

FCC - TEST REPORT

Report Number : **68.950.20.0125.01** Date of Issue: **June 29, 2020**

Model : MM3SB3350N3

Product Type : Bluetooth&Wi-Fi dual band Communication Module

Applicant : GD Midea Air-Conditioning Equipment Co., Ltd.

Address : Lingang Road Beijiao, Shunde FOSHAN China

Manufacturer&Factory : GD Midea Air-Conditioning Equipment Co., Ltd.

Address : Lingang Road Beijiao, Shunde FOSHAN China

Test Result : Positive Negative

Total pages including Appendices : **64**

TÜV SÜD Certification and Testing (China) Co., Ltd. Shenzhen Branch is a subcontractor to TÜV SÜD Product Service GmbH according to the principles outlined in ISO 17025.

TÜV SÜD Certification and Testing (China) Co., Ltd. Shenzhen Branch reports apply only to the specific samples tested under stated test conditions. Construction of the actual test samples has been documented. It is the manufacturer's responsibility to assure that additional production units of this model are manufactured with identical electrical and mechanical components. The manufacturer/importer is responsible to the Competent Authorities in Europe for any modifications made to the production units which result in non-compliance to the relevant regulations. TÜV SÜD Certification and Testing (China) Co., Ltd. Shenzhen Branch shall have no liability for any deductions, inferences or generalizations drawn by the client or others from TÜV SÜD Certification and Testing (China) Co., Ltd. Shenzhen Branch issued reports.

This report is the confidential property of the client. As a mutual protection to our clients, the public and ourselves, extracts from the test report shall not be reproduced except in full without our written approval

1 Table of Contents

1	Table of Contents	2
2	Details about the Test Laboratory.....	3
3	Description of the Equipment Under Test.....	4
4	Summary of Test Standards	5
5	Summary of Test Results	6
6	General Remarks	7
7	Test Setups.....	8
8	Systems test configuration	9
9	Technical Requirement.....	10
9.1	Conducted Emission.....	10
9.2	Conducted peak output power.....	13
9.3	6dB bandwidth and 99% Occupied Bandwidth.....	15
9.4	Power spectral density.....	24
9.5	Spurious RF conducted emissions.....	29
9.6	Band edge testing	43
9.7	Spurious radiated emissions for transmitter	47
10	Test Equipment List.....	63
11	System Measurement Uncertainty.....	64

2 Details about the Test Laboratory

Details about the Test Laboratory

Test Site 1

Company name: TÜV SÜD Certification and Testing (China) Co., Ltd. Shenzhen Branch
Building 12&13, Ziheng Wisdomland Business Park,
Nantou Checkpoint Road 2, Nanshan District,
Shenzhen City, 518052,
P. R. China

FCC Registration No.: 514049

Telephone: 86 755 8828 6998
Fax: 86 755 8828 5299

3 Description of the Equipment Under Test

Product:	Bluetooth &Wi-Fi dual band Communication Module
Model no.:	MM3SB3350N3
Brand Name	Midea
FCC ID:	2ADQO3SB3350N3
Options and accessories:	NIL
Rating:	DC 3.3V
RF Transmission Frequency:	2412-2462MHz
No. of Operated Channel:	11
Modulation:	DSSS, OFDM
Antenna Type:	PIFA antenna
Antenna Gain:	2dBi
Description of the EUT:	The Equipment Under Test (EUT) is a Communication Module which support 2.4G Wi-Fi, 5G Wi-Fi and BLE function. The 2.4G Wi-Fi and BLE operated at 2400MHz to 2483.5MHz, The 5G Wi-Fi operation 5150MHz to 5250MHz, 5250MHz to 5350MHz, 5470MHz to 5725MHz, and 5725MHz to 5825Mhz.

4 Summary of Test Standards

Test Standards	
FCC Part 15 Subpart C 10-1-2019 Edition	PART 15 - RADIO FREQUENCY DEVICES Subpart C - Intentional Radiators

All the test methods were according to KDB 558074 D01 DTS Measurement Guidance v05r02 DTS Measurement Guidance and ANSI C63.10 (2013).

5 Summary of Test Results

Technical Requirements					
FCC Part 15 Subpart C					
Test Condition		Test Site	Test Result		
			Pass	Fail	N/A
§15.207	Conducted emission AC power port	Site 1	<input checked="" type="checkbox"/>	<input type="checkbox"/>	<input type="checkbox"/>
§15.247 (b) (1)	Conducted peak output power	Site 1	<input checked="" type="checkbox"/>	<input type="checkbox"/>	<input type="checkbox"/>
§15.247(a)(1)	20dB bandwidth	---	<input type="checkbox"/>	<input type="checkbox"/>	<input checked="" type="checkbox"/>
§15.247(a)(1)	Carrier frequency separation	---	<input type="checkbox"/>	<input type="checkbox"/>	<input checked="" type="checkbox"/>
§15.247(a)(1)(iii)	Number of hopping frequencies	---	<input type="checkbox"/>	<input type="checkbox"/>	<input checked="" type="checkbox"/>
§15.247(a)(1)(iii)	Dwell Time	---	<input type="checkbox"/>	<input type="checkbox"/>	<input checked="" type="checkbox"/>
§15.247(a)(2)	6dB bandwidth and 99% Occupied Bandwidth	Site 1	<input checked="" type="checkbox"/>	<input type="checkbox"/>	<input type="checkbox"/>
§15.247(e)	Power spectral density	Site 1	<input checked="" type="checkbox"/>	<input type="checkbox"/>	<input type="checkbox"/>
§15.247(d)	Spurious RF conducted emissions	Site 1	<input checked="" type="checkbox"/>	<input type="checkbox"/>	<input type="checkbox"/>
§15.247(d)	Band edge	Site 1	<input checked="" type="checkbox"/>	<input type="checkbox"/>	<input type="checkbox"/>
§15.247(d) & §15.209	Spurious radiated emissions for transmitter	Site 1	<input checked="" type="checkbox"/>	<input type="checkbox"/>	<input type="checkbox"/>
§15.203	Antenna requirement	See note 2	<input checked="" type="checkbox"/>	<input type="checkbox"/>	<input type="checkbox"/>

Note 1: N/A=Not Applicable.

Note 2: The EUT uses an internal antenna, which gain is 2dBi. In accordance to §15.203, It is considered sufficiently to comply with the provisions of this section.

6 General Remarks

Remarks

This submittal(s) (test report) is intended for FCC ID: 2ADQO3SB3350N3, complies with Section 15.209, 15.247 of the FCC Part 15, Subpart C rules.

The Equipment Under Test (EUT) is a Communication Module, it has BLE, 2.4G Wi-Fi and 5G Wi-Fi Wireless function, the Wi-Fi have 2 working mode with master mode and slave mode.

The TX and RX range is 2402MHz-2480MHz for BLE, 2412MHz – 2462MHz for 2.4GHzWi-Fi, 5180MHz – 5320MHz, 5500MHz – 5700MHz, 5745MHz – 5825MHz for 5GHzWIFI.

This report is for the 2.4GHz Wi-Fi.

SUMMARY:

All tests according to the regulations cited on page 5 were

- Performed

- **Not** Performed

The Equipment Under Test

- **Fulfills** the general approval requirements.

- **Does not** fulfill the general approval requirements.

Sample Received Date: March 24, 2020

Testing Start Date: March 25, 2020

Testing End Date: June 19, 2020

TÜV SÜD Certification and Testing (China) Co., Ltd. Shenzhen Branch

Reviewed by:

Prepared by:

Tested by:

John Zhi
Section Manager

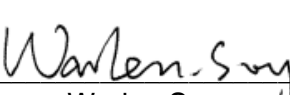

Warlen Song
Project Engineer

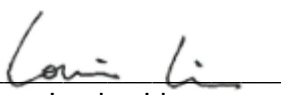

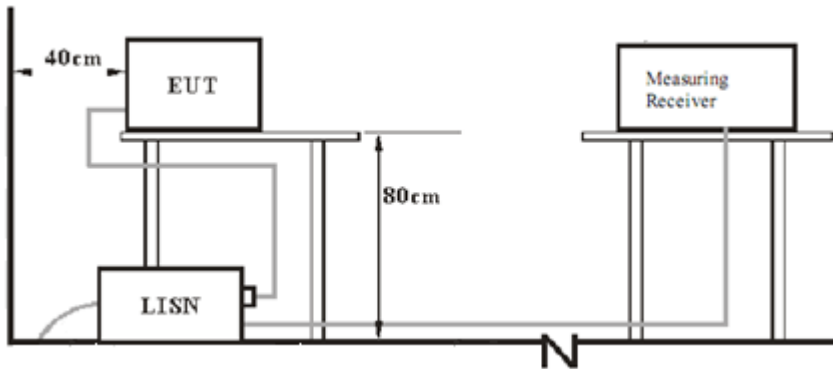

Louise Liu
Test Engineer

7 Test Setups

7.1 AC Power Line Conducted Emission test setups

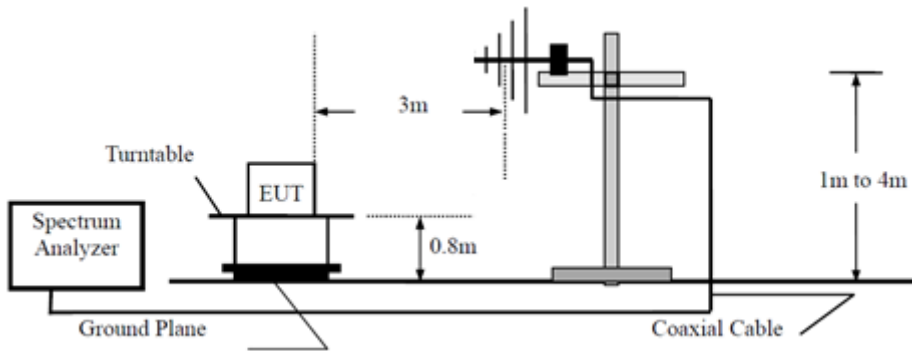

7.2 Radiated test setups Below 1GHz



Above 1GHz

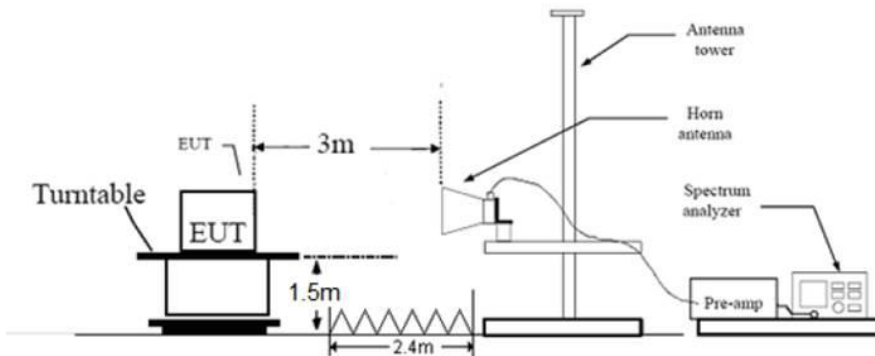

7.3 Conducted RF test setups

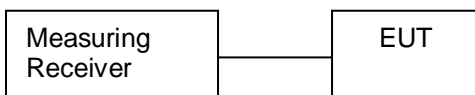

8 Systems test configuration

Auxiliary Equipment Used during Test:

DESCRIPTION	MANUFACTURER	MODEL NO.(SHIELD)	S/N(LENGTH)
Phone	ZTE	--	--
Notebook	Lenovo	X220	

Test software: RF test tool

Test Channel:	L	M	H
11B	2412	2437	2462
11G	2412	2437	2462
11N_20	2412	2437	2462
11N_40	2422	2437	2452

9 Technical Requirement

9.1 Conducted Emission

Test Method

1. The EUT was placed on a table, which is 0.8m above ground plane
2. The power line of the EUT is connected to the AC mains through a Artificial Mains Network (A.M.N.).
3. Maximum procedure was performed to ensure EUT compliance
4. A EMI test receiver is used to test the emissions from both sides of AC line

Limit

According to §15.207, conducted emissions limit as below:

Frequency MHz	QP Limit dB μ V	AV Limit dB μ V
0.150-0.500	66-56*	56-46*
0.500-5	56	46
5-30	60	50

Remark: "*" Decreasing linearly with logarithm of the frequency

Conducted Emission

Product Type : Bluetooth & Wi-Fi dual band Communication Module
 M/N : MM3SB3350N3
 Operating Condition : Wi-Fi Linking
 Test Specification : Power Line, Live
 Comment : AC 120V/60Hz (the power by notebook)

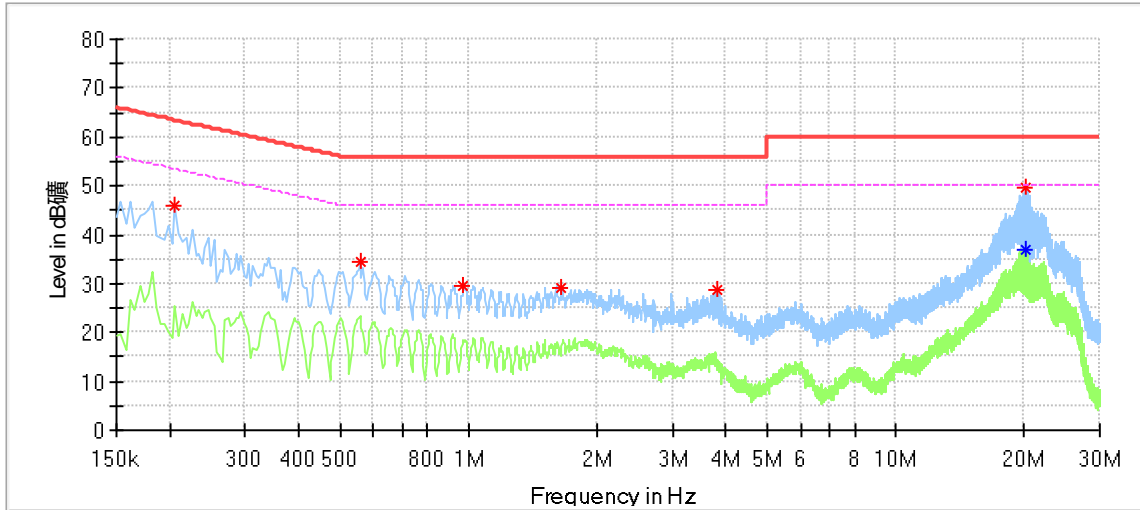

Critical_Freqs

Frequency (MHz)	MaxPeak (dBμV)	Average (dBμV)	Limit (dBμV)	Margin (dB)	Line	Corr. (dB)
0.206000	45.83	---	63.37	17.53	L1	9.5
0.558000	34.28	---	56.00	21.72	L1	9.6
0.974000	29.61	---	56.00	26.39	L1	9.6
1.650000	29.17	---	56.00	26.83	L1	9.6
3.814000	28.61	---	56.00	27.39	L1	9.6
20.154000	49.75	---	60.00	10.25	L1	9.8
20.182000	---	37.11	50.00	12.89	L1	9.8

Remark :

Level=Reading Level + Correction Factor

Correction Factor=Cable Loss + LISN Factor

(The Reading Level is recorded by software which is not shown in the sheet)

Conducted Emission

Product Type : Bluetooth & Wi-Fi dual band Communication Module
 M/N : MM3SB3350N3
 Operating Condition : Wi-Fi Linking
 Test Specification : Power Line, Live
 Comment : AC 120V/60Hz (the power by notebook)

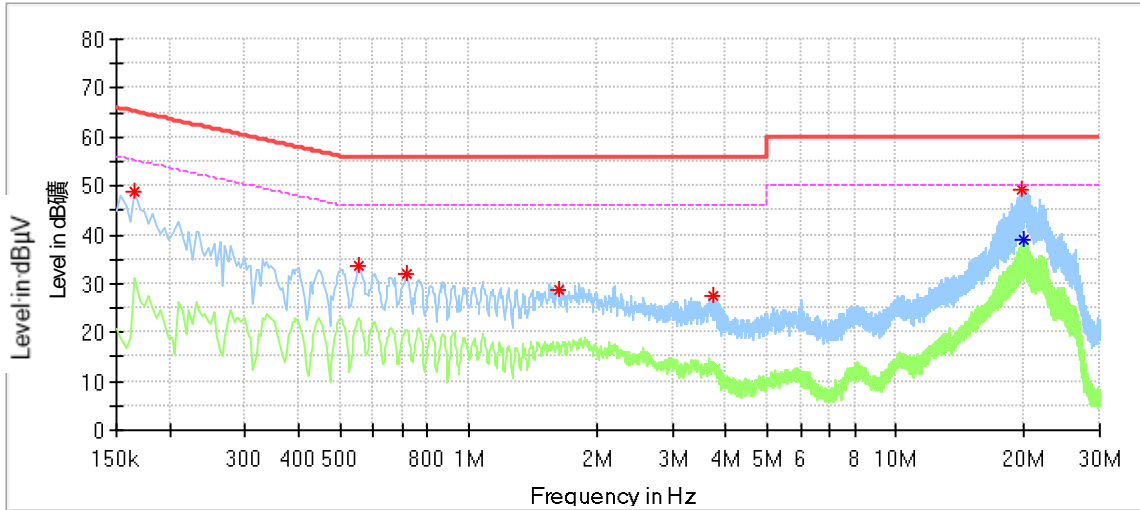

Critical_Freqs

Frequency (MHz)	MaxPeak (dBµV)	Average (dBµV)	Limit (dBµV)	Margin (dB)	Line	Corr. (dB)
0.166000	48.97	---	65.16	16.19	N	9.5
0.554000	33.65	---	56.00	22.35	N	9.6
0.714000	31.98	---	56.00	24.02	N	9.6
1.622000	28.71	---	56.00	27.29	N	9.6
3.726000	27.46	---	56.00	28.54	N	9.6
19.762000	49.08	---	60.00	10.92	N	9.9
19.966000	---	38.94	50.00	11.06	N	9.9

Remark :

Level=Reading Level + Correction Factor

Correction Factor=Cable Loss + LISN Factor

(The Reading Level is recorded by software which is not shown in the sheet)

9.2 Conducted peak output power

Test Method

1. Connect the power meter to the EUT
 - a) The EUT is configured to transmit continuously, or to transmit with a constant duty factor.
 - b) At all times the EUT is transmitting at its maximum power control level.
 - c) The integration period of the power meter exceeds the repetition period of the transmitted signal by at least a factor of five.
2. Measure the average power of the transmitter. This measurement is an average over both the on and off periods of the transmitter.
3. Adjust the measurement in dBm by adding $10\log(1/x)$, where x is the duty cycle to the measurement result.

Limits

According to §15.247 (b) (1), conducted peak output power limit as below:

Frequency Range MHz	Limit W	Limit dBm
2400-2483.5	≤1	≤30

Test result as below table

802.11b modulation Test Result

Frequency (MHz)	Conducted Peak Output Power (dBm)	Limit (dBm)	Result
Low channel 2412MHz	14.3	30	Pass
Middle channel 2437MHz	14.3	30	Pass
High channel 2462MHz	14.3	30	Pass

802.11g modulation Test Result

Frequency (MHz)	Conducted Peak Output Power (dBm)	Limit (dBm)	Result
Low channel 2412MHz	13.8	30	Pass
Middle channel 2437MHz	13.9	30	Pass
High channel 2462MHz	13.8	30	Pass

802.11n20 modulation Test Result

Frequency (MHz)	Conducted Peak Output Power (dBm)	Limit (dBm)	Result
Low channel 2412MHz	13.6	30	Pass
Middle channel 2437MHz	13.6	30	Pass
High channel 2462MHz	13.6	30	Pass

802.11n40 modulation Test Result

Frequency (MHz)	Conducted Peak Output Power (dBm)	Limit (dBm)	Result
Low channel 2422MHz	13.7	30	Pass
Middle channel 2437MHz	13.8	30	Pass
High channel 2452MHz	14.0	30	Pass

9.3 6dB bandwidth and 99% Occupied Bandwidth

Test Method for 6 dB Bandwidth

1. Use the following spectrum analyzer settings:
RBW=100K, VBW≥3RBW, Sweep = auto, Detector function = peak, Trace = max hold
2. Use the automatic bandwidth measurement capability of an instrument, may be employed using the X dB bandwidth mode with X set to 6 dB, care shall be taken so that the bandwidth measurement is not influenced by any intermediate power nulls in the fundamental emission that might be ≥ 6 dB.
3. Allow the trace to stabilize, record the X dB Bandwidth value.

Limit

Limit [kHz]

≥500

Test result

802.11b modulation Test Result

Frequency (MHz)	6dB bandwidth (MHz)	99% bandwidth (MHz)	Limit (MHz)	Result
Low channel 2412MHz	9.840	14.266	/	Pass
Middle channel 2437MHz	10.120	14.266	/	Pass
High channel 2462MHz	10.120	14.266	/	Pass

802.11g modulation Test Result

Frequency (MHz)	6dB bandwidth (MHz)	99% bandwidth (MHz)	Limit (MHz)	Result
Low channel 2412MHz	14.520	17.063	/	Pass
Middle channel 2437MHz	16.400	17.063	/	Pass
High channel 2462MHz	12.640	17.063	/	Pass

802.11n-HT20 modulation Test Result

Frequency (MHz)	6dB bandwidth (MHz)	99% bandwidth (MHz)	Limit (MHz)	Result
Low channel 2412MHz	15.240	17.862	/	Pass
Middle channel 2437MHz	14.760	17.902	/	Pass
High channel 2462MHz	15.160	17.902	/	Pass

802.11n-HT40 modulation Test Result

Frequency (MHz)	6dB bandwidth (MHz)	99% bandwidth (MHz)	Limit (MHz)	Result
Low channel 2422MHz	35.200	36.124	/	Pass
Middle channel 2437MHz	35.200	36.124	/	Pass
High channel 2452MHz	35.200	36.124	/	Pass

6 dB Bandwidth

11B_Ant1_2412

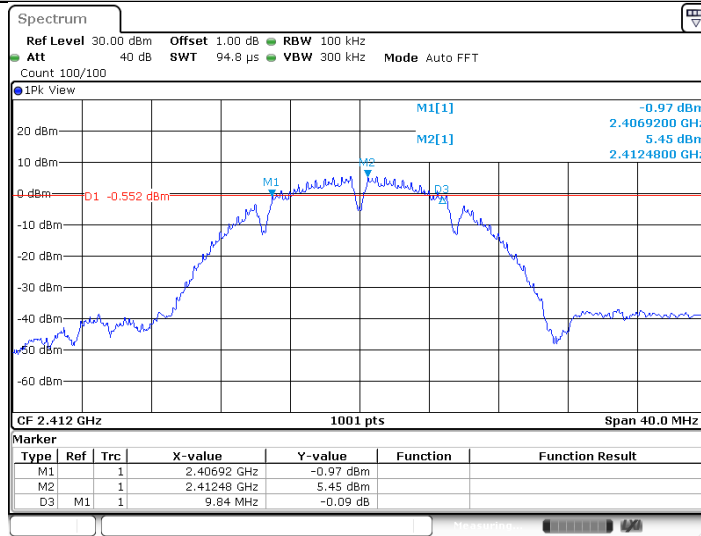

Date: 5 APR 2020 14:37:36

11B_Ant1_2437

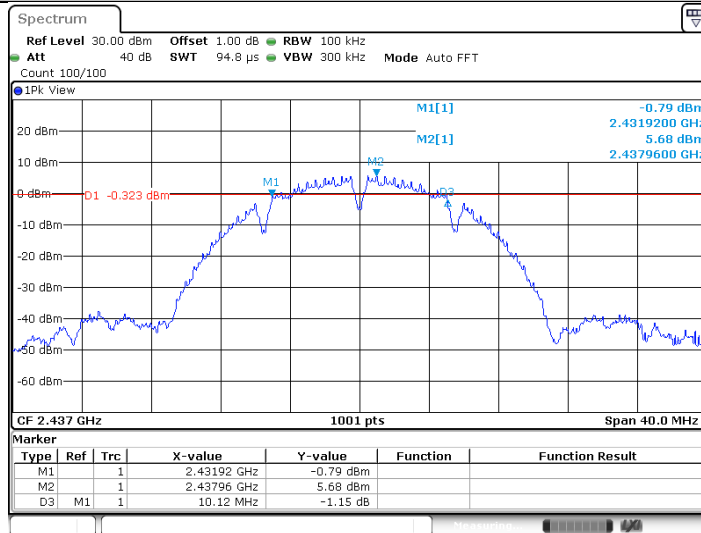

Date: 5 APR 2020 14:41:05

11B_Ant1_2462

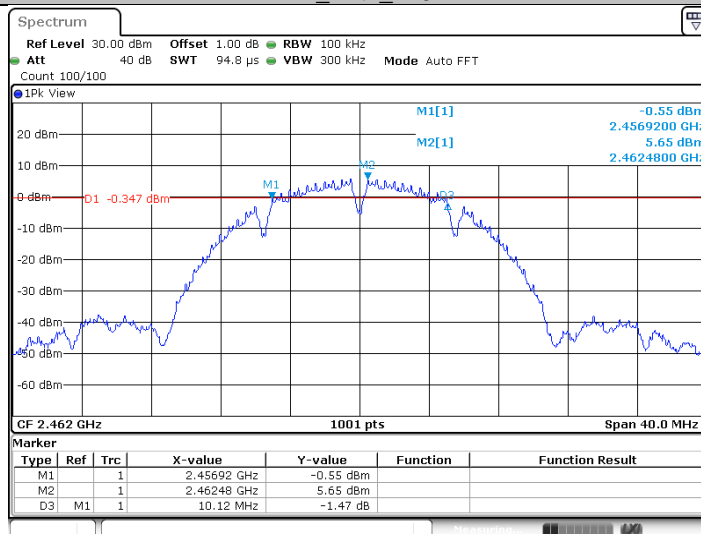

Date: 5 APR 2020 14:42:32

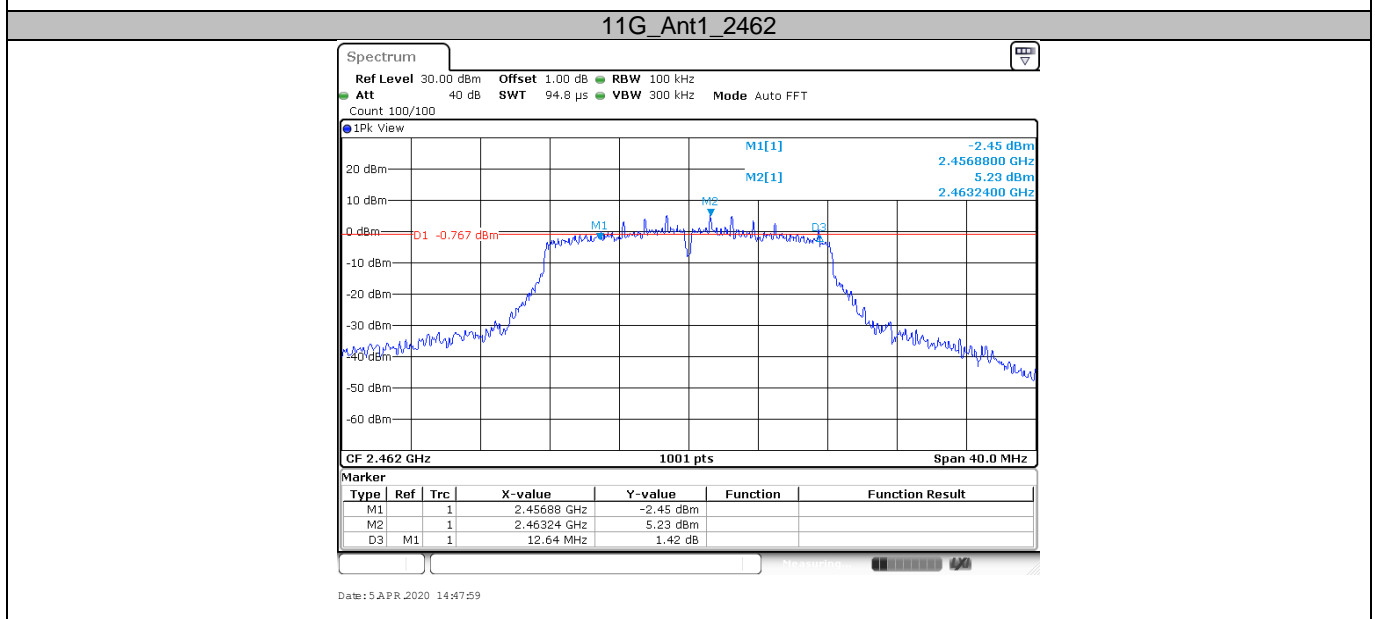
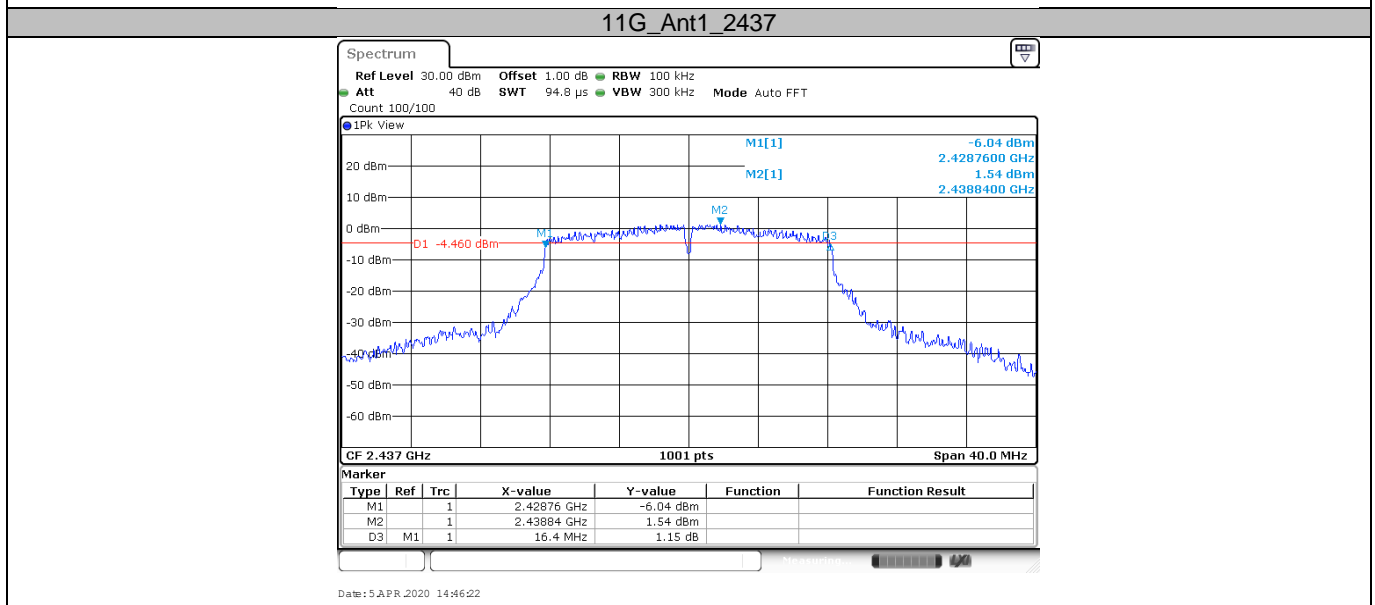
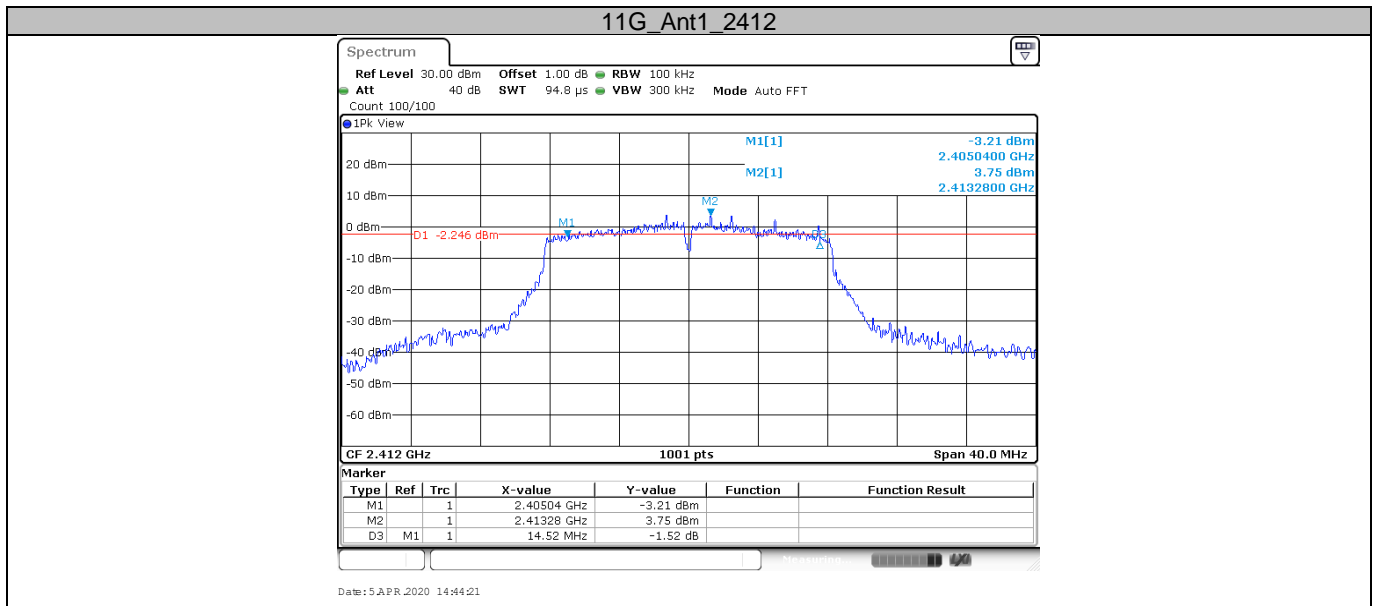

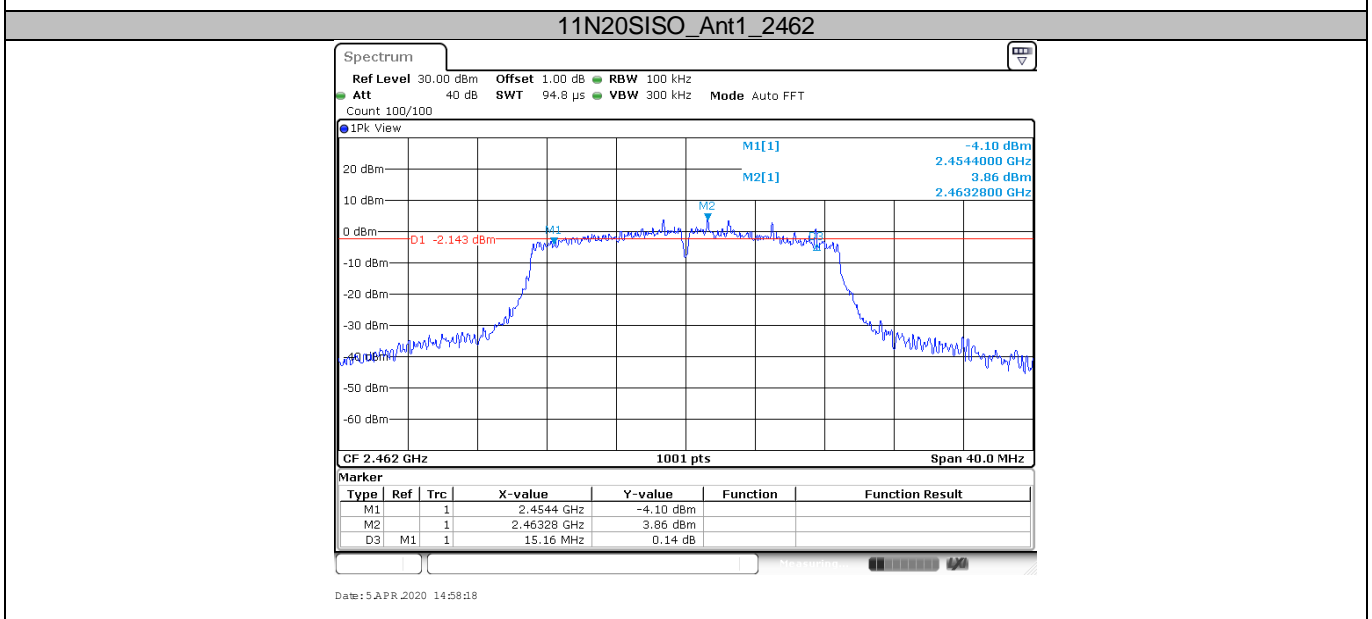
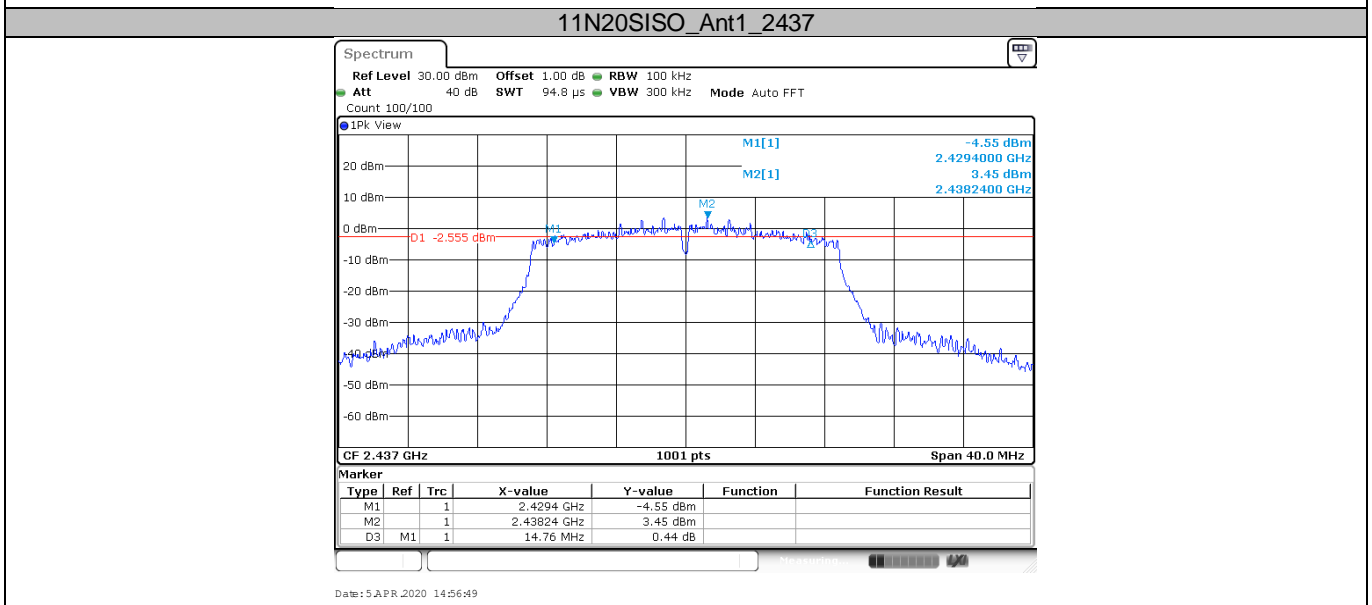
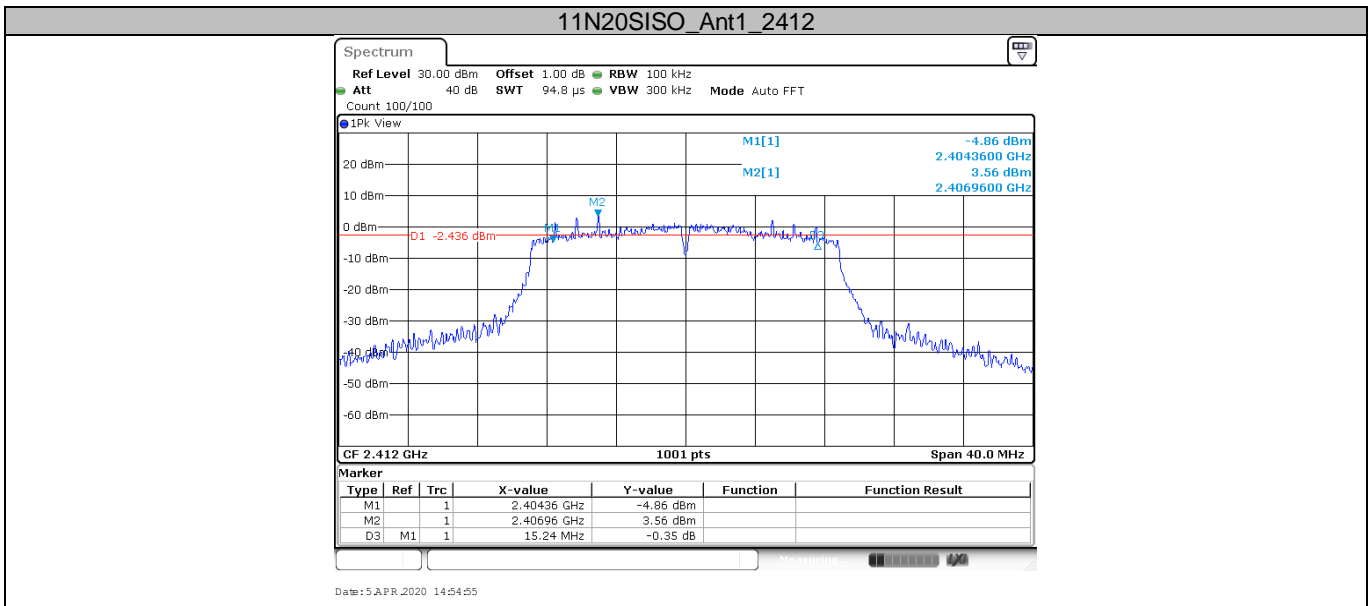

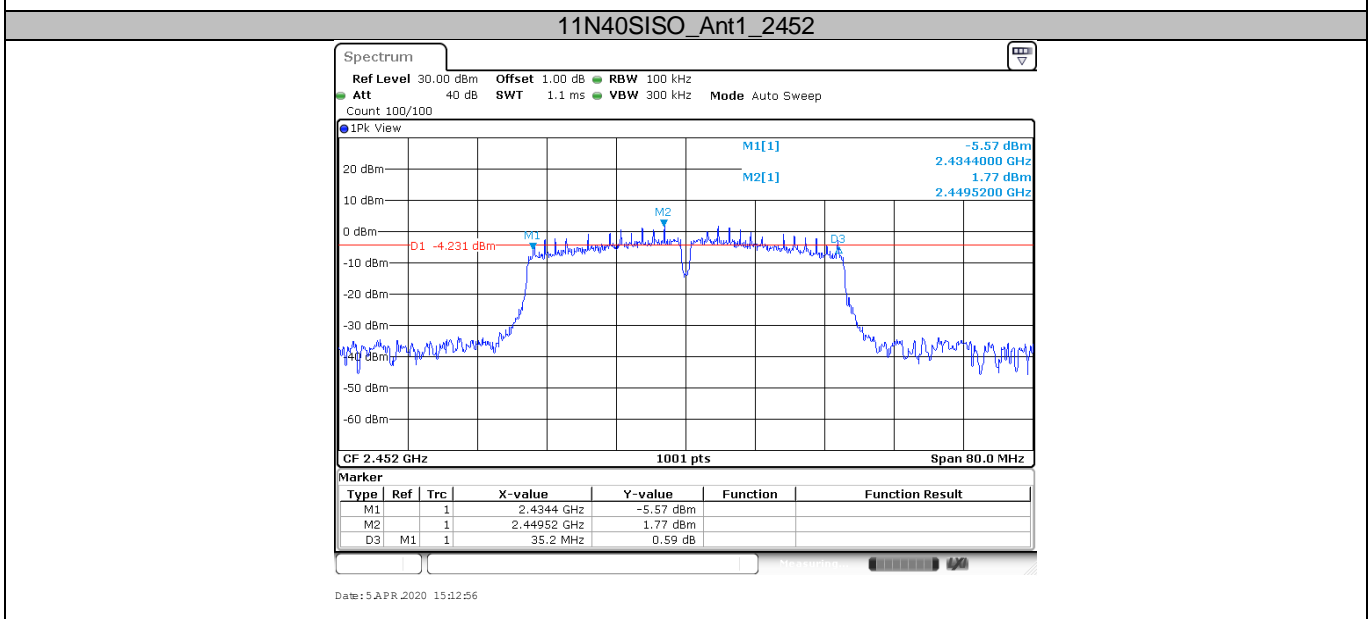
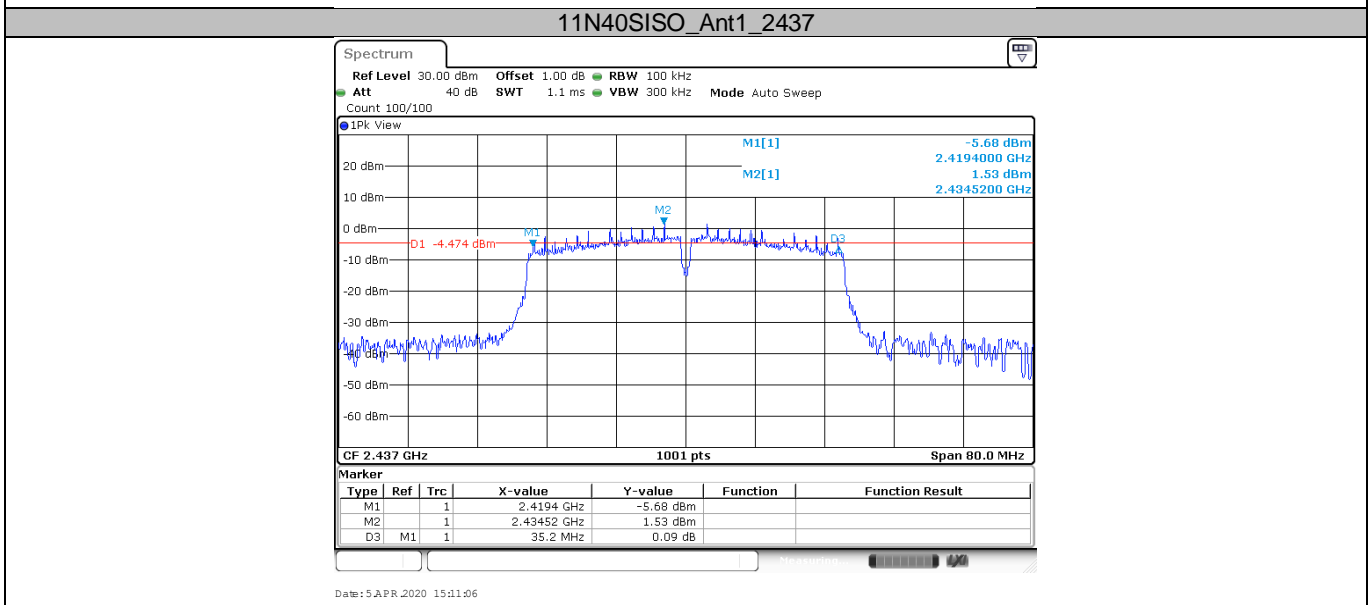
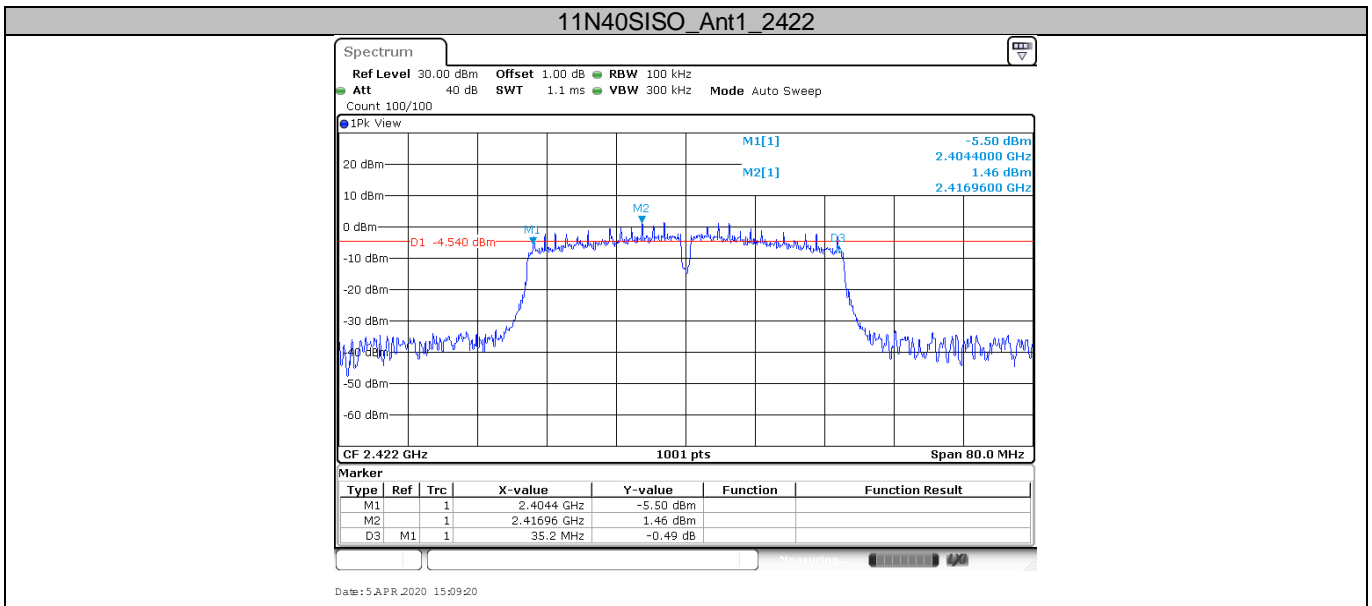

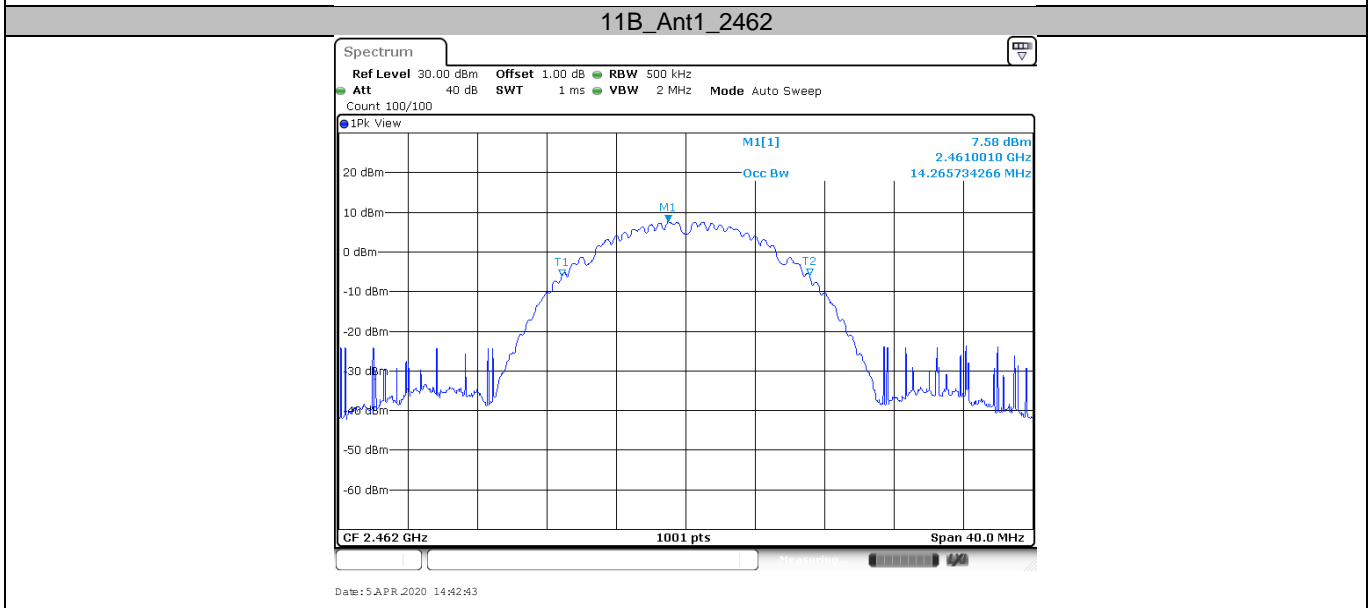
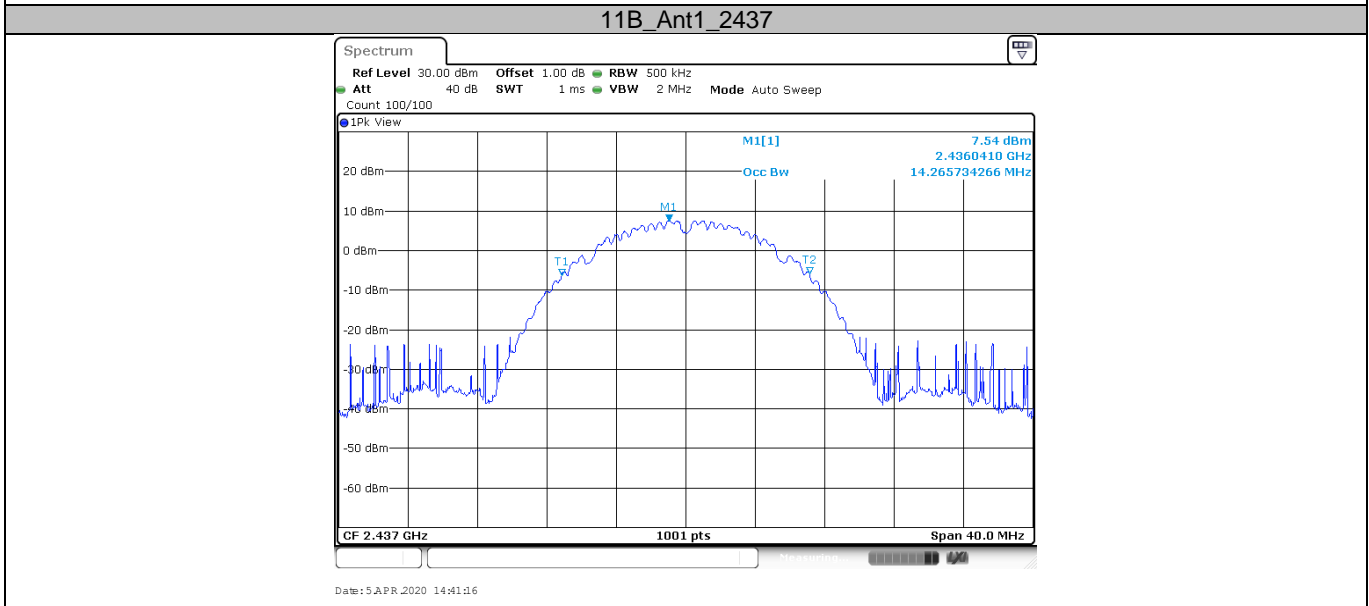
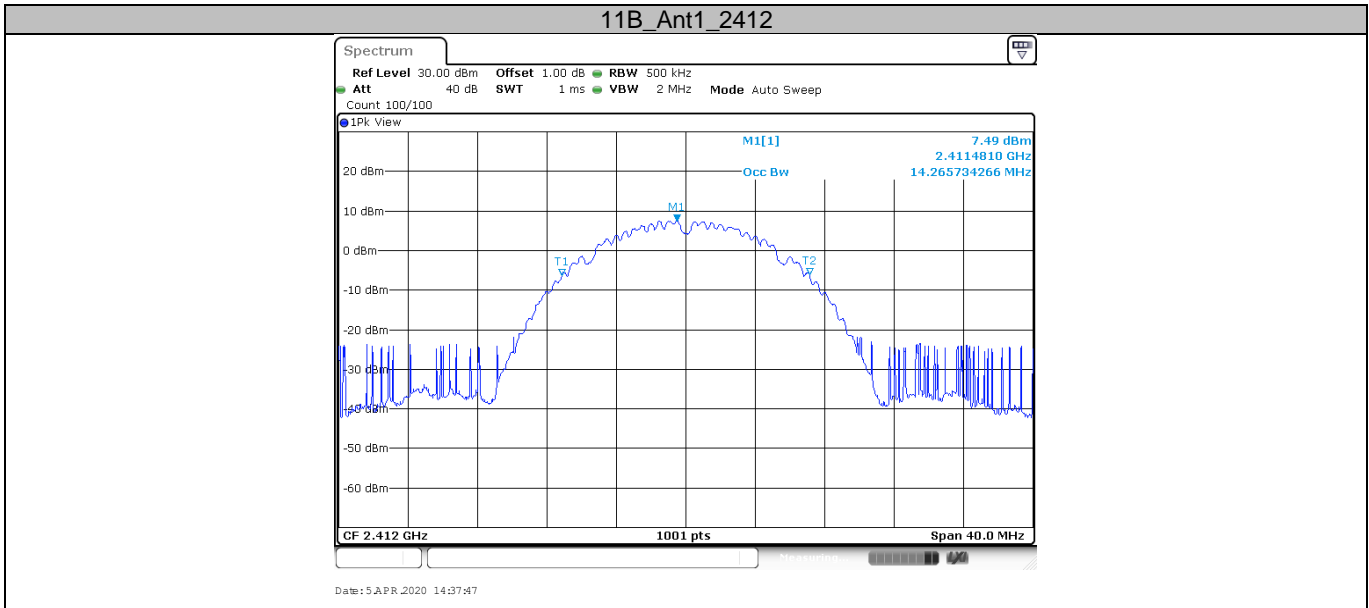

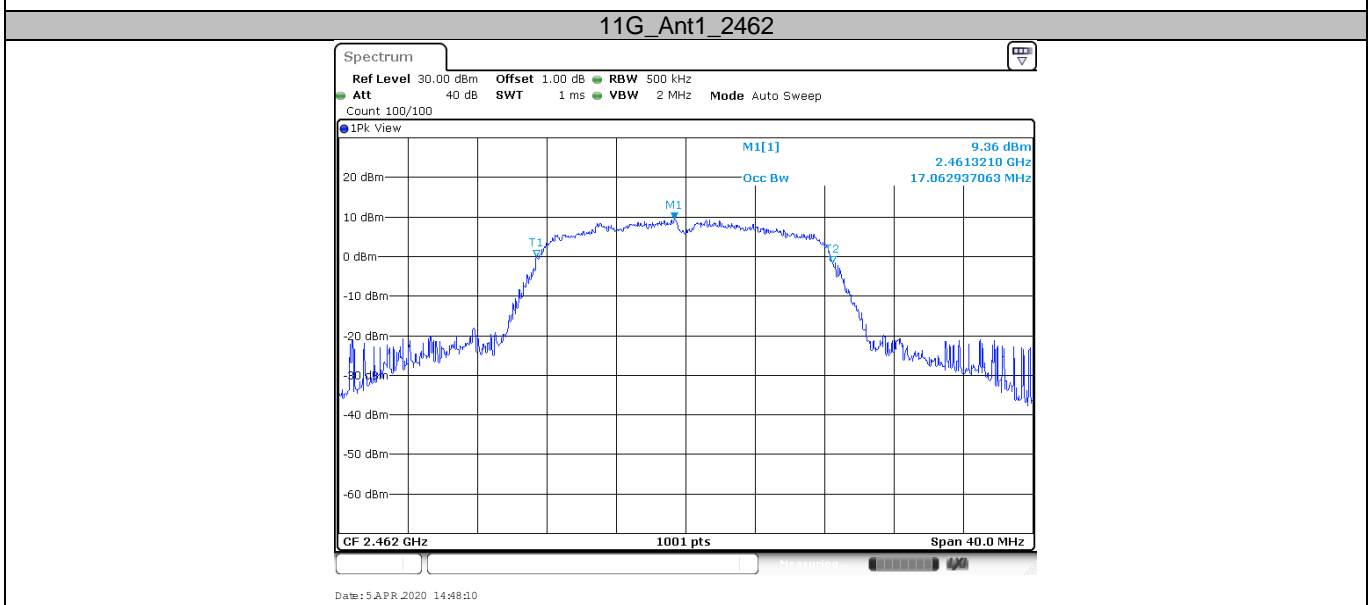
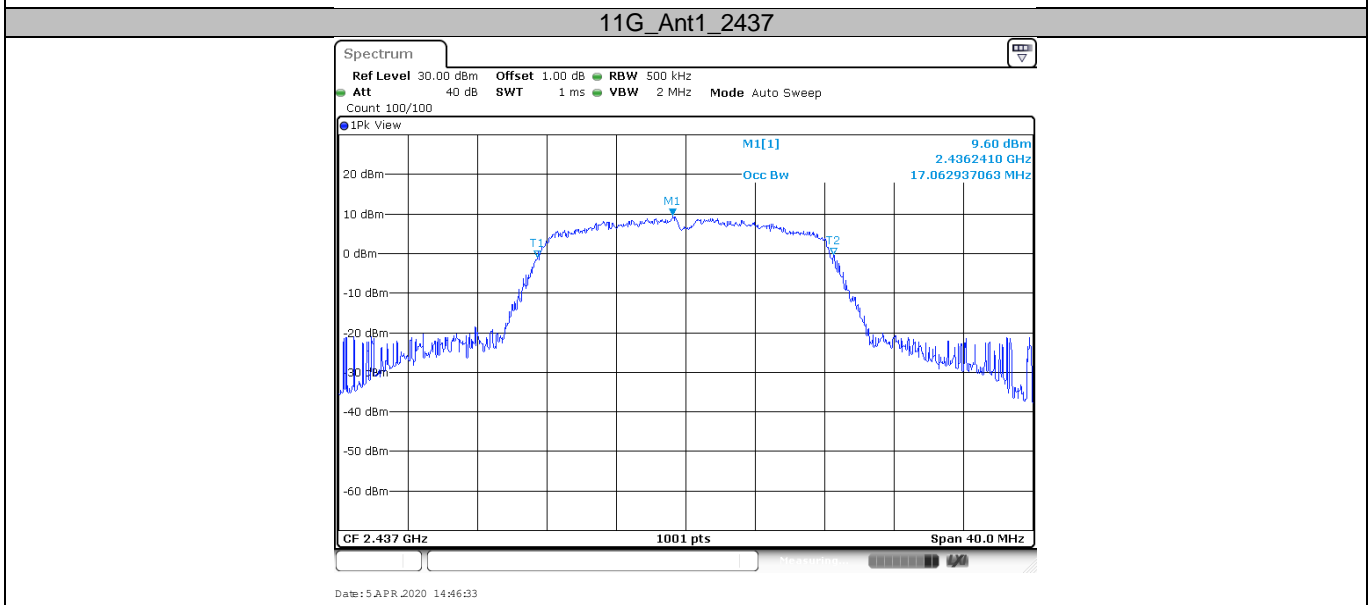
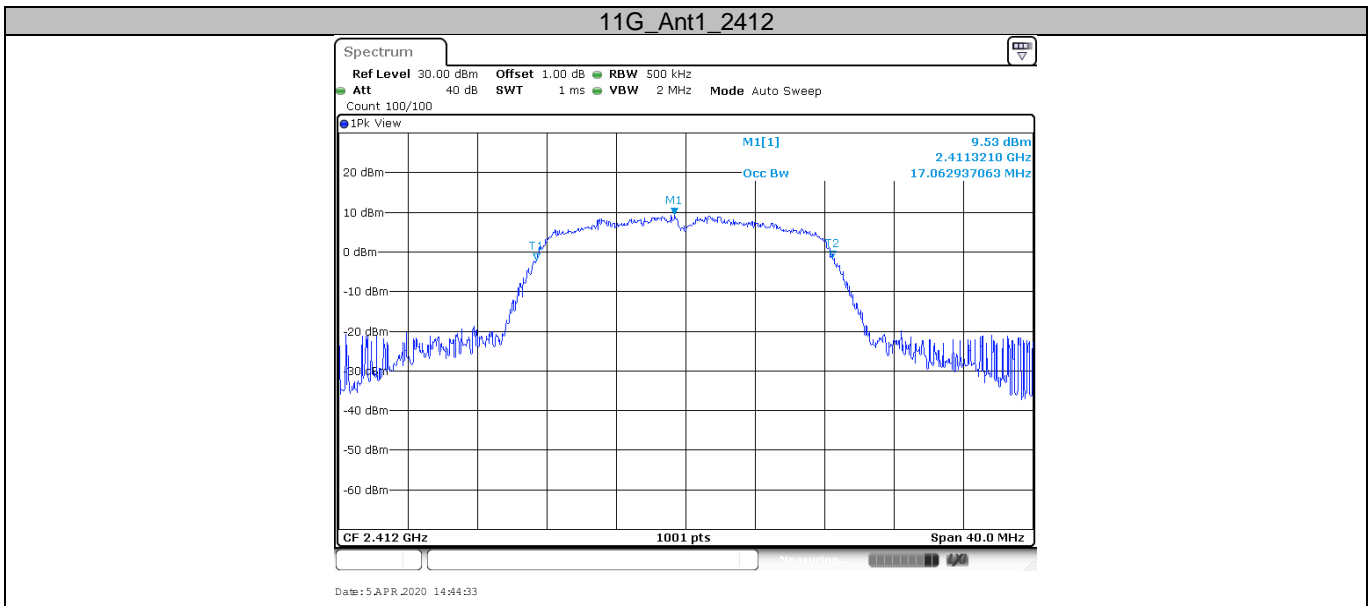

11N20SISO_Ant1_2412

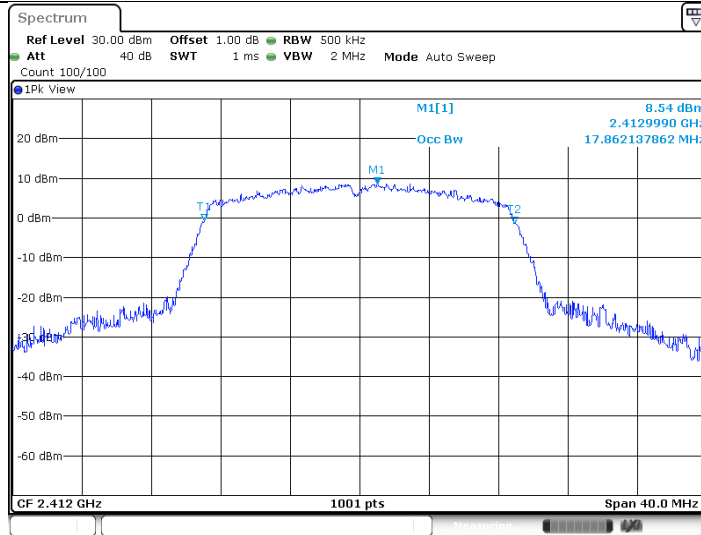

Date: 5 APR 2020 14:55:07

11N20SISO_Ant1_2437

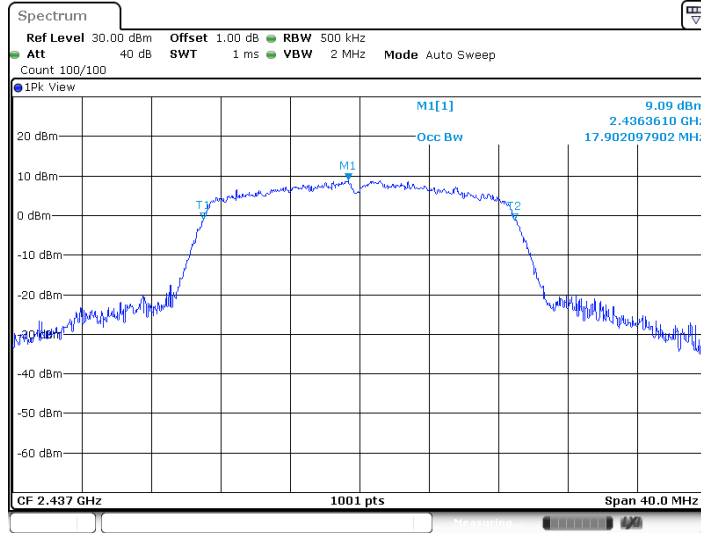

Date: 5 APR 2020 14:57:00

11N20SISO_Ant1_2462

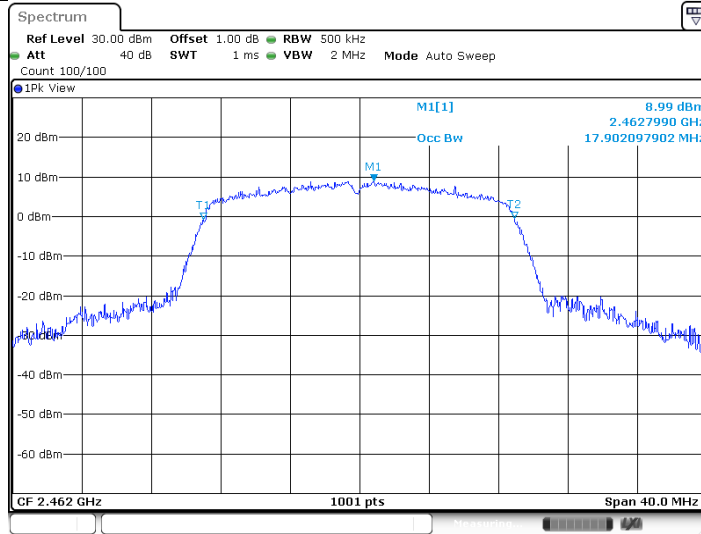

Date: 5 APR 2020 14:58:29

11N40SISO_Ant1_2422

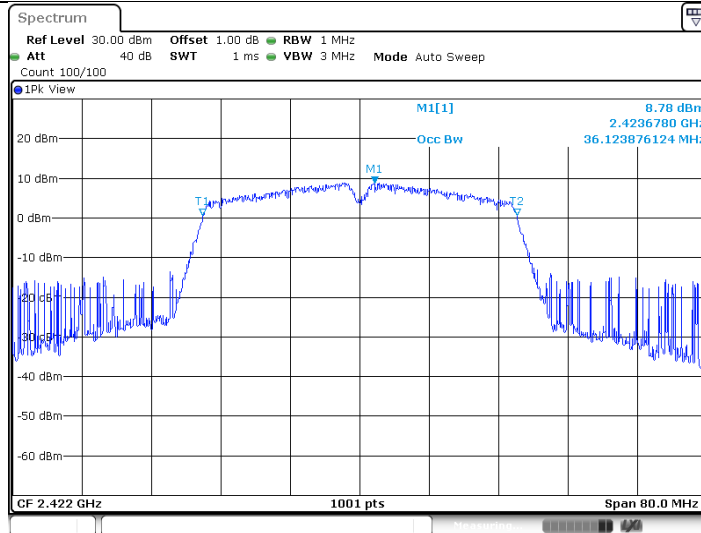

Date: 5 APR 2020 15:09:31

11N40SISO_Ant1_2437

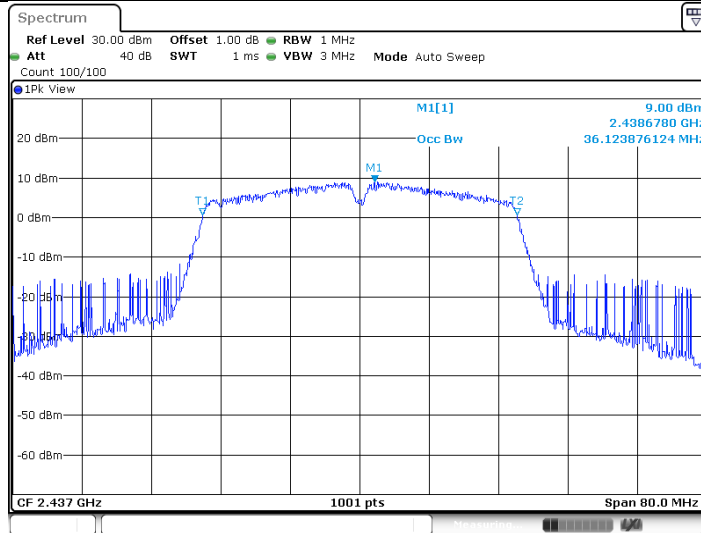

Date: 5 APR 2020 15:11:17

11N40SISO_Ant1_2452

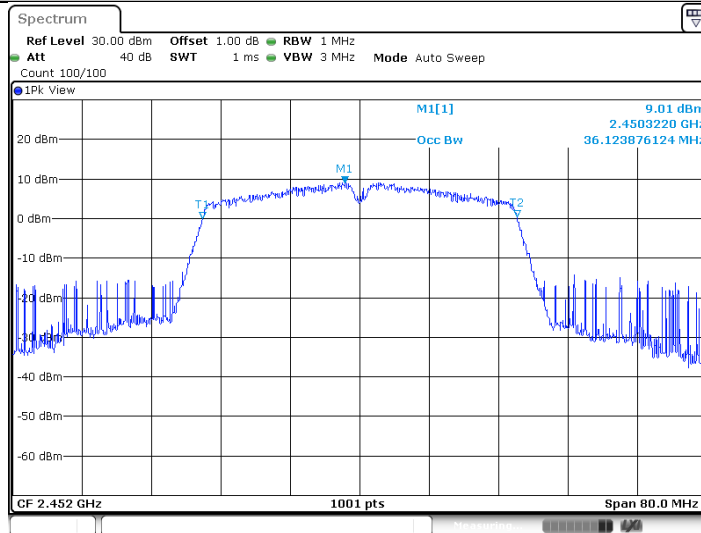

Date: 5 APR 2020 15:13:08

9.4 Power spectral density

Test Method

This procedure shall be used if maximum peak conducted output power was used to demonstrate compliance:

1. Set analyzer center frequency to DTS channel center frequency. RBW=3kHz, VBW≥3RBW, Span=1.5 times DTS bandwidth, Detector=Peak, Sweep=auto, Trace= max hold.
2. Allow trace to fully stabilize, use the peak marker function to determine the maximum amplitude level within the RBW.
3. Repeat above procedures until other frequencies measured were completed.

Limit

Limit [dBm dBm/3KHz]

≤8

802.11b modulation Test Result

Frequency (MHz)	Power spectral density (dBm dBm/3KHz)	Limit (dBm)	Result
Low channel 2412MHz	4.50	8	Pass
Middle channel 2437MHz	4.82	8	Pass
High channel 2462MHz	2.63	8	Pass

802.11g modulation Test Result

Frequency (MHz)	Power spectral density (dBm dBm/3KHz)	Limit (dBm)	Result
Low channel 2412MHz	-12.87	8	Pass
Middle channel 2437MHz	-12.73	8	Pass
High channel 2462MHz	-13.29	8	Pass

802.11n-HT20 modulation Test Result

Frequency (MHz)	Power spectral density (dBm dBm/3KHz)	Limit (dBm)	Result
Low channel 2412MHz	-13.25	8	Pass
Middle channel 2437MHz	-14.1	8	Pass
High channel 2462MHz	-14.85	8	Pass

802.11n-HT40 modulation Test Result

Frequency (MHz)	Power spectral density (dBm dBm/3KHz)	Limit (dBm)	Result
Low channel 2422MHz	-14.19	8	Pass
Middle channel 2437MHz	-15.04	8	Pass
High channel 2452MHz	-14.22	8	Pass

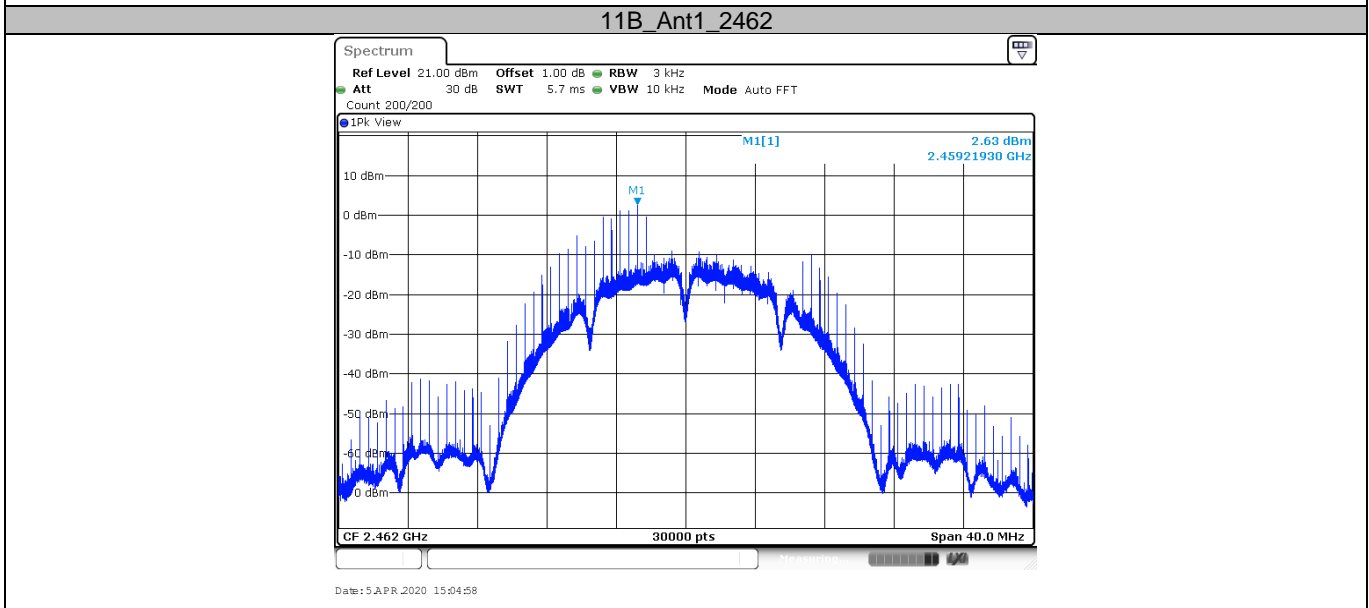
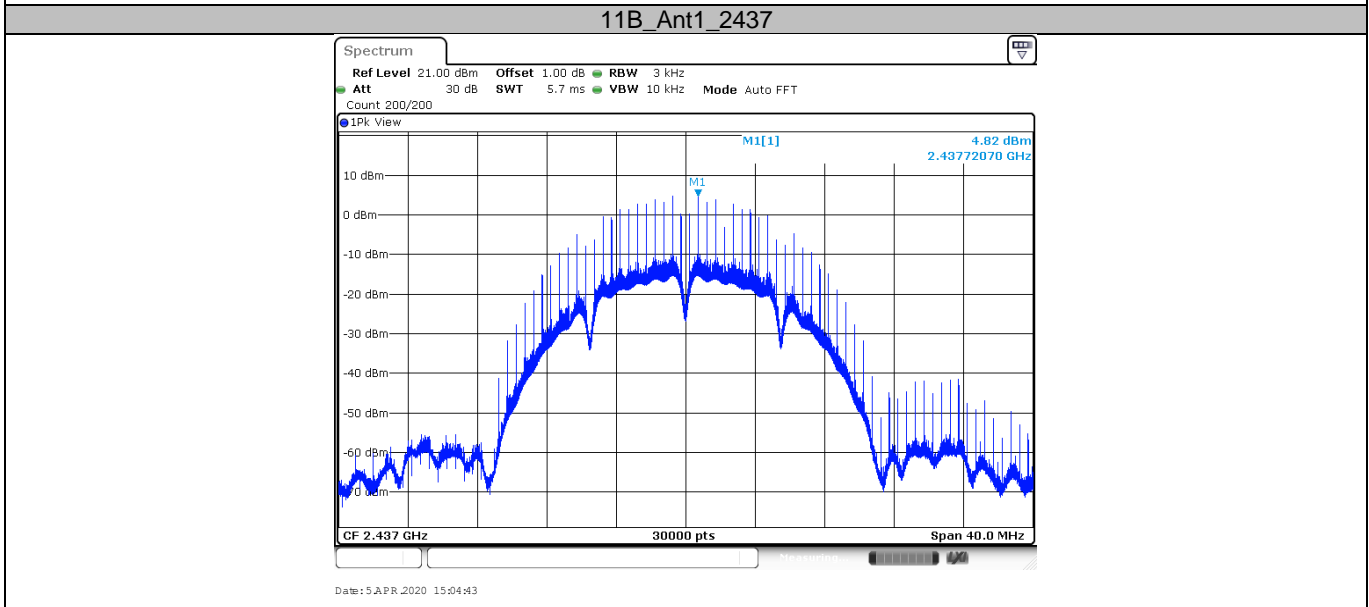
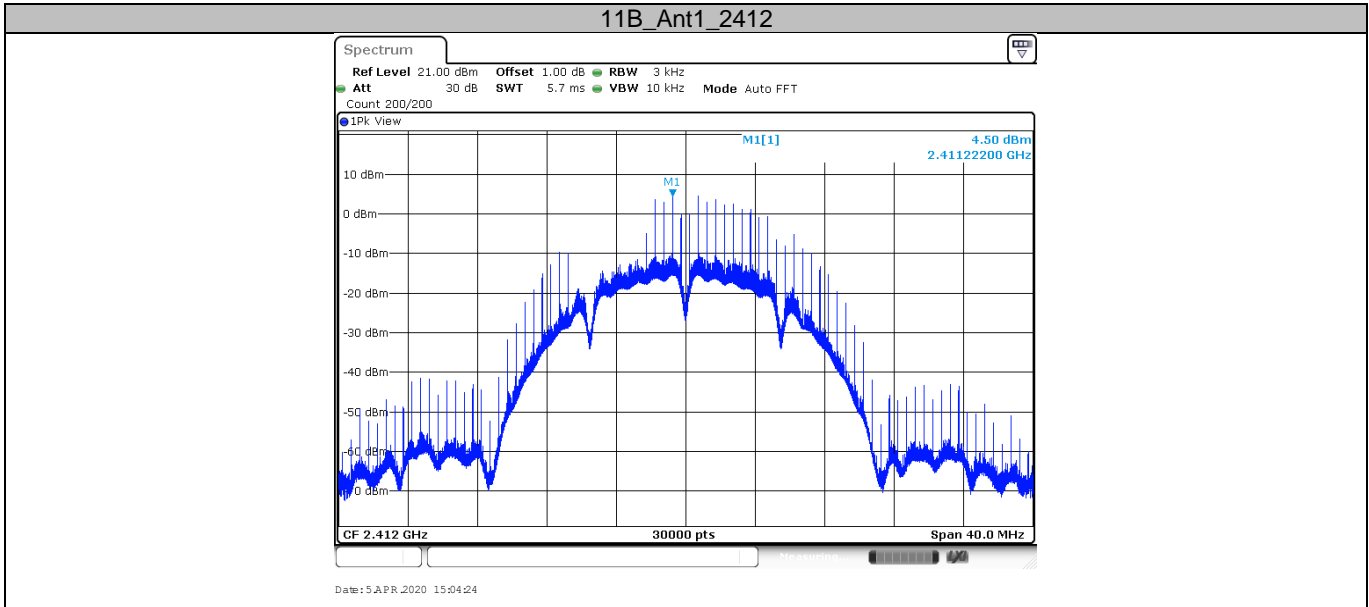

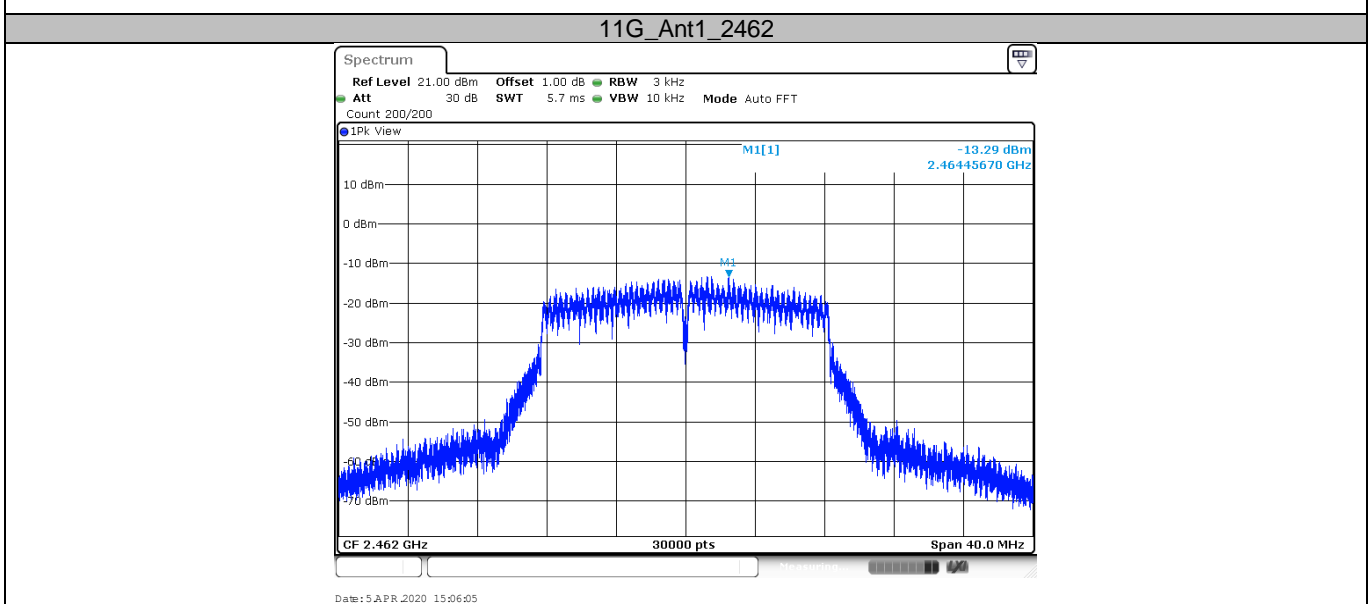
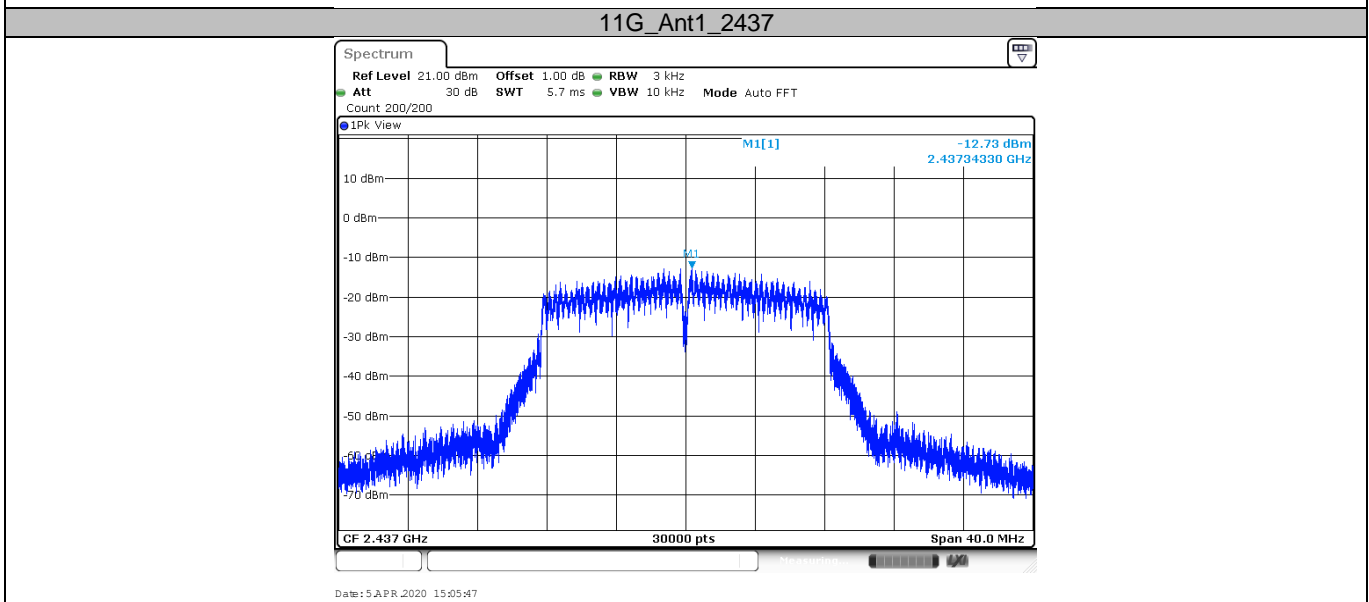
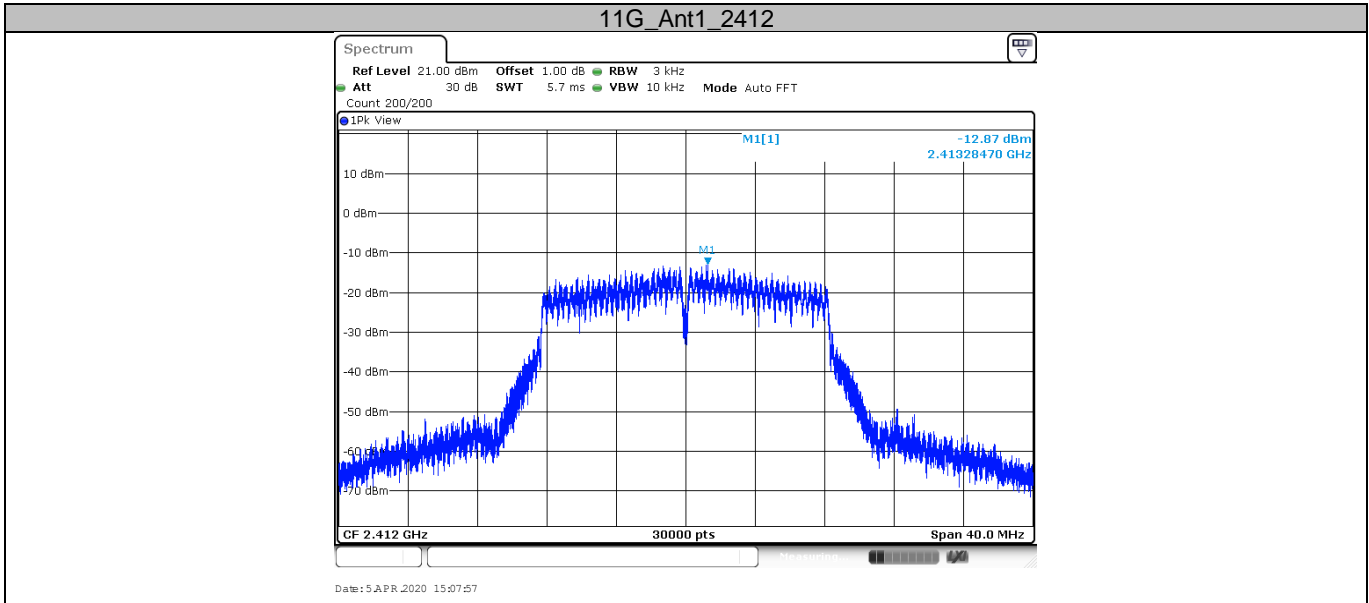

11N20SISO_Ant1_2412

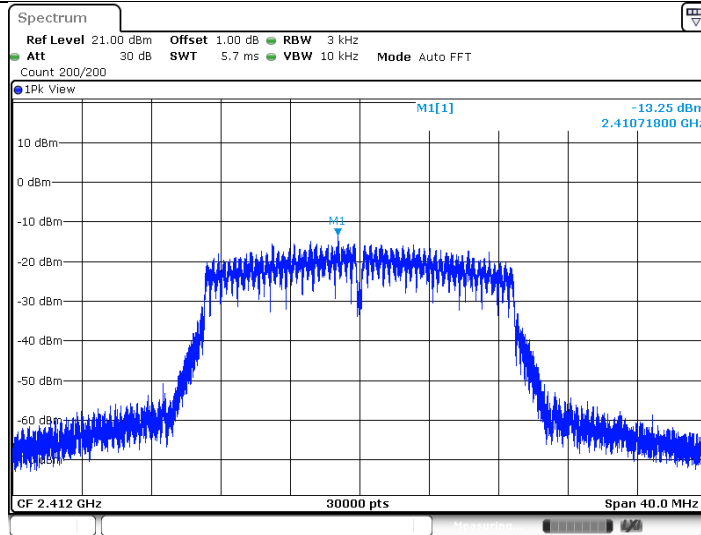

Date: 5 APR 2020 15:06:27

11N20SISO_Ant1_2437

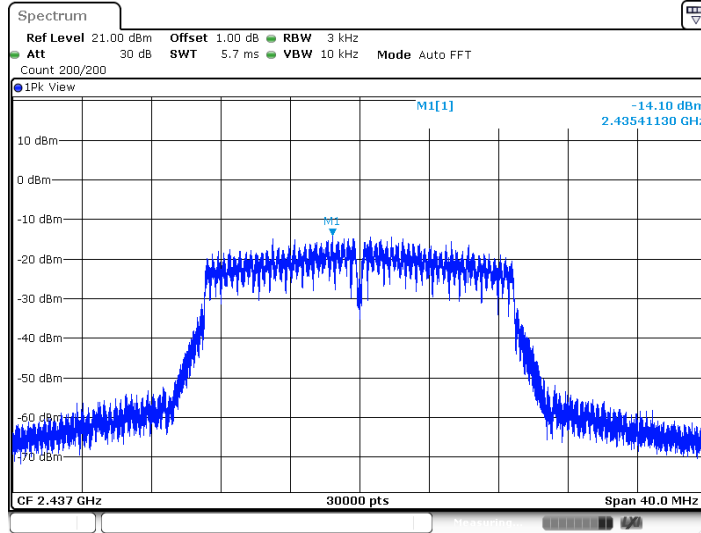

Date: 5 APR 2020 15:08:22

11N20SISO_Ant1_2462

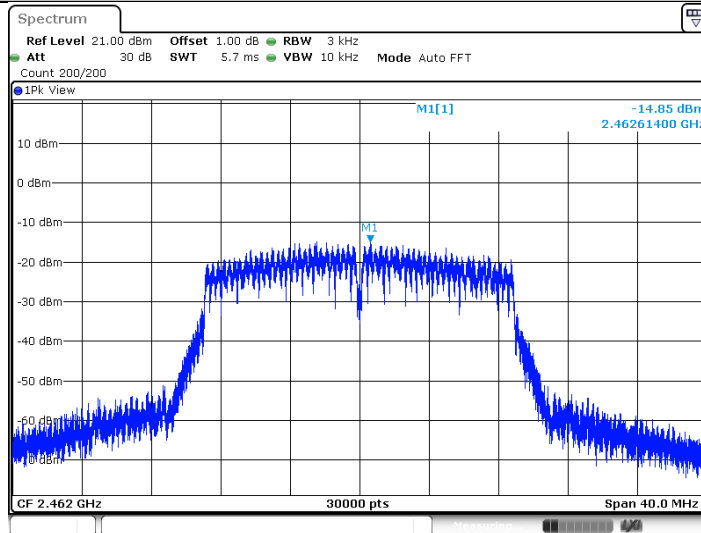

Date: 5 APR 2020 15:07:12

11N40SISO_Ant1_2422

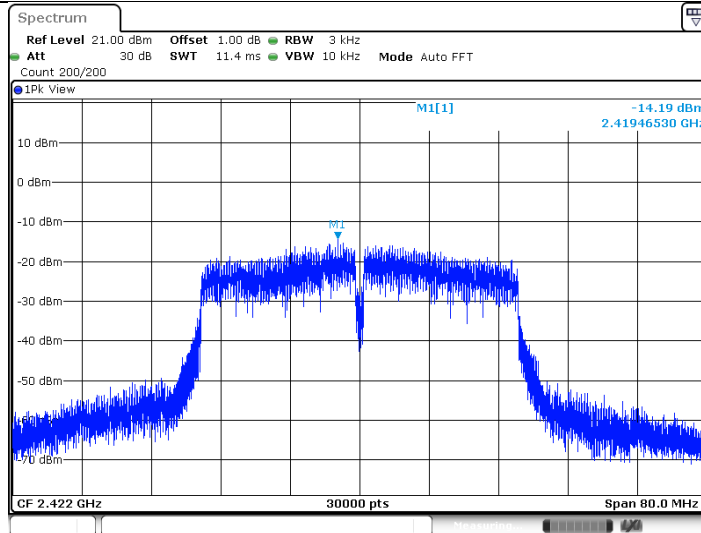

Date: 5 APR 2020 15:09:43

11N40SISO_Ant1_2437

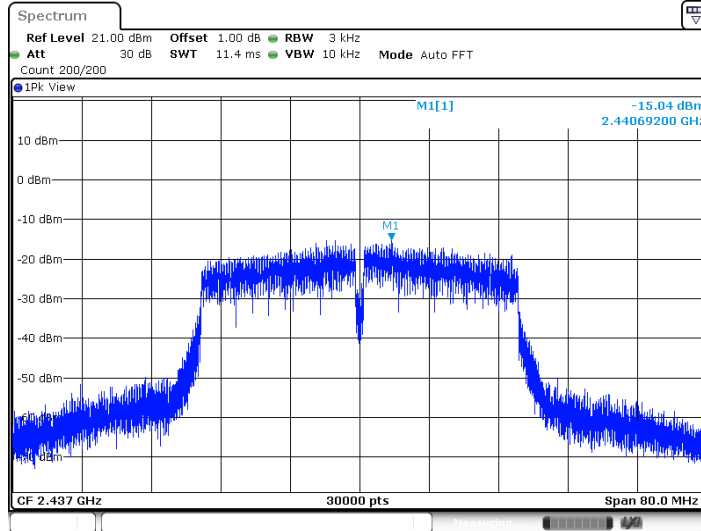

Date: 5 APR 2020 15:11:29

11N40SISO_Ant1_2452

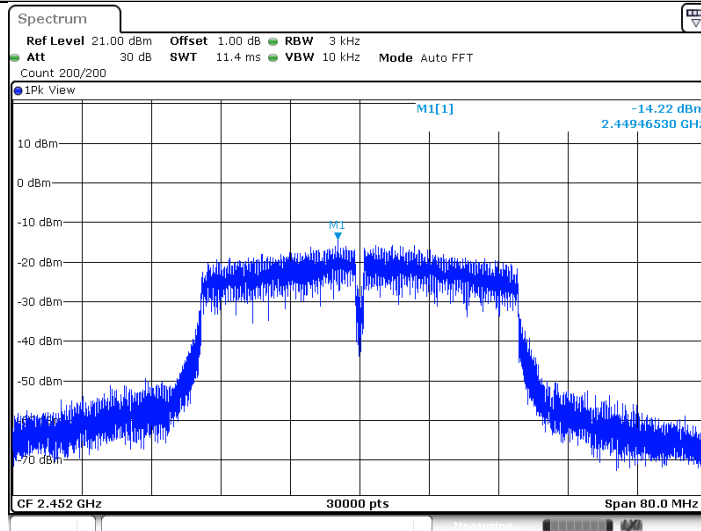

Date: 5 APR 2020 15:13:20

9.5 Spurious RF conducted emissions

Test Method

1. Use the following spectrum analyzer settings:
Span = wide enough to capture the peak level of the in-band emission and all spurious emissions (e.g., harmonics) from the lowest frequency generated in the EUT up through the 10th harmonic. Typically, several plots are required to cover this entire span.
RBW = 100 kHz, VBW ≥ RBW, Sweep = auto, Detector function = peak, Trace = max hold
2. Allow the trace to stabilize. Set the marker on the peak of any spurious emission recorded.
3. The level displayed must comply with the limit specified in this Section. Submit these plots.
4. Repeat above procedures until all frequencies measured were complete.

Limit

Frequency Range MHz	Limit (dBc)
30-25000	-20

Spurious RF conducted emissions

TestMode	Antenna	Channel(MHz)	FreqRange(MHz)	RefLevel(MHz)	Result(dBm)	Limit(dBm)	Verdict
11B	Ant1	2412	Reference	5.73	5.73	---	PASS
		2412	30~1000	30~1000	-59.15	<=-14.27	PASS
		2412	1000~26500	1000~26500	-52.36	<=-14.27	PASS
		2437	Reference	5.42	5.42	---	PASS
		2437	30~1000	30~1000	-59.57	<=-14.58	PASS
		2437	1000~26500	1000~26500	-44.23	<=-14.58	PASS
		2462	Reference	5.89	5.89	---	PASS
		2462	30~1000	30~1000	-57.51	<=-14.11	PASS
11G	Ant1	2412	Reference	1.73	1.73	---	PASS
		2412	30~1000	30~1000	-59.7	<=-18.27	PASS
		2412	1000~26500	1000~26500	-52.16	<=-18.27	PASS
		2437	Reference	3.81	3.81	---	PASS
		2437	30~1000	30~1000	-59.04	<=-16.19	PASS
		2437	1000~26500	1000~26500	-52.02	<=-16.19	PASS
		2462	Reference	1.33	1.33	---	PASS
		2462	30~1000	30~1000	-57.39	<=-18.67	PASS
11N20SISO	Ant1	2412	Reference	3.33	3.33	---	PASS
		2412	30~1000	30~1000	-62.66	<=-16.67	PASS
		2412	1000~26500	1000~26500	-52.18	<=-16.67	PASS
		2437	Reference	1.59	1.59	---	PASS
		2437	30~1000	30~1000	-62.84	<=-18.41	PASS
		2437	1000~26500	1000~26500	-51.27	<=-18.41	PASS
		2462	Reference	2.13	2.13	---	PASS
		2462	30~1000	30~1000	-62.38	<=-17.87	PASS
11N40SISO	Ant1	2422	Reference	-2.87	-2.87	---	PASS
		2422	30~1000	30~1000	-58.55	<=-22.87	PASS
		2422	1000~26500	1000~26500	-52.73	<=-22.87	PASS
		2437	Reference	-2.72	-2.72	---	PASS
		2437	30~1000	30~1000	-57.5	<=-22.72	PASS
		2437	1000~26500	1000~26500	-52.24	<=-22.72	PASS
		2452	Reference	-2.07	-2.07	---	PASS
		2452	30~1000	30~1000	-58.83	<=-22.07	PASS
		2452	1000~26500	1000~26500	-52.58	<=-22.07	PASS

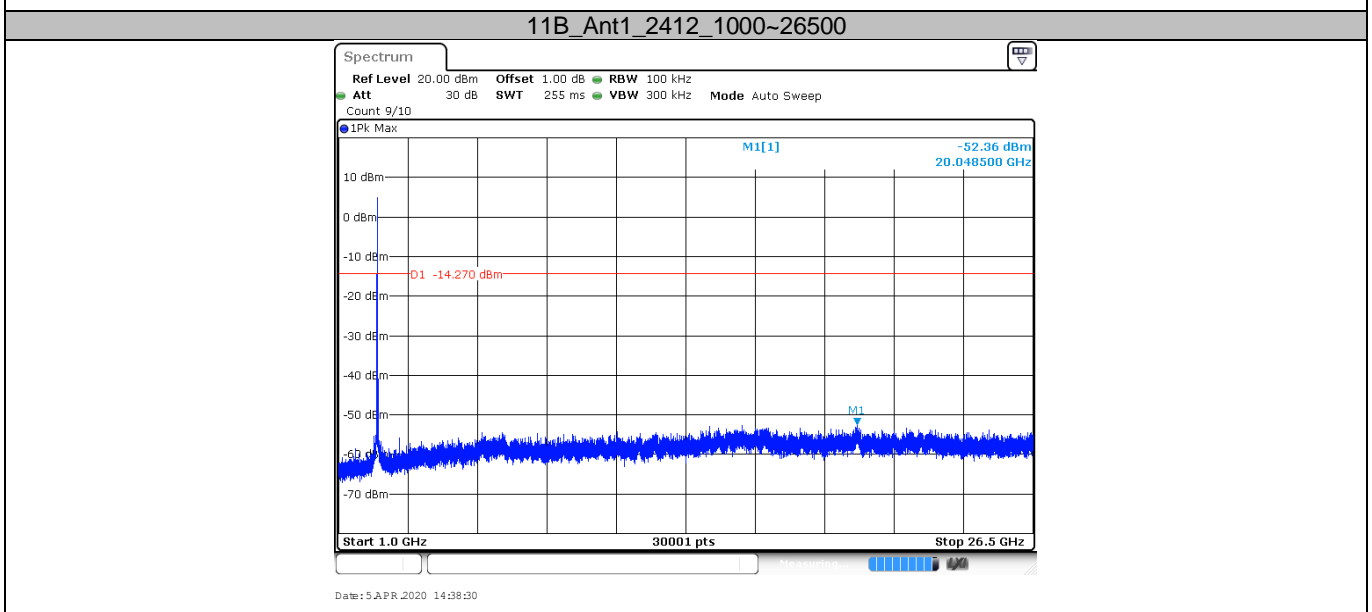
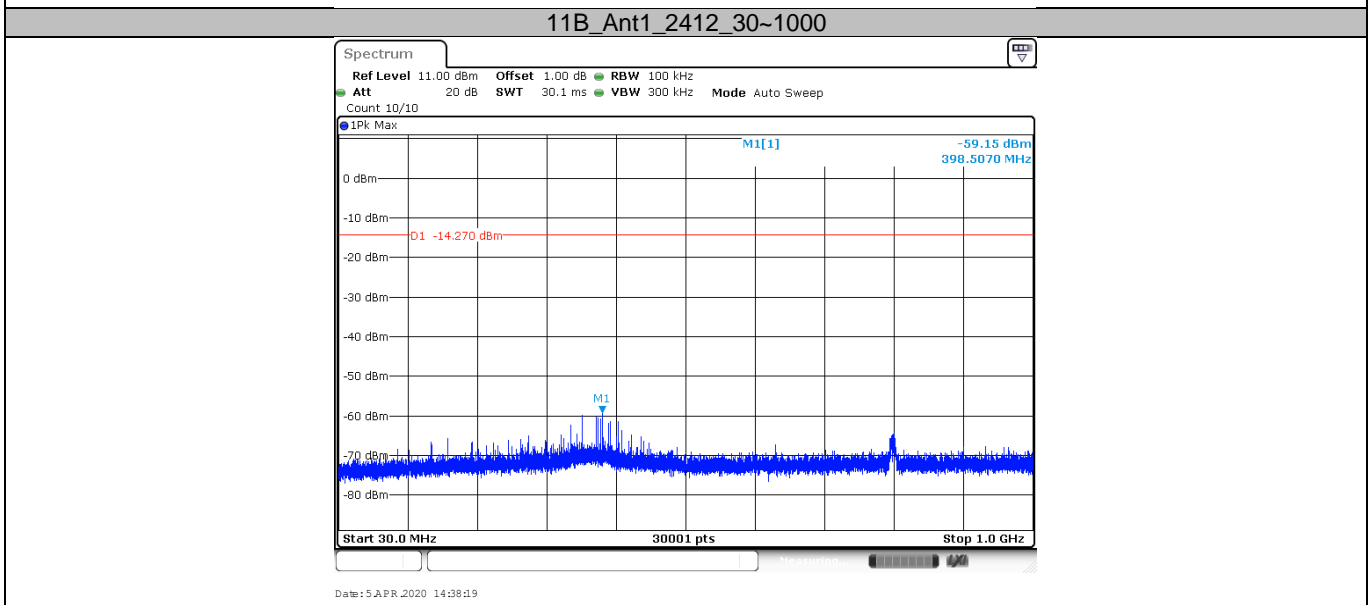
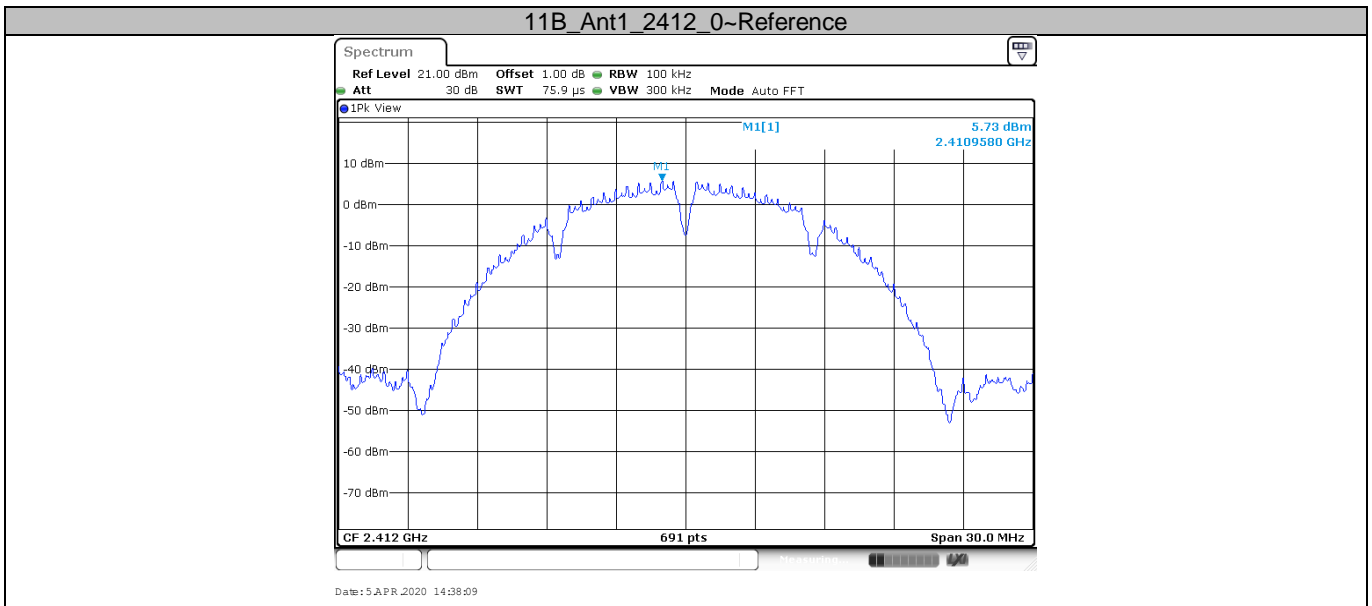

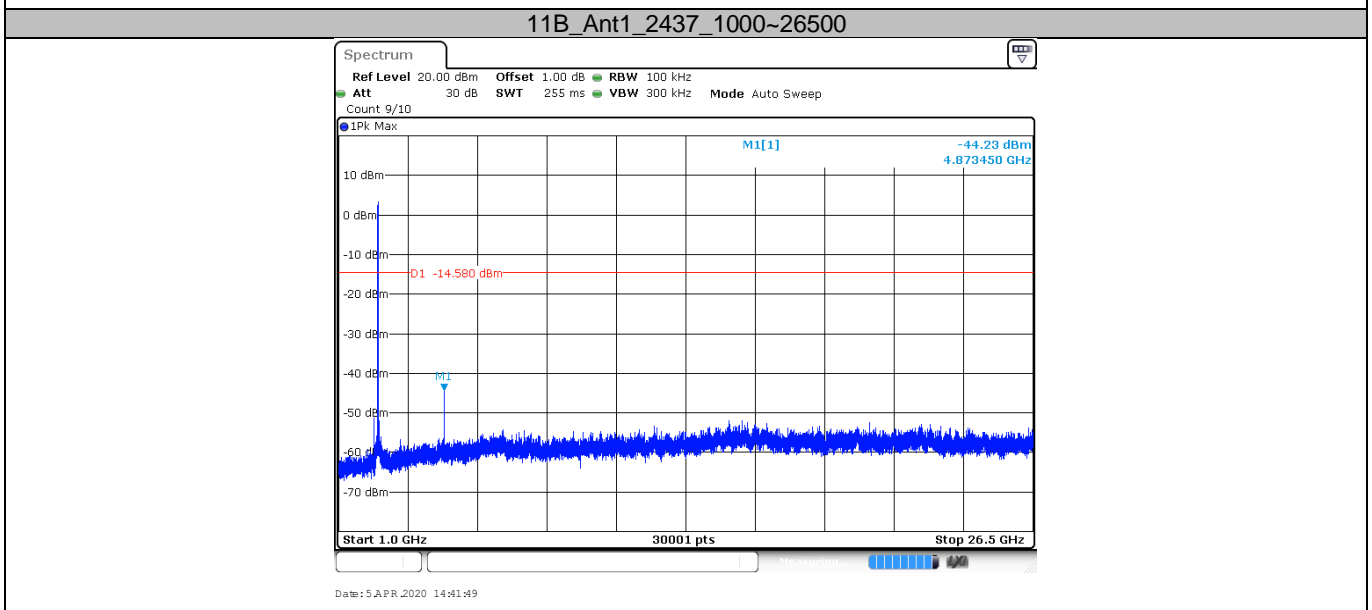
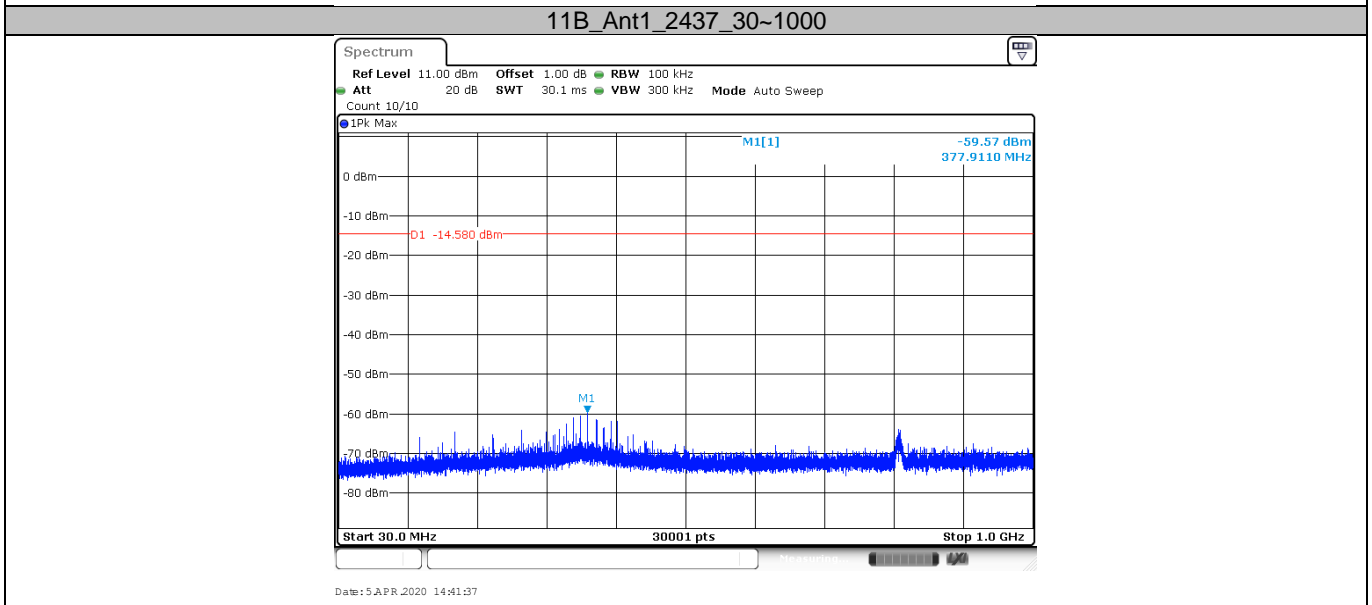
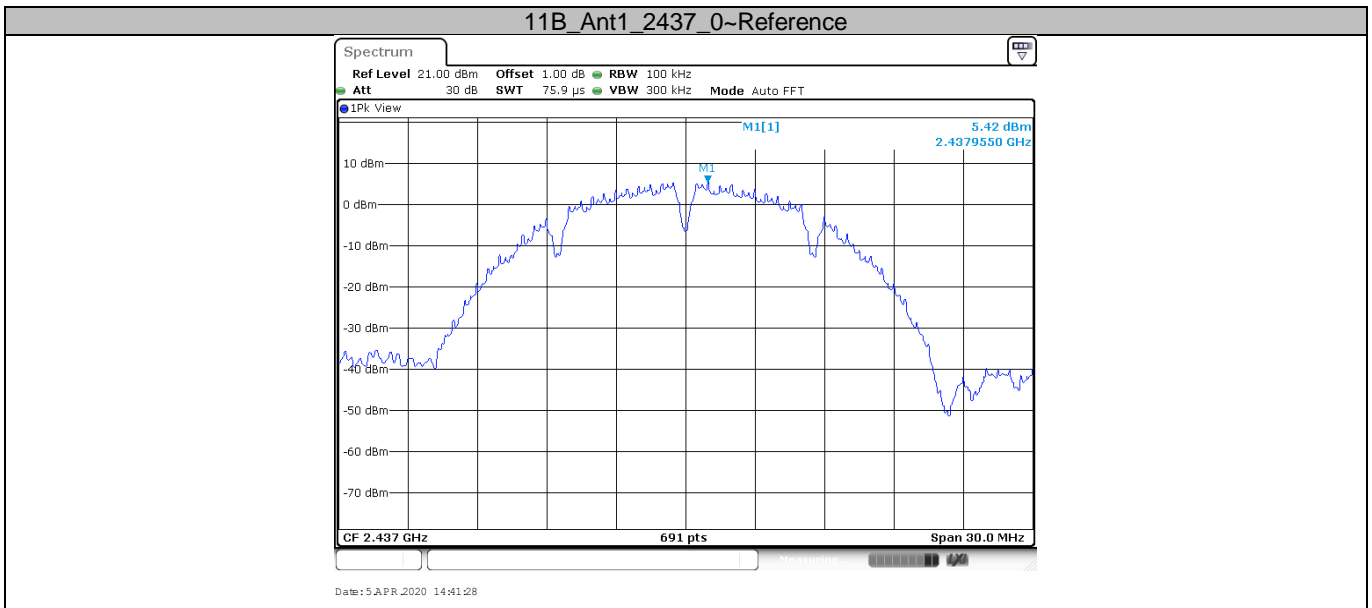

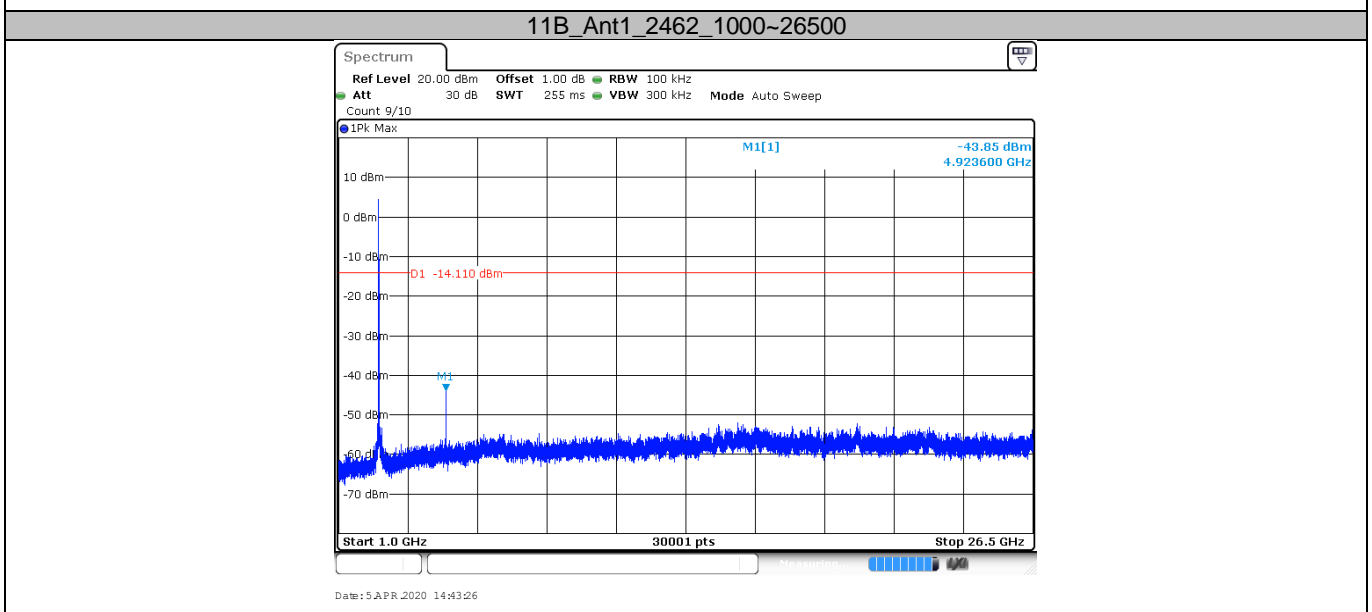
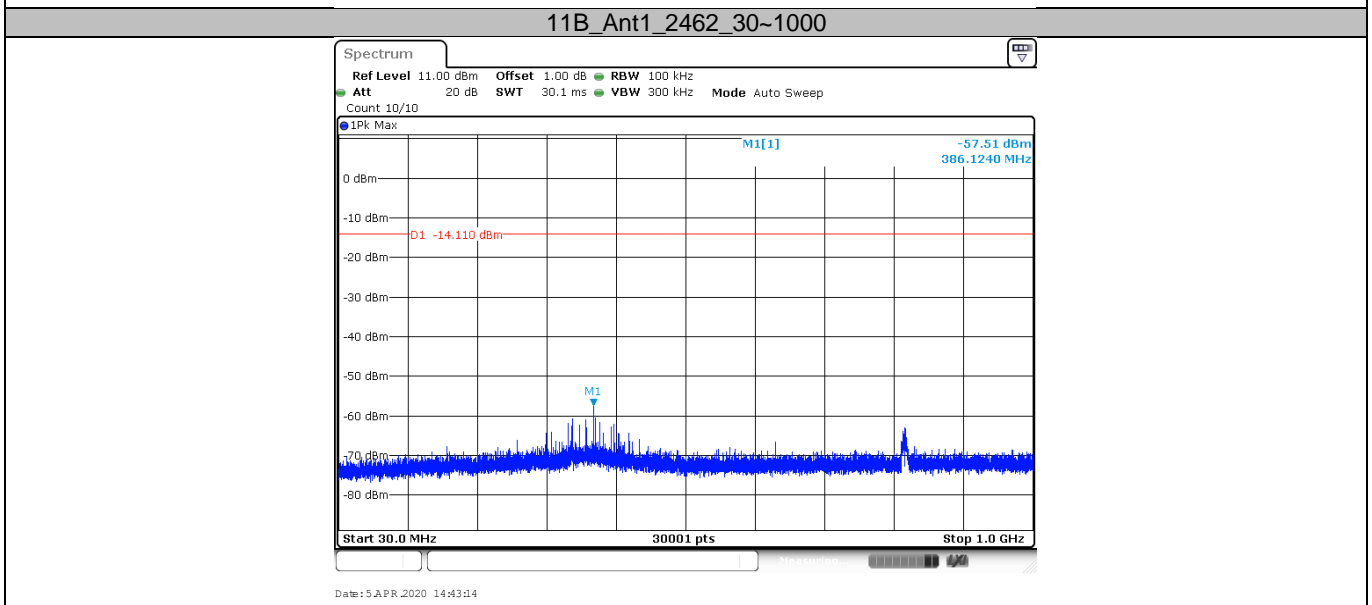
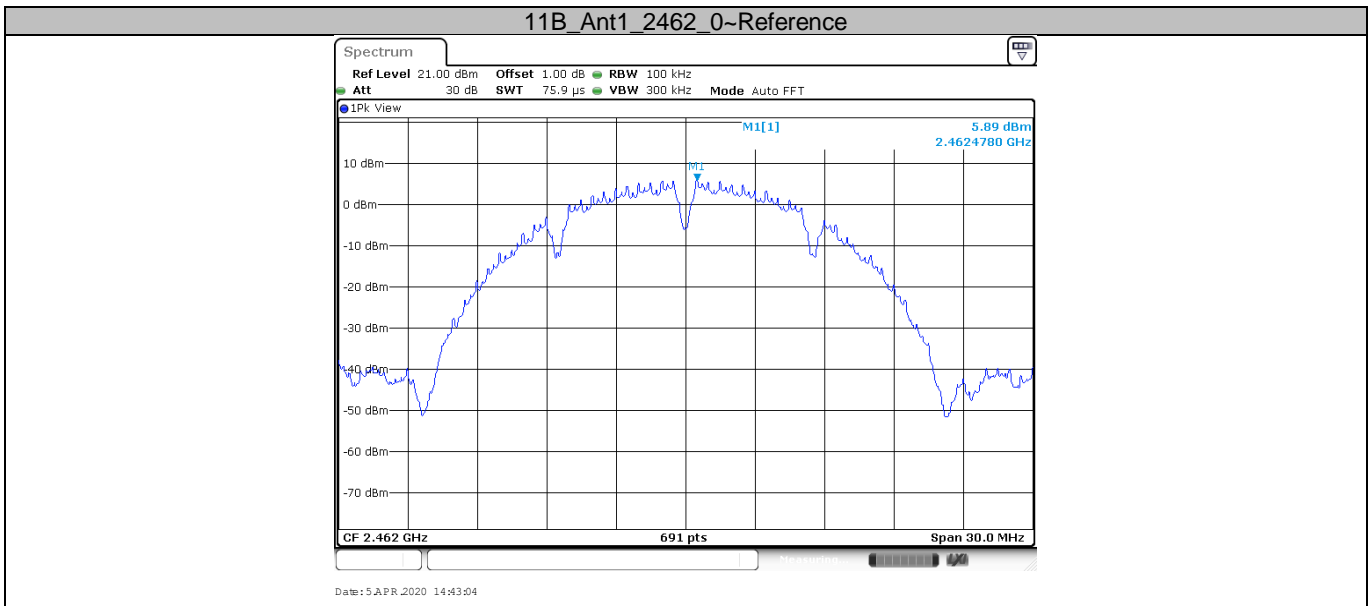

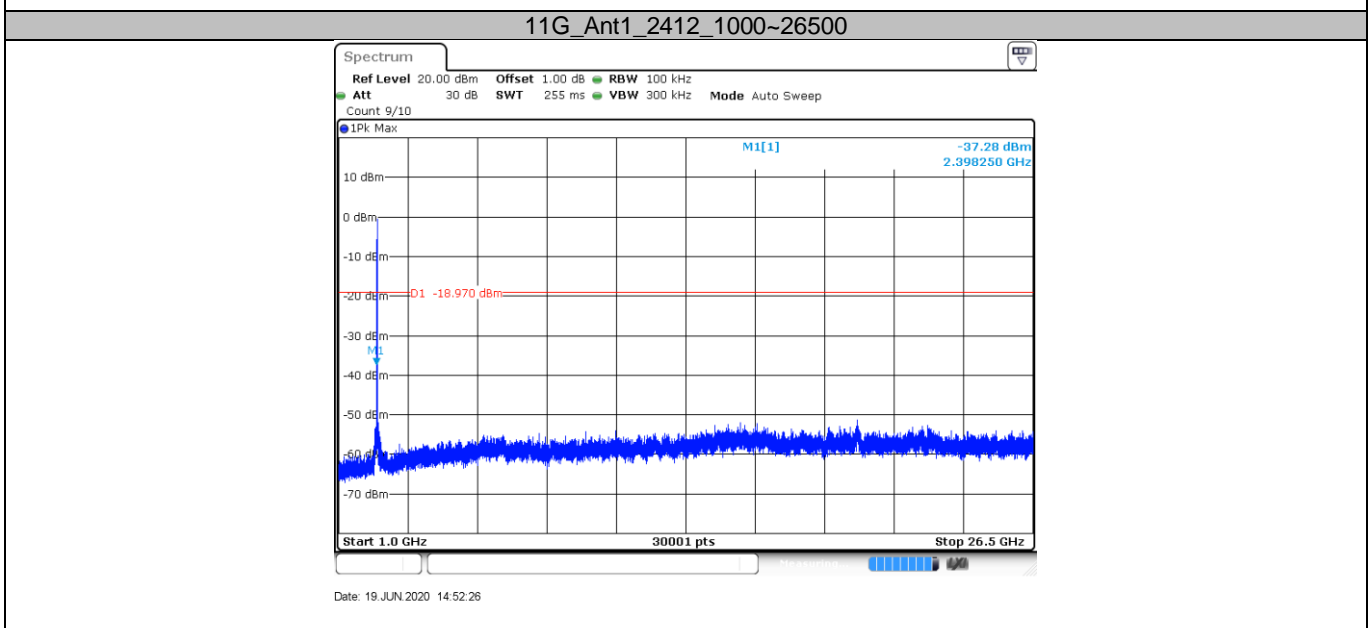
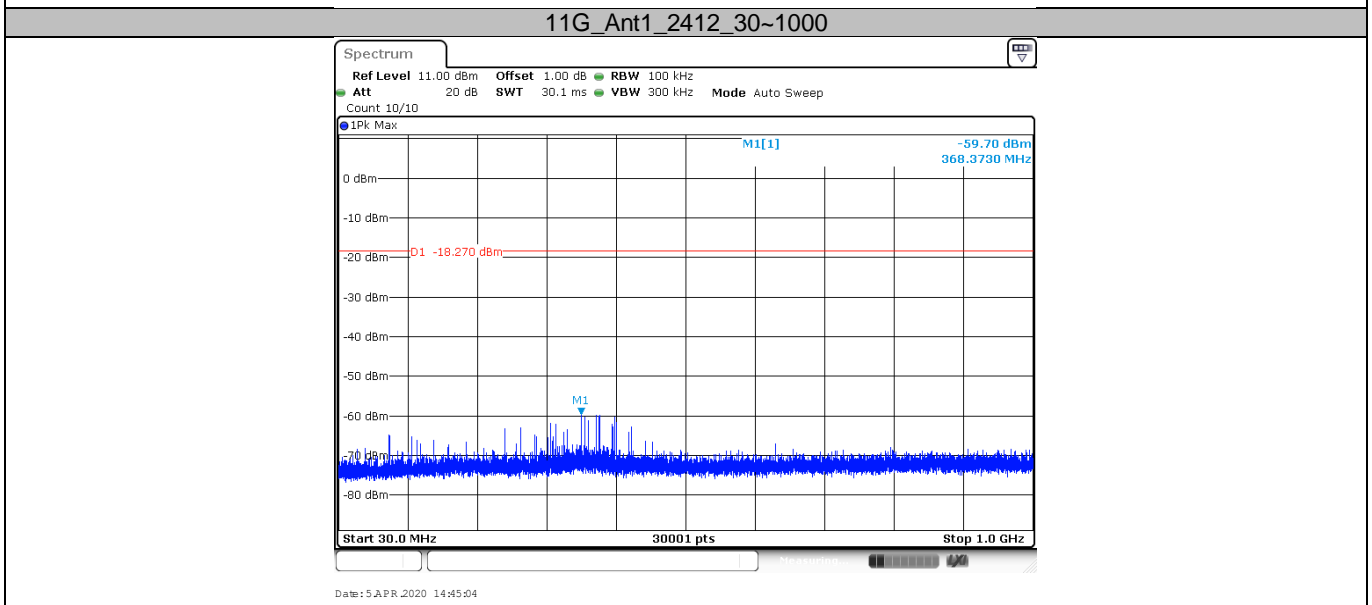
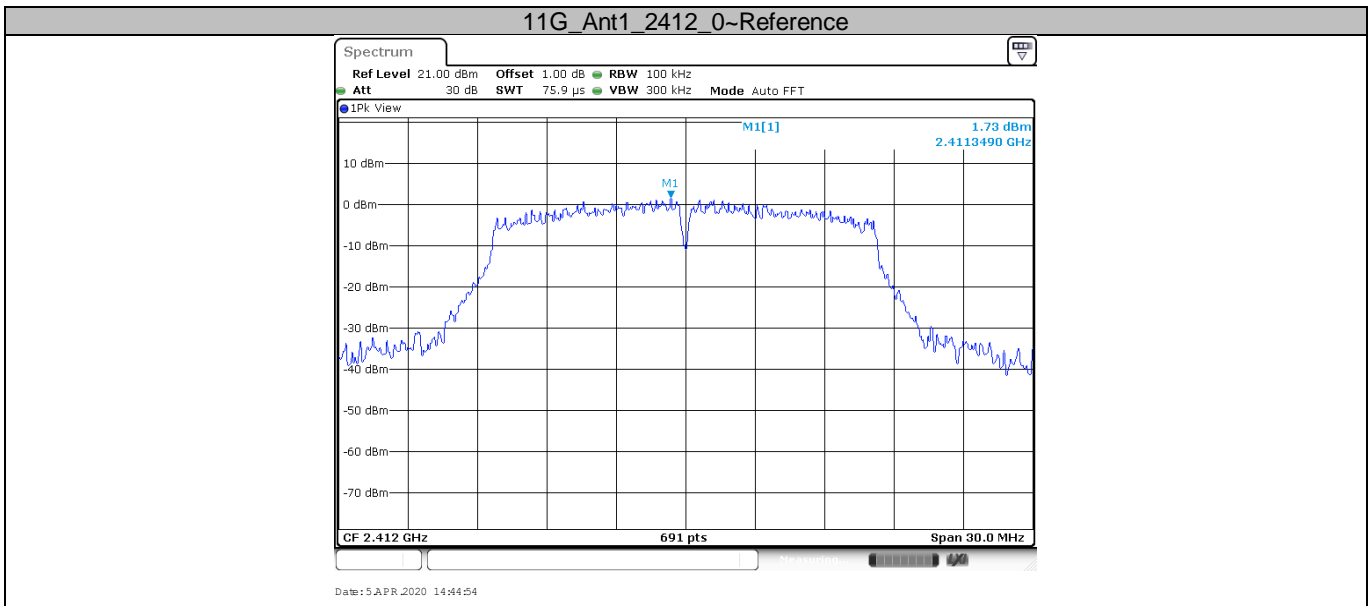

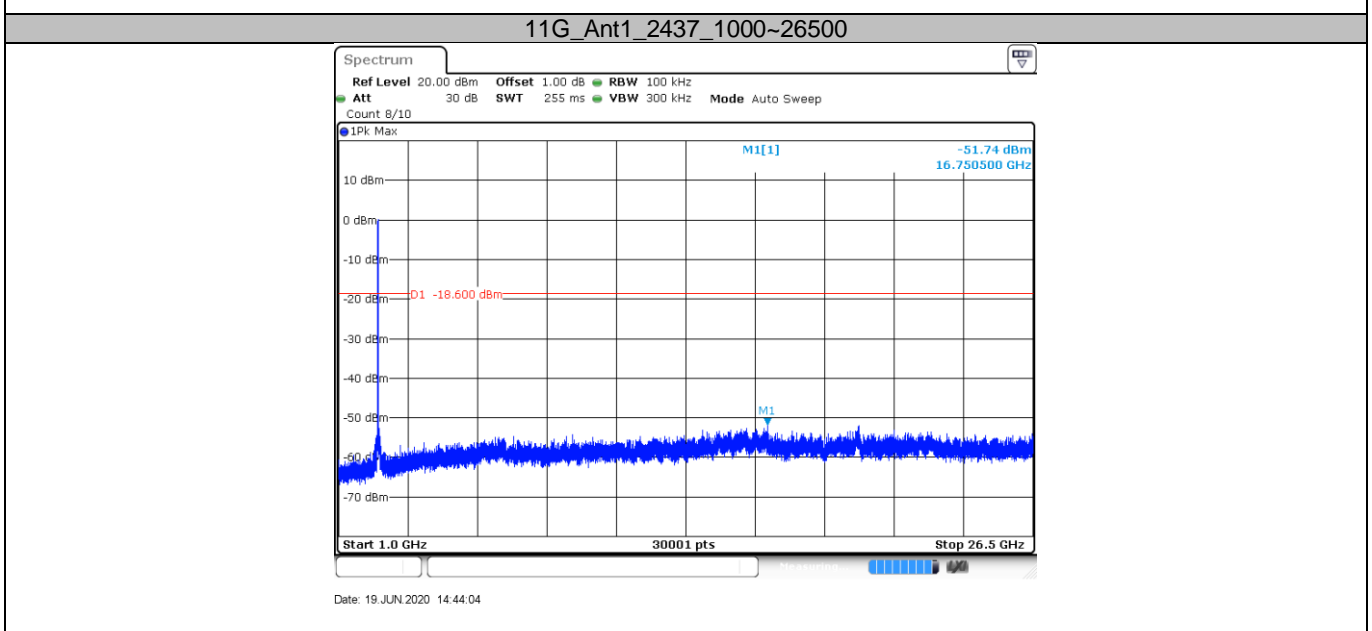
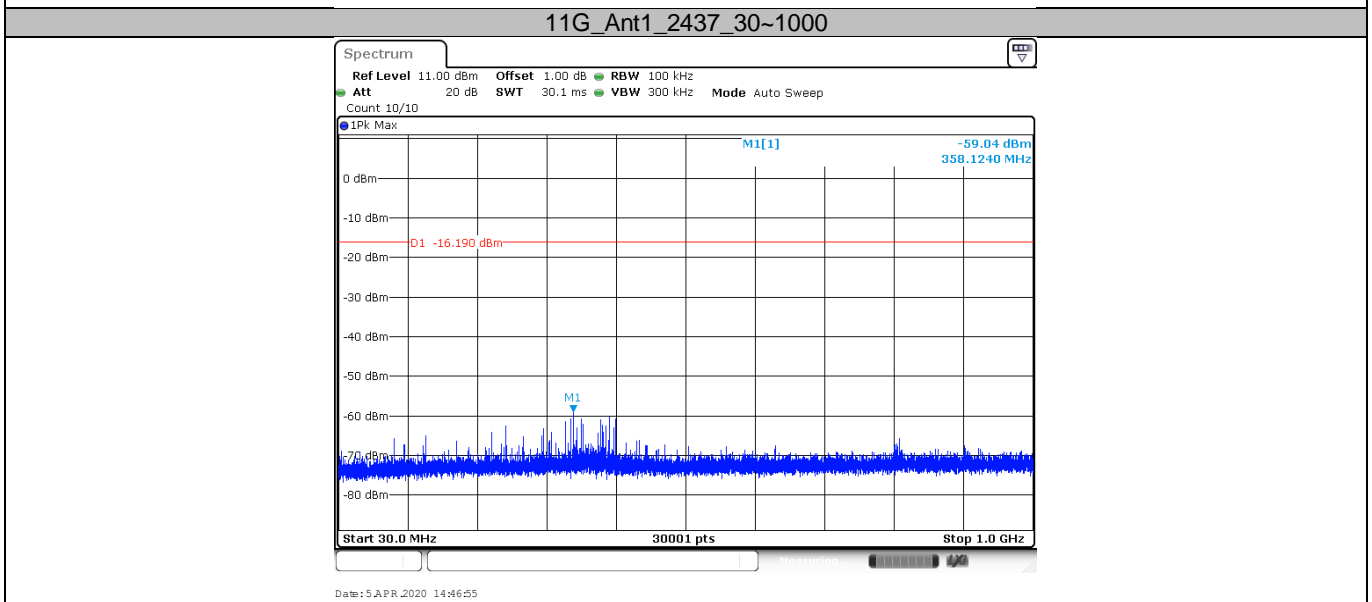
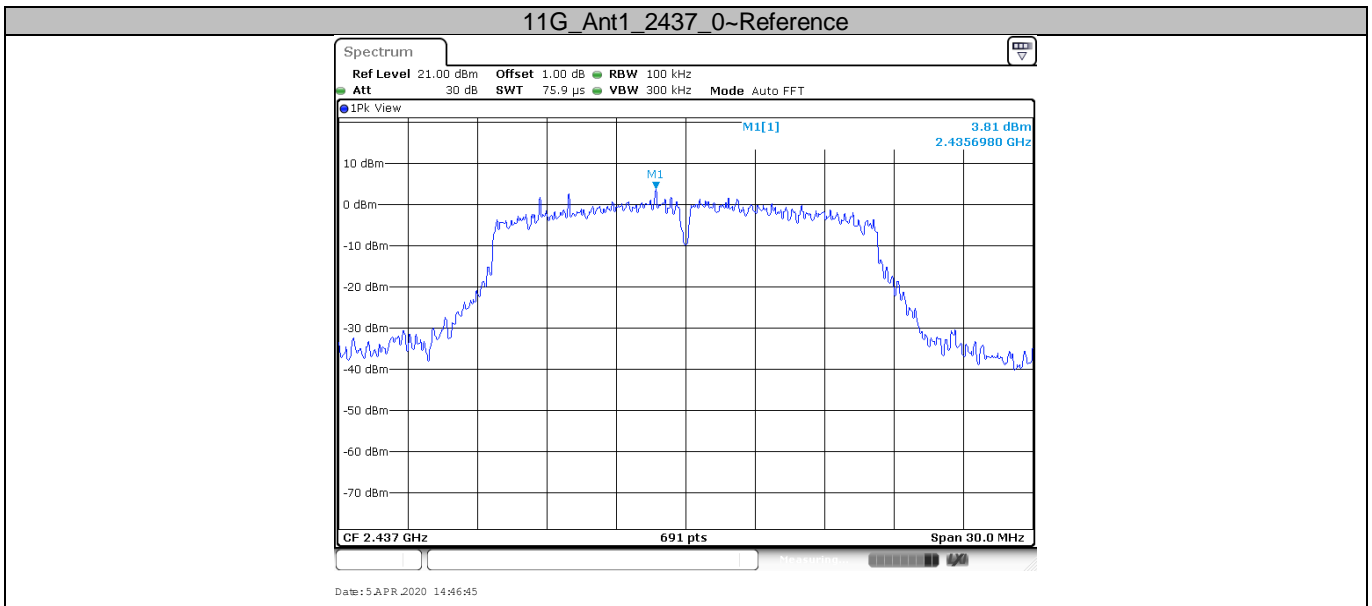

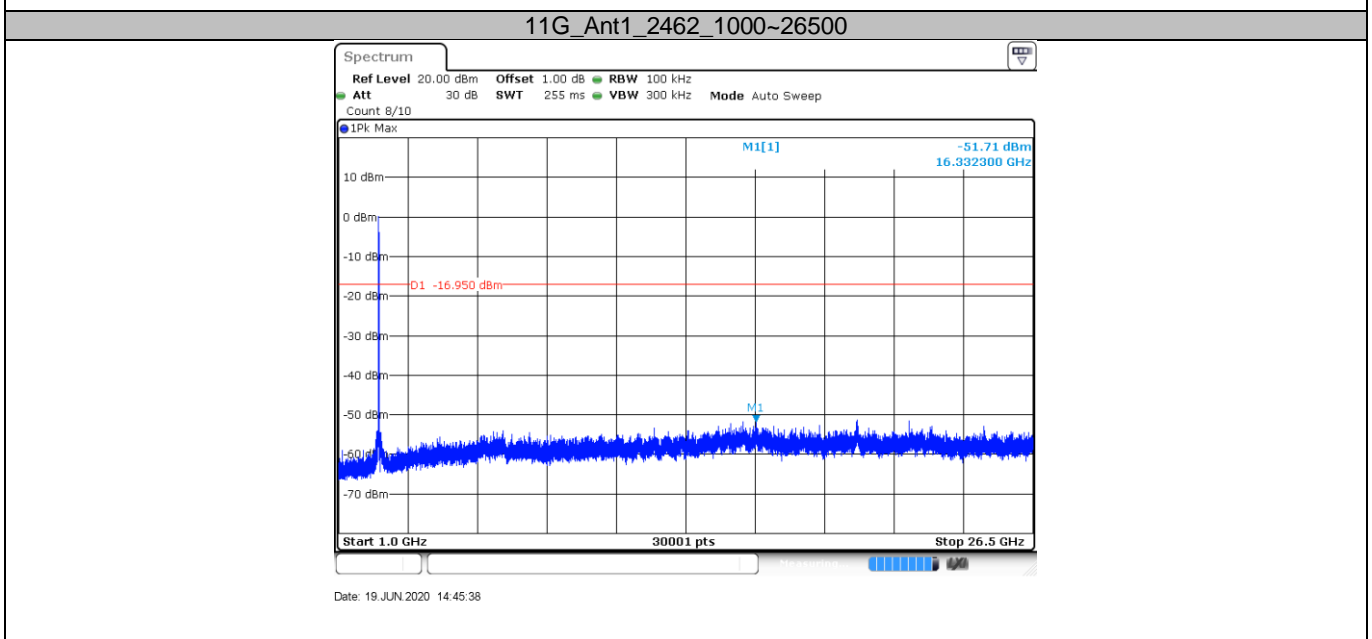
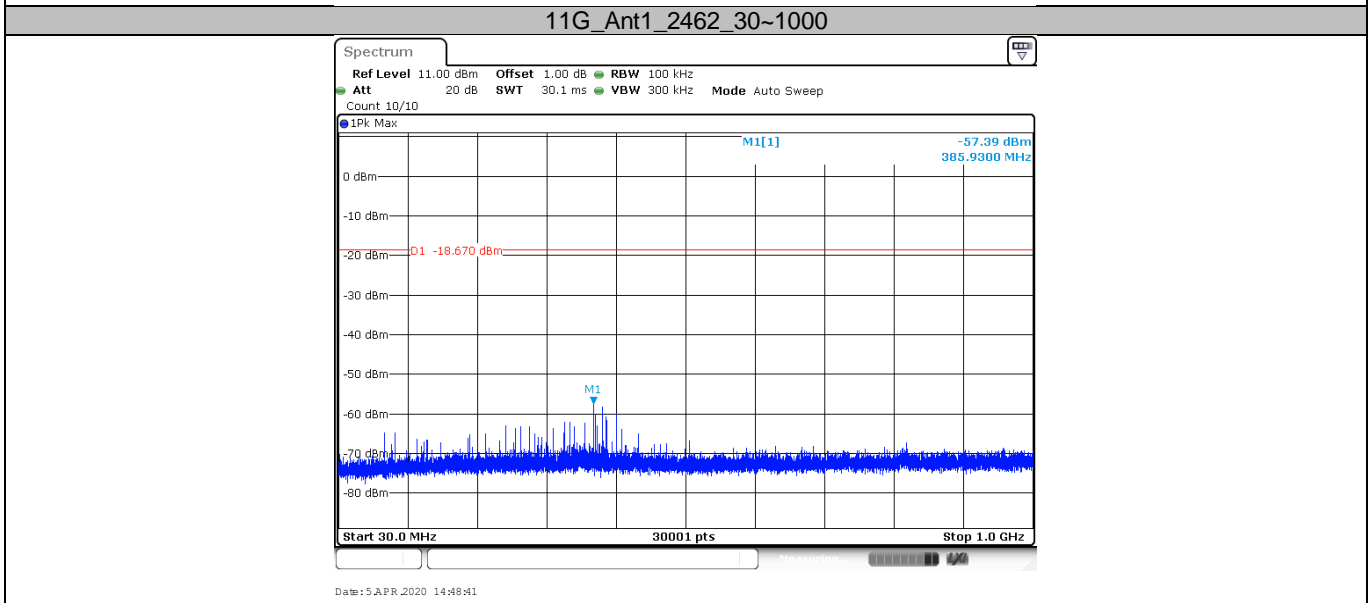
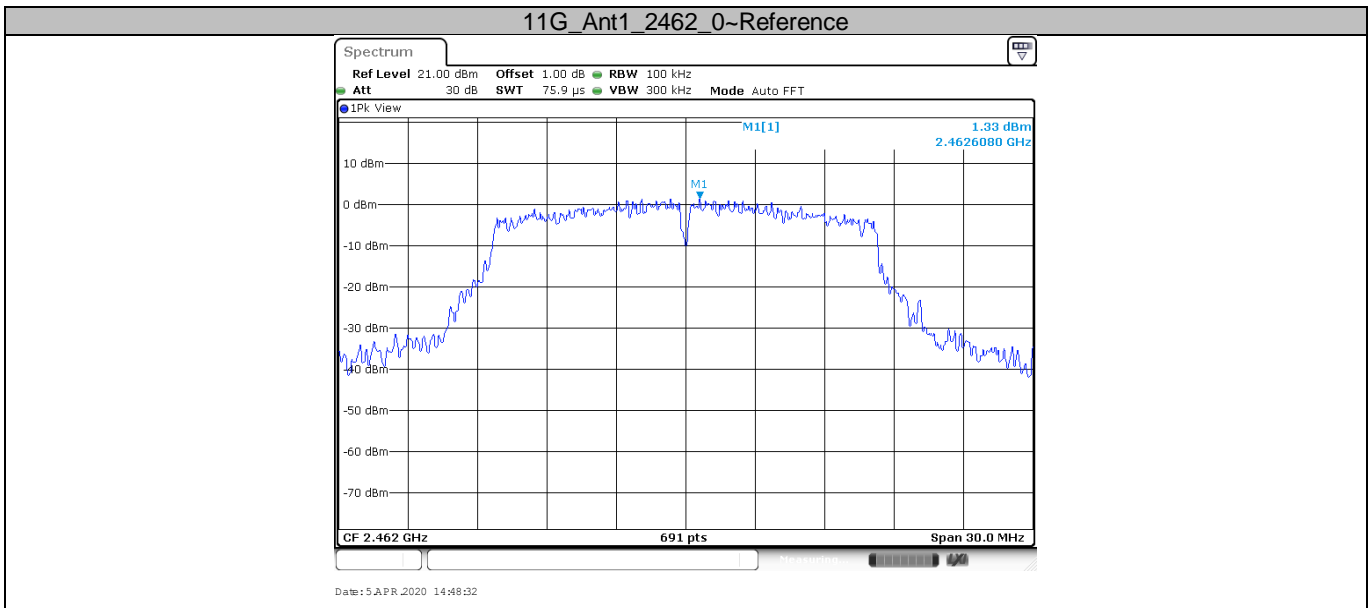

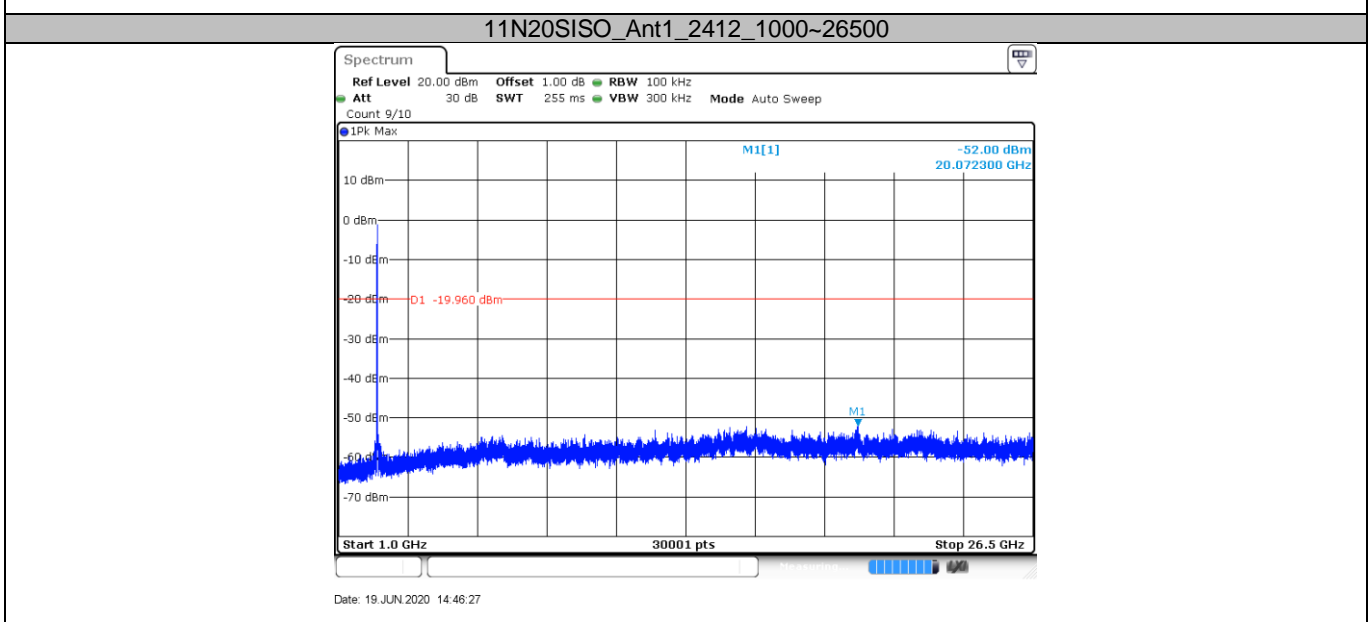
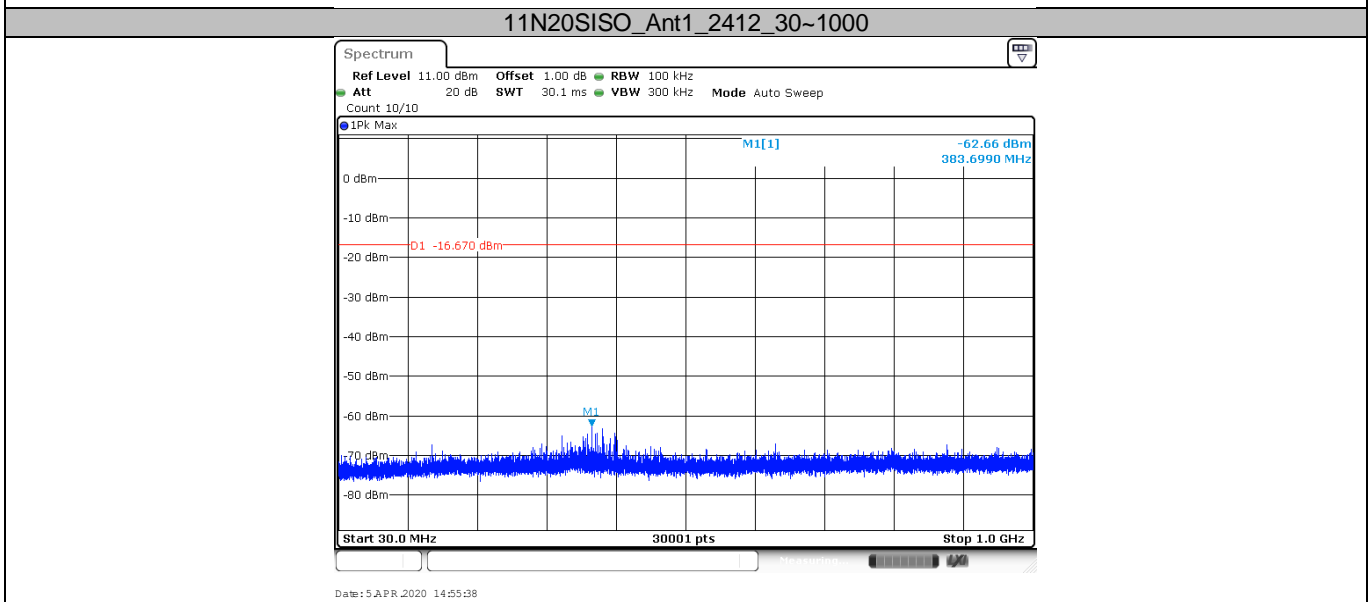
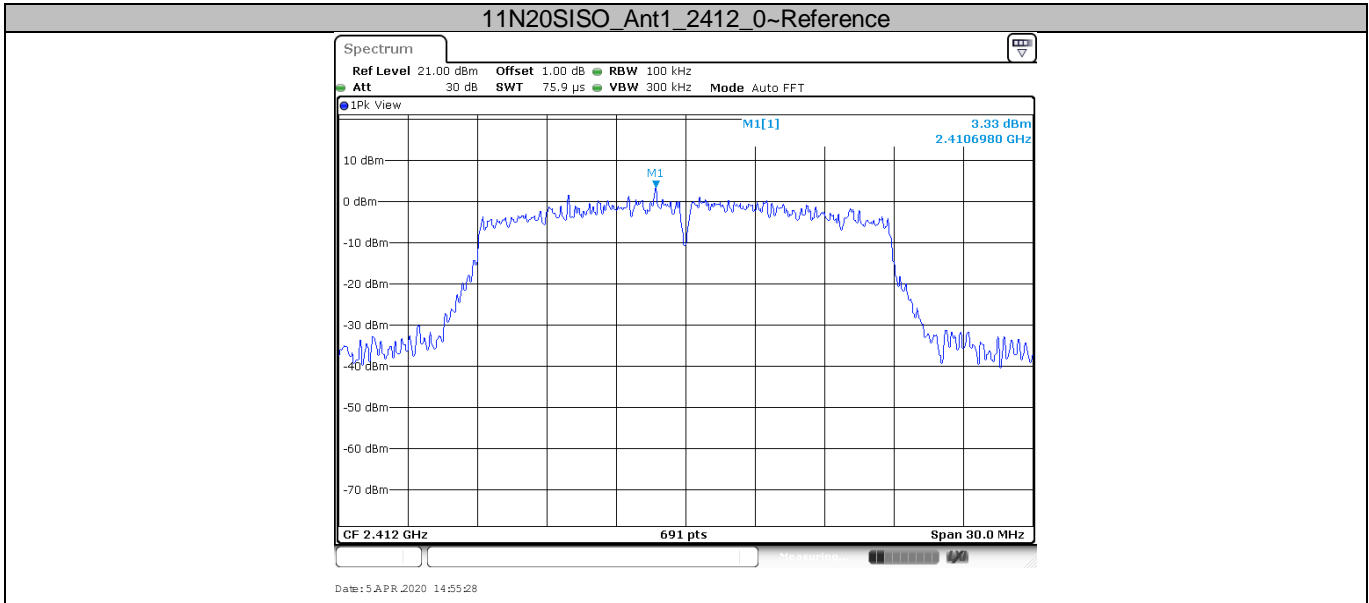

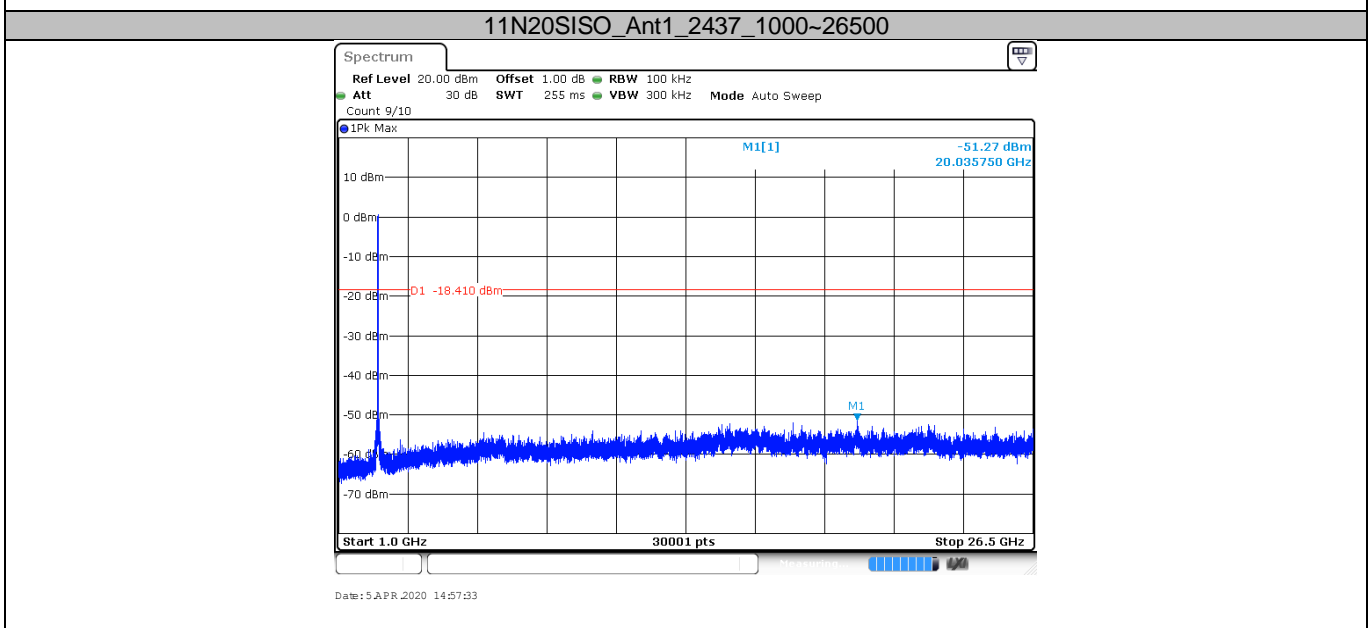
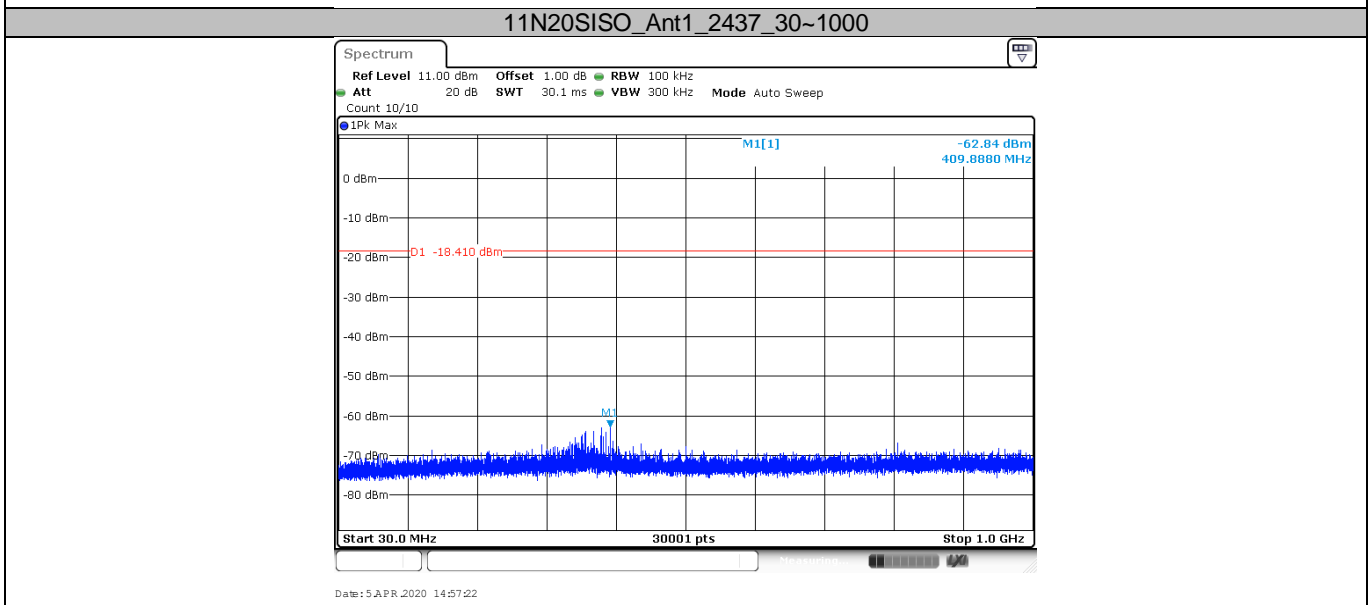
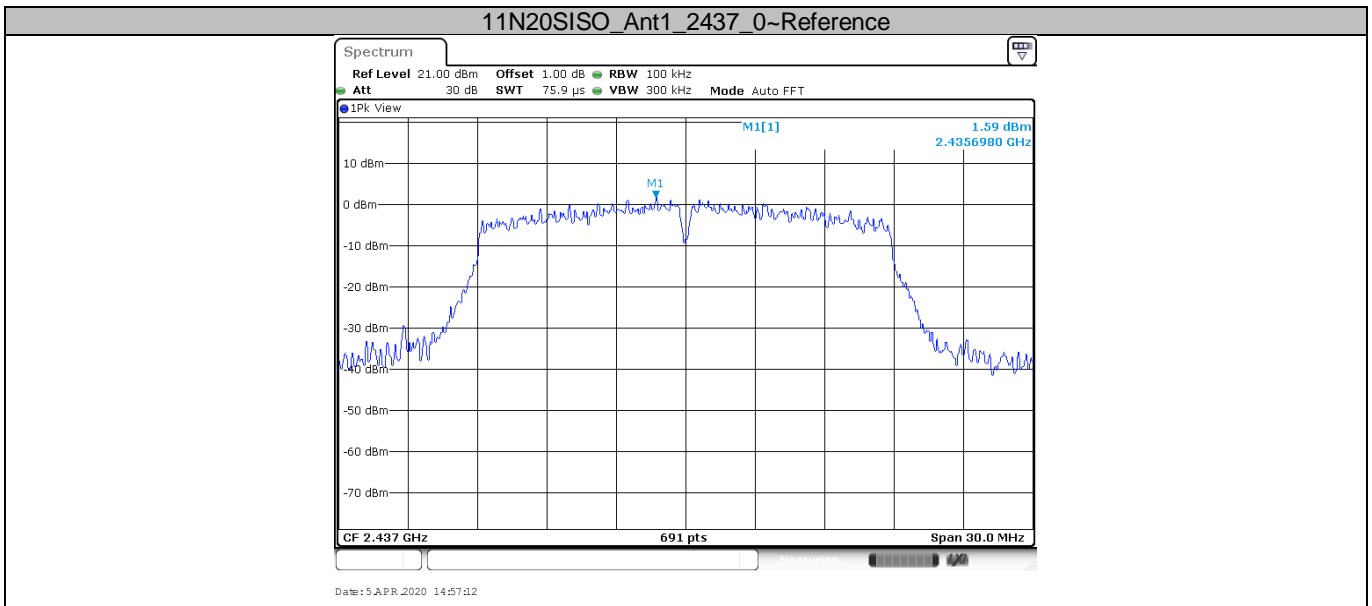

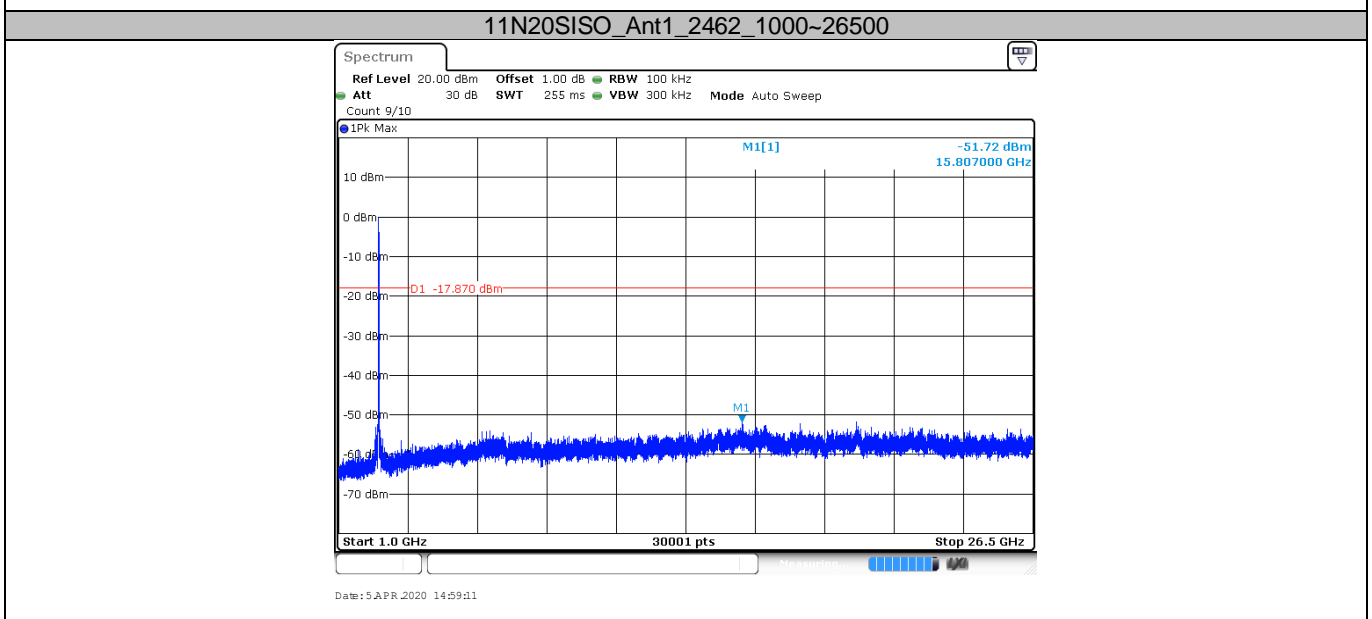
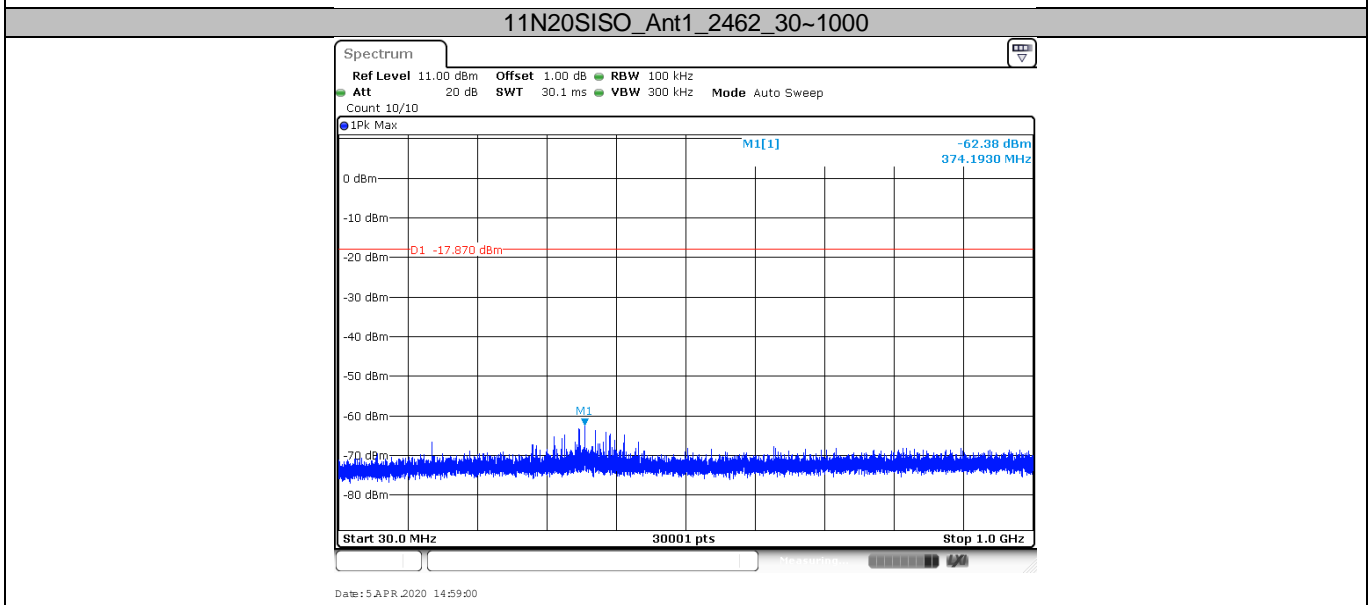
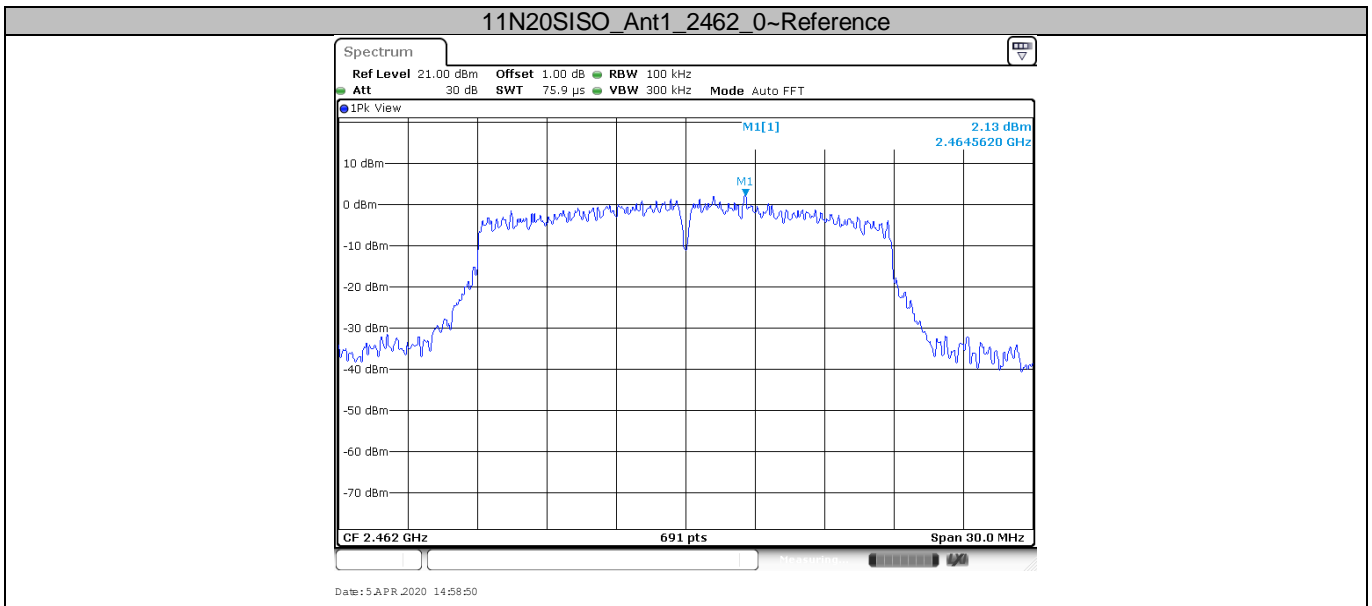

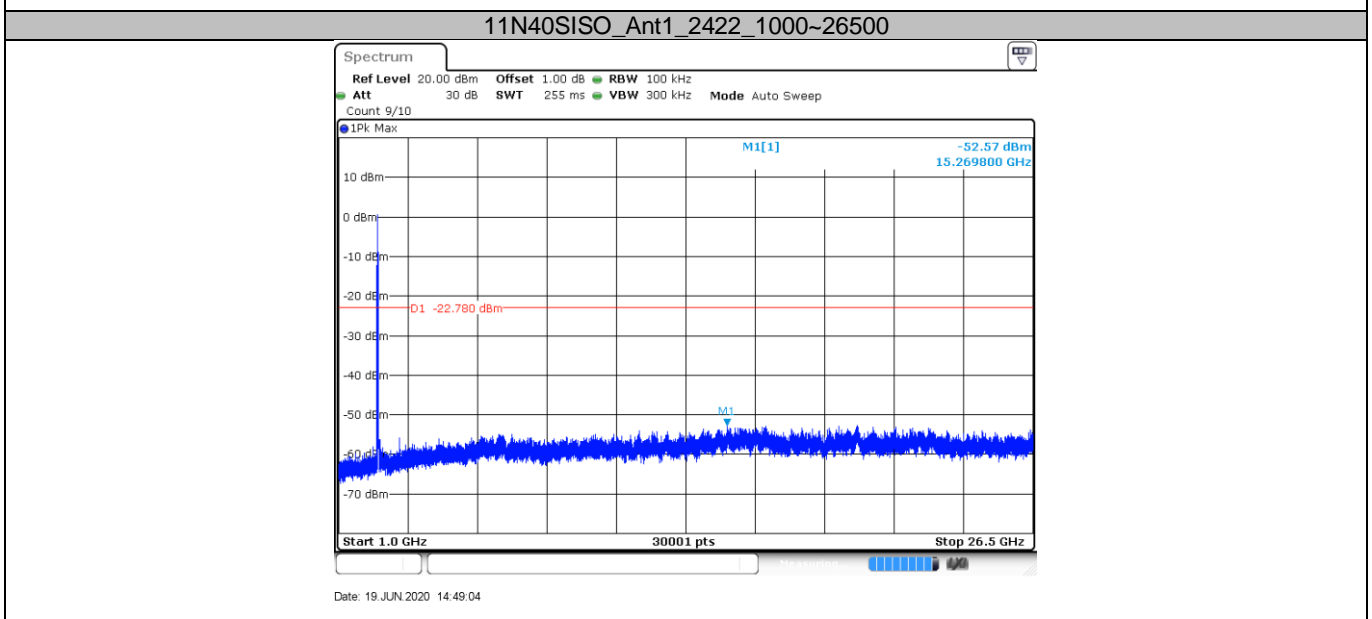
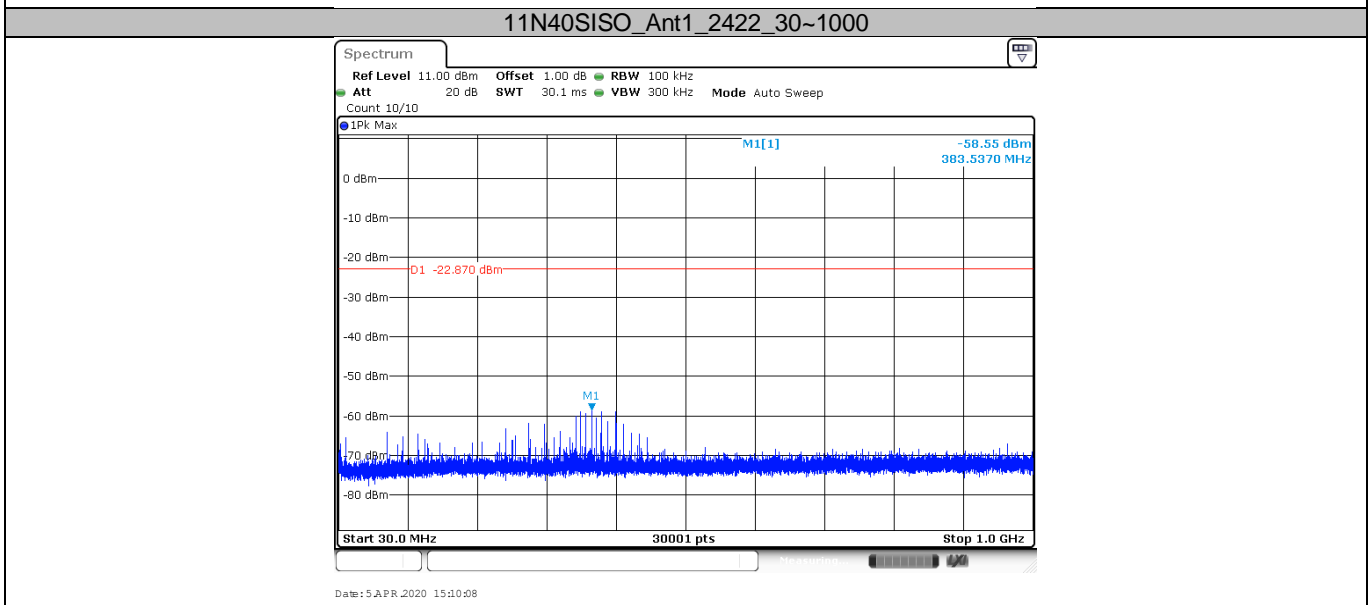
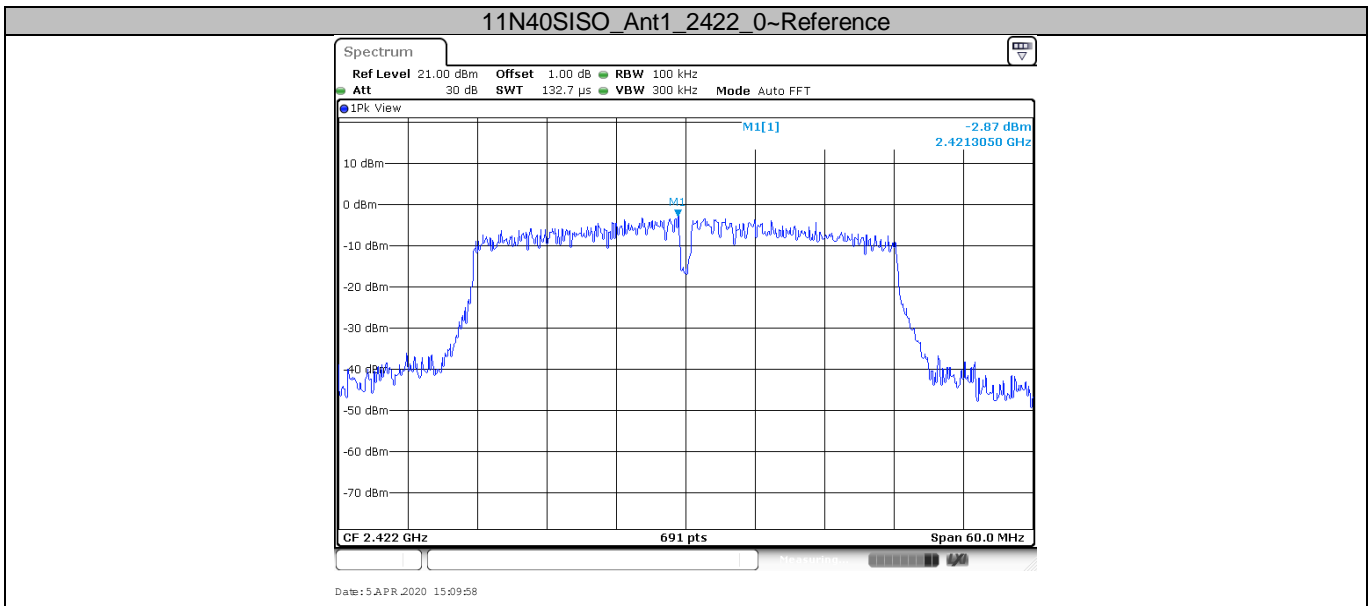

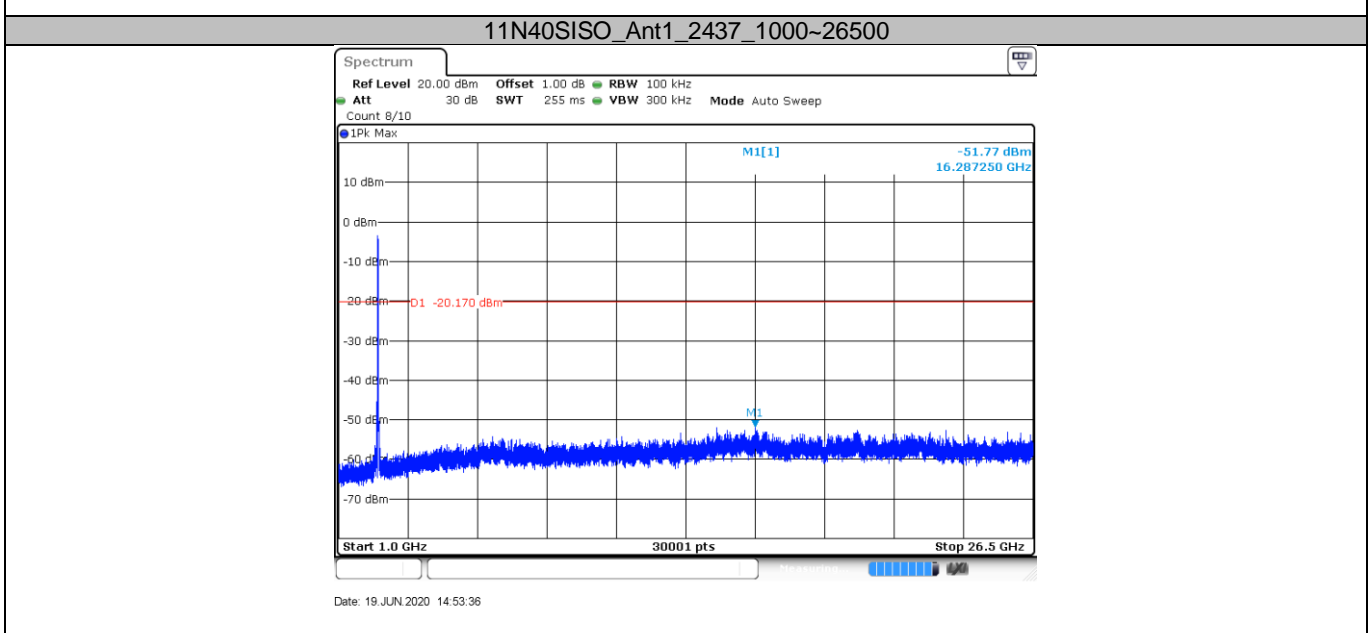
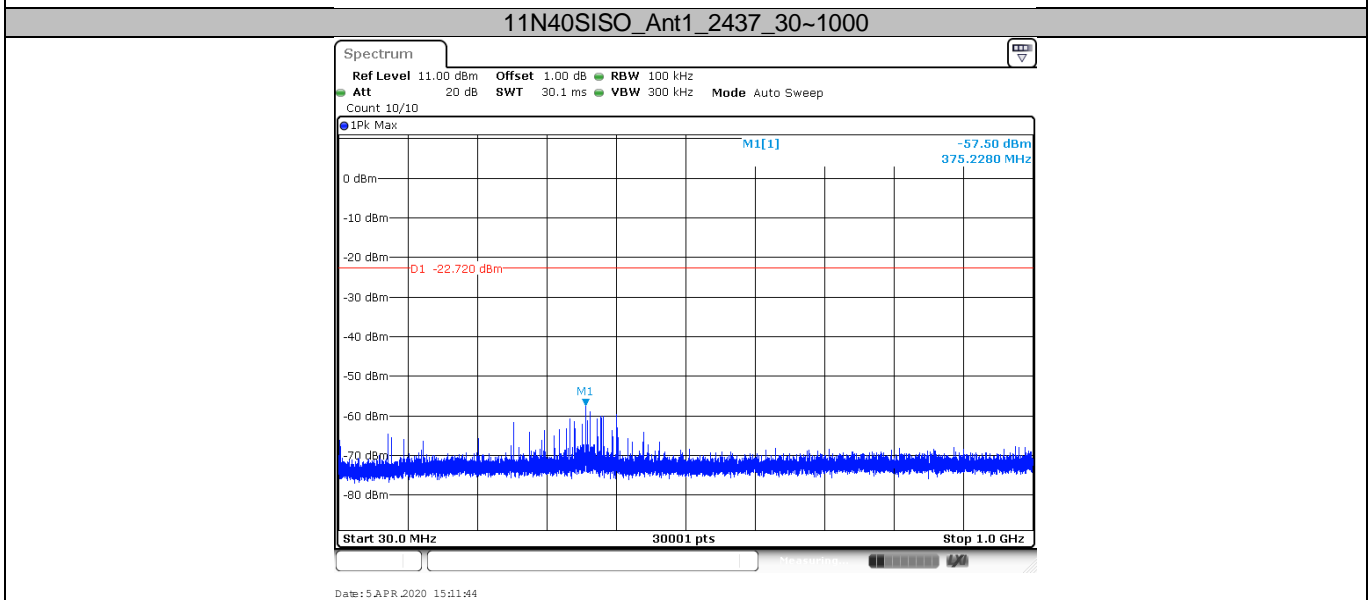
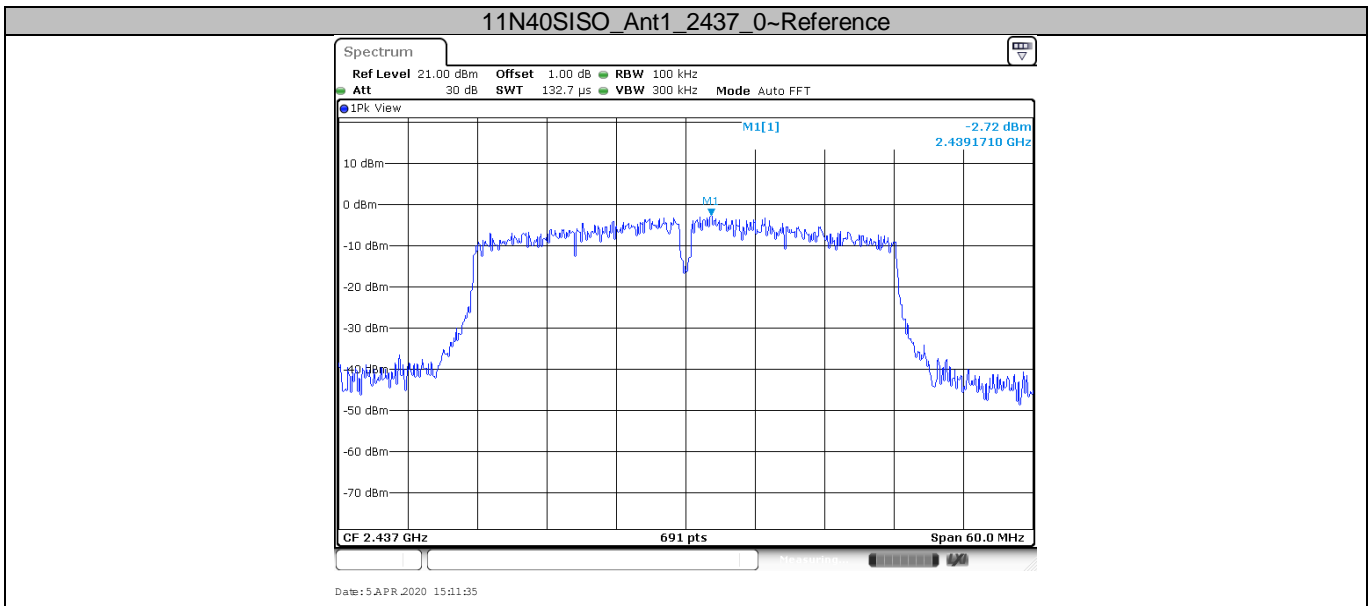

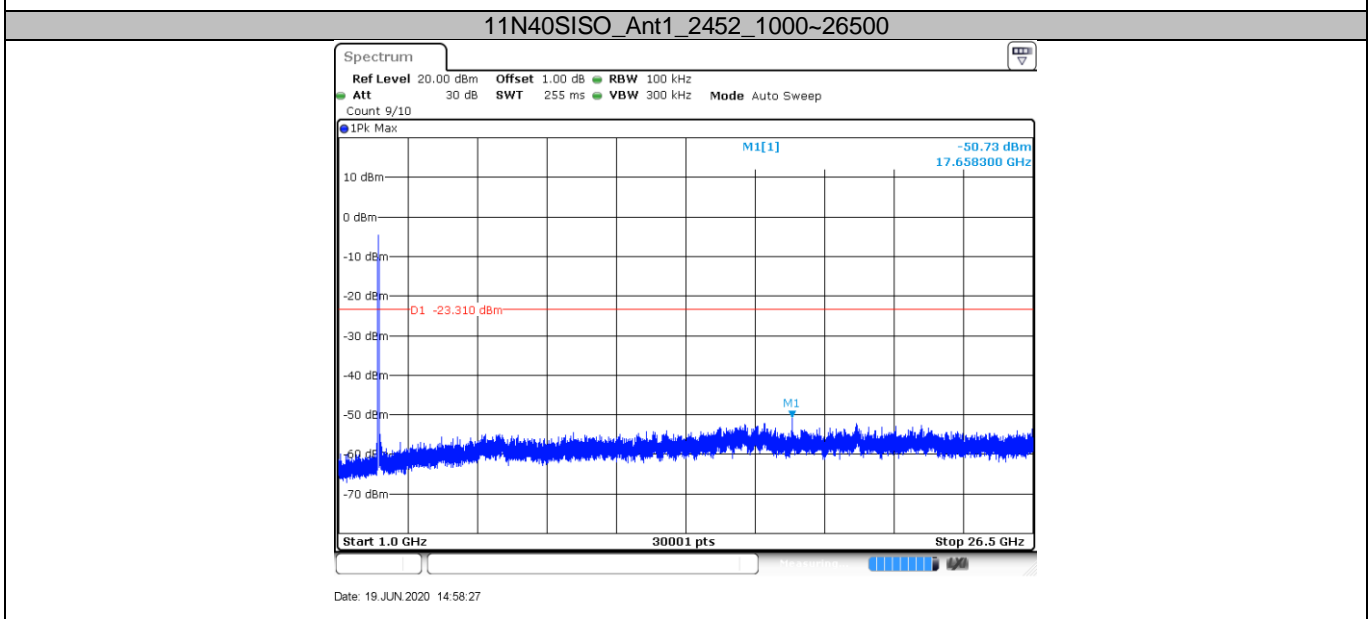
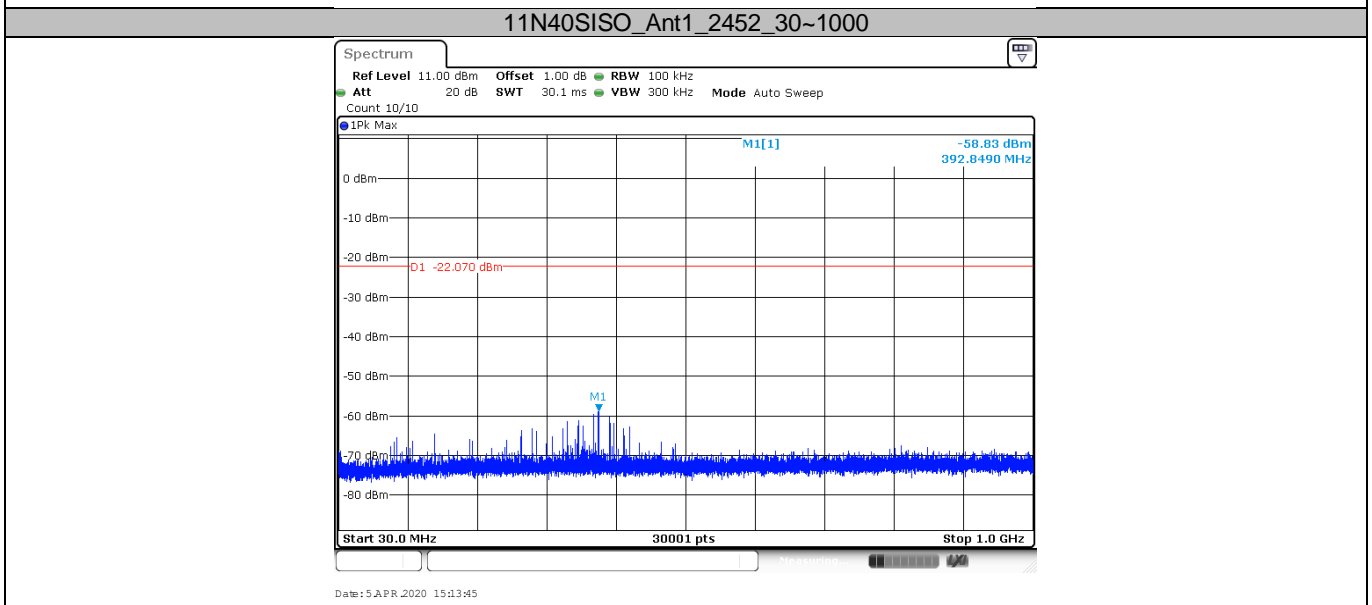
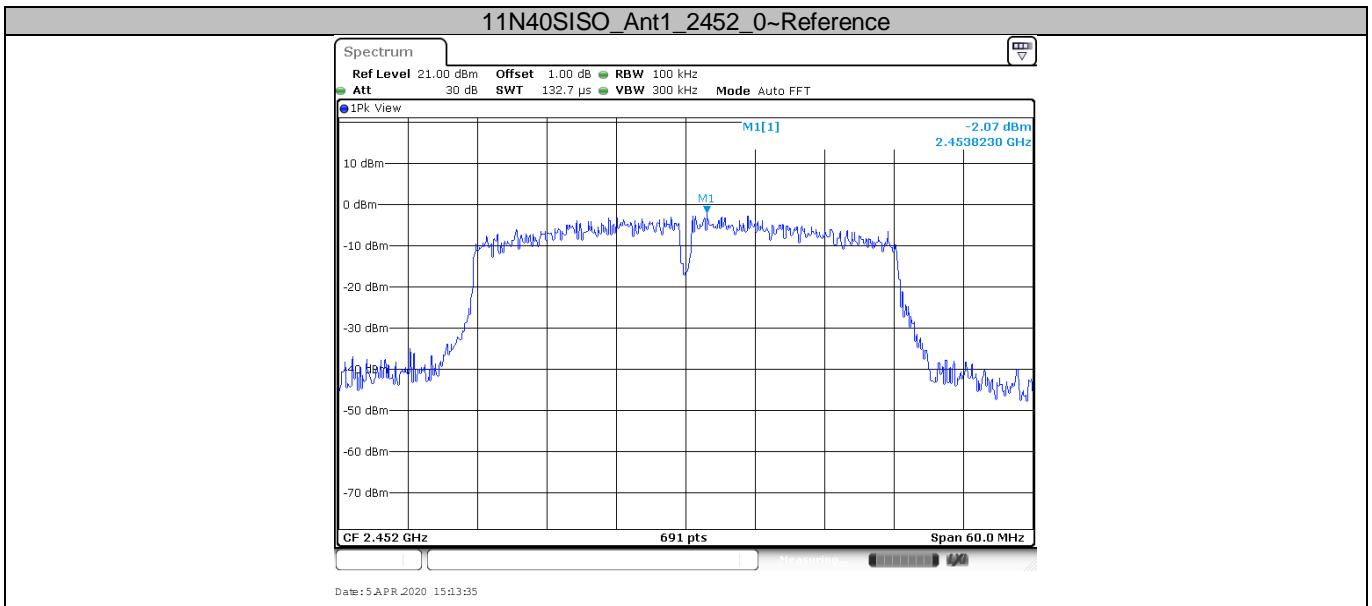

9.6 Band edge testing

Test Method

- 1 Use the following spectrum analyzer settings:
Span = wide enough to capture the peak level of the in-band emission and all spurious
RBW = 100 kHz, VBW ≥ RBW, Sweep = auto, Detector function = peak, Trace = max hold
- 2 Allow the trace to stabilize, use the peak and delta measurement to record the result.
- 3 The level displayed must comply with the limit specified in this Section. .
- 4 Repeat the test at the hopping off and hopping on mode, submit all the plots.

Limit:

According to §15.247(d), in any 100 kHz bandwidth outside the frequency bands in which the spread spectrum intentional radiator is operating, the radio frequency power that is produced by the intentional radiator shall be at least 20 dB below that in the 100 kHz bandwidth within the band that contains the highest level of the desired power, based on either an RF conducted or a radiated measurement, provided the transmitter demonstrates compliance with the peak conducted power limits. In addition, radiated emissions which fall in the restricted bands, as defined in §15.205(a), must also comply with the radiated emission limits specified in 15.209(a) (see Section 15.205(c)).

Frequency Range MHz	Limit (dBc)
30-25000	-20

Test result:

TestMode	Antenna	ChName	Channel(MHz)	RefLevel(dBm)	Result(dBm)	Limit(dBm)	Verdict
11B	Ant1	Low	2412	5.57	-38.54	<=-14.43	PASS
		High	2462	5.62	-50.76	<=-14.38	PASS
11G	Ant1	Low	2412	1.73	-31.68	<=-18.27	PASS
		High	2462	1.47	-37.72	<=-18.53	PASS
11N20SISO	Ant1	Low	2412	1.29	-32.15	<=-18.71	PASS
		High	2462	1.29	-47.46	<=-18.71	PASS
11N40SISO	Ant1	Low	2422	-3.13	-36.21	<=-23.13	PASS
		High	2452	-2.53	-44.14	<=-22.53	PASS

Band edge testing

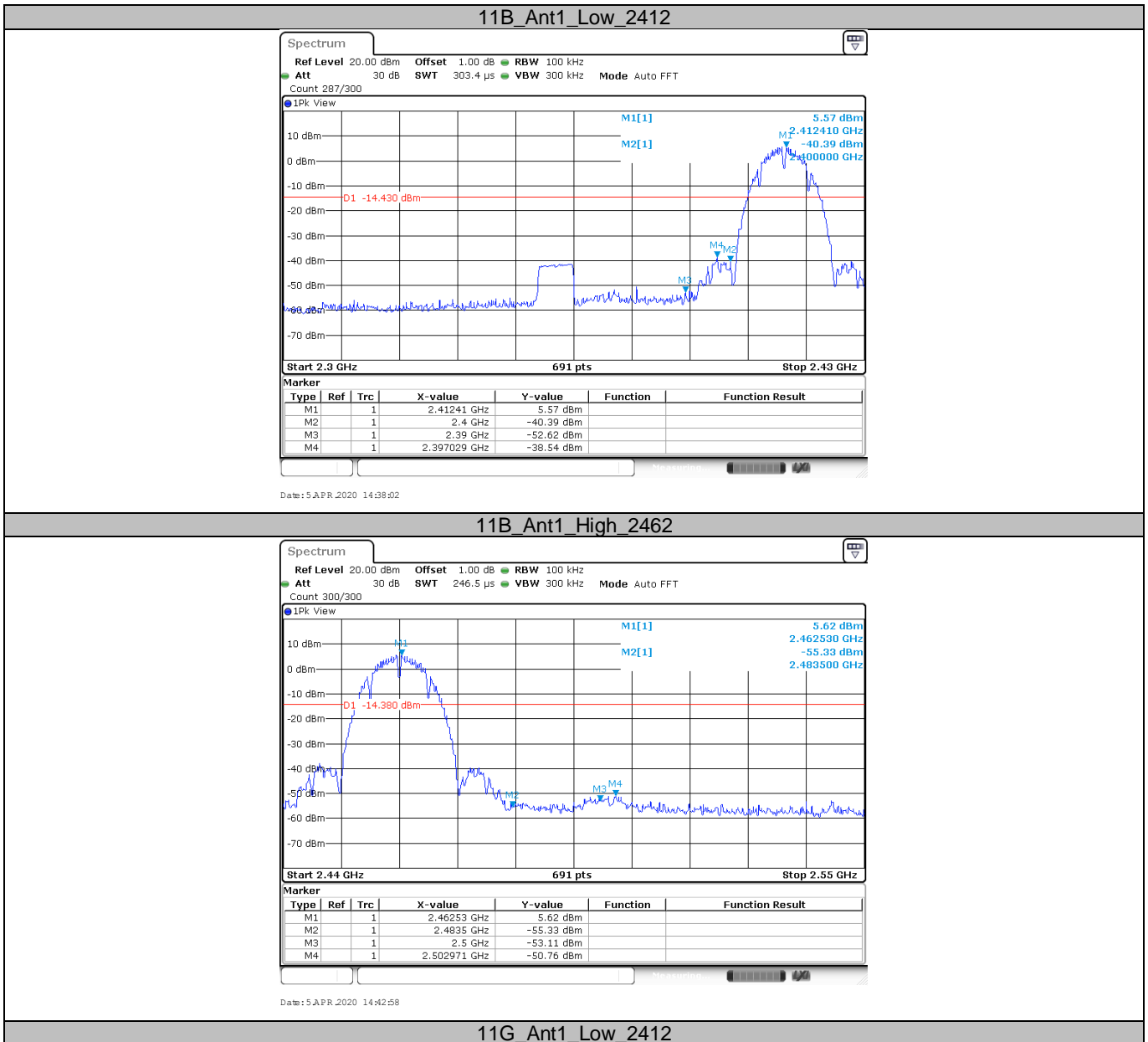

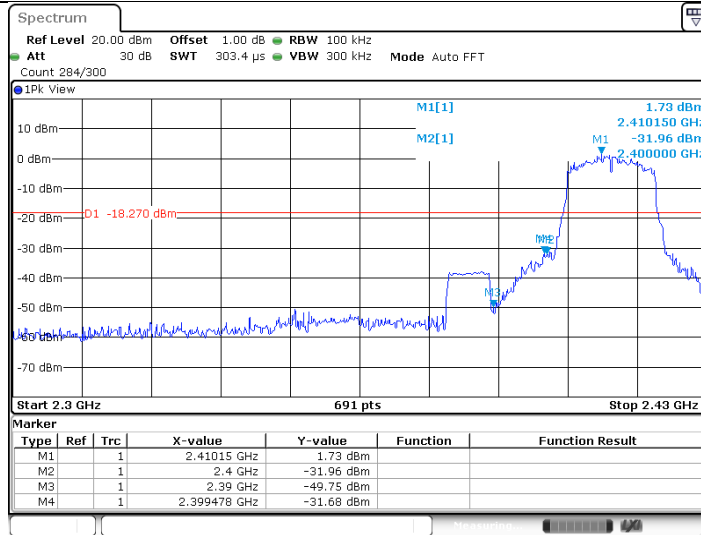

Date: 5 APR 2020 14:44:48

11G_Ant1_High_2462

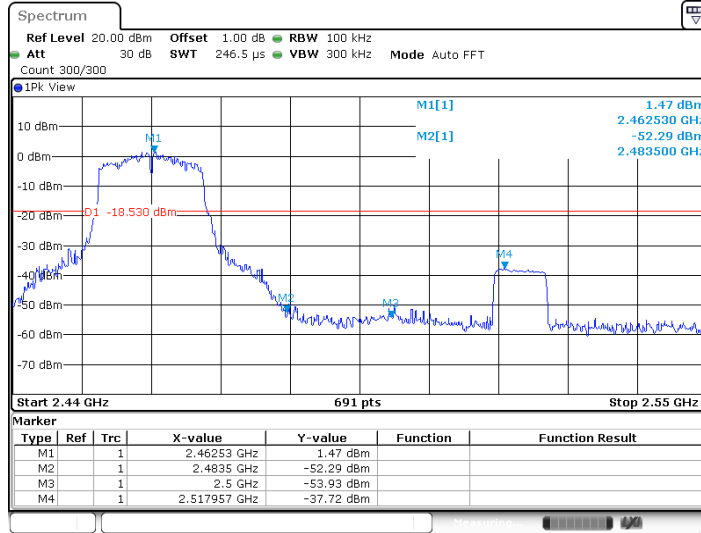

Date: 5 APR 2020 14:48:26

11N20SISO_Ant1_Low_2412

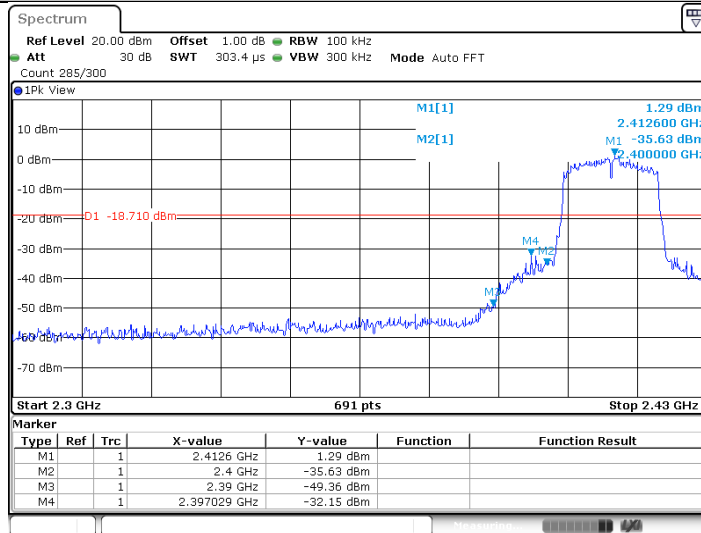

Date: 5 APR 2020 14:55:22

11N20SISO_Ant1_High_2462

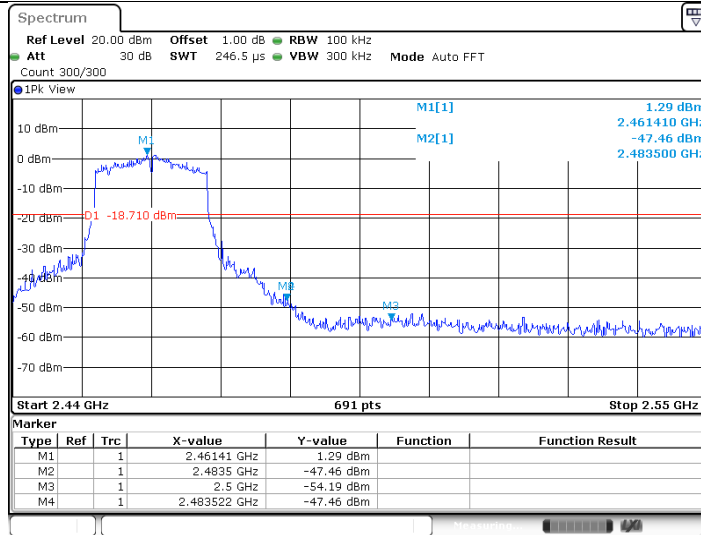

Date: 5 APR 2020 14:58:44

11N40SISO_Ant1_Low_2422

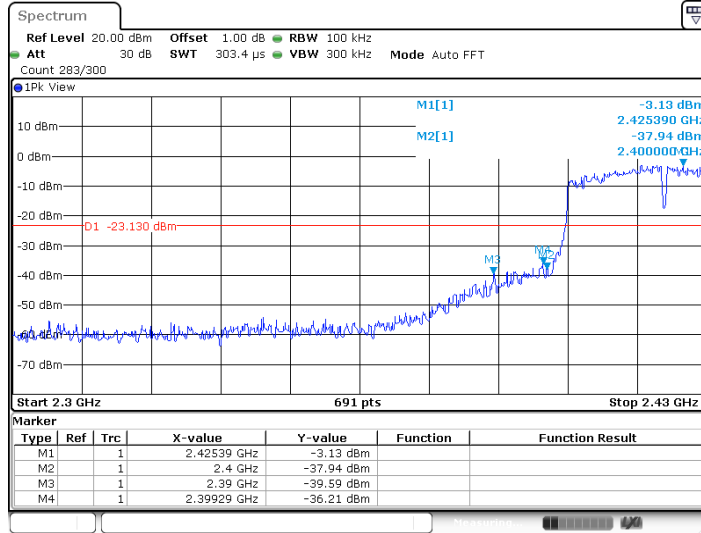

Date: 5 APR 2020 15:09:52

11N40SISO_Ant1_Low_2452

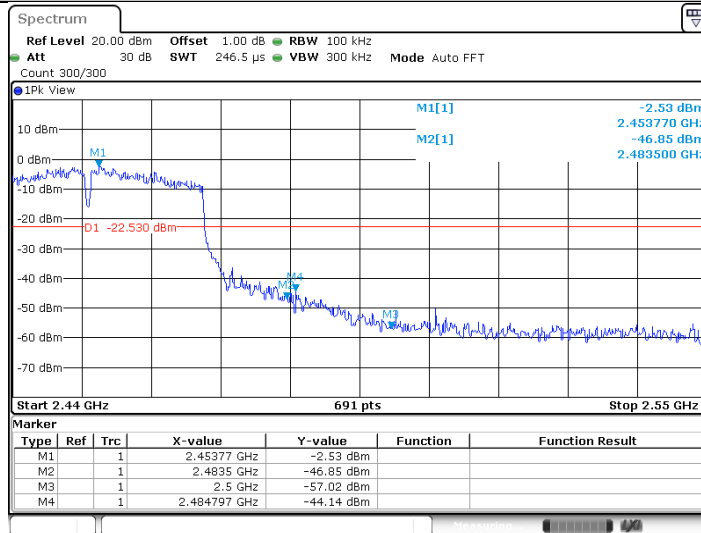

Date: 5 APR 2020 15:13:29

9.7 Spurious radiated emissions for transmitter

Test Method

1. The EUT was placed on a turn table which is 1.5m above ground plane for above 1GHz and 0.8m above ground for below 1GHz at 3 meter chamber room for test. The table was rotated 360 degrees to determine the position of the highest radiation.
2. The EUT was set 3 meters away from the interference – receiving antenna, which was mounted on the top of a variable – height antenna tower.
3. The height of antenna is varied from one meter to four meters above the ground to determine the maximum value of the field strength. Both horizontal and vertical polarizations of the antenna are set to make the measurement.
4. For each suspected emission, the EUT was arranged to its worst case and then the antenna was tuned to heights from 1 meter to 4 meters and the rotatable table was turned from 0 degrees to 360 degrees to find the maximum reading.
5. Use the following spectrum analyzer settings According to C63.10:

For Below 1GHz

Use the following spectrum analyzer settings:

Span = wide enough to capture the peak level of the in-band emission and all spurious
RBW = 100 KHz to 120KHz, VBW ≥ RBW for peak measurement, Sweep = auto, Detector function = peak, Trace = max hold.

For Peak unwanted emissions Above 1GHz:

Span = wide enough to capture the peak level of the in-band emission and all spurious
RBW = 1MHz, VBW ≥ RBW for peak measurement, Sweep = auto, Detector function = peak, Trace = max hold.

Procedures for average unwanted emissions measurements above 1000 MHz

- a) RBW = 1 MHz.
- b) $VBW \geq [3 \times RBW]$.
- c) Detector = RMS (power averaging), if $[\text{span} / (\# \text{ of points in sweep})] \leq RBW / 2$.
Satisfying this condition can require increasing the number of points in the sweep or reducing the span. If the condition is not satisfied, then the detector mode shall be set to peak.
- d) Averaging type = power (i.e., rms) (As an alternative, the detector and averaging type may be set for linear voltage averaging. Some instruments require linear display mode to use linear voltage averaging. Log or dB averaging shall not be used.)
- e) Sweep time = auto.
- f) Perform a trace average of at least 100 traces if the transmission is continuous. If the transmission is not continuous, then the number of traces shall be increased by a factor of $1 / D$, where D is the duty cycle. For example, with 50% duty cycle, at least 200 traces shall be averaged. (If a specific emission is demonstrated to be continuous—i.e., 100% duty cycle—then rather than turning ON and OFF with the transmit cycle, at least 100 traces shall be averaged.)
- g) If tests are performed with the EUT transmitting at a duty cycle less than 98%, then a correction factor shall be added to the measurement results prior to comparing with the emission limit, to compute the emission level that would have been measured had the test been performed at 100% duty cycle. The correction factor is computed as follows:
 - 1) If power averaging (rms) mode was used in the preceding step e), then the correction factor is $[10 \log (1 / D)]$, where D is the duty cycle. For example, if the transmit duty cycle was 50%, then 3 dB shall be added to the measured emission levels.

2) If linear voltage averaging mode was used in the preceding step e), then the correction factor is $[20 \log (1 / D)]$, where D is the duty cycle. For example, if the transmit duty cycle was 50%, then 6 dB shall be added to the measured emission levels.

3) If a specific emission is demonstrated to be continuous (100% duty cycle) rather than turning ON and OFF with the transmit cycle, then no duty cycle correction is required for that emission.

Limit

The radio emission outside the operating frequency band shall be at least 20 dB below that in the 100 kHz bandwidth within the band that contains the highest level of the desired power. Radiated emissions which fall in the restricted bands, as defined in section 15.205, must comply with the radiated emission limits specified in section 15.209.

Frequency MHz	Field Strength uV/m	Field Strength dBµV/m	Detector
30-88	100	40	QP
88-216	150	43.5	QP
216-960	200	46	QP
960-1000	500	54	QP
Above 1000	500	54	AV
Above 1000	5000	74	PK

Spurious radiated emissions for transmitter

According to C63.10, if the peak (or quasi-peak) measured value complies with the average limit, it is unnecessary to perform an average measurement, so AV emission value did not show in below table if the peak value complies with average limit.

Transmitting spurious emission test result as below:

Below 1G:

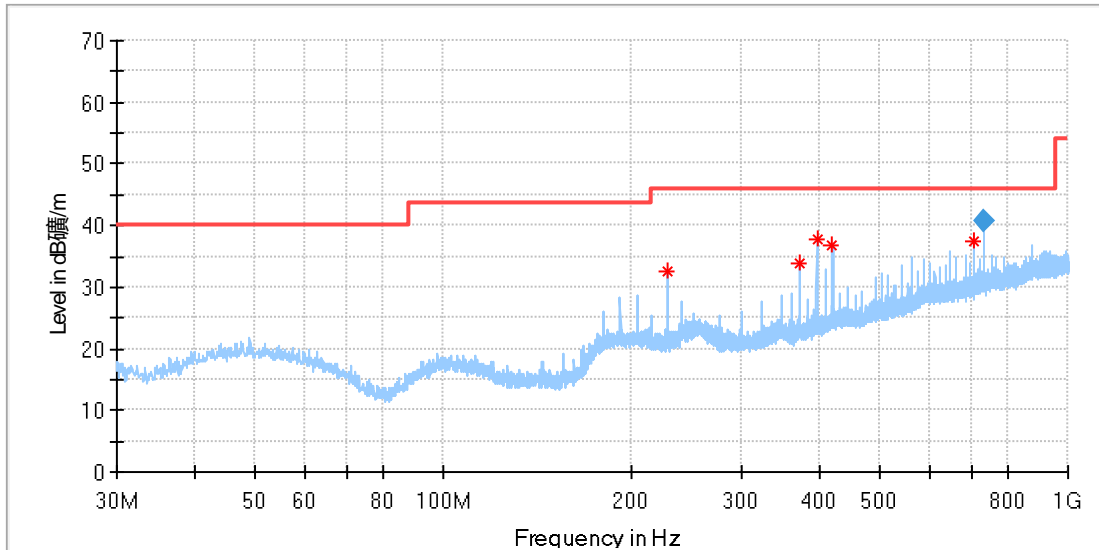

Frequency (MHz)	MaxPeak (dBµV/m)	Limit (dBµV/m)	Margin (dB)	Height (cm)	Pol	Azimuth (deg)	Corr. (dB/m)
228.001250	32.68	46.00	13.32	100.0	H	351.0	17
372.046250	33.88	46.00	12.12	100.0	H	145.0	20
395.993125	37.65	46.00	8.35	100.0	H	135.0	21
420.000625	36.68	46.00	9.32	100.0	H	145.0	22
708.090625	37.39	46.00	8.61	100.0	H	0.0	27
732.098125	40.56	46.00	5.44	100.0	H	351.0	27
Frequency (MHz)	QuasiPeak (dBµV/m)	Limit (dBµV/m)	Margin (dB)	Height (cm)	Pol	Azimuth (deg)	Corr. (dB/m)
732.098125	40.56	39.93	6.07	100.0	H	351.0	27

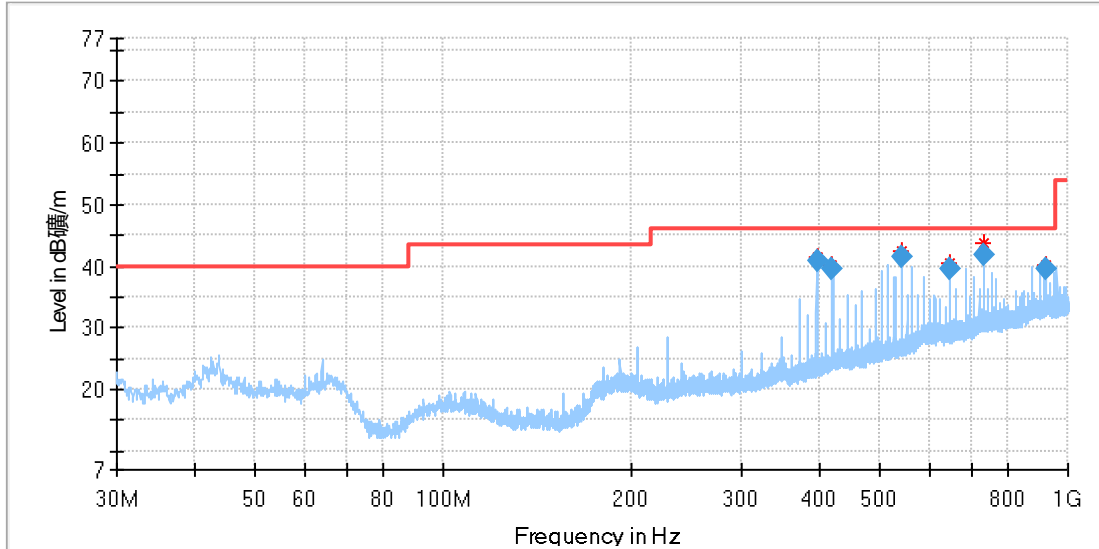

Frequency (MHz)	MaxPeak (dBµV/m)	Limit (dBµV/m)	Margin (dB)	Height (cm)	Pol	Azimuth (deg)	Corr. (dB/m)
396.053750	41.45	46.00	4.55	100.0	V	333.0	21
420.000625	40.22	46.00	5.78	100.0	V	278.0	22
540.056563	42.41	46.00	3.59	115.0	V	337.0	24
648.071875	40.42	46.00	5.58	100.0	V	0.0	26
732.077188	43.76	46.00	2.24	100.0	V	214.0	27
924.097500	40.31	46.00	5.69	100.0	V	5.0	30
Frequency (MHz)	QuasiPeak (dBµV/m)	Limit (dBµV/m)	Margin (dB)	Height (cm)	Pol	Azimuth (deg)	Corr. (dB/m)
396.053750	41.02	46.00	4.98	100.0	V	333.0	21
420.000625	39.69	46.00	6.31	100.0	V	278.0	22
540.056563	41.47	46.00	4.53	115.0	V	337.0	24
648.071875	39.51	46.00	6.49	100.0	V	0.0	26
732.077188	41.80	46.00	4.20	100.0	V	214.0	27
924.097500	39.68	46.00	6.32	100.0	V	5.0	30

802.11B mode 2412MHz Test Result

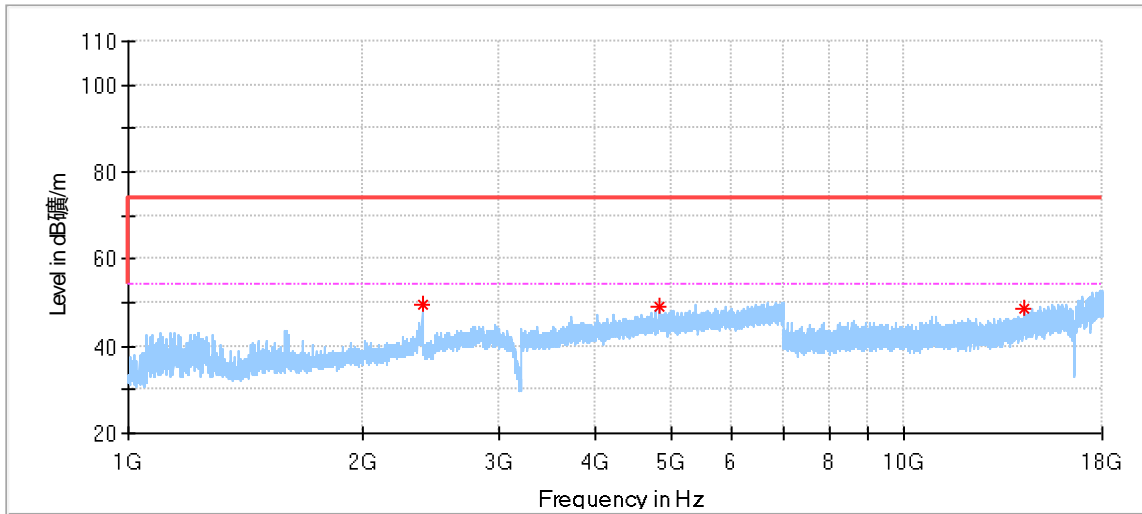

Frequency (MHz)	MaxPeak (dBµV/m)	Limit (dBµV/m)	Margin (dB)	Height (cm)	Pol	Azimuth (deg)	Corr. (dB/m)
2390.500000	49.64	74.00	24.36	150.0	H	129.0	-6.8
4824.000000	49.22	74.00	24.78	150.0	H	93.0	2.2
14260.500000	48.62	74.00	25.38	150.0	H	40.0	10.8

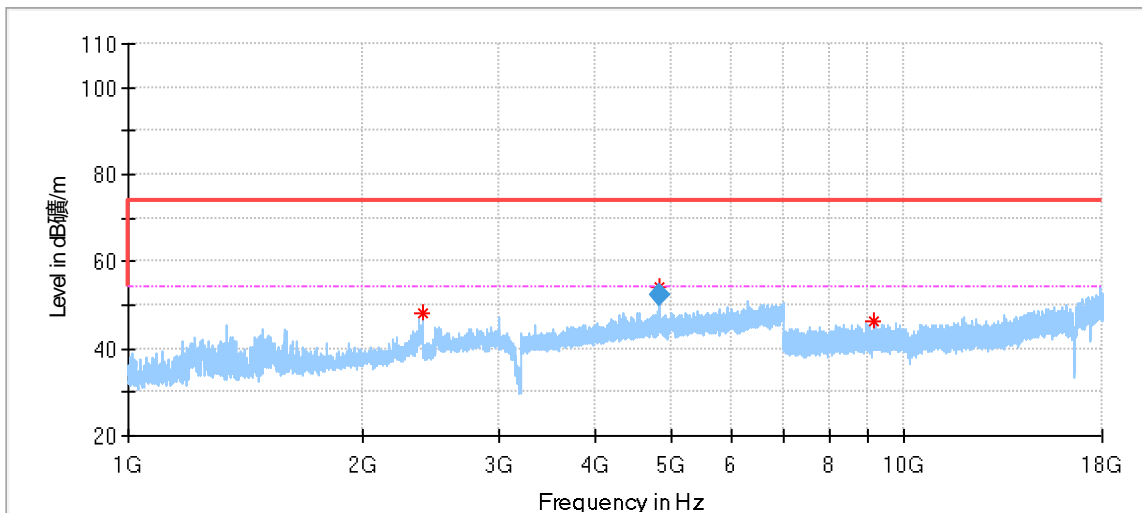

Frequency (MHz)	MaxPeak (dBµV/m)	Limit (dBµV/m)	Margin (dB)	Height (cm)	Pol	Azimuth (deg)	Corr. (dB/m)
2394.000000	47.98	74.00	26.02	150.0	V	90.0	-6.8
4824.000000	54.03	74.00	19.97	150.0	V	5.0	2.2
9134.500000	46.09	74.00	27.91	150.0	V	116.0	7.4
Frequency (MHz)	Average (dBµV/m)	Limit (dBµV/m)	Margin (dB)	Height (cm)	Pol	Azimuth (deg)	Corr. (dB/m)
4824.000000	53.33	54.00	0.67	150.0	V	5.0	2.2

802.11B mode 2437MHz Test Result

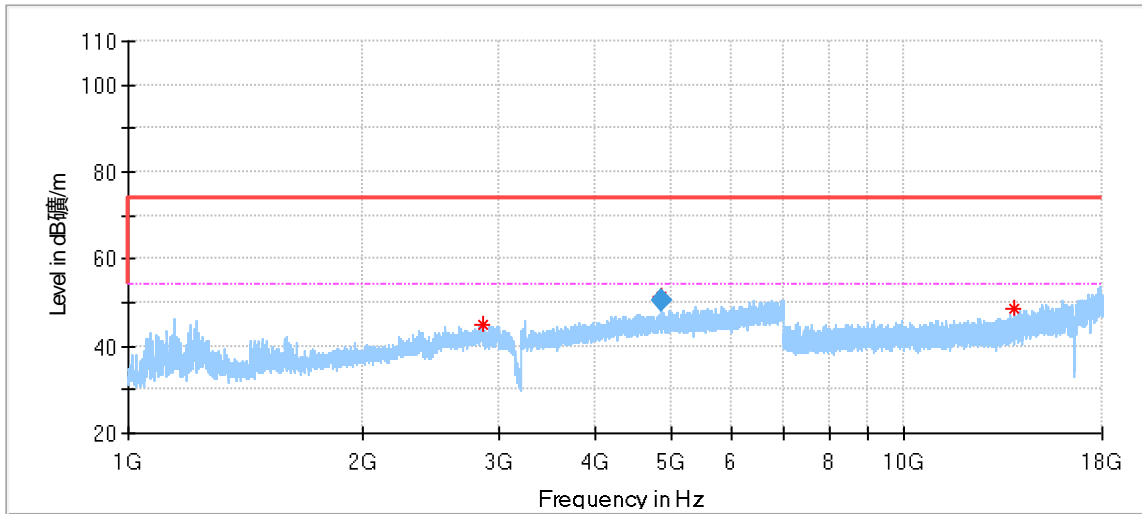

Frequency (MHz)	MaxPeak (dBµV/m)	Limit (dBµV/m)	Margin (dB)	Height (cm)	Pol	Azimuth (deg)	Corr. (dB/m)
2858.000000	45.07	74.00	28.93	150.0	H	99.0	-4.8
4874.000000	51.58	74.00	22.42	150.0	H	0.0	2.3
13845.000000	48.53	74.00	25.47	150.0	H	197.0	9.9

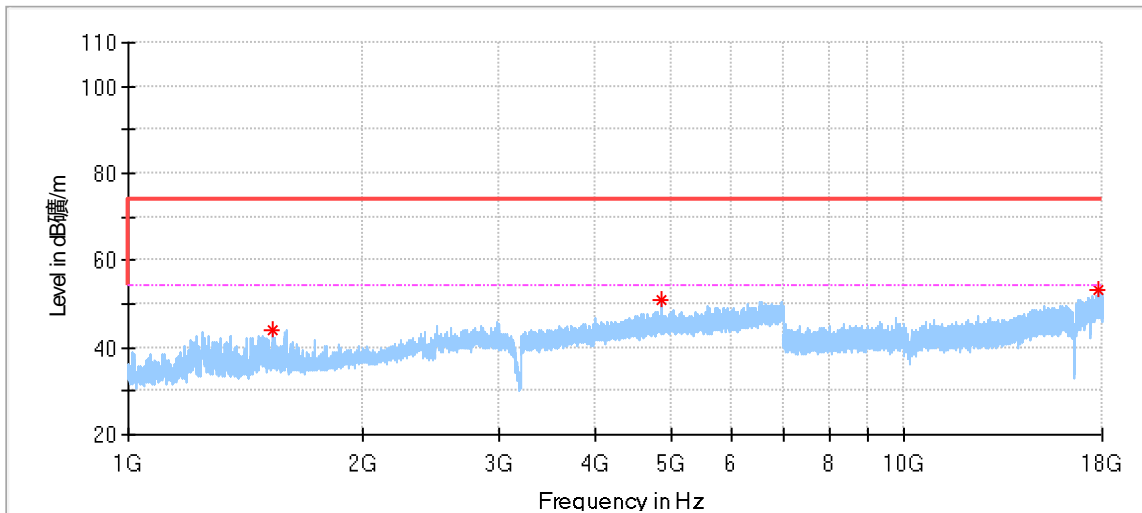

Frequency (MHz)	MaxPeak (dBµV/m)	Limit (dBµV/m)	Margin (dB)	Height (cm)	Pol	Azimuth (deg)	Corr. (dB/m)
1530.500000	44.19	74.00	29.81	150.0	V	261.0	-11.0
4874.000000	50.82	74.00	23.18	150.0	V	341.0	2.3
17745.500000	53.29	74.00	20.71	150.0	V	358.0	19.3

802.11B mode 2462MHz Test Result

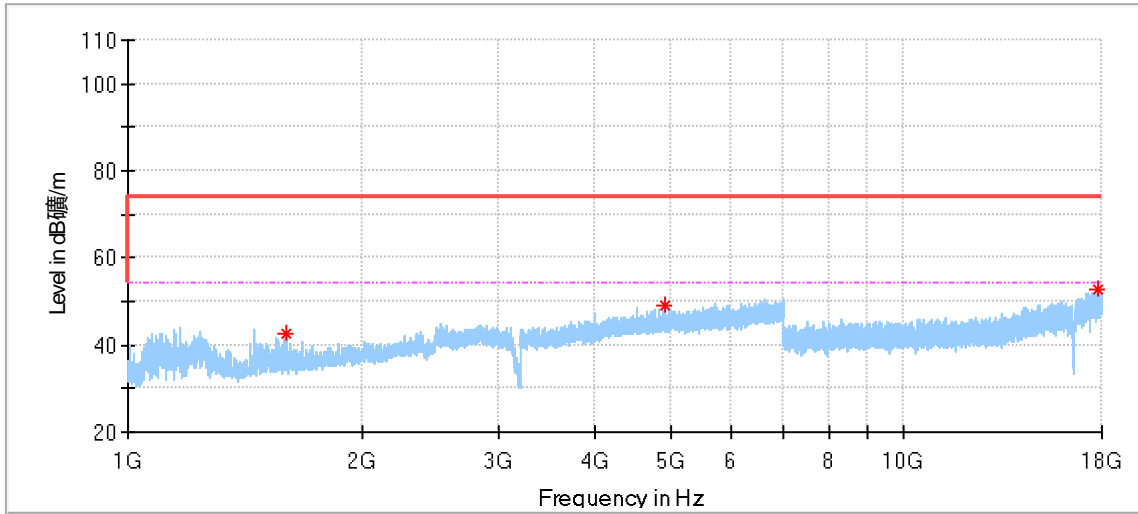

Frequency (MHz)	MaxPeak (dBμV/m)	Limit (dBμV/m)	Margin (dB)	Height (cm)	Pol	Azimuth (deg)	Corr. (dB/m)
1597.000000	42.51	74.00	31.49	150.0	H	24.0	-10.7
4924.000000	49.12	74.00	24.88	150.0	H	7.0	2.2
17749.500000	52.79	74.00	21.21	150.0	H	200.0	19.2

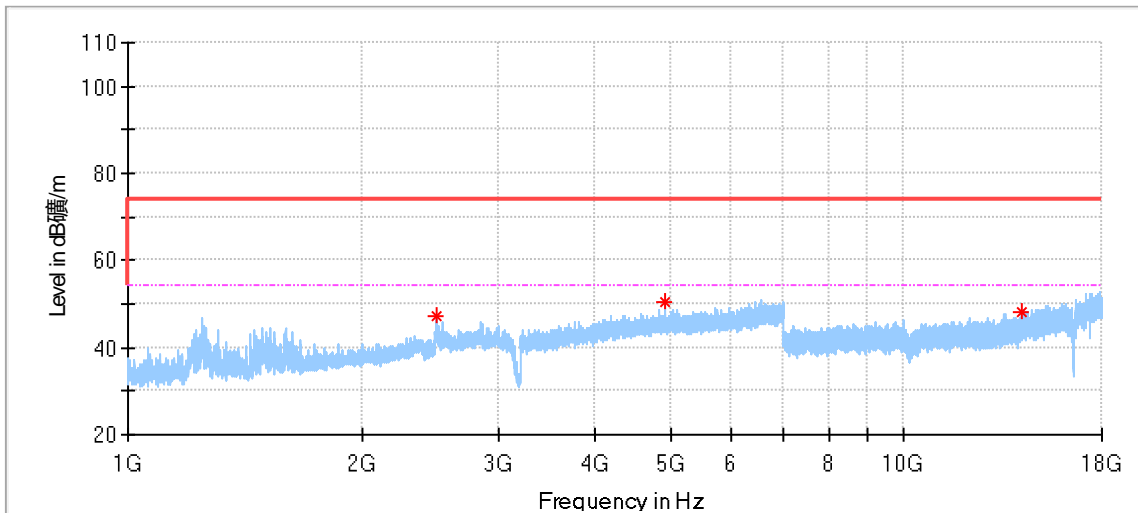

Frequency (MHz)	MaxPeak (dBμV/m)	Limit (dBμV/m)	Margin (dB)	Height (cm)	Pol	Azimuth (deg)	Corr. (dB/m)
2498.500000	47.07	74.00	26.93	150.0	V	77.0	-6.3
4924.000000	50.51	74.00	23.49	150.0	V	245.0	2.2
14214.000000	48.26	74.00	25.74	150.0	V	244.0	10.8

802.11G mode 2412MHz Test Result

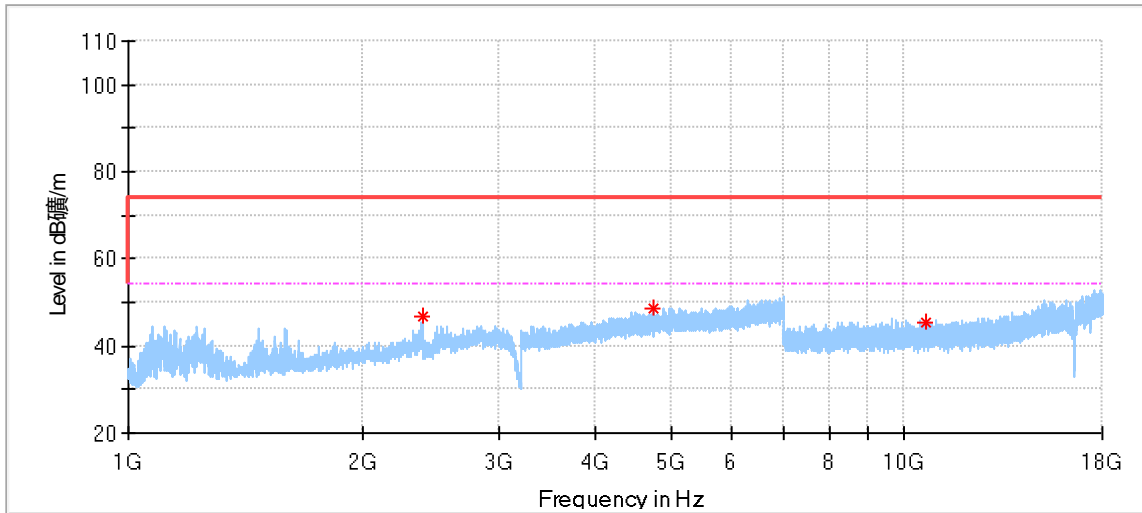

Frequency (MHz)	MaxPeak (dBµV/m)	Limit (dBµV/m)	Margin (dB)	Height (cm)	Pol	Azimuth (deg)	Corr. (dB/m)
2393.500000	47.00	74.00	27.00	150.0	H	293.0	-6.8
4760.500000	48.69	74.00	25.31	150.0	H	327.0	2.5
10692.500000	45.55	74.00	28.45	150.0	H	321.0	7.7

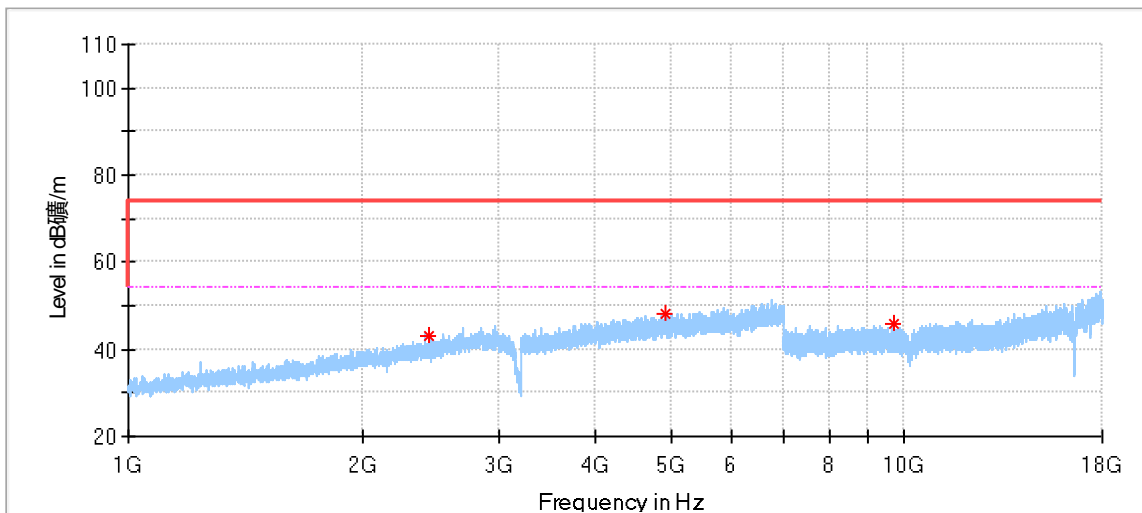

Frequency (MHz)	MaxPeak (dBµV/m)	Limit (dBµV/m)	Margin (dB)	Height (cm)	Pol	Azimuth (deg)	Corr. (dB/m)
2434.500000	42.97	74.00	31.03	150.0	V	342.0	-6.6
4931.500000	48.08	74.00	25.92	150.0	V	331.0	2.0
9722.000000	45.83	74.00	28.17	150.0	V	203.0	7.8

802.11G mode 2437MHz Test Result

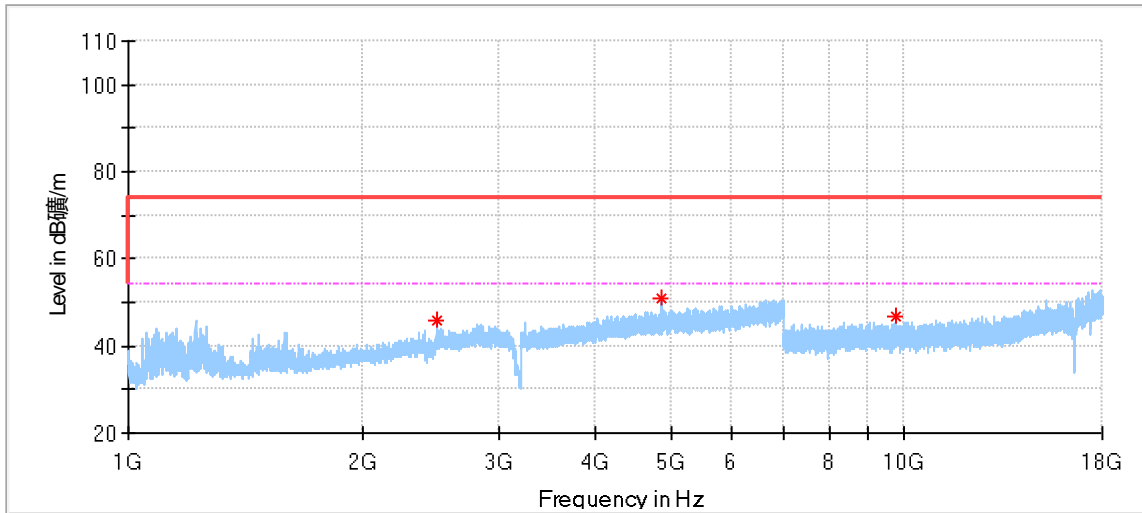

Frequency (MHz)	MaxPeak (dBµV/m)	Limit (dBµV/m)	Margin (dB)	Height (cm)	Pol	Azimuth (deg)	Corr. (dB/m)
2493.000000	45.95	74.00	28.05	150.0	H	142.0	-6.3
4874.500000	50.97	74.00	23.03	150.0	H	49.0	2.3
9729.000000	46.93	74.00	27.07	150.0	H	172.0	7.9

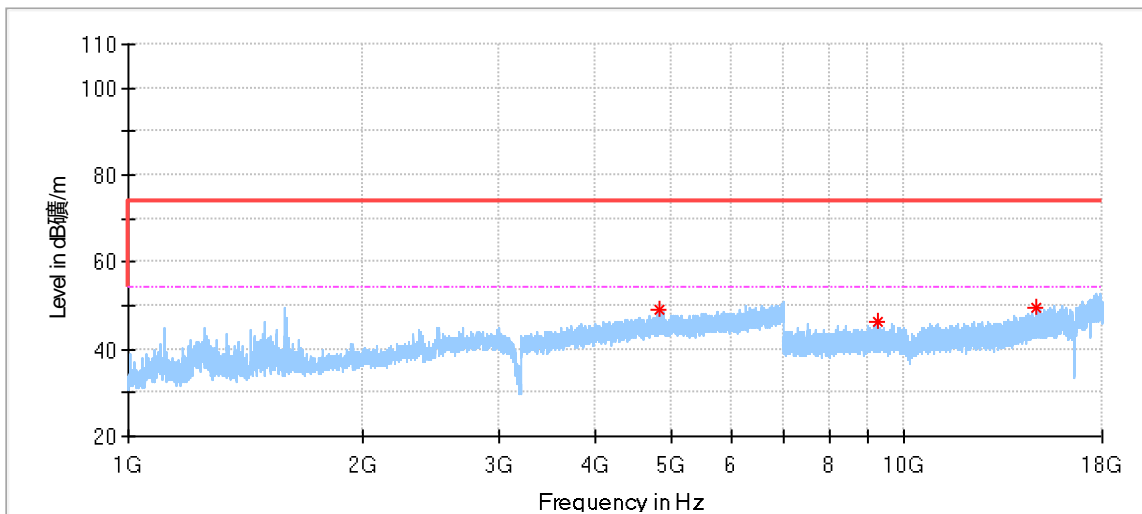

Frequency (MHz)	MaxPeak (dBµV/m)	Limit (dBµV/m)	Margin (dB)	Height (cm)	Pol	Azimuth (deg)	Corr. (dB/m)
4847.500000	49.00	74.00	25.00	150.0	V	178.0	2.2
9260.000000	46.28	74.00	27.72	150.0	V	208.0	7.5
14755.000000	49.74	74.00	24.26	150.0	V	51.0	11.9

802.11G mode 2462MHz Test Result

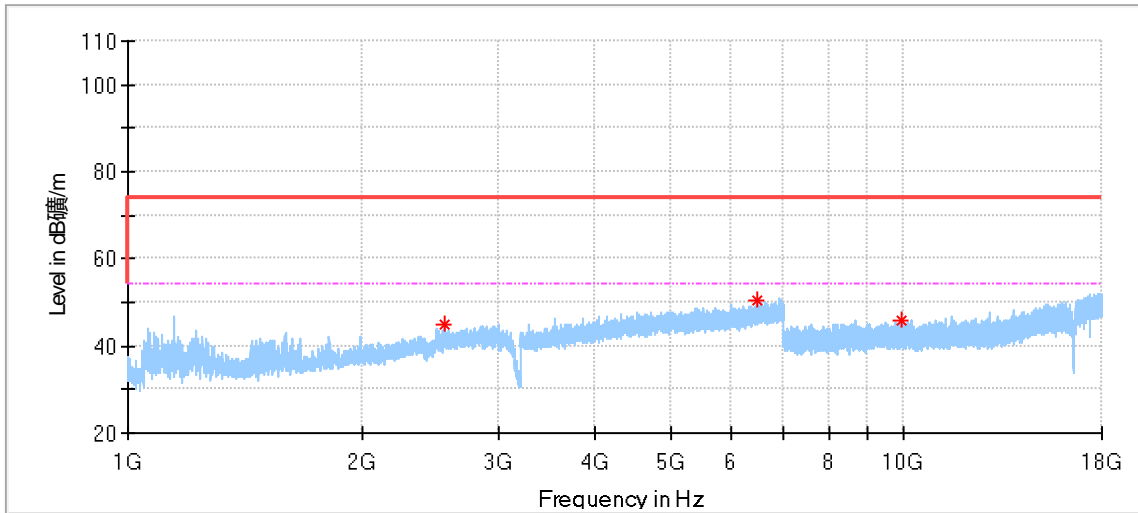

Frequency (MHz)	MaxPeak (dBµV/m)	Limit (dBµV/m)	Margin (dB)	Height (cm)	Pol	Azimuth (deg)	Corr. (dB/m)
2558.000000	44.75	74.00	29.25	150.0	H	142.0	-6.1
6485.000000	50.44	74.00	23.56	150.0	H	16.0	5.7
9909.500000	45.93	74.00	28.07	150.0	H	119.0	7.9

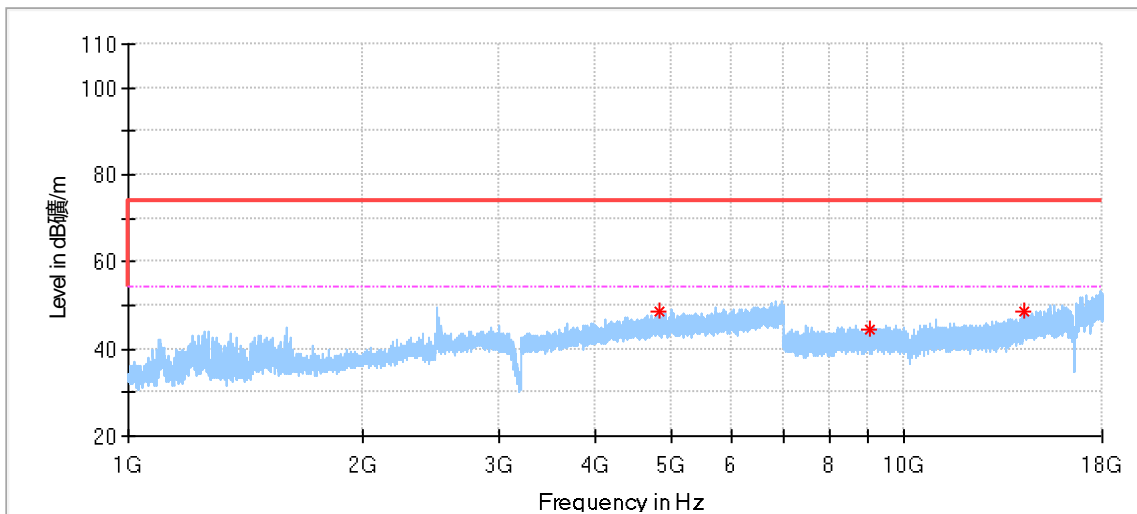

Frequency (MHz)	MaxPeak (dBµV/m)	Limit (dBµV/m)	Margin (dB)	Height (cm)	Pol	Azimuth (deg)	Corr. (dB/m)
4829.500000	48.71	74.00	25.29	150.0	V	146.0	2.1
9005.000000	44.55	74.00	29.45	150.0	V	333.0	7.4
14245.000000	48.45	74.00	25.55	150.0	V	144.0	10.9

802.11N20 mode 2412MHz Test Result

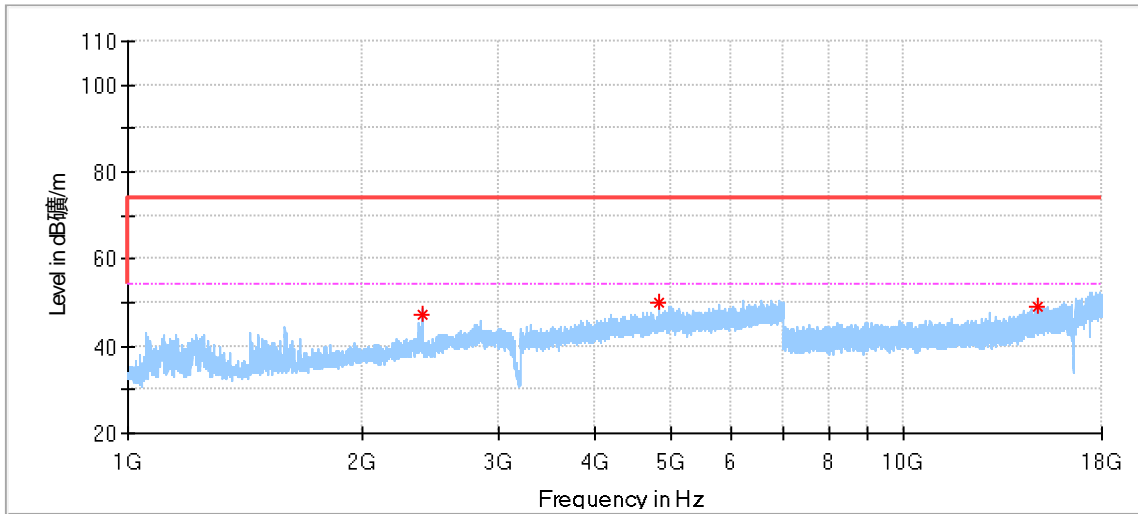

Frequency (MHz)	MaxPeak (dBµV/m)	Limit (dBµV/m)	Margin (dB)	Height (cm)	Pol	Azimuth (deg)	Corr. (dB/m)
2391.000000	47.33	74.00	26.67	150.0	H	65.0	-6.8
4847.000000	49.94	74.00	24.06	150.0	H	219.0	2.2
14852.500000	49.04	74.00	24.96	150.0	H	117.0	12.5

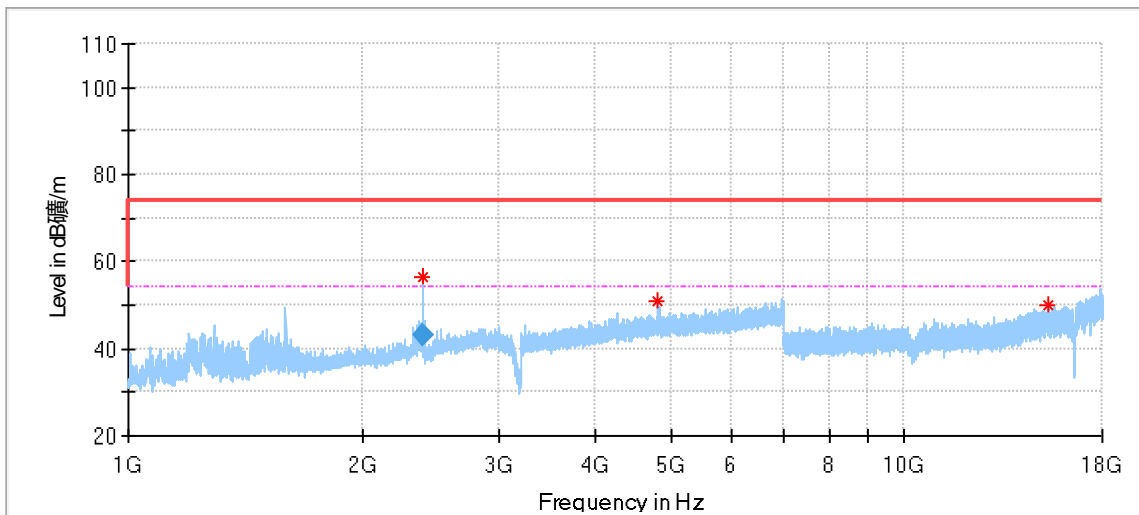

Frequency (MHz)	MaxPeak (dBµV/m)	Limit (dBµV/m)	Margin (dB)	Height (cm)	Pol	Azimuth (deg)	Corr. (dB/m)
2391.500000	56.60	74.00	17.40	150.0	V	109.0	-6.8
4820.500000	51.05	74.00	22.95	150.0	V	96.0	2.3
15344.000000	50.21	74.00	23.79	150.0	V	104.0	12.9
Frequency (MHz)	Average (dBµV/m)	Limit (dBµV/m)	Margin (dB)	Height (cm)	Pol	Azimuth (deg)	Corr. (dB/m)
2391.500000	43.01	54.00	10.99	150.0	V	109.0	-6.8

802.11N20 mode 2437MHz Test Result

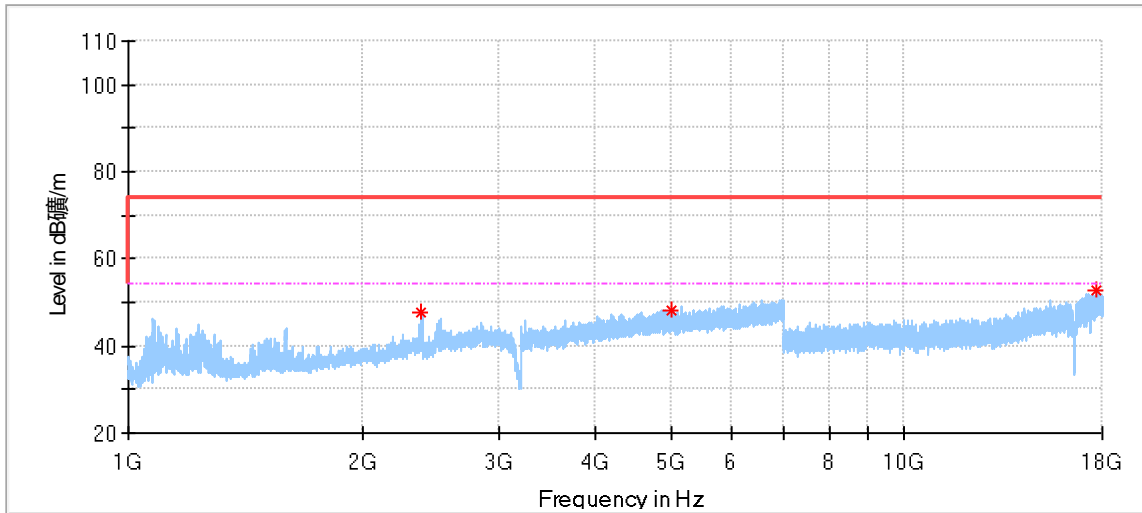

Frequency (MHz)	MaxPeak (dBµV/m)	Limit (dBµV/m)	Margin (dB)	Height (cm)	Pol	Azimuth (deg)	Corr. (dB/m)
2389.000000	47.70	74.00	26.30	150.0	H	50.0	-6.8
5023.000000	48.36	74.00	25.64	150.0	H	320.0	2.9
17687.500000	52.75	74.00	21.25	150.0	H	167.0	18.9

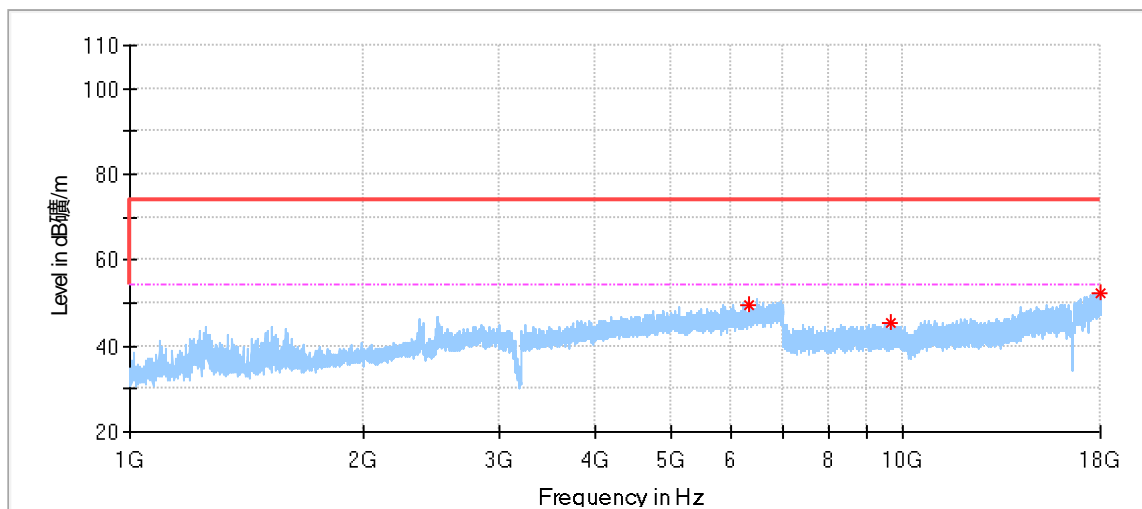

Frequency (MHz)	MaxPeak (dBµV/m)	Limit (dBµV/m)	Margin (dB)	Height (cm)	Pol	Azimuth (deg)	Corr. (dB/m)
6335.500000	49.67	74.00	24.33	150.0	V	7.0	5.3
9658.000000	45.48	74.00	28.52	150.0	V	168.0	7.7
17962.000000	52.44	74.00	21.56	150.0	V	238.0	19.1

802.11N20 mode 2462MHz Test Result

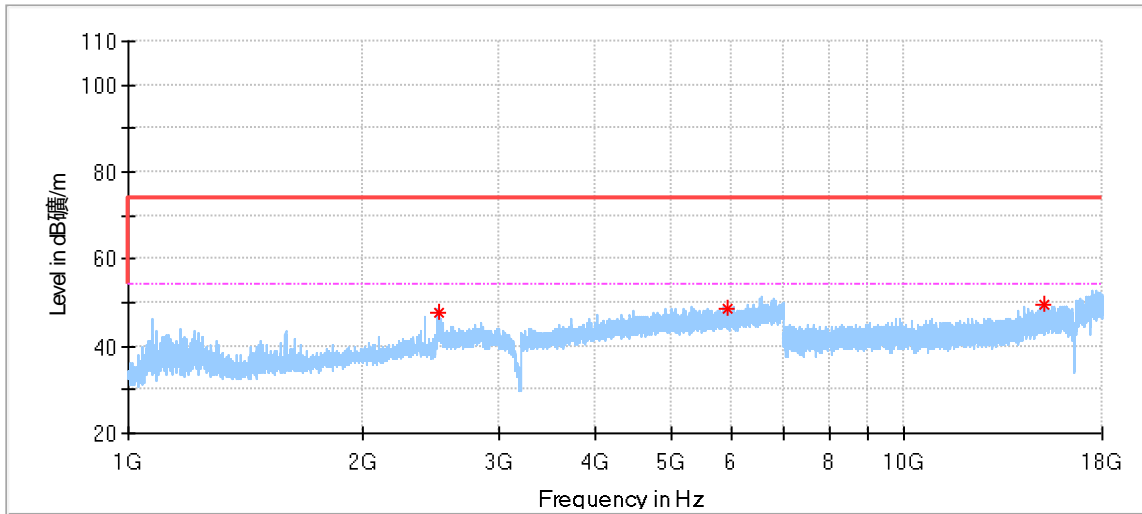

Frequency (MHz)	MaxPeak (dBµV/m)	Limit (dBµV/m)	Margin (dB)	Height (cm)	Pol	Azimuth (deg)	Corr. (dB/m)
2512.000000	47.85	74.00	26.15	150.0	H	49.0	-6.2
5934.000000	48.84	74.00	25.16	150.0	H	258.0	3.5
15180.500000	49.64	74.00	24.36	150.0	H	71.0	13.0

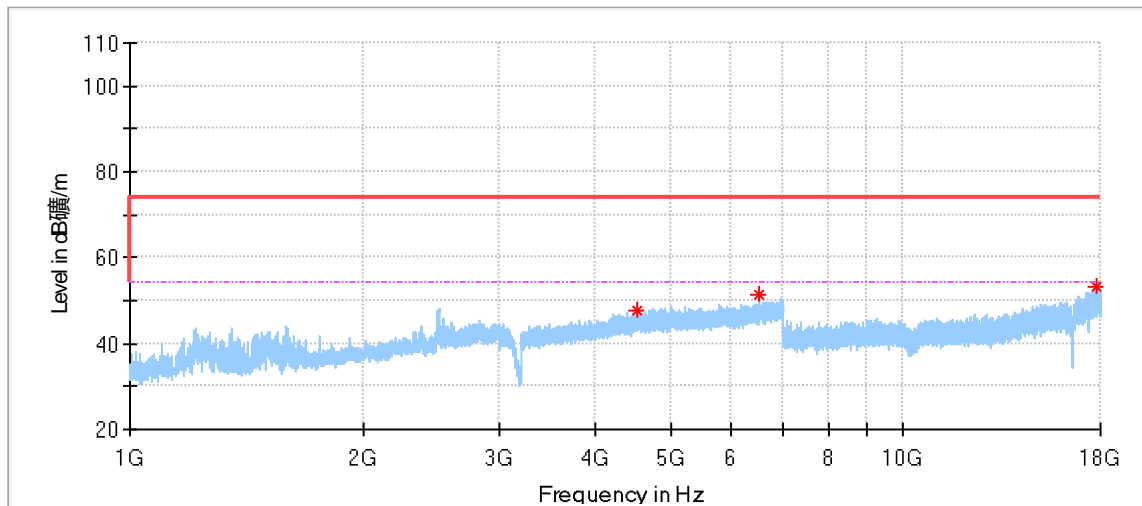

Frequency (MHz)	MaxPeak (dBµV/m)	Limit (dBµV/m)	Margin (dB)	Height (cm)	Pol	Azimuth (deg)	Corr. (dB/m)
4521.000000	47.69	74.00	26.31	150.0	V	314.0	2.6
6499.000000	51.32	74.00	22.68	150.0	V	0.0	5.8
17769.500000	53.21	74.00	20.79	150.0	V	206.0	19.1

802.11N40 mode 2412MHz Test Result

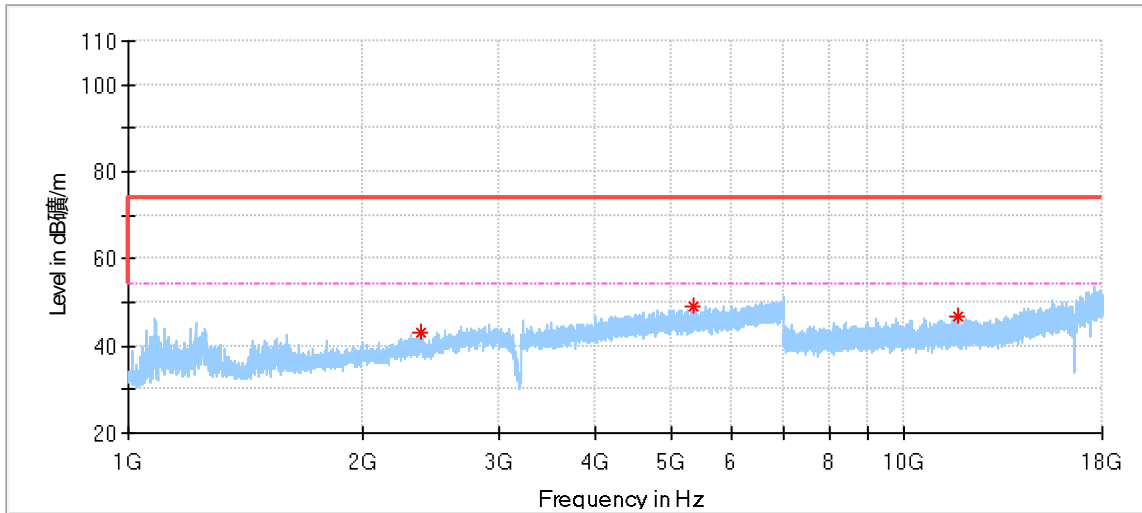

Frequency (MHz)	MaxPeak (dBµV/m)	Limit (dBµV/m)	Margin (dB)	Height (cm)	Pol	Azimuth (deg)	Corr. (dB/m)
2389.000000	43.24	74.00	30.76	150.0	H	138.0	-6.8
5361.000000	49.01	74.00	24.99	150.0	H	236.0	2.6
11729.500000	46.59	74.00	27.41	150.0	H	200.0	8.0

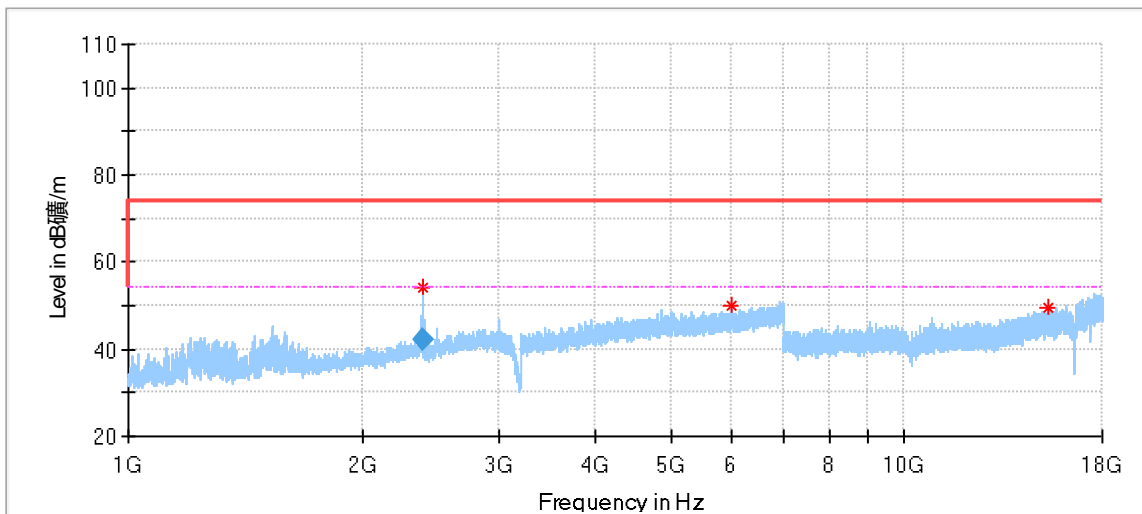

Frequency (MHz)	MaxPeak (dBµV/m)	Limit (dBµV/m)	Margin (dB)	Height (cm)	Pol	Azimuth (deg)	Corr. (dB/m)
2391.500000	54.33	74.00	19.67	150.0	V	261.0	-6.8
5985.500000	50.06	74.00	23.94	150.0	V	135.0	4.1
15352.500000	49.46	74.00	24.54	150.0	V	133.0	13.0
Frequency (MHz)	Average (dBµV/m)	Limit (dBµV/m)	Margin (dB)	Height (cm)	Pol	Azimuth (deg)	Corr. (dB/m)
2391.500000	42.10	54.00	11.90	150.0	V	261.0	-6.8

802.11N40 mode 2437MHz Test Result

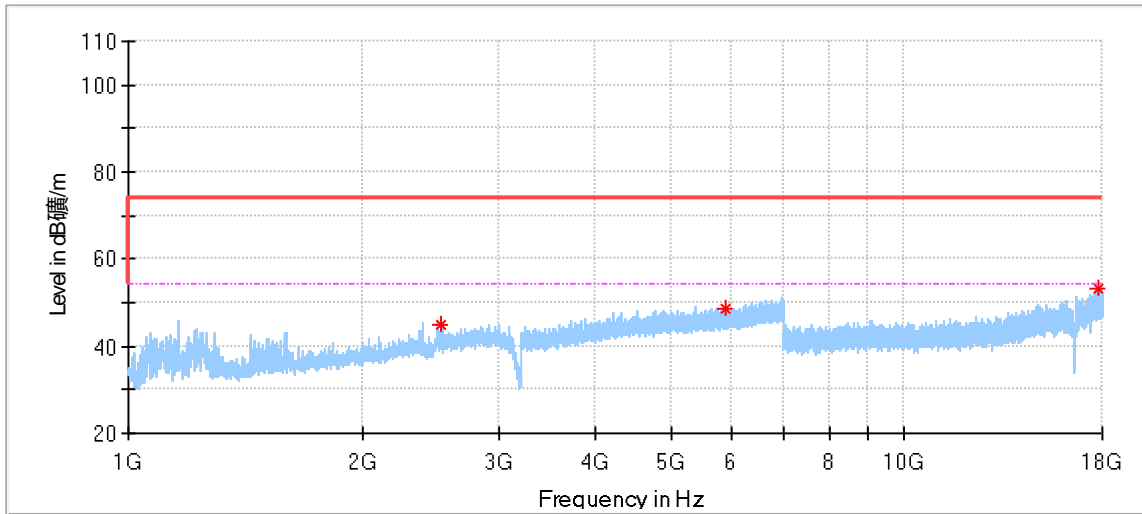

Frequency (MHz)	MaxPeak (dBµV/m)	Limit (dBµV/m)	Margin (dB)	Height (cm)	Pol	Azimuth (deg)	Corr. (dB/m)
2528.000000	45.10	74.00	28.90	150.0	H	15.0	-6.0
5867.500000	48.85	74.00	25.15	150.0	H	239.0	3.9
17776.000000	53.33	74.00	20.67	150.0	H	250.0	19.2

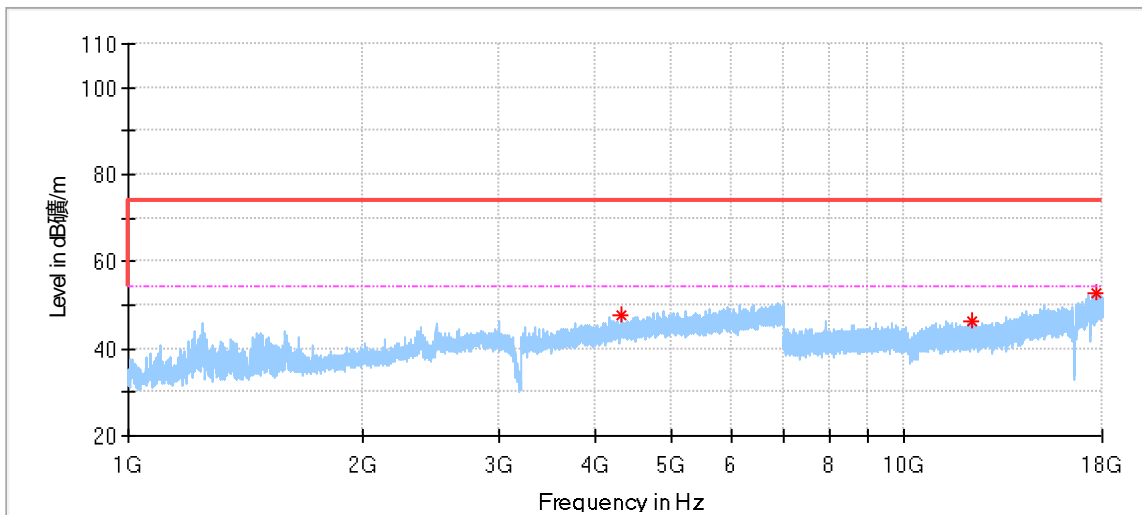

Frequency (MHz)	MaxPeak (dBµV/m)	Limit (dBµV/m)	Margin (dB)	Height (cm)	Pol	Azimuth (deg)	Corr. (dB/m)
4316.500000	47.59	74.00	26.41	150.0	V	321.0	2.0
12234.000000	46.45	74.00	27.55	150.0	V	307.0	8.3
17669.500000	52.72	74.00	21.28	150.0	V	204.0	18.6

802.11N40 mode 2452MHz Test Result

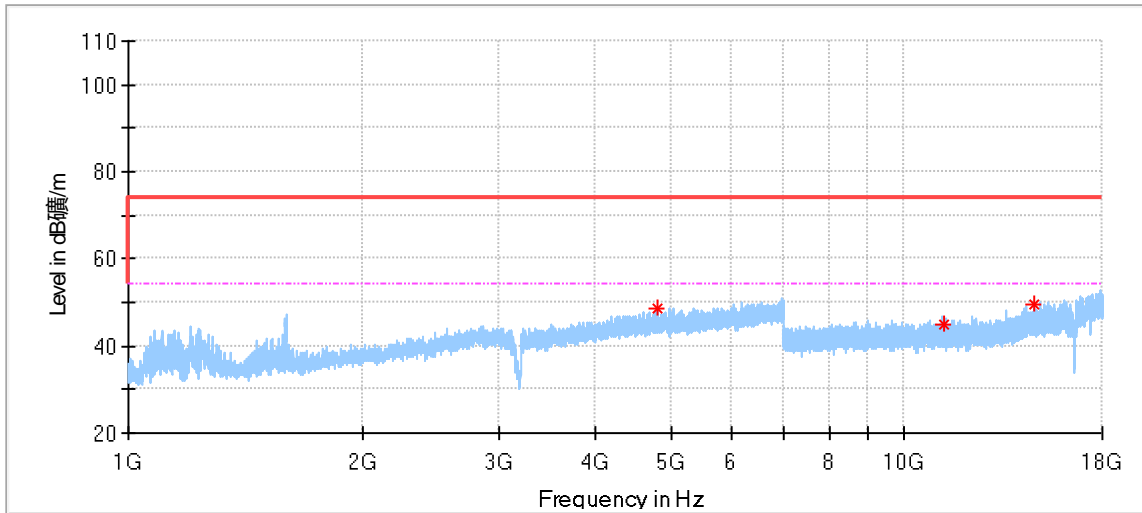

Frequency (MHz)	MaxPeak (dBμV/m)	Limit (dBμV/m)	Margin (dB)	Height (cm)	Pol	Azimuth (deg)	Corr. (dB/m)
4798.500000	48.51	74.00	25.49	150.0	H	288.0	2.2
11246.000000	45.13	74.00	28.87	150.0	H	111.0	7.5
14737.000000	49.49	74.00	24.51	150.0	H	40.0	11.9

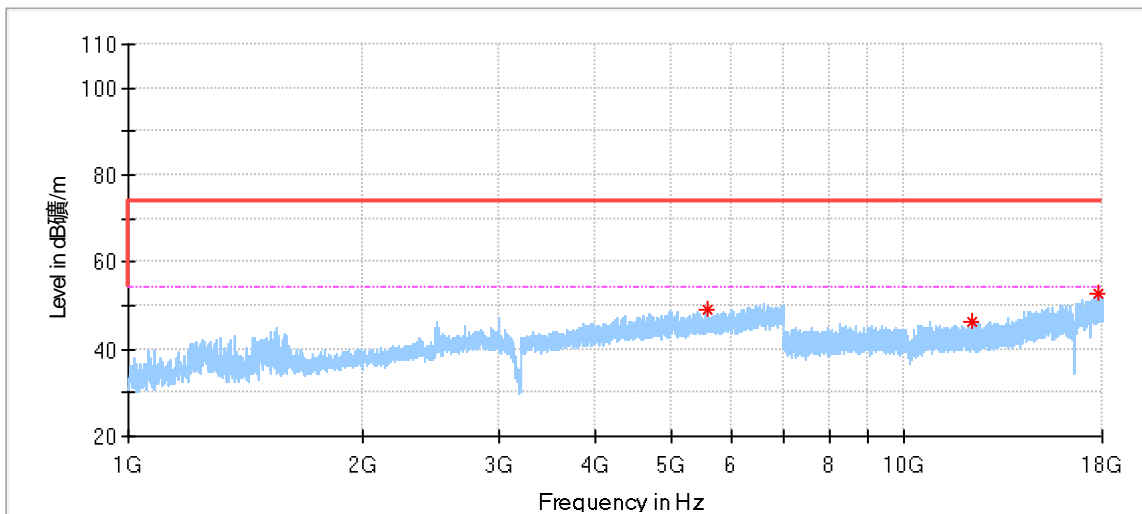

Frequency (MHz)	MaxPeak (dBμV/m)	Limit (dBμV/m)	Margin (dB)	Height (cm)	Pol	Azimuth (deg)	Corr. (dB/m)
5576.000000	49.05	74.00	24.95	150.0	V	178.0	2.4
12232.500000	46.47	74.00	27.53	150.0	V	35.0	8.3
17744.500000	52.78	74.00	21.22	150.0	V	333.0	19.3

Remark:

- (1) Data of measurement within this frequency range shown "--" in the table above means the reading of emissions are the noise floor or attenuated more than 10dB below the permissible limits or the field strength is too small to be measured.
- (2) Level=Reading Level + Correction Factor
 Above 1GHz: Corrector factor = Antenna Factor + Cable Loss- Amplifier Gain
 Below 1GHz: Corrector factor = Antenna Factor + Cable Loss
 (The Reading Level is recorded by software which is not shown in the sheet)

10 Test Equipment List

Radiated Emission Test

Description	Manufacturer	Model no.	Serial no.	cal. due date
EMI Test Receiver	Rohde & Schwarz	ESR 26	101269	2020-6-28
Trilog Super Broadband Test Antenna	Schwarzbeck	VULB 9163	707	2020-6-28
Horn Antenna	Rohde & Schwarz	HF907	102294	2020-6-22
Wideband Horn Antenna	Q-PAR	QWH-SL-18-40-K-SG	12827	2020-7-12
Pre-amplifier	Rohde & Schwarz	SCU 18	102230	2020-6-28
Signal Generator	Rohde & Schwarz	SMY01	839369/005	2020-6-28
Attenuator	Agilent	8491A	MY39264334	2020-6-28
3m Semi-anechoic chamber	TDK	9X6X6	----	2020-7-7
Test software	Rohde & Schwarz		Version 9.15.00	N/A

RF Conducted Test

DESCRIPTION	MANUFACTURER	MODEL NO.	SERIAL NO.	CAL. DUE DATE
Signal Analyzer	Rohde & Schwarz	FSV40	101030	2020-6-28
RF Switch Module	Rohde & Schwarz	OSP120/OSP-B157	101226/100851	2020-6-28
Power Splitter	Weinschel	1580	SC319	2020-7-7
10dB Attenuator	R&S	DNF	DNF-003	2020-6-28

Conducted Emission Test

Description	Manufacturer	Model no.	Serial no.	cal. due date
EMI Test Receiver	Rohde & Schwarz	ESR 3	101782	2021-6-29
LISN	Rohde & Schwarz	ENV4200	100249	2021-6-12
Attenuator	Shanghai Huaxiang	TS2-26-3	080928189	2021-6-21
Test software	Rohde & Schwarz	EMC32	Version9.15.00	N/A
Shielding Room	TDK	CSR #1	----	2020-11-07

11 System Measurement Uncertainty

For a 95% confidence level, the measurement expanded uncertainties for defined systems, in accordance with the recommendations of ISO 17025 were:

System Measurement Uncertainty

System Measurement Uncertainty	
Test Items	Extended Uncertainty
Uncertainty for Radiated Spurious Emission 25MHz-3000MHz	Horizontal: 4.91dB; Vertical: 4.89dB;
Uncertainty for Radiated Spurious Emission 3000MHz-18000MHz	Horizontal: 4.80dB; Vertical: 4.79dB;
Uncertainty for Conducted RF test with TS 8997	RF Power Conducted: 1.16dB Frequency test involved: 0.6x10 ⁻⁷ or 1%