



FCC RF Test Report

APPLICANT : ALPS ELECTRIC CO., LTD.
EQUIPMENT : LTE Data Module
BRAND NAME : ALPS
MODEL NAME : UMDZ1
MARKETING NAME : UMDZ1
FCC ID : 2ADOH-ALPSUMDZ1EVB1
STANDARD : FCC 47 CFR Part 2, 22(H), 24(E) , 27(L)
CLASSIFICATION : PCS Licensed Transmitter (PCB)

The product was received on Mar. 10, 2015 and testing was completed on Apr. 09, 2015. We, SPORTON INTERNATIONAL INC., would like to declare that the tested sample has been evaluated in accordance with the test procedures given in ANSI / TIA / EIA-603-C-2004 and has been in compliance with the applicable technical standards.

The test results in this report apply exclusively to the tested model / sample. Without written approval of SPORTON INTERNATIONAL INC., the test report shall not be reproduced except in full.

Reviewed by: Joseph Lin / Supervisor

Approved by: Jones Tsai / Manager



SPORTON INTERNATIONAL INC.

No. 52, Hwa Ya 1st Rd., Hwa Ya Technology Park, Kwei-Shan District, Tao Yuan City, Taiwan, R.O.C.



TABLE OF CONTENTS

REVISION HISTORY..... 3

SUMMARY OF TEST RESULT 4

1 GENERAL DESCRIPTION 5

 1.1 Applicant..... 5

 1.2 Manufacturer 5

 1.3 Product Feature of Equipment Under Test 5

 1.4 Product Specification subjective to this standard 6

 1.5 Modification of EUT 6

 1.6 Maximum ERP/EIRP Power, Frequency Tolerance, and Emission Designator 7

 1.7 Testing Location 7

 1.8 Applicable Standards 8

2 TEST CONFIGURATION OF EQUIPMENT UNDER TEST 9

 2.1 Test Mode..... 9

 2.2 Connection Diagram of Test System 11

 2.3 Support Unit used in test configuration 11

 2.4 Measurement Results Explanation Example 12

3 TEST RESULT 13

 3.1 Conducted Output Power Measurement 13

 3.2 Peak-to-Average Ratio 15

 3.3 99% Occupied Bandwidth and 26dB Bandwidth Measurement..... 31

 3.4 Band Edge Measurement..... 54

 3.5 Conducted Spurious Emission Measurement 62

 3.6 Field Strength of Spurious Radiation Measurement 85

 3.7 Frequency Stability Measurement..... 108

4 LIST OF MEASURING EQUIPMENT 114

5 UNCERTAINTY OF EVALUATION 115

APPENDIX A. SETUP PHOTOGRAPHS



SUMMARY OF TEST RESULT

Report Section	FCC Rule	IC Rule	Description	Limit	Result	Remark
3.1	§2.1046	RSS-132 (5.4) RSS-133 (6.4) RSS-139 (6.4)	Conducted Output Power	N/A	PASS	-
3.2	§24.232(d)	RSS-132 (5.4) RSS-133 (6.4) RSS-139 (6.4)	Peak-to-Average Ratio	<13 dB	PASS	-
3.3	§2.1049 §22.917(b) §24.238(b) §27.53(g)	RSS-GEN(4.6.1) RSS-133(6.5) RSS-139 (6.5)	Occupied Bandwidth	N/A	PASS	-
3.4	§2.1051 §22.917(a) §24.238(a) §27.53(h)	RSS-132 (5.5) RSS-133 (6.5) RSS-139 (6.5)	Band Edge Measurement	< 43+10log ₁₀ (P[Watts])	PASS	-
3.5	§2.1051 §22.917(a) §24.238(a) §27.53(h)	RSS-132 (5.5) RSS-133 (6.5) RSS-139 (6.5)	Conducted Spurious Emission	< 43+10log ₁₀ (P[Watts])	PASS	-
3.6	§2.1053 §22.917(a) §24.238(a) §27.53(h)	RSS-132 (5.5) RSS-133 (6.5) RSS-139 (6.5)	Field Strength of Spurious Radiation	< 43+10log ₁₀ (P[Watts])	PASS	Under limit 6.40 dB at 7641.000 MHz
3.7	§2.1055 §22.355	RSS-GEN(6.11) RSS-132 (5.3)	Frequency Stability for Temperature & Voltage	< 2.5 ppm for Part 22 Within Authorized Band	PASS	-
	§2.1055 §24.235 §27.54	RSS-GEN(6.11) RSS-133 (6.3) RSS-139 (6.3)				



1 General Description

1.1 Applicant

ALPS ELECTRIC CO., LTD.

6-3-36, Furukawanakazato, Osaki City, Miyagi Prefecture 989-6181

1.2 Manufacturer

ALPS ELECTRIC CO., LTD.

6-3-36, Furukawanakazato, Osaki City, Miyagi Prefecture 989-6181

1.3 Product Feature of Equipment Under Test

Product Feature	
Equipment	LTE Data Module
Brand Name	ALPS
Model Name	UMDZ1
Marketing Name	UMDZ1
FCC ID	2ADOH-ALPSUMDZ1EV B1
EUT supports Radios application	GSM/EGPRS/WCDMA/HSPA/LTE
HW Version	ES2.0
SW Version	V15.2
EUT Stage	Identical Prototype

Remark: The above EUT's information was declared by manufacturer. Please refer to the specifications or user's manual for more detailed description.

1.4 Product Specification subjective to this standard

Product Specification subjective to this standard	
Tx Frequency	GSM850: 824.2 MHz ~ 848.8 MHz GSM1900: 1850.2 MHz ~ 1909.8MHz WCDMA Band IV: 1712.4 MHz ~ 1752.6 MHz WCDMA Band V: 826.4 MHz ~ 846.6 MHz WCDMA Band II: 1852.4 MHz ~ 1907.6 MHz
Rx Frequency	GSM850: 869.2 MHz ~ 893.8 MHz GSM1900: 1930.2 MHz ~ 1989.8 MHz WCDMA Band IV : 2112.4 MHz ~ 2152.6 MHz WCDMA Band V: 871.4 MHz ~ 891.6 MHz WCDMA Band II: 1932.4 MHz ~ 1987.6 MHz
Maximum Output Power to Antenna	GSM850 : 32.30 dBm GSM1900 : 29.51 dBm WCDMA Band IV : 22.48 dBm WCDMA Band V : 22.95 dBm WCDMA Band II : 22.66 dBm
99% Occupied Bandwidth	GSM850: 2.49MHz GSM1900: 2.47MHz WCDMA Band IV: 4.15MHz WCDMA Band V: 4.14MHz WCDMA Band II: 4.14MHz
Antenna Type	Fixed External Antenna
Type of Modulation	GSM: GMSK GPRS: GMSK EDGE: GMSK / 8PSK WCDMA: QPSK (Uplink) HSDPA: QPSK (Downlink) HSUPA: QPSK (Uplink)

1.5 Modification of EUT

No modifications are made to the EUT during all test items.



1.6 Maximum ERP/EIRP Power, Frequency Tolerance, and Emission Designator

FCC Rule	System	Type of Modulation	Frequency Tolerance (ppm)	Emission Designator
Part 22	GSM850 GPRS class 8	GMSK	0.0096 ppm	248KGXW
Part 22	GSM850 EDGE class 8	8PSK	0.0383 ppm	249KG7W
Part 22	WCDMA Band V RMC 12.2Kbps	QPSK	0.0299 ppm	4M14F9W
Part 24	GSM1900 GPRS class 8	GMSK	0.0388 ppm	247KGXW
Part 24	GSM1900 EDGE class 8	8PSK	0.0032 ppm	246KG7W
Part 24	WCDMA Band II RMC 12.2Kbps	QPSK	0.0176 ppm	4M14F9W
Part 27	WCDMA Band IV RMC 12.2Kbps	QPSK	0.0202 ppm	4M15F9W

1.7 Testing Location

Sporton Lab is accredited to ISO 17025 by Taiwan Accreditation Foundation (TAF code : 1190) and the FCC designation No. TW1022 under the FCC 2.948(e) by Mutual Recognition Agreement (MRA) in FCC Test.

Test Site	SPORTON INTERNATIONAL INC.	
Test Site Location	No. 52, Hwa Ya 1 st Rd., Hwa Ya Technology Park, Kwei-Shan District, Tao Yuan City, Taiwan, R.O.C. TEL: +886-3-327-3456 FAX: +886-3-328-4978	
Test Site No.	Sporton Site No.	
	TH02-HY	03CH07-HY



1.8 Applicable Standards

According to the specifications of the manufacturer, the EUT must comply with the requirements of the following standards:

- ♦ FCC 47 CFR Part 2, 22(H), 24(E), 27(L)
- ♦ ANSI / TIA / EIA-603-C-2004
- ♦ FCC KDB 971168 D01 Power Meas. License Digital Systems v02r02

Remark:

1. All test items were verified and recorded according to the standards and without any deviation during the test.
2. This EUT has also been tested and complied with the requirements of FCC Part 15, Subpart B, recorded in a separate test report.



2 Test Configuration of Equipment Under Test

2.1 Test Mode

Antenna port conducted and radiated test items were performed according to KDB 971168 D01 Power Meas. License Digital Systems v02r02 with maximum output power.

Radiated emissions were investigated as following frequency range:

1. 30 MHz to 9000 MHz for GSM850 and WCDMA Band V.
2. 30 MHz to 18000 MHz for WCDMA Band IV
3. 30 MHz to 19000 MHz for GSM1900 and WCDMA Band II.

All modes and data rates and positions were investigated.

Test modes are chosen to be reported as the worst case configuration below:

Test Modes		
Band	Radiated TCs	Conducted TCs
GSM 850	<ul style="list-style-type: none"> ■ GPRS class 8 Link ■ EDGE class 8 Link 	<ul style="list-style-type: none"> ■ GPRS class 8 Link ■ EDGE class 8 Link
GSM 1900	<ul style="list-style-type: none"> ■ GPRS class 8 Link ■ EDGE class 8 Link 	<ul style="list-style-type: none"> ■ GPRS class 8 Link ■ EDGE class 8 Link
WCDMA Band V	<ul style="list-style-type: none"> ■ RMC 12.2Kbps Link 	<ul style="list-style-type: none"> ■ RMC 12.2Kbps Link
WCDMA Band II	<ul style="list-style-type: none"> ■ RMC 12.2Kbps Link 	<ul style="list-style-type: none"> ■ RMC 12.2Kbps Link
WCDMA Band IV	<ul style="list-style-type: none"> ■ RMC 12.2Kbps Link 	<ul style="list-style-type: none"> ■ RMC 12.2Kbps Link

Note: The maximum power levels are chosen to test as the worst case configuration as follows:

- GPRS multi-slot class 8 mode for GMSK modulation,
- EDGE multi-slot class 8 mode for 8PSK modulation,
- RMC 12.2Kbps mode for WCDMA band V and WCDMA band IV,
- RMC 12.2Kbps mode for WCDMA band II, only these modes were used for all tests.



Conducted Power Measurement Results:

Conducted Power (*Unit: dBm)						
Band	GSM850			GSM1900		
Channel	128	189	251	512	661	810
Frequency	824.2	836.4	848.8	1850.2	1880.0	1909.8
GPRS class 8	32.08	32.16	32.30	29.51	29.41	28.96
GPRS class 10	30.72	30.81	30.95	28.38	28.16	27.58
GPRS class 11	28.74	28.81	28.90	26.43	26.15	25.53
GPRS class 12	27.69	27.78	27.92	25.39	25.14	24.57
EGPRS class 8	26.26	26.19	26.11	26.68	26.37	25.65
EGPRS class 10	24.47	24.33	24.37	26.56	26.29	25.63
EGPRS class 11	22.73	22.52	22.32	26.44	26.14	25.53
EGPRS class 12	21.63	21.40	21.38	25.37	25.13	24.53

Conducted Power (*Unit: dBm)									
Band	WCDMA Band V			WCDMA Band II			WCDMA Band IV		
Channel	4132	4182	4233	9262	9400	9538	1312	1413	1513
Frequency	826.4	836.4	846.6	1852.4	1880	1907.6	1712.4	1732.6	1752.6
RMC 12.2K	22.16	22.95	22.27	22.30	22.38	22.66	22.29	22.48	22.34
HSDPA Subtest-1	22.17	22.82	22.24	22.35	22.34	22.40	22.12	22.40	22.35
HSDPA Subtest-2	22.16	22.83	22.28	22.25	22.34	22.36	22.02	22.27	22.15
HSDPA Subtest-3	21.77	22.42	21.89	21.87	22.00	22.16	21.70	21.90	21.85
HSDPA Subtest-4	21.73	22.40	21.89	21.90	22.00	22.12	21.75	21.96	21.88
HSUPA Subtest-1	22.03	22.58	22.14	22.15	22.19	22.40	21.31	21.46	21.36
HSUPA Subtest-2	20.16	20.66	20.26	19.98	19.91	20.27	20.45	20.59	20.48
HSUPA Subtest-3	20.55	21.09	20.69	20.96	20.93	21.07	19.98	20.01	19.99
HSUPA Subtest-4	20.09	20.54	20.17	20.47	20.43	20.56	20.36	20.47	20.40
HSUPA Subtest-5	22.16	22.70	22.20	22.30	22.29	22.54	22.25	22.39	22.30

2.2 Connection Diagram of Test System

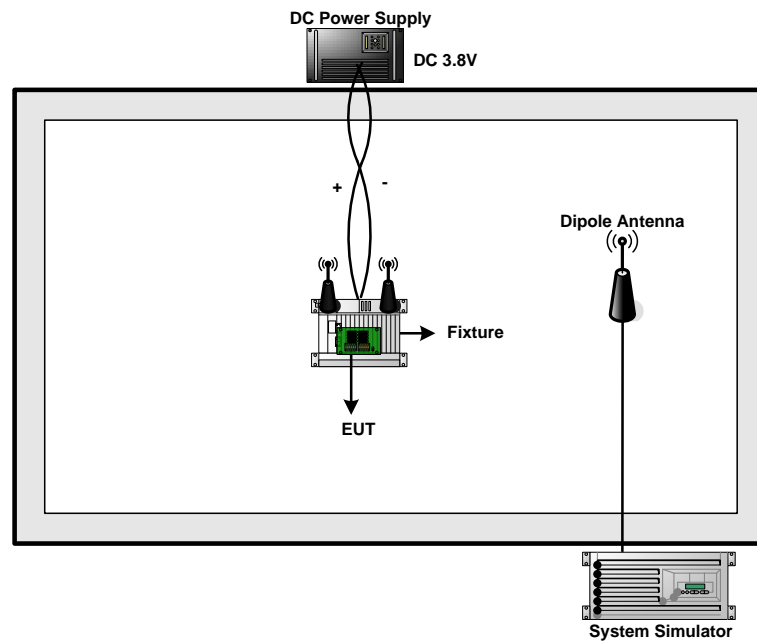

2.3 Support Unit used in test configuration

Item	Equipment	Trade Name	Model No.	FCC ID	Data Cable	Power Cord
1.	System Simulator	R&S	CMU 200	N/A	N/A	Unshielded, 1.8 m
2.	Power Supply	PSS-2005	N/A	N/A	N/A	Unshielded, 1.8
3.	Fixture	N/A	N/A	N/A	N/A	N/A
4.	Antenna	N/A	N/A	N/A	N/A	N/A



2.4 Measurement Results Explanation Example

For all conducted test items:

The offset level is set in the spectrum analyzer to compensate the RF cable loss and attenuator factor between RF conducted output port and spectrum analyzer. With the offset compensation, the spectrum analyzer reading level will be exactly the RF output level.

The spectrum analyzer offset is derived from RF cable loss and attenuator factor.

Offset = RF cable loss + attenuator factor.

The following shows an offset computation example with RF cable loss 4.2 dB and a 10dB attenuator.

Example :

$$\begin{aligned} \text{Offset(dB)} &= \text{RF cable loss(dB)} + \text{attenuator factor(dB)} \\ &= 4.2 + 10 = 14.2 \text{ (dB)} \end{aligned}$$

3 Test Result

3.1 Conducted Output Power Measurement

3.1.1 Description of the Conducted Output Power Measurement

A system simulator was used to establish communication with the EUT. Its parameters were set to enforce EUT transmitting at the maximum power. The measured power in the radio frequency on the transmitter output terminals shall be reported.

3.1.2 Measuring Instruments

The measuring equipment is listed in the section 4 of this test report.

3.1.3 Test Procedures

1. The transmitter output port was connected to the system simulator.
2. Set EUT at maximum power through system simulator.
3. Select lowest, middle, and highest channels for each band and different modulation.
4. Measure the maximum burst average power for GSM and maximum average power for other modulation signal.

3.1.4 Test Setup

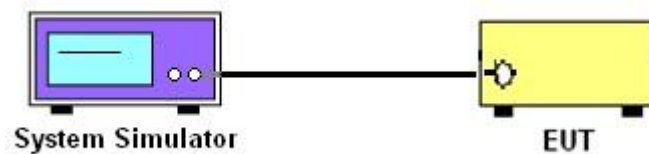



3.1.5 Test Result of Conducted Output Power

Cellular Band									
Modes	GSM850 (GPRS class 8)			GSM850 (EDGE class 8)			WCDMA Band V (RMC 12.2Kbps)		
Channel	128 (Low)	189 (Mid)	251 (High)	128 (Low)	189 (Mid)	251 (High)	4132 (Low)	4182 (Mid)	4233 (High)
Frequency (MHz)	824.2	836.4	848.8	824.2	836.4	848.8	826.4	836.4	846.6
Conducted Power (dBm)	32.08	32.16	32.30	26.26	26.19	26.11	22.16	22.95	22.27

PCS Band									
Modes	GSM1900 (GPRS class 8)			GSM1900 (EDGE class 8)			WCDMA Band II (RMC 12.2Kbps)		
Channel	512 (Low)	661 (Mid)	810 (High)	512 (Low)	661 (Mid)	810 (High)	9262 (Low)	9400 (Mid)	9538 (High)
Frequency (MHz)	1850.2	1880	1909.8	1850.2	1880	1909.8	1852.4	1880	1907.6
Conducted Power (dBm)	29.51	29.41	28.96	26.68	26.37	25.65	22.30	22.38	22.66

AWS Band			
Modes	WCDMA Band IV (RMC 12.2Kbps)		
Channel	1312(Low)	1413 (Mid)	1513 (High)
Frequency (MHz)	1712.4	1732.6	1752.6
Conducted Power (dBm)	22.29	22.48	22.34

Note: maximum burst average power for GSM, and maximum average power for WCDMA.

3.2 Peak-to-Average Ratio

3.2.1 Description of the PAR Measurement

The peak-to-average ratio (PAR) of the transmission may not exceed 13 dB.

3.2.2 Measuring Instruments

The measuring equipment is listed in the section 4 of this test report.

3.2.3 Test Procedures

1. The testing follows FCC KDB 971168 v02r02 Section 5.7.1.
2. Record the deviation as Peak to Average Ratio.
3. The EUT was connected to spectrum analyzer and system simulator via a power divider.
4. Set EUT to transmit at maximum output power.
5. When the duty cycle is less than 98%, then signal gating will be implemented on the spectrum analyzer by triggering from the system simulator.
6. Set the CCDF (Complementary Cumulative Distribution Function) option of the spectrum analyzer.
Record the maximum PAPR level associated with a probability of 0.1%.

3.2.4 Test Setup

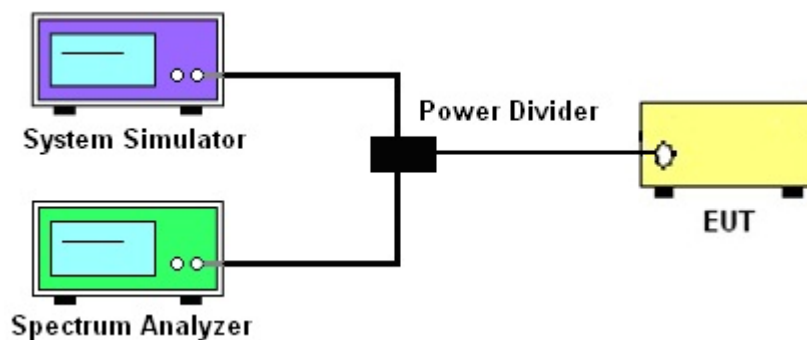



3.2.5 Test Result of Peak-to-Average Ratio

Cellular Band									
Modes	GSM850 (GPRS class 8)			GSM850 (EDGE class 8)			WCDMA Band V (RMC 12.2Kbps)		
Channel	128 (Low)	189 (Mid)	251 (High)	128 (Low)	189 (Mid)	251 (High)	4132 (Low)	4182 (Mid)	4233 (High)
Frequency (MHz)	824.2	836.4	848.8	824.2	836.4	848.8	826.4	836.4	846.6
Peak-to-Average Ratio (dB)	0.24	0.24	0.24	3.44	3.44	3.28	3.24	3.08	3.08

PCS Band									
Modes	GSM1900 (GPRS class 8)			GSM1900 (EDGE class 8)			WCDMA Band II (RMC 12.2Kbps)		
Channel	512 (Low)	661 (Mid)	810 (High)	512 (Low)	661 (Mid)	810 (High)	9262 (Low)	9400 (Mid)	9538 (High)
Frequency (MHz)	1850.2	1880	1909.8	1850.2	1880	1909.8	1852.4	1880	1907.6
Peak-to-Average Ratio (dB)	0.24	0.24	0.24	3.60	3.92	3.96	2.88	3.00	2.96

AWS Band			
Modes	WCDMA Band IV (RMC 12.2Kbps)		
Channel	1312(Low)	1413 (Mid)	1513 (High)
Frequency (MHz)	1712.4	1732.6	1752.6
Peak-to-Average Ratio (dB)	2.96	2.88	3.08



3.2.6 Test Result (Plots) of Peak-to-Average Ratio

Band :	GSM 850	Test Mode :	GPRS class 8 Link (GMSK)
--------	---------	-------------	--------------------------

Peak-to-Average Ratio on Channel 128 (824.2 MHz)

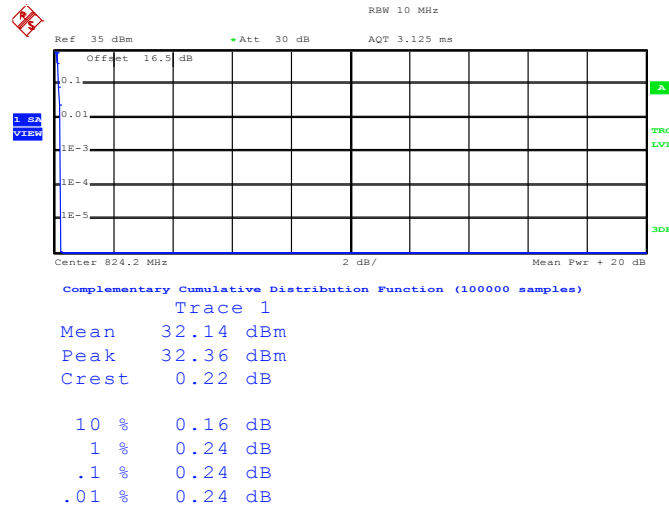

Date: 18.MAR.2015 14:16:12

Peak-to-Average Ratio on Channel 189 (836.4 MHz)

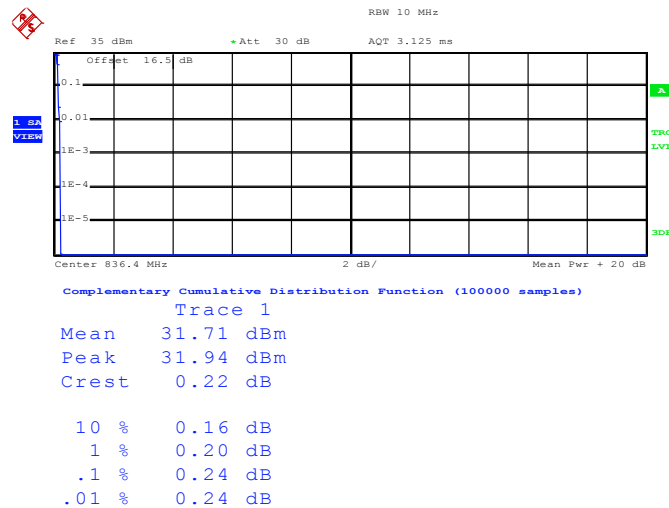

Date: 18.MAR.2015 14:16:27



Peak-to-Average Ratio on Channel 251 (848.8 MHz)

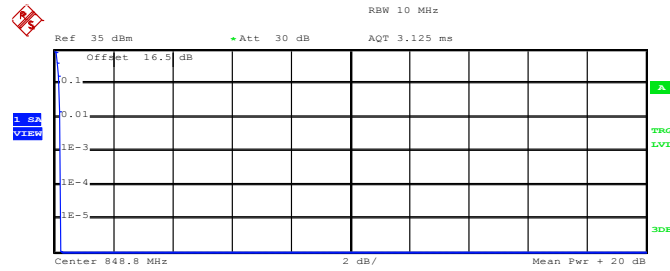

Complementary Cumulative Distribution Function (100000 samples)

Trace 1

Mean	31.10 dBm
Peak	31.30 dBm
Crest	0.20 dB
10 %	0.16 dB
1 %	0.20 dB
.1 %	0.24 dB
.01 %	0.24 dB

Date: 18.MAR.2015 14:16:41



Band :	GSM 850	Test Mode :	EDGE class 8 Link (8PSK)
---------------	---------	--------------------	--------------------------

Peak-to-Average Ratio on Channel 128 (824.2 MHz)

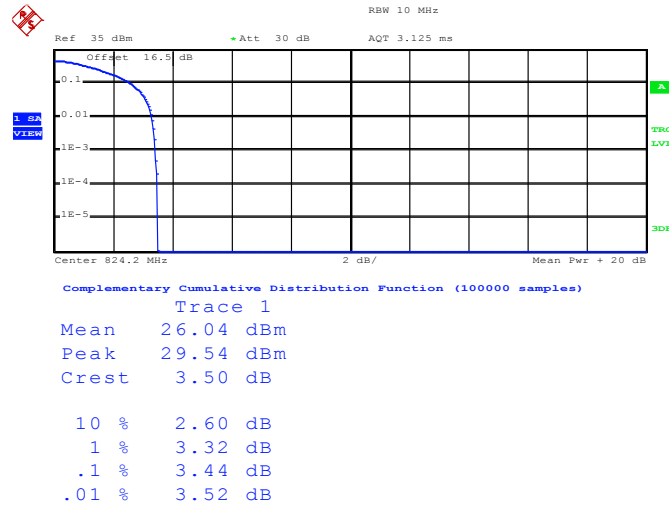

Date: 18.MAR.2015 14:32:36

Peak-to-Average Ratio on Channel 189 (836.4 MHz)

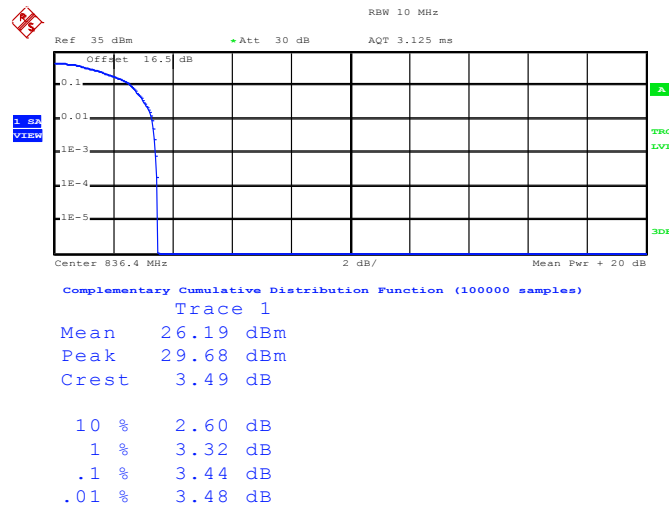

Date: 18.MAR.2015 14:33:25



Peak-to-Average Ratio on Channel 251 (848.8 MHz)

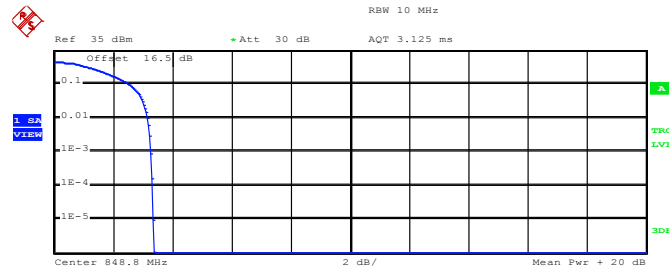

Complementary Cumulative Distribution Function (100000 samples)

Trace 1

Mean	26.18 dBm
Peak	29.54 dBm
Crest	3.36 dB
10 %	2.56 dB
1 %	3.16 dB
.1 %	3.28 dB
.01 %	3.32 dB

Date: 18.MAR.2015 14:33:41



Band :	GSM 1900	Test Mode :	GPRS class 8 Link (GMSK)
---------------	----------	--------------------	--------------------------

Peak-to-Average Ratio on Channel 512 (1850.2 MHz)

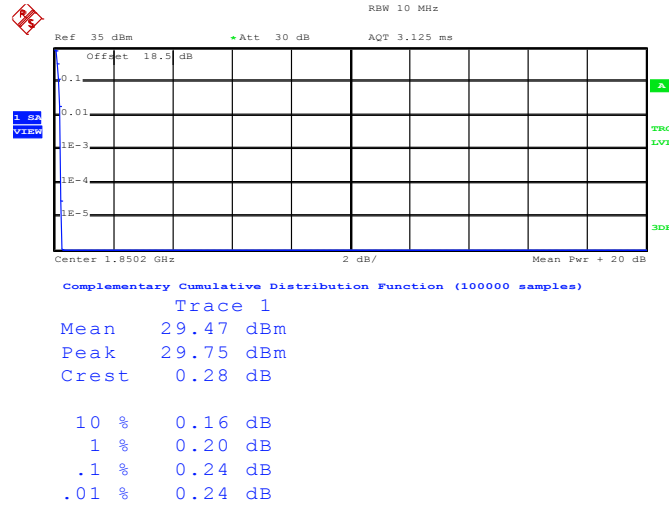

Date: 18.MAR.2015 15:13:38

Peak-to-Average Ratio on Channel 661 (1880.0 MHz)

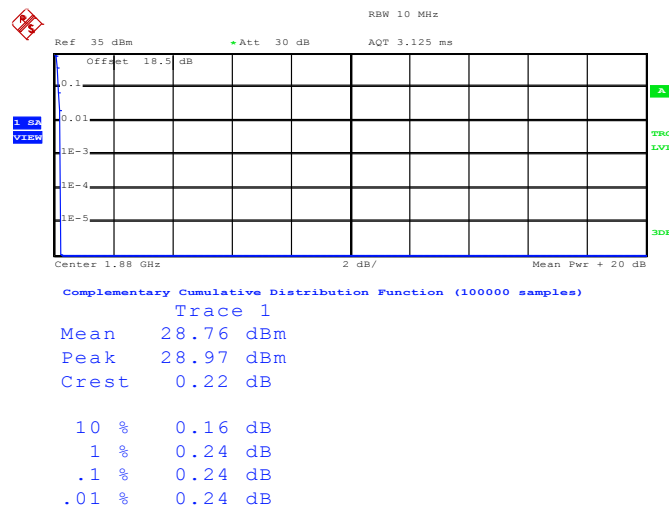

Date: 18.MAR.2015 15:13:50



Peak-to-Average Ratio on Channel 810 (1909.8 MHz)

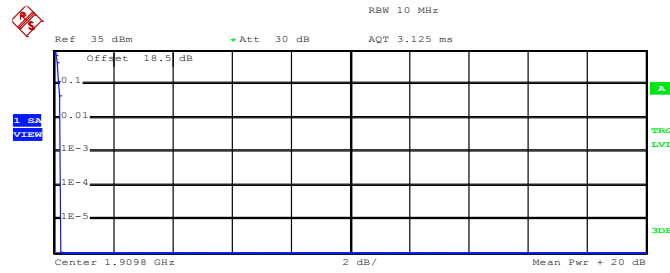

Complementary Cumulative Distribution Function (100000 samples)

Trace 1

Mean	29.16 dBm
Peak	29.40 dBm
Crest	0.23 dB
10 %	0.16 dB
1 %	0.24 dB
.1 %	0.24 dB
.01 %	0.24 dB

Date: 18.MAR.2015 15:14:05



Band :	GSM 1900	Test Mode :	EDGE class 8 Link (8PSK)
---------------	----------	--------------------	--------------------------

Peak-to-Average Ratio on Channel 512 (1850.2 MHz)

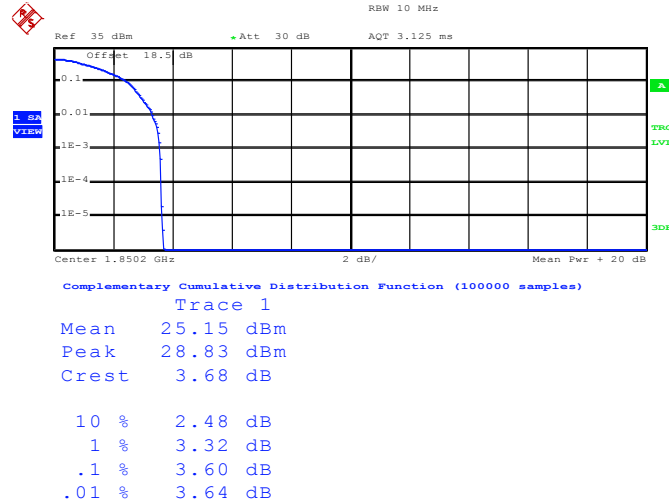

Date: 18.MAR.2015 15:35:26

Peak-to-Average Ratio on Channel 661 (1880.0 MHz)

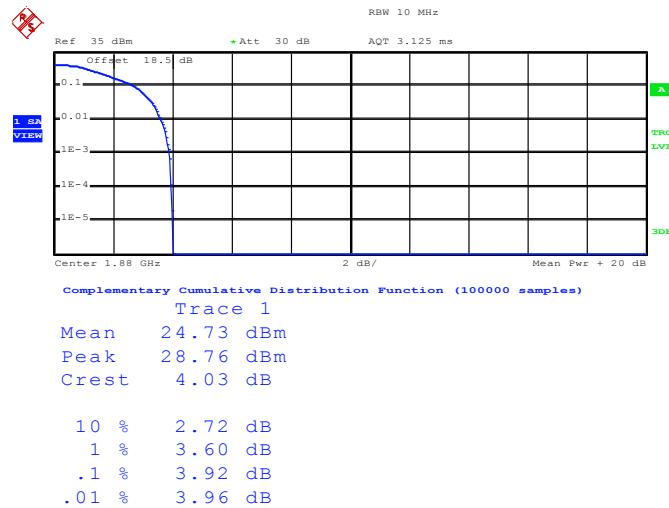

Date: 18.MAR.2015 15:35:39



Peak-to-Average Ratio on Channel 810 (1909.8 MHz)

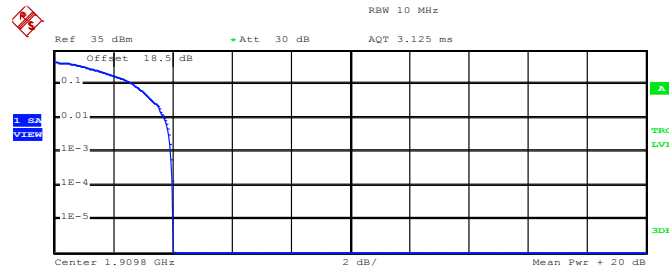

Complementary Cumulative Distribution Function (100000 samples)

Trace 1	
Mean	24.76 dBm
Peak	28.76 dBm
Crest	4.00 dB
10 %	2.68 dB
1 %	3.72 dB
.1 %	3.96 dB
.01 %	4.00 dB

Date: 18.MAR.2015 15:35:57



Band :	WCDMA Band V	Test Mode :	RMC 12.2Kbps Link (QPSK)
---------------	--------------	--------------------	--------------------------

Peak-to-Average Ratio on Channel 4132 (826.4 MHz)

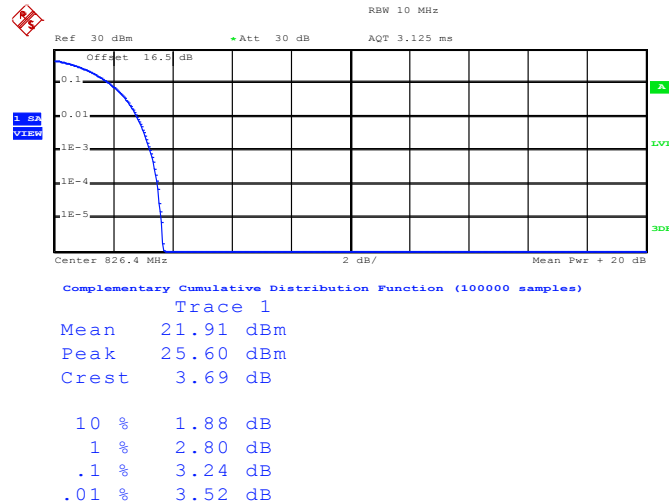

Date: 18.MAR.2015 14:50:14

Peak-to-Average Ratio on Channel 4182 (836.4 MHz)

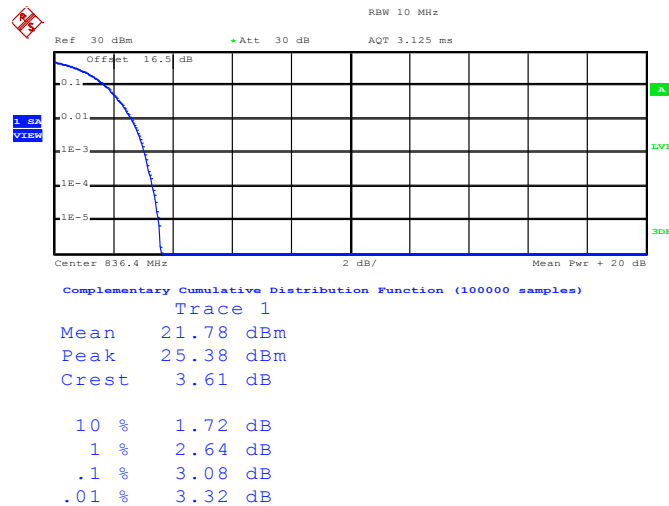

Date: 18.MAR.2015 14:50:23



Peak-to-Average Ratio on Channel 4233 (846.6 MHz)

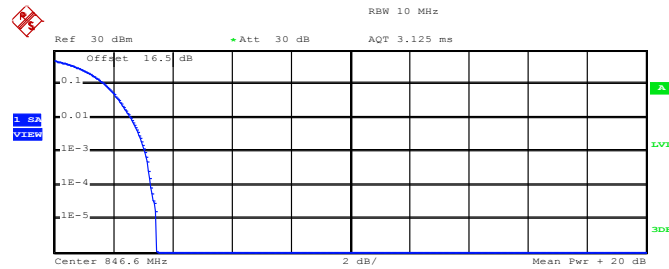

Complementary Cumulative Distribution Function (100000 samples)

Trace 1

Mean	22.62 dBm
Peak	26.09 dBm
Crest	3.47 dB
10 %	1.72 dB
1 %	2.60 dB
.1 %	3.08 dB
.01 %	3.28 dB

Date: 18.MAR.2015 14:50:32



Band :	WCDMA Band IV	Test Mode :	RMC 12.2Kbps Link (QPSK)
---------------	---------------	--------------------	--------------------------

Peak-to-Average Ratio on Channel 1312 (1712.4 MHz)

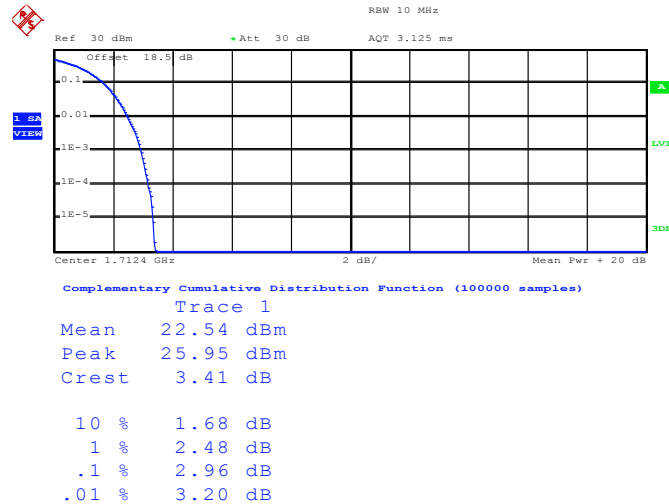

Date: 30.MAR.2015 10:33:12

Peak-to-Average Ratio on Channel 1413 (1732.6 MHz)

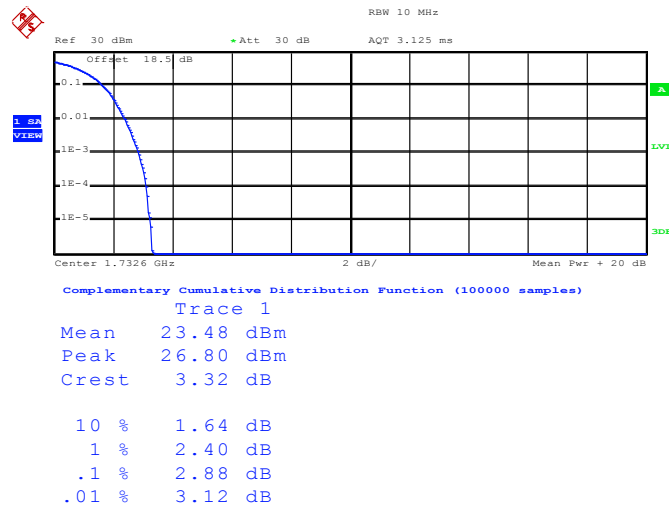

Date: 30.MAR.2015 10:33:28



Peak-to-Average Ratio on Channel 1513 (1752.6 MHz)

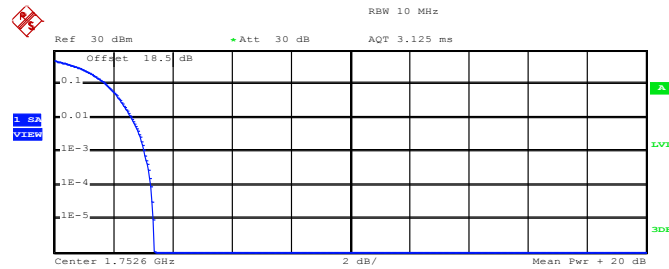

Complementary Cumulative Distribution Function (100000 samples)

Trace 1
 Mean 21.87 dBm
 Peak 25.25 dBm
 Crest 3.37 dB

10 % 1.76 dB
 1 % 2.64 dB
 .1 % 3.08 dB
 .01 % 3.28 dB

Date: 30.MAR.2015 10:33:46



Band :	WCDMA Band II	Test Mode :	RMC 12.2Kbps Link (QPSK)
---------------	---------------	--------------------	--------------------------

Peak-to-Average Ratio on Channel 9262 (1852.4 MHz)

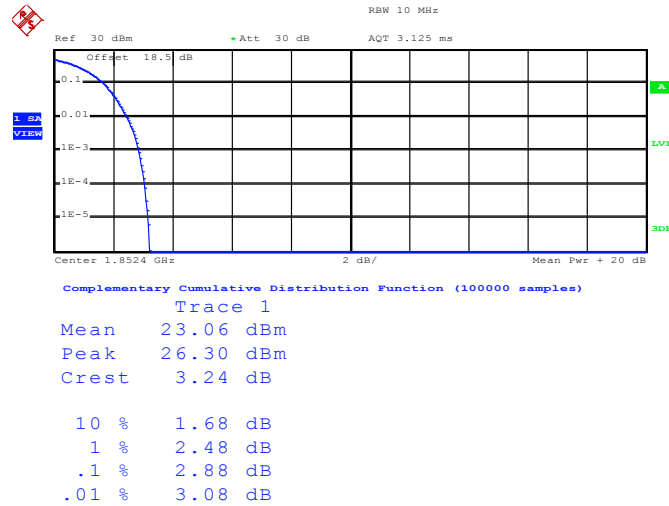

Date: 18.MAR.2015 15:51:05

Peak-to-Average Ratio on Channel 9400 (1880.0 MHz)

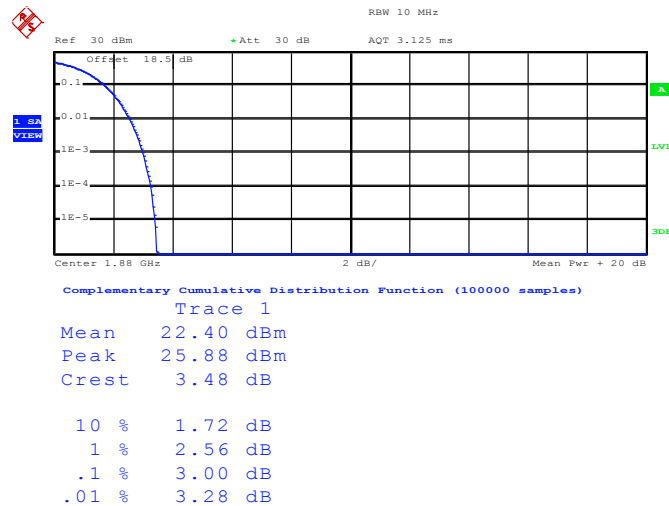

Date: 18.MAR.2015 15:51:15



Peak-to-Average Ratio on Channel 9538 (1907.6 MHz)

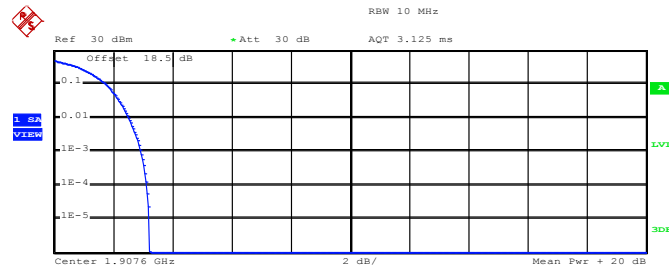

Complementary Cumulative Distribution Function (100000 samples)

Trace 1

Mean	22.16 dBm
Peak	25.38 dBm
Crest	3.22 dB
10 %	1.76 dB
1 %	2.52 dB
.1 %	2.96 dB
.01 %	3.12 dB

Date: 18.MAR.2015 15:51:41

3.3 99% Occupied Bandwidth and 26dB Bandwidth Measurement

3.3.1 Description of 99% Occupied Bandwidth and 26dB Bandwidth Measurement

The 99% occupied bandwidth is the width of a frequency band such that, below the lower and above the upper frequency limits, the mean powers emitted are each equal to a specified percentage 0.5% of the total mean transmitted power.

The emission bandwidth is defined as the width of the signal between two points, located at the 2 sides of the carrier frequency, outside of which all emissions are attenuated at least 26 dB below the transmitter power.

3.3.2 Measuring Instruments

The measuring equipment is listed in the section 4 of this test report.

3.3.3 Test Procedures

1. The testing follows FCC KDB 971168 v02r02 Section 4.2.
2. The EUT was connected to the spectrum analyzer and system simulator via a power divider.
3. The RF output of the EUT was connected to the spectrum analyzer by RF cable and attenuator. The path loss was compensated to the results for each measurement.
4. The 99% occupied bandwidth were measured, set RBW= 1% of span, VBW= 3*RBW, sample detector, trace maximum hold.
5. The 26dB bandwidth were measured, set RBW= 1% of EBW, VBW= 3*RBW, peak detector, trace maximum hold.

3.3.4 Test Setup

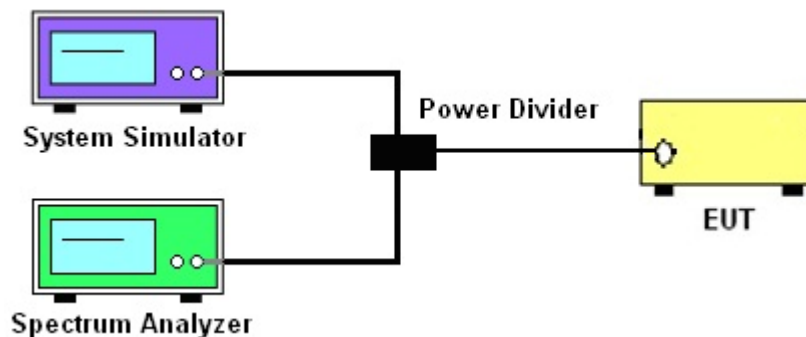



3.3.5 Test Result of Occupied Bandwidth and 26dB Bandwidth

Cellular Band						
Modes	GSM850 (GPRS class 8)			GSM850 (EDGE class 8)		
Channel	128 (Low)	189 (Mid)	251 (High)	128 (Low)	189 (Mid)	251 (High)
Frequency (MHz)	824.2	836.4	848.8	824.2	836.4	848.8
99% OBW (kHz)	243.00	248.00	247.00	246.00	246.00	249.00
26dB BW (kHz)	316.00	316.00	315.00	312.00	302.00	301.00

PCS Band						
Modes	GSM1900 (GPRS class 8)			GSM1900 (EDGE class 8)		
Channel	512 (Low)	661 (Mid)	810 (High)	512 (Low)	661 (Mid)	810 (High)
Frequency (MHz)	1850.2	1880	1909.8	1850.2	1880	1909.8
99% OBW (kHz)	246.00	247.00	246.00	246.00	243.00	246.00
26dB BW (kHz)	306.00	286.00	312.00	298.00	309.00	310.00

Cellular Band			
Modes	WCDMA Band V (RMC 12.2Kbps)		
Channel	4132 (Low)	4182 (Mid)	4233 (High)
Frequency (MHz)	826.4	836.4	846.6
99% OBW (MHz)	4.14	4.14	4.12
26dB BW (MHz)	4.72	4.73	4.69

AWS Band			
Modes	WCDMA Band IV (RMC 12.2Kbps)		
Channel	1312(Low)	1413 (Mid)	1513 (High)
Frequency (MHz)	1712.4	1732.6	1752.6
99% OBW (MHz)	4.13	4.14	4.15
26dB BW (MHz)	4.71	4.71	4.71



PCS Band			
Modes	WCDMA Band II (RMC 12.2Kbps)		
Channel	9262 (Low)	9400 (Mid)	9538 (High)
Frequency (MHz)	1852.4	1880	1907.6
99% OBW (MHz)	4.13	4.14	4.14
26dB BW (MHz)	4.72	4.71	4.74



3.3.6 Test Result (Plots) of Occupied Bandwidth and 26dB Bandwidth

Band :	GSM 850	Test Mode :	GPRS class 8 Link (GMSK)
--------	---------	-------------	--------------------------

99% Occupied Bandwidth Plot on Channel 128 (824.2 MHz)

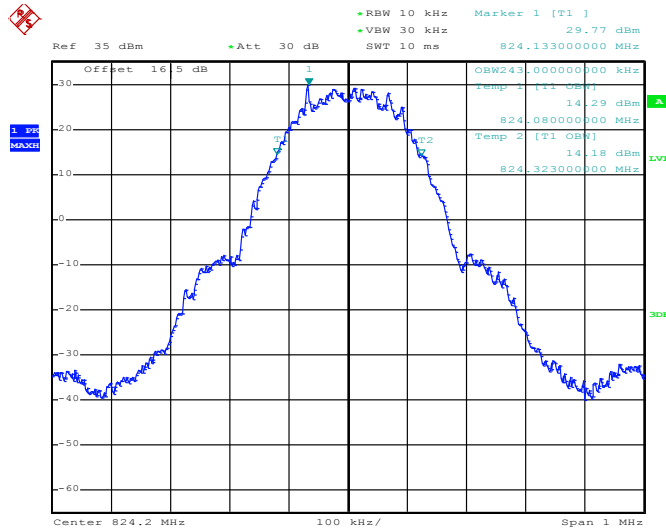

Date: 18.MAR.2015 14:09:35

26dB Bandwidth Plot on Channel 128 (824.2 MHz)

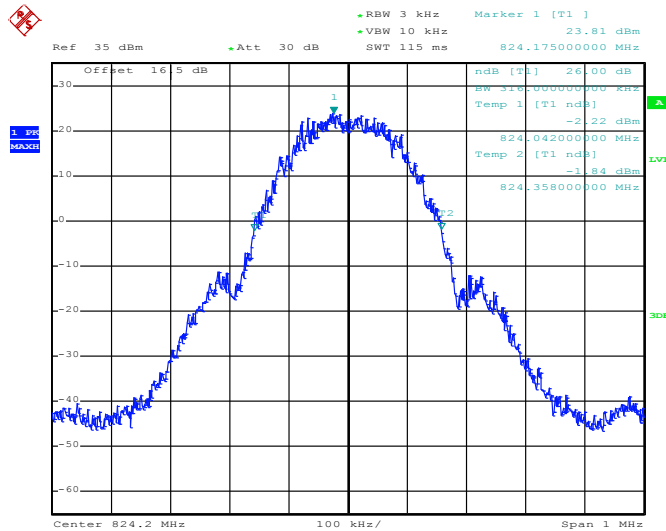

Date: 18.MAR.2015 14:07:43



99% Occupied Bandwidth Plot on Channel 189 (836.4 MHz)

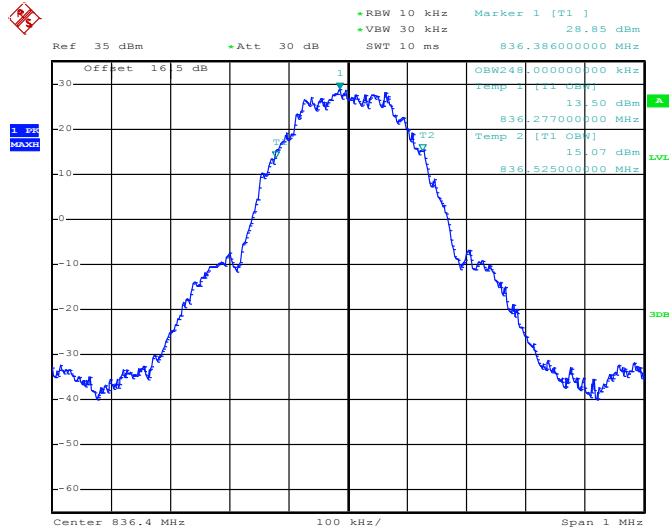

Date: 18.MAR.2015 14:10:08

26dB Bandwidth Plot on Channel 189 (836.4 MHz)

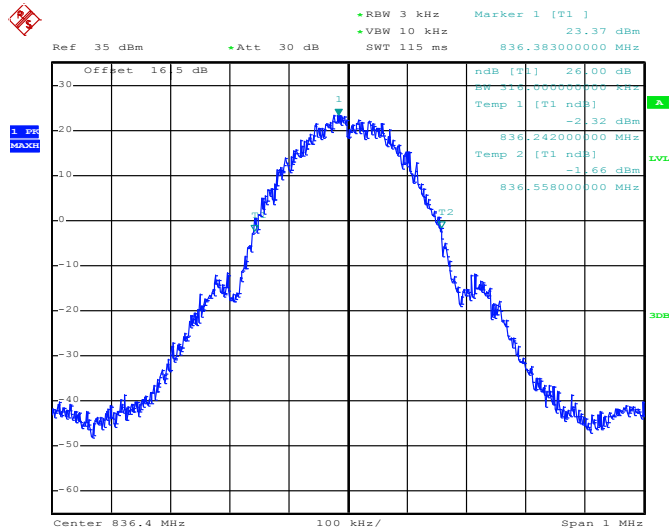

Date: 18.MAR.2015 14:08:22



99% Occupied Bandwidth Plot on Channel 251 (848.8 MHz)

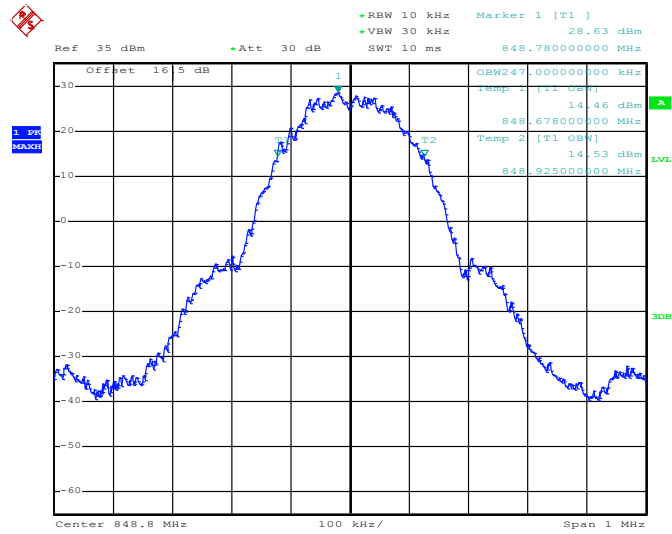

Date: 18.MAR.2015 14:10:46

26dB Bandwidth Plot on Channel 251 (848.8 MHz)

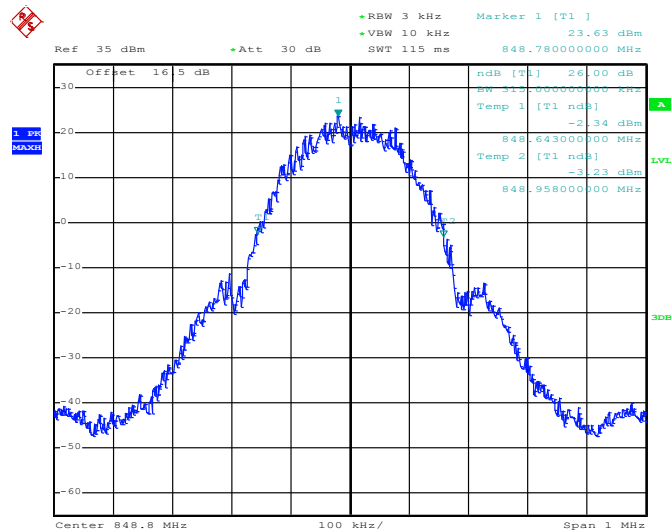

Date: 18.MAR.2015 14:08:57



Band :	GSM 850	Test Mode :	EDGE class 8 Link (8PSK)
---------------	---------	--------------------	--------------------------

99% Occupied Bandwidth Plot on Channel 128 (824.2 MHz)

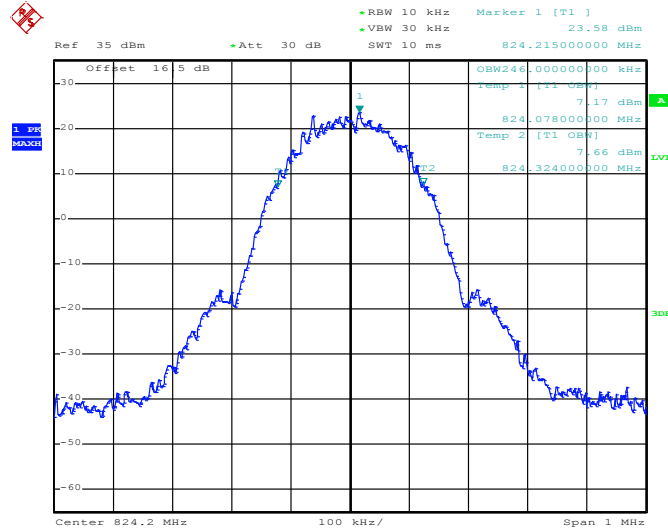

Date: 18.MAR.2015 14:22:32

26dB Bandwidth Plot on Channel 128 (824.2 MHz)

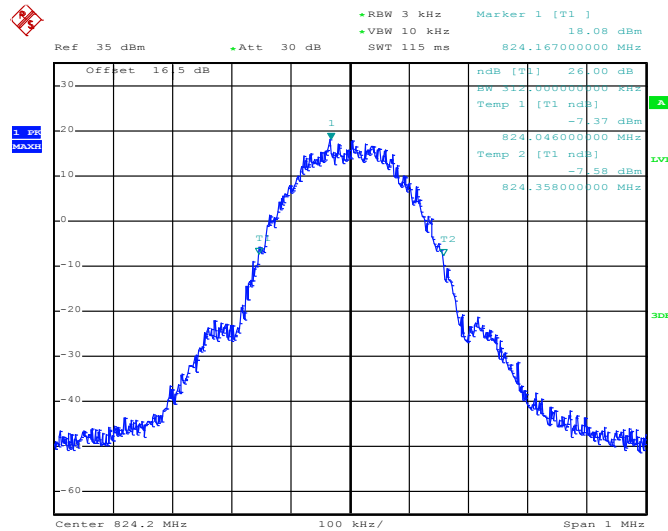

Date: 18.MAR.2015 14:19:22



99% Occupied Bandwidth Plot on Channel 189 (836.4 MHz)

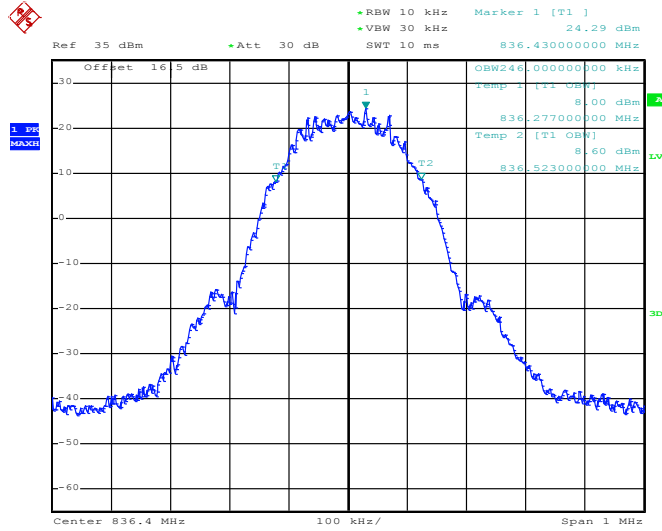

Date: 18.MAR.2015 14:23:07

26dB Bandwidth Plot on Channel 189 (836.4 MHz)

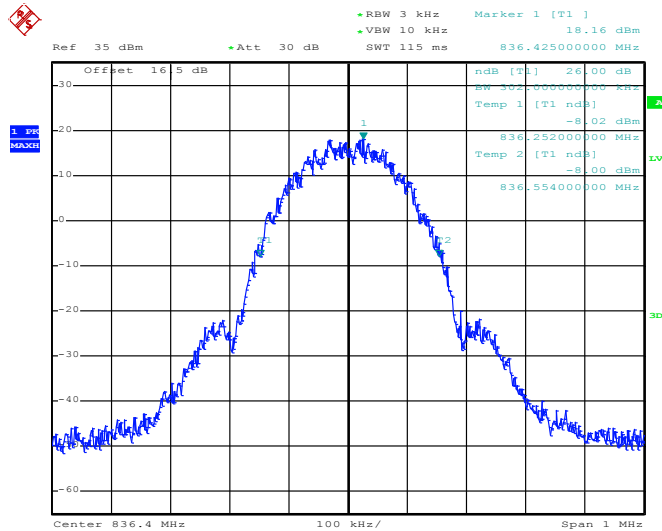

Date: 18.MAR.2015 14:20:17



99% Occupied Bandwidth Plot on Channel 251 (848.8 MHz)

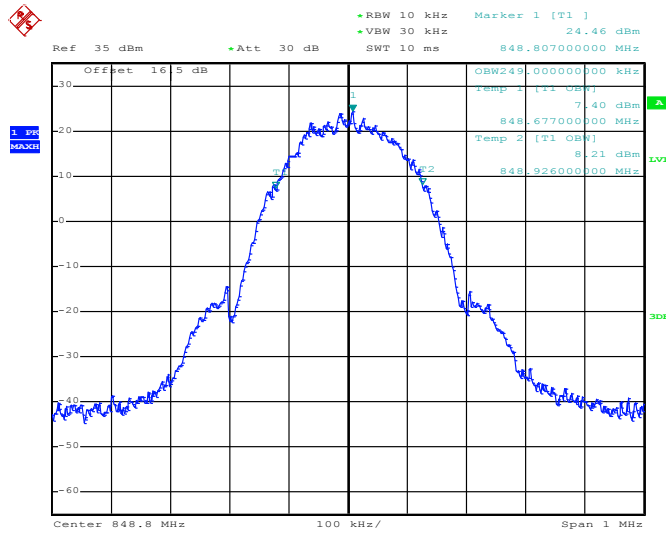

Date: 18.MAR.2015 14:24:12

26dB Bandwidth Plot on Channel 251 (848.8 MHz)

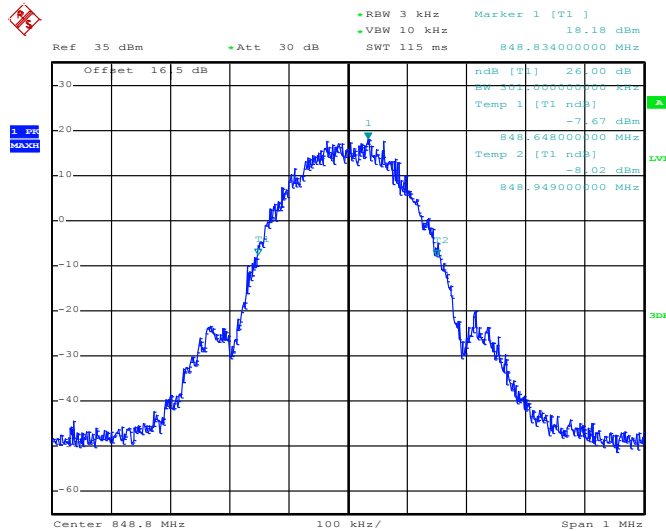

Date: 18.MAR.2015 14:20:50



Band :	GSM 1900	Test Mode :	GPRS class 8 Link (GMSK)
---------------	----------	--------------------	--------------------------

99% Occupied Bandwidth Plot on Channel 512 (1850.2 MHz)

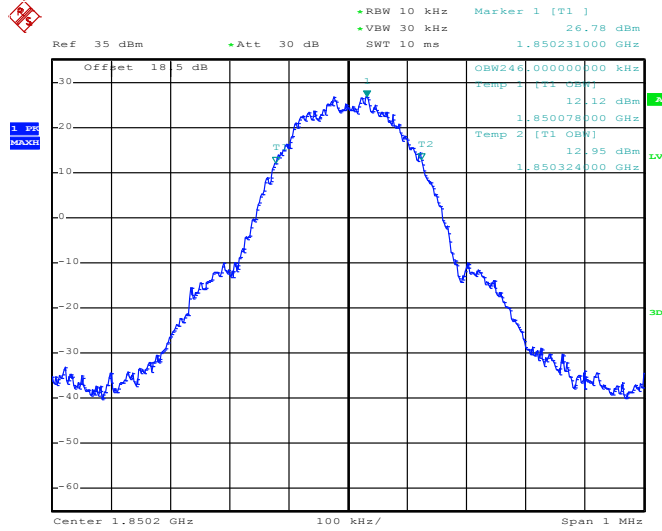

Date: 18.MAR.2015 14:59:34

26dB Bandwidth Plot on Channel 512 (1850.2 MHz)

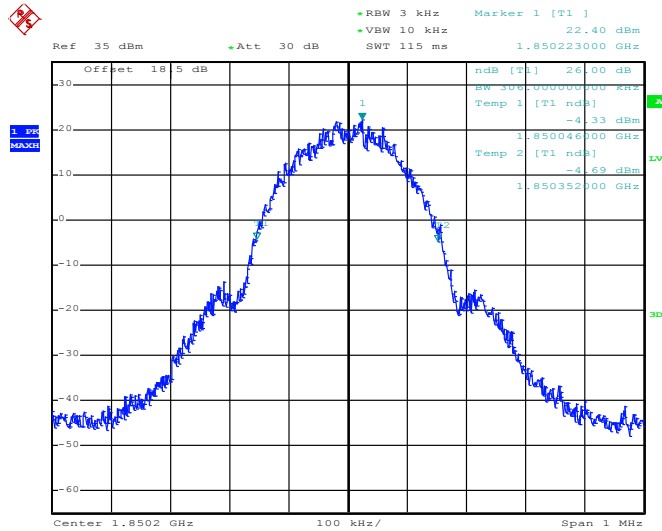

Date: 18.MAR.2015 14:56:26



99% Occupied Bandwidth Plot on Channel 661 (1880.0 MHz)

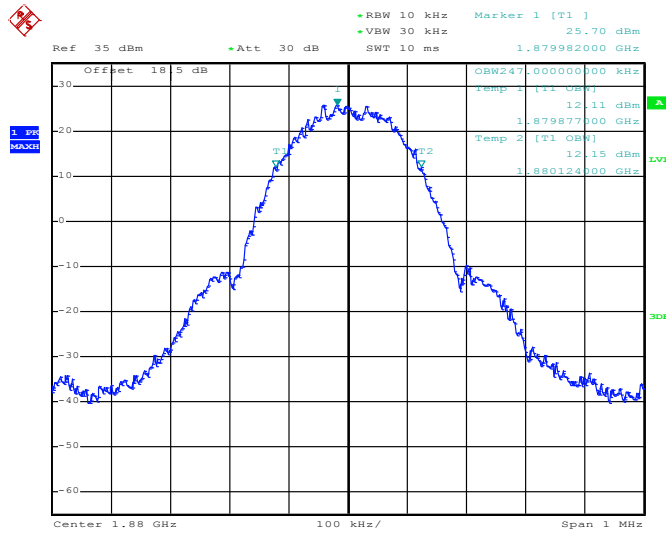

Date: 18.MAR.2015 15:00:59

26dB Bandwidth Plot on Channel 661 (1880.0 MHz)

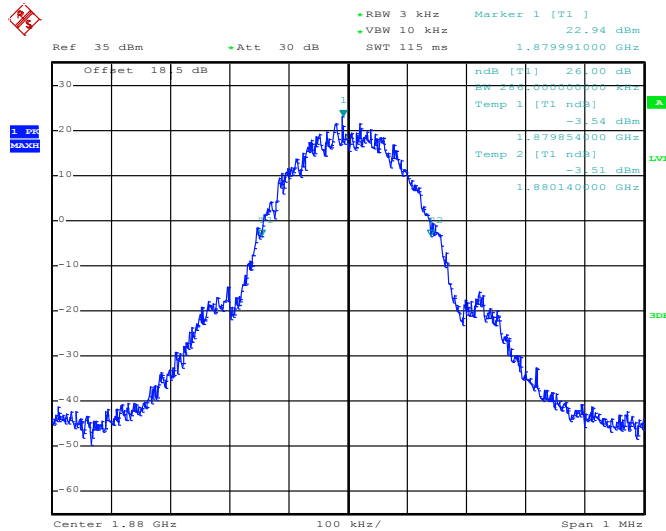

Date: 18.MAR.2015 14:57:00



99% Occupied Bandwidth Plot on Channel 810 (1909.8 MHz)

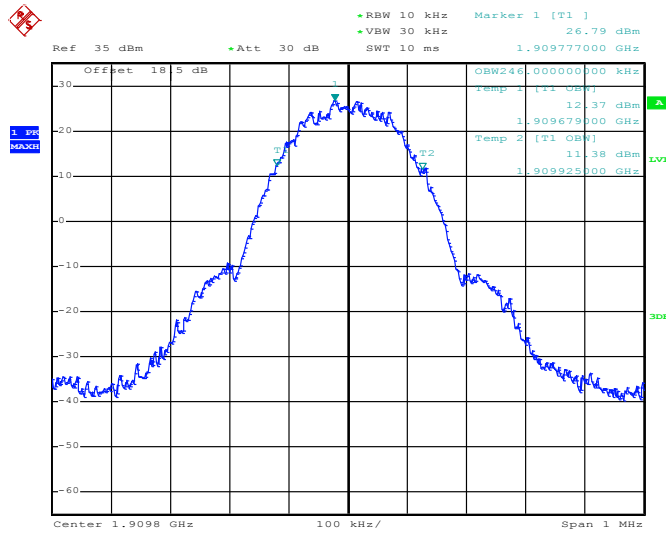

Date: 18.MAR.2015 15:02:32

26dB Bandwidth Plot on Channel 810 (1909.8 MHz)

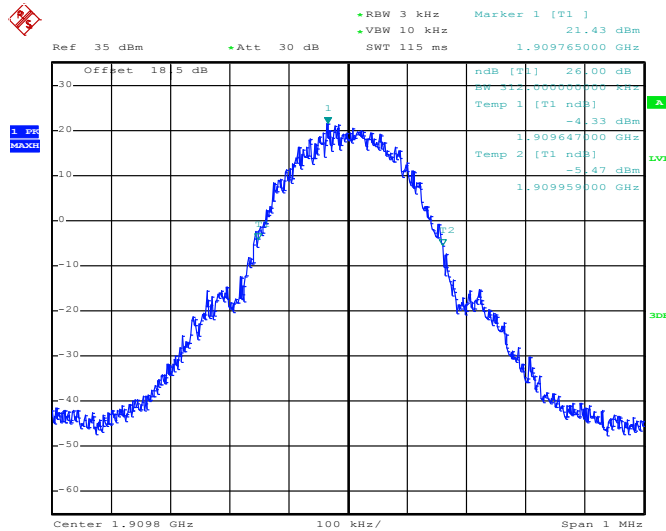

Date: 18.MAR.2015 14:58:06



Band :	GSM 1900	Test Mode :	EDGE class 8 Link (8PSK)
---------------	----------	--------------------	--------------------------

99% Occupied Bandwidth Plot on Channel 512 (1850.2 MHz)

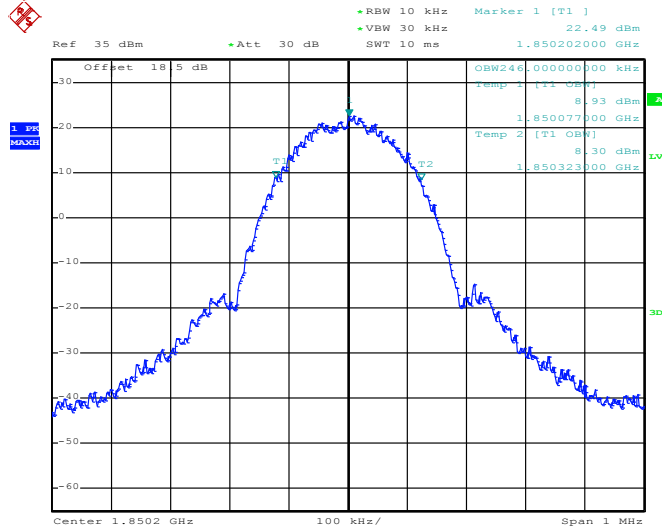

Date: 18.MAR.2015 15:24:14

26dB Bandwidth Plot on Channel 512 (1850.2 MHz)

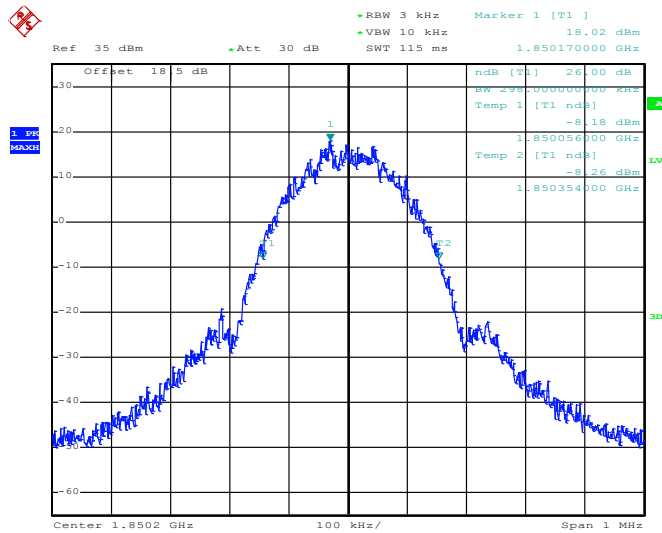

Date: 18.MAR.2015 15:17:00



99% Occupied Bandwidth Plot on Channel 661 (1880.0 MHz)

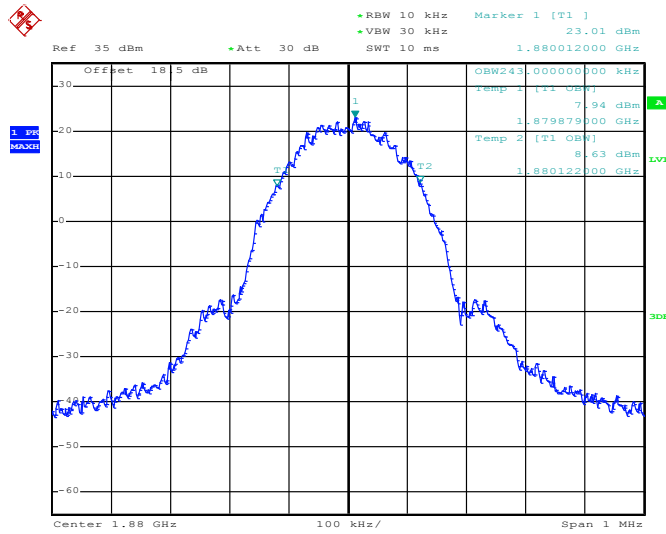

Date: 18.MAR.2015 15:24:56

26dB Bandwidth Plot on Channel 661 (1880.0 MHz)

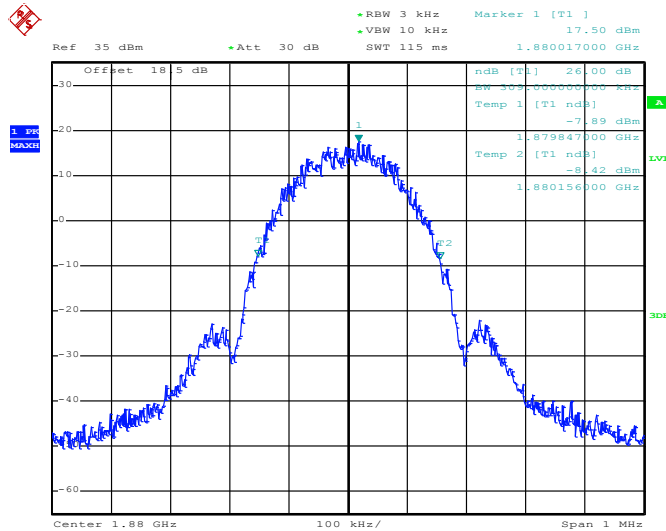

Date: 18.MAR.2015 15:17:55



99% Occupied Bandwidth Plot on Channel 810 (1909.8 MHz)

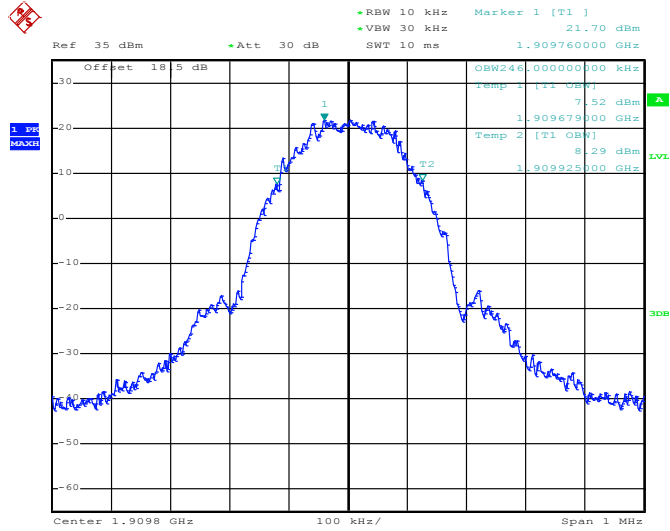

Date: 18.MAR.2015 15:25:38

26dB Bandwidth Plot on Channel 810 (1909.8 MHz)

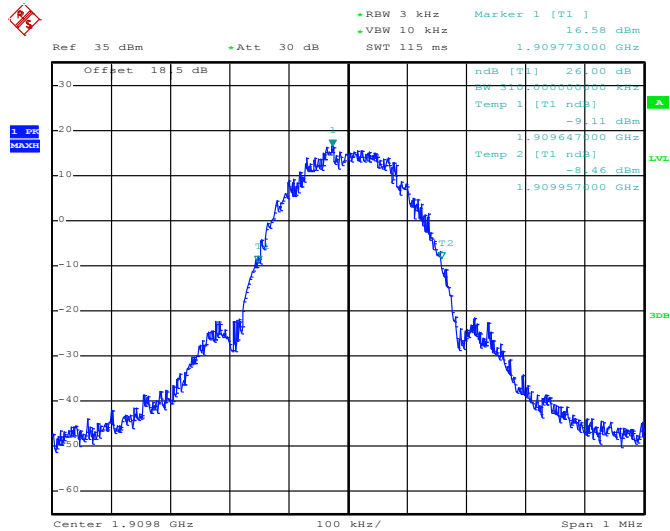

Date: 18.MAR.2015 15:19:13



Band :	WCDMA Band V	Test Mode :	RMC 12.2Kbps Link (QPSK)
---------------	--------------	--------------------	--------------------------

99% Occupied Bandwidth Plot on Channel 4132 (826.4 MHz)

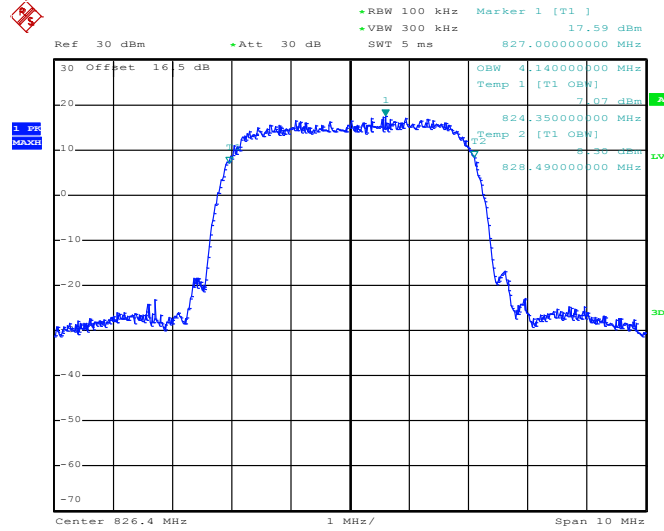

Date: 18.MAR.2015 14:43:04

26dB Bandwidth Plot on Channel 4132 (826.4 MHz)

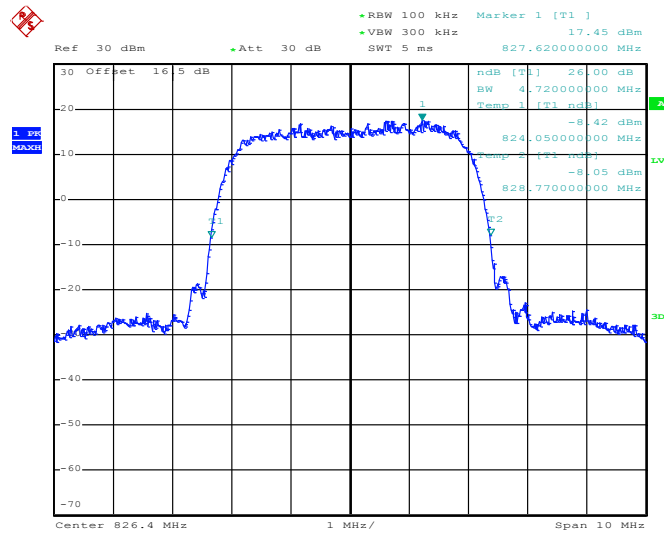

Date: 18.MAR.2015 14:40:21



99% Occupied Bandwidth Plot on Channel 4182 (836.4 MHz)

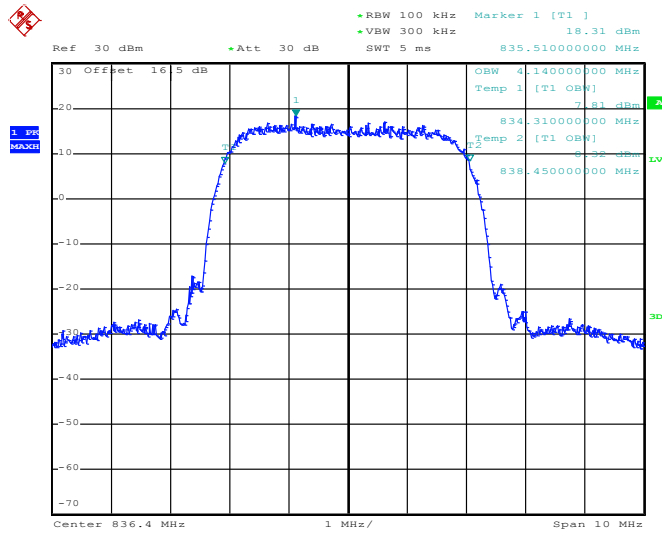

Date: 18.MAR.2015 14:43:32

26dB Bandwidth Plot on Channel 4182 (836.4 MHz)

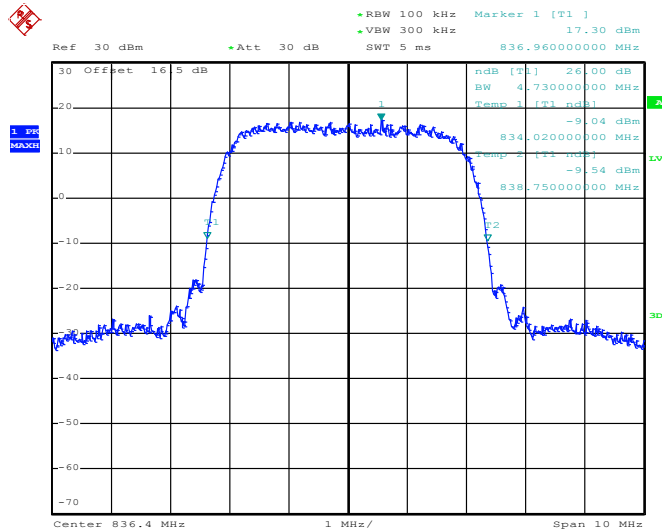

Date: 18.MAR.2015 14:40:49



99% Occupied Bandwidth Plot on Channel 4233 (846.6 MHz)

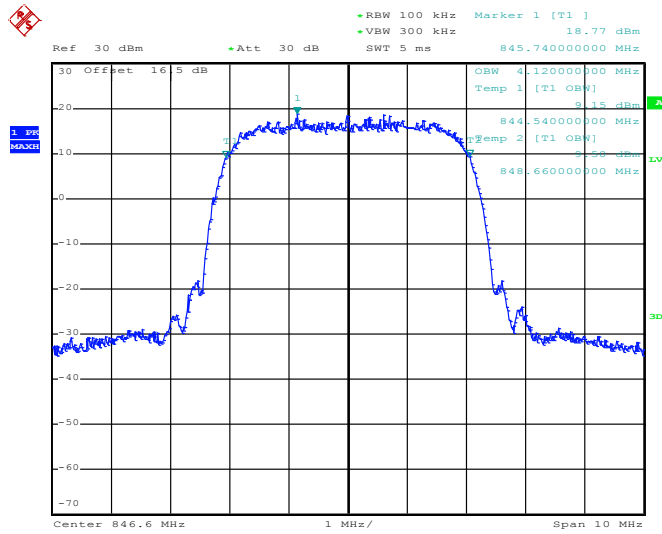

Date: 18.MAR.2015 14:44:00

26dB Bandwidth Plot on Channel 4233 (846.6 MHz)

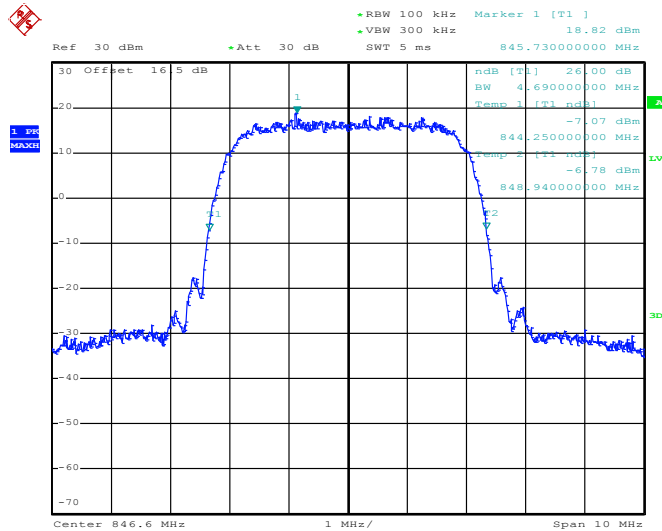

Date: 18.MAR.2015 14:41:17



Band :	WCDMA Band IV	Test Mode :	RMC 12.2Kbps Link (QPSK)
---------------	---------------	--------------------	--------------------------

99% Occupied Bandwidth Plot on Channel 1312 (1712.4 MHz)

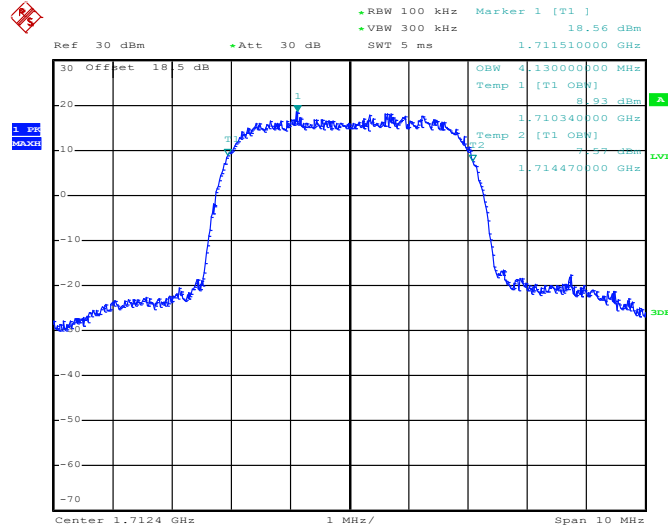

Date: 30.MAR.2015 10:26:17

26dB Bandwidth Plot on Channel 1312 (1712.4 MHz)

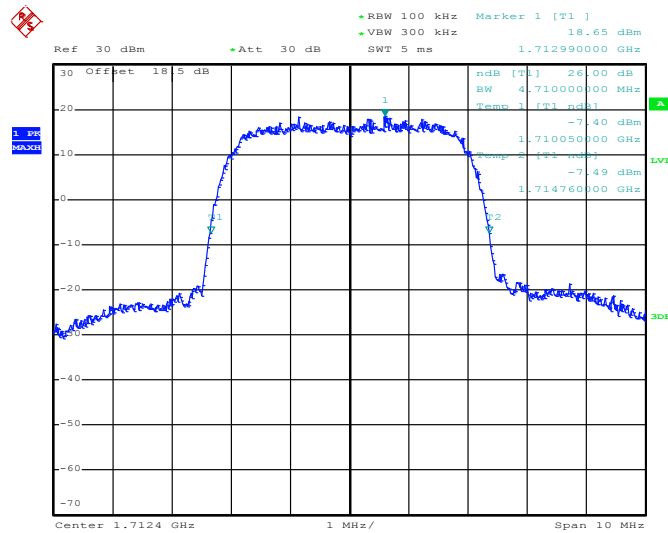

Date: 30.MAR.2015 10:23:23



99% Occupied Bandwidth Plot on Channel 1413 (1732.6 MHz)

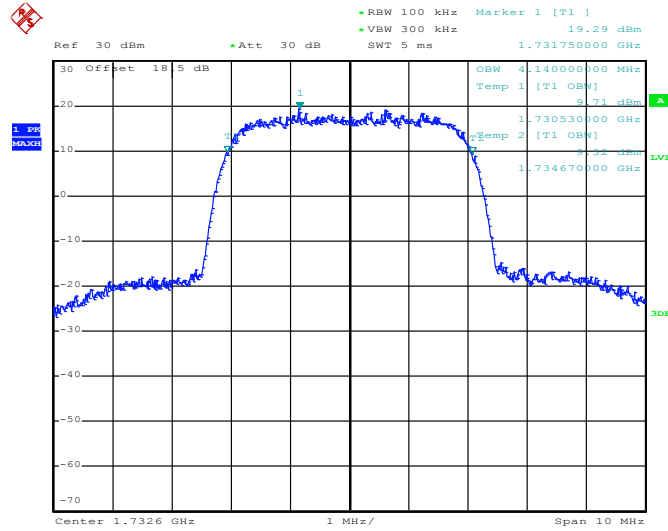

Date: 30.MAR.2015 10:26:55

26dB Bandwidth Plot on Channel 1413 (1732.6 MHz)

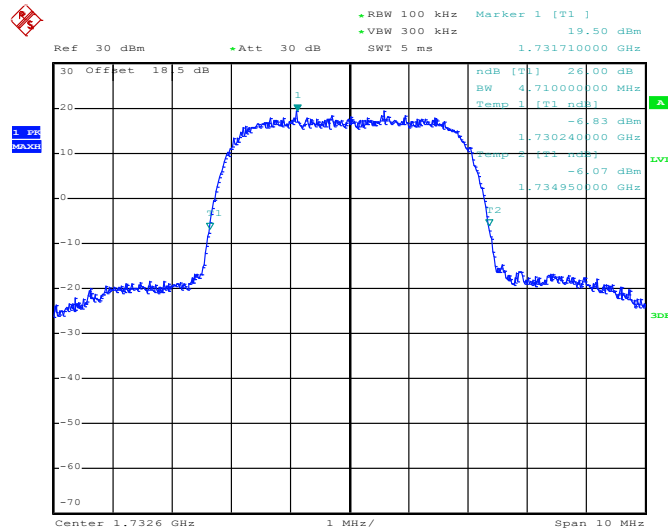

Date: 30.MAR.2015 10:24:15



99% Occupied Bandwidth Plot on Channel 1513 (1752.6 MHz)

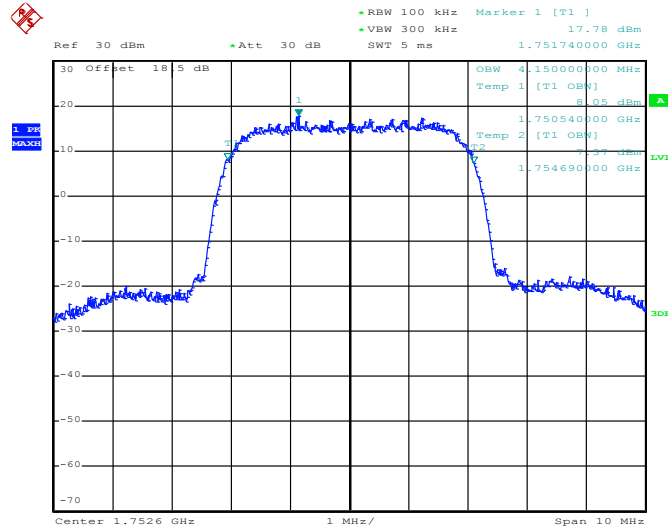

Date: 30.MAR.2015 10:27:35

26dB Bandwidth Plot on Channel 1513 (1752.6 MHz)

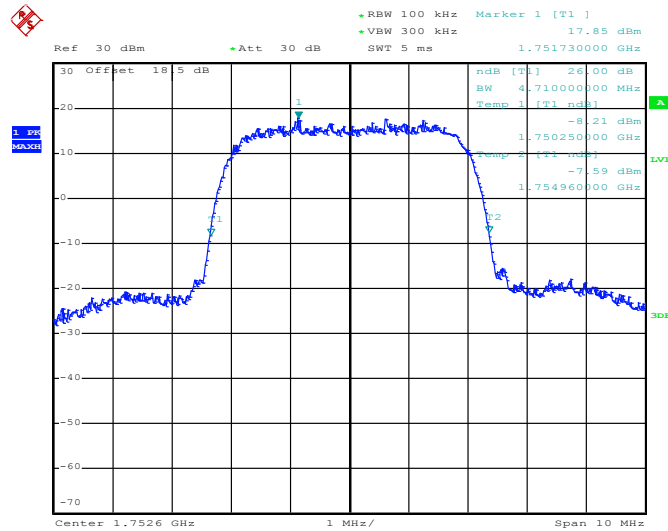

Date: 30.MAR.2015 10:25:12



Band :	WCDMA Band II	Test Mode :	RMC 12.2Kbps Link (QPSK)
---------------	---------------	--------------------	--------------------------

99% Occupied Bandwidth Plot on Channel 9262 (1852.4 MHz)

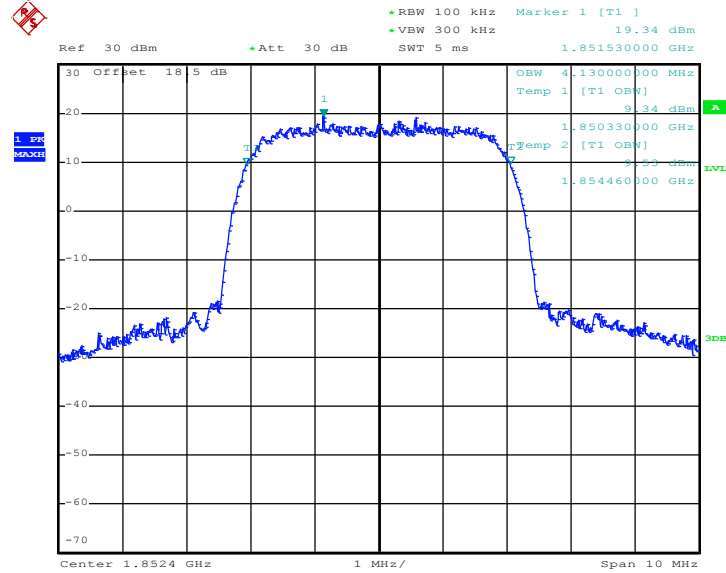

Date: 18.MAR.2015 15:43:24

26dB Bandwidth Plot on Channel 9262 (1852.4 MHz)

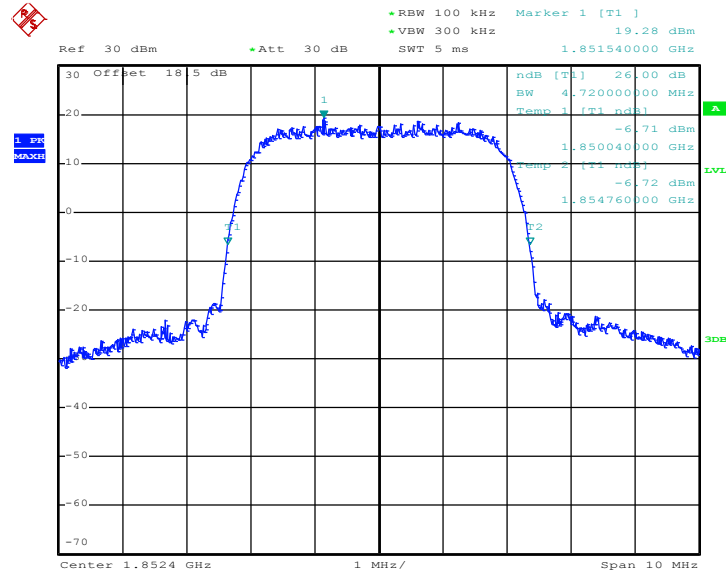

Date: 18.MAR.2015 15:41:46



99% Occupied Bandwidth Plot on Channel 9538 (1907.6 MHz)

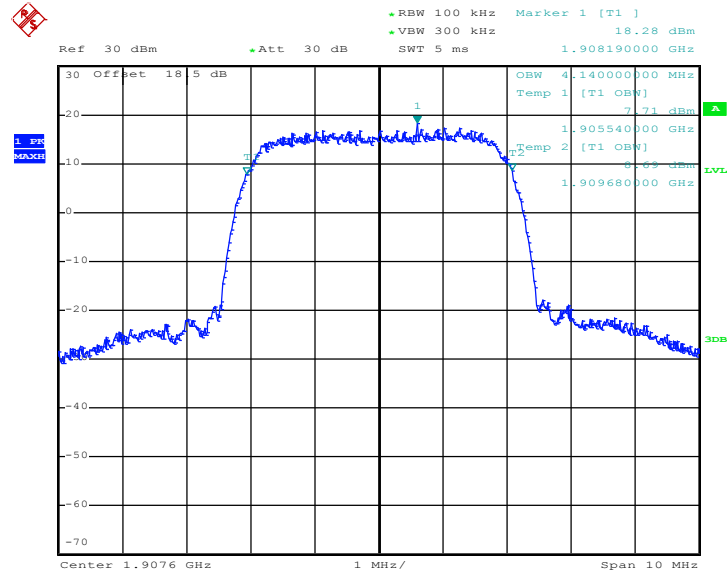

Date: 18.MAR.2015 15:44:20

26dB Bandwidth Plot on Channel 9538 (1907.6 MHz)

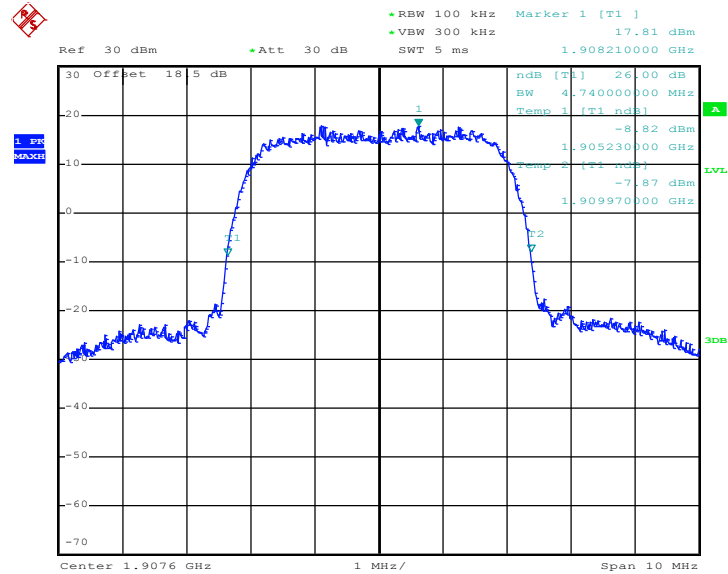

Date: 18.MAR.2015 15:42:42

3.4 Band Edge Measurement

3.4.1 Description of Band Edge Measurement

The power of any emission outside of the authorized operating frequency ranges must be lower than the transmitter power (P) by a factor of at least $43 + 10 \log (P)$ dB.

3.4.2 Measuring Instruments

The measuring equipment is listed in the section 4 of this test report.

3.4.3 Test Procedures

1. The testing follows FCC KDB 971168 v02r02 Section 6.0.
2. The EUT was connected to the spectrum analyzer and system simulator via a power divider.
3. The RF output of EUT was connected to the spectrum analyzer by an RF cable and attenuator. The path loss was compensated to the results for each measurement.
4. The band edges of low and high channels for the highest RF powers were measured.
5. The RF fundamental frequency should be excluded against the limit line in the operating frequency band.
6. The limit line is derived from $43 + 10\log(P)$ dB below the transmitter power P(Watts)
 $= P(W) - [43 + 10\log(P)] \text{ (dB)}$
 $= [30 + 10\log(P)] \text{ (dBm)} - [43 + 10\log(P)] \text{ (dB)}$
 $= -13\text{dBm}.$

3.4.4 Test Setup

<Conducted Band Edge >

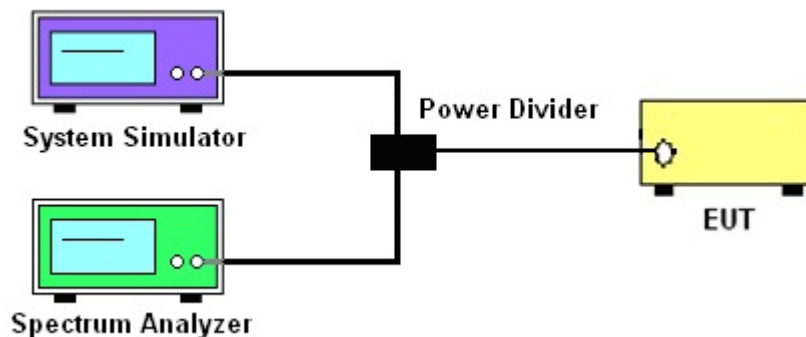



3.4.5 Test Result (Plots) of Conducted Band Edge

Band :	GSM850	Test Mode :	GPRS class 8 Link (GMSK)
--------	--------	-------------	--------------------------

Lower Band Edge Plot on Channel 128 (824.2 MHz)

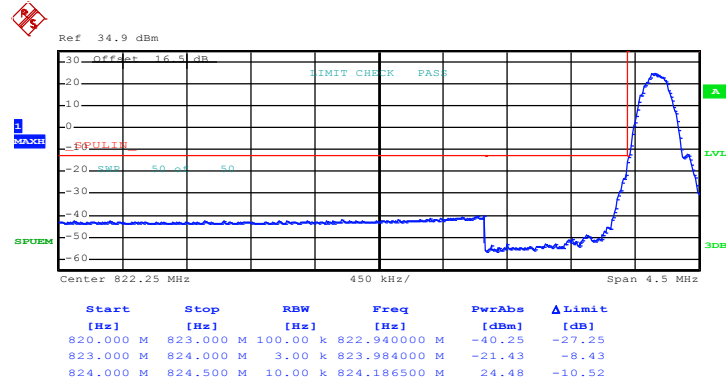

Date: 18.MAR.2015 14:12:17

Higher Band Edge Plot on Channel 251 (848.8 MHz)

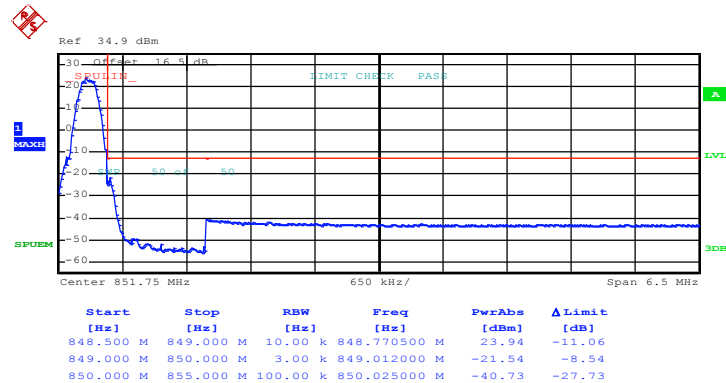

Date: 18.MAR.2015 14:13:35



Band :	GSM850	Test Mode :	EDGE class 8 Link (8PSK)
--------	--------	-------------	--------------------------

Lower Band Edge Plot on Channel 128 (824.2 MHz)

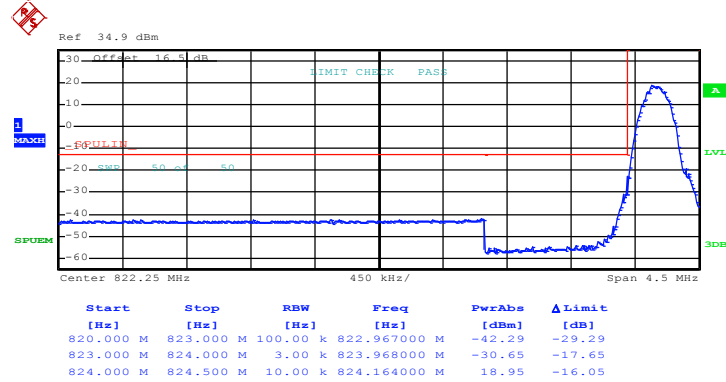

Date: 18.MAR.2015 14:25:59

Higher Band Edge Plot on Channel 251 (848.8 MHz)

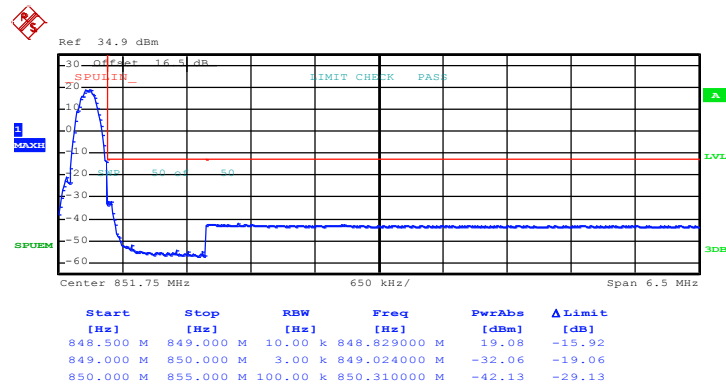

Date: 18.MAR.2015 14:27:22



Band :	GSM1900	Test Mode :	GPRS class 8 Link (GMSK)
---------------	---------	--------------------	--------------------------

Lower Band Edge Plot on Channel 512 (1850.2 MHz)

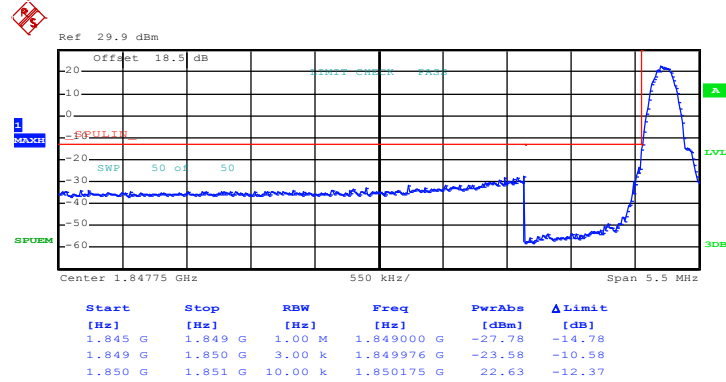

Date: 18.MAR.2015 15:04:27

Higher Band Edge Plot on Channel 810 (1909.8 MHz)

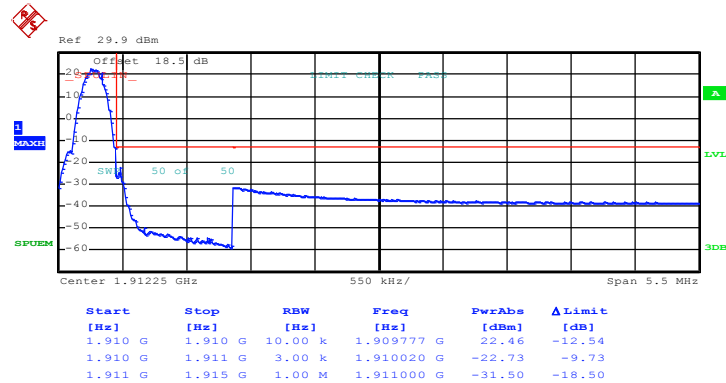

Date: 18.MAR.2015 15:06:12



Band :	GSM1900	Test Mode :	EDGE class 8 Link (8PSK)
--------	---------	-------------	--------------------------

Lower Band Edge Plot on Channel 512 (1850.2 MHz)

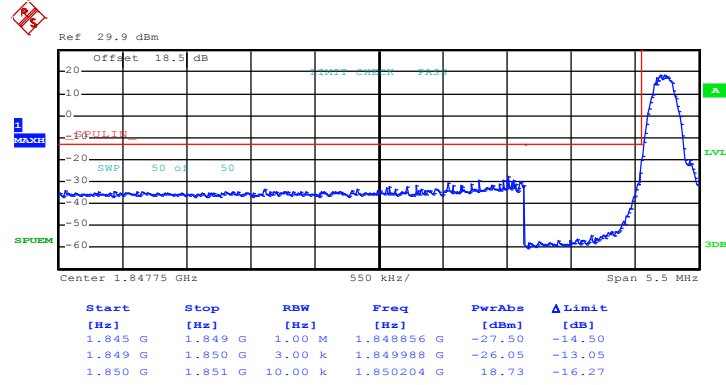

Date: 18.MAR.2015 15:27:15

Higher Band Edge Plot on Channel 810 (1909.8 MHz)

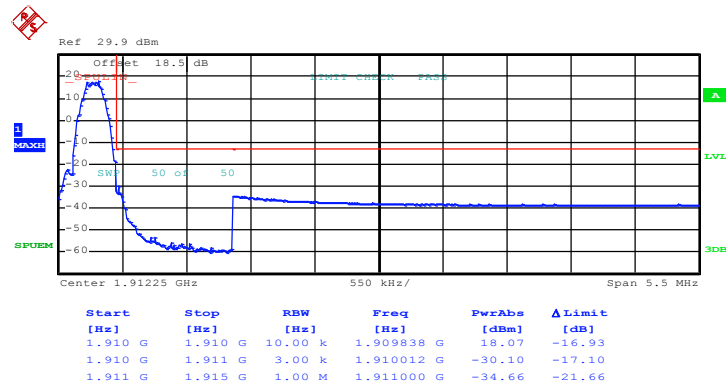

Date: 18.MAR.2015 15:28:34



Band :	WCDMA Band V	Test Mode :	RMC 12.2Kbps Link (QPSK)
--------	--------------	-------------	--------------------------

Lower Band Edge Plot on Channel 4132 (826.4 MHz)

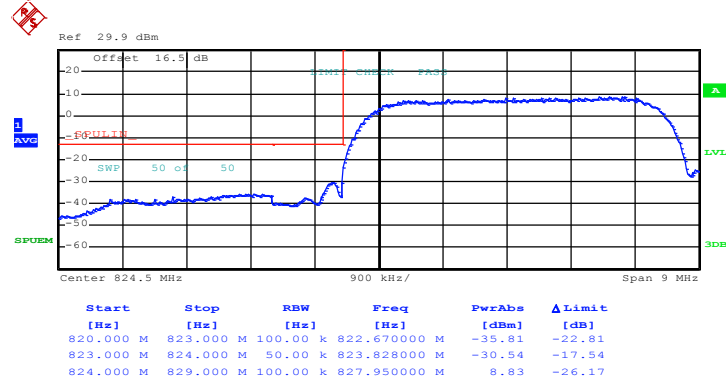

Date: 18.MAR.2015 14:46:41

Higher Band Edge Plot on Channel 4233 (846.6 MHz)

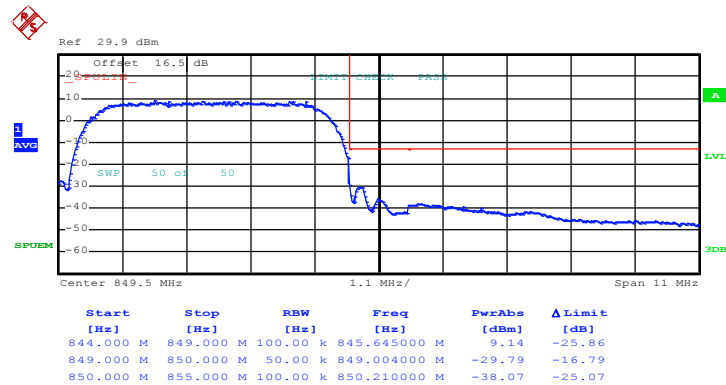

Date: 18.MAR.2015 14:47:53



Band :	WCDMA Band IV	Test Mode :	RMC 12.2Kbps Link (QPSK)
---------------	---------------	--------------------	--------------------------

Lower Band Edge Plot on Channel 1312 (1712.4 MHz)

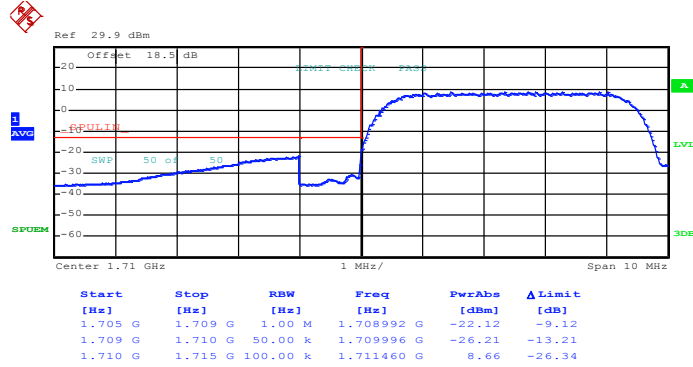

Date: 30.MAR.2015 10:29:17

Higher Band Edge Plot on Channel 1513 (1752.6 MHz)

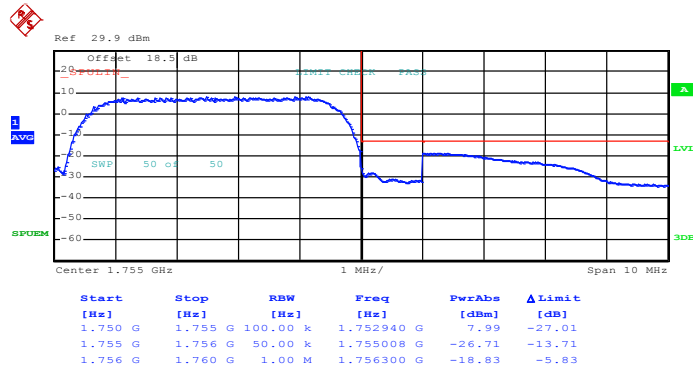

Date: 30.MAR.2015 10:30:41



Band :	WCDMA Band II	Test Mode :	RMC 12.2Kbps Link (QPSK)
---------------	---------------	--------------------	--------------------------

Lower Band Edge Plot on Channel 9262 (1852.4 MHz)

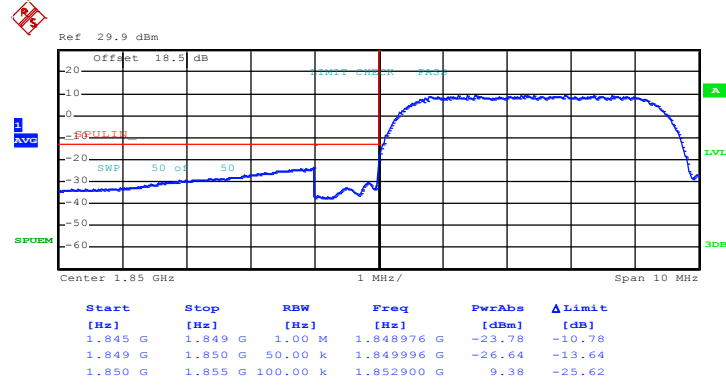

Date: 18.MAR.2015 15:45:39

Higher Band Edge Plot on Channel 9538 (1907.6 MHz)

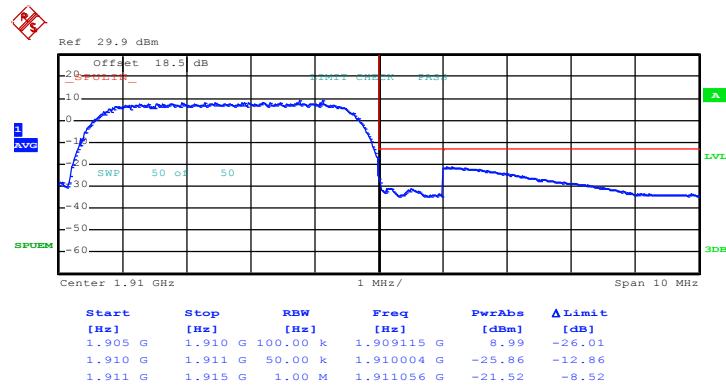

Date: 18.MAR.2015 15:46:51



3.5 Conducted Spurious Emission Measurement

3.5.1 Description of Conducted Spurious Emission Measurement

The power of any emission outside of the authorized operating frequency ranges must be lower than the transmitter power (P) by a factor of at least $43 + 10 \log (P)$ dB.

It is measured by means of a calibrated spectrum analyzer and scanned from 30 MHz up to a frequency including its 10th harmonic.

3.5.2 Measuring Instruments

The measuring equipment is listed in the section 4 of this test report.

3.5.3 Test Procedures

1. The testing follows FCC KDB 971168 v02r02 Section 6.0.
2. The EUT was connected to the spectrum analyzer and system simulator via a power divider.
3. The RF output of EUT was connected to the spectrum analyzer by an RF cable and attenuator. The path loss was compensated to the results for each measurement.
4. The middle channel for the highest RF power within the transmitting frequency was measured.
5. The conducted spurious emission for the whole frequency range was taken.
6. The RF fundamental frequency should be excluded against the limit line in the operating frequency band.
7. The limit line is derived from $43 + 10\log(P)$ dB below the transmitter power P(Watts)
= $P(W) - [43 + 10\log(P)]$ (dB)
= $[30 + 10\log(P)]$ (dBm) - $[43 + 10\log(P)]$ (dB)
= -13dBm.

3.5.4 Test Setup

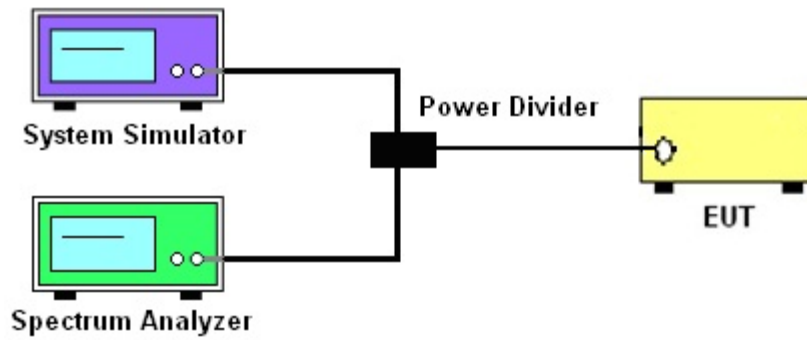



3.5.5 Test Result (Plots) of Conducted Spurious Emission

Band :	GSM850	Channel :	CH128
Test Mode :	GPRS class 8 Link (GMSK)	Frequency :	824.2 MHz

Conducted Spurious Emission Plot between 30MHz ~ 9GHz

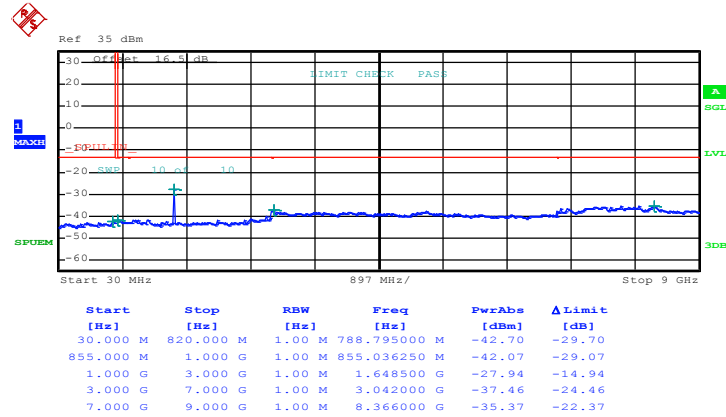

Date: 18.MAR.2015 14:14:34



Band :	GSM850	Channel :	CH189
Test Mode :	GPRS class 8 Link (GMSK)	Frequency :	836.4 MHz

Conducted Spurious Emission Plot between 30MHz ~ 9GHz

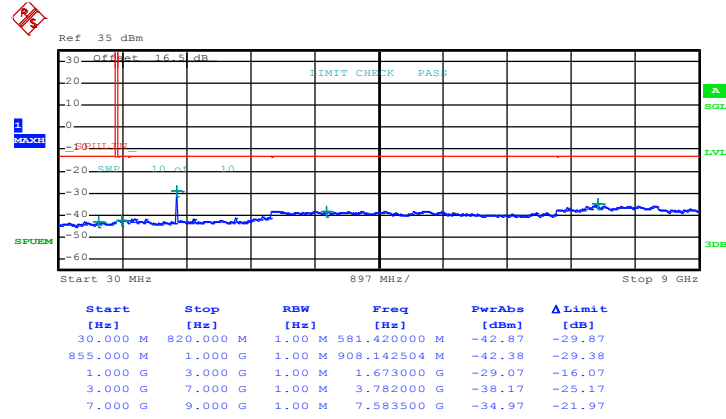

Date: 18.MAR.2015 14:15:04



Band :	GSM850	Channel :	CH251
Test Mode :	GPRS class 8 Link (GMSK)	Frequency :	848.8 MHz

Conducted Spurious Emission Plot between 30MHz ~ 9GHz

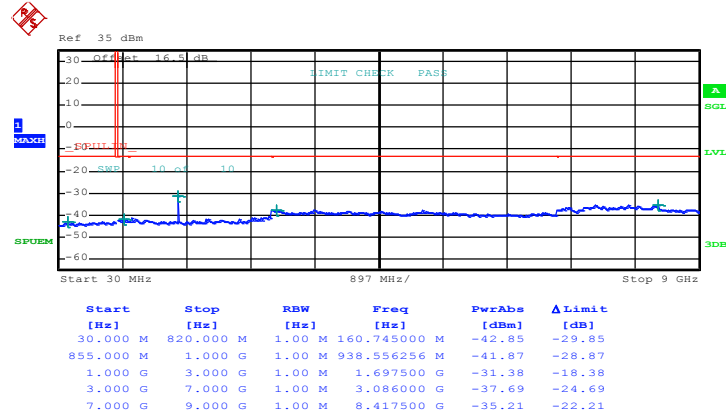

Date: 18.MAR.2015 14:15:37



Band :	GSM850	Channel :	CH128
Test Mode :	EDGE class 8 Link (8PSK)	Frequency :	824.2 MHz

Conducted Spurious Emission Plot between 30MHz ~ 9GHz

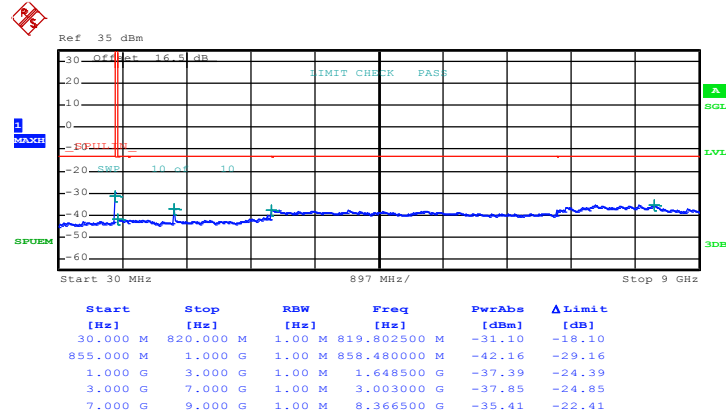

Date: 18.MAR.2015 14:28:27



Band :	GSM850	Channel :	CH189
Test Mode :	EDGE class 8 Link (8PSK)	Frequency :	836.4 MHz

Conducted Spurious Emission Plot between 30MHz ~ 9GHz

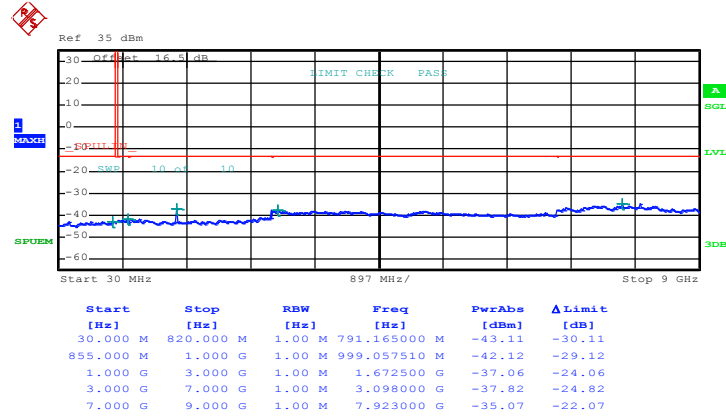

Date: 18.MAR.2015 14:29:39



Band :	GSM850	Channel :	CH251
Test Mode :	EDGE class 8 Link (8PSK)	Frequency :	848.8 MHz

Conducted Spurious Emission Plot between 30MHz ~ 9GHz

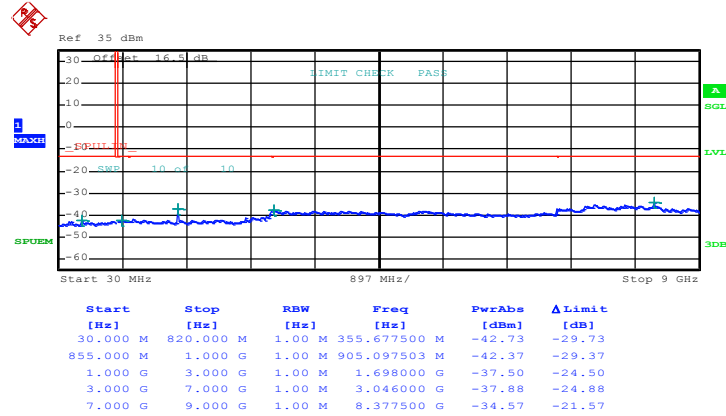

Date: 18.MAR.2015 14:30:48



Band :	GSM1900	Channel :	CH512
Test Mode :	GPRS class 8 Link (GMSK)	Frequency :	1850.2 MHz

Conducted Spurious Emission Plot between 30MHz ~ 19.1GHz

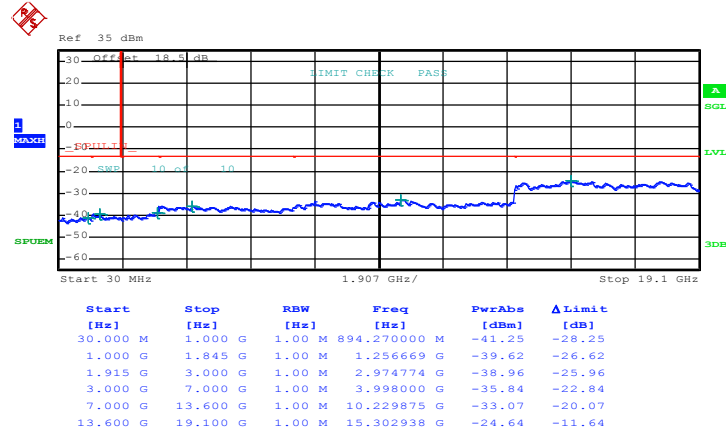

Date: 18.MAR.2015 15:11:59



Band :	GSM1900	Channel :	CH661
Test Mode :	GPRS class 8 Link (GMSK)	Frequency :	1880.0 MHz

Conducted Spurious Emission Plot between 30MHz ~ 19.1GHz

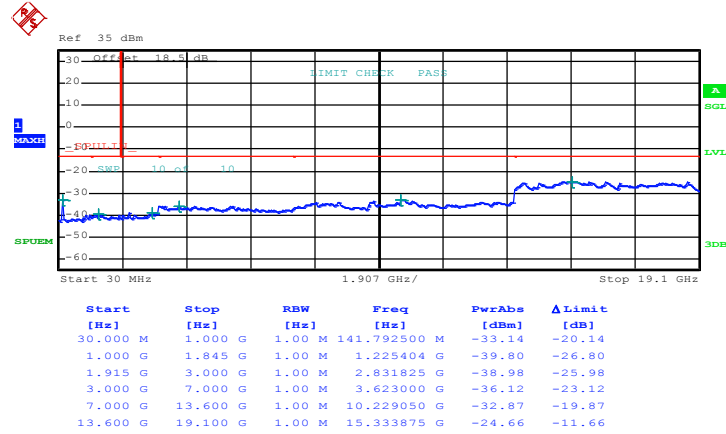

Date: 18.MAR.2015 15:12:32



Band :	GSM1900	Channel :	CH810
Test Mode :	GPRS class 8 Link (GMSK)	Frequency :	1909.8 MHz

Conducted Spurious Emission Plot between 30MHz ~ 19.1GHz

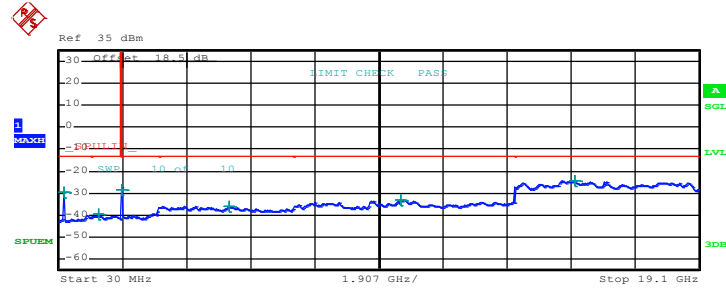

Start [Hz]	Stop [Hz]	RBW [Hz]	Freq [Hz]	PwrAbs [dBm]	Δ Limit [dB]
30.000 M	1.000 G	1.00 M	171.620000 M	-29.80	-16.80
1.000 G	1.845 G	1.00 M	1.230896 G	-39.82	-26.82
1.915 G	3.000 G	1.00 M	1.915271 G	-28.39	-15.39
3.000 G	7.000 G	1.00 M	5.111000 G	-36.04	-23.04
7.000 G	13.600 G	1.00 M	10.219975 G	-33.41	-20.41
13.600 G	19.100 G	1.00 M	15.401250 G	-24.48	-11.48

Date: 18.MAR.2015 15:13:05



Band :	GSM1900	Channel :	CH512
Test Mode :	EDGE class 8 Link (8PSK)	Frequency :	1850.2 MHz

Conducted Spurious Emission Plot between 30MHz ~ 19.1GHz

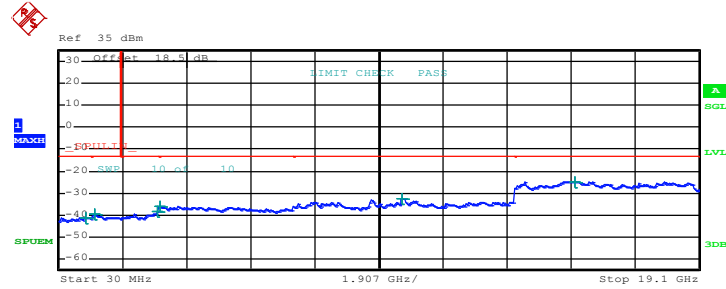

Start [Hz]	Stop [Hz]	RBW [Hz]	Freq [Hz]	PwrAbs [dBm]	Δ Limit [dB]
30.000 M	1.000 G	1.00 M	844.315000 M	-41.10	-28.10
1.000 G	1.845 G	1.00 M	1.104146 G	-39.79	-26.79
1.915 G	3.000 G	1.00 M	2.962296 G	-38.25	-25.25
3.000 G	7.000 G	1.00 M	3.039000 G	-35.84	-22.84
7.000 G	13.600 G	1.00 M	10.243900 G	-32.74	-19.74
13.600 G	19.100 G	1.00 M	15.405375 G	-24.67	-11.67

Date: 18.MAR.2015 15:33:40



Band :	GSM1900	Channel :	CH661
Test Mode :	EDGE class 8 Link (8PSK)	Frequency :	1880.0 MHz

Conducted Spurious Emission Plot between 30MHz ~ 19.1GHz

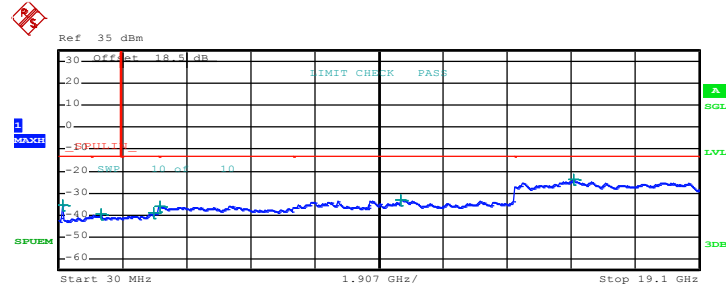

Start [Hz]	Stop [Hz]	RBW [Hz]	Freq [Hz]	PwrAbs [dBm]	Δ Limit [dB]
30.000 M	1.000 G	1.00 M	141.792500 M	-35.70	-22.70
1.000 G	1.845 G	1.00 M	1.275893 G	-39.82	-26.82
1.915 G	3.000 G	1.00 M	2.862205 G	-39.04	-26.04
3.000 G	7.000 G	1.00 M	3.036000 G	-36.08	-23.08
7.000 G	13.600 G	1.00 M	10.222450 G	-32.91	-19.91
13.600 G	19.100 G	1.00 M	15.377188 G	-24.06	-11.06

Date: 18.MAR.2015 15:34:09



Band :	GSM1900	Channel :	CH810
Test Mode :	EDGE class 8 Link (8PSK)	Frequency :	1909.8 MHz

Conducted Spurious Emission Plot between 30MHz ~ 19.1GHz

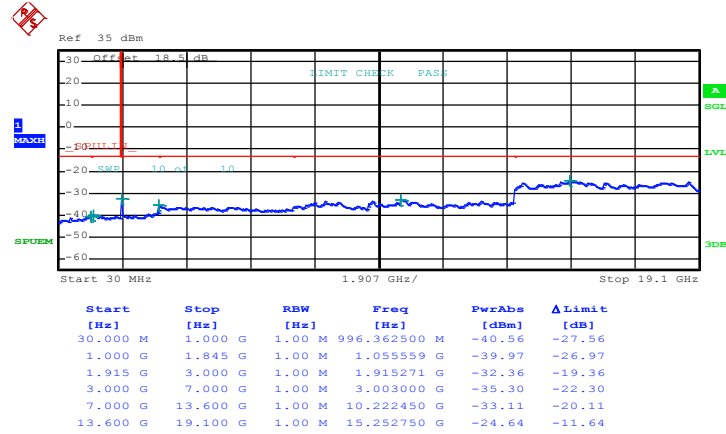

Date: 18.MAR.2015 15:34:40



Band :	WCDMA Band V	Channel :	CH4132
Test Mode :	RMC 12.2Kbps Link (QPSK)	Frequency :	826.4 MHz

Conducted Spurious Emission Plot between 30MHz ~ 9GHz

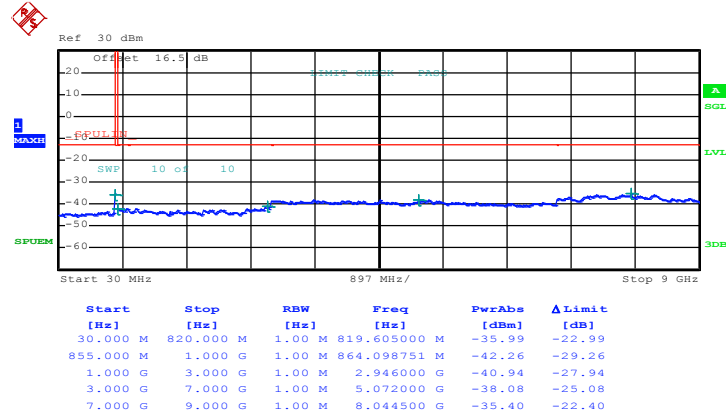

Date: 18.MAR.2015 14:48:50



Band :	WCDMA Band V	Channel :	CH4182
Test Mode :	RMC 12.2Kbps Link (QPSK)	Frequency :	836.4 MHz

Conducted Spurious Emission Plot between 30MHz ~ 9GHz

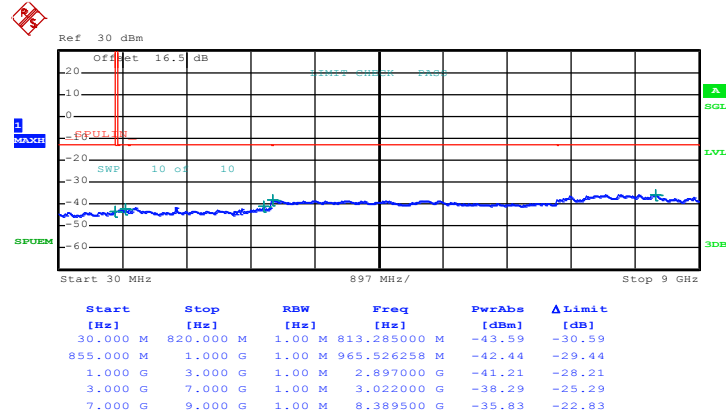

Date: 18.MAR.2015 14:49:15



Band :	WCDMA Band V	Channel :	CH4233
Test Mode :	RMC 12.2Kbps Link (QPSK)	Frequency :	846.6 MHz

Conducted Spurious Emission Plot between 30MHz ~ 9GHz

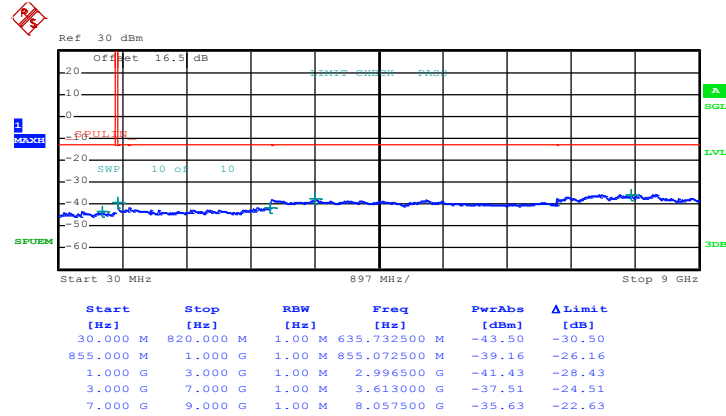

Date: 18.MAR.2015 14:49:40



Band :	WCDMA Band IV	Channel :	CH1312
Test Mode :	RMC 12.2Kbps Link (QPSK)	Frequency :	1712.4 MHz

Conducted Spurious Emission Plot between 30MHz ~ 18GHz

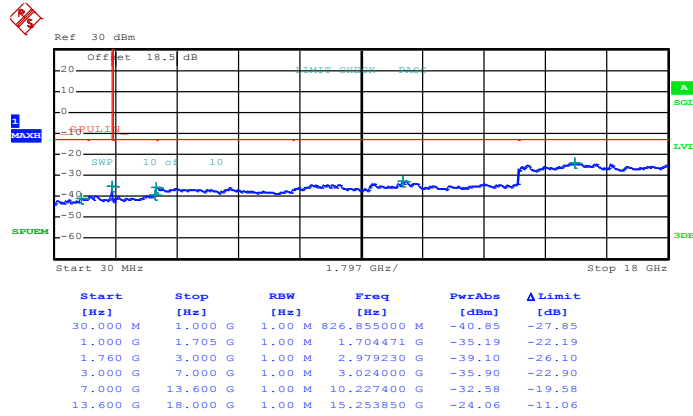

Date: 30.MAR.2015 10:31:20



Band :	WCDMA Band IV	Channel :	CH1413
Test Mode :	RMC 12.2Kbps Link (QPSK)	Frequency :	1732.6 MHz

Conducted Spurious Emission Plot between 30MHz ~ 18GHz

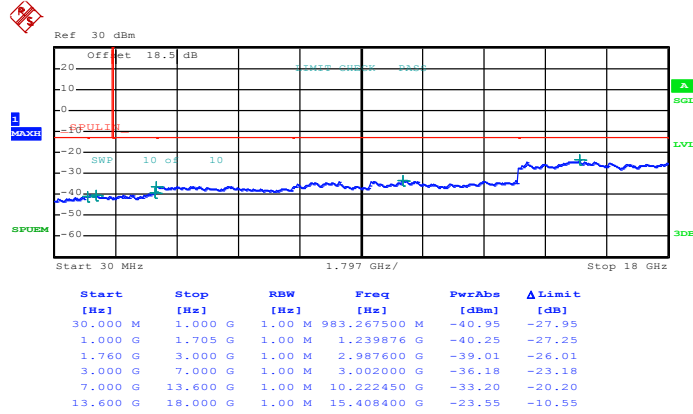

Date: 30.MAR.2015 10:31:56



Band :	WCDMA Band IV	Channel :	CH1513
Test Mode :	RMC 12.2Kbps Link (QPSK)	Frequency :	1752.6 MHz

Conducted Spurious Emission Plot between 30MHz ~ 18GHz

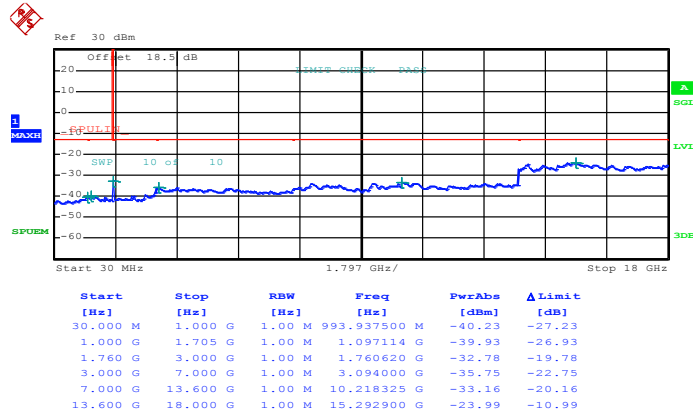

Date: 30.MAR.2015 10:32:34



Band :	WCDMA Band II	Channel :	CH9262
Test Mode :	RMC 12.2Kbps Link (QPSK)	Frequency :	1852.4 MHz

Conducted Spurious Emission Plot between 30MHz ~ 19.1GHz

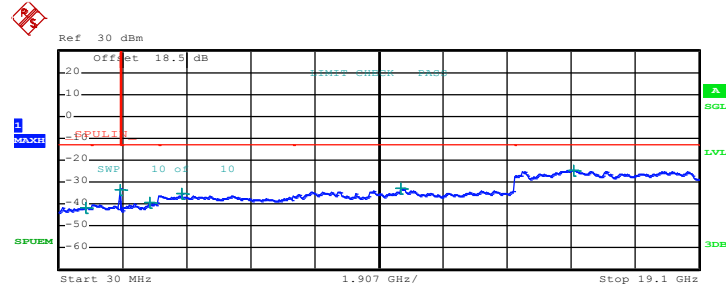

Start [Hz]	Stop [Hz]	RBW [Hz]	Freq [Hz]	PwrAbs [dBm]	Δ Limit [dB]
30.000 M	1.000 G	1.00 M	840.677500 M	-41.41	-28.41
1.000 G	1.845 G	1.00 M	1.844366 G	-33.73	-20.73
1.915 G	3.000 G	1.00 M	2.730649 G	-39.23	-26.23
3.000 G	7.000 G	1.00 M	3.703000 G	-35.31	-22.31
7.000 G	13.600 G	1.00 M	10.215025 G	-33.05	-20.05
13.600 G	19.100 G	1.00 M	15.381313 G	-24.62	-11.62

Date: 18.MAR.2015 15:49:35



Band :	WCDMA Band II	Channel :	CH9400
Test Mode :	RMC 12.2Kbps Link (QPSK)	Frequency :	1880.0 MHz

Conducted Spurious Emission Plot between 30MHz ~ 19.1GHz

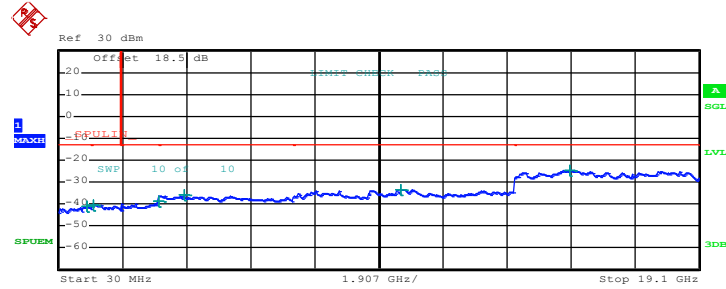

Start [Hz]	Stop [Hz]	RBW [Hz]	Freq [Hz]	PwrAbs [dBm]	Δ Limit [dB]
30.000 M	1.000 G	1.00 M	863.230000 M	-41.06	-28.06
1.000 G	1.845 G	1.00 M	1.041827 G	-40.26	-27.26
1.915 G	3.000 G	1.00 M	2.996745 G	-38.86	-25.86
3.000 G	7.000 G	1.00 M	3.759000 G	-35.81	-22.81
7.000 G	13.600 G	1.00 M	10.210075 G	-33.33	-20.33
13.600 G	19.100 G	1.00 M	15.243125 G	-24.39	-11.39

Date: 18.MAR.2015 15:50:00



Band :	WCDMA Band II	Channel :	CH9538
Test Mode :	RMC 12.2Kbps Link (QPSK)	Frequency :	1907.6 MHz

Conducted Spurious Emission Plot between 30MHz ~ 19.1GHz

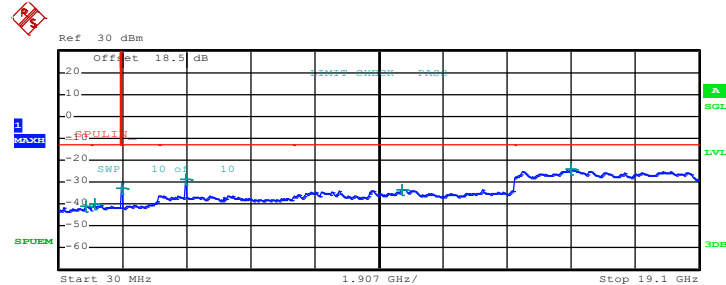

Start [Hz]	Stop [Hz]	RBW [Hz]	Freq [Hz]	PwrAbs [dBm]	Δ Limit [dB]
30.000 M	1.000 G	1.00 M	815.942500 M	-41.26	-28.26
1.000 G	1.845 G	1.00 M	1.104146 G	-39.83	-26.83
1.915 G	3.000 G	1.00 M	1.915542 G	-32.96	-19.96
3.000 G	7.000 G	1.00 M	3.816000 G	-28.89	-15.89
7.000 G	13.600 G	1.00 M	10.261225 G	-33.37	-20.37
13.600 G	19.100 G	1.00 M	15.304313 G	-24.27	-11.27

Date: 18.MAR.2015 15:50:26



3.6 Field Strength of Spurious Radiation Measurement

3.6.1 Description of Field Strength of Spurious Radiated Measurement

The power of any emission outside of the authorized operating frequency ranges must be attenuated below the transmitter power (P) by a factor of at least $43 + 10 \log (P)$ dB. The spectrum is scanned from 30 MHz up to a frequency including its 10th harmonic.

3.6.2 Measuring Instruments

The measuring equipment is listed in the section 4 of this test report.

3.6.3 Test Procedures

1. The testing follows FCC KDB 971168 v02r02 Section 5.8 and ANSI / TIA-603-C-2004 Section 2.2.12.
2. The EUT was placed on a rotatable wooden table 0.8 meters above the ground.
3. The EUT was set 3 meters from the receiving antenna, which was mounted on the antenna tower.
4. The table was rotated 360 degrees to determine the position of the highest spurious emission.
5. The height of the receiving antenna is varied between one meter and four meters to search for the maximum spurious emission for both horizontal and vertical polarizations.
6. Make the measurement with the spectrum analyzer's RBW = 1MHz, VBW = 3MHz, taking record of maximum spurious emission.
7. A horn antenna was substituted in place of the EUT and was driven by a signal generator.
8. Tune the output power of signal generator to the same emission level with EUT maximum spurious emission.
9. Taking the record of output power at antenna port.
10. Repeat step 7 to step 8 for another polarization.
11. $EIRP \text{ (dBm)} = S.G. \text{ Power} - Tx \text{ Cable Loss} + Tx \text{ Antenna Gain}$
12. $ERP \text{ (dBm)} = EIRP - 2.15$
13. The RF fundamental frequency should be excluded against the limit line in the operating frequency band.
14. The limit line is derived from $43 + 10\log(P)$ dB below the transmitter power P(Watts)
 $= P(W) - [43 + 10\log(P)] \text{ (dB)}$
 $= [30 + 10\log(P)] \text{ (dBm)} - [43 + 10\log(P)] \text{ (dB)}$
 $= -13dBm.$

3.6.4 Test Setup

For radiated emissions from 30MHz to 1GHz

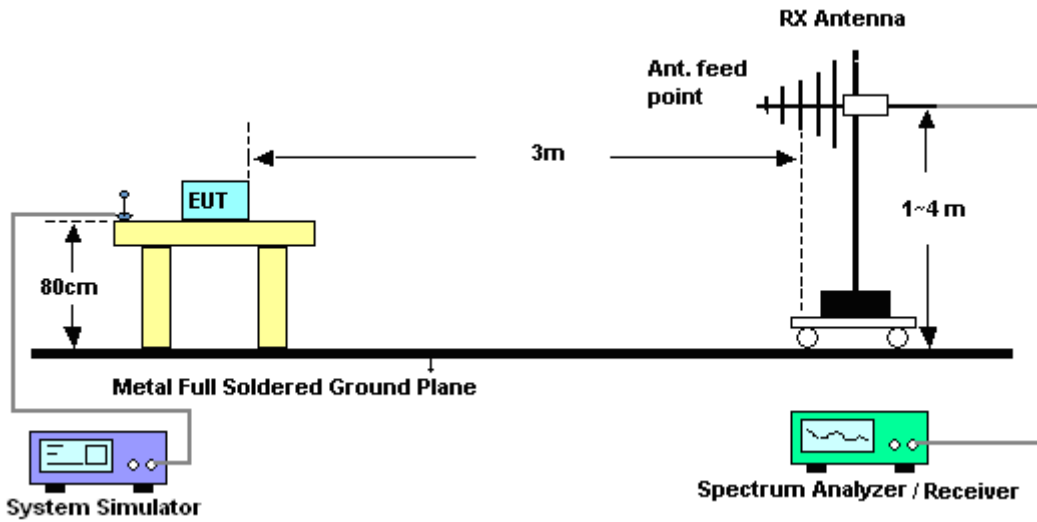

For radiated emissions above 1GHz

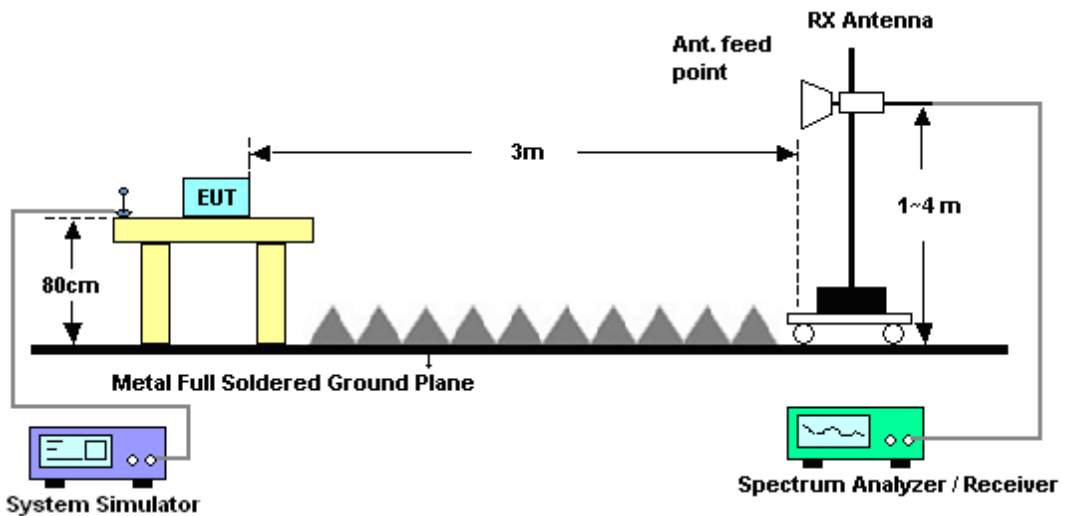



3.6.5 Test Result of Field Strength of Spurious Radiated

<Low Channel>

Band :	GSM850		Temperature :	23~24°C					
Test Mode :	GPRS class 8 Link (GMSK)		Relative Humidity :	46~48%					
Test Engineer :	Nick Yu, Ken Wu, and James Chiu		Polarization :	Horizontal					
Remark :	Spurious emissions within 30-1000MHz were found more than 20dB below limit line.								
Frequency (MHz)	ERP (dBm)	Limit (dBm)	Over Limit (dB)	SPA Reading (dBm)	S.G. Power (dBm)	TX Cable loss (dB)	TX Antenna Gain (dBi)	Polarization (H/V)	Result
1648	-43.88	-13	-30.88	-54.71	-45.64	0.98	4.89	H	Pass
2472	-44.09	-13	-31.09	-60	-45.97	1.28	5.32	H	Pass
3296	-44.36	-13	-31.36	-61.32	-47.77	1.54	7.10	H	Pass
4120	-51.34	-13	-38.34	-72.63	-55.98	1.83	8.62	H	Pass
4944	-41.58	-13	-28.58	-64.37	-46.71	2.30	9.59	H	Pass
5768	-50.85	-13	-37.85	-75.4	-55.73	2.78	9.81	H	Pass
6592	-51.71	-13	-38.71	-77.19	-57.15	2.72	10.31	H	Pass
7416	-52.11	-13	-39.11	-77.81	-59.14	2.46	11.63	H	Pass

Band :	GSM850		Temperature :	23~24°C					
Test Mode :	GPRS class 8 Link (GMSK)		Relative Humidity :	46~48%					
Test Engineer :	Nick Yu, Ken Wu, and James Chiu		Polarization :	Vertical					
Remark :	Spurious emissions within 30-1000MHz were found more than 20dB below limit line.								
Frequency (MHz)	ERP (dBm)	Limit (dBm)	Over Limit (dB)	SPA Reading (dBm)	S.G. Power (dBm)	TX Cable loss (dB)	TX Antenna Gain (dBi)	Polarization (H/V)	Result
1648	-42.15	-13	-29.15	-53.82	-43.91	0.98	4.89	V	Pass
2472	-34.84	-13	-21.84	-52.14	-36.72	1.28	5.32	V	Pass
3296	-37.14	-13	-24.14	-55.66	-40.55	1.54	7.10	V	Pass
4120	-41.70	-13	-28.70	-63.69	-46.34	1.83	8.62	V	Pass
4944	-39.02	-13	-26.02	-62.81	-44.15	2.30	9.59	V	Pass
5768	-49.03	-13	-36.03	-73.84	-53.91	2.78	9.81	V	Pass
6592	-48.97	-13	-35.97	-75.39	-54.41	2.72	10.31	V	Pass
7416	-48.12	-13	-35.12	-75.55	-55.15	2.46	11.63	V	Pass



<Middle Channel>

Band :	GSM850						Temperature :	23~24°C		
Test Mode :	GPRS class 8 Link (GMSK)						Relative Humidity :	46~48%		
Test Engineer :	Nick Yu, Ken Wu, and James Chiu						Polarization :	Horizontal		
Remark :	Spurious emissions within 30-1000MHz were found more than 20dB below limit line.									
Frequency (MHz)	ERP (dBm)	Limit (dBm)	Over Limit (dB)	SPA Reading (dBm)	S.G. Power (dBm)	TX Cable loss (dB)	TX Antenna Gain (dBi)	Polarization (H/V)	Result	
1672	-45.77	-13	-32.77	-56.75	-47.45	0.99	4.82	H	Pass	
2512	-43.55	-13	-30.55	-59.95	-45.52	1.29	5.41	H	Pass	
3344	-50.04	-13	-37.04	-67.26	-53.65	1.56	7.31	H	Pass	
4184	-53.56	-13	-40.56	-74.8	-58.18	1.87	8.64	H	Pass	
5016	-42.15	-13	-29.15	-64.93	-47.35	2.35	9.70	H	Pass	
5856	-51.71	-13	-38.71	-76.34	-56.57	2.83	9.84	H	Pass	
6688	-52.98	-13	-39.98	-78.82	-58.56	2.69	10.43	H	Pass	
7528	-51.06	-13	-38.06	-77.26	-58.31	2.42	11.82	H	Pass	

Band :	GSM850						Temperature :	23~24°C		
Test Mode :	GPRS class 8 Link (GMSK)						Relative Humidity :	46~48%		
Test Engineer :	Nick Yu, Ken Wu, and James Chiu						Polarization :	Vertical		
Remark :	Spurious emissions within 30-1000MHz were found more than 20dB below limit line.									
Frequency (MHz)	ERP (dBm)	Limit (dBm)	Over Limit (dB)	SPA Reading (dBm)	S.G. Power (dBm)	TX Cable loss (dB)	TX Antenna Gain (dBi)	Polarization (H/V)	Result	
1672	-42.74	-13	-29.74	-54.56	-44.42	0.99	4.82	V	Pass	
2512	-39.14	-13	-26.14	-56.97	-41.11	1.29	5.41	V	Pass	
3344	-39.16	-13	-26.16	-57.87	-42.77	1.56	7.31	V	Pass	
4184	-46.80	-13	-33.80	-68.78	-51.42	1.87	8.64	V	Pass	
5016	-42.24	-13	-29.24	-65.99	-47.44	2.35	9.70	V	Pass	
5856	-46.45	-13	-33.45	-71.52	-51.31	2.83	9.84	V	Pass	
6688	-48.78	-13	-35.78	-75.68	-54.36	2.69	10.43	V	Pass	
7528	-48.36	-13	-35.36	-76.44	-55.61	2.42	11.82	V	Pass	



<High Channel>

Band :	GSM850						Temperature :	23~24°C		
Test Mode :	GPRS class 8 Link (GMSK)						Relative Humidity :	46~48%		
Test Engineer :	Nick Yu, Ken Wu, and James Chiu						Polarization :	Horizontal		
Remark :	Spurious emissions within 30-1000MHz were found more than 20dB below limit line.									
Frequency (MHz)	ERP (dBm)	Limit (dBm)	Over Limit (dB)	SPA Reading (dBm)	S.G. Power (dBm)	TX Cable loss (dB)	TX Antenna Gain (dBi)	Polarization (H/V)	Result	
1696	-46.06	-13	-33.06	-57.12	-47.66	1.00	4.75	H	Pass	
2544	-51.53	-13	-38.53	-67.88	-53.51	1.30	5.44	H	Pass	
3392	-48.39	-13	-35.39	-65.83	-52.19	1.57	7.52	H	Pass	
4240	-51.50	-13	-38.50	-72.9	-56.1	1.90	8.65	H	Pass	
5096	-39.05	-13	-26.05	-61.79	-44.21	2.39	9.70	H	Pass	
5944	-50.78	-13	-37.78	-75.34	-55.63	2.88	9.88	H	Pass	
6792	-50.94	-13	-37.94	-76.97	-56.68	2.66	10.55	H	Pass	
7640	-47.26	-13	-34.26	-74.24	-54.61	2.38	11.88	H	Pass	

Band :	GSM850						Temperature :	23~24°C		
Test Mode :	GPRS class 8 Link (GMSK)						Relative Humidity :	46~48%		
Test Engineer :	Nick Yu, Ken Wu, and James Chiu						Polarization :	Vertical		
Remark :	Spurious emissions within 30-1000MHz were found more than 20dB below limit line.									
Frequency (MHz)	ERP (dBm)	Limit (dBm)	Over Limit (dB)	SPA Reading (dBm)	S.G. Power (dBm)	TX Cable loss (dB)	TX Antenna Gain (dBi)	Polarization (H/V)	Result	
1696	-46.72	-13	-33.72	-58.83	-48.32	1.00	4.75	V	Pass	
2544	-45.13	-13	-32.13	-63.19	-47.11	1.30	5.44	V	Pass	
3392	-35.45	-13	-22.45	-54.07	-39.25	1.57	7.52	V	Pass	
4240	-44.31	-13	-31.31	-66.39	-48.91	1.90	8.65	V	Pass	
5096	-40.39	-13	-27.39	-64.32	-45.55	2.39	9.70	V	Pass	
5944	-44.97	-13	-31.97	-70.22	-49.82	2.88	9.88	V	Pass	
6792	-46.70	-13	-33.70	-74.04	-52.44	2.66	10.55	V	Pass	
7640	-43.59	-13	-30.59	-72.24	-50.94	2.38	11.88	V	Pass	



<Low Channel>

Band :	GSM850						Temperature :	23~24°C	
Test Mode :	EDGE class 8 Link (8PSK)						Relative Humidity :	46~48%	
Test Engineer :	Nick Yu, Ken Wu, and James Chiu						Polarization :	Horizontal	
Remark :	Spurious emissions within 30-1000MHz were found more than 20dB below limit line.								
Frequency (MHz)	ERP (dBm)	Limit (dBm)	Over Limit (dB)	SPA Reading (dBm)	S.G. Power (dBm)	TX Cable loss (dB)	TX Antenna Gain (dBi)	Polarization (H/V)	Result
1648	-60.46	-13	-47.46	-71.1	-62.22	0.98	4.89	H	Pass
2472	-54.09	-13	-41.09	-69.96	-55.97	1.28	5.32	H	Pass
3296	-57.96	-13	-44.96	-74.62	-61.37	1.54	7.10	H	Pass
6592	-52.73	-13	-39.73	-78.31	-58.17	2.72	10.31	H	Pass

Band :	GSM850						Temperature :	23~24°C	
Test Mode :	EDGE class 8 Link (8PSK)						Relative Humidity :	46~48%	
Test Engineer :	Nick Yu, Ken Wu, and James Chiu						Polarization :	Vertical	
Remark :	Spurious emissions within 30-1000MHz were found more than 20dB below limit line.								
Frequency (MHz)	ERP (dBm)	Limit (dBm)	Over Limit (dB)	SPA Reading (dBm)	S.G. Power (dBm)	TX Cable loss (dB)	TX Antenna Gain (dBi)	Polarization (H/V)	Result
1648	-57.61	-13	-44.61	-69.15	-59.37	0.98	4.89	V	Pass
2472	-50.74	-13	-37.74	-68.17	-52.62	1.28	5.32	V	Pass
3296	-51.98	-13	-38.98	-70.5	-55.39	1.54	7.10	V	Pass
6592	-49.22	-13	-36.22	-75.64	-54.66	2.72	10.31	V	Pass



<Middle Channel>

Band :	GSM850						Temperature :	23~24°C		
Test Mode :	EDGE class 8 Link (8PSK)						Relative Humidity :	46~48%		
Test Engineer :	Nick Yu, Ken Wu, and James Chiu						Polarization :	Horizontal		
Remark :	Spurious emissions within 30-1000MHz were found more than 20dB below limit line.									
Frequency (MHz)	ERP (dBm)	Limit (dBm)	Over Limit (dB)	SPA Reading (dBm)	S.G. Power (dBm)	TX Cable loss (dB)	TX Antenna Gain (dBi)	Polarization (H/V)	Result	
1672	-59.53	-13	-46.53	-70.42	-61.21	0.99	4.82	H	Pass	
2542	-56.41	-13	-43.41	-72.44	-58.39	1.30	5.43	H	Pass	
3344	-56.41	-13	-43.41	-73.63	-60.02	1.56	7.31	H	Pass	
6688	-52.13	-13	-39.13	-77.97	-57.71	2.69	10.43	H	Pass	

Band :	GSM850						Temperature :	23~24°C		
Test Mode :	EDGE class 8 Link (8PSK)						Relative Humidity :	46~48%		
Test Engineer :	Nick Yu, Ken Wu, and James Chiu						Polarization :	Vertical		
Remark :	Spurious emissions within 30-1000MHz were found more than 20dB below limit line.									
Frequency (MHz)	ERP (dBm)	Limit (dBm)	Over Limit (dB)	SPA Reading (dBm)	S.G. Power (dBm)	TX Cable loss (dB)	TX Antenna Gain (dBi)	Polarization (H/V)	Result	
1672	-57.54	-13	-44.54	-69.26	-59.22	0.99	4.82	V	Pass	
2542	-50.97	-13	-37.97	-68.71	-52.95	1.30	5.43	V	Pass	
3344	-48.57	-13	-35.57	-67.28	-52.18	1.56	7.31	V	Pass	
6688	-49.03	-13	-36.03	-75.92	-54.61	2.69	10.43	V	Pass	



<High Channel>

Band :	GSM850						Temperature :	23~24°C		
Test Mode :	EDGE class 8 Link (8PSK)						Relative Humidity :	46~48%		
Test Engineer :	Nick Yu, Ken Wu, and James Chiu						Polarization :	Horizontal		
Remark :	Spurious emissions within 30-1000MHz were found more than 20dB below limit line.									
Frequency (MHz)	ERP (dBm)	Limit (dBm)	Over Limit (dB)	SPA Reading (dBm)	S.G. Power (dBm)	TX Cable loss (dB)	TX Antenna Gain (dBi)	Polarization (H/V)	Result	
1696	-63.06	-13	-50.06	-74.12	-64.66	1.00	4.75	H	Pass	
2544	-57.89	-13	-44.89	-74.17	-59.87	1.30	5.44	H	Pass	
3392	-58.96	-13	-45.96	-76.5	-62.76	1.57	7.52	H	Pass	
6792	-51.97	-13	-38.97	-77.76	-57.71	2.66	10.55	H	Pass	

Band :	GSM850						Temperature :	23~24°C		
Test Mode :	EDGE class 8 Link (8PSK)						Relative Humidity :	46~48%		
Test Engineer :	Nick Yu, Ken Wu, and James Chiu						Polarization :	Vertical		
Remark :	Spurious emissions within 30-1000MHz were found more than 20dB below limit line.									
Frequency (MHz)	ERP (dBm)	Limit (dBm)	Over Limit (dB)	SPA Reading (dBm)	S.G. Power (dBm)	TX Cable loss (dB)	TX Antenna Gain (dBi)	Polarization (H/V)	Result	
1696	-63.01	-13	-50.01	-75.12	-64.61	1.00	4.75	V	Pass	
2544	-52.74	-13	-39.74	-70.16	-56.87	1.30	5.44	V	Pass	
3392	-51.27	-13	-38.27	-69.65	-57.22	1.57	7.52	V	Pass	
6792	-49.22	-13	-36.22	-76.48	-57.11	2.66	10.55	V	Pass	



<Low Channel>

Band :	GSM1900		Temperature :	23~24°C					
Test Mode :	GPRS class 8 Link (GMSK)		Relative Humidity :	46~48%					
Test Engineer :	Nick Yu, Ken Wu, and James Chiu		Polarization :	Horizontal					
Remark :	Spurious emissions within 30-1000MHz were found more than 20dB below limit line.								
Frequency (MHz)	EIRP (dBm)	Limit (dBm)	Over Limit (dB)	SPA Reading (dBm)	S.G. Power (dBm)	TX Cable loss (dB)	TX Antenna Gain (dBi)	Polarization (H/V)	Result
3700	-29.73	-13	-16.73	-49.21	-36.3	1.67	8.24	H	Pass
5548	-25.13	-13	-12.13	-49.9	-32.2	2.65	9.72	H	Pass
7403	-28.25	-13	-15.25	-55.12	-37.4	2.46	11.61	H	Pass
9251	-37.44	-13	-24.44	-64.93	-47.5	2.54	12.60	H	Pass
11102	-42.33	-13	-29.33	-73.57	-52.1	2.69	12.46	H	Pass

Band :	GSM1900		Temperature :	23~24°C					
Test Mode :	GPRS class 8 Link (GMSK)		Relative Humidity :	46~48%					
Test Engineer :	Nick Yu, Ken Wu, and James Chiu		Polarization :	Vertical					
Remark :	Spurious emissions within 30-1000MHz were found more than 20dB below limit line.								
Frequency (MHz)	EIRP (dBm)	Limit (dBm)	Over Limit (dB)	SPA Reading (dBm)	S.G. Power (dBm)	TX Cable loss (dB)	TX Antenna Gain (dBi)	Polarization (H/V)	Result
3700	-20.53	-13	-7.53	-40.67	-27.1	1.67	8.24	V	Pass
5548	-22.03	-13	-9.03	-48.25	-29.1	2.65	9.72	V	Pass
7403	-25.45	-13	-12.45	-53.84	-34.6	2.46	11.61	V	Pass
9251	-30.64	-13	-17.64	-60.27	-40.7	2.54	12.60	V	Pass
11102	-34.83	-13	-21.83	-68.69	-44.6	2.69	12.46	V	Pass
12954	-41.07	-13	-28.07	-77.14	-51.1	2.92	12.94	V	Pass



<Middle Channel>

Band :	GSM1900						Temperature :	23~24°C		
Test Mode :	GPRS class 8 Link (GMSK)						Relative Humidity :	46~48%		
Test Engineer :	Nick Yu, Ken Wu, and James Chiu						Polarization :	Horizontal		
Remark :	Spurious emissions within 30-1000MHz were found more than 20dB below limit line.									
Frequency (MHz)	EIRP (dBm)	Limit (dBm)	Over Limit (dB)	SPA Reading (dBm)	S.G. Power (dBm)	TX Cable loss (dB)	TX Antenna Gain (dBi)	Polarization (H/V)	Result	
3756	-30.88	-13	-17.88	-50.35	-37.5	1.68	8.31	H	Pass	
5639	-27.55	-13	-14.55	-52.65	-34.6	2.71	9.76	H	Pass	
7522	-26.21	-13	-13.21	-53.26	-35.6	2.42	11.81	H	Pass	
9398	-35.83	-13	-22.83	-63.42	-45.8	2.57	12.54	H	Pass	
11282	-44.40	-13	-31.40	-76.68	-54.1	2.68	12.39	H	Pass	
13163	-45.24	-13	-32.24	-79.03	-55.5	2.97	13.23	H	Pass	

Band :	GSM1900						Temperature :	23~24°C		
Test Mode :	GPRS class 8 Link (GMSK)						Relative Humidity :	46~48%		
Test Engineer :	Nick Yu, Ken Wu, and James Chiu						Polarization :	Vertical		
Remark :	Spurious emissions within 30-1000MHz were found more than 20dB below limit line.									
Frequency (MHz)	EIRP (dBm)	Limit (dBm)	Over Limit (dB)	SPA Reading (dBm)	S.G. Power (dBm)	TX Cable loss (dB)	TX Antenna Gain (dBi)	Polarization (H/V)	Result	
3756	-21.58	-13	-8.58	-41.7	-28.2	1.68	8.31	V	Pass	
5639	-25.75	-13	-12.75	-51.62	-32.8	2.71	9.76	V	Pass	
7522	-20.91	-13	-7.91	-49.72	-30.3	2.42	11.81	V	Pass	
9398	-33.13	-13	-20.13	-63.31	-43.1	2.57	12.54	V	Pass	
11282	-35.70	-13	-22.70	-70.04	-45.4	2.68	12.39	V	Pass	
13163	-40.32	-13	-27.32	-76.12	-50.58	2.97	13.23	V	Pass	



<High Channel>

Band :	GSM1900						Temperature :	23~24°C		
Test Mode :	GPRS class 8 Link (GMSK)						Relative Humidity :	46~48%		
Test Engineer :	Nick Yu, Ken Wu, and James Chiu						Polarization :	Horizontal		
Remark :	Spurious emissions within 30-1000MHz were found more than 20dB below limit line.									
Frequency (MHz)	EIRP (dBm)	Limit (dBm)	Over Limit (dB)	SPA Reading (dBm)	S.G. Power (dBm)	TX Cable loss (dB)	TX Antenna Gain (dBi)	Polarization (H/V)	Result	
3819	-32.62	-13	-19.62	-53.74	-39.3	1.70	8.38	H	Pass	
5730	-28.47	-13	-15.47	-53.55	-35.5	2.76	9.79	H	Pass	
7641	-23.30	-13	-10.30	-51.06	-32.8	2.38	11.88	H	Pass	
9552	-34.23	-13	-21.23	-62.12	-44.1	2.60	12.47	H	Pass	
11453	-45.76	-13	-32.76	-78.27	-55.4	2.68	12.32	H	Pass	
13372	-45.00	-13	-32.00	-78.28	-55.5	3.02	13.52	H	Pass	

Band :	GSM1900						Temperature :	23~24°C		
Test Mode :	GPRS class 8 Link (GMSK)						Relative Humidity :	46~48%		
Test Engineer :	Nick Yu, Ken Wu, and James Chiu						Polarization :	Vertical		
Remark :	Spurious emissions within 30-1000MHz were found more than 20dB below limit line.									
Frequency (MHz)	EIRP (dBm)	Limit (dBm)	Over Limit (dB)	SPA Reading (dBm)	S.G. Power (dBm)	TX Cable loss (dB)	TX Antenna Gain (dBi)	Polarization (H/V)	Result	
3819	-20.92	-13	-7.92	-42.24	-27.6	1.70	8.38	V	Pass	
5730	-21.77	-13	-8.77	-47.67	-28.8	2.76	9.79	V	Pass	
7641	-19.40	-13	-6.40	-48.62	-28.9	2.38	11.88	V	Pass	
9552	-33.63	-13	-20.63	-63.89	-43.5	2.60	12.47	V	Pass	
11453	-35.86	-13	-22.86	-70.51	-45.5	2.68	12.32	V	Pass	
13372	-42.10	-13	-29.10	-77.6	-52.6	3.02	13.52	V	Pass	



<Low Channel>

Band :	GSM1900		Temperature :	23~24°C					
Test Mode :	EDGE class 8 Link (8PSK)		Relative Humidity :	46~48%					
Test Engineer :	Nick Yu, Ken Wu, and James Chiu		Polarization :	Horizontal					
Remark :	Spurious emissions within 30-1000MHz were found more than 20dB below limit line.								
Frequency (MHz)	EIRP (dBm)	Limit (dBm)	Over Limit (dB)	SPA Reading (dBm)	S.G. Power (dBm)	TX Cable loss (dB)	TX Antenna Gain (dBi)	Polarization (H/V)	Result
3700	-57.03	-13	-44.03	-76.29	-63.6	1.67	8.24	H	Pass
5548	-54.33	-13	-41.33	-78.98	-61.4	2.65	9.72	H	Pass
7403	-48.05	-13	-35.05	-75.02	-57.2	2.46	11.61	H	Pass

Band :	GSM1900		Temperature :	23~24°C					
Test Mode :	EDGE class 8 Link (8PSK)		Relative Humidity :	46~48%					
Test Engineer :	Nick Yu, Ken Wu, and James Chiu		Polarization :	Vertical					
Remark :	Spurious emissions within 30-1000MHz were found more than 20dB below limit line.								
Frequency (MHz)	EIRP (dBm)	Limit (dBm)	Over Limit (dB)	SPA Reading (dBm)	S.G. Power (dBm)	TX Cable loss (dB)	TX Antenna Gain (dBi)	Polarization (H/V)	Result
3700	-47.23	-13	-34.23	-67.61	-53.8	1.67	8.24	V	Pass
5548	-51.53	-13	-38.53	-77.43	-58.6	2.65	9.72	V	Pass
7403	-44.45	-13	-31.45	-72.91	-53.6	2.46	11.61	V	Pass



<Middle Channel>

Band :	GSM1900		Temperature :	23~24°C					
Test Mode :	EDGE class 8 Link (8PSK)		Relative Humidity :	46~48%					
Test Engineer :	Nick Yu, Ken Wu, and James Chiu		Polarization :	Horizontal					
Remark :	Spurious emissions within 30-1000MHz were found more than 20dB below limit line.								
Frequency (MHz)	EIRP (dBm)	Limit (dBm)	Over Limit (dB)	SPA Reading (dBm)	S.G. Power (dBm)	TX Cable loss (dB)	TX Antenna Gain (dBi)	Polarization (H/V)	Result
3756	-54.98	-13	-41.98	-74.5	-61.6	1.68	8.31	H	Pass
5639	-48.25	-13	-35.25	-73.14	-55.3	2.71	9.76	H	Pass
7522	-46.81	-13	-33.81	-74.4	-56.2	2.42	11.81	H	Pass

Band :	GSM1900		Temperature :	23~24°C					
Test Mode :	EDGE class 8 Link (8PSK)		Relative Humidity :	46~48%					
Test Engineer :	Nick Yu, Ken Wu, and James Chiu		Polarization :	Vertical					
Remark :	Spurious emissions within 30-1000MHz were found more than 20dB below limit line.								
Frequency (MHz)	EIRP (dBm)	Limit (dBm)	Over Limit (dB)	SPA Reading (dBm)	S.G. Power (dBm)	TX Cable loss (dB)	TX Antenna Gain (dBi)	Polarization (H/V)	Result
3756	-46.48	-13	-33.48	-67.17	-53.1	1.68	8.31	V	Pass
5639	-45.55	-13	-32.55	-71.77	-52.6	2.71	9.76	V	Pass
7522	-40.71	-13	-27.71	-69.88	-50.1	2.42	11.81	V	Pass



<High Channel>

Band :	GSM1900						Temperature :	23~24°C		
Test Mode :	EDGE class 8 Link (8PSK)						Relative Humidity :	46~48%		
Test Engineer :	Nick Yu, Ken Wu, and James Chiu						Polarization :	Horizontal		
Remark :	Spurious emissions within 30-1000MHz were found more than 20dB below limit line.									
Frequency (MHz)	EIRP (dBm)	Limit (dBm)	Over Limit (dB)	SPA Reading (dBm)	S.G. Power (dBm)	TX Cable loss (dB)	TX Antenna Gain (dBi)	Polarization (H/V)	Result	
3819	-54.42	-13	-41.42	-75.15	-61.1	1.70	8.38	H	Pass	
5730	-51.87	-13	-38.87	-77.03	-58.9	2.76	9.79	H	Pass	
7641	-44.00	-13	-31.00	-71.79	-53.5	2.38	11.88	H	Pass	

Band :	GSM1900						Temperature :	23~24°C		
Test Mode :	EDGE class 8 Link (8PSK)						Relative Humidity :	46~48%		
Test Engineer :	Nick Yu, Ken Wu, and James Chiu						Polarization :	Vertical		
Remark :	Spurious emissions within 30-1000MHz were found more than 20dB below limit line.									
Frequency (MHz)	EIRP (dBm)	Limit (dBm)	Over Limit (dB)	SPA Reading (dBm)	S.G. Power (dBm)	TX Cable loss (dB)	TX Antenna Gain (dBi)	Polarization (H/V)	Result	
3819	-45.52	-13	-32.52	-66.87	-52.2	1.70	8.38	V	Pass	
5730	-48.47	-13	-35.47	-73.99	-55.5	2.76	9.79	V	Pass	
7641	-41.60	-13	-28.60	-71.03	-51.1	2.38	11.88	V	Pass	



<Low Channel>

Band :	WCDMA Band V						Temperature :	23~24°C		
Test Mode :	RMC 12.2Kbps Link (QPSK)						Relative Humidity :	46~48%		
Test Engineer :	Nick Yu, Ken Wu, and James Chiu						Polarization :	Horizontal		
Remark :	Spurious emissions within 30-1000MHz were found more than 20dB below limit line.									
Frequency (MHz)	ERP (dBm)	Limit (dBm)	Over Limit (dB)	SPA Reading (dBm)	S.G. Power (dBm)	TX Cable loss (dB)	TX Antenna Gain (dBi)	Polarization (H/V)	Result	
1656	-42.61	-13	-29.61	-53.49	-44.34	0.98	4.86	H	Pass	
2480	-53.93	-13	-40.93	-69.92	-55.84	1.28	5.34	H	Pass	
3304	-52.27	-13	-39.27	-69.25	-55.71	1.54	7.14	H	Pass	
4136	-45.49	-13	-32.49	-66.63	-50.13	1.84	8.63	H	Pass	
4960	-40.95	-13	-27.95	-63.73	-46.11	2.31	9.62	H	Pass	

Band :	WCDMA Band V						Temperature :	23~24°C		
Test Mode :	RMC 12.2Kbps Link (QPSK)						Relative Humidity :	46~48%		
Test Engineer :	Nick Yu, Ken Wu, and James Chiu						Polarization :	Vertical		
Remark :	Spurious emissions within 30-1000MHz were found more than 20dB below limit line.									
Frequency (MHz)	ERP (dBm)	Limit (dBm)	Over Limit (dB)	SPA Reading (dBm)	S.G. Power (dBm)	TX Cable loss (dB)	TX Antenna Gain (dBi)	Polarization (H/V)	Result	
1648	-39.88	-13	-26.88	-51.51	-41.64	0.98	4.89	V	Pass	
2472	-51.04	-13	-38.04	-68.16	-52.92	1.28	5.32	V	Pass	
3312	-49.16	-13	-36.16	-67.74	-52.64	1.55	7.17	V	Pass	
4128	-44.57	-13	-31.57	-66.47	-49.21	1.83	8.63	V	Pass	
4952	-43.25	-13	-30.25	-67	-48.39	2.31	9.60	V	Pass	



<Middle Channel>

Band :	WCDMA Band V	Temperature :	23~24°C						
Test Mode :	RMC 12.2Kbps Link (QPSK)	Relative Humidity :	46~48%						
Test Engineer :	Nick Yu, Ken Wu, and James Chiu	Polarization :	Horizontal						
Remark :	Spurious emissions within 30-1000MHz were found more than 20dB below limit line.								
Frequency (MHz)	ERP (dBm)	Limit (dBm)	Over Limit (dB)	SPA Reading (dBm)	S.G. Power (dBm)	TX Cable loss (dB)	TX Antenna Gain (dBi)	Polarization (H/V)	Result
1672	-45.17	-13	-32.17	-55.88	-46.85	0.99	4.82	H	Pass
2512	-54.81	-13	-41.81	-70.91	-56.78	1.29	5.41	H	Pass
3352	-52.78	-13	-39.78	-69.89	-56.42	1.56	7.35	H	Pass
4184	-46.23	-13	-33.23	-67.3	-50.85	1.87	8.64	H	Pass
5016	-43.22	-13	-30.22	-65.98	-48.42	2.35	9.70	H	Pass
7520	-52.04	-13	-39.04	-78.41	-59.28	2.42	11.81	H	Pass

Band :	WCDMA Band V	Temperature :	23~24°C						
Test Mode :	RMC 12.2Kbps Link (QPSK)	Relative Humidity :	46~48%						
Test Engineer :	Nick Yu, Ken Wu, and James Chiu	Polarization :	Vertical						
Remark :	Spurious emissions within 30-1000MHz were found more than 20dB below limit line.								
Frequency (MHz)	ERP (dBm)	Limit (dBm)	Over Limit (dB)	SPA Reading (dBm)	S.G. Power (dBm)	TX Cable loss (dB)	TX Antenna Gain (dBi)	Polarization (H/V)	Result
1672	-41.69	-13	-28.69	-53.41	-43.37	0.99	4.82	V	Pass
2512	-51.94	-13	-38.94	-69.77	-53.91	1.29	5.41	V	Pass
3352	-48.21	-13	-35.21	-66.68	-51.85	1.56	7.35	V	Pass
4184	-45.49	-13	-32.49	-67.46	-50.11	1.87	8.64	V	Pass
5016	-44.41	-13	-31.41	-68.16	-49.61	2.35	9.70	V	Pass
7520	-49.03	-13	-36.03	-77.24	-56.27	2.42	11.81	V	Pass



<High Channel>

Band :	WCDMA Band V						Temperature :	23~24°C	
Test Mode :	RMC 12.2Kbps Link (QPSK)						Relative Humidity :	46~48%	
Test Engineer :	Nick Yu, Ken Wu, and James Chiu						Polarization :	Horizontal	
Remark :	Spurious emissions within 30-1000MHz were found more than 20dB below limit line.								
Frequency (MHz)	ERP (dBm)	Limit (dBm)	Over Limit (dB)	SPA Reading (dBm)	S.G. Power (dBm)	TX Cable loss (dB)	TX Antenna Gain (dBi)	Polarization (H/V)	Result
1688	-44.24	-13	-31.24	-55.32	-45.87	1.00	4.77	H	Pass
2544	-55.24	-13	-42.24	-71.45	-57.22	1.30	5.44	H	Pass
3392	-50.92	-13	-37.92	-68.01	-54.72	1.57	7.52	H	Pass
4224	-45.19	-13	-32.19	-66.65	-49.79	1.89	8.64	H	Pass
5072	-42.56	-13	-29.56	-65.31	-47.73	2.38	9.70	H	Pass

Band :	WCDMA Band V						Temperature :	23~24°C	
Test Mode :	RMC 12.2Kbps Link (QPSK)						Relative Humidity :	46~48%	
Test Engineer :	Nick Yu, Ken Wu, and James Chiu						Polarization :	Vertical	
Remark :	Spurious emissions within 30-1000MHz were found more than 20dB below limit line.								
Frequency (MHz)	ERP (dBm)	Limit (dBm)	Over Limit (dB)	SPA Reading (dBm)	S.G. Power (dBm)	TX Cable loss (dB)	TX Antenna Gain (dBi)	Polarization (H/V)	Result
1688	-43.24	-13	-30.24	-55.03	-44.87	1.00	4.77	V	Pass
2536	-53.66	-13	-40.66	-71.2	-55.64	1.30	5.43	V	Pass
3384	-47.60	-13	-34.60	-66.05	-51.37	1.57	7.49	V	Pass
4224	-45.13	-13	-32.13	-66.95	-49.73	1.89	8.64	V	Pass
5080	-44.49	-13	-31.49	-68.26	-49.66	2.38	9.70	V	Pass



<Low Channel>

Band :	WCDMA Band IV						Temperature :	23~24°C		
Test Mode :	RMC 12.2Kbps Link (QPSK)						Relative Humidity :	46~48%		
Test Engineer :	Nick Yu, Ken Wu, and James Chiu						Polarization :	Horizontal		
Remark :	Spurious emissions within 30-1000MHz were found more than 20dB below limit line.									
Frequency (MHz)	EIRP (dBm)	Limit (dBm)	Over Limit (dB)	SPA Reading (dBm)	S.G. Power (dBm)	TX Cable loss (dB)	TX Antenna Gain (dBi)	Polarization (H/V)	Result	
3424	-46.67	-13	-33.67	-63.53	-52.76	1.58	7.67	H	Pass	
5135	-49.34	-13	-36.34	-72.21	-56.63	2.41	9.70	H	Pass	
6850	-45.00	-13	-32.00	-70.95	-52.98	2.64	10.62	H	Pass	
8565	-40.68	-13	-27.68	-66.62	-50.82	2.39	12.53	H	Pass	
10272	-48.36	-13	-35.36	-76.85	-57.97	2.69	12.31	H	Pass	

Band :	WCDMA Band IV						Temperature :	23~24°C		
Test Mode :	RMC 12.2Kbps Link (QPSK)						Relative Humidity :	46~48%		
Test Engineer :	Nick Yu, Ken Wu, and James Chiu						Polarization :	Vertical		
Remark :	Spurious emissions within 30-1000MHz were found more than 20dB below limit line.									
Frequency (MHz)	EIRP (dBm)	Limit (dBm)	Over Limit (dB)	SPA Reading (dBm)	S.G. Power (dBm)	TX Cable loss (dB)	TX Antenna Gain (dBi)	Polarization (H/V)	Result	
3427	-38.32	-13	-25.32	-56.49	-44.42	1.58	7.68	V	Pass	
5135	-49.17	-13	-36.17	-73.09	-56.46	2.41	9.70	V	Pass	
6850	-39.73	-13	-26.73	-67.31	-47.71	2.64	10.62	V	Pass	
8565	-34.97	-13	-21.97	-62.84	-45.11	2.39	12.53	V	Pass	



<Middle Channel>

Band :	WCDMA Band IV						Temperature :	23~24°C	
Test Mode :	RMC 12.2Kbps Link (QPSK)						Relative Humidity :	46~48%	
Test Engineer :	Nick Yu, Ken Wu, and James Chiu						Polarization :	Horizontal	
Remark :	Spurious emissions within 30-1000MHz were found more than 20dB below limit line.								
Frequency (MHz)	EIRP (dBm)	Limit (dBm)	Over Limit (dB)	SPA Reading (dBm)	S.G. Power (dBm)	TX Cable loss (dB)	TX Antenna Gain (dBi)	Polarization (H/V)	Result
3465	-45.87	-13	-32.87	-62.92	-52.12	1.59	7.85	H	Pass
5198	-45.57	-13	-32.57	-68.4	-52.82	2.45	9.70	H	Pass
6927	-40.52	-13	-27.52	-66.33	-48.62	2.61	10.71	H	Pass
8663	-40.47	-13	-27.47	-66.45	-50.62	2.41	12.57	H	Pass
10392	-47.65	-13	-34.65	-76.67	-57.31	2.69	12.36	H	Pass

Band :	WCDMA Band IV						Temperature :	23~24°C	
Test Mode :	RMC 12.2Kbps Link (QPSK)						Relative Humidity :	46~48%	
Test Engineer :	Nick Yu, Ken Wu, and James Chiu						Polarization :	Vertical	
Remark :	Spurious emissions within 30-1000MHz were found more than 20dB below limit line.								
Frequency (MHz)	EIRP (dBm)	Limit (dBm)	Over Limit (dB)	SPA Reading (dBm)	S.G. Power (dBm)	TX Cable loss (dB)	TX Antenna Gain (dBi)	Polarization (H/V)	Result
3462	-38.69	-13	-25.69	-57.04	-44.93	1.59	7.83	V	Pass
5198	-46.20	-13	-33.20	-70.13	-53.45	2.45	9.70	V	Pass
6927	-37.48	-13	-24.48	-64.13	-45.58	2.61	10.71	V	Pass
8663	-33.37	-13	-20.37	-61.51	-43.52	2.41	12.57	V	Pass
10392	-45.52	-13	-32.52	-77.12	-55.18	2.69	12.36	V	Pass



<High Channel>

Band :	WCDMA Band IV						Temperature :	23~24°C	
Test Mode :	RMC 12.2Kbps Link (QPSK)						Relative Humidity :	46~48%	
Test Engineer :	Nick Yu, Ken Wu, and James Chiu						Polarization :	Horizontal	
Remark :	Spurious emissions within 30-1000MHz were found more than 20dB below limit line.								
Frequency (MHz)	EIRP (dBm)	Limit (dBm)	Over Limit (dB)	SPA Reading (dBm)	S.G. Power (dBm)	TX Cable loss (dB)	TX Antenna Gain (dBi)	Polarization (H/V)	Result
3504	-45.93	-13	-32.93	-63.15	-52.33	1.61	8.00	H	Pass
5254	-46.60	-13	-33.60	-70.19	-53.82	2.48	9.70	H	Pass
7011	-42.63	-13	-29.63	-68.32	-50.87	2.59	10.82	H	Pass
8761	-37.80	-13	-24.80	-63.76	-47.97	2.43	12.60	H	Pass
10512	-48.17	-13	-35.17	-77.59	-57.88	2.69	12.40	H	Pass

Band :	WCDMA Band IV						Temperature :	23~24°C	
Test Mode :	RMC 12.2Kbps Link (QPSK)						Relative Humidity :	46~48%	
Test Engineer :	Nick Yu, Ken Wu, and James Chiu						Polarization :	Vertical	
Remark :	Spurious emissions within 30-1000MHz were found more than 20dB below limit line.								
Frequency (MHz)	EIRP (dBm)	Limit (dBm)	Over Limit (dB)	SPA Reading (dBm)	S.G. Power (dBm)	TX Cable loss (dB)	TX Antenna Gain (dBi)	Polarization (H/V)	Result
3504	-38.36	-13	-25.36	-56.92	-44.76	1.61	8.00	V	Pass
5254	-48.57	-13	-35.57	-72.04	-55.79	2.48	9.70	V	Pass
7011	-36.92	-13	-23.92	-63.55	-45.16	2.59	10.82	V	Pass
8761	-33.07	-13	-20.07	-61.41	-43.24	2.43	12.60	V	Pass
10512	-45.15	-13	-32.15	-77.15	-54.86	2.69	12.40	V	Pass



<Low Channel>

Band :	WCDMA Band II						Temperature :	23~24°C		
Test Mode :	RMC 12.2Kbps Link (QPSK)						Relative Humidity :	46~48%		
Test Engineer :	Nick Yu, Ken Wu, and James Chiu						Polarization :	Horizontal		
Remark :	Spurious emissions within 30-1000MHz were found more than 20dB below limit line.									
Frequency (MHz)	EIRP (dBm)	Limit (dBm)	Over Limit (dB)	SPA Reading (dBm)	S.G. Power (dBm)	TX Cable loss (dB)	TX Antenna Gain (dBi)	Polarization (H/V)	Result	
3700	-43.03	-13	-30.03	-62.2	-49.6	1.67	8.24	H	Pass	
5555	-46.53	-13	-33.53	-71.39	-53.6	2.66	9.72	H	Pass	
7417	-38.92	-13	-25.92	-65.61	-48.1	2.46	11.63	H	Pass	
9258	-43.84	-13	-30.84	-70.98	-53.9	2.54	12.60	H	Pass	

Band :	WCDMA Band II						Temperature :	23~24°C		
Test Mode :	RMC 12.2Kbps Link (QPSK)						Relative Humidity :	46~48%		
Test Engineer :	Nick Yu, Ken Wu, and James Chiu						Polarization :	Vertical		
Remark :	Spurious emissions within 30-1000MHz were found more than 20dB below limit line.									
Frequency (MHz)	EIRP (dBm)	Limit (dBm)	Over Limit (dB)	SPA Reading (dBm)	S.G. Power (dBm)	TX Cable loss (dB)	TX Antenna Gain (dBi)	Polarization (H/V)	Result	
3700	-38.93	-13	-25.93	-58.94	-45.5	1.67	8.24	V	Pass	
5562	-47.14	-13	-34.14	-73.39	-54.2	2.66	9.72	V	Pass	
7403	-36.75	-13	-23.75	-64.88	-45.9	2.46	11.61	V	Pass	
9258	-40.64	-13	-27.64	-70.53	-50.7	2.54	12.60	V	Pass	



<Middle Channel>

Band :	WCDMA Band II	Temperature :	23~24°C						
Test Mode :	RMC 12.2Kbps Link (QPSK)	Relative Humidity :	46~48%						
Test Engineer :	Nick Yu, Ken Wu, and James Chiu	Polarization :	Horizontal						
Remark :	Spurious emissions within 30-1000MHz were found more than 20dB below limit line.								
Frequency (MHz)	EIRP (dBm)	Limit (dBm)	Over Limit (dB)	SPA Reading (dBm)	S.G. Power (dBm)	TX Cable loss (dB)	TX Antenna Gain (dBi)	Polarization (H/V)	Result
3756	-47.18	-13	-34.18	-66.69	-53.8	1.68	8.31	H	Pass
5646	-44.25	-13	-31.25	-68.99	-51.3	2.71	9.76	H	Pass
7522	-36.11	-13	-23.11	-63.12	-45.5	2.42	11.81	H	Pass
9398	-44.23	-13	-31.23	-71.93	-54.2	2.57	12.54	H	Pass

Band :	WCDMA Band II	Temperature :	23~24°C						
Test Mode :	RMC 12.2Kbps Link (QPSK)	Relative Humidity :	46~48%						
Test Engineer :	Nick Yu, Ken Wu, and James Chiu	Polarization :	Vertical						
Remark :	Spurious emissions within 30-1000MHz were found more than 20dB below limit line.								
Frequency (MHz)	EIRP (dBm)	Limit (dBm)	Over Limit (dB)	SPA Reading (dBm)	S.G. Power (dBm)	TX Cable loss (dB)	TX Antenna Gain (dBi)	Polarization (H/V)	Result
3756	-41.88	-13	-28.88	-62.33	-48.5	1.68	8.31	V	Pass
5639	-44.15	-13	-31.15	-69.96	-51.2	2.71	9.76	V	Pass
7522	-32.61	-13	-19.61	-61.4	-42	2.42	11.81	V	Pass
9398	-40.93	-13	-27.93	-71.19	-50.9	2.57	12.54	V	Pass



<High Channel>

Band :	WCDMA Band II						Temperature :	23~24°C		
Test Mode :	RMC 12.2Kbps Link (QPSK)						Relative Humidity :	46~48%		
Test Engineer :	Nick Yu, Ken Wu, and James Chiu						Polarization :	Horizontal		
Remark :	Spurious emissions within 30-1000MHz were found more than 20dB below limit line.									
Frequency (MHz)	EIRP (dBm)	Limit (dBm)	Over Limit (dB)	SPA Reading (dBm)	S.G. Power (dBm)	TX Cable loss (dB)	TX Antenna Gain (dBi)	Polarization (H/V)	Result	
3819	-28.12	-13	-15.12	-49.18	-34.8	1.70	8.38	H	Pass	
5716	-42.76	-13	-29.76	-67.78	-49.8	2.75	9.79	H	Pass	
7634	-34.61	-13	-21.61	-62.18	-44.1	2.39	11.88	H	Pass	
9531	-47.51	-13	-34.51	-75.23	-57.4	2.60	12.48	H	Pass	

Band :	WCDMA Band II						Temperature :	23~24°C		
Test Mode :	RMC 12.2Kbps Link (QPSK)						Relative Humidity :	46~48%		
Test Engineer :	Nick Yu, Ken Wu, and James Chiu						Polarization :	Vertical		
Remark :	Spurious emissions within 30-1000MHz were found more than 20dB below limit line.									
Frequency (MHz)	EIRP (dBm)	Limit (dBm)	Over Limit (dB)	SPA Reading (dBm)	S.G. Power (dBm)	TX Cable loss (dB)	TX Antenna Gain (dBi)	Polarization (H/V)	Result	
3819	-25.42	-13	-12.42	-46.61	-32.1	1.70	8.38	V	Pass	
5723	-43.86	-13	-30.86	-69.66	-50.9	2.75	9.79	V	Pass	
7627	-31.61	-13	-18.61	-60.69	-41.1	2.39	11.88	V	Pass	
9531	-43.71	-13	-30.71	-74.91	-53.6	2.60	12.48	V	Pass	



3.7 Frequency Stability Measurement

3.7.1 Description of Frequency Stability Measurement

The frequency stability shall be measured by variation of ambient temperature and variation of primary supply voltage to ensure that the fundamental emission stays within the authorized frequency block. The frequency stability of the transmitter shall be maintained within $\pm 0.00025\%$ ($\pm 2.5\text{ppm}$) of the center frequency.

3.7.2 Measuring Instruments

The measuring equipment is listed in the section 4 of this test report.

3.7.3 Test Procedures for Temperature Variation

1. The testing follows FCC KDB 971168 v02r02 Section 9.0.
2. The EUT was set up in the thermal chamber and connected with the system simulator.
3. With power OFF, the temperature was decreased to -30°C and the EUT was stabilized before testing. Power was applied and the maximum change in frequency was recorded within one minute.
4. With power OFF, the temperature was raised in 10°C steps up to 50°C . The EUT was stabilized at each step for at least half an hour. Power was applied and the maximum frequency change was recorded within one minute.

3.7.4 Test Procedures for Voltage Variation

1. The testing follows FCC KDB 971168 v02r02 Section 9.0.
2. The EUT was placed in a temperature chamber at $25\pm 5^{\circ}\text{C}$ and connected with the system simulator.
3. The power supply voltage to the EUT was varied from BEP to 115% of the nominal value measured at the input to the EUT.
4. The variation in frequency was measured for the worst case.

3.7.5 Test Setup

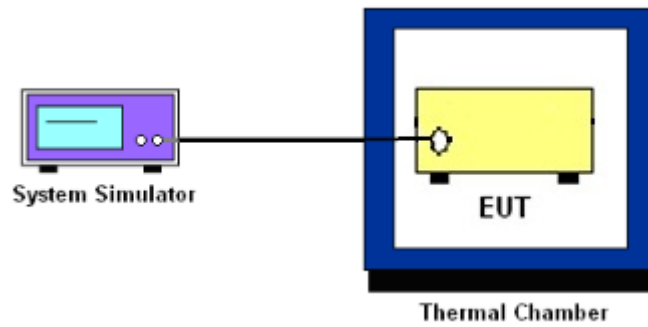



3.7.6 Test Result of Temperature Variation

Band :	GSM 850	Channel :	189
Limit (ppm) :	2.5	Frequency :	836.4 MHz

Temperature (°C)	GPRS class 8	EDGE class 8	Result
	Deviation (ppm)	Deviation (ppm)	
50	0.0036	0.0012	PASS
40	0.0072	0.0000	
30	0.0060	0.0012	
20(Ref.)	0.0000	0.0000	
10	0.0096	0.0048	
0	0.0048	0.0024	
-10	0.0060	0.0036	
-20	0.0024	0.0371	
-30	0.0036	0.0299	

Band :	GSM 1900	Channel :	661
Limit (ppm) :	within authorized band	Frequency :	1880.0 MHz

Temperature (°C)	GPRS class 8	EDGE class 8	Result
	Deviation (ppm)	Deviation (ppm)	
50	0.0059	0.0021	PASS
40	0.0037	0.0032	
30	0.0388	0.0021	
20(Ref.)	0.0000	0.0000	
10	0.0378	0.0016	
0	0.0032	0.0032	
-10	0.0021	0.0005	
-20	0.0016	0.0032	
-30	0.0021	0.0000	

Note: The frequency fundamental emissions stay within the authorized frequency block based on the frequency deviation measured is small.



Band :	WCDMA Band V	Channel :	4182
Limit (ppm) :	2.5	Frequency :	836.4 MHz

Temperature (°C)	RMC 12.2Kbps		Result
	Deviation (ppm)		
50	0.0012		PASS
40	0.0000		
30	0.0024		
20(Ref.)	0.0000		
10	0.0000		
0	0.0024		
-10	0.0227		
-20	0.0048		
-30	0.0299		

Band :	WCDMA Band IV	Channel :	1413
Limit (ppm) :	within authorized band	Frequency :	1732.6 MHz

Temperature (°C)	RMC 12.2Kbps		Result
	Deviation (ppm)		
50	0.0029		PASS
40	0.0190		
30	0.0017		
20(Ref.)	0.0000		
10	0.0023		
0	0.0185		
-10	0.0012		
-20	0.0017		
-30	0.0202		

Note: The frequency fundamental emissions stay within the authorized frequency block based on the frequency deviation measured is small.



Band :	WCDMA Band II	Channel :	9400
Limit (ppm) :	within authorized band	Frequency :	1880.0 MHz

Temperature (°C)	RMC 12.2Kbps	Result
	Deviation (ppm)	
-30	0.0176	PASS
-20	0.0011	
-10	0.0165	
0	0.0000	
10	0.0016	
20(Ref.)	0.0000	
30	0.0021	
40	0.0027	
50	0.0011	

Note: The frequency fundamental emissions stay within the authorized frequency block based on the frequency deviation measured is small.



3.7.7 Test Result of Voltage Variation

Band & Channel	Mode	Voltage (Volt)	Freq. Dev. (Hz)	Deviation (ppm)	Limit (ppm)	Result
GSM 850 CH189	GPRS class 8	13	-29	0.0012	2.5	PASS
		12	-31	0.0012		
		BEP	-28	0.0024		
	EDGE class 8	13	-16	0.0347		
		12	-19	0.0383		
		BEP	14	0.0012		
GSM 1900 CH661	GPRS class 8	13	-43	0.0011	(Note 3.)	
		12	-35	0.0032		
		BEP	31	0.0383		
	EDGE class 8	13	16	0.0207		
		12	-27	0.0021		
		BEP	-24	0.0005		
WCDMA Band V CH4182	RMC 12.2Kbps	13	-12	0.0024	2.5	
		12	-9	0.0012		
		BEP	-11	0.0012		
WCDMA Band IV CH1413	RMC 12.2Kbps	13	13	0.0173	(Note 3.)	
		12	-12	0.0029		
		BEP	-12	0.0029		
WCDMA Band II CH9400	RMC 12.2Kbps	13	-15	0.0005	(Note 3.)	
		12	-18	0.0011		
		BEP	-19	0.0016		

Note:

1. Normal Voltage = 12V.
2. Battery End Point (BEP) = 11 V.
3. The frequency fundamental emissions stay within the authorized frequency block based on the frequency deviation measured is small.



4 List of Measuring Equipment

Instrument	Manufacturer	Model No.	Serial No.	Characteristics	Calibration Date	Test Date	Due Date	Remark
System Simulator	Rohde & Schwarz	CMU200	117995	N/A	Jul. 29, 2014	Mar. 18, 2015~ Mar. 30, 2015	Jul. 28, 2015	Conducted (TH02-HY)
Spectrum Analyzer	Rohde & Schwarz	FSP40	100055	9kHz~40GHz	Jun. 09, 2014	Mar. 18, 2015~ Mar. 30, 2015	Jun. 08, 2015	Conducted (TH02-HY)
Thermal Chamber	Ten Billion	TTH-D3SP	TBN-930701	N/A	Jul. 17, 2014	Mar. 18, 2015~ Mar. 30, 2015	Jul. 16, 2015	Conducted (TH02-HY)
Signal Analyzer	Rohde & Schwarz	FSV 30	100895	9kHz ~ 30GHz	Apr. 11, 2014	Mar. 18, 2015~ Apr. 09, 2015	Apr. 10, 2015	Radiation (03CH07-HY)
Bilog Antenna	Schaffner	CBL6111C	2726	30MHz ~ 1GHz	Sep. 27, 2014	Mar. 18, 2015~ Apr. 09, 2015	Sep. 26, 2015	Radiation (03CH07-HY)
Double Ridge Horn Antenna	ESCO	3117	75962	1GHz~18GHz	Aug. 19, 2014	Mar. 18, 2015~ Apr. 09, 2015	Aug. 18, 2015	Radiation (03CH07-HY)
Preamplifier	COM-POWER	PA-103A	161241	10 MHz ~ 1000MHz	Mar. 12, 2015	Mar. 18, 2015~ Apr. 09, 2015	Mar. 11, 2016	Radiation (03CH07-HY)
Preamplifier	Agilent	8449B	3008A02362	1 GHz~26.5 GHz	Oct. 21, 2014	Mar. 18, 2015~ Apr. 09, 2015	Oct. 20, 2015	Radiation (03CH07-HY)
Turn Table	ChainTek	ChainTek 3000	N/A	0 ~ 360 degree	N/A	Mar. 18, 2015~ Apr. 09, 2015	N/A	Radiation (03CH07-HY)
Antenna Mast	ChainTek	M-400-0	114/8000604 /L	N/A	N/A	Mar. 18, 2015~ Apr. 09, 2015	N/A	Radiation (03CH07-HY)
SHF-EHF Horn Antenna	SCHWARZBEC K	BBHA 9170	BBHA91702 51	18GHz~40GHz	Oct. 02, 2014	Mar. 18, 2015~ Apr. 09, 2015	Oct. 01, 2015	Radiation (03CH07-HY)



5 Uncertainty of Evaluation

Uncertainty of Radiated Emission Measurement (30 MHz ~ 1000 MHz)

Measuring Uncertainty for a Level of Confidence of 95% ($U = 2U_c(y)$)	4.50
--	------

