



FCC 47 CFR PART 15 SUBPART C 15.247

TEST REPORT

FOR

Micro 20

Model : eXact[®] Micro 20 BT, eXact[®] EcoCheck BT,
eXact[®] Micro 10 BT, eXact[®] LeadQuick BT, eXact[®] Acustrip

Issued to

Industrial Test Systems, Inc.
1875 Langston Street, Rock Hill, SC 29730, USA

Issued by

Global Certification Corp.
No.146, Sec. 2, Xiangzhang Rd., Xizhi Dist.,New Taipei City 221,
Taiwan (R.O.C.)



Note: This test refers exclusively to the test presented test model and sample. This report shall not be reproduced except in full, without the written approval of Global Certification Corporation. This document may be altered or revised by Global Certification Corporation. Personnel only, and shall be noted in the revision section of the document.



TABLE OF CONTENTS	2
1. GENERAL INFORMATION	4
1.1 DESCRIPTION OF THE TESTED SAMPLES	5
1.2 LIST OF MEASUREMENTS AND EXAMINATIONS	6
2. TEST METHODOLOGY	7
2.1 GENERAL TEST PROCEDURES	7
2.2 FCC PART 15.205 RESTRICTED BANDS OF OPERATIONS	7
2.3 DESCRIPTION OF TEST MODES	8
2.4 DESCRIPTION OF THE SUPPORT EQUIPMENTS	8
3. TEST AND MEASUREMENT EQUIPMENT	9
3.1 CALIBRATION	9
3.2 EQUIPMENT	9
4. ANTENNA REQUIREMENTS	10
4.1 STANDARD APPLICABLE	10
4.2 ANTENNA CONSTRUCTION AND DIRECTIONAL GAIN	10
5. PEAK OUTPUT POWER	11
5.1 TEST SETUP	11
5.2 LIMIT	11
5.3 TEST PROCEDURE	11
5.4 TEST RESULT	11
5.5 TEST DATA	11
6. AVERAGE POWER	12
6.1 TEST SETUP	12
6.2 LIMIT	12
6.3 TEST PROCEDURE	12
6.4 TEST RESULT	12
6.5 TEST DATA	12
7. BAND EDGE	13
7.1 TEST SETUP	13
7.2 LIMIT	14
7.3 RESULT	14
7.4 TEST DATA	15
8. 6DB BANDWIDTH	20
8.1 TEST LIMIT	20
8.2 TEST SETUP LAYOUT	20
8.3 TEST RESULT AND DATA	20
8.4 TEST DATA	20
9. RADIATED EMISSION	22
9.1 TEST SETUP	22
9.2 LIMIT	23
9.3 TEST PROCEDURE	23
9.4 RESULT	23
9.5 TEST DATA	24
10. CONDUCTED EMISSIONS	28
10.1 TEST SETUP	28



10.2	LIMIT -----	28
10.3	TEST PROCEDURE-----	28
10.4	TEST SPECIFICATION -----	29
10.5	RESULT -----	29
10.6	TEST DATA -----	29
11.	PEAK POWER SPECTRAL DENSITY-----	30
11.1	LIMIT -----	30
11.2	TEST PROCEDURE-----	30
11.3	TEST RESULTS-----	30

APPENDIX 1

RADIO FREQUENCY EXPOSURE

APPENDIX 2

PHOTOS OF TEST CONFIGURATION

PHOTOS OF EUT



1. GENERAL INFORMATION

Applicant : Industrial Test Systems, Inc.
Address : 1875 Langston Street, Rock Hill, SC 29730, USA
Manufacturer : Metertech Inc.
Address : 63-2, Cheng Gong Road, Sec.1, NanGang, Taipei, Taiwan(R.O.C.)
EUT : Micro 20
Model No. : eXact[®] Micro 20 BT, eXact[®] EcoCheck BT, eXact[®] Micro 10 BT,
eXact[®] LeadQuick BT, eXact[®] Acustrip
Model Differences : The major electrical and mechanical constructions of series models are identical to the basic model, except different marketing purpose. The model, eXact[®] Micro 20 BT is the testing sample, and the final test data are shown on this test report.

Is here with confirmed to comply with the requirements set out in the FCC Rules and Regulations Part 15 Subpart C and the measurement procedures were according to ANSI C63.4-2009. The said equipment in the configuration described in this report shows the maximum emission levels emanating from equipment are within the compliance requirements.

FCC part 15 subpart C

Receipt Date : Jul. 16, 2014

Issue Date : Jul. 28, 2014

New Taipei City, Taiwan

(Place)

Jul. 28, 2014

(Date)

Adam Chou, Manager

(Signature)

Designation Number: TW1069



1.1 DESCRIPTION OF THE TESTED SAMPLES

EUT Name : Micro 20

Model Number : eXact[®] Micro 20 BT, eXact[®] EcoCheck BT, eXact[®] Micro 10 BT, eXact[®] LeadQuick BT, eXact[®] Acustrip

FCC ID : 2ADOEM20BT1

Input Voltage : 3Vdc

Power From : Inside Outside
Adapter
Battery :6Vdc
AC Power Source
DC Power Source
Support Unit PC

Operate Frequency : Refer to the channel list as described below
2.4GHz

Modulation Technique : GFSK

Number of Channels : 40

Channel spacing : 1MHz

Operating Mode : Duplex

Antenna Type : PCB (Inverted-F)

Antenna gain : -5.45 dBi

Channels	Frequencies (MHz)	Channels	Frequencies (MHz)	Channels	Frequencies (MHz)	Channels	Frequencies (MHz)
0	2402	10	2422	20	2442	30	2462
1	2404	11	2424	21	2444	31	2464
2	2406	12	2426	22	2446	32	2466
3	2408	13	2428	23	2448	33	2468
4	2410	14	2430	24	2450	34	2470
5	2412	15	2432	25	2452	35	2472
6	2414	16	2434	26	2454	36	2474
7	2416	17	2436	27	2456	37	2476
8	2418	18	2438	28	2458	38	2478
9	2420	19	2440	29	2460	39	2480



1.2 LIST OF MEASUREMENTS AND EXAMINATIONS

FCC Rule	Description of Test	Result
15.203	Antenna Requirement	Pass
15.207	Conducted Emission	N/A
15.209	Radiated Emission	Pass
15.247(a)(1)	6dB Bandwidth Measurement	Pass
15.247(a)(1)	Peak power spectral density	Pass
15.247(b)	Peak Output Power Measurement Data	Pass
15.247(b)	Band Edges Measurement Data	Pass



2. TEST METHODOLOGY

All testing as described bellowed were performed in accordance with ANSI C63.4:2009and FCC CFR 47 Part 15 Subpart C.

2.1 GENERAL TEST PROCEDURES

Conducted Emissions

The EUT is placed on a wood table, which is at 0.8 m above ground plane acceding to clause 15.207 and requirements of ANSI C63.4:2009. Conducted emissions from the EUT measured in the frequency range between 0.15 MHz and 30MHz are using CISPR Quasi-Peak / Average detectors.

Radiated Emissions

The EUT is a placed on a turn table, which is 0.8 m above ground plane. The turntable was rotated through 360 degrees to determine the position of maximum emission level. The EUT is placed at 3m away from the receiving antenna, which varied from 1m to 4m to find out the highest emission. Each emission was to be maximized by changing the polarization of receiving antenna both horizontal and vertical.

2.2 FCC PART 15.205 RESTRICTED BANDS OF OPERATIONS

(a) Except as shown in paragraph (d) of this section, only spurious emissions are permitted in any of the frequency bands listed below:

MHz	MHz	MHz	GHz
0.090 - 0.110	16.42 - 16.423	399.9 - 410	4.5 - 5.15
10.495 - 0.505	16.69475 - 16.69525	608 - 614	5.35 - 5.46
2.1735 - 2.1905	16.80425 - 16.80475	960 - 1240	7.25 - 7.75
4.125 - 4.128	25.5 - 25.67	1300 - 1427	8.025 - 8.5
4.17725 - 4.17775	37.5 - 38.25	1435 - 1626.5	9.0 - 9.2
4.20725 - 4.20775	73 - 74.6	1645.5 - 1646.5	9.3 - 9.5
6.215 - 6.218	74.8 - 75.2	1660 - 1710	10.6 - 12.7
6.26775 - 6.26825	108 - 121.94	1718.8 - 1722.2	13.25 - 13.4
6.31175 - 6.31225	123 - 138	2200 - 2300	14.47 - 14.5
8.291 - 8.294	149.9 - 150.05	2310 - 2390	15.35 - 16.2
8.362 - 8.366	156.52475 - 156.52525	2483.5 - 2500	17.7 - 21.4
8.37625 - 8.38675	156.7 - 156.9	2655 - 2900	22.01 - 23.12
8.41425 - 8.41475	162.0125 - 167.17	3260 - 3267	23.6 - 24.0
12.29 - 12.293	167.72 - 173.2	3332 - 3339	31.2 - 31.8
12.51975 - 12.52025	240 - 285	3345.8 - 3358	36.43 - 36.5
12.57675 - 12.57725	322 - 335.4	3600 - 4400	(²)
13.36 - 13.41			

1 Until February 1, 1999, this restricted band shall be 0.490-0.510 MHz.

2 Above 38.6

(b) Except as provided in paragraphs (d) and (e), the field strength of emissions appearing within these frequency bands shall not exceed the limits shown in Section 15.209. At frequencies equal to or less than 1000 MHz, compliance with the limits in Section 15.209



shall be demonstrated using measurement instrumentation employing a CISPR quasi-peak detector. Above 1000 MHz, compliance with the emission limits in Section 15.209 shall be demonstrated based on the average value of the measured emissions. The provisions in Section 15.35 apply to these measurements.

2.3 DESCRIPTION OF TEST MODES

The EUT was tested under following modes:

Modes:

1. Full System

Channels:

1. 2.402GHz (Lowest Channel)
2. 2.440GHz (Middle Channel)
3. 2.480GHz (Highest Channel)

2.4 DESCRIPTION OF THE SUPPORT EQUIPMENTS

Setup Diagram

See test photographs attached in *appendix 1* for the actual connections between EUT and support equipment.



Support Equipment

Peripherals Devices:

OUTSIDE SUPPORT EQUIPMENT							
No.	Equipment	Model	Serial No.	FCC ID/ BSMI ID	Trade name	Data Cable	Power Cord
1.	N/A	N/A	N/A	N/A	N/A	N/A	N/A
EUT							
No.	Equipment	Model	Serial No.	FCC ID/ BSMI ID	Trade name	Data Cable	Power Cord
1.	PCB	UPC-1-V0	N/A	N/A	N/A	N/A	N/A

Note: All the above equipment /cable were placed in worse case position to maximize emission signals during emission test

Grounding: Grounding was in accordance with the manufacturer’s requirement and conditions for the intended use.



3. TEST AND MEASUREMENT EQUIPMENT

3.1 CALIBRATION

The measuring equipment utilized to perform the tests documented in the report has been calibrated once a year or in accordance with the manufacturer's recommendations, and is traceable to recognized national standards.

3.2 EQUIPMENT

The following list contains measurement equipment used for testing. The equipment conforms to the requirement of CISPR 16-1, ANSI C63.2 and. Other required standards.

Calibration of all test and measurement, including any accessories that may effect such calibration, is checked frequently to ensure the accuracy. Adjustments are made and correction factors are applied in accordance with the instructions contained in the respective.

TABLE 1 LIST OF TEST AND MEASUREMENT EQUIPMENT

Instrument	Manufacturer	Model No.	Serial No.	Calibration Due Date	Note
EMC Test Receiver	R&S	ESCI	100438	Aug. 28, 2014	
Bilog Antenna	SUNOL	JB1	A052204	Nov. 21, 2014	
Turn table	EMCO	2080	9508-1805	N/A	
Controller	EMCO	2090	9804-1328	N/A	
RF Cable	JYE BAO	RG214/U	Cable-002	Nov. 22, 2014	
Thermo-Hygro meter	WISEWIND	4-IN-1	050100378	Apr. 08, 2015	
Wideband Peak Power Meter	Anritsu	ML2495A	0841006	Oct. 03, 2014	
Pre-Amplifier	WIRELESS	FPA-6592G	60028	Sep. 06, 2014	
Microwave Preamplifier	EMC INSTRUMENT	EMC051845	980059	Dec. 05, 2014	
EMC Test Receiver	LIG	ER-265	L0907B006	Nov. 22, 2014	
RF Cable_NSA_Rx	HUBER + UHNER	RG213/U	Cable-004	May 21, 2015	
Double Ridged Guide HORN ANTENNA	EST.LINDGREN	3117	00119028	May. 21, 2015	
Microwave Cable	HUBER SUHNER	SUCOFLEX 104	Cable-003-4M	Dec. 05, 2014	
Microwave Cable	HUBER SUHNER	SUCOFLEX 104	Cable-003-3M	Dec. 03, 2014	

✧ Calibration interval of instruments listed above is one year



4. ANTENNA REQUIREMENTS

4.1 STANDARD APPLICABLE

For intentional device, according to FCC 47 CFR Section 15.203, an intentional radiator shall be designed to ensure that no antenna other than that furnished by the responsible party shall be used with the device.

And according to FCC 47 CFR Section 15.247(b), if transmitting antennas of direction gain greater than 6dBi are used, the power shall be reduced by the amount in dB that the directional gain of the antenna exceeds 6dBi.

4.2 ANTENNA CONSTRUCTION AND DIRECTIONAL GAIN

Antenna type: PCB (Inverted-F)

Antenna Gain: -5.45 dBi



5. PEAK OUTPUT POWER

5.1 TEST SETUP

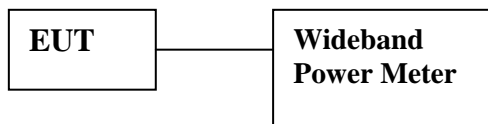

5.2 LIMIT

The maximum peak output power of the intentional radiator shall not exceed the following:

1. According to § 15.247(b)(3) , for systems using digital modulation in the bands of 902 – 928 MHz , 2400 – 2483.5 MHz: 1 Watt.
2. According to § 15.247(b)(4) , the conducted output power limit specified in paragraph (b) of this section is based on the use of antennas with directional gains that do not exceed 6 dBi. Except as shown in paragraph (c) of this section , if transmitting antennas of directional gain greater than 6 dBi are used , the conducted output power from the intentional radiator shall be reduced below the stated values in paragraphs (b)(1) , (b)(2) , and (b)(3) of this section , as appropriate , by the amount in dB that directional gain of the antenna exceeds 6 dBi.

5.3 TEST PROCEDURE

1. Peak power is measured using the wideband power meter.
2. Power is integrated over a bandwidth greater than or equal to the 99% bandwidth.

5.4 TEST RESULT: PASS

5.5 TEST DATA:

Channel No.	Frequency (MHz)	Measurement Level (dbm)	Required Limit (dbm)	Result
0	2402	-15.03	< 30 dbm	PASS
39	2440	-16.81	< 30 dbm	PASS
78	2480	-16.15	< 30 dbm	PASS



6. AVERAGE POWER

6.1 TEST SETUP

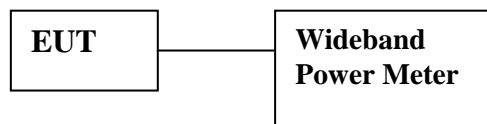

6.2 LIMIT

None ; for reporting purposes only.

6.3 TEST PROCEDURE

The transmitter output is connected to the Power Meter. The Power Meter is set to the average power detection.

6.4 TEST RESULT: PASS

6.5 TEST DATA:

Channel No.	Frequency (MHz)	Measurement Level (dbm)	Required Limit (dbm)	Result
0	2402	-14.57	< 30 dbm	PASS
39	2440	-16.08	< 30 dbm	PASS
78	2480	-17.49	< 30 dbm	PASS

7. BAND EDGE

7.1 TEST SETUP

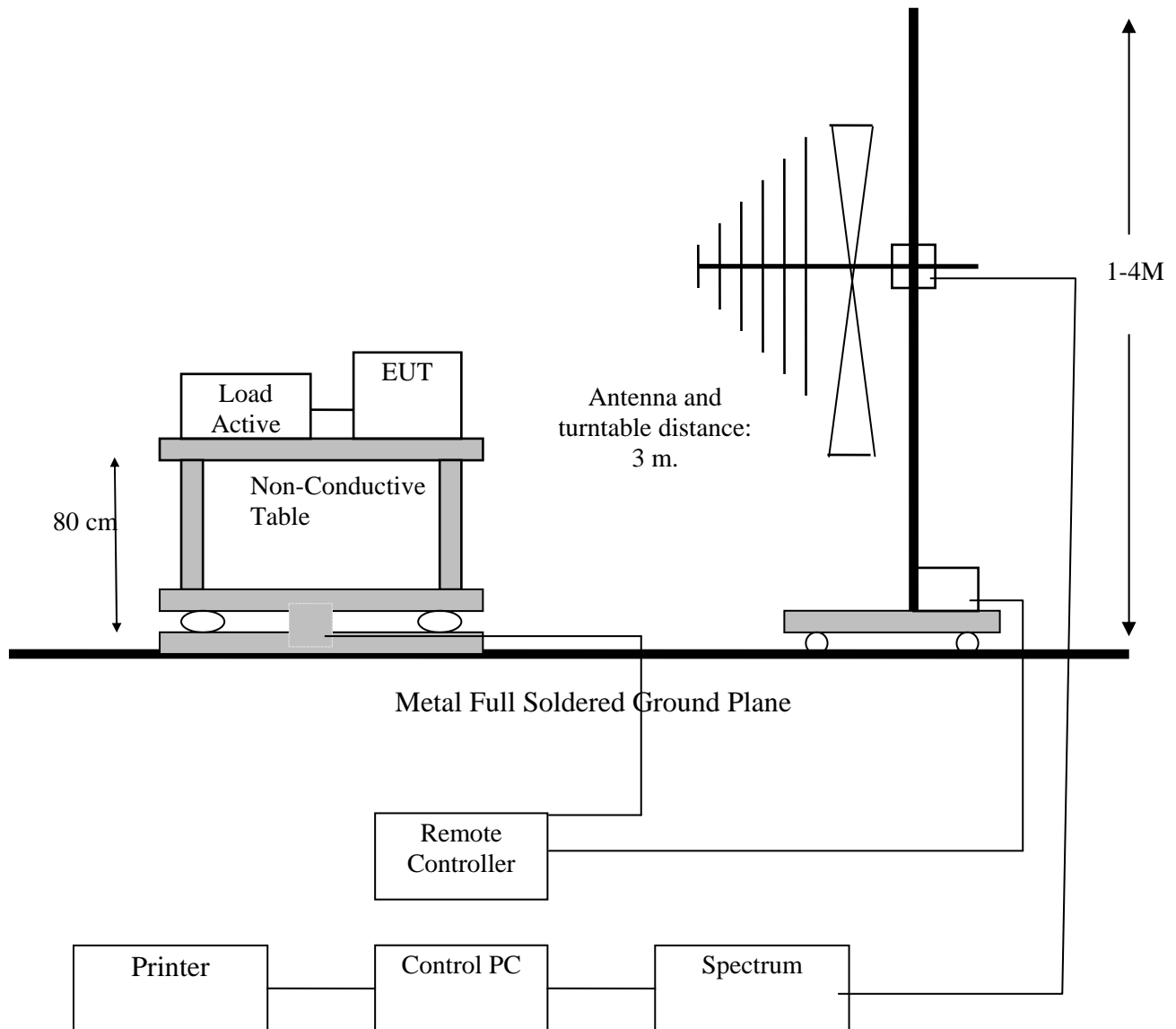



7.2 LIMIT

Restricted Bands:

MHz	MHz	MHz	GHz
0.090 - 0.110	16.42 - 16.423	399.9 - 410	4.5 - 5.15
¹ 0.495 - 0.505	16.69475 - 16.69525	608 - 614	5.35 - 5.46
2.1735 - 2.1905	16.80425 - 16.80475	960 - 1240	7.25 - 7.75
4.125 - 4.128	25.5 - 25.67	1300 - 1427	8.025 - 8.5
4.17725 - 4.17775	37.5 - 38.25	1435 - 1626.5	9.0 - 9.2
4.20725 - 4.20775	73 - 74.6	1645.5 - 1646.5	9.3 - 9.5
6.215 - 6.218	74.8 - 75.2	1660 - 1710	10.6 - 12.7
6.26775 - 6.26825	108 - 121.94	1718.8 - 1722.2	13.25 - 13.4
6.31175 - 6.31225	123 - 138	2200 - 2300	14.47 - 14.5
8.291 - 8.294	149.9 - 150.05	2310 - 2390	15.35 - 16.2
8.362 - 8.366	156.52475 - 156.52525	2483.5 - 2500	17.7 - 21.4
8.37625 - 8.38675	156.7 - 156.9	2690 - 2900	22.01 - 23.12
8.41425 - 8.41475	162.0125 - 167.17	3260 - 3267	23.6 - 24.0
12.29 - 12.293	167.72 - 173.2	3332 - 3339	31.2 - 31.8
12.51975 - 12.52025	240 - 285	3345.8 - 3358	36.43 - 36.5
12.57675 - 12.57725	322 - 335.4	3600 - 4400	(²)
13.36 - 13.41			

Operation within the bands:

902 - 928 MHz, 2400 - 2483.5 MHz, 5725 - 5875 MHz, and 24.0 - 24.25 GHz.

Frequency (Hz)	Field Strength (μ V/m at 3-meter)	Field Strength (dB μ V/m at 3-meter)
1.705-30	30 (at 30-meter)	69.54
30-88	100	40
88-216	150	43
216-960	200	46
Above 960	500	54

7.3 RESULT: PASS



7.4 TEST DATA:

Lowest Channel- Horizontal



Global Certification Corp.
環球認證有限公司
No.146, Sec. 2, Xiangzhang Rd.,
Xizhi Dist., New Taipei City 221, Taiwan (R.O.C.)
Global Certification Corp. TEL:886-2-26426992 FAX:886-2-26487450

Data:5

File:C:\Users\GCC\Desktop\e3 DATA\報告\471601-RE(1G-6G).EM6

Time:14:40:57

Date:2014-7-21

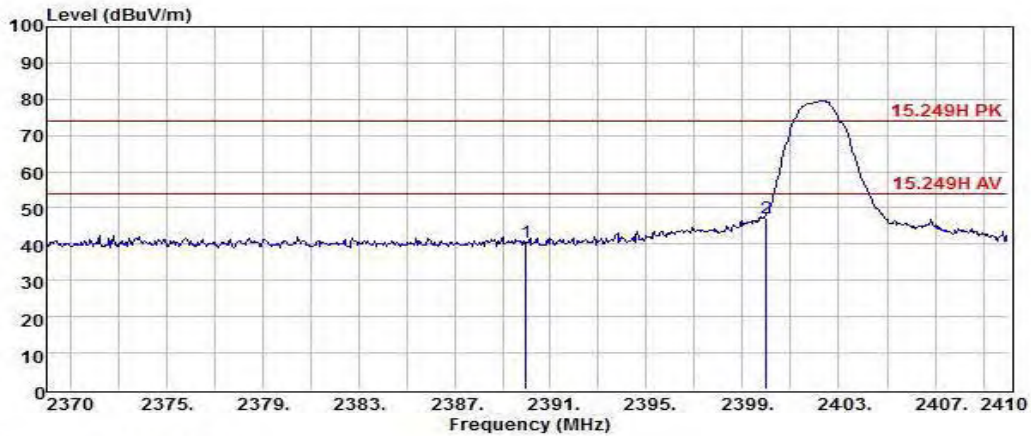

Site : GCC_RE-02
 Condition : 15.249H PK HORIZONTAL
 : RBW:1000 VBW:1000
 EUT : See Page 1 of EMC Report
 MODEL : See Page 1 for Details
 MEMO : 3Vdc 21 °C 54%
 T/H : CH L
 :
 :

	Meter	System	Cable	Antenna	Preamp	Real	Limit	Over	
Freq	Level	Factor	Loss	Factor	Gain	Level	Line	Limit	Remark
MHz	dBuV	dB/m	dB	dB/m	dB	dBuV/m	dBuV/m	dB	
1 2390.00	59.33	-18.86	5.09	31.65	55.60	40.47	74.00	-33.53	Peak
2 2400.00	66.12	-18.84	5.10	31.66	55.60	47.28	74.00	-26.72	Peak

System Factor = Cable Loss + Antenna Factor - Preamp Gain
 Real Level = Meter Level + System Factor
 Over Limit = Real Level - Limit Line



Lowest Channel-Vertical



Global Certification Corp.
環球認證有限公司
No.146, Sec. 2, Xiangzhang Rd.,
Xizhi Dist., New Taipei City 221, Taiwan (R.O.C.)
Global Certification Corp. TEL:886-2-26426992 FAX:886-2-26487450

Data:2

File:C:\Users\GCC\Desktop\e3 DATA\報告\471601-RE (1G-6G) .EM6

Time:14:36:25

Date:2014-7-21

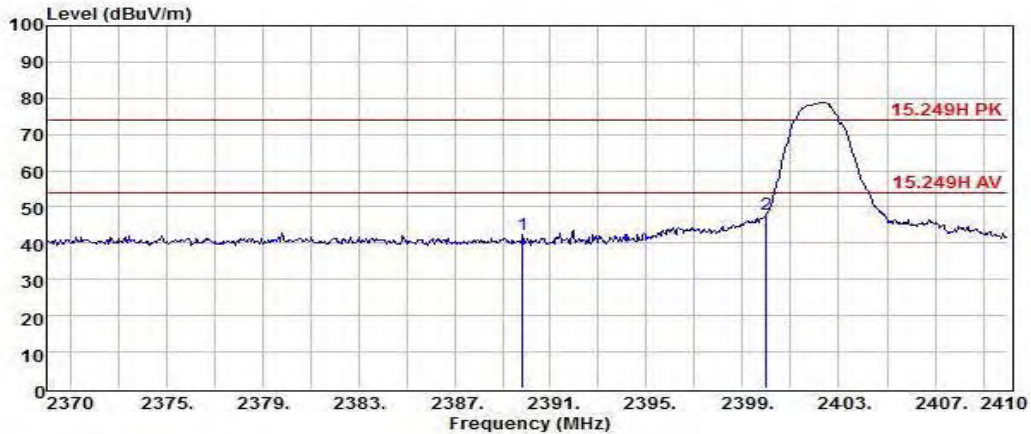

Site : GCC_RE-02
 Condition : 15.249H PK VERTICAL
 : RBW:1000 VBW:1000
 EUT : See Page 1 of EMC Report
 MODEL : See Page 1 for Details
 MEMO : 3Vdc 21 °C 54%
 T/H : CH L
 :
 :

	Freq	Meter Level	System Factor	Cable Loss	Antenna Factor	Preamp Gain	Real Level	Limit Line	Over Limit	Remark
	MHz	dBuV	dB/m	dB	dB/m	dB	dBuV/m	dBuV/m	dB	
1	2389.84	61.07	-18.86	5.09	31.65	55.60	42.21	74.00	-31.79	Peak
2	2400.00	66.86	-18.84	5.10	31.66	55.60	48.02	74.00	-25.98	Peak

System Factor = Cable Loss + Antenna Factor - Preamp Gain
 Real Level = Meter Level + System Factor
 Over Limit = Real Level - Limit Line



Highest Channel- Horizontal



Global Certification Corp.
No.146, Sec. 2, Xiangzhang Rd.,
Xizhi Dist., New Taipei City 221, Taiwan (R.O.C.)
TEL:886-2-26426992 FAX:886-2-26487450

Data:15

File:C:\Users\GCC\Desktop\e3 DATA\報告\471601-RE(1C-6G).EM6

Time:14:55:38

Date:2014-7-21

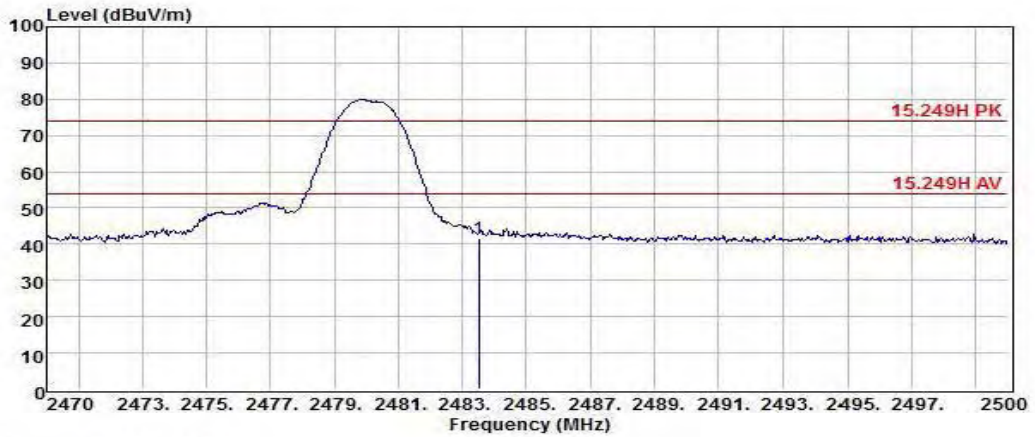

Site : GCC_RE-02
 Condition : 15.249H PK HORIZONTAL
 : RBW:1000 VBW:1000
 EUT : See Page 1 of EMC Report
 MODEL : See Page 1 for Details
 MEMO : 3Vdc 21 °C 54%
 T/H : CH H
 :

	Meter	System	Cable	Antenna	Preamp	Real	Limit	Over	
Freq	Level	Factor	Loss	Factor	Gain	Level	Line	Limit	Remark
MHz	dBuV	dB/m	dB	dB/m	dB	dBuV/m	dBuV/m	dB	
1 2483.50	60.33	-18.59	5.19	31.78	55.56	41.74	74.00	-32.26	Peak

System Factor = Cable Loss + Antenna Factor - Preamp Gain
 Real Level = Meter Level + System Factor
 Over Limit = Real Level - Limit Line



Highest Channel- Vertical



Global Certification Corp.
環球認證有限公司
Global Certification Corp.
No.146, Sec. 2, Xiangzhang Rd.,
Xizhi Dist., New Taipei City 221, Taiwan (R.O.C.)
TEL:886-2-26426992 FAX:886-2-26487450

Data:12

File:C:\Users\GCC\Desktop\e3 DATA\報告\471601-RE(1G-6G).EM6

Time:14:47:37

Date:2014-7-21

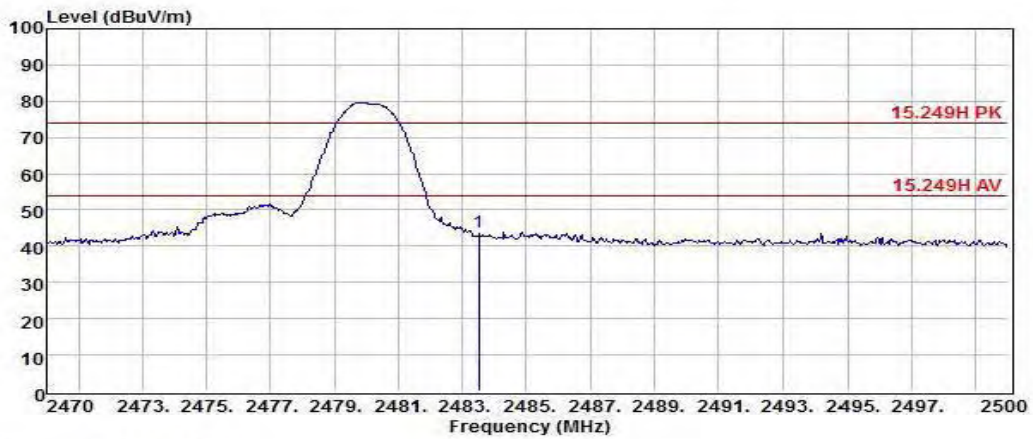

Site : GCC_RE-02
Condition : 15.249H PK VERTICAL
: RBW:1000 VBW:1000
EUT : See Page 1 of EMC Report
MODEL : See Page 1 for Details
MEMO : 3Vdc 21 °C 54%
T/H : CH H
:
:

	Meter	System	Cable	Antenna	Preamp	Real	Limit	Over	
	Freq	Level	Factor	Loss	Factor	Gain	Level	Line	Limit Remark
	MHz	dBuV	dB/m	dB	dB/m	dB	dBuV/m	dBuV/m	dB
1	2483.50	62.34	-18.59	5.19	31.78	55.56	43.75	74.00	-30.25 Peak

System Factor = Cable Loss + Antenna Factor - Preamp Gain
Real Level = Meter Level + System Factor
Over Limit = Real Level - Limit Line



Note:

1. Emission level = Reading level + Correction factor
2. Correction factor = Antenna factor + Cable loss – Preamp factor.
3. All emissions as described above were determining by rotating the EUT through three orthogonal axes to maximizing the emissions if the EUT belongs to hand-held or body-worn devices.
4. Measurements above 1000 MHz, Peak detector setting: use a 1 MHz RBW, a 3 MHz VBW.
5. Measurements above 1000 MHz, Average detector setting: 1 MHz RBW with 10 Hz VBW.
6. Peak detector measurement data will represent the worst case results.



8. 6DB BANDWIDTH

8.1 TEST LIMIT

According to §15.247(a)(2) & RSS-210 §A8.2(a), systems using digital modulation techniques may operate in the 902 - 928 MHz, 2400 - 2483.5 MHz, and 5725 - 5850 MHz bands. The minimum 6dB bandwidth shall be at least 500 kHz.

8.2 TEST SETUP LAYOUT

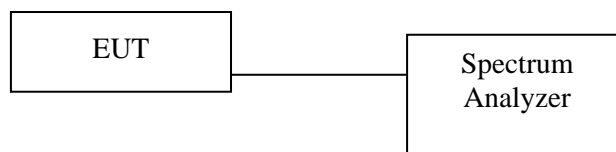

8.3 TEST RESULT AND DATA

Channel	Frequency (MHz)	6dB Bandwidth (KHz)	Limit (KHz)	Result
0	2402	669KHz	>500	PASS
39	2440	662KHz		PASS
78	2480	658KHz		PASS

8.4 TEST DATA:

LOW FREQUENCY

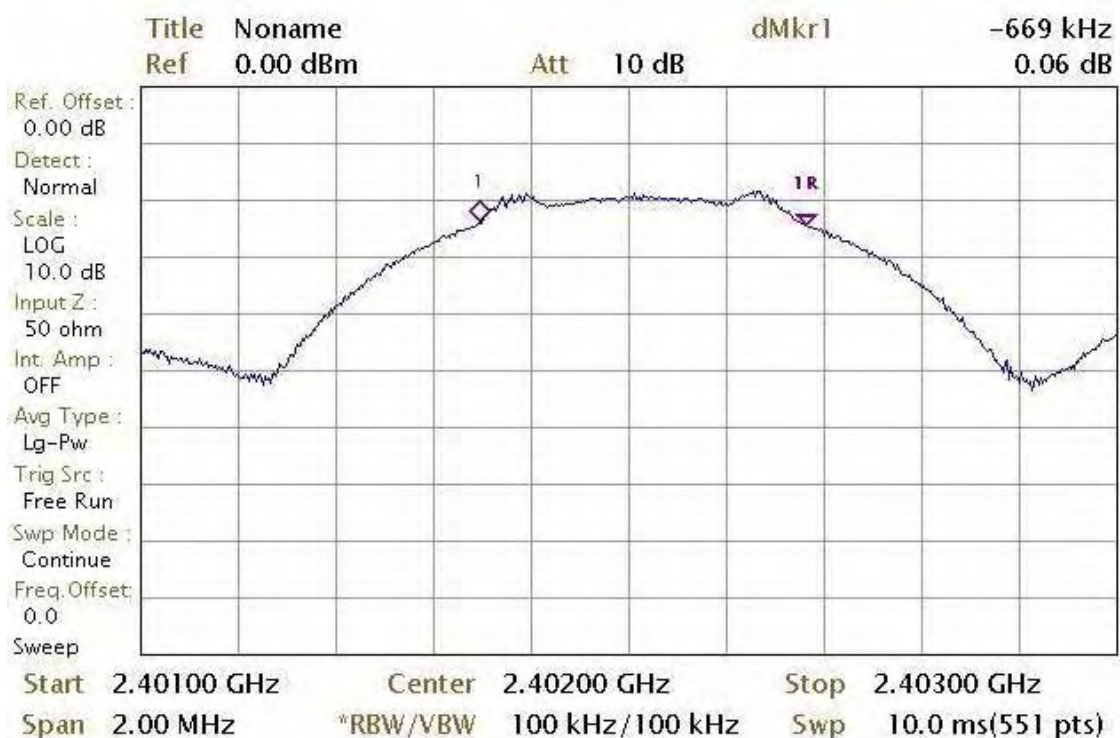



MIDDLE FREQUENCY

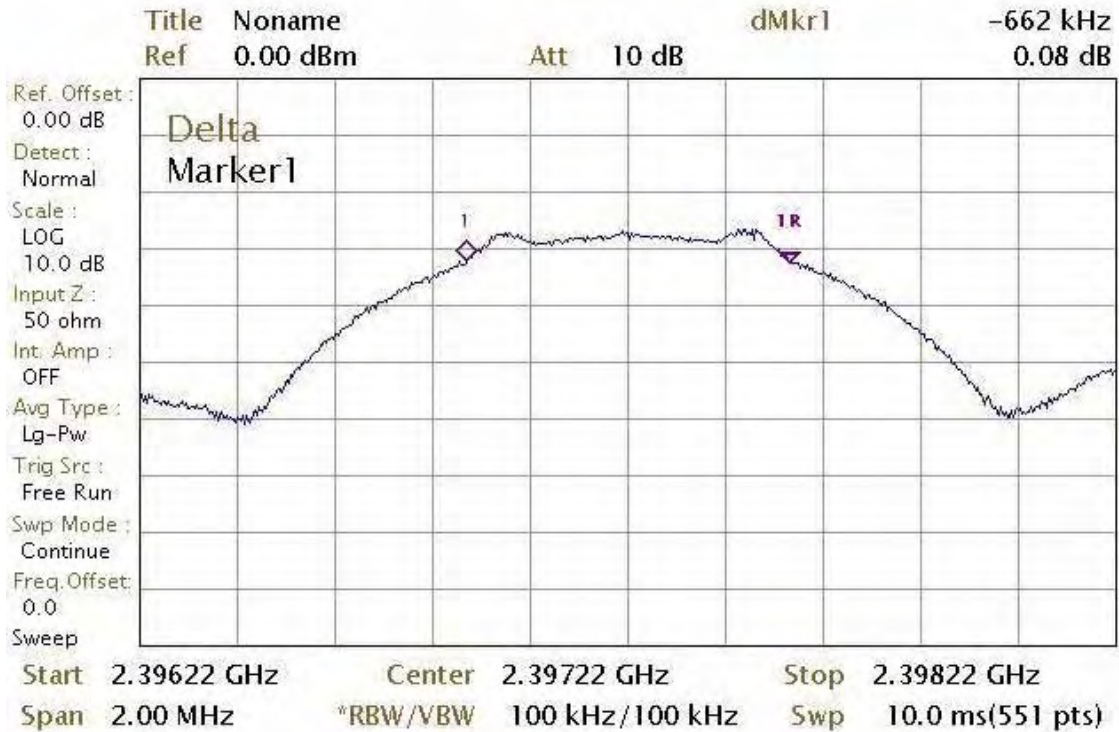

HIGH FREQUENCY

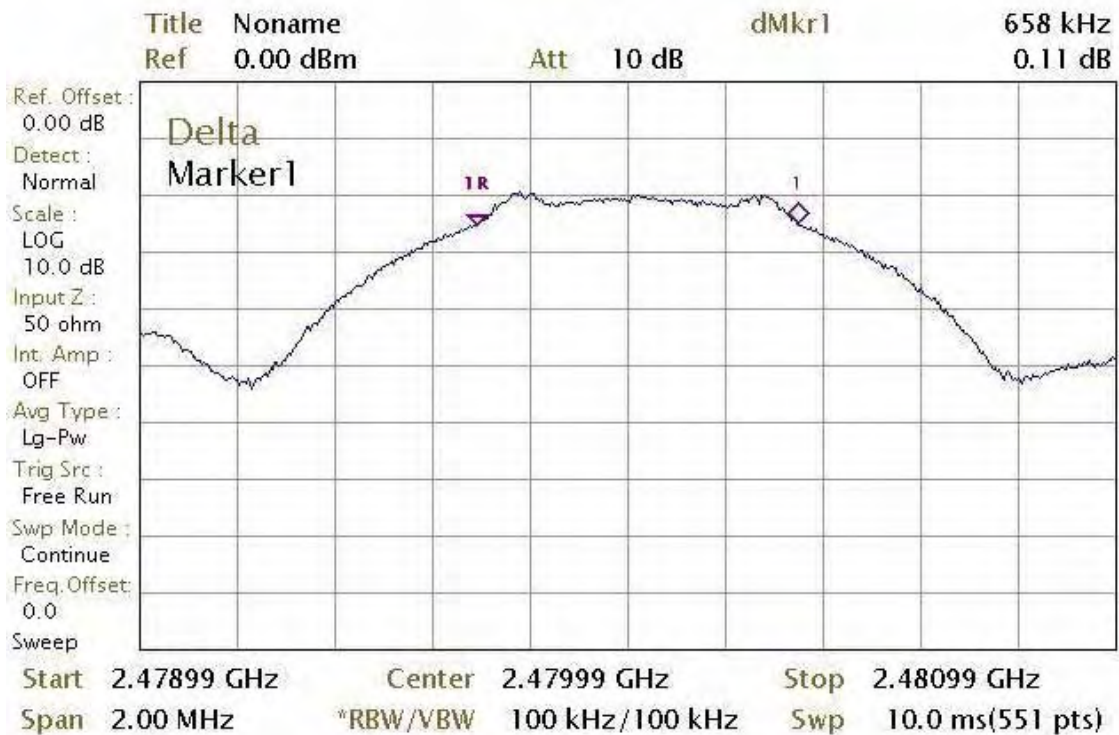

9. RADIATED EMISSION

9.1 TEST SETUP

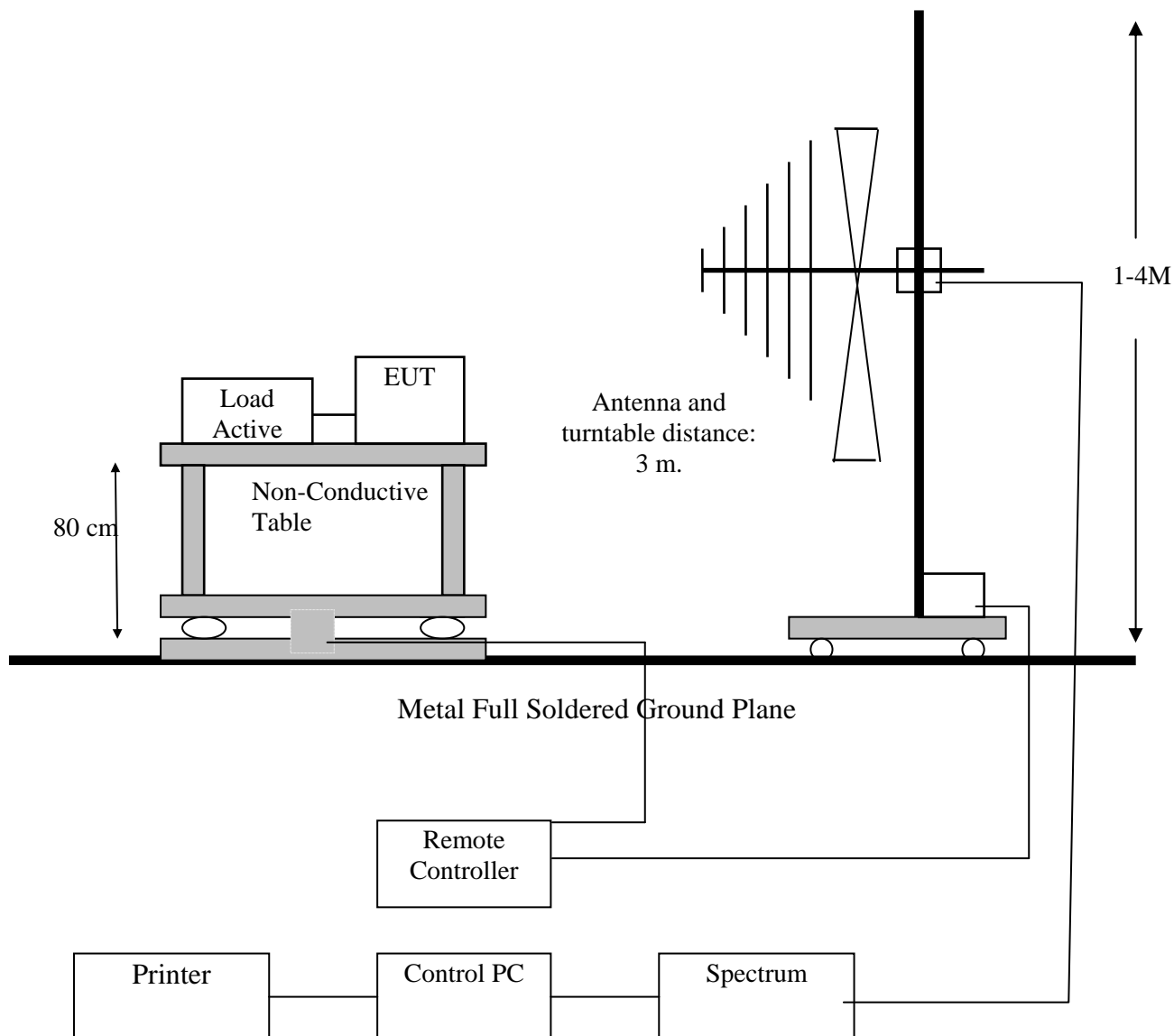



9.2 LIMIT

The field strength of any emissions which appear outside of this band shall not exceed the general radiated emission limits in section 15.209 as below.

Frequency (MHz)	Field Strength (mV/m)	Measurement Distance (m)
1.705-30	30	30
30-88	100*	3
88-216	150*	3
216-960	200*	3
Above 960	500*	3

**Except as provided in paragraph (g), fundamental emissions from intentional radiators operating under this Section shall not be located in the frequency bands 54-72 MHz, 76-88 MHz, 174-216 MHz or 470-806 MHz. However, operation within these frequency bands is permitted under other sections of this Part, e.g., Sections 15.231 and 15.241.*

In the above emission table, the tighter limit applies at the band edges.

Frequency (Hz)	Field Strength ($\mu\text{V/m}$ at 3-meter)	Field Strength (dB $\mu\text{V/m}$ at 3-meter)
1.705-30	30 (at 30-meter)	69.54
30-88	100	40
88-216	150	43
216-960	200	46
Above 960	500	54

9.3 TEST PROCEDURE

- 1、 The EUT was placed on a turntable, which was 0.8m above ground plane.
- 2、 The turntable was rotated for 360 degrees to determine the position of maximum emission level.
- 3、 EUT was set at 3m away from the receiving antenna, which was varied from 1m to 4m to find out the highest emissions.
- 4、 Maximum procedure was performed on the six highest emissions to ensure EUT compliance.
- 5、 And also, each emission was maximized by changing the polarization of receiving antenna, both horizontal and vertical.
- 6、 Repeated above procedures until the measurements for all frequencies are completed.

9.4 RESULT: PASS



9.5 TEST DATA:

All frequencies not described in this test report and within the range of the general radiated emission limits are not detectable significantly. The table as below is representing worst emissions found.

Lowest Channel (worst emissions found)

Horizontal

Frequency (MHz)	Reading (dBuV)	Correction factor(dB)	Spurious Emissions (dBuV/m)	Limit (dBuV/m)	Remark
31.94	25.75	-7.90	17.84	40.00	Peak
58.13	37.66	-20.22	17.44	40.00	Peak
96.93	35.25	-17.86	17.39	43.00	Peak
125.06	35.70	-13.29	22.41	43.00	Peak
148.34	31.60	-14.49	17.11	43.00	Peak
257.95	27.93	-14.51	13.42	46.00	Peak
4742.50	55.93	-14.91	41.02	74.00	Peak
7300.00	52.51	-11.19	41.32	74.00	Peak
9587.50	56.75	-9.73	47.02	74.00	Peak

Vertical

Frequency (MHz)	Reading (dBuV)	Correction factor(dB)	Spurious Emissions (dBuV/m)	Limit (dBuV/m)	Remark
112.45	38.57	-14.16	24.41	43.00	Peak
125.06	39.46	-13.29	26.17	43.00	Peak
167.74	36.63	-15.25	21.38	43.00	Peak
224.00	40.59	-15.66	24.93	46.00	Peak
319.06	29.38	-12.43	16.95	46.00	Peak
398.60	30.60	-10.23	20.37	46.00	Peak
4810.00	58.14	-14.84	43.30	74.00	Peak
7262.50	52.61	-11.20	41.41	74.00	Peak
9647.50	54.28	-9.69	44.59	74.00	Peak



Middle Channel

Horizontal

Frequency (MHz)	Reading (dBuV)	Correction factor(dB)	Spurious Emissions (dBuV/m)	Limit (dBuV/m)	Remark
56.19	37.27	-20.11	17.16	40.00	Peak
123.12	34.87	-13.26	21.61	43.00	Peak
222.06	27.41	-15.69	11.72	46.00	Peak
319.06	29.04	-12.43	16.61	46.00	Peak
419.94	27.04	-9.67	17.37	46.00	Peak
491.72	27.90	-7.72	20.18	46.00	Peak
4817.50	55.58	-14.82	40.76	74.00	Peak
7487.50	52.26	-11.10	41.16	74.00	Peak
9535.00	55.65	-9.76	45.89	74.00	Peak

Vertical

Frequency (MHz)	Reading (dBuV)	Correction factor(dB)	Spurious Emissions (dBuV/m)	Limit (dBuV/m)	Remark
40.67	39.09	-14.54	24.55	40.00	Peak
112.45	38.20	-14.16	24.04	43.00	Peak
131.85	38.12	-13.50	24.62	43.00	Peak
224.00	40.78	-15.66	25.12	46.00	Peak
319.06	29.51	-12.43	17.08	46.00	Peak
398.60	29.79	-10.23	19.56	46.00	Peak
4915.00	60.13	-14.70	45.43	74.00	Peak
7960.00	56.16	-10.89	45.27	74.00	Peak
9602.50	58.35	-9.72	48.63	74.00	Peak



Highest Channel

Horizontal

Frequency (MHz)	Reading (dBuV)	Correction factor(dB)	Spurious Emissions (dBuV/m)	Limit (dBuV/m)	Remark
56.19	37.62	-20.11	17.51	40.00	Peak
123.12	34.52	-13.26	21.26	43.00	Peak
199.75	26.39	-14.60	11.79	46.00	Peak
299.66	28.51	-12.94	15.57	46.00	Peak
319.06	28.81	-12.43	16.38	46.00	Peak
454.86	26.70	-8.72	17.98	46.00	Peak
4990.00	59.14	-14.62	44.52	74.00	Peak
8237.50	55.39	-10.80	44.59	74.00	Peak
9760.00	56.93	-9.63	47.30	74.00	Peak

Vertical

Frequency (MHz)	Reading (dBuV)	Correction factor(dB)	Spurious Emissions (dBuV/m)	Limit (dBuV/m)	Remark
40.67	39.04	-14.54	24.5	40.00	Peak
111.48	40.15	-14.27	25.88	43.00	Peak
224.00	41.02	-15.66	25.36	46.00	Peak
319.06	31.03	-12.43	18.60	46.00	Peak
442.25	26.46	-9.06	17.40	46.00	Peak
555.74	27.66	-6.32	21.34	46.00	Peak
4997.50	58.37	-14.60	43.77	74.00	Peak
7990.00	56.56	-10.87	45.69	74.00	Peak
9880.00	57.43	-9.54	47.89	74.00	Peak



Note:

1. Emission level = Reading level + Correction factor
2. Correction factor: Antenna factor + Cable loss – Preamp factor.
3. All emissions as described above were determining by rotating the EUT through three orthogonal axes to maximizing the emissions if the EUT belongs to hand-held or body-worn devices.
4. Measurements from 9 kHz to 150 kHz, Peak detector setting: 100 Hz RBW
5. Measurements from 150 kHz to 30MHz, Peak detector setting: 10 kHz RBW
6. Measurements from 30 MHz to 1000 MHz, Peak detector setting: 100 kHz RBW
7. Measurements from 9 kHz to 150 kHz, CISPR Quasi-Peak detector: 200 Hz RBW
8. Measurements from 150 kHz to 30MHz, CISPR Quasi-Peak detector: 9 kHz RBW
9. Measurements from 30 MHz to 1000 MHz, CISPR Quasi-Peak detector: 120 kHz RBW
10. Peak detector measurement data will represent the worst case results.



10. CONDUCTED EMISSIONS

10.1 TEST SETUP

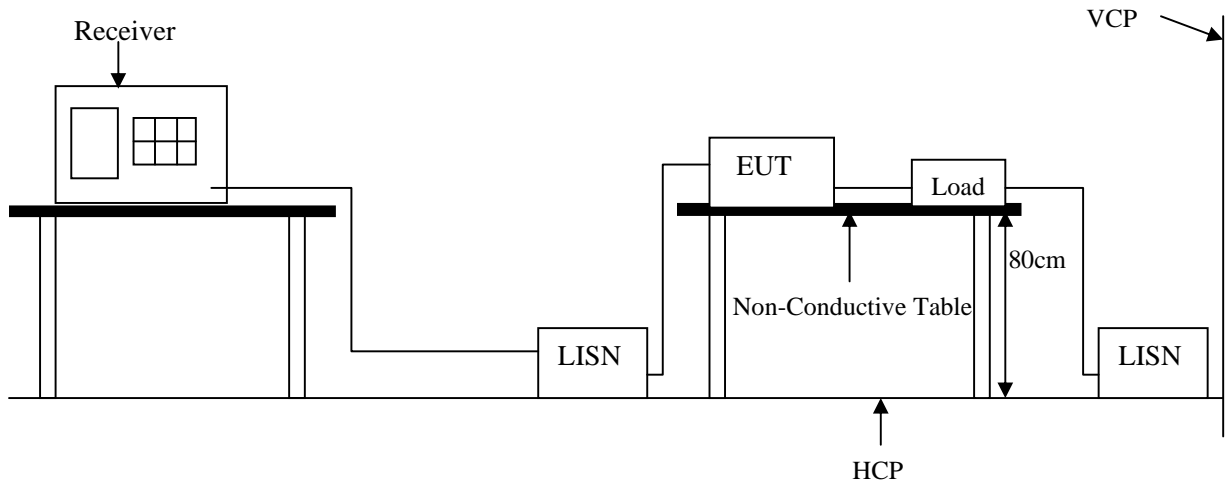

10.2 LIMIT

Frequency range (MHz)	CLASS A		CLASS B	
	QP dB(uV)	Average dB(uV)	QP dB(uV)	Average dB(uV)
0.15-0.5	79 dBuV	66 dBuV	66 - 56 dBuV	56 - 46 dBuV
0.5-5.0	73 dBuV	60 dBuV	56 dBuV	46 dBuV
5.0-30.0	73 dBuV	60 dBuV	60 dBuV	50 dBuV

Remark: In the above table, the tighter limit applies at the band edges.

10.3 TEST PROCEDURE

The EUT and simulators are connected to the main power through a line impedance stabilization network (LISN). It provides a 50 ohm / 50 μ H coupling impedance for the measuring equipment. The peripheral devices are also connected to the main power through a LISN that provides a 50 ohm / 50 μ H coupling impedance with 50 ohm termination. (Please refer to the block diagram of the test setup and photograph.)

Both sides of AC line are checked for the maximum conducted emission interference. In order to find the maximum emissions, the relating positions of equipment and all of the interference cables must be changed according to EN 55022 regulations: The measurement procedure on conducted emission interference.

The resolution bandwidth of the field strength meter is set at 9 KHz.



10.4 TEST SPECIFICATION

According to PART 15.207

10.5 RESULT:

Not applicable, because the EUT doesn't connect with the AC power source directly.

10.6 TEST DATA: N/A



11. PEAK POWER SPECTRAL DENSITY

11.1 LIMIT

1. According to §15.247(e) & RSS-210 §A8.2, for digitally modulated systems, the power spectral density conducted from the intentional radiator to the antenna shall not be greater than 8 dBm in any 3 kHz band during any time interval of continuous transmission.
2. According to §15.247(f) & RSS-210 §A8.3, the digital modulation operation of the hybrid system, with the frequency hopping turned off, shall comply with the power density requirements of paragraph (d) of this section.

Test Configuration

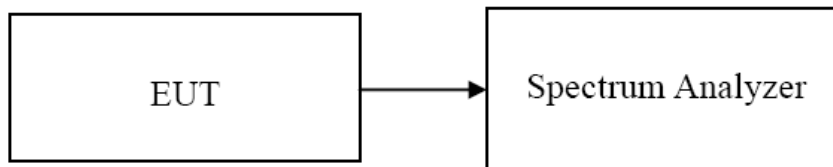

11.2 TEST PROCEDURE

The transmitter output is connected to a spectrum analyzer. Set the RBW = 100 kHz, VBW 300 kHz, span 5-30% greater than EBW, Detector = peak, Trace mode = max hold, Sweep = auto couple. Scale the observed power level to an equivalent value in 3 kHz by adjusting (reducing) the measured power by a bandwidth correction factor (BWCF) where $BWCF = 10\log(3\text{ kHz}/100\text{ kHz} = -15.2\text{ dB})$. Record the maximum reading. Repeat the above procedure until the measurements for all frequencies are completed.

11.3 TEST RESULTS

TEST DATA:

Channel	Frequency (MHz)	PPSD (dBm)	Limit (dBm)	Result
0	2402	-30.45	8	PASS
39	2440	-30.82		PASS
78	2480	-31.50		PASS



LOW CHANNEL

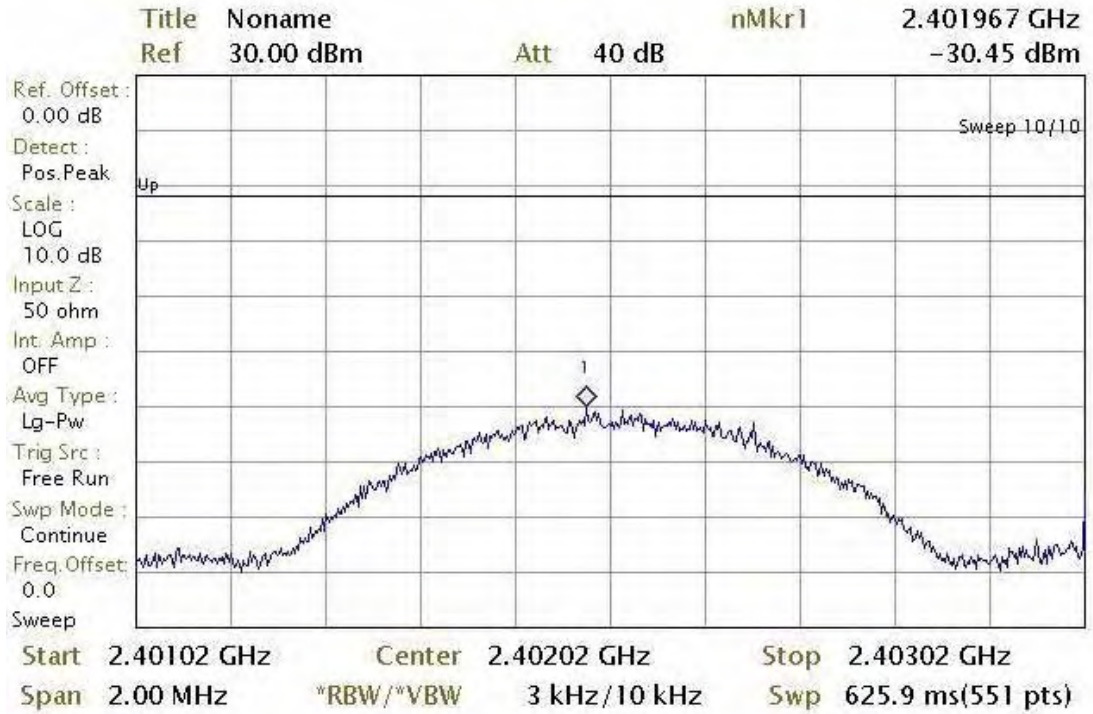

MIDDLE CHENNEL

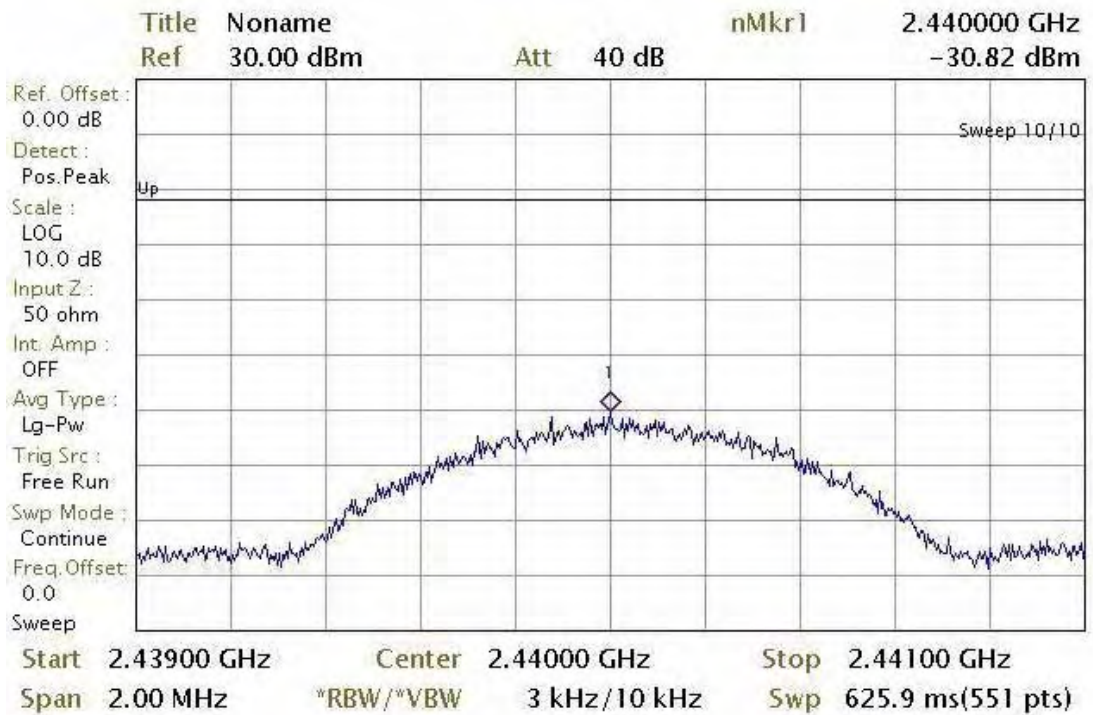



Global Certification Corp.

Appendix 1

Radio frequency Exposure



Radio frequency Exposure

LIMIT

According to §15.247(i), systems operating under the provisions of this section shall be operated in a manner that ensures that the public is not exposed to radio frequency energy levels in excess of the Commission's guidelines. See § 1.1307(b)(1) of this chapter.

According to RSS-Gen §5.5, before equipment certification is granted, the applicable requirements of RSS-102 shall be met.

EUT Specification

EUT	STEELSERIES STRATUS
Frequency band (Operating)	<input type="checkbox"/> WLAN: 2.412GHz ~ 2.462GHz <input type="checkbox"/> WLAN: 5.18GHz ~ 5.32GHz / 5.50GHz ~ 5.70GHz <input type="checkbox"/> WLAN: 5.745GHz ~ 5.825GHz <input checked="" type="checkbox"/> Others: Bluetooth: 2.402GHz ~ 2.480GHz
Device category	<input checked="" type="checkbox"/> Portable (<20cm separation) <input type="checkbox"/> Mobile (>20cm separation) <input type="checkbox"/> Others _____
Exposure classification	<input type="checkbox"/> Occupational/Controlled exposure ($S = 5mW/cm^2$) <input checked="" type="checkbox"/> General Population/Uncontrolled exposure ($S = 1mW/cm^2$)
Antenna diversity	<input checked="" type="checkbox"/> Single antenna <input type="checkbox"/> Multiple antennas <input type="checkbox"/> Tx diversity <input type="checkbox"/> Rx diversity <input type="checkbox"/> Tx/Rx diversity
Max. output power	0.0314 Mw
Antenna gain	-5.45 dBi
Evaluation applied	<input checked="" type="checkbox"/> MPE Evaluation <input type="checkbox"/> SAR Evaluation <input type="checkbox"/> N/A

TEST RESULTS

No non-compliance noted.

(According to KDB 447498 section 4.3.1, the 1-g SAR test exclusion thresholds at test separation distance ≤ 50 mm are determined by:



[(max. power of channel, including tune-up tolerance, mW) / (min. test separation distance, mm)] • [√f(GHz)] ≤ 3.0

The max. average power of channel, including tune-up tolerance(mW) is 0.0349 mW @ 2402MHz (With Tune-up tolerance),

The min. test separation distance (mm) is 5 mm,

So, [(max. power of channel, including tune-up tolerance, mW) / (min. test separation distance, mm)] • [√f(GHz)] = 0.0108 < 3.0 (With Tune-up tolerance).

Therefore, standalone SAR measurements are not required for both head and body.)



Global Certification Corp.

Appendix 2

PHOTOS OF TEST CONFIGURATION

1G-6G

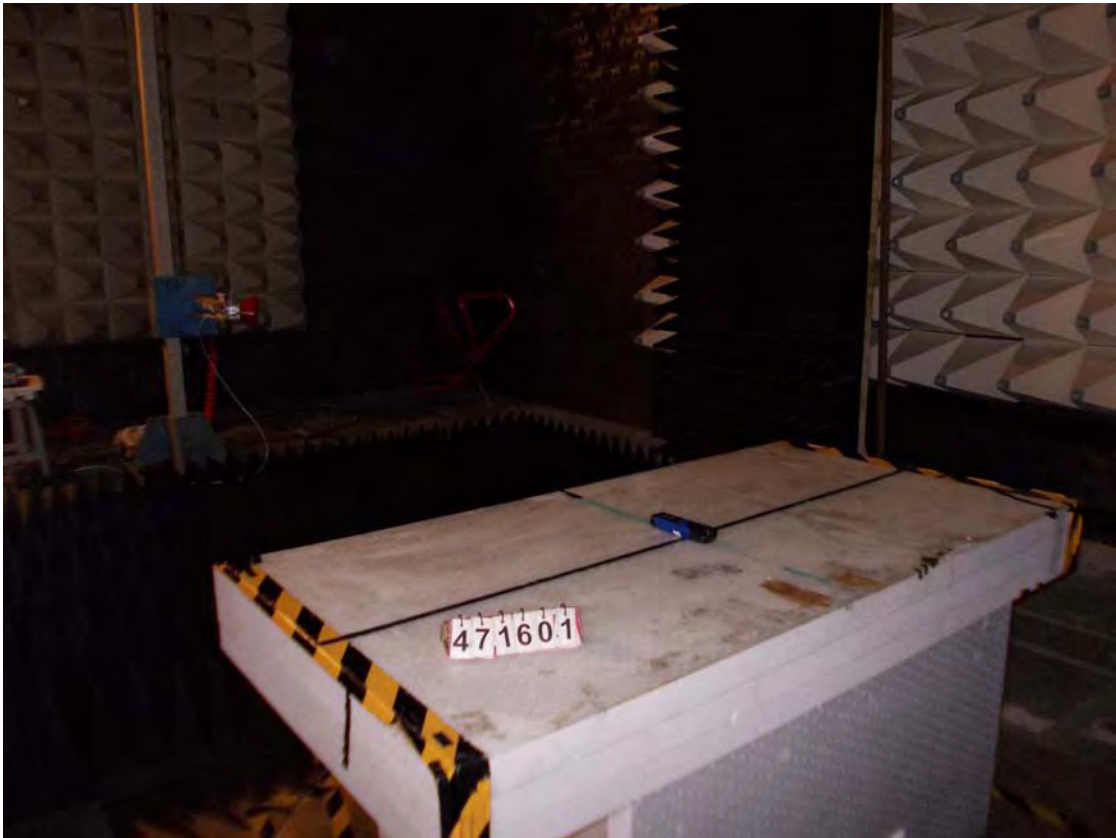

30M-1G

