



TEST REPORT

Report No.: SRTC2019-9003(F)-0050
Product Name: Mobile Phone
Model Name: HLTE220E
Applicant: Hisense International Co., Ltd.
Manufacturer: Hisense Communications Co., Ltd.
Specification: FCC Part15B (Certification)
(2019 edition)
FCC ID: 2ADOBHLTE220E

The State Radio_monitoring_center Testing Center (SRTC)
15th Building, No.30 Shixing Street, Shijingshan District,
Beijing, China

Tel: 86-10-57996183 Fax: 86-10-57996388

CONTENTS

1. General information	3
1.1 Notes of the test report	3
1.2 Information about the testing laboratory.....	3
1.3 Applicant's details	3
1.4 Manufacturer's details.....	3
1.5 Application details	4
1.6 Reference specification.....	4
1.7 Information of EUT	4
1.7.1 General information.....	4
1.7.2EUT details	5
1.7.3 Auxiliary equipment details.....	5
2. Test information	7
2.1 Summary of the test results	7
2.2 Test result.....	8
2.2.1Conducted Emissions-FCC Part15.107	8
2.2.2RadiatedEmissions-FCC Part15.109.....	15
2.3. List of test equipments	26

1. General information

1.1 Notes of the test report

The test report may only be reproduced or published in full. Reproduction or publication of extracts from the report requires the prior written permission of The State Radio_monitoring_center Testing Center (SRTC).

The test results relate only to individual items of the samples which have been tested.

1.2 Information about the testing laboratory

Company: The State Radio_monitoring_center Testing Center (SRTC)
Address: 15th Building, No.30 Shixing Street, Shijingshan District
Testing location: No.80, Zhaojiachang, BeizangCun, Daxing District, Beijing, China.
City: Beijing
Country or Region: China
Contacted person: Liu Jia
Tel: +86 10 57996183
Fax: +86 10 57996388
Email: liujiaf@srtc.org.cn

1.3 Applicant's details

Company: Hisense International Co., Ltd.
Address: Floor 22, Hisense Tower, 17 Donghai Xi Road, Qingdao, 266071, China
City: Qingdao
Country or Region: China
Contacted person: Geng Ruifeng
Tel: +86-532-80877742
Email: gengruifeng@hisense.com

1.4 Manufacturer's details

Company: Hisense Communications Co., Ltd.
Address: No.218 Qianwangang Road, Economic & Technological Development Zone, Qingdao, China
City: Qingdao
Country or Region: China
Contacted person: Song Haibin
Tel: + 86-532-55753700
Email: songhaibin@hisense.com

1.5 Application details

Date of reception of test sample: 15th October. 2019

Date of test: 15th October. 2019 to 30th October. 2019

1.6 Reference specification

FCC Part 15B, 2019 (Certification)

1.7 Information of EUT

1.7.1 General information

Name of EUT	Mobile Phone
Model Name	HLTE220E
FCC ID	2ADOBHLTE220E
Frequency Range	GSM: GSM850 / PCS1900 WCDMA: FDD II / FDD IV / FDD V LTE: FDD 2/ FDD 4/ FDD 5/ FDD 7/FDD 12 Bluetooth: 2.4~2.4835GHz WiFi: 2.4~2.4835GHz/5.15-5.35GHz/5.725-5.85GHz
Equipment Class	Class B
Power Supply	Battery or Charger
Rated Power Supply Voltage	3.8V
Extreme Temperature	Lowest: 0°C Highest: +50°C
Extreme Voltage	Minimum: 3.5V Maximum: 4.35V
HW Version	YK680--MB-V0.1
SW Version	Hisense_HLTE220E_MX02_L201.01_20190926

1.7.2EUT details

Product Name	Model Name	IMEI
Mobile Phone	HLTE220E	1#:863501040485065 2#:863501040486337

Note: As the applicant of this model, [Hisense International Co., Ltd.] declares that the product has two the suppliers of CTP/Earphone/Camera/Data cable. Test the main and second supply equipment respectively, and record the results in the test report.

Main Supply: 1#: 863501040485065

Part Name	Model	Supplier(Brand)	Description
Camera	ST-CFKS816-5MFF-V2.0/ ST-CFKS816-30WFF-V2.0/	Union Image	Front CAM
Camera	ST-CFKS816BF-V2.0	Union Image	Rear CAM
CTP	CCF11700-6.0	Jiangxi Holitech Technology Co.,Ltd	/
Data cable	KLKS816AUSB	Dongguan Keling Electronic Technology Co., Ltd.	/
Earphone	KLKS816A	Shenzhen Jinchuangju Electronic Technology Co.,Ltd.	/

Secondary Supply: 2#: 863501040486337

Part Name	Model Name	supplier	Remark
Camera	HTP1157 HTV1155	JIXIHOLITECH TECHNOLGY CO.LTD	Front CAM
Camera	HTV1156	JIXIHOLITECH TECHNOLGY CO.LTD	Rear CAM
CTP	Y152073B2-D-X	Dongguan Yuye Commumication Technology CO.,ted	/
Data cable	A106-0022-S	SHENZHEN KOAR ELECTIC CO.,LTD	/
Earphone	W1G513A06S	Shenzhen Jinchuangju Electronic Technology Co.,Ltd.	/

1.7.3 Auxiliary equipment details

AE (Auxiliary Equipment) 1#: Laptop

Manufacturer	Lenovo
Model Number	e7000
S/N	PF10VBX6
Input Voltage	100V-240V AC

AE (Auxiliary Equipment) 2#: USB Cable1

Manufacturer	SHENZHEN KOAR ELECTIC CO.,LTD
Model Number	A106-0022-S

AE (Auxiliary Equipment) 3#: USB Cable2

Manufacturer	Dongguan Keling Electronic Technology Co., Ltd.
Model Number	KLKS816AUSB

AE (Auxiliary Equipment) 4#: Battery

Type	Li-Ion
Manufacturer	Shenzhen Tianjin New Energy Technology Co.,Ltd
Model Number	KS816
Capacity	3000mAh
Nominal Voltage	3.8V

AE (Auxiliary Equipment) 5#: Charger

Manufacturer	Shenzhen Tianyin Electronics Co., Ltd
Model Number	TPA-97050100UU
S/N	/
Input Voltage	100V-240V AC 300mA
Output Voltage	5.0VDC 1500mA

AE (Auxiliary Equipment) 6#: Headset1

Manufacturer	Shenzhen Jinchuangju Electronic Technology Co.,Ltd.
Model Number	W1G513A06S



AE (Auxiliary Equipment) 7#: Headset2

Manufacturer	Dongguan Keling Electronic Technology Co., Ltd.
Model Number	KLKS816A

2. Test information

2.1 Summary of the test results

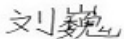
No.	Test case	FCC reference	Verdict
1	Conducted emissions	15.107	Pass
2	Radiated emissions	15.109	Pass

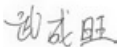
Approved By: LiuWei Director of the test department 	Checked By: GuoYu Vice director of the test department 
Tested By: Mr. Wu Chengwang 	Issued date: <p style="text-align: center;">2019.10.30</p>

2.2 Test result

2.2.1 Conducted Emissions-FCC Part15.107

Ambient condition:

Temperature	Relative humidity	Pressure
19.7°C	40.5%	100.8kPa

Test Setup with laptop:

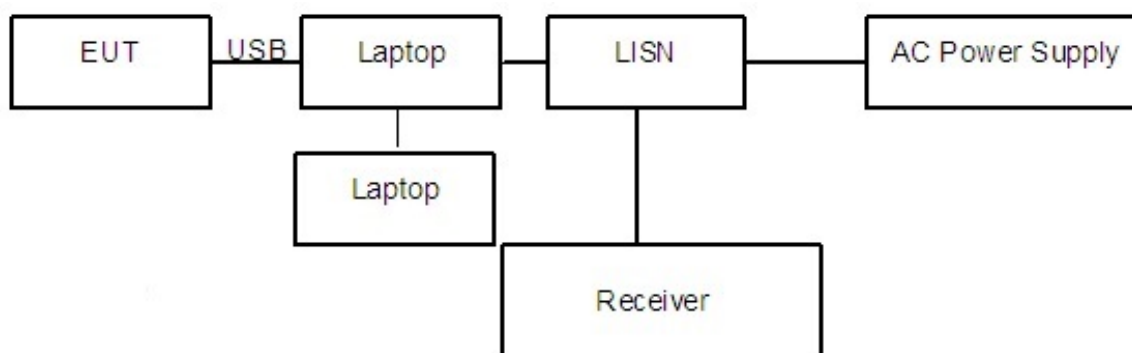

Figure 1

Test Procedure:

The EUT is placed on a non-metallic table 0.8m above the horizontal metal reference ground plane. The accessories of the EUT are connected with the EUT such as headset etc. The EUT was connected with a laptop via the USB cable and transferred the data by copying large files from laptop to the EUT. The laptop's LAN port is connected with another laptop via cable. And the data transferring between two laptops is maintained.

The AC main power supply of the laptop is connected to LISN and LISN is connected to the reference ground. The test set-up and the test methods are performed according to ANSI C63.4:2014.

Then start the test software EMC32. Sweep the whole frequency band through the range from 150 kHz to 30 MHz with RBW 9kHz, VBW 30kHz. The measurement should be done for both L line and N line. During pre-test, the receiver uses both peak detector and average detector. And the final test, the receiver uses both average detector and Quasi-peak detector.

The data of cable loss has been calibrated in full testing frequency range before the testing.

Test Setup with charger:

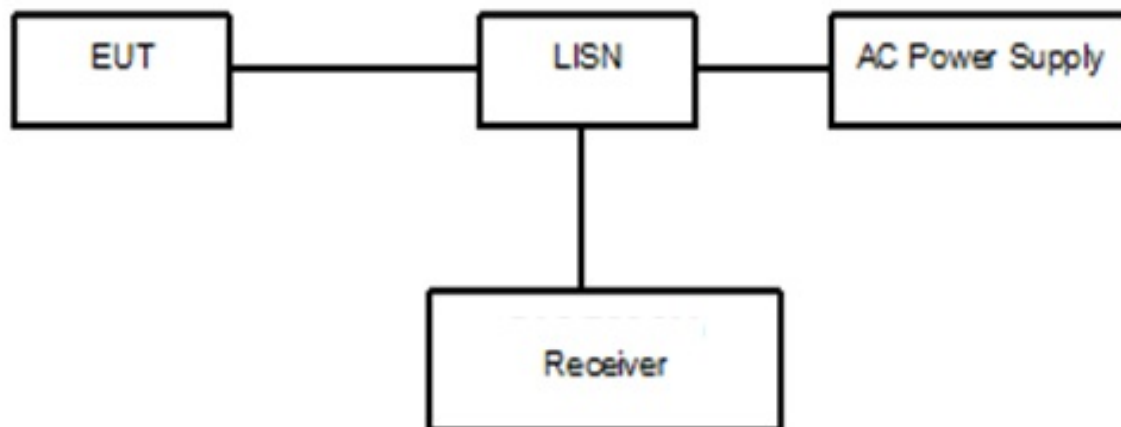

Figure 2

Test Procedure:

The EUT is placed on a non-metallic table 0.8m above the horizontal metal reference ground plane. The EUT is connected with LISN via the charger. The LISN is connected to the reference ground. The accessories of the EUT are connected with the EUT such as headset etc. Open the following functions of EUT: Camera, flash lamp, FM, GPS and video.

The test set-up and the test methods are performed according to ANSI C63.4:2014. Then start the test software EMC32. Sweep the whole frequency band through the range from 150 KHz to 30 MHz with RBW 9kHz, VBW 30kHz. The measurement should be done for both L line and N line. During pre-test, the receiver uses both peak detector and average detector. And the final test, the receiver uses both average detector and Quasi-peak detector.

The data of cable loss has been calibrated in full testing frequency range before the testing.

A "reference path loss" Corr.(dB) is established and the $L_{cable}+ATT+VDF$ is the attenuation of "reference path loss", and including the cable loss, the attenuation of the attenuator, the voltage division factor of AMN.

The measurement results are obtained as described below:

$$P_{result}=P_{mea}+ Corr.(dB)$$

Sample calculation: $(36.04 \text{ dB}\mu\text{V}) = (6.34 \text{ dB}\mu\text{V}) + (29.7 \text{ dB})$, the corresponding frequency is 0.202000MHz.

Limit:

Frequency of Emission(MHz)	Limits(dB μ V)	
	Quasi-peak	Average
0.15~0.5	66 to 56*	56 to 46*
0.5~5	56	46
5~30	60	50

Note: * Decreases with the logarithm of the frequency

Test result:

Noise Level of the Measuring Instrument

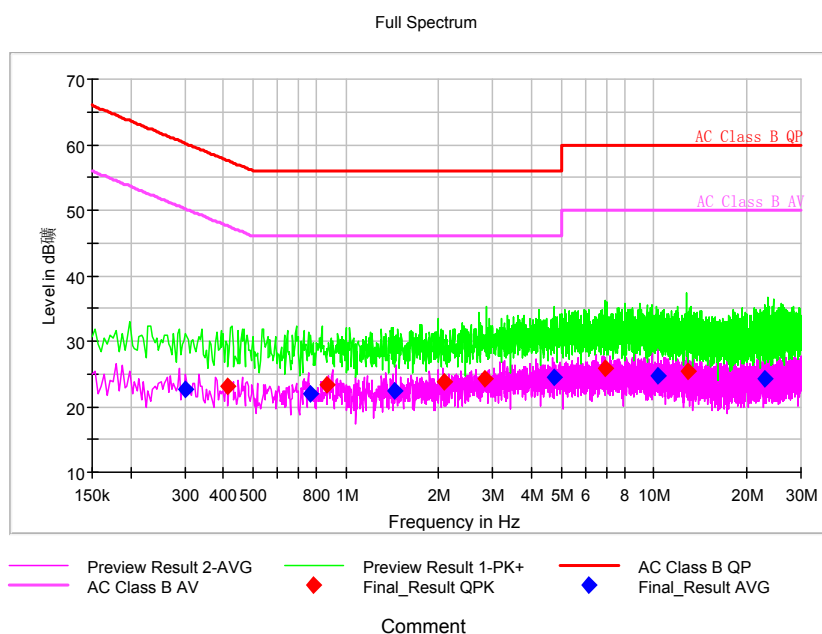

Pic1. Conducted emission L and N Line

1#EUT + 3#USB Cable2+4#Battery+5#Charger+7#Headset2:

Full Spectrum

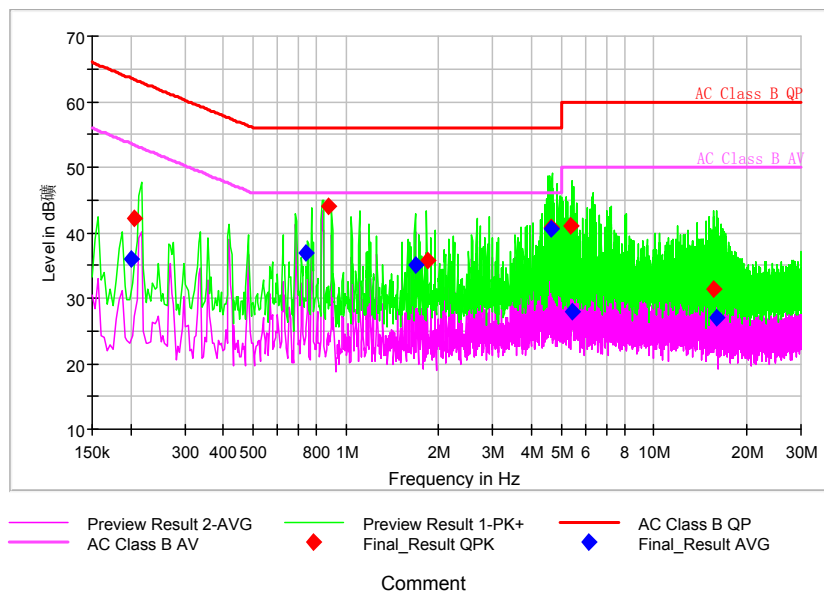

Pic2. Conducted emission L&N Line

Frequency (MHz)	QuasiPeak (dBµV)	Average (dBµV)	Limit (dBµV)	Margin (dB)	Line	Corr. (dB)	Pmea QuasiPeak (dBµV)	Pmea Average (dBµV)
0.202000	---	36.04	53.53	17.48	L1	29.7	---	6.34
0.206000	42.10	---	63.37	21.27	L1	29.7	12.4	---
0.741550	---	36.99	46.00	9.01	L1	29.7	---	7.29
0.877550	44.03	---	56.00	11.97	L1	29.7	14.33	---
1.677081	---	35.06	46.00	10.94	N	29.8	---	5.26
1.838062	35.66	---	56.00	20.34	L1	29.8	5.86	---
4.632381	---	40.49	46.00	5.51	L1	29.8	---	10.69
4.653812	40.86	---	56.00	15.14	N	29.8	11.06	---
5.386450	40.98	---	60.00	19.02	L1	29.8	11.18	---
5.429612	---	27.86	50.00	22.14	L1	29.8	---	-1.94
15.568494	31.27	---	60.00	28.73	L1	29.9	1.37	---
15.966394	---	27.10	50.00	22.90	L1	29.9	---	-2.8

2#EUT + 2#USB Cable1+4#Battery+5#Charger+6#Headset1:

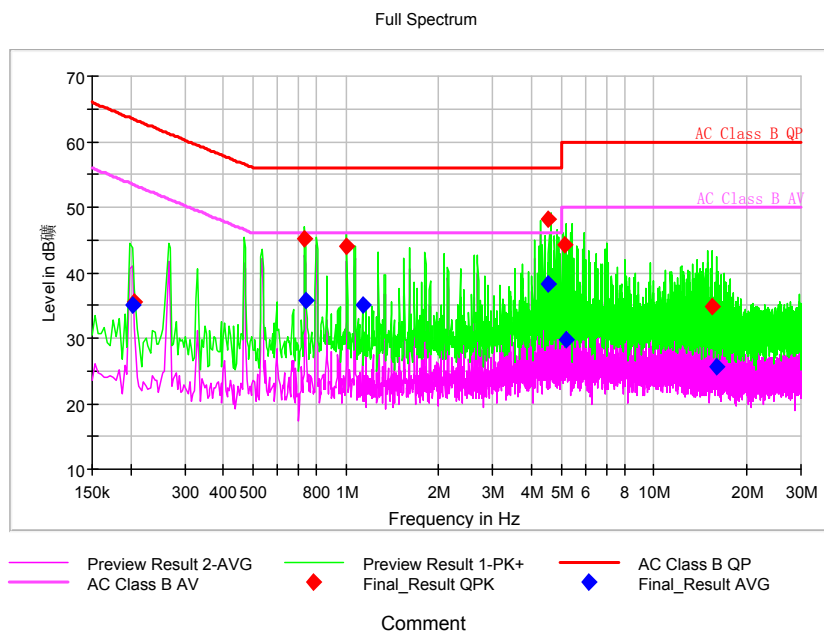

Pic3. Conducted emission L&N Line

Frequency (MHz)	QuasiPeak (dBµV)	Average (dBµV)	Limit (dBµV)	Margin (dB)	Line	Corr. (dB)	Pmea QuasiPeak (dBµV)	Pmea Average (dBµV)
0.202669	---	34.94	53.50	18.56	L1	29.7	---	5.24
0.206000	35.60	---	63.37	27.76	L1	29.7	5.9	---
0.736806	45.17	---	56.00	10.83	L1	29.7	15.47	---
0.739969	---	35.71	46.00	10.29	L1	29.7	---	6.01
1.005456	44.02	---	56.00	11.98	L1	29.7	14.32	---
1.136619	---	35.14	46.00	10.86	L1	29.7	---	5.44
4.552769	48.18	---	56.00	7.82	L1	29.8	18.38	---
4.552769	---	38.39	46.00	7.61	N	29.8	---	8.59
5.154069	44.23	---	60.00	15.77	N	29.8	14.43	---
5.214069	---	29.79	50.00	20.21	L1	29.8	---	-0.01
15.406469	34.93	---	60.00	25.07	L1	29.9	5.03	---
16.031469	---	25.61	50.00	24.39	L1	29.9	---	-4.29

1#EUT + 3#USB Cable2+4#Battery +7#Headset2+Laptop:

Full Spectrum

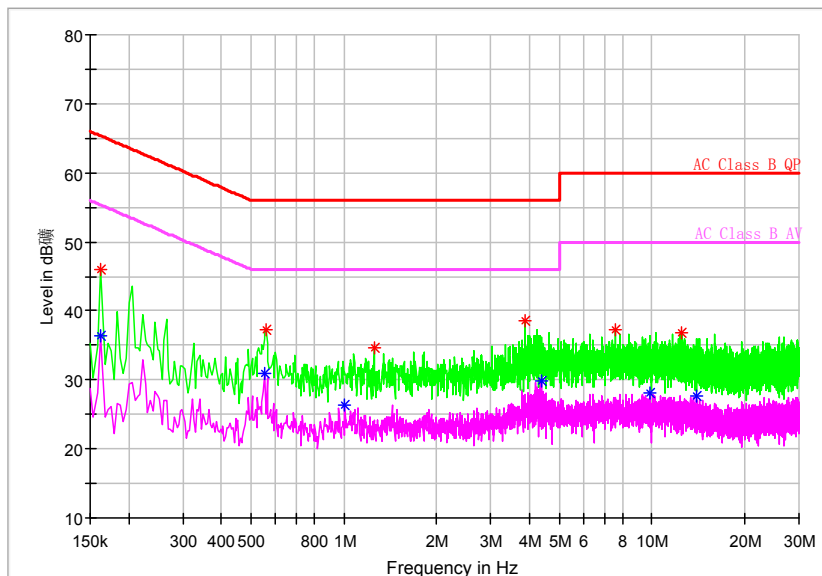

Pic4. Conducted emission L&N Line

Frequency (MHz)	QuasiPeak (dBµV)	Average (dBµV)	Limit (dBµV)	Margin (dB)	Line	Corr. (dB)	Pmea QuasiPeak (dBµV)	Pmea Average (dBµV)
0.162793	46.04	---	65.32	19.28	N	29.7	16.34	---
0.162793	---	36.47	55.32	18.85	N	29.7	---	6.77
0.555107	---	31.03	46.00	14.97	N	29.7	---	1.33
0.559371	37.18	---	56.00	18.82	N	29.7	7.48	---
1.007121	---	26.34	46.00	19.66	N	29.7	---	-3.36
1.254450	34.55	---	56.00	21.45	N	29.7	4.85	---
3.868457	38.53	---	56.00	17.47	N	29.8	8.73	---
4.392964	---	29.79	46.00	16.21	N	29.8	---	-0.01
7.569857	37.17	---	60.00	22.83	N	29.9	7.27	---
9.885364	---	28.07	50.00	21.93	N	29.9	---	-1.83
12.414086	36.84	---	60.00	23.16	N	29.9	6.94	---
14.025986	---	27.61	50.00	22.39	N	29.9	---	-2.29

2#EUT + 2#USB Cable1+4#Battery +6#Headset1+Laptop:

Full Spectrum

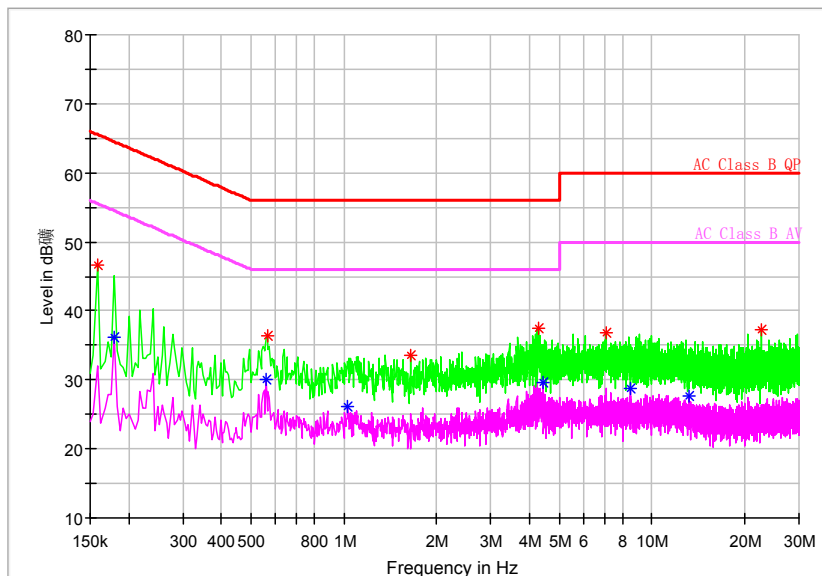

Pic5. Conducted emission L&N Line

Frequency (MHz)	QuasiPeak (dBµV)	Average (dBµV)	Limit (dBµV)	Margin (dB)	Line	Corr. (dB)	Pmea QuasiPeak (dBµV)	Pmea Average (dBµV)
0.158529	46.69	---	65.54	18.85	N	29.7	16.99	---
0.179850	---	36.16	54.49	18.34	N	29.7	---	6.46
0.559371	---	30.09	46.00	15.91	N	29.7	---	0.39
0.563636	36.28	---	56.00	19.72	N	29.7	6.58	---
1.028443	---	26.12	46.00	19.88	N	29.7	---	-3.58
1.642500	33.60	---	56.00	22.40	N	29.8	3.8	---
4.269300	37.42	---	56.00	18.58	N	29.8	7.62	---
4.431343	---	29.61	46.00	16.39	N	29.8	---	-0.19
7.096521	36.77	---	60.00	23.23	N	29.9	6.87	---
8.512264	---	28.86	50.00	21.14	N	29.9	---	-1.04
13.232829	---	27.66	50.00	22.34	N	29.9	---	-2.24
22.563086	37.25	---	60.00	22.75	N	30.0	7.25	---

2.2.2 Radiated Emissions-FCC Part15.109

Ambient condition:

Temperature	Relative humidity	Pressure
19.9°C	40.8%	100.8kPa

Test Setup:

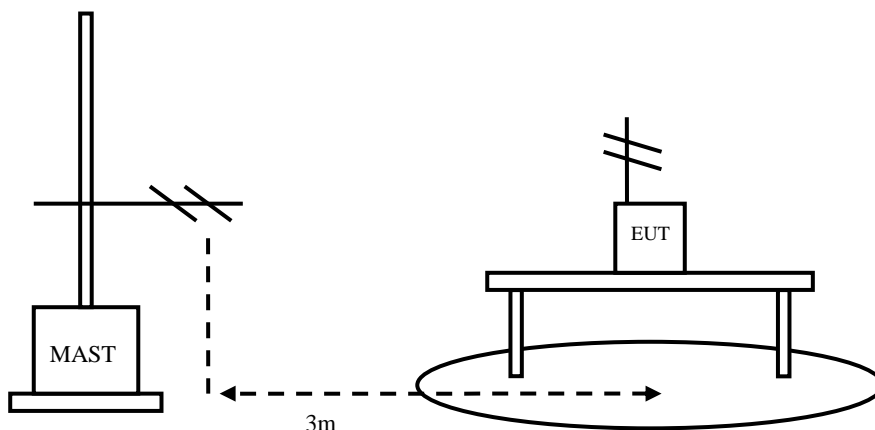

Figure 3

Test Procedure:

EUT+Laptop:

The EUT should be placed on a non-metallic table 80cm above the ground plane. The receive antennas shall be moved from 1 to 4 meters. The distance between EUT and receive antenna should be 3 meters.

The accessories of the EUT are connected with the EUT such as headset etc. The EUT was connected with a laptop via the USB cable and transferred the data by copying large files from laptop to the EUT. The test set-up and the test methods are performed according to ANSI C63.4:2014

Then start the test software EMC32. Sweep the whole frequency band through the range from 30MHz to 1GHz, using receive log period antenna VULB 9163.

During the test, the height of receive antenna shall be moved from 1 to 4 meters, and the antenna shall be performed under horizontal and vertical polarization. The turn table shall be rotated from 0 to 360 degrees for detecting the maximum of radiated spurious signal level. The measurements shall be repeated with orthogonal polarization of the test antenna. The EUT is laid in two modes as follow:
1. put the EUT in horizontal direction; 2. put the EUT in vertical direction.

The data of cable loss and antenna factor have been calibrated in full testing frequency range before the testing.

EUT+Charger:

The EUT should be placed on a non-metallic table 80cm above the ground plane. The receive antennas shall be moved from 1 to 4 meters. The distance between EUT and receive antenna should be 3 meters.

The EUT should work in idle mode. The accessories of the EUT are connected with the EUT such as headset etc. Open the following functions of EUT: Camera, flash lamp, FM, GPS and video. The test set-up and the test methods are performed according to ANSI C63.4:2014.

Then start the test software EMC32. Sweep the whole frequency band through the range from 30MHz to 1GHz, using receive log period antenna VULB 9163.

During the test, the height of receive antenna shall be moved from 1 to 4 meters, and the antenna shall be performed under horizontal and vertical polarization. The turn table shall be rotated from 0 to 360 degrees for detecting the maximum of radiated spurious signal level. The measurements shall be repeated with orthogonal polarization of the test antenna. The EUT is laid in two modes as follow:
1. put the EUT in horizontal direction; 2. put the EUT in vertical direction.

The data of cable loss and antenna factor have been calibrated in full testing frequency range before the testing. All test results are performed with max hold at the horizontal and vertical polarity.

RBW=120kHz, VBW=300kHz, when the test frequency: 30MHz<f<1GHz

RBW=1MHz, VBW=3MHz, when the test frequency: f>1GHz

A “reference path loss” is established and the A_{Rpl} is the attenuation of “reference path loss”, and including the gain of receive antenna, the gain of the preamplifier, the cable loss.

The measurement results are obtained as described below:

$$\text{Result} = P_{\text{mea}} + A_{Rpl}$$

Limit:

Frequency of Emission(MHz)	Limits	
	Detector	Unit (dB μ V/m)
30~88	Quasi-peak	40
88~216	Quasi-peak	43.5
216~960	Quasi-peak	46
960~1000	Quasi-peak	54
1000~5th harmonic of the highest frequency or 40GHz, whichever is lower	Average	54
	Peak	74

Test result:

Sample calculation: $(25.17 \text{ dB } \mu \text{ V/m}) = (46.37 \text{ dB } \mu \text{ V/m}) + (-21.2 \text{ dB})$, the corresponding frequency is 30.000000MHz.

1#EUT + 3#USB Cable2+4#Battery +7#Headset2+Laptop:

Frequency(MHz)	Result(dB μ V/m)	Limit (dB μ V/m)	ARpl (dB)	Pmea (dB μ V/m)	Polarity
30.000000	25.17	40.00	-21.2	46.37	V
72.054650	26.24	40.00	-22.1	48.34	V
168.132400	27.10	43.50	-20.8	47.9	V
407.467300	30.50	46.00	-11.5	42.00	V
455.897900	31.76	46.00	-10.4	42.16	V
743.877400	29.97	46.00	-4.5	34.47	V

2#EUT + 2#USB Cable1+4#Battery +6#Headset1+Laptop:

Frequency(MHz)	Result(dB μ V/m)	Limit (dB μ V/m)	ARpl (dB)	Pmea (dB μ V/m)	Polarity
312.007083	31.81	46.00	-17.7	49.51	V
360.002083	35.17	46.00	-16.3	51.47	V
455.991667	23.56	46.00	-13.4	36.96	V
552.001667	25.93	46.00	-11.0	36.93	V
599.996250	26.22	46.00	-10.2	36.42	V
647.991250	24.44	46.00	-9.3	33.74	V

1#EUT + 3#USB Cable2+4#Battery +5#Charger+7#Headset2:

Frequency(MHz)	Result(dB μ V/m)	Limit (dB μ V/m)	ARpl (dB)	Pmea (dB μ V/m)	Polarity
31.164000	29.44	40.00	-27.0	56.44	V
41.058000	35.70	40.00	-23.8	59.5	V
60.118500	29.98	40.00	-24.2	54.18	V
60.361000	28.40	40.00	-24.3	52.7	V
84.562500	28.40	40.00	-28.6	57	V
87.230000	28.59	40.00	-27.6	56.19	V

2#EUT + 2#USB Cable1+4#Battery +5#Charger +6#Headset1:

Frequency(MHz)	Result(dB μ V/m)	Limit (dB μ V/m)	ARpl (dB)	Pmea (dB μ V/m)	Polarity
40.912500	35.60	40.00	-23.9	59.5	V
60.118500	30.01	40.00	-24.2	54.21	V
60.361000	28.27	40.00	-24.3	52.57	V
60.700500	28.45	40.00	-24.4	52.85	V
85.387000	28.83	40.00	-28.3	57.13	V
86.745000	29.21	40.00	-27.8	57.01	V

1#EUT + 3#USB Cable2+4#Battery +7#Headset2+Laptop: refer to Pic6, Pic7, Pic8, Pic9

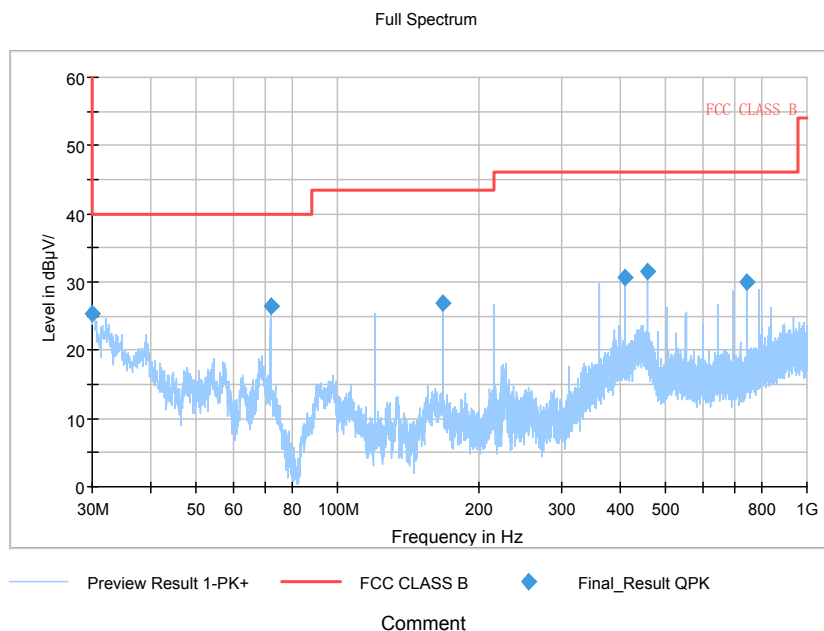

Pic6. Radiated emission(30MHz – 1GHz)

Note : The test data in the graph includes two polarizations: horizontal and vertical

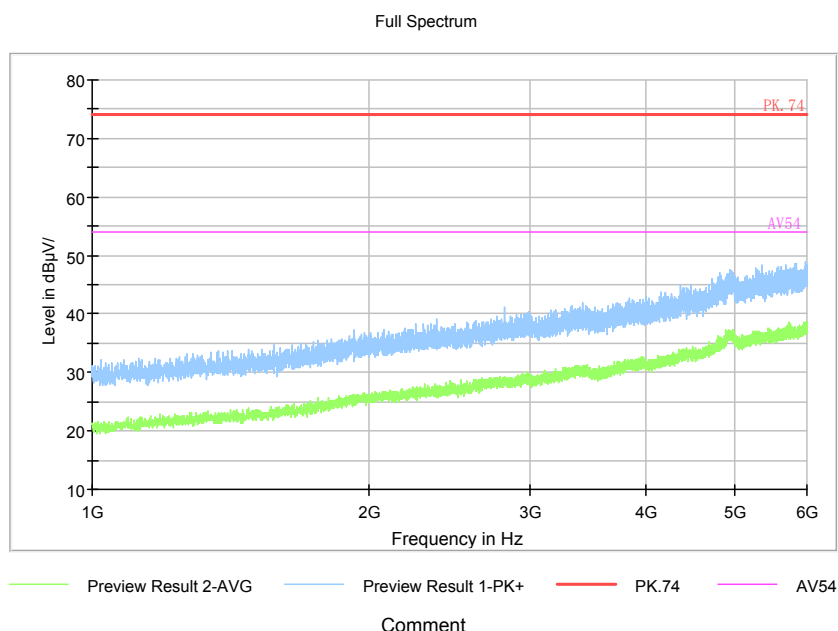

Pic7. Radiated emission (1GHz –6GHz)

Note : The test data in the graph includes two polarizations: horizontal and vertical.

Full Spectrum

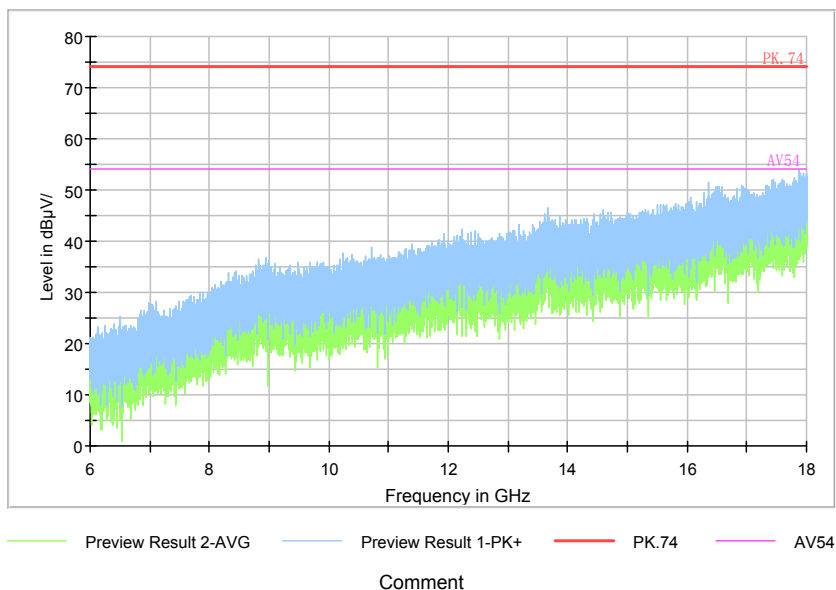

Comment

Pic8. Radiated emission (6GHz –18GHz)

Note : The test data in the graph includes two polarizations: horizontal and vertical.

Full Spectrum

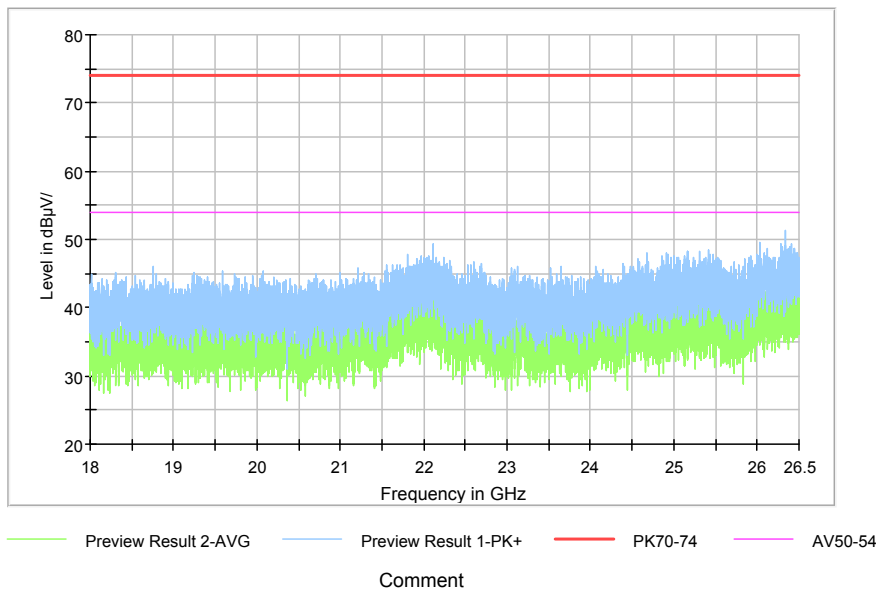

Comment

Pic9. Radiated emission (18GHz –26.5GHz)

Note : The test data in the graph includes two polarizations: horizontal and vertical.

2#EUT + 2#USB Cable1+4#Battery +6#Headset1+Laptop: refer to Pic10, Pic11, Pic12, Pic13

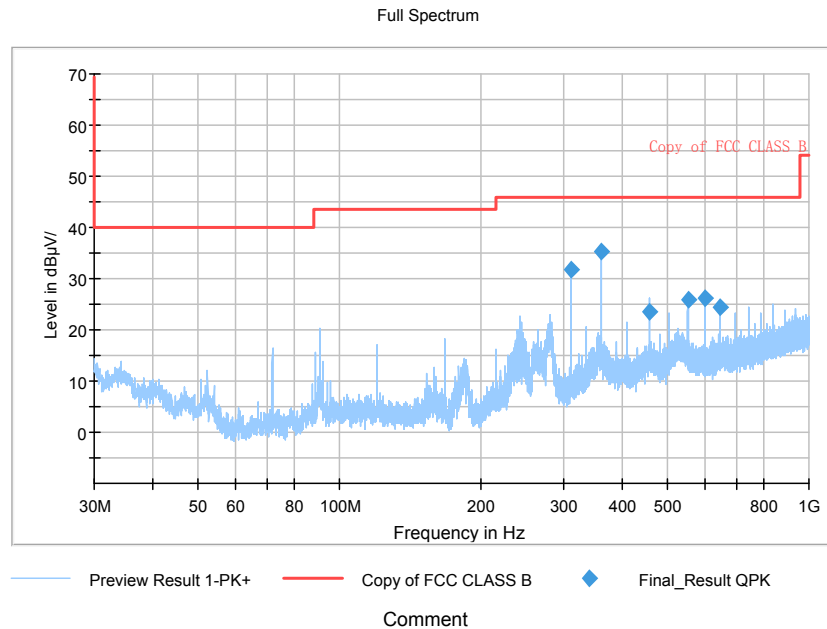

Pic10. Radiated emission(30MHz – 1GHz)

Note : The test data in the graph includes two polarizations: horizontal and vertical

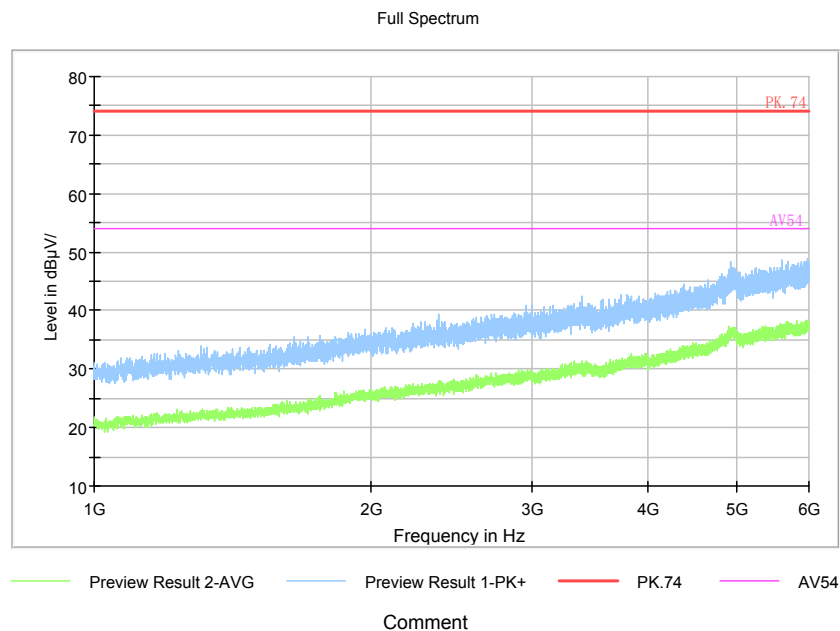

Pic11. Radiated emission (1GHz –6GHz)

Note : The test data in the graph includes two polarizations: horizontal and vertical.

Full Spectrum

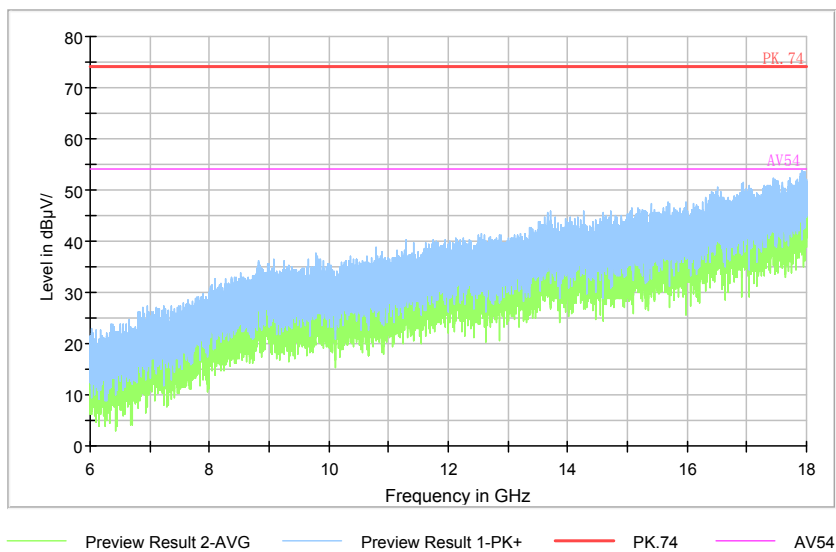

Comment

Pic12. Radiated emission (6GHz –18GHz)

Note : The test data in the graph includes two polarizations: horizontal and vertical.

Full Spectrum

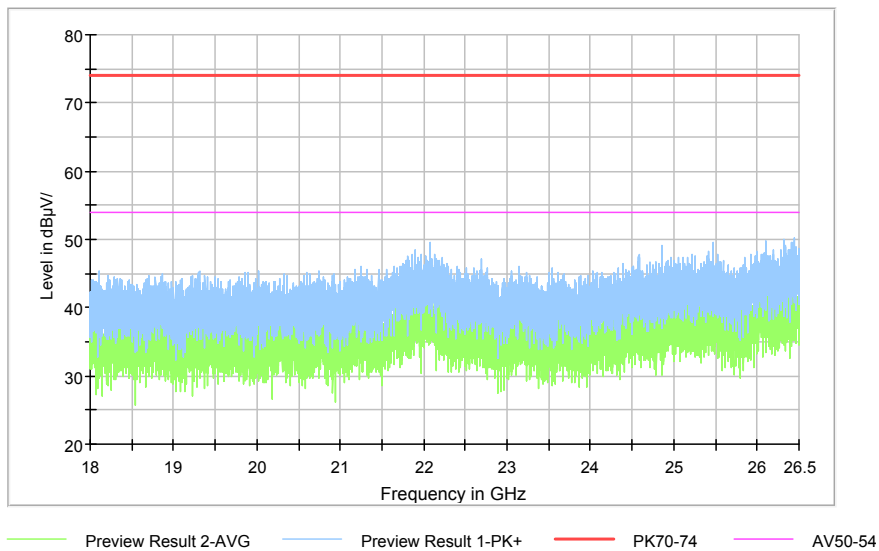

Comment

Pic13. Radiated emission (18GHz –26.5GHz)

Note : The test data in the graph includes two polarizations: horizontal and vertical.

1#EUT + 3#USB Cable2+4#Battery +5#Charger+7#Headset2: refer to Pic14, Pic15, Pic16, Pic17

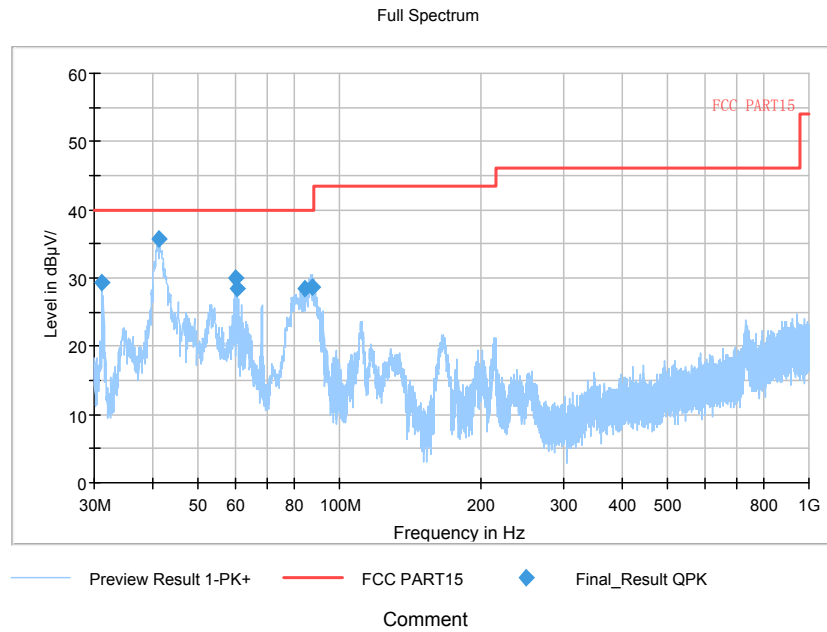

Pic14. Radiated emission(30MHz – 1GHz)

Note : The test data in the graph includes two polarizations: horizontal and vertical

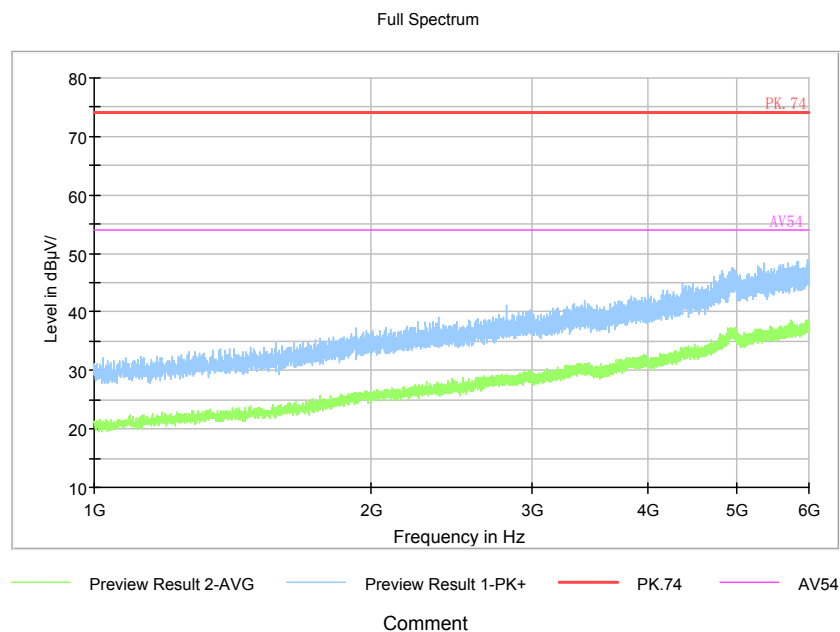

Pic15. Radiated emission (1GHz –6GHz)

Note : The test data in the graph includes two polarizations: horizontal and vertical.

Full Spectrum

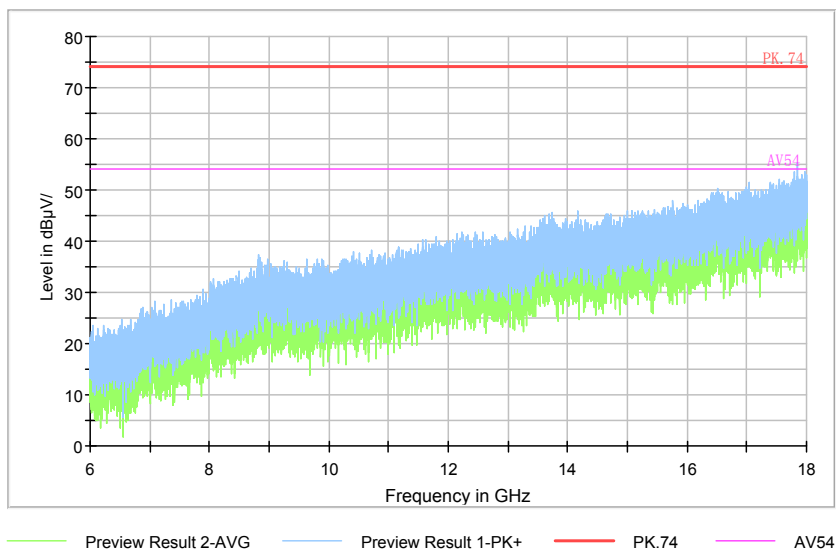

Comment

Pic16. Radiated emission (6GHz –18GHz)

Note : The test data in the graph includes two polarizations: horizontal and vertical.

Full Spectrum

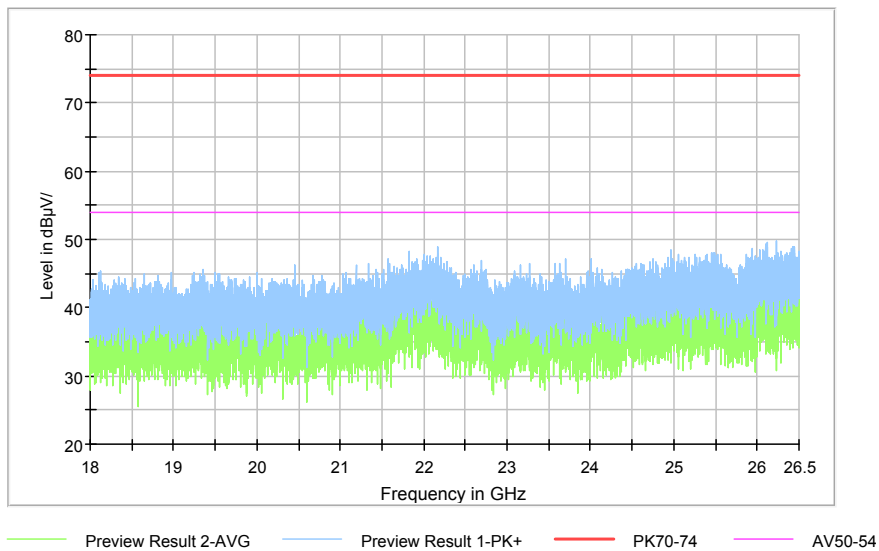

Comment

Pic17. Radiated emission (18GHz –26.5GHz)

Note : The test data in the graph includes two polarizations: horizontal and vertical.

2#EUT + 2#USB Cable1+4#Battery +5#Charger+6#Headset1: refer to Pic18, Pic19, Pic20, Pic21

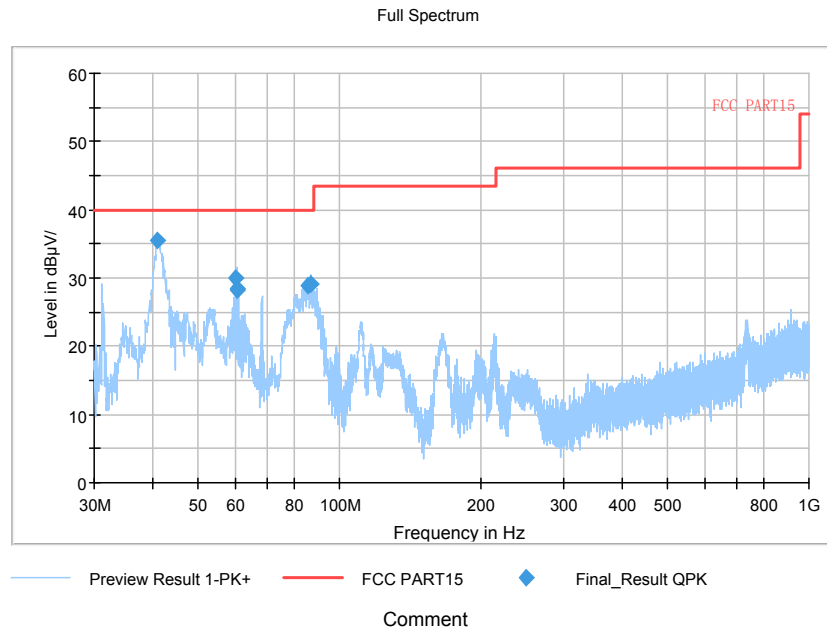

Pic18. Radiated emission(30MHz – 1GHz)

Note : The test data in the graph includes two polarizations: horizontal and vertical

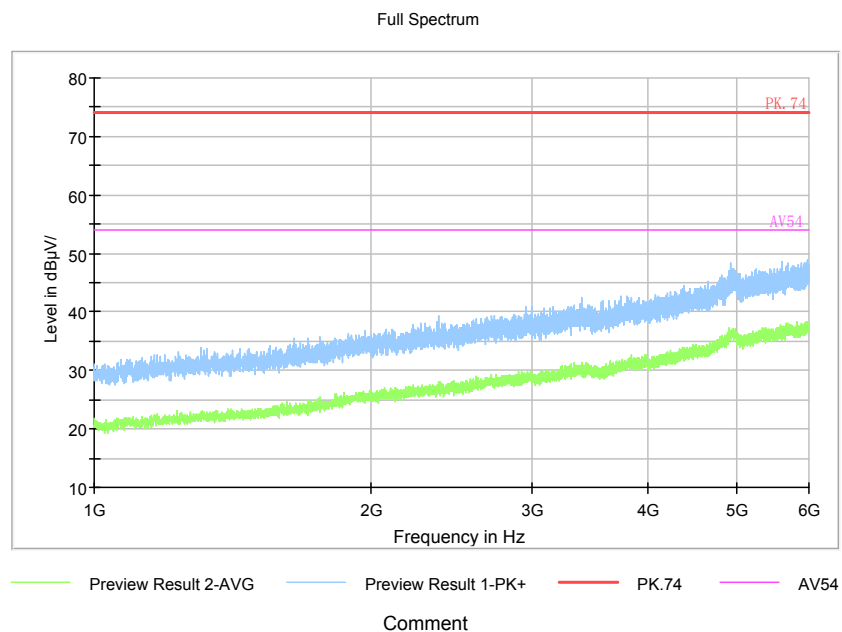

Pic19. Radiated emission (1GHz –6GHz)

Note : The test data in the graph includes two polarizations: horizontal and vertical

Full Spectrum

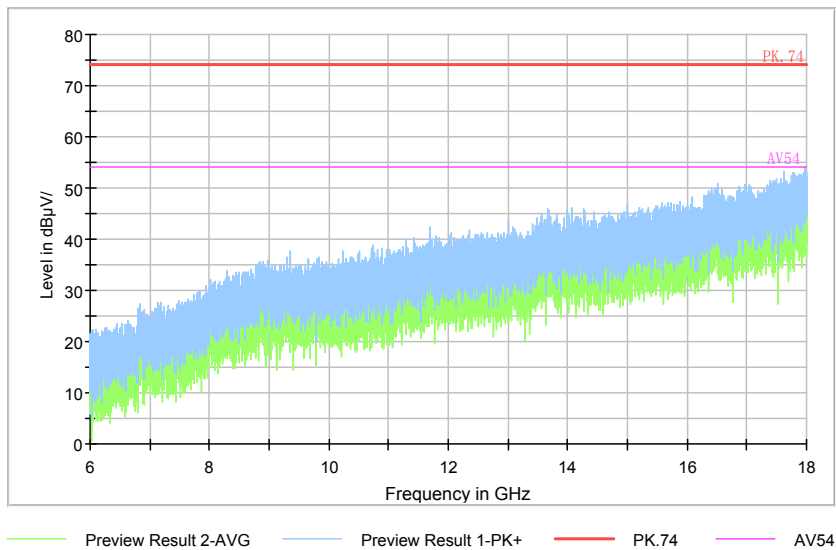

Comment

Pic20. Radiated emission (6GHz –18GHz)

Note : The test data in the graph includes two polarizations: horizontal and vertical

Full Spectrum

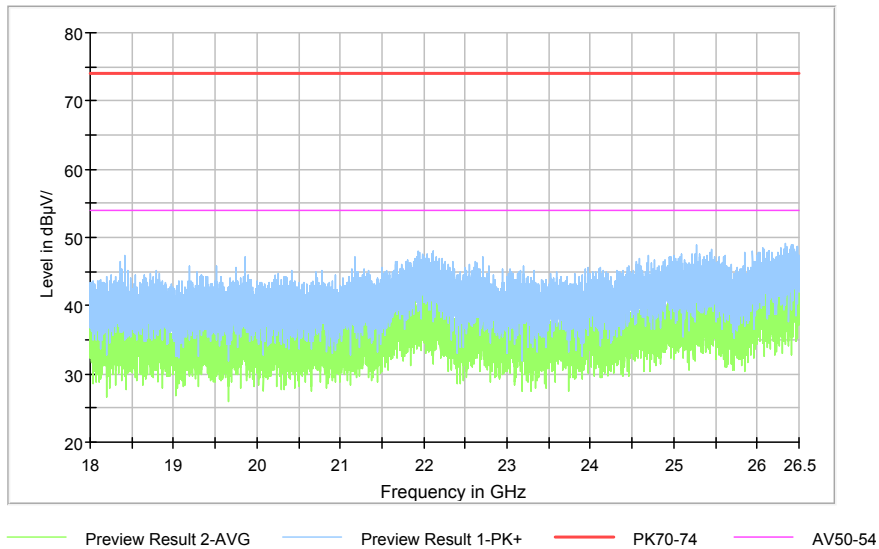

Comment

Pic21. Radiated emission (18GHz –26.5GHz)

Note : The test data in the graph includes two polarizations: horizontal and vertical.

2.3. List of test equipments

No.	Name/Model	Manufacturer	S/N	Calibration Due Date	Calibration Date
1	23.18m×16.88m×9.60mS emi-AnechoicChamber	FRANKONIA	-----	5th Sep. 2021	6th Sep. 2016
2	ESW EMI test receiver	R&S	101574	20th Aug. 2020	20th Aug. 2019
3	9.080m×5.255m×3.525m Shielding room	FRANKONIA	-----	5th Sep. 2021	6th Sep. 2016
4	ESR3 EMI test receiver	R&S	102361	20th Aug. 2020	20th Aug. 2019
5	VULB 9163 Ultra log test antenna	schwarzbeck	867	20th Aug. 2020	20th Aug. 2019
6	ENV216 AMN	R&S	3560.6550. 12	20th Aug. 2020	20th Aug. 2019
7	HF 907 Double-Ridged Waveguide Horn Antenna	R&S	100512	20th Aug. 2020	20th Aug. 2019
8	PS2000 Turn Table	FRANKONIA	-----	-----	-----
9	MA260 Antenna Master	FRANKONIA	-----	-----	-----
10	EMC32EMI test software	R&S	-----	-----	-----