



---

## TEST REPORT FOR RF TESTING

---

Report No.: SRTC2019-9004(F)-19011703(C)

Product Name: Mobile Phone

Product Model: HLTE215E

Applicant: Hisense International Co., Ltd.

Manufacturer: Hisense Communications Co., Ltd.

Specification: FCC CFR47 PART 2, 22, 24, 27 (2019)

FCC ID: 2ADOBHLTE215E

The State Radio\_monitoring\_center Testing Center (SRTC)

15th Building, No.30, Shixing Street, Shijingshan District,

Beijing, P.R.China

Tel: 86-10-57996183 Fax: 86-10-57996388

## CONTENTS

<b>1. GENERAL INFORMATION</b> .....	<b>2</b>
1.1 Notes of the test report .....	2
1.2 Information about the testing laboratory .....	2
1.3 Applicant’s details .....	2
1.4 Manufacturer’s details.....	2
1.5 Test Environment.....	3
<b>2 DESCRIPTION OF THE EQUIPMENT UNDER TEST</b> .....	<b>4</b>
2.1 Final Equipment Build Status .....	4
2.2 Summary table.....	4
2.3 Support Equipment .....	7
2.3 Conducted measurement Path Loss .....	7
<b>3 REFERENCE SPECIFICATION</b> .....	<b>8</b>
<b>4 KEY TO NOTES AND RESULT CODES</b> .....	<b>9</b>
<b>5 RESULT SUMMARY</b> .....	<b>10</b>
<b>6 TEST RESULT</b> .....	<b>11</b>
6.1 RF Power Output .....	11
6.2 Effective Radiated Power.....	12
6.3 Occupied Bandwidth .....	13
6.4 Emission Bandwidth.....	14
6.5 Peak-Average Ratio.....	15
6.6 Spurious Emissions at antenna terminal .....	16
6.7 Band Edges Compliance .....	17
6.8 Frequency Stability .....	18
6.9 Radiated Spurious Emissions .....	19
<b>7 MEASUREMENT UNCERTAINTIES</b> .....	<b>21</b>
<b>8 TEST EQUIPMENTS</b> .....	<b>22</b>
<b>APPENDIX A – TEST DATA OF CONDUCTED EMISSION</b> .....	<b>22</b>
<b>APPENDIX B – TEST DATA OF RADIATED EMISSION</b> .....	<b>236</b>

## 1. GENERAL INFORMATION

### 1.1 Notes of the test report

The test report may only be reproduced or published in full. Reproduction or publication of extracts from the report requires the prior written permission of The State Radio\_monitoring\_center Testing Center (SRTC).

The test results relate only to individual items of the samples which have been tested.

The certification and accreditation identifiers used in this report shall not be applicable to the tested or calibrated samples thereof. The manufacturer shall not mark the tested samples or items (or a separate part of the item) with the identifiers of certification and accreditation to mislead relevant parties about the tested samples or items.

### 1.2 Information about the testing laboratory

Company:	The State Radio_monitoring_center Testing Center (SRTC)
Address:	15th Building, No.30 Shixing Street, Shijingshan District, P.R.China
City:	Beijing
Country or Region:	P.R.China
Contacted person:	Liu Jia
Tel:	+86 10 57996183
Fax:	+86 10 57996388
Email:	liujiarf@srtc.org.cn

### 1.3 Applicant's details

Company:	Hisense International Co., Ltd.
Address:	Floor 22, Hisense Tower, 17 Donghai Xi Road, Qingdao, 266071, China
City:	Qingdao
Country or Region:	China
Contacted person:	Geng Ruifeng
Tel:	+86-532-55753706
Fax:	---
Email:	gengruifeng@hisense.com

### 1.4 Manufacturer's details

Company:	Hisense Communications Co., Ltd.
Address:	218 Qianwangang Road, Qingdao Economic & Technological Development Zone, Qingdao, China
City:	Qingdao
Country or Region:	China
Contacted person:	Zhang chuanzhu
Tel:	+86-532-55756010
Fax:	---
Email:	zhangchuanzhu@hisense.com

## 1.5 Test Environment

Date of Receipt of test sample at SRTC:	2019-01-17
Testing Start Date:	2019-01-17
Testing End Date:	2019-03-12

Environmental Data:	Temperature (°C)	Humidity (%)
Ambient	25	30
Maximum Extreme	35	---
Minimum Extreme	0	---

Normal Supply Voltage (V d.c.):	3.85
Maximum Extreme Supply Voltage (V d.c.):	4.40
Minimum Extreme Supply Voltage (V d.c.):	3.50

## 2 DESCRIPTION OF THE EQUIPMENT UNDER TEST

### 2.1 Final Equipment Build Status

Frequency Range	LTE Band 2: Tx:1850~1910MHz Rx:1930~1990MHz LTE Band 4: Tx:1710~1755MHz Rx:2110~2155MHz LTE Band 5: Tx:824~849 MHz Rx:869 ~894MHz LTE Band 7: Tx:2500~2570MHz Rx:2620~2690MHz LTE Band 12: Tx:699~716 MHz Rx:729~746 MHz LTE Band 66: Tx:1710~1780 MHz Rx:2110~2200 MHz
Modulation Type	QPSK/16QAM/64QAM
Duplex Mode	FDD
Antenna Type	PIFA Antenna
Antenna Information	Main Ant(Down-Ant) support LTE B2/4/5/7/12/66 DIV Ant(Up-Ant) support LTE B4/5/12/66
Power Supply	Battery/Charger
HW Version	V1.00
SW Version	L1592.6.01.05.MX05
IMEI	002101541913327

### 2.2 Summary table

FCC Rule Part	Frequency Range(MHz)	EIRP/ERP (W)	Frequency Tolerance (ppm)	Emission Designator	Emission Bandwidth (MHz)	Measured 26dBC Bandwidth (MHz)	Communication Type
LTE BAND2							
24E	1850.7-1909.3	0.043	0.019	1M10G7D	1.4M	1.290	QPSK
	1850.7-1909.3	0.030	0.019	1M10D7W	1.4M	1.313	16QAM
	1850.7-1909.3	0.030	0.019	1M10W7D	1.4M	1.321	64QAM
	1851.5-1908.5	0.041	0.017	2M73G7D	3M	3.067	QPSK
	1851.5-1908.5	0.031	0.017	2M73D7W	3M	3.066	16QAM
	1851.5-1908.5	0.031	0.017	2M73W7D	3M	3.054	64QAM
	1852.5-1907.5	0.041	0.018	4M50G7D	5M	5.072	QPSK
	1852.5-1907.5	0.028	0.018	4M50D7W	5M	5.011	16QAM
	1852.5-1907.5	0.029	0.018	4M50W7D	5M	4.990	64QAM
	1855-1905	0.041	0.019	9M07G7D	10M	10.060	QPSK
	1855-1905	0.029	0.019	9M02D7W	10M	9.965	16QAM
	1855-1905	0.028	0.019	9M02W7D	10M	9.965	64QAM
	1857.5-1902.5	0.041	0.020	13M4G7D	15M	14.730	QPSK
	1857.5-1902.5	0.030	0.020	13M4D7W	15M	14.680	16QAM
	1857.5-1902.5	0.028	0.020	13M4W7D	15M	14.650	64QAM
	1860-1900	0.043	0.018	17M8G7D	20M	19.240	QPSK
	1860-1900	0.035	0.018	17M8D7W	20M	19.250	16QAM
1860-1900	0.032	0.018	17M9W7D	20M	19.190	64QAM	

LTE BAND4							
27L	1710.7-1754.3	0.036	0.020	1M10G7D	1.4M	1.285	QPSK
	1710.7-1754.3	0.027	0.020	1M10D7W	1.4M	1.306	16QAM
	1710.7-1754.3	0.027	0.020	1M10W7D	1.4M	1.307	64QAM
	1711.5-1753.5	0.036	0.019	2M74G7D	3M	3.073	QPSK
	1711.5-1753.5	0.027	0.019	2M73D7W	3M	3.050	16QAM
	1711.5-1753.5	0.028	0.019	2M74W7D	3M	3.062	64QAM
	1712.5-1752.5	0.035	0.017	4M50G7D	5M	5.036	QPSK
	1712.5-1752.5	0.026	0.017	4M50D7W	5M	5.028	16QAM
	1712.5-1752.5	0.026	0.017	4M50W7D	5M	4.975	64QAM
	1715-1750	0.039	0.018	9M07G7D	10M	10.010	QPSK
	1715-1750	0.026	0.018	9M01D7W	10M	9.968	16QAM
	1715-1750	0.026	0.018	9M03W7D	10M	10.020	64QAM
	1717.5-1747.5	0.037	0.020	13M5G7D	15M	14.660	QPSK
	1717.5-1747.5	0.027	0.020	13M5D7W	15M	14.730	16QAM
	1717.5-1747.5	0.027	0.020	13M5W7D	15M	14.690	64QAM
	1720-1745	0.039	0.011	17M9G7D	20M	19.350	QPSK
1720-1745	0.029	0.011	17M9D7W	20M	19.390	16QAM	
1720-1745	0.028	0.011	17M9W7D	20M	19.270	64QAM	
LTE BAND5							
22H	824.7-848.3	0.038	0.018	1M10G7D	1.4M	1.304	QPSK
	824.7-848.3	0.030	0.018	1M10D7W	1.4M	1.299	16QAM
	824.7-848.3	0.031	0.018	1M10W7D	1.4M	1.307	64QAM
	825.5-847.5	0.039	0.020	2M74G7D	3M	3.079	QPSK
	825.5-847.5	0.028	0.020	2M74D7W	3M	3.084	16QAM
	825.5-847.5	0.029	0.020	2M74W7D	3M	3.077	64QAM
	826.5-846.5	0.040	0.019	4M51G7D	5M	5.068	QPSK
	826.5-846.5	0.028	0.019	4M52D7W	5M	5.009	16QAM
	826.5-846.5	0.028	0.019	4M51W7D	5M	5.017	64QAM
	829-844	0.040	0.019	9M09G7D	10M	10.050	QPSK
	829-844	0.031	0.019	9M02D7W	10M	10.040	16QAM
	829-844	0.030	0.019	9M07W7D	10M	10.100	64QAM
LTE BAND7							
27M	2502.5-2567.5	0.066	0.016	4M51G7D	5M	5.053	QPSK
	2502.5-2567.5	0.047	0.016	4M51D7W	5M	5.028	16QAM
	2502.5-2567.5	0.047	0.016	4M51W7D	5M	5.058	64QAM
	2505-2565	0.066	0.020	9M08G7D	10M	10.070	QPSK
	2505-2565	0.048	0.020	9M02D7W	10M	9.988	16QAM
	2505-2565	0.049	0.020	9M05W7D	10M	10.000	64QAM
	2507.5-2562.5	0.068	0.019	13M5G7D	15M	14.760	QPSK
	2507.5-2562.5	0.049	0.019	13M5D7W	15M	14.710	16QAM
	2507.5-2562.5	0.050	0.019	13M5W7D	15M	14.710	64QAM
	2510-2560	0.069	0.017	17M9G7D	20M	19.370	QPSK
	2510-2560	0.051	0.017	17M9D7W	20M	19.370	16QAM
	2510-2560	0.051	0.017	17M9W7D	20M	19.340	64QAM

LTE BAND12							
27H	699.7-715.3	0.045	0.020	1M10G7D	1.4M	1.311	QPSK
	699.7-715.3	0.040	0.020	1M10D7W	1.4M	1.301	16QAM
	699.7-715.3	0.041	0.020	1M10W7D	1.4M	1.313	64QAM
	700.5-714.5	0.046	0.017	2M74G7D	3M	3.065	QPSK
	700.5-714.5	0.041	0.017	2M74D7W	3M	3.083	16QAM
	700.5-714.5	0.042	0.017	2M75W7D	3M	3.069	64QAM
	701.5-713.5	0.046	0.020	4M51G7D	5M	5.059	QPSK
	701.5-713.5	0.041	0.020	4M52D7W	5M	5.029	16QAM
	701.5-713.5	0.042	0.020	4M51W7D	5M	4.973	64QAM
	704-711	0.048	0.019	9M10G7D	10M	10.060	QPSK
	704-711	0.042	0.019	9M03D7W	10M	9.993	16QAM
704-711	0.043	0.019	9M06W7D	10M	10.080	64QAM	
LTE BAND66							
27L	1710.7-1779.3	0.034	0.020	1M10G7D	1.4M	1.302	QPSK
	1710.7-1779.3	0.026	0.020	1M10D7W	1.4M	1.302	16QAM
	1710.7-1779.3	0.026	0.020	1M10W7D	1.4M	1.311	64QAM
	1711.5-1778.5	0.035	0.020	2M69G7D	3M	2.952	QPSK
	1711.5-1778.5	0.026	0.020	2M70D7W	3M	2.934	16QAM
	1711.5-1778.5	0.026	0.020	2M69W7D	3M	2.932	64QAM
	1712.5-1777.5	0.035	0.017	4M52G7D	5M	5.036	QPSK
	1712.5-1777.5	0.026	0.017	4M52D7W	5M	5.027	16QAM
	1712.5-1777.5	0.026	0.017	4M51W7D	5M	4.996	64QAM
	1715-1775	0.037	0.020	9M07G7D	10M	10.040	QPSK
	1715-1775	0.026	0.020	9M02D7W	10M	10.060	16QAM
	1715-1775	0.026	0.020	9M05W7D	10M	10.070	64QAM
	1717.5-1772.5	0.037	0.019	13M5G7D	15M	14.700	QPSK
	1717.5-1772.5	0.026	0.019	13M5D7W	15M	14.640	16QAM
	1717.5-1772.5	0.026	0.019	13M5W7D	15M	14.660	64QAM
	1720-1770	0.038	0.018	17M9G7D	20M	19.270	QPSK
	1720-1770	0.027	0.018	17M9D7W	20M	19.260	16QAM
	1720-1770	0.027	0.018	17M9W7D	20M	19.280	64QAM

## 2.3 Support Equipment

The following support equipment was used to exercise the EUT during testing:

Equipment	Battery
Manufacturer	Huizhou Highpower Technology Co., Ltd.
Model Number	LPN385300A
Serial Number	---
Equipment	Charger
Manufacturer	JIANGSU CHENYANG ELECTRON CO.,LTD
Model Number	CC10-050200U
Serial Number	---
Equipment	Headset
Manufacturer	NEW LEADER INDUSTRY CO.,LTD
Model Number	NLD-EM116T-046S
Serial Number	---
Equipment	USB Cable
Manufacturer	SHENZHEN FKY-QY HARDWARE ELECTRONIC CO.,LTD
Model Number	FKYM1-2428L10WHR-C1
Serial Number	---

## 2.3 Conducted measurement Path Loss

LTE B2 Offset 6.8dB = Power Divider 6dB+ Temporary antenna connector loss 0.2dB+ Cable loss 0.6dB

LTE B4 Offset 6.8dB = Power Divider 6dB+ Temporary antenna connector loss 0.2dB+ Cable loss 0.6dB

LTE B5 Offset 6.5dB = Power Divider 6dB+ Temporary antenna connector loss 0.2dB+ Cable loss 0.3dB

LTE B7 Offset 7.0dB = Power Divider 6dB+ Temporary antenna connector loss 0.2dB+ Cable loss 0.8dB

LTE B12 Offset 6.5dB = Power Divider 6dB+ Temporary antenna connector loss 0.2dB+ Cable loss 0.3dB

LTE B66 Offset 6.8dB = Power Divider 6dB+ Temporary antenna connector loss 0.2dB+ Cable loss 0.6dB



### **3 REFERENCE SPECIFICATION**

The tests documented in this report were performed in accordance with ANSI C63.26:2015, FCC CFR 47 Part 2, FCC KDB 971168 D01 v02r02, KDB 971168 D02 v01, Part 22, Part 24, Part 27.

Specification	Version	Title
ANSI C63.26:2015	11 December 2015	American National Standard for Compliance Testing of Transmitters Used in Licensed Radio Services
FCC CFR 47 Part 2	2019	FREQUENCY ALLOCATIONS AND RADIO TREATY MATTERS; GENERAL RULES AND REGULATIONS
FCC CFR 47 Part 22	2019	PUBLIC MOBILE SERVICES
FCC CFR 47 Part 24	2019	PERSONAL COMMUNICATIONS SERVICES
FCC CFR 47 Part 27	2019	MISCELLANEOUS WIRELESS COMMUNICATIONS SERVICES
KDB 971168 D01	v03r01	MEASUREMENT GUIDANCE FOR CERTIFICATION OF LICENSED DIGITAL TRANSMITTERS
KDB 971168 D02	v02r01	MISCELLANEOUS AND BASIC REVIEW AND APPROVAL ITEMS FOR TRANSMITTING EQUIPMENT USED IN LICENSED RADIO SERVICES
ANSI C63.26	2015	American National Standard for Compliance Testing of Transmitters Used in Licensed Radio Services
KDB 971168 D01	April 9, 2018	MEASUREMENT GUIDANCE FOR CERTIFICATION OF LICENSED DIGITAL TRANSMITTERS

## **4 KEY TO NOTES AND RESULT CODES**



The following are the definition of the test result.

Code	Meaning
PASS	Test result shows that the requirements of the relevant specification have been met.
FAIL	Test result shows that the requirements of the relevant specification have not been met.
N/T	Test case is not tested.
NTNV	Nominal voltage, Normal Temperature
HV	High voltage, Normal Temperature
LV	Low voltage, Normal Temperature
HTHV	high voltage, High Temperature
LTHV	High voltage, Low Temperature
HTLV	Low voltage, High Temperature
LTLV	Low voltage, Low Temperature

## 5 RESULT SUMMARY

The following table summarizes the test results obtained.

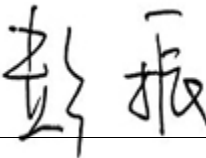
No.	Test case	FCC reference	Verdict
1	RF Power Output	2.1046	Pass
2	Effective Radiated Power and Effective Isotropic Radiated Power	22.913, 24.232, 27.50	Pass
3	Occupied Bandwidth	2.1049	Pass
4	Peak-Average Ratio	22.913, 24.232, 27.50	Pass
5	Emission Bandwidth	2.1049	Pass
6	Spurious Emissions at antenna terminals	2.1051, 22.901, 22.917, 24.238, 27.53	Pass
7	Band Edges Compliance	2.1051, 22.359, 22.917, 24.238, 27.53	Pass
8	Frequency Stability	2.1055, 22.355, 24.235, 27.54	Pass
9	Radiated Spurious Emissions	2.1053, 22.917, 24.238, 27.53	Pass

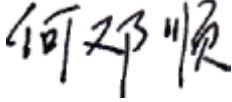
This Test Report Is Issued by: Mr. Peng Zhen 	Checked by: Mr. Li Bin 
Tested by: Mr. He Dengshun 	Issued date:  20190312

## **6 TEST RESULT**

### **6.1 RF Power Output**

Rule Part(s)  
 FCC: 2.1046

Ambient condition:

Temperature	Relative humidity	Pressure
23°C	42%	101.9kPa

Test Setup:

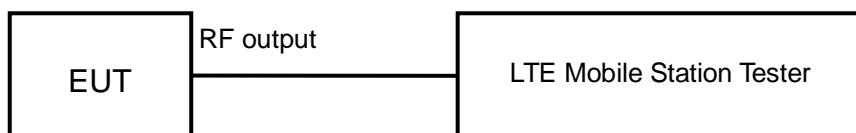

Test procedure:

After a radio link has been established between EUT and Tester, the output power of the cell signal of the testing equipment will be decreased until the output power of the EUT reach a maximum value. Then the test data can be read at the tester screen. The loss between RF output port of the EUT and the input port of the tester will be taken into consideration.

Limits	≤30dBm
--------	--------

Test result:

The test results are shown in Appendix A.

## 6.2 Effective Radiated Power

Rule Part(s)

FCC: 22.913, 24.232, 27.50

Ambient condition:

Temperature	Relative humidity	Pressure
20.8°C	36.5%	100.9kPa

Test setup:

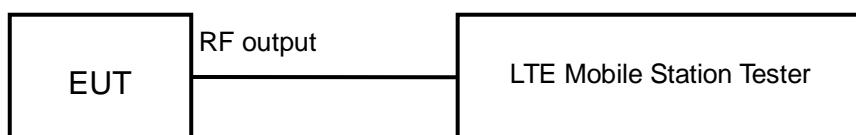

### ERP/EIRP LIMIT

This value is EIRP since the measurement is calibrated using an antenna of known gain (2.15dB) and known input power. ERP can be calculated from EIRP by subtracting the gain of the dipole,  $ERP = EIRP - 2.15 \text{ (dB)}$ .

22.913(a) - The ERP of mobile transmitters and auxiliary test transmitters must not exceed 7Watts.

24.232(c) - Mobile/portable stations are limited to 2 watts e.i.r.p. peak power and the equipment must employ means to limit the power to the minimum necessary for successful communications.

27.50 (c) (10) the following power and antenna height requirements apply to stations transmitting in the 698–746 MHz band, the portable stations (hand-held devices) are limited to 3 watts ERP.

27.50 (b)(10) Portable stations (hand-held devices) transmitting in the 746–757 MHz, 758–763 MHz, 776–793 MHz, and 805–806 MHz bands are limited to 3 watts ERP.

27.50 (d)(4) The following power and antenna height requirements apply to stations transmitting in the 1710–1755 MHz and 2110–2155 MHz bands: Fixed, mobile, and portable (hand-held) stations operating in the 1710–1755 MHz band are limited to 1 watt EIRP

27.50 (h) The following power limits shall apply in the BRS and EBS: (2) Mobile and other user stations. Mobile stations are limited to 2.0 watts EIRP. All user stations are limited to 2.0 watts transmitter output power.

Test result:

The test results are shown in Appendix A.

### 6.3 Occupied Bandwidth

Rule Part(s)  
FCC: 2.1049

Ambient condition:

Temperature	Relative humidity	Pressure
23°C	42%	101.9kPa

Test Setup:

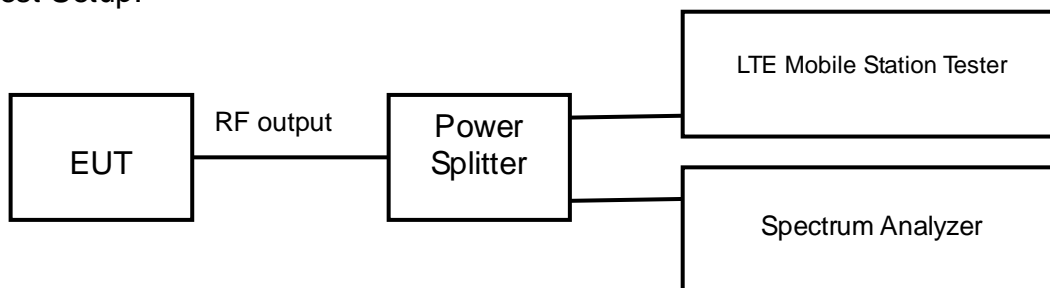

Test procedure:

After a radio link has been established between EUT and Tester, the output power of the cell signal of the testing equipment will be decreased until the output power of the EUT reach a maximum value. The occupied bandwidth is measured using spectrum analyzer. RBW is set to 30kHz on spectrum analyzer. The bandwidth of 99% power can be read on spectrum analyzer.

The measurement will be conducted at three channels (Bottom, middle and top channels of LTE band)

Limits: No specific occupied bandwidth requirements in part 2.1049

Test result:

The test results are shown in Appendix A.

### 6.4 Emission Bandwidth

Rule Part(s)  
 FCC: 2.1049

Ambient condition:

Temperature	Relative humidity	Pressure
23°C	42%	101.9kPa

Test Setup:

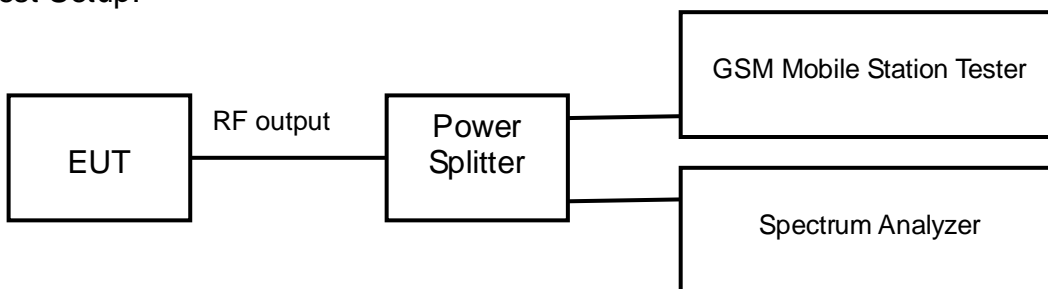

Test procedure:

After a radio link has been established between EUT and Tester, the output power of the cell signal of the testing equipment will be decreased until the output power of the EUT reach a maximum value. The emission bandwidth is measured using spectrum analyzer. RBW is set to 3 kHz on spectrum analyzer. The bandwidth of -26dB transmitter power can be read on spectrum analyzer.

Limits: No specific emission bandwidth requirements in part 22.917(b)

Test result:

The test results are shown in Appendix A.

### 6.5 Peak-Average Ratio

Rule Part(s)  
 FCC: 22.913, 24.232, 27.50

Ambient condition:

Temperature	Relative humidity	Pressure
23°C	42%	101.9kPa

Test Setup:

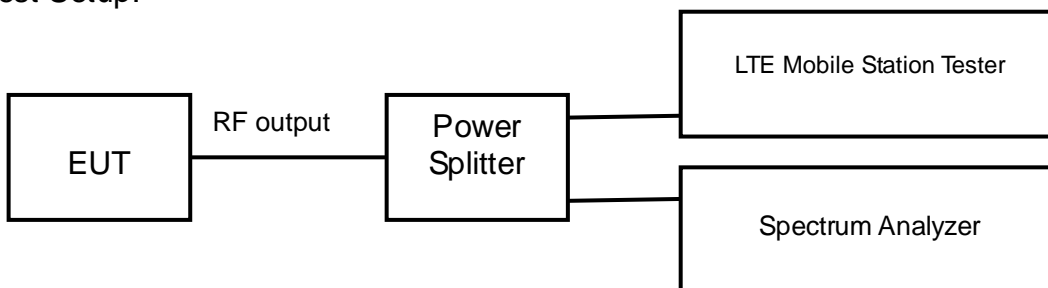

Test procedure:

After a radio link has been established between EUT and Tester, the output power of the cell signal of the testing equipment will be decreased until the output power of the EUT reach a maximum value. The Peak-Average Ratio is measured using spectrum analyzer. RBW is set to 30 kHz on spectrum analyzer. The Peak-Average Ratio can be read on spectrum analyzer.

Limits	≤13dB
--------	-------

Test result:

The test results are shown in Appendix A.



## 6.6 Spurious Emissions at antenna terminal

Ambient condition:

Temperature	Relative humidity	Pressure
23°C	42%	101.9kPa

Test Setup:

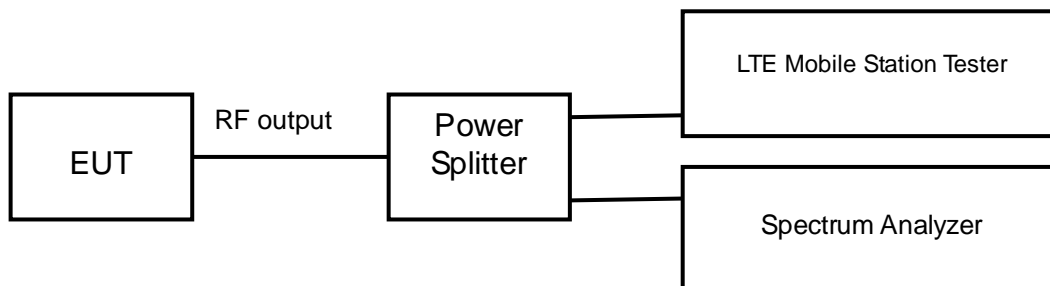

Test procedure:

After a radio link has been established between EUT and Tester, the output power of the cell signal of the testing equipment will be decreased until the output power of the EUT reach a maximum value. The measurement is carried out using a spectrum analyzer. The spectrum analyzer scans from 30MHz to 20GHz (higher than the 10th harmonic of the carrier). The peak detector is used and RBW is set to 1MHz on spectrum analyzer.

Limits	≤-13dBm
--------	---------

Test result:

The test results are shown in Appendix A.

## 6.7 Band Edges Compliance

Rule Part(s)

FCC: 2.1051, 22.359, 22.917, 24.238, 27.53

Ambient condition:

Temperature	Relative humidity	Pressure
23°C	42%	101.9kPa

Test Setup:

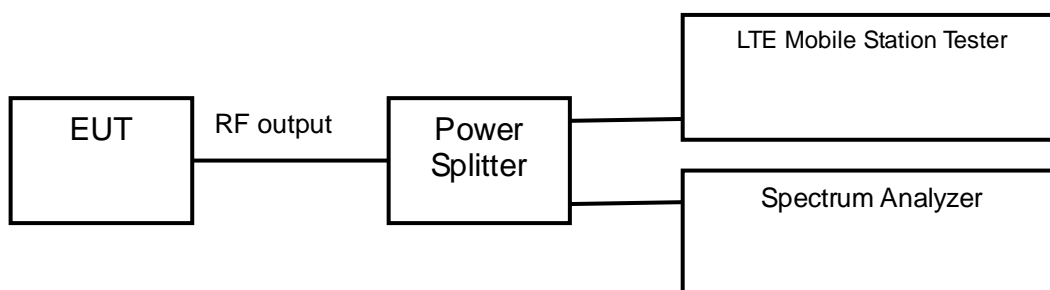

Test procedure:

After a radio link has been established between EUT and Tester, the output power of the cell signal of the testing equipment will be decreased until the output power of the EUT reach a maximum value. The measurement is carried out using a spectrum analyzer. The peak detector is used and RBW is set to at least 1% of the emission bandwidth on spectrum analyzer.

Limits	≤-13dBm

Test result:

The test results are shown in Appendix A.

## 6.8 Frequency Stability

Rule Part(s)

FCC: 2.1055, 22.355, 24.235, 27.54

Ambient condition:

Temperature	Relative humidity	Pressure
23°C	42%	101.9kPa

Test setup:

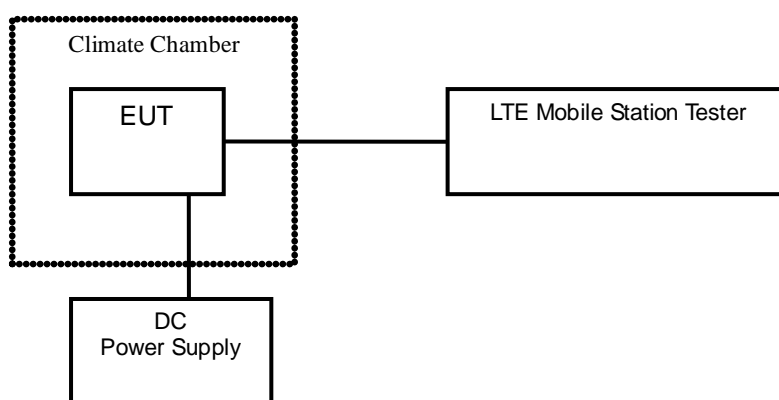

Test Procedure:

A radio link shall be established between EUT and Tester. The tester will sample the transmitter RF output signal and measure its frequency. The temperature inside the climate chamber is varied from -30 to +50°C in 10°C step size, and also the DC power supply voltage to the EUT is varied from LV to HV. The measurement will be conducted at three channels No18100, No18300 and No18500 (Bottom, middle and top channels of LTE band I).

Limits: No specific frequency stability requirements in part 2.1055 and part 22.355.

Test result:

The test results are shown in Appendix A.

## 6.9 Radiated Spurious Emissions

Rule Part(s)

FCC: 2.1053, 22.917, 24.238, 27.53

Ambient condition:

Temperature	Relative humidity	Pressure
20.8°C	36.5%	100.9kPa

Test Setup:

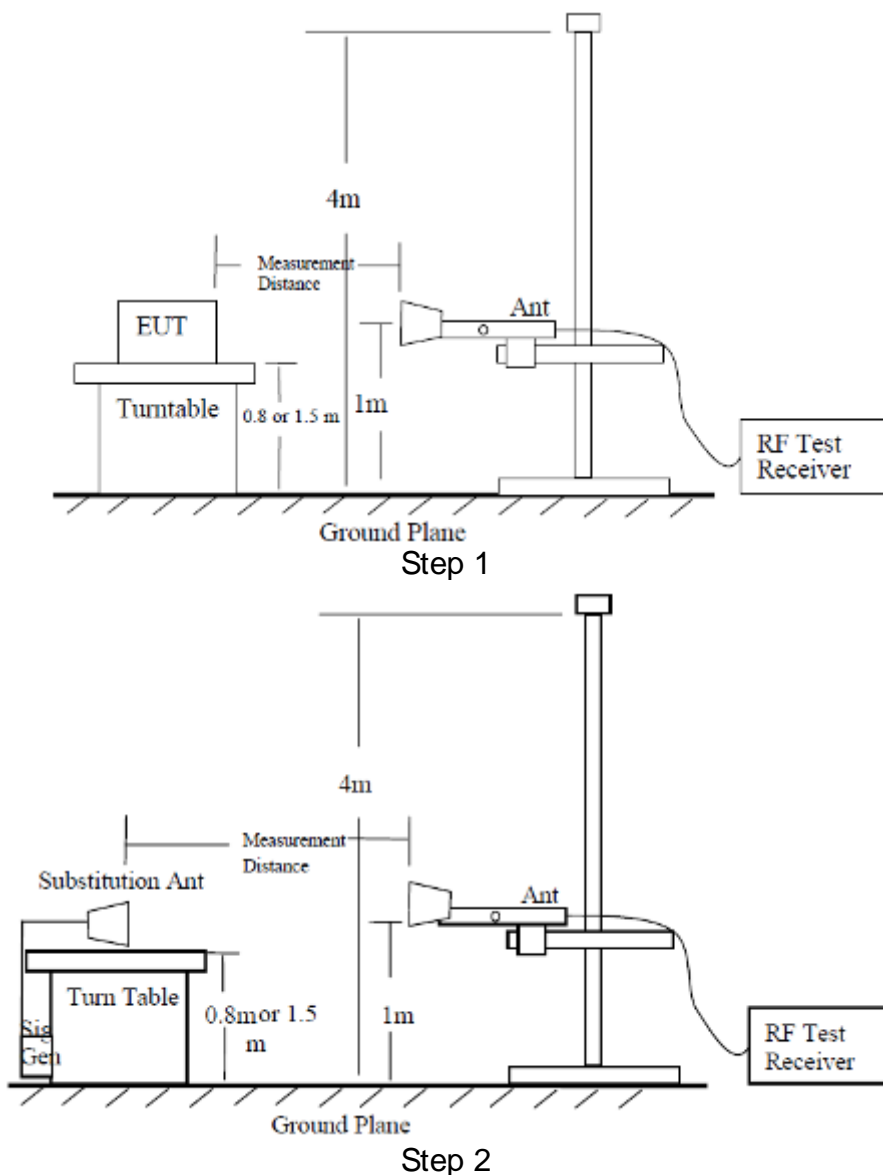

Test procedure:

The measurements procedures in TIA-603C-2004 are used.

The spectrum was scanned from 30MHz to the 10th harmonic of the highest frequency generated within the equipment.

Step 1:

The measurement is carried out in the fully anechoic chamber. EUT was placed on a 2.4 meter high non-conductive table at a 3 meter test distance from the test receive antenna. A receiving antenna was placed on the antenna mast 3 meters from the EUT. The height of receiving antenna is 2.4m and varies in certain range to find the maximum power value. A radio link shall be established between EUT and Tester. The output power of the cell signal of the tester will be decreased until the output power of the EUT reach a maximum value. The measurement is carried out using a spectrum analyzer or receiver. The spectrum analyzer scans from 30MHz to 20GHz (higher than the 10th harmonic of the carrier). The peak detector is used and RBW is set to 1MHz on spectrum analyzer. Then the antenna height and turn table rotation is adjusted till the maximum power value is founded on spectrum analyzer or receiver. A notch filter is necessary in the band near to the carrier frequency. A high pass filter is needed to avoid the distortion of the testing equipment in the band above the carrier frequency.

Step 2:

A log-periodic antenna or double-ridged waveguide horn antenna shall be substituted in place of the EUT. The log-periodic antenna will be driven by a signal generator and the level will be adjusted till the same power value on the spectrum analyzer or receiver. The level of the spurious emissions can be calculated through the level of the signal generator, cable loss, the gain of the substitution antenna and the reading of the spectrum analyzer or receiver.

A power ( $P_{mea}$ ) is applied to the input of the substitution antenna, and adjusts the level of the signal generator output until the value of the receiver reach the previously recorded ( $P_r$ ). The power of signal source ( $P_{mea}$ ) is recorded. The test should be performed by rotating the test item and adjusting the receiving antenna polarization.

A "reference path loss" should be calculated after test. The attenuation of "reference path loss" is the cable loss between the Signal Source with the Substitution Antenna ( $P_{ca}$ ) and the Substitution Antenna Gain ( $G_a$ ).

Calculation procedure:

The data of cable loss and antenna gain has been calibrated in full testing frequency range before the testing.

The power of the Radiated Spurious Emissions is calculated by adding the cable loss and antenna gain. The basic equation with a sample calculation is as followed:

$$\text{Power(EIRP)} = P_{mea} + P_{ca} + G_a$$

This value is EIRP since the measurement is calibrated using an antenna of known gain (2.15dB) and known input power. ERP can be calculated from EIRP by subtracting the gain of the dipole,  $ERP = EIRP - 2.15 \text{ (dB)}$ .

Assumed the power of signal source record is -20dBm. A cable loss of -30dB, and an antenna gain of 11dB are added.

$$P = P_{mea} + P_{ca} + G_a = (-20\text{dBm}) + (-30\text{dB}) + (11\text{dB}) = -39\text{dBm}$$

Test result:

The test results are shown in Appendix B.

## 7 MEASUREMENT UNCERTAINTIES

Items	Uncertainty	
RF Power Output	0.6 dB	
Occupied Bandwidth	3 kHz	
Spurious Emissions	30MHz~1GHz	2.83 dB
	1GHz~12.75GHz	2.50 dB
	12.75GHz~25GHz	2.75 dB
Band Edges Compliance	1.2dB	
Frequency Stability	4 Hz	

## **8 TEST EQUIPMENTS**

No.	Name/Model	Manufacturer	S/N	Calibration Date	Calibration Due Date
1	MT8820C Mobile Station Tester	Anritsu	6201300660	2018.08.20	2019.08.19
2	FSV40 Spectrum Analyzer	R&S	101065	2018.08.20	2019.08.19
2	N9020A Spectrum Analyzer	Agilent	MY48010771	2018.08.20	2019.08.19
3	6007 Power Divider	Weinschel	6007-GJ-1	2018.08.20	2019.08.19
4	DC Power Supply E3645A	Agilent	MY40000741	2019.03.01	2020.02.28
5	Temperature chamber SH241	ESPEC	92013758	2018.08.20	2019.08.19
6	12.65m×8.03m×7.50m Fully-Anechoic Chamber	FRANKONIA	----	----	----
7	23.18m×16.88m×9.60m Semi-Anechoic Chamber	FRANKONIA	---	----	----
8	Turn table Diameter: 1m	FRANKONIA	----	----	----
9	Turn table Diameter: 5m	FRANKONIA	----	----	----
10	Antenna master FAC(MA4.0)	MATURO	----	----	----
11	Antenna master SAC(MA4.0)	MATURO	----	----	----
12	9.080m×5.255m×3.525m Shielding room	FRANKONIA	----	----	----
13	HF 907 Double-Ridged Waveguide Horn Antenna	R&S	100512	2018.08.20	2019.08.19
14	HF 907 Double-Ridged Waveguide Horn Antenna	R&S	100513	2018.08.20	2019.08.19
15	HL562 Ultra log antenna	R&S	100016	2018.08.20	2019.08.19
16	3160-09 Receive antenna	SCHWARZ-BECK	002058-002	2018.08.20	2019.08.19
17	ESI 40 EMI test receiver	R&S	100015	2018.08.20	2019.08.19
18	ESCS30 EMI test receiver	R&S	100029	2018.08.20	2019.08.19
19	HL562 Receive antenna	R&S	100167	2018.08.20	2019.08.19
20	ENV216 AMN	R&S	3560.6550.12	2018.08.20	2019.08.19

### **APPENDIX A – TEST DATA OF CONDUCTED EMISSION**

Please refer to the attachment.

### **APPENDIX B – TEST DATA OF RADIATED EMISSION**

Please refer to the attachment.

## APPENDIX A – TEST DATA OF CONDUCTED EMISSION

### LTE Band 2

#### 1 RF Power Output

Main ANT and DIV ANT are TX diversity switching.

Main Antenna Gain=-9.5dBi

Modulation	Carrier frequency (MHz)	UL Channel	BW	RB Size	RB Offset	Conducted power (dBm)	Main-Ant EIRP (W)
QPSK	1850.7	18607	1.4	1	0	22.1	0.018
				1	5	22.1	0.018
				3	2	21.9	0.017
				6	0	21.1	0.014
	1880	18900		1	0	22.1	0.018
				1	5	22.1	0.018
				3	2	22.1	0.018
				6	0	21.3	0.015
	1909.3	19193		1	0	22.3	0.019
				1	5	22.3	0.019
				3	2	22.2	0.019
				6	0	21.3	0.015
Modulation	Carrier frequency (MHz)	UL Channel	BW	RB Size	RB Offset	Conducted power (dBm)	Main-Ant EIRP (W)
16QAM	1850.7	18607	1.4	1	0	20.8	0.013
				1	5	20.6	0.013
				3	2	20.0	0.011
				6	0	19.9	0.011
	1880	18900		1	0	20.6	0.013
				1	5	20.8	0.013
				3	2	20.0	0.011
				6	0	20.0	0.011
	1909.3	19193		1	0	20.7	0.013
				1	5	20.6	0.013
				3	2	20.2	0.012
				6	0	19.1	0.009
Modulation	Carrier frequency (MHz)	UL Channel	BW	RB Size	RB Offset	Conducted power (dBm)	Main-Ant EIRP (W)
64QAM	1850.7	18607	1.4	1	0	20.2	0.012
				1	5	20.8	0.013
				3	2	19.9	0.011
				6	0	19.9	0.011
	1880	18900		1	0	20.5	0.013
				1	5	20.5	0.013
				3	2	20.1	0.011
				6	0	19.9	0.011
	1909.3	19193		1	0	20.2	0.012
				1	5	20.4	0.012
				3	2	20.0	0.011
				6	0	20.1	0.011



Modulation	Carrier frequency (MHz)	UL Channel	BW	RB Size	RB Offset	Conducted power (dBm)	Main-Ant EIRP (W)
QPSK	1851.5	18615	3	1	0	21.9	0.017
				1	14	21.9	0.017
				8	4	21.0	0.014
				15	0	20.8	0.013
	1880	18900		1	0	22.0	0.018
				1	14	22.0	0.018
				8	4	21.1	0.014
				15	0	21.0	0.014
	1908.5	19185		1	0	22.1	0.018
				1	14	22.1	0.018
				8	4	21.2	0.015
				15	0	21.1	0.014
Modulation	Carrier frequency (MHz)	UL Channel	BW	RB Size	RB Offset	Conducted power (dBm)	Main-Ant EIRP (W)
16QAM	1851.5	18615	3	1	0	20.4	0.012
				1	14	20.4	0.012
				8	4	19.9	0.011
				15	0	19.8	0.011
	1880	18900		1	0	20.9	0.014
				1	14	20.9	0.014
				8	4	20.0	0.011
				15	0	20.1	0.011
	1908.5	19185		1	0	20.7	0.013
				1	14	20.7	0.013
				8	4	20.0	0.011
				15	0	20.0	0.011
Modulation	Carrier frequency (MHz)	UL Channel	BW	RB Size	RB Offset	Conducted power (dBm)	Main-Ant EIRP (W)
64QAM	1851.5	18615	3	1	0	20.4	0.012
				1	14	20.4	0.012
				8	4	19.6	0.010
				15	0	20.1	0.011
	1880	18900		1	0	20.8	0.013
				1	14	20.8	0.013
				8	4	19.9	0.011
				15	0	19.8	0.011
	1908.5	19185		1	0	20.9	0.014
				1	14	20.9	0.014
				8	4	20.0	0.011
				15	0	20.0	0.011

Modulation	Carrier frequency (MHz)	UL Channel	BW	RB Size	RB Offset	Conducted power (dBm)	Main-Ant EIRP (W)
QPSK	1852.5	18625	5	1	0	21.8	0.017
				1	24	21.8	0.017
				12	6	20.8	0.013
				25	0	20.8	0.013
	1880	18900		1	0	21.8	0.017
				1	24	21.8	0.017
				12	6	21.0	0.014
				25	0	21.0	0.014
	1907.5	19175		1	0	22.1	0.018
				1	24	22.1	0.018
				12	6	21.1	0.014
				25	0	21.1	0.014
Modulation	Carrier frequency (MHz)	UL Channel	BW	RB Size	RB Offset	Conducted power (dBm)	Main-Ant EIRP (W)
16QAM	1852.5	18625	5	1	0	20.2	0.012
				1	24	20.2	0.012
				12	6	19.7	0.010
				25	0	19.8	0.011
	1880	18900		1	0	20.3	0.012
				1	24	20.3	0.012
				12	6	19.9	0.011
				25	0	20.1	0.011
	1907.5	19175		1	0	20.5	0.013
				1	24	20.5	0.013
				12	6	20.0	0.011
				25	0	20.0	0.011
Modulation	Carrier frequency (MHz)	UL Channel	BW	RB Size	RB Offset	Conducted power (dBm)	Main-Ant EIRP (W)
64QAM	1852.5	18625	5	1	0	20.5	0.013
				1	24	20.5	0.013
				12	6	19.6	0.010
				25	0	19.7	0.010
	1880	18900		1	0	20.6	0.013
				1	24	20.6	0.013
				12	6	20.0	0.011
				25	0	20.1	0.011
	1907.5	19175		1	0	20.6	0.013
				1	24	20.6	0.013
				12	6	20.1	0.011
				25	0	20.1	0.011

Modulation	Carrier frequency (MHz)	UL Channel	BW	RB Size	RB Offset	Conducted power (dBm)	Main-Ant EIRP (W)
QPSK	1855	18650	10	1	0	21.9	0.017
				1	49	21.9	0.017
				24	12	20.9	0.014
				50	0	20.8	0.013
	1880	18900		1	0	22.0	0.018
				1	49	22.0	0.018
				24	12	21.1	0.014
				50	0	21.0	0.014
	1905	19150		1	0	22.1	0.018
				1	49	22.1	0.018
				24	12	21.1	0.014
				50	0	21.1	0.014
Modulation	Carrier frequency (MHz)	UL Channel	BW	RB Size	RB Offset	Conducted power (dBm)	Main-Ant EIRP (W)
16QAM	1855	18650	10	1	0	20.2	0.012
				1	49	20.2	0.012
				24	12	20.0	0.011
				50	0	19.8	0.011
	1880	18900		1	0	20.6	0.013
				1	49	20.6	0.013
				24	12	20.1	0.011
				50	0	20.1	0.011
	1905	19150		1	0	20.6	0.013
				1	49	20.6	0.013
				24	12	20.1	0.011
				50	0	19.9	0.011
Modulation	Carrier frequency (MHz)	UL Channel	BW	RB Size	RB Offset	Conducted power (dBm)	Main-Ant EIRP (W)
64QAM	1855	18650	10	1	0	20.5	0.013
				1	49	20.5	0.013
				24	12	20.0	0.011
				50	0	19.8	0.011
	1880	18900		1	0	20.4	0.012
				1	49	20.4	0.012
				24	12	20.0	0.011
				50	0	20.0	0.011
	1905	19150		1	0	20.3	0.012
				1	49	20.3	0.012
				24	12	20.0	0.011
				50	0	20.1	0.011

Modulation	Carrier frequency (MHz)	UL Channel	BW	RB Size	RB Offset	Conducted power (dBm)	Main-Ant EIRP (W)
QPSK	1857.5	18675	15	1	0	22.0	0.018
				1	74	22.0	0.018
				40	18	21.0	0.014
				75	0	20.8	0.013
	1880	18900		1	0	22.1	0.018
				1	74	22.1	0.018
				40	18	21.1	0.014
				75	0	21.0	0.014
	1902.5	19125		1	0	22.1	0.018
				1	74	22.1	0.018
				40	18	21.2	0.015
				75	0	21.0	0.014
Modulation	Carrier frequency (MHz)	UL Channel	BW	RB Size	RB Offset	Conducted power (dBm)	Main-Ant EIRP (W)
16QAM	1857.5	18675	15	1	0	20.2	0.012
				1	74	20.2	0.012
				40	18	19.7	0.010
				75	0	19.8	0.011
	1880	18900		1	0	20.3	0.012
				1	74	20.3	0.012
				40	18	20.1	0.011
				75	0	20.0	0.011
	1902.5	19125		1	0	20.7	0.013
				1	74	20.7	0.013
				40	18	20.0	0.011
				75	0	20.0	0.011
Modulation	Carrier frequency (MHz)	UL Channel	BW	RB Size	RB Offset	Conducted power (dBm)	Main-Ant EIRP (W)
64QAM	1857.5	18675	15	1	0	20.2	0.012
				1	74	20.2	0.012
				40	18	19.9	0.011
				75	0	19.8	0.011
	1880	18900		1	0	20.4	0.012
				1	74	20.4	0.012
				40	18	20.2	0.012
				75	0	20.0	0.011
	1902.5	19125		1	0	20.1	0.011
				1	74	20.1	0.011
				40	18	19.9	0.011
				75	0	19.9	0.011

Modulation	Carrier frequency (MHz)	UL Channel	BW	RB Size	RB Offset	Conducted power (dBm)	Main-Ant EIRP (W)
QPSK	1860	18700	20	1	0	22.0	0.018
				1	99	22.0	0.018
				50	25	21.1	0.014
				100	0	21.0	0.014
	1880	18900		1	0	22.3	0.019
				1	99	22.3	0.019
				50	25	21.2	0.015
				100	0	21.0	0.014
	1900	19100		1	0	22.2	0.019
				1	99	22.2	0.019
				50	25	21.1	0.014
				100	0	21.1	0.014
Modulation	Carrier frequency (MHz)	UL Channel	BW	RB Size	RB Offset	Conducted power (dBm)	Main-Ant EIRP (W)
16QAM	1860	18700	20	1	0	20.8	0.013
				1	99	20.8	0.013
				50	25	20.6	0.013
				100	0	19.8	0.011
	1880	18900		1	0	21.5	0.016
				1	99	21.5	0.016
				50	25	20.8	0.013
				100	0	20.1	0.011
	1900	19100		1	0	21.0	0.014
				1	99	21.0	0.014
				50	25	20.7	0.013
				100	0	19.9	0.011
Modulation	Carrier frequency (MHz)	UL Channel	BW	RB Size	RB Offset	Conducted power (dBm)	Main-Ant EIRP (W)
64QAM	1860	18700	20	1	0	21.0	0.014
				1	99	21.0	0.014
				50	25	20.5	0.013
				100	0	19.8	0.011
	1880	18900		1	0	21.1	0.014
				1	99	21.1	0.014
				50	25	20.9	0.014
				100	0	19.9	0.011
	1900	19100		1	0	21.1	0.014
				1	99	21.1	0.014
				50	25	20.9	0.014
				100	0	20.1	0.011

## 2 Occupied Bandwidth

### Test result

Band	Carrier frequency (MHz)	Channel(Low)	BW	RB Size	RB Offset	Bandwidth of 99% Power (MHz)					
						QPSK		16-QAM		64-QAM	
2	1850.7	18607	1.4	6	0	1.0964	Fig.1	1.1005	Fig.2	1.0960	Fig.3
2	1880.0	18900	1.4	6	0	1.0949	Fig.4	1.0981	Fig.5	1.0950	Fig.6
2	1909.3	19193	1.4	6	0	1.0970	Fig.7	1.0998	Fig.8	1.0981	Fig.9

Band	Carrier frequency (MHz)	Channel(Low)	BW	RB Size	RB Offset	Bandwidth of -26dB transmitter power (MHz)					
						QPSK		16-QAM		64-QAM	
2	1850.7	18607	1.4	6	0	1.276	Fig.1	1.305	Fig.2	1.310	Fig.3
2	1880.0	18900	1.4	6	0	1.281	Fig.4	1.299	Fig.5	1.321	Fig.6
2	1909.3	19193	1.4	6	0	1.290	Fig.7	1.313	Fig.8	1.315	Fig.9

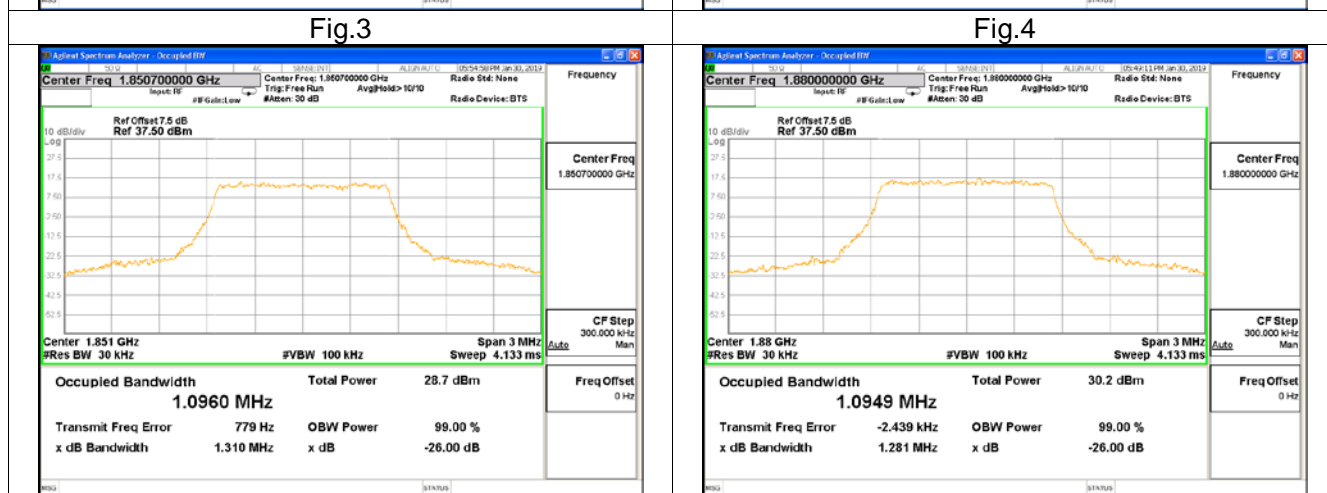
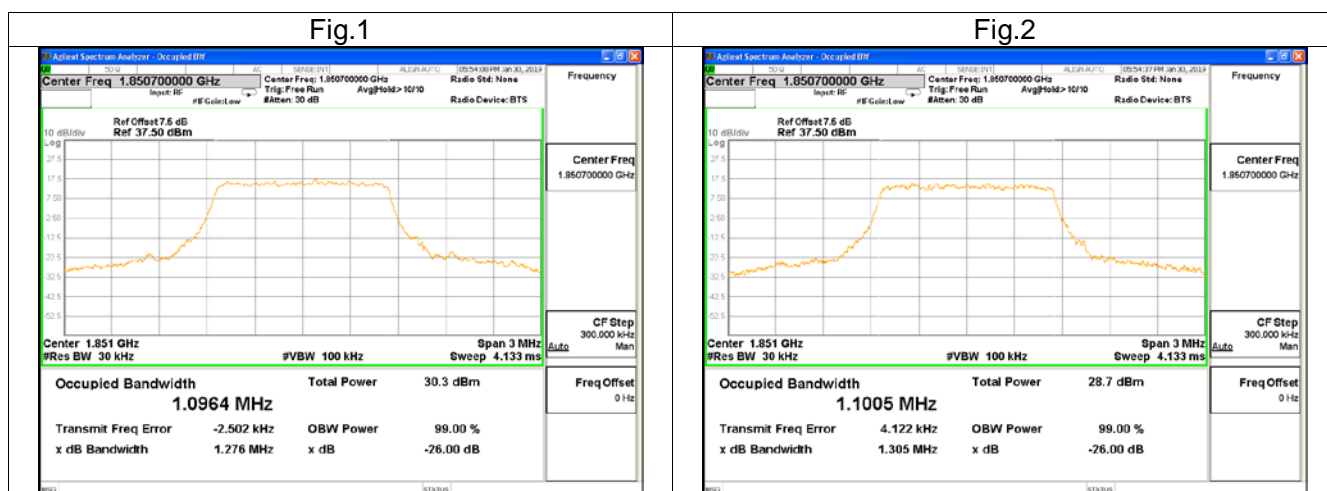

Fig.5

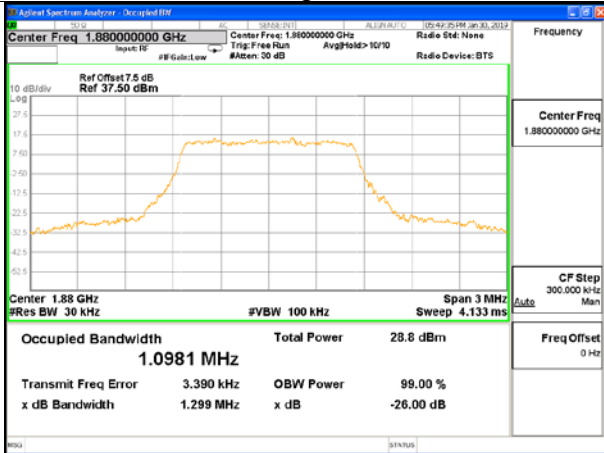

Fig.6

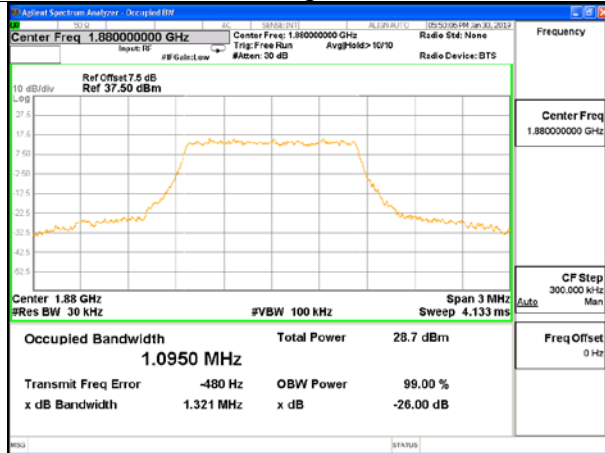

Fig.7

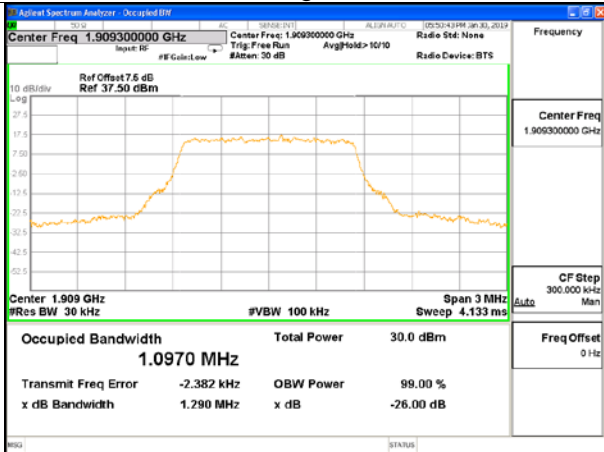

Fig.8

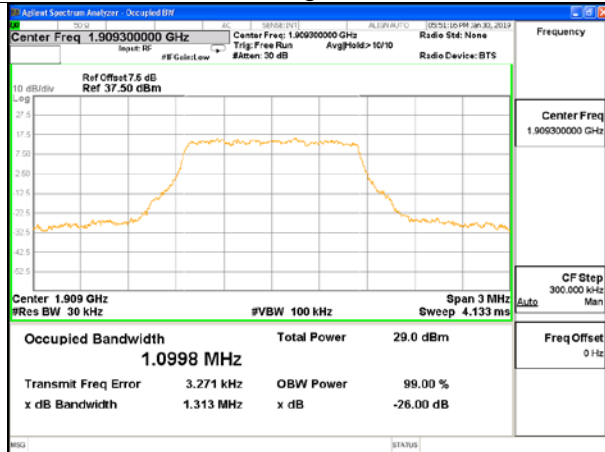
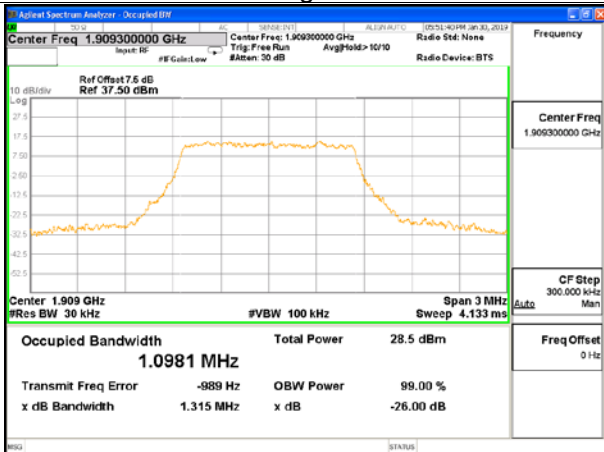

Fig.9



Band	Carrier frequency (MHz)	Channel(Low)	BW	RB Size	RB Offset	Bandwidth of 99% Power (MHz)					
						QPSK		16-QAM		64-QAM	
2	1851.5	18615	3	15	0	2.6774	Fig.1	2.6834	Fig.2	2.6835	Fig.3
2	1880.0	18900	3	15	0	2.7310	Fig.4	2.7259	Fig.5	2.7335	Fig.6
2	1908.5	19185	3	15	0	2.6779	Fig.7	2.6823	Fig.8	2.6827	Fig.9

Band	Carrier frequency (MHz)	Channel(Low)	BW	RB Size	RB Offset	Bandwidth of -26dB transmitter power (MHz)					
						QPSK		16-QAM		64-QAM	
2	1851.5	18615	3	15	0	2.936	Fig.1	2.925	Fig.2	2.945	Fig.3
2	1880.0	18900	3	15	0	3.067	Fig.4	3.066	Fig.5	3.054	Fig.6
2	1908.5	19185	3	15	0	2.928	Fig.7	2.941	Fig.8	2.944	Fig.9

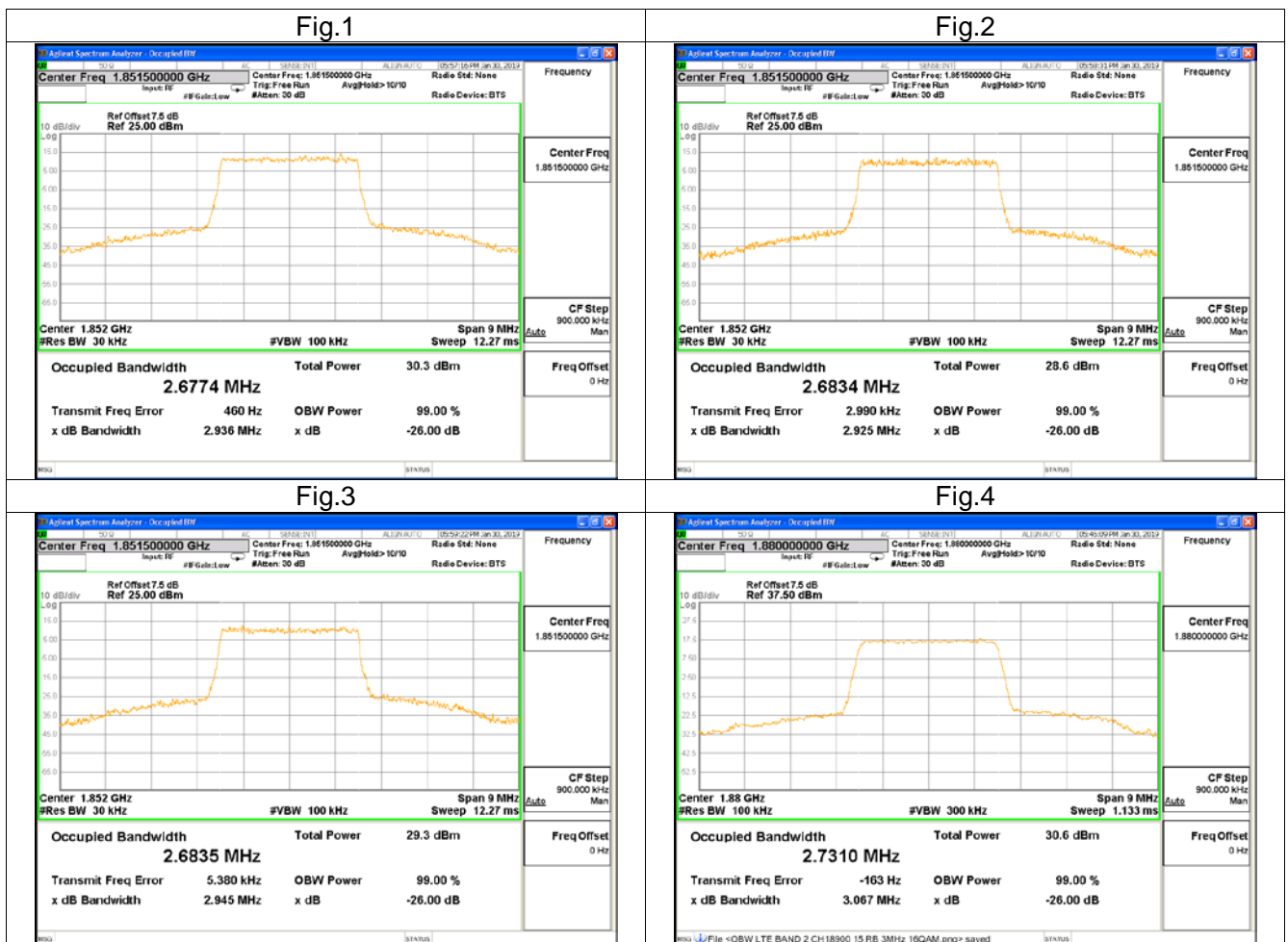



Fig.5

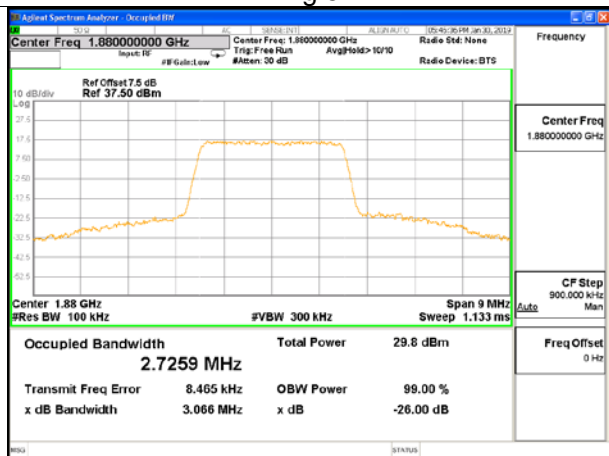

Fig.6

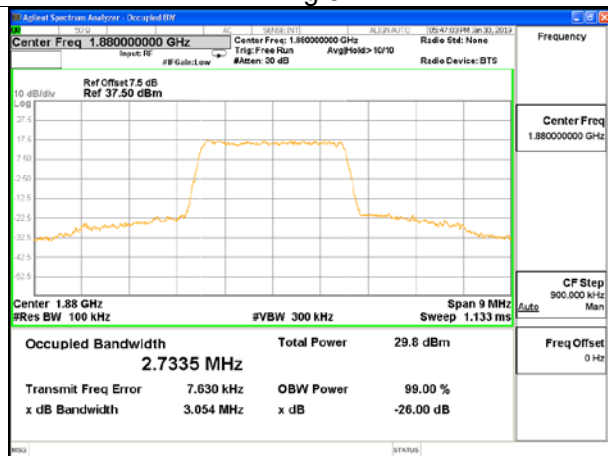

Fig.7

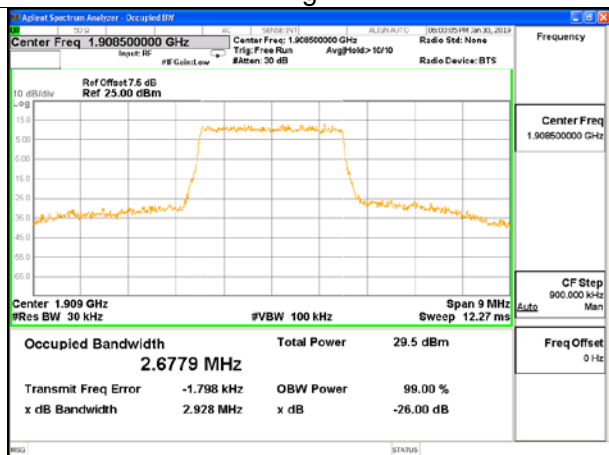

Fig.8

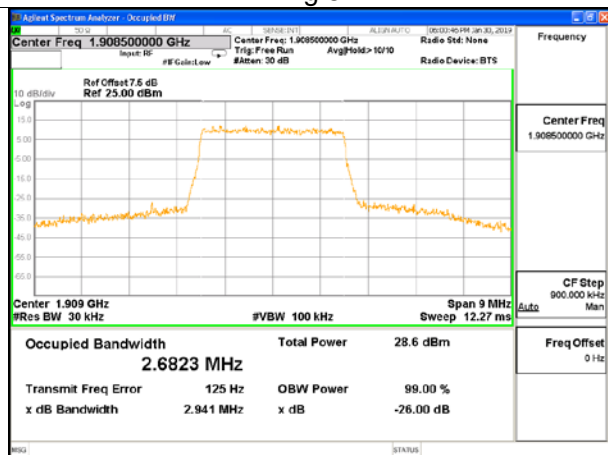
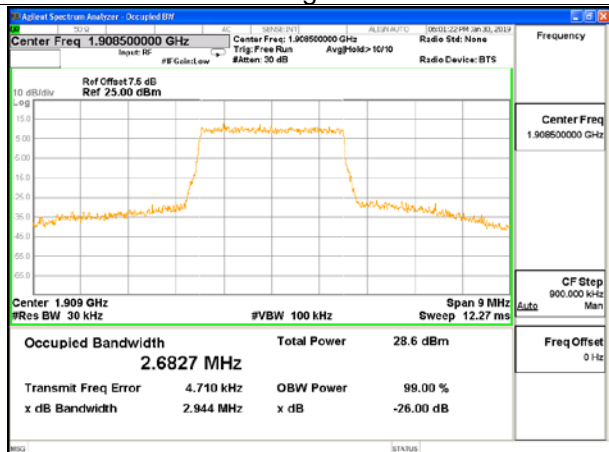

Fig.9



Band	Carrier frequency (MHz)	Channel(Low)	BW	RB Size	RB Offset	Bandwidth of 99% Power (MHz)					
						QPSK		16-QAM		64-QAM	
2	1852.5	18625	5	25	0	4.5038	Fig.1	4.4939	Fig.2	4.4895	Fig.3
2	1880.0	18900	5	25	0	4.4999	Fig.4	4.4984	Fig.5	4.5029	Fig.6
2	1907.5	19175	5	25	0	4.5004	Fig.7	4.4986	Fig.8	4.4962	Fig.9

Band	Carrier frequency (MHz)	Channel(Low)	BW	RB Size	RB Offset	Bandwidth of -26dB transmitter power (MHz)					
						QPSK		16-QAM		64-QAM	
2	1852.5	18625	5	25	0	5.028	Fig.1	4.992	Fig.2	4.980	Fig.3
2	1880.0	18900	5	25	0	5.039	Fig.4	4.965	Fig.5	4.980	Fig.6
2	1907.5	19175	5	25	0	5.072	Fig.7	5.011	Fig.8	4.990	Fig.9

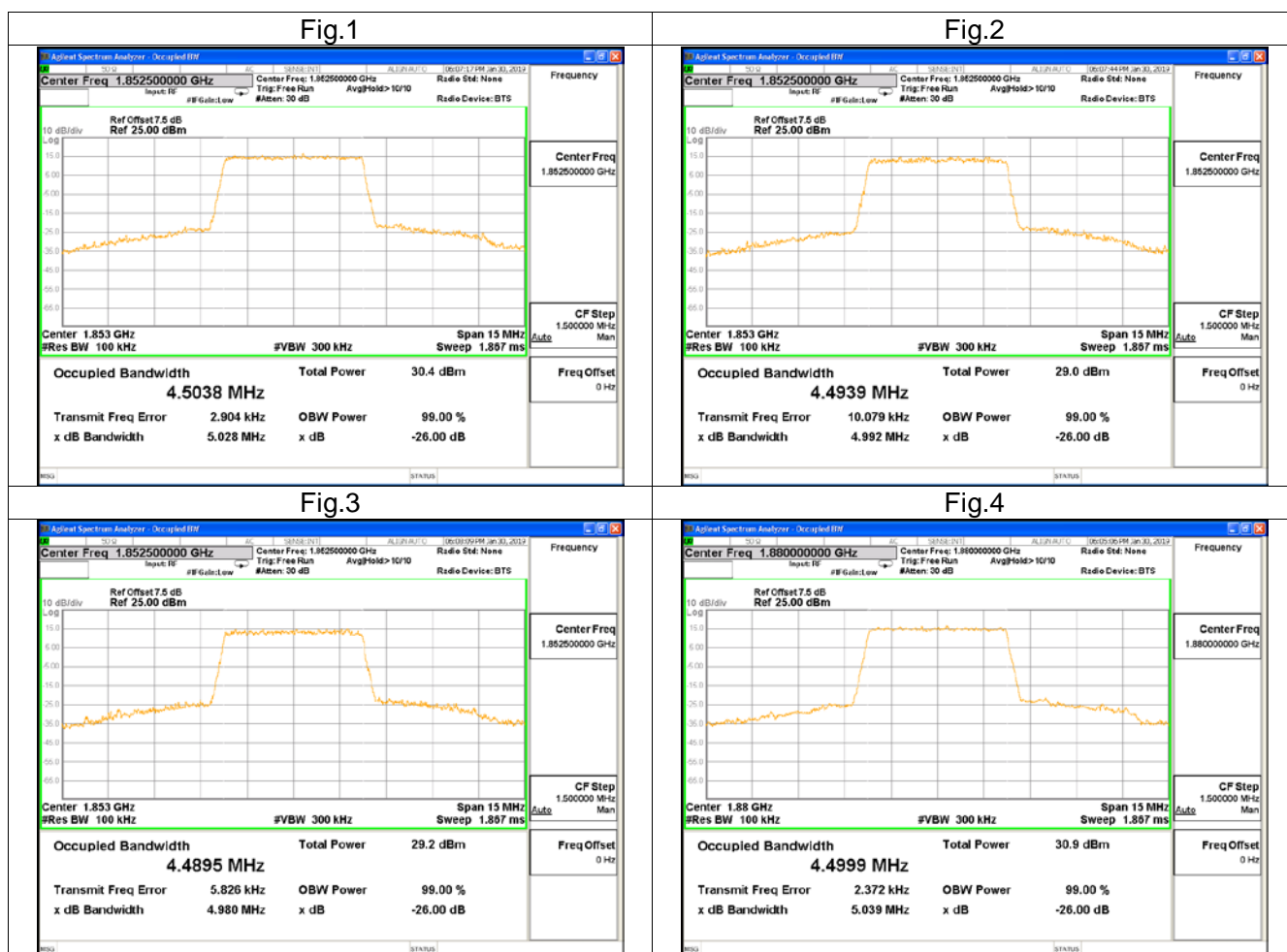

Fig.5

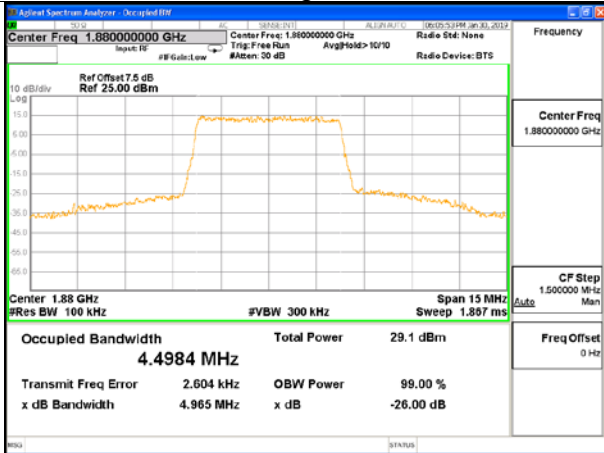

Fig.6

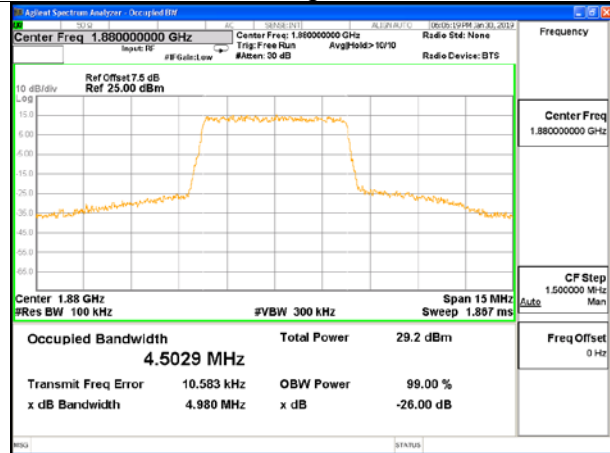

Fig.7

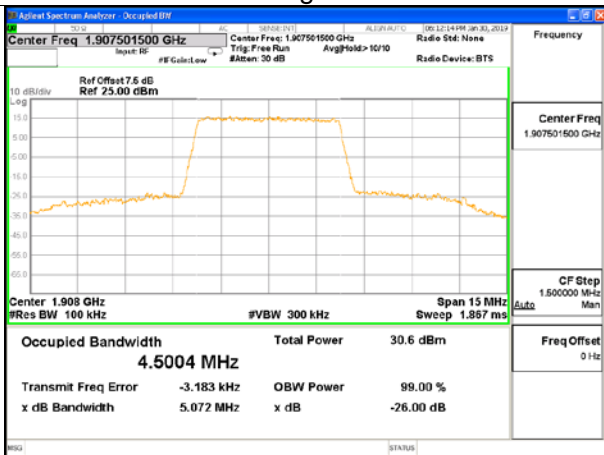

Fig.8

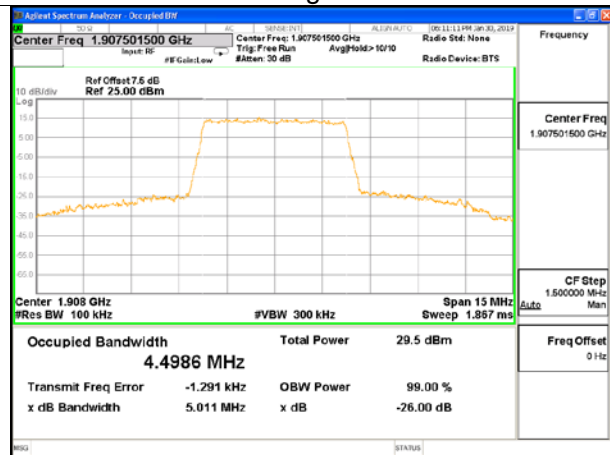
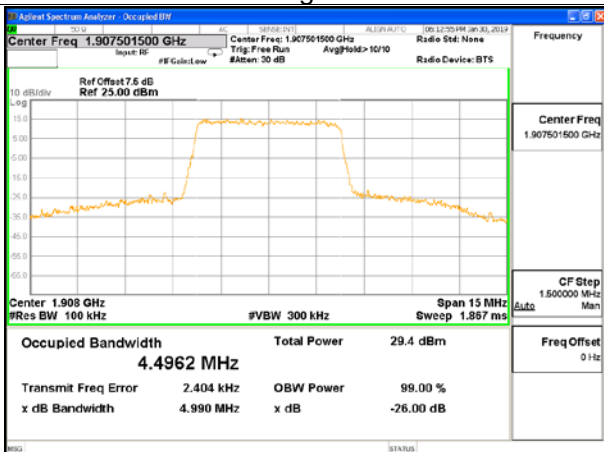

Fig.9



Band	Carrier frequency (MHz)	Channel(Low)	BW	RB Size	RB Offset	Bandwidth of 99% Power (MHz)					
						QPSK		16-QAM		64-QAM	
2	1855	18650	10	50	0	9.0686	Fig.1	9.0151	Fig.2	9.0247	Fig.3
2	1880	18900	10	50	0	9.0650	Fig.4	8.9960	Fig.5	9.0150	Fig.6
2	1905	19150	10	50	0	9.0299	Fig.7	8.9893	Fig.8	9.0000	Fig.9

Band	Carrier frequency (MHz)	Channel(Low)	BW	RB Size	RB Offset	Bandwidth of -26dB transmitter power (MHz)					
						QPSK		16-QAM		64-QAM	
2	1855	18650	10	50	0	9.977	Fig.1	9.965	Fig.2	9.963	Fig.3
2	1880	18900	10	50	0	10.01	Fig.4	9.921	Fig.5	9.965	Fig.6
2	1905	19150	10	50	0	10.06	Fig.7	9.943	Fig.8	9.959	Fig.9

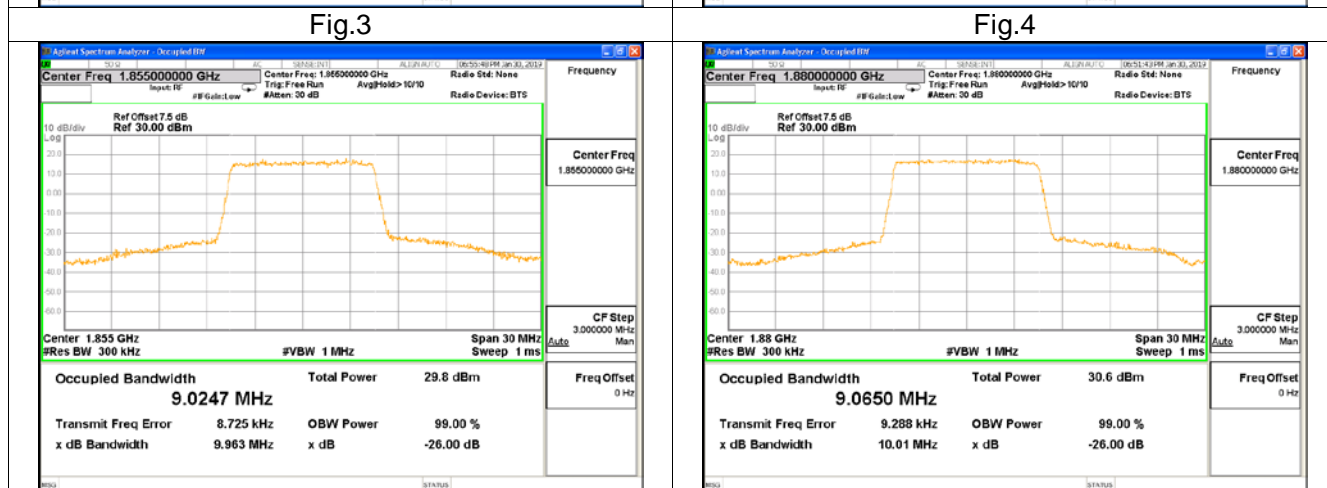
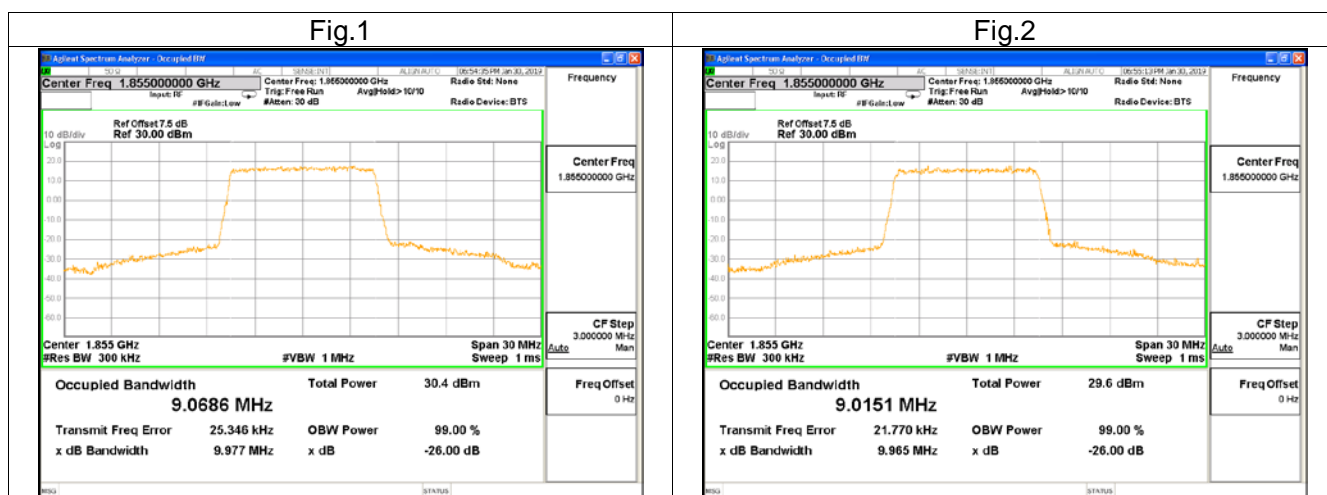

Fig.5

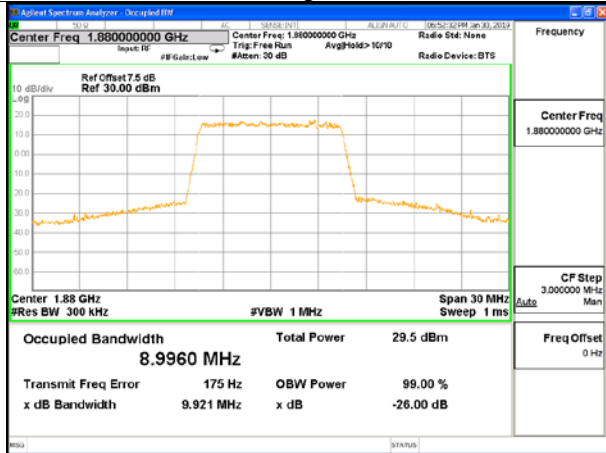

Fig.6

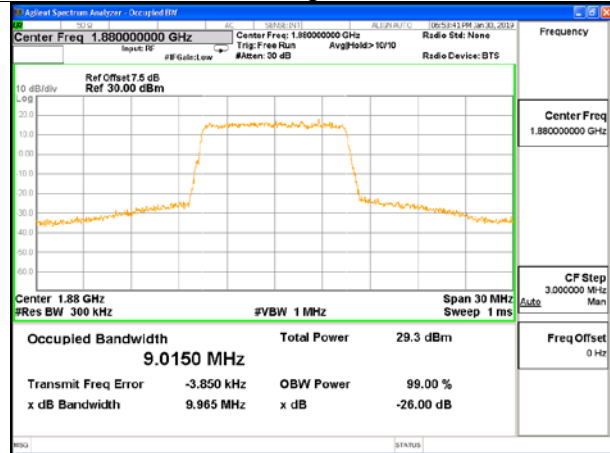

Fig.7

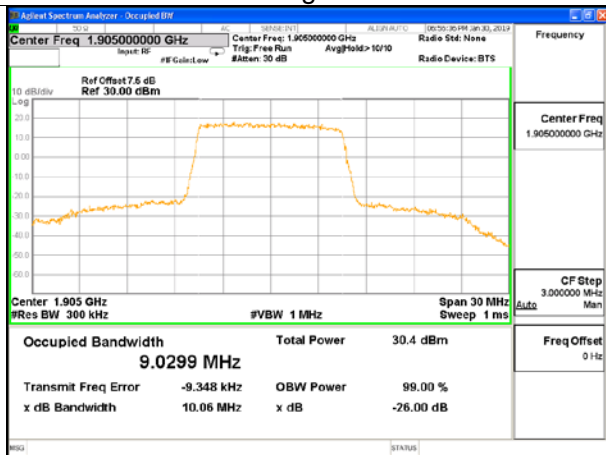

Fig.8

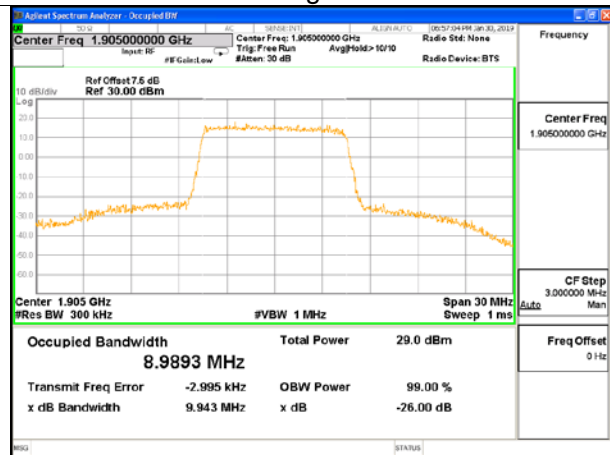
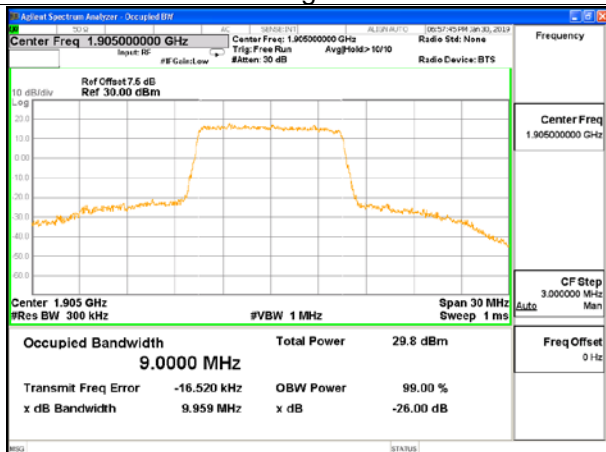

Fig.9



Band	Carrier frequency (MHz)	Channel(Low)	BW	RB Size	RB Offset	Bandwidth of 99% Power (MHz)					
						QPSK		16-QAM		64-QAM	
2	1857.5	18675	15	75	0	13.422	Fig.1	13.421	Fig.2	13.432	Fig.3
2	1880.0	18900	15	75	0	13.446	Fig.4	13.430	Fig.5	13.447	Fig.6
2	1902.5	19125	15	75	0	13.391	Fig.7	13.408	Fig.8	13.418	Fig.9

Band	Carrier frequency (MHz)	Channel(Low)	BW	RB Size	RB Offset	Bandwidth of -26dB transmitter power (MHz)					
						QPSK		16-QAM		64-QAM	
2	1857.5	18675	15	75	0	14.68	Fig.1	14.65	Fig.2	14.60	Fig.3
2	1880.0	18900	15	75	0	14.73	Fig.4	14.68	Fig.5	14.65	Fig.6
2	1902.5	19125	15	75	0	14.70	Fig.7	14.62	Fig.8	14.54	Fig.9

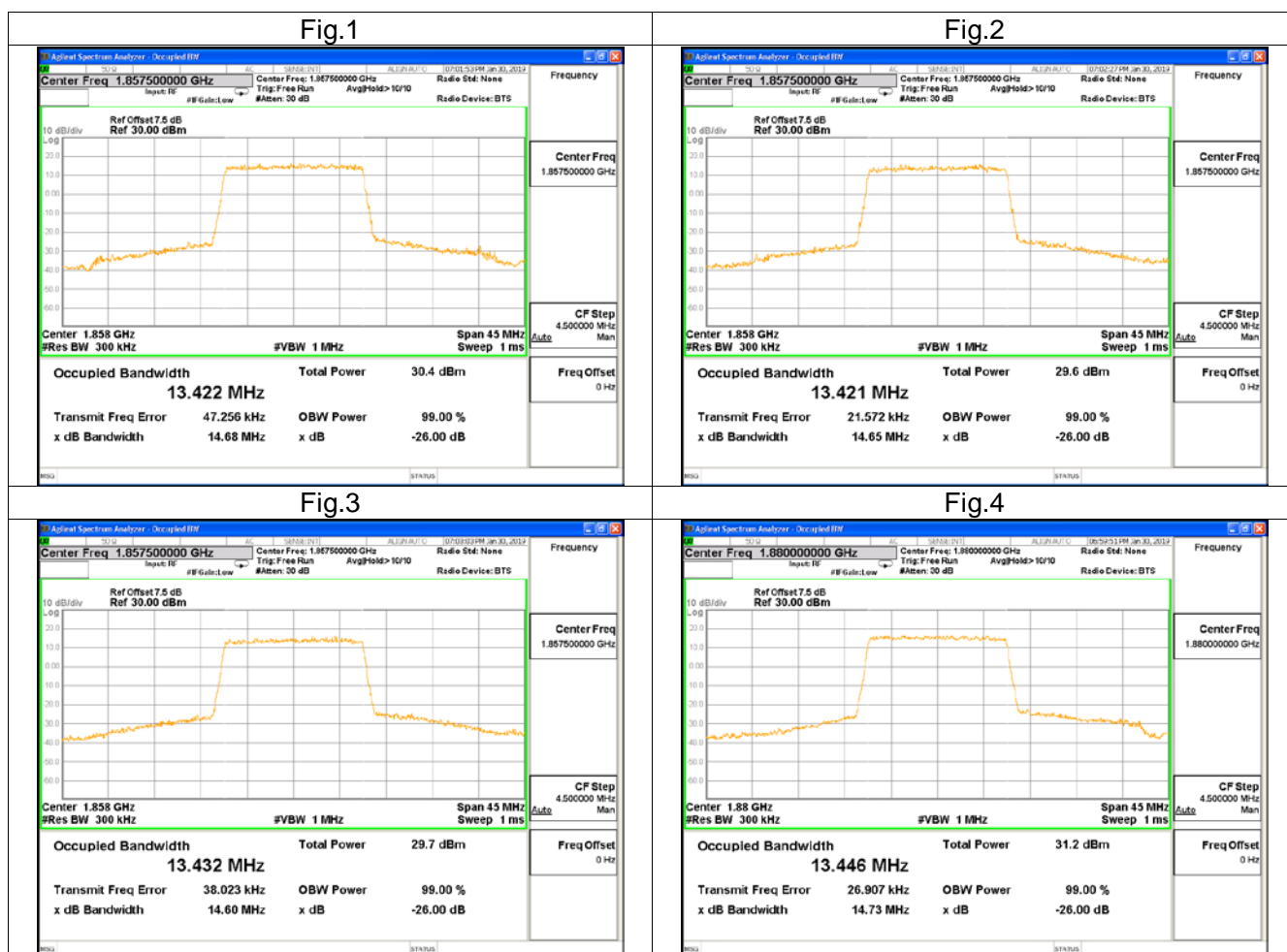

Fig.5

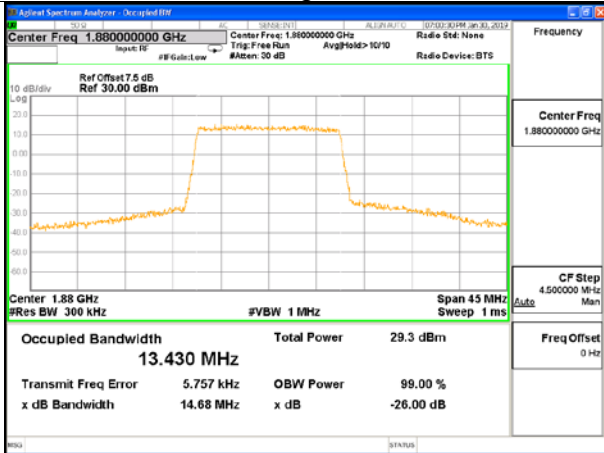

Fig.6

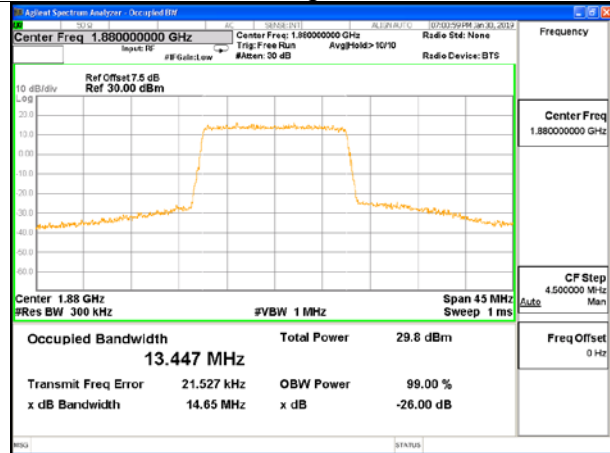

Fig.7

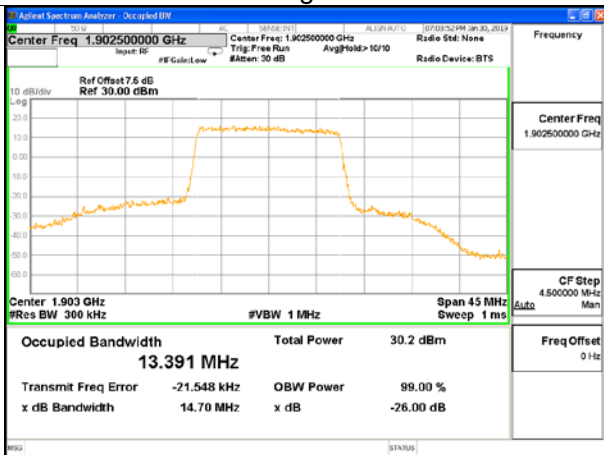

Fig.8

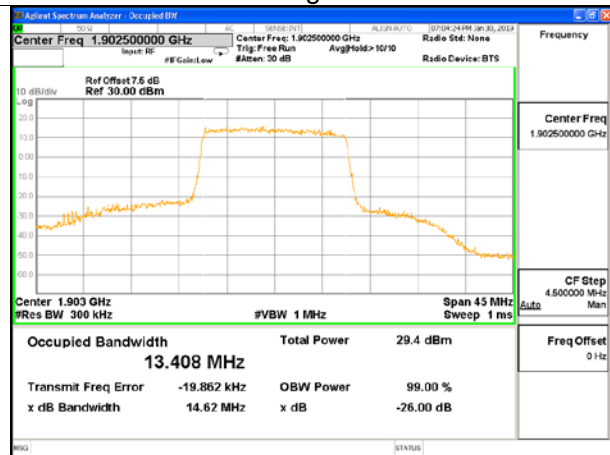
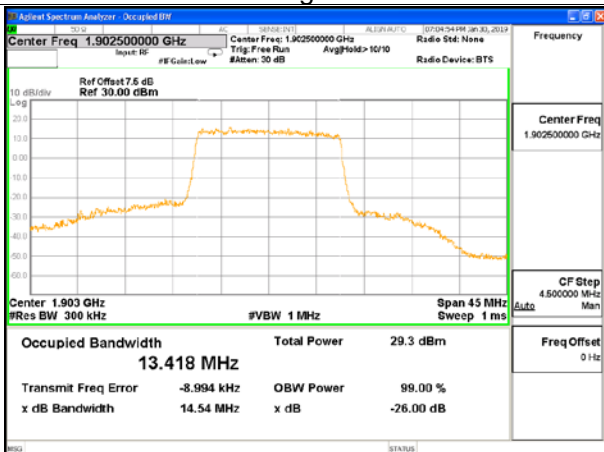

Fig.9



Band	Carrier frequency (MHz)	Channel(Low)	BW	RB Size	RB Offset	Bandwidth of 99% Power (MHz)					
						QPSK		16-QAM		64-QAM	
2	1860	18700	20	100	0	17.823	Fig.1	17.824	Fig.2	17.841	Fig.3
2	1880	18900	20	100	0	17.837	Fig.4	17.840	Fig.5	17.861	Fig.6
2	1900	19100	20	100	0	17.770	Fig.7	17.842	Fig.8	17.765	Fig.9

Band	Carrier frequency (MHz)	Channel(Low)	BW	RB Size	RB Offset	Bandwidth of -26dB transmitter power (MHz)					
						QPSK		16-QAM		64-QAM	
2	1860	18700	20	100	0	19.24	Fig.1	19.13	Fig.2	19.10	Fig.3
2	1880	18900	20	100	0	19.14	Fig.4	19.25	Fig.5	19.19	Fig.6
2	1900	19100	20	100	0	19.22	Fig.7	19.20	Fig.8	19.19	Fig.9

Fig.1

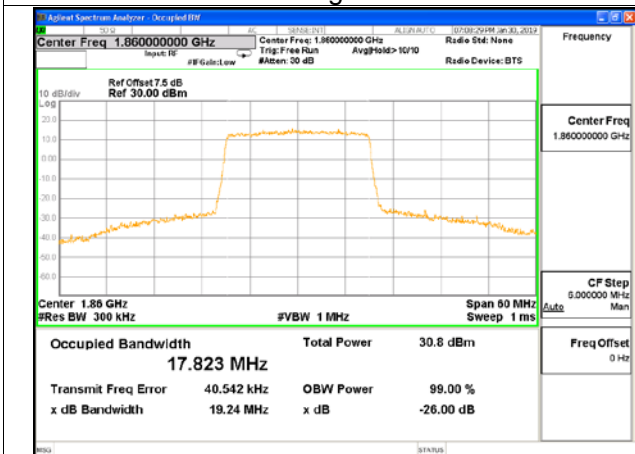

Fig.2

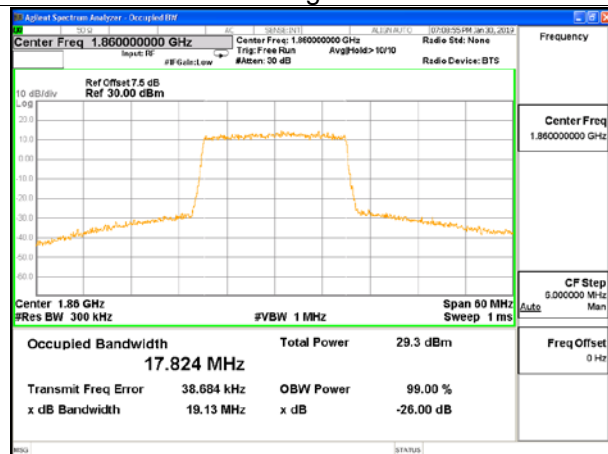

Fig.3

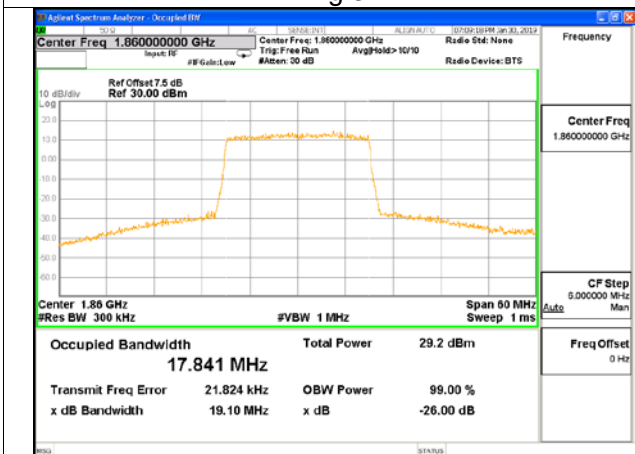

Fig.4

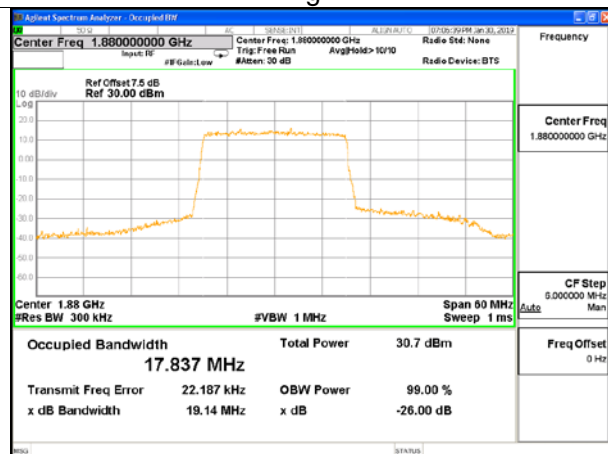



Fig.5

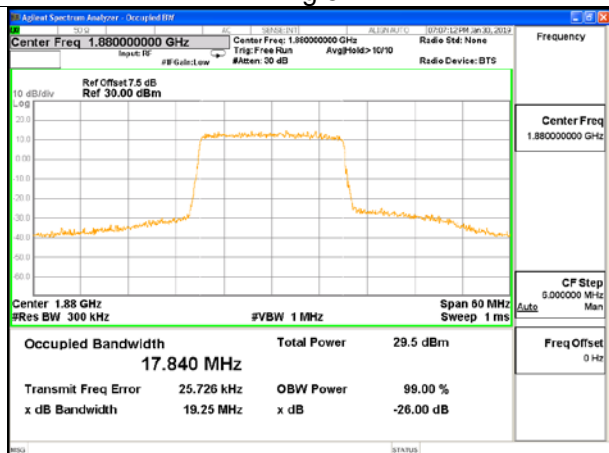

Fig.6

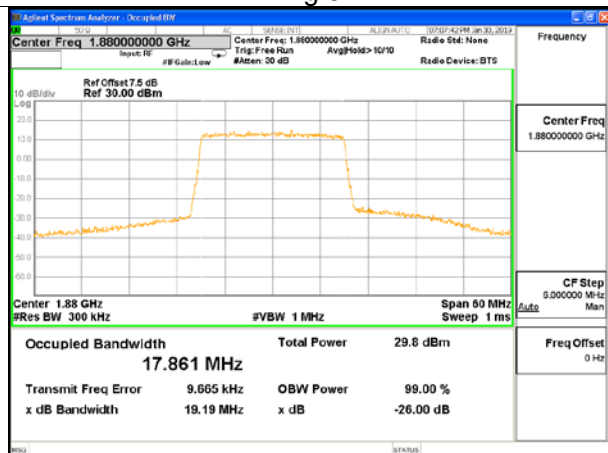

Fig.7

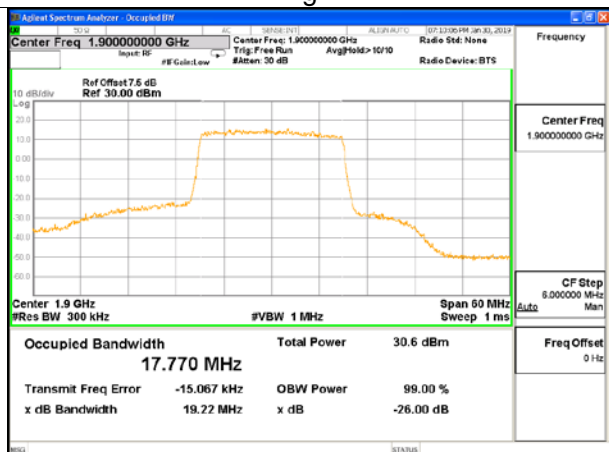

Fig.8

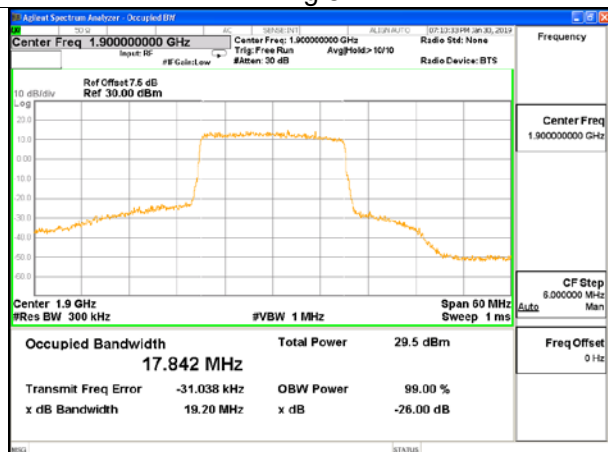
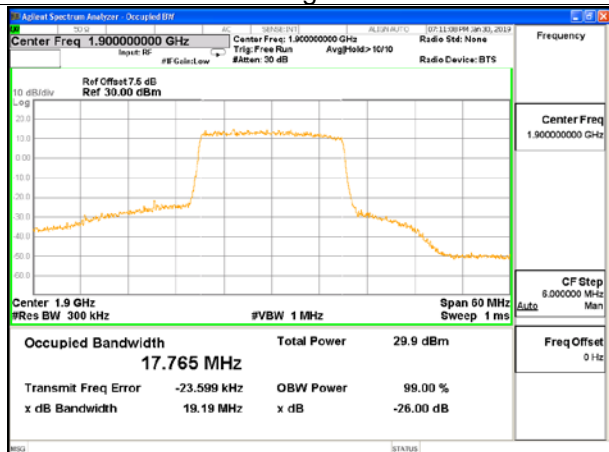
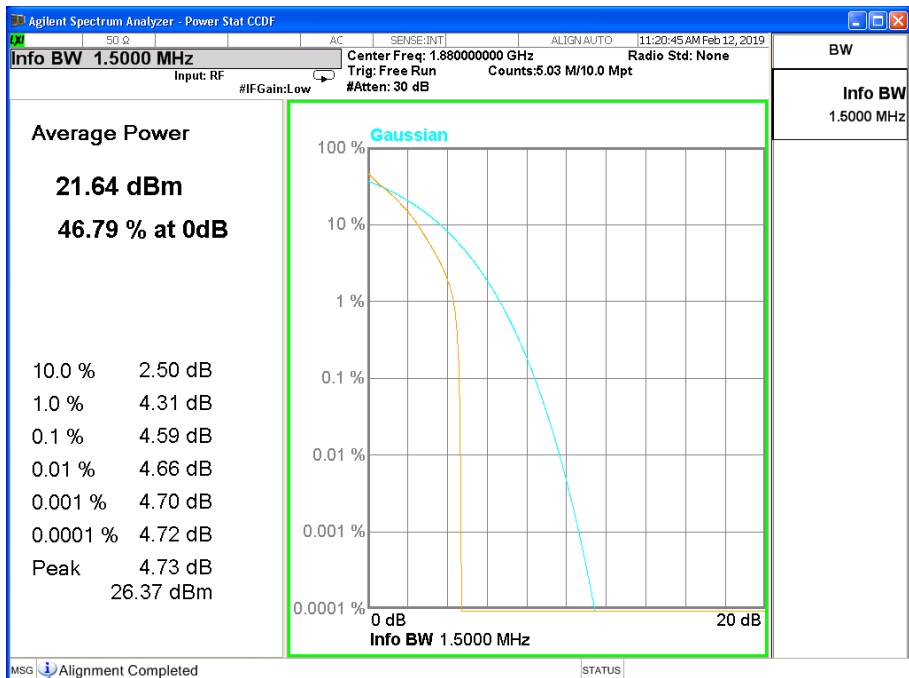

Fig.9



### 3 Peak-Average Ratio

Test result:



Peak-Average Ratio Plot(1.4MHz BW,QPSK,Band 2-mid Channel)

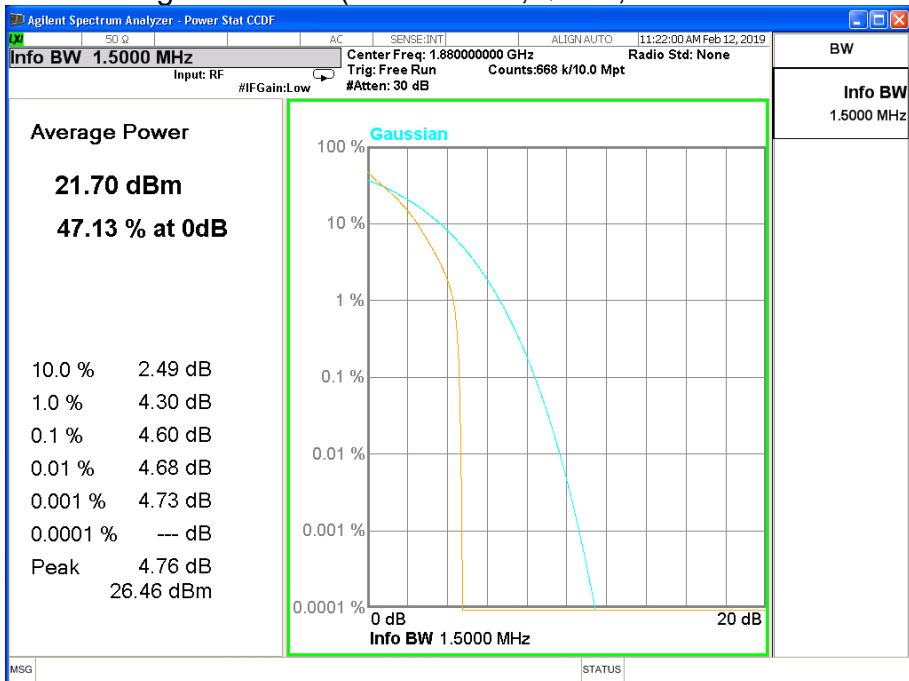

Peak-Average Ratio Plot(1.4MHz BW,16QAM,Band 2-mid Channel)

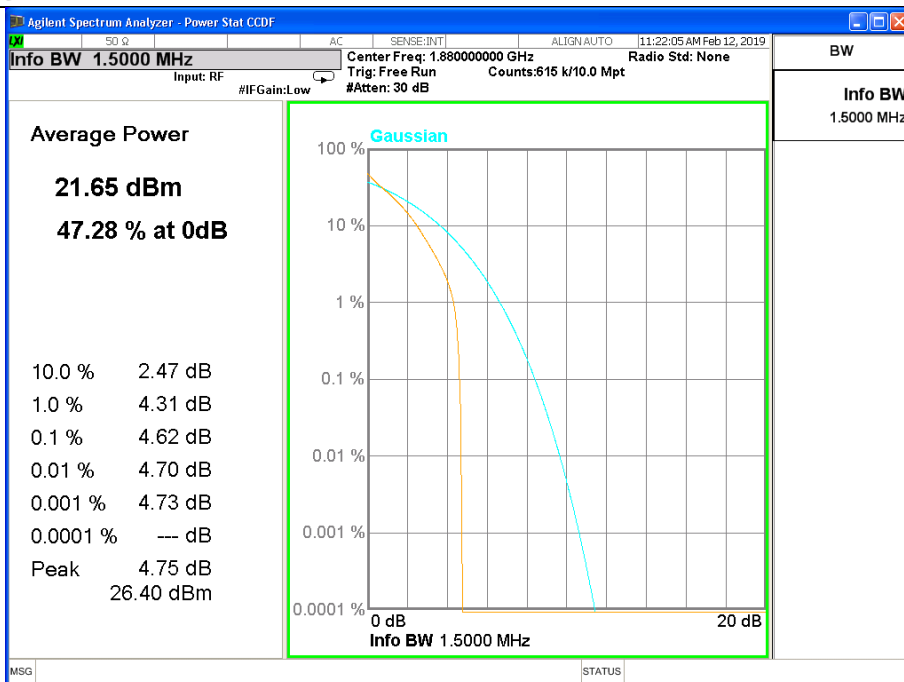

Peak-Average Ratio Plot(1.4MHz BW,64QAM,Band 2-mid Channel)

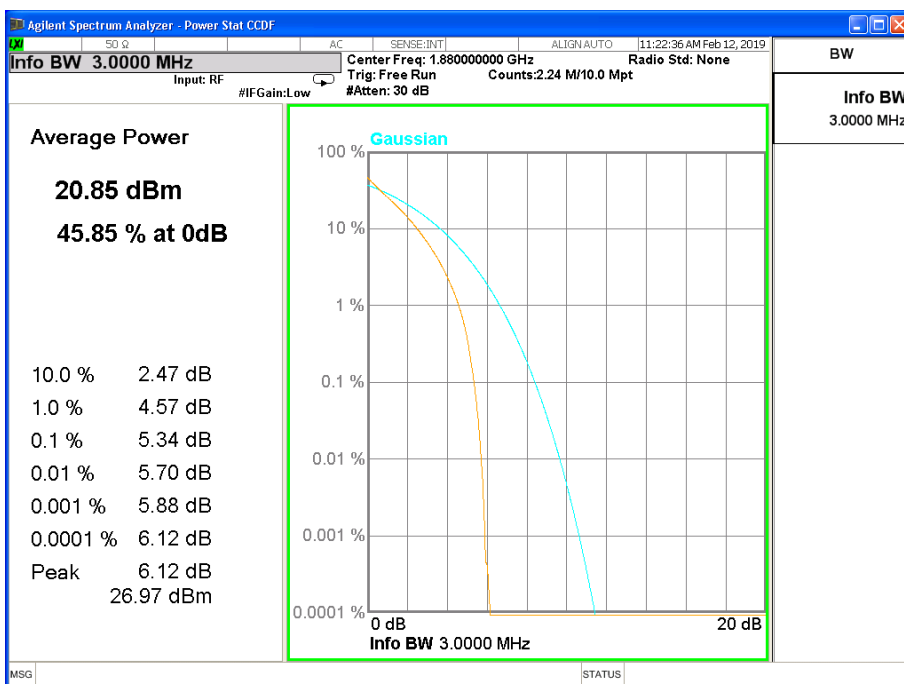

Peak-Average Ratio Plot(3MHz BW,QPSK,Band 2-mid Channel)

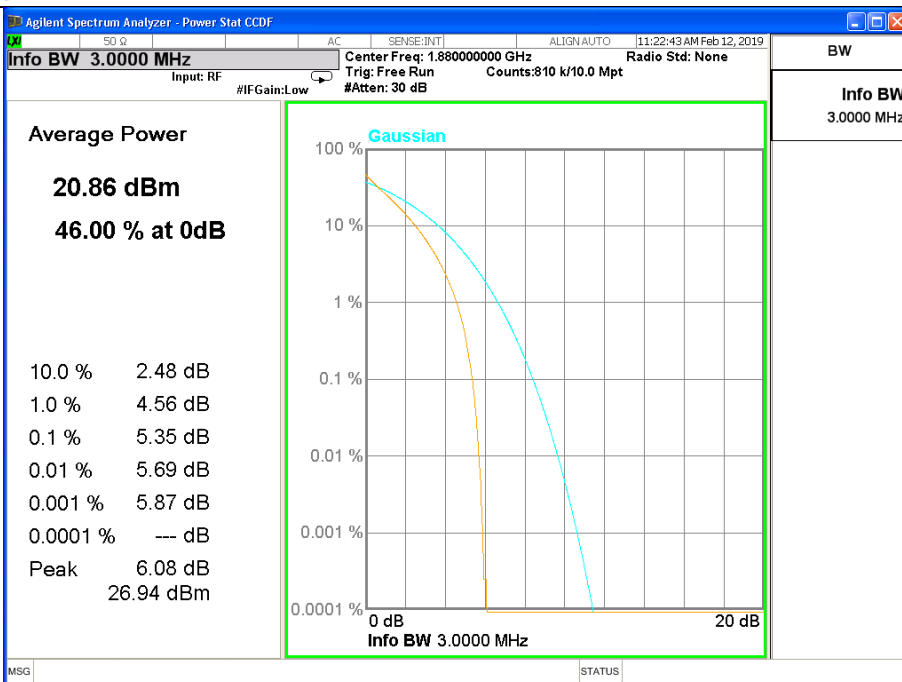

Peak-Average Ratio Plot(3MHz BW,16QAM,Band 2-mid Channel)

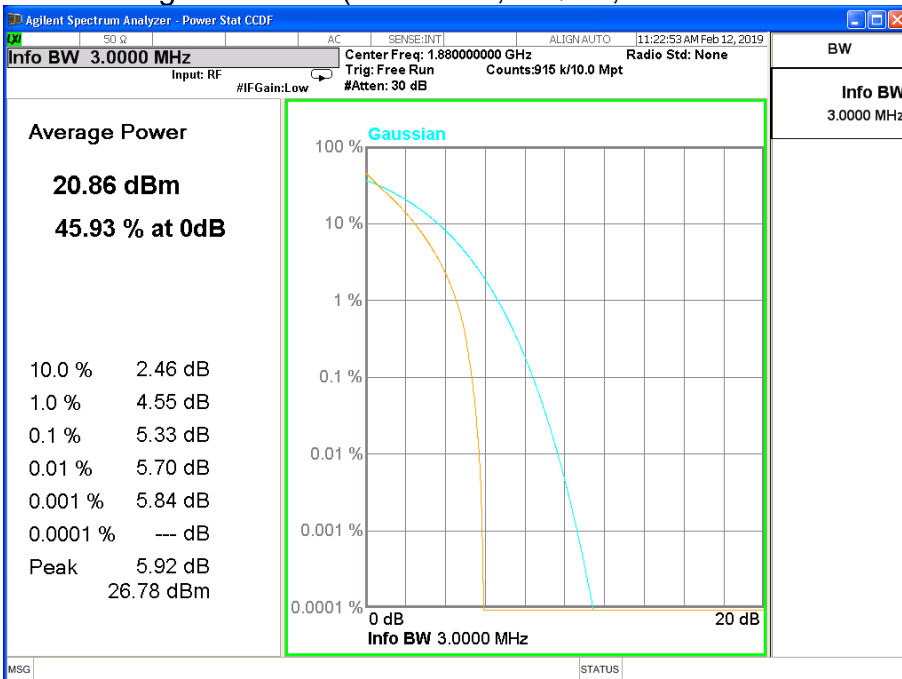

Peak-Average Ratio Plot(3MHz BW,64QAM,Band 2-mid Channel)

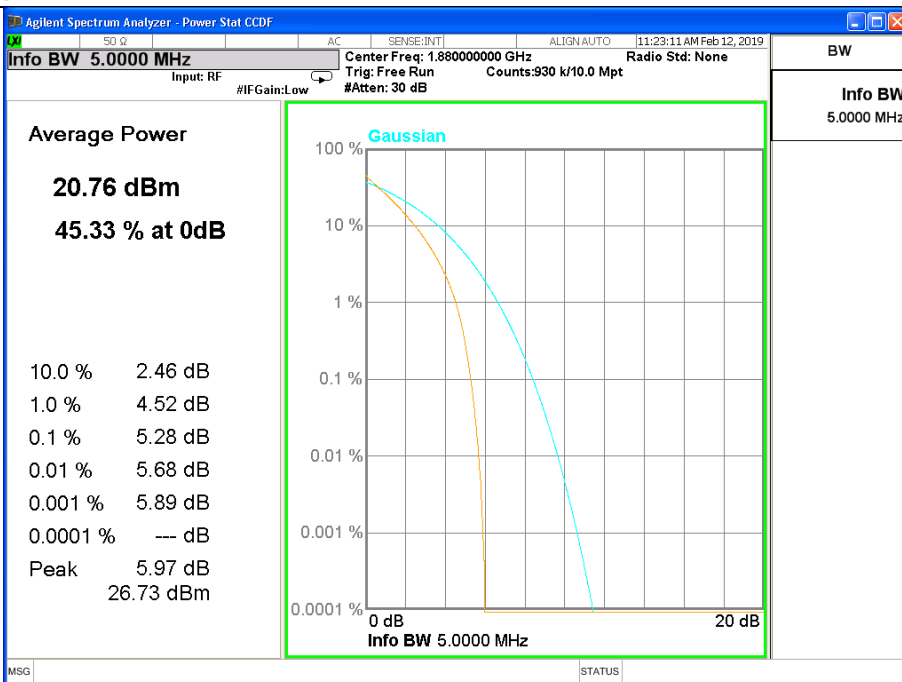

Peak-Average Ratio Plot(5MHz BW,QPSK,Band 2-mid Channel)

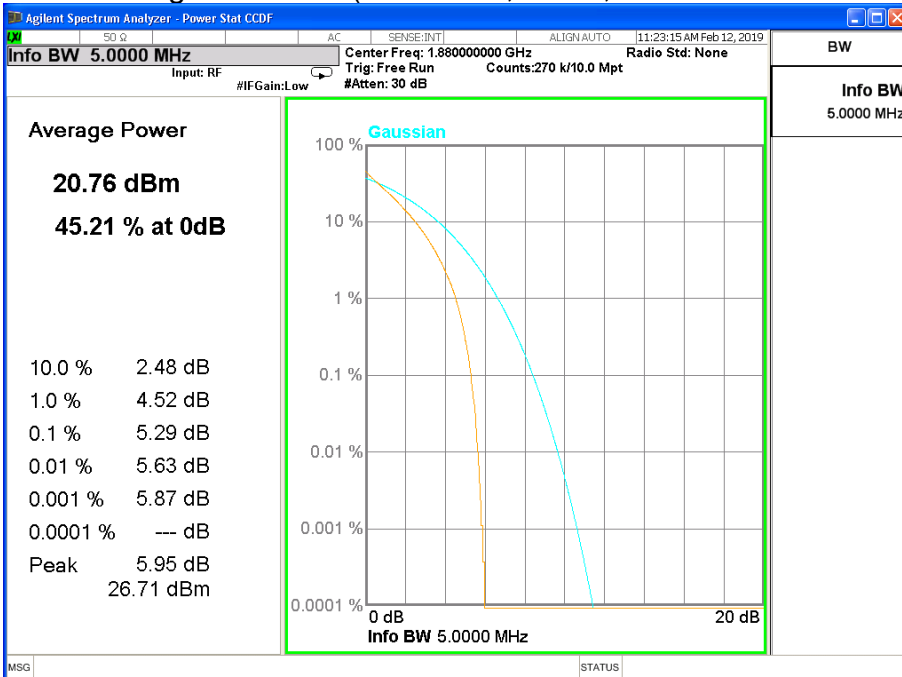

Peak-Average Ratio Plot(5MHz BW,16QAM,Band 2-mid Channel)

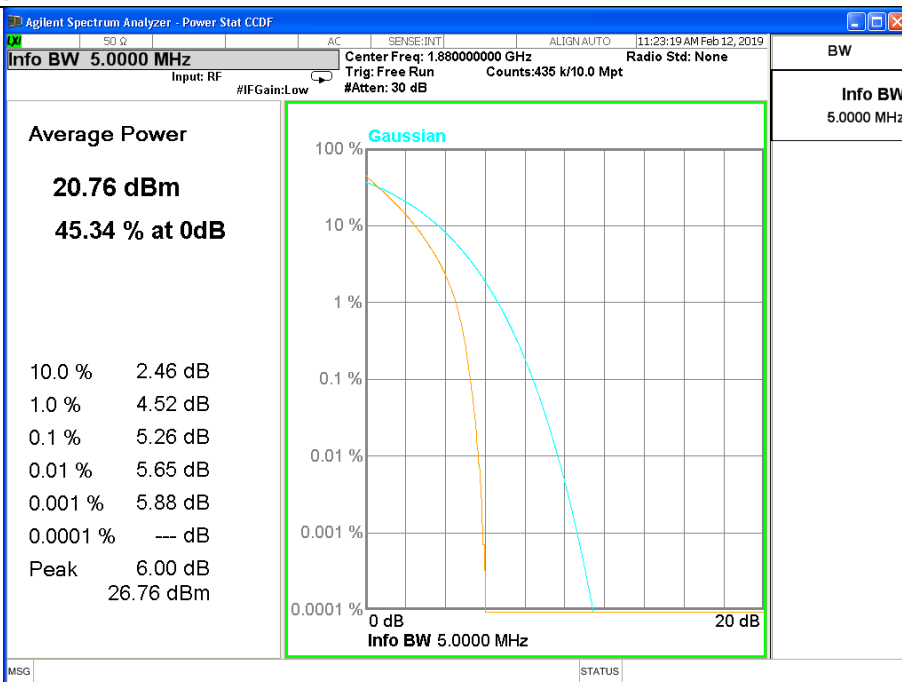

Peak-Average Ratio Plot(5MHz BW,64QAM,Band 2-mid Channel)

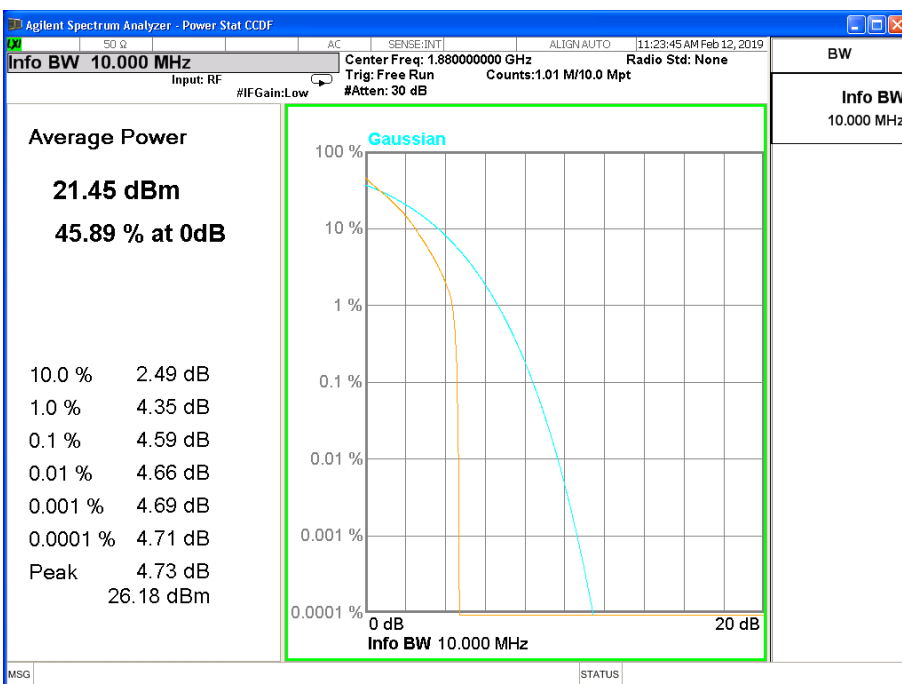

Peak-Average Ratio Plot(10MHz BW,QPSK,Band 2-mid Channel)

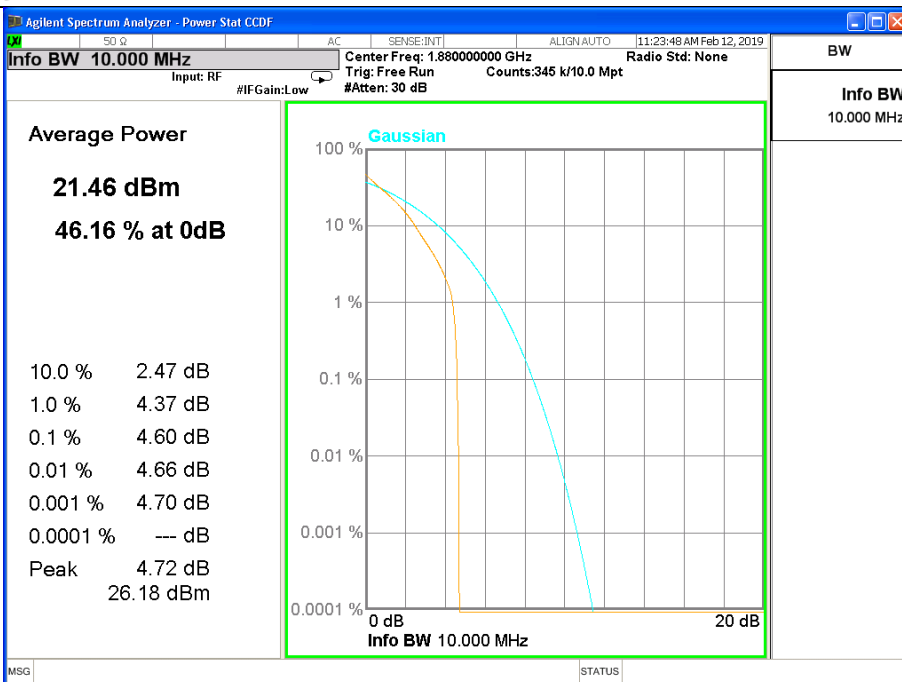

Peak-Average Ratio Plot(10MHz BW,16QAM,Band 2-mid Channel)

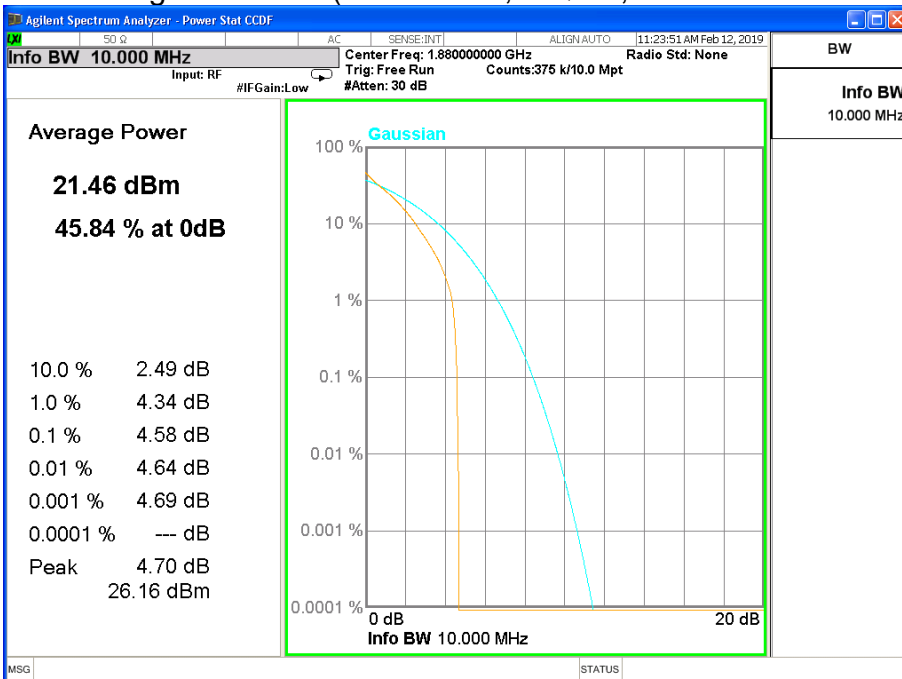

Peak-Average Ratio Plot(10MHz BW,64QAM,Band 2-mid Channel)

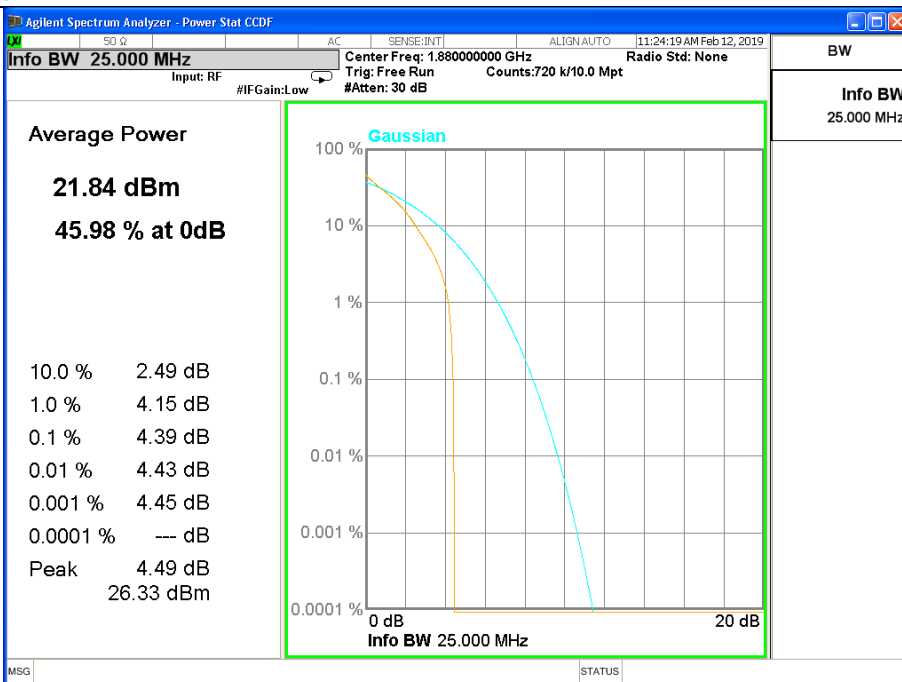

Peak-Average Ratio Plot(15MHz BW,QPSK,Band 2-mid Channel)

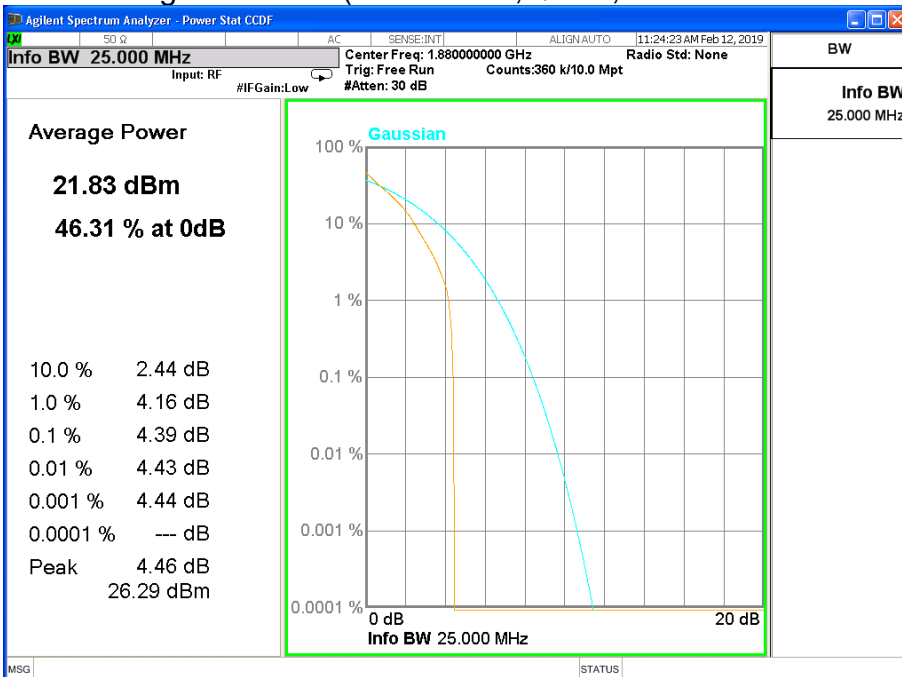

Peak-Average Ratio Plot(15MHz BW,16QAM,Band 2-mid Channel)



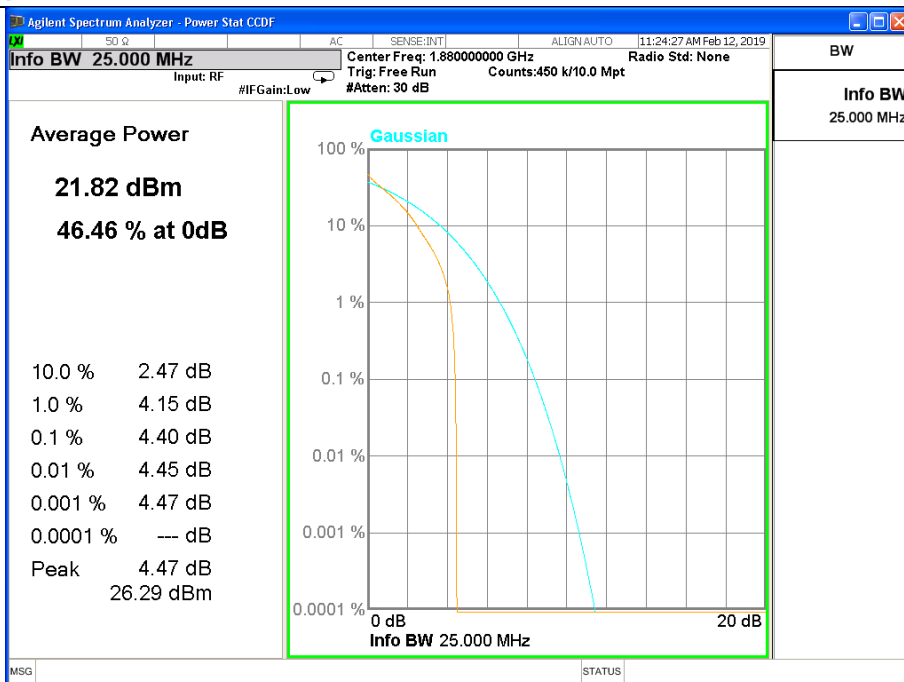

Peak-Average Ratio Plot(15MHz BW,64QAM,Band 2-mid Channel)

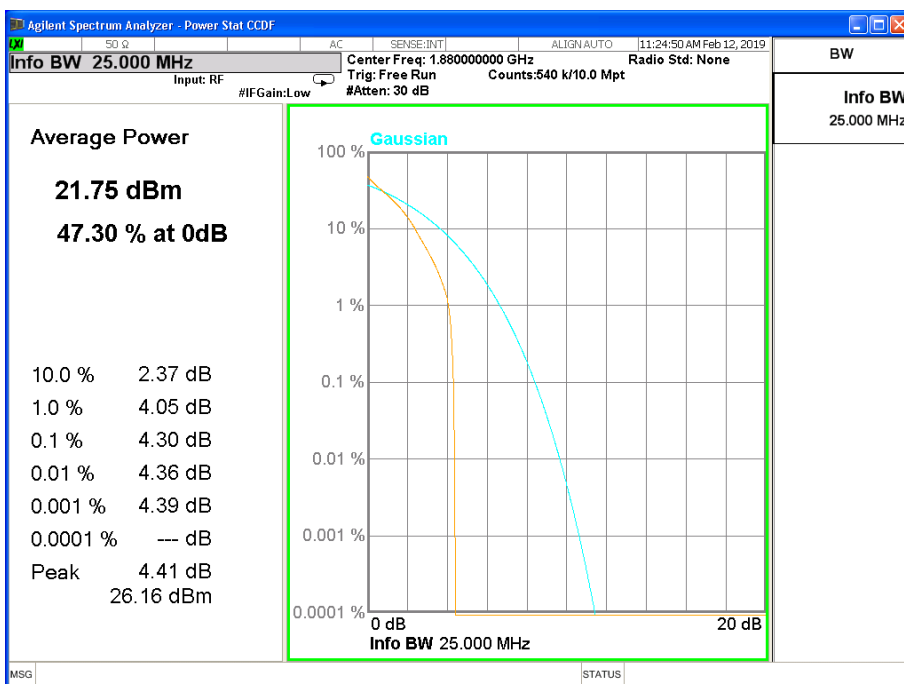

Peak-Average Ratio Plot(20MHz BW,QPSK,Band 2-mid Channel)

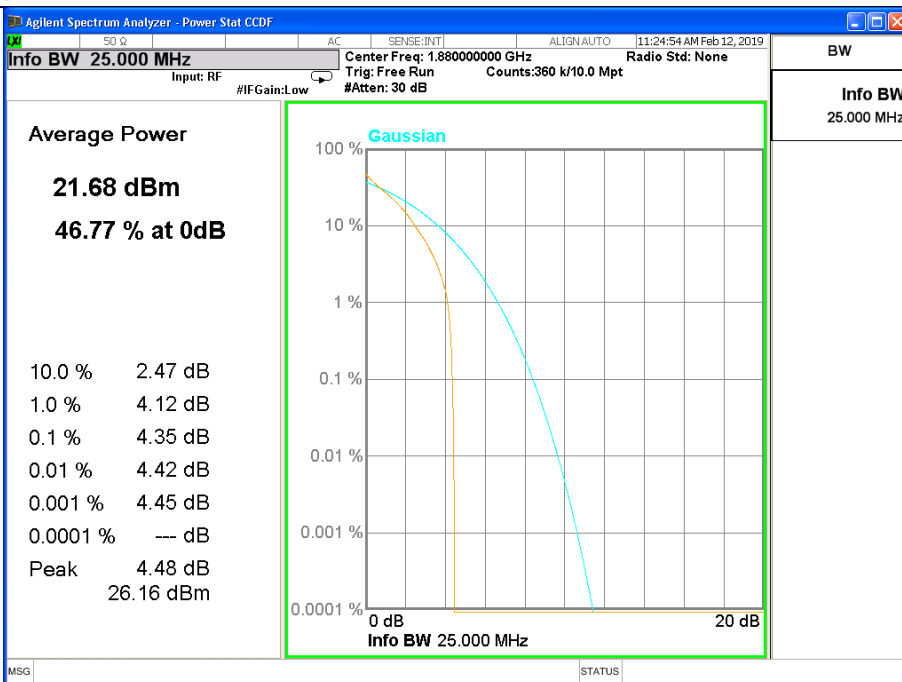

Peak-Average Ratio Plot(20MHz BW,16QAM,Band 2-mid Channel)

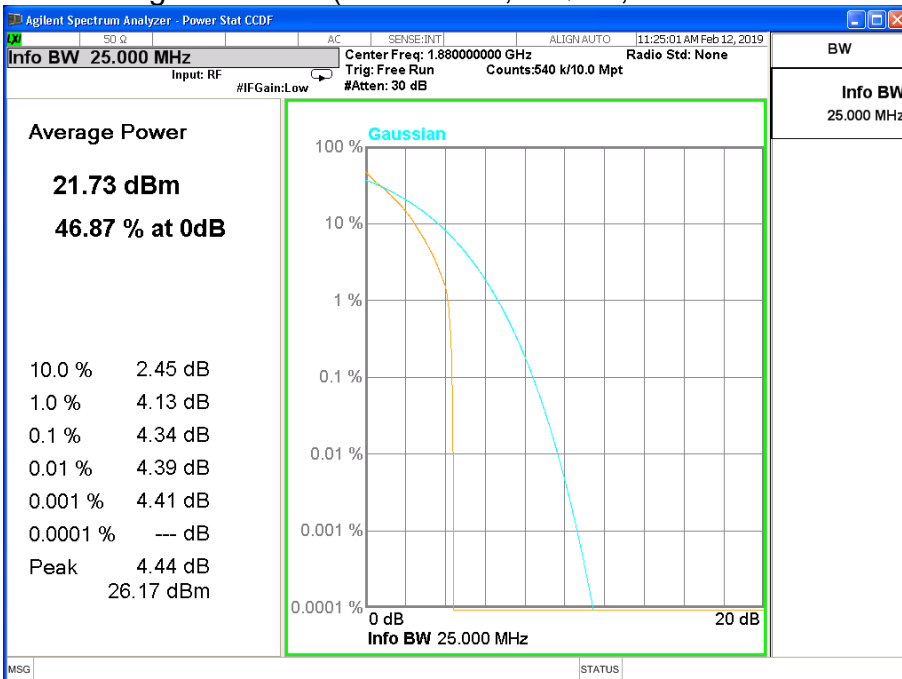

Peak-Average Ratio Plot(20MHz BW,64QAM,Band 2-mid Channel)

#### 4 Spurious Emissions at antenna terminal

Band	Carrier frequency (MHz)	Channel(Low)	BW	RB Size	RB Offset	Conducted Spurious Plot
						QPSK
2	1860	18700	20	1	0	Fig.1

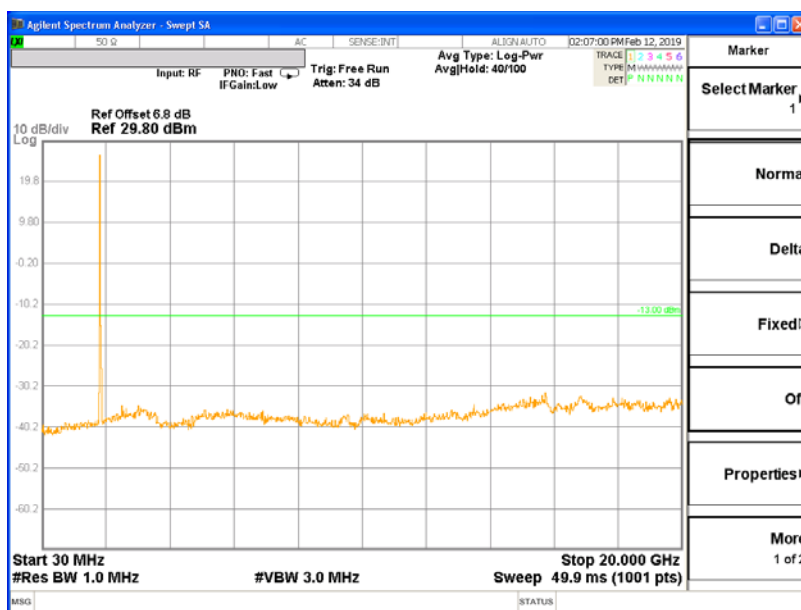

Fig.1

Band	Carrier frequency (MHz)	Channel(Low)	BW	RB Size	RB Offset	Conducted Spurious Plot
						QPSK
2	1880	18900	20	1	0	Fig.1

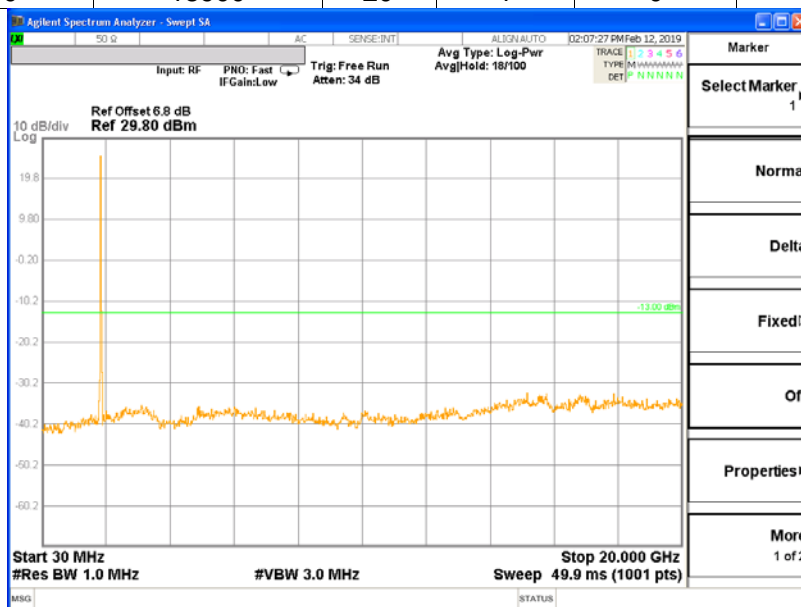

Fig.1

Band	Carrier frequency (MHz)	Channel(Low)	BW	RB Size	RB Offset	Conducted Spurious Plot
						QPSK
2	1900	19100	20	1	0	Fig.1

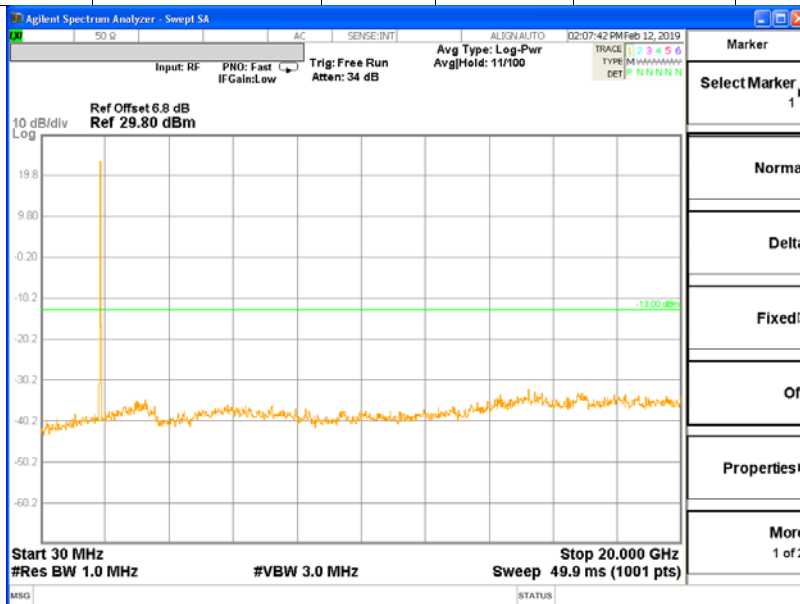

Fig.1

### 5 Band Edges Compliance

Test result

Band	Carrier frequency (MHz)	Channel (Low)	BW	RB Size	RB Offset	Band Edges Plot
						QPSK
2	1850.7	18607	1.4	1	0	Fig.1
				6	0	Fig.4

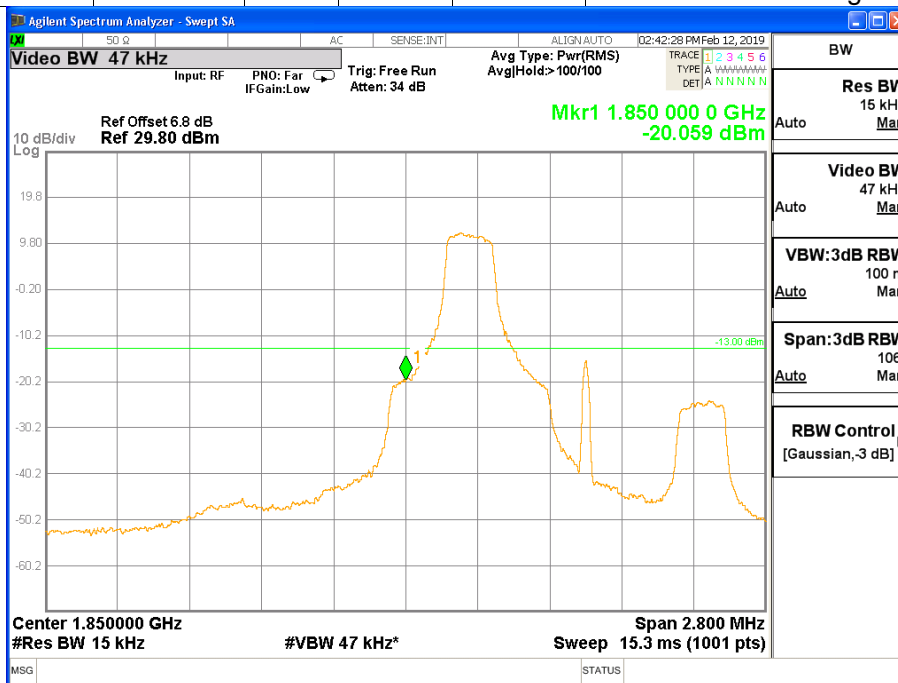

Fig.1

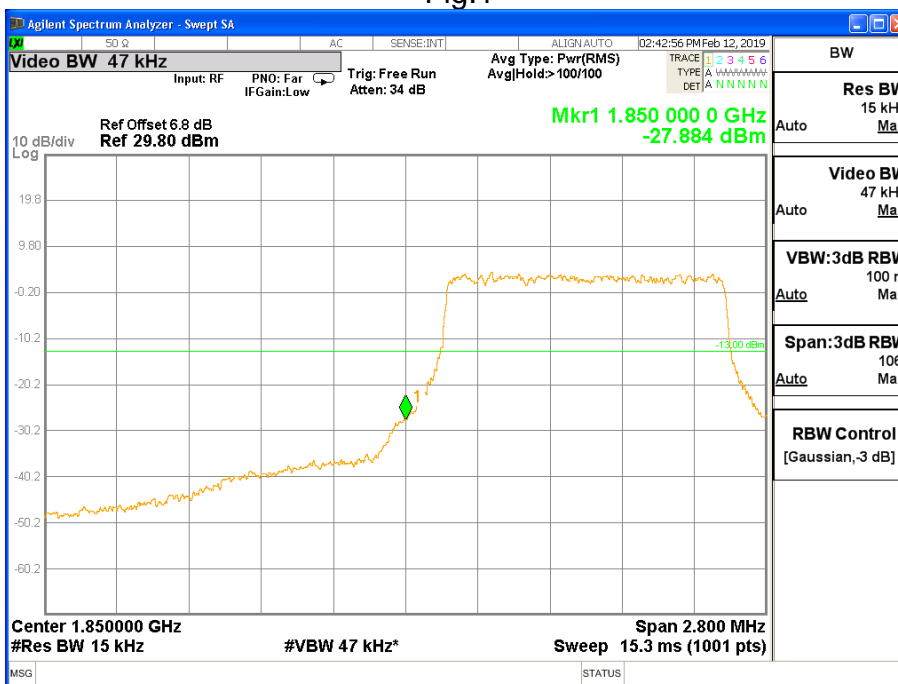

Fig.4

Band	Carrier frequency (MHz)	Channel (High)	BW	RB Size	RB Offset	Band Edges Plot
						QPSK
2	1909.3	19193	1.4	1	5	Fig.1
				6	0	Fig.4

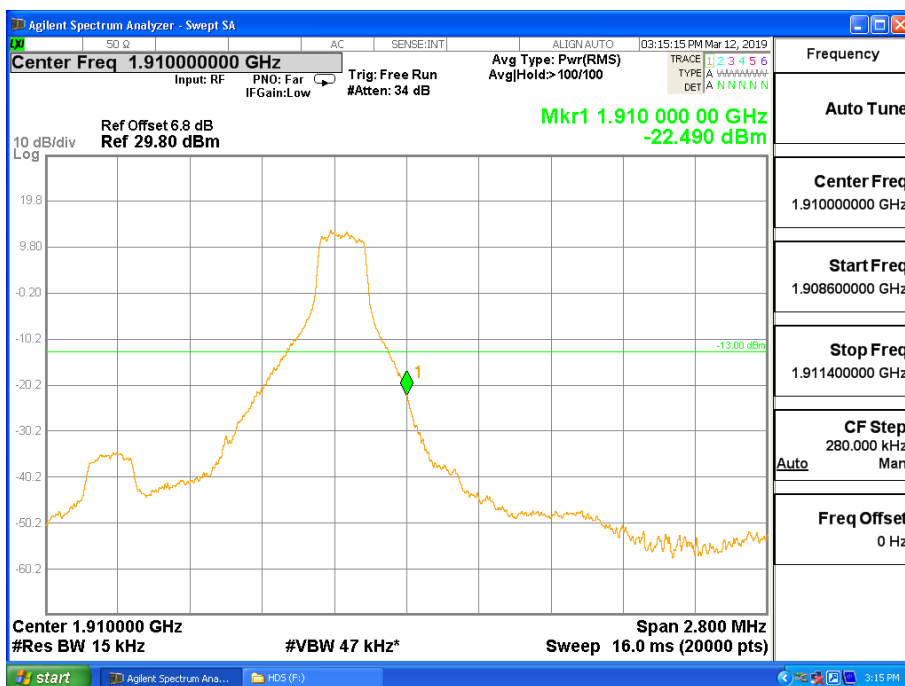

Fig.1

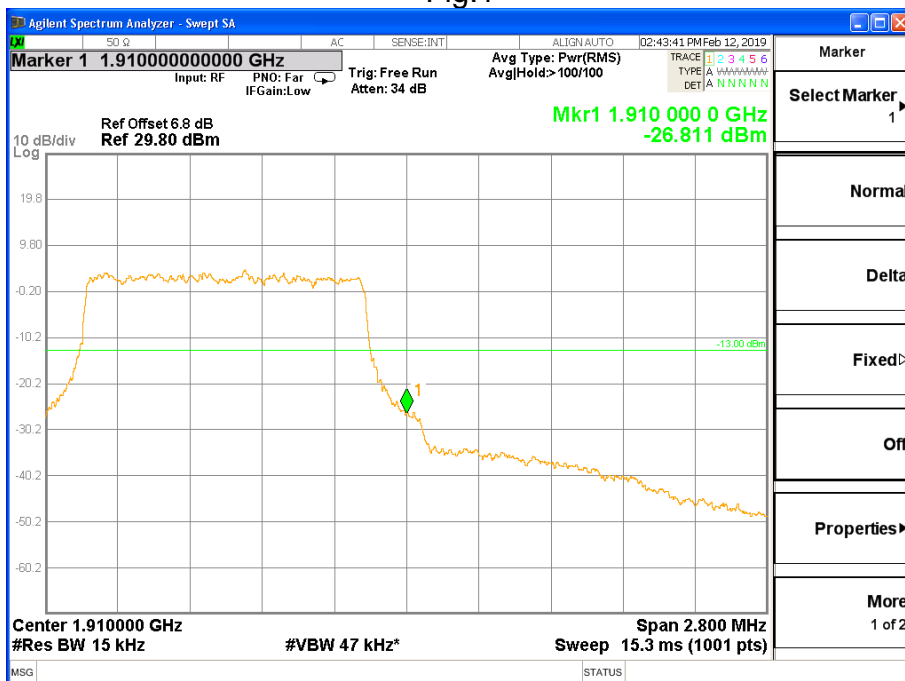

Fig.4

Band	Carrier frequency (MHz)	Channel (Low)	BW	RB Size	RB Offset	Band Edges Plot
						QPSK
2	1851.5	18615	3	1	0	Fig.1
				15	0	Fig.4

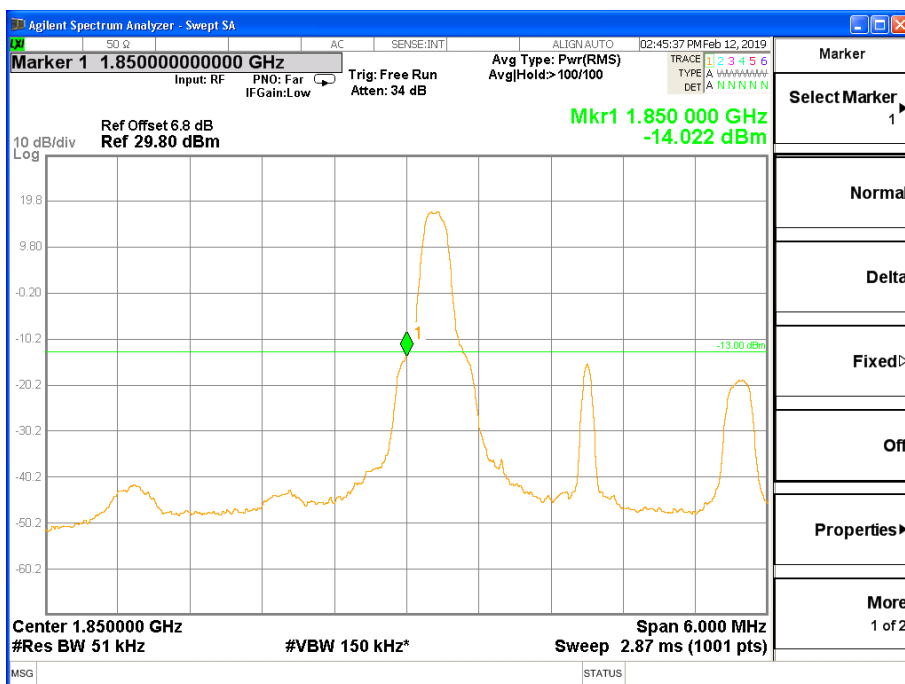

Fig.1

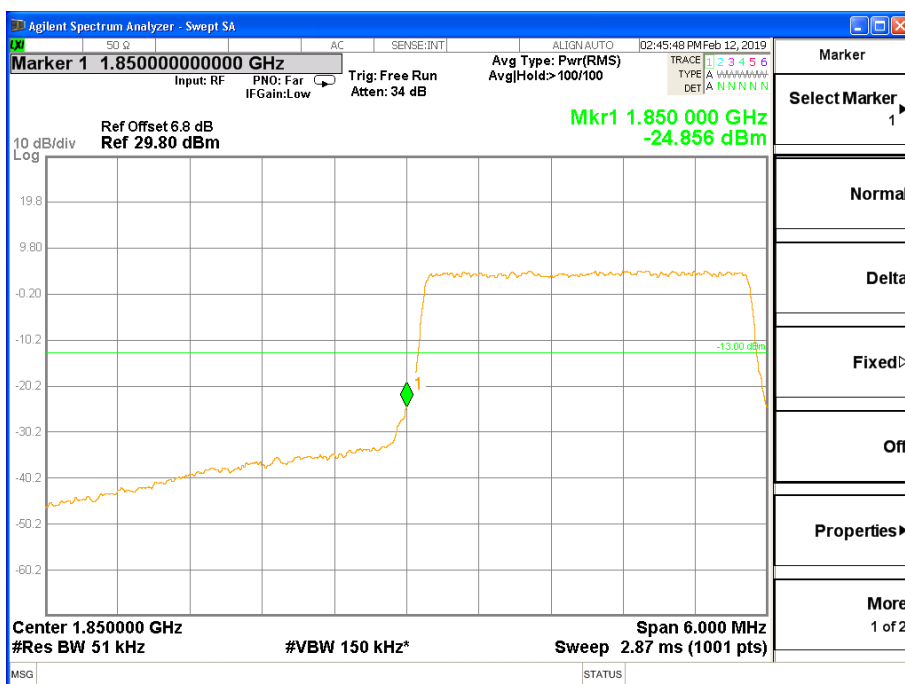

Fig.4

Band	Carrier frequency (MHz)	Channel (High)	BW	RB Size	RB Offset	Band Edges Plot
						QPSK
2	1908.5	19185	3	1	14	Fig.1
				15	0	Fig.4

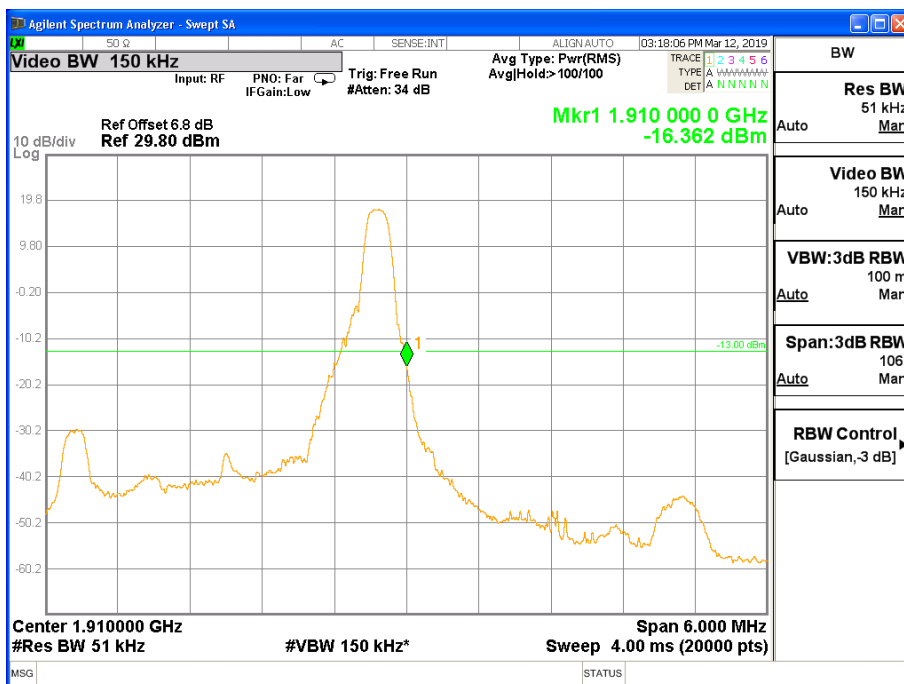

Fig.1

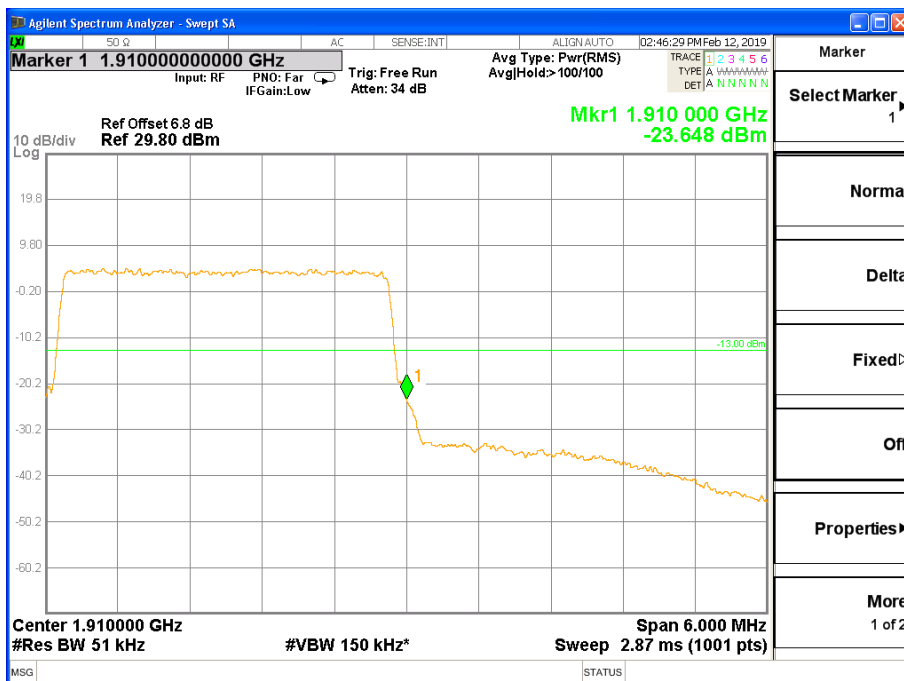

Fig.4



Band	Carrier frequency (MHz)	Channel (Low)	BW	RB Size	RB Offset	Band Edges Plot
						QPSK
2	1852.5	18625	5	1	0	Fig.1
				25	0	Fig.4

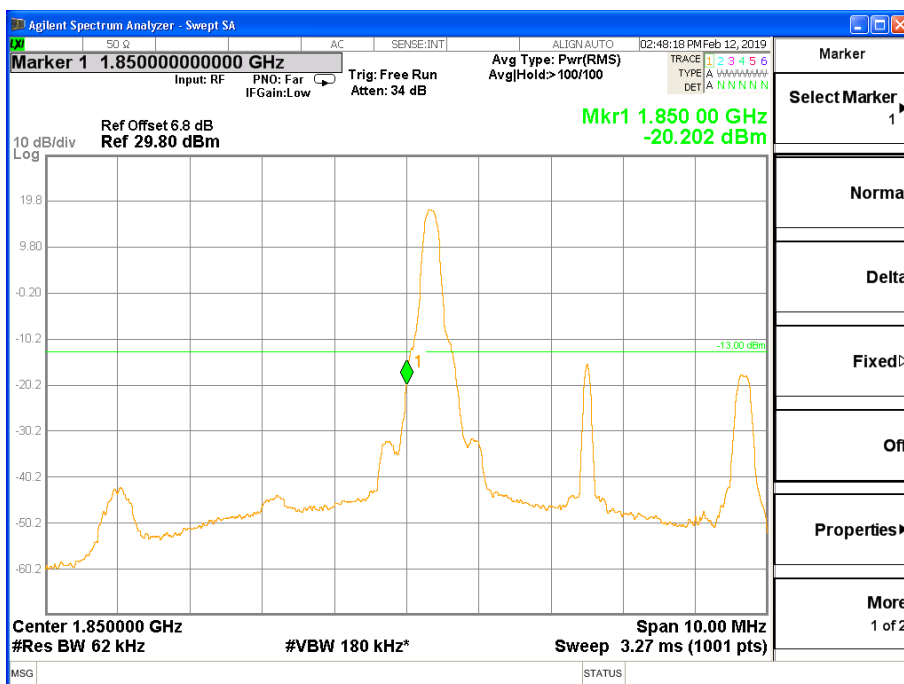

Fig.1

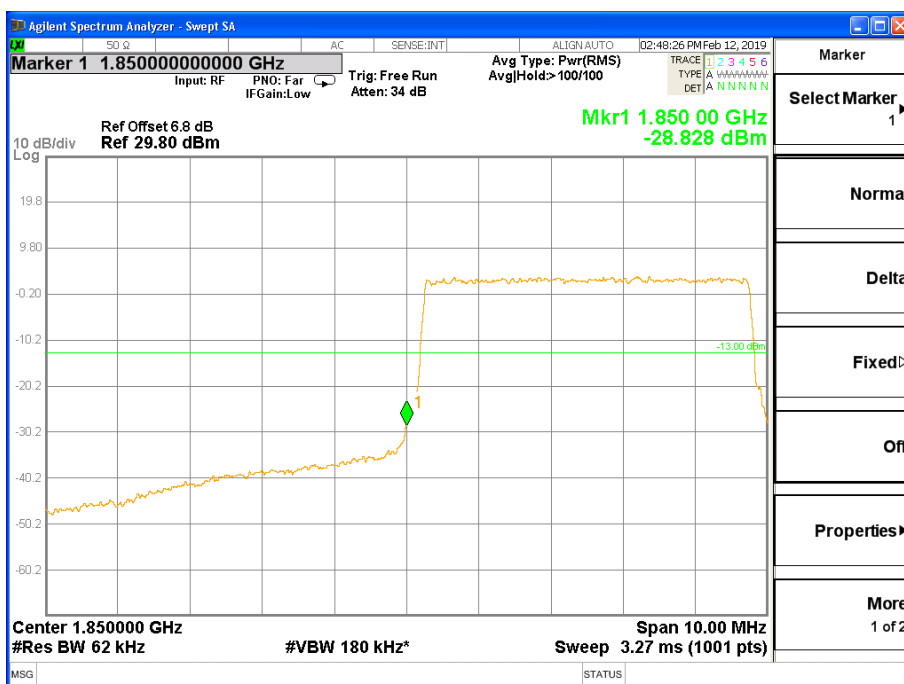

Fig.4

Band	Carrier frequency (MHz)	Channel (High)	BW	RB Size	RB Offset	Band Edges Plot
						QPSK
2	1907.5	19175	5	1	24	Fig.1
				25	0	Fig.4

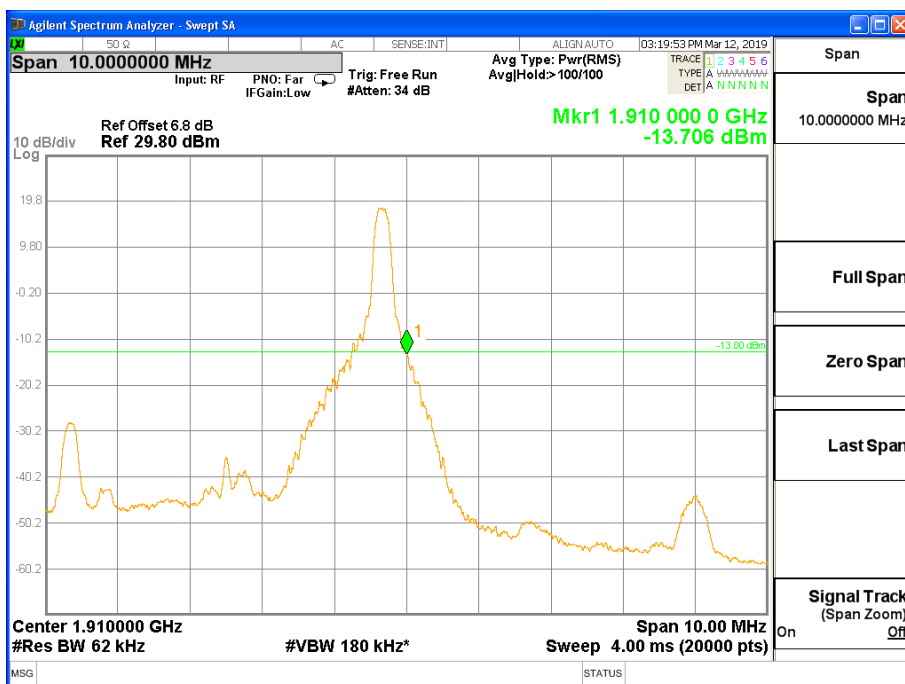

Fig.1

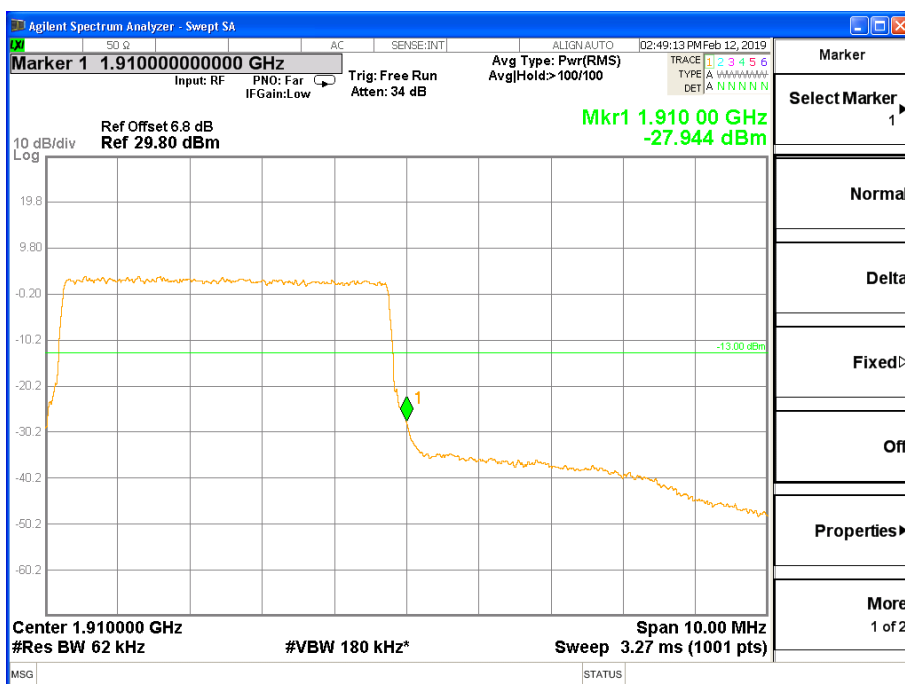

Fig.4