



TEST REPORT

Report Number: 14272097-E1V4

Applicant : ENERGOUS CORPORATION
3590 NORTH FIRST STREET,
SUITE 210,
SAN JOSE, CA 95134, U.S.A.

Model : VN-1820

FCC ID : 2ADNG-VN1820

EUT Description : WIRELESS CHARGER

Test Standard(s) : FCC CFR 47 PART 18 SUBPART C

Date Of Issue:

June 20, 2022

Prepared by:

UL Verification Services Inc.
47173 Benicia Street
Fremont, CA 94538, U.S.A.
TEL: (510) 319-4000
FAX: (510) 661-0888



REPORT REVISION HISTORY

Rev.	Issue Date	Revisions	Revised By
V1	5/27/2022	Initial Issue	--
V2	6/14/2022	Updated Section 5.3, 7.2.3 and 7.3.3	Kiya Kedida
V3	6/17/2022	Updated Section 7.2.3 and 7.3.3	Kiya Kedida
V4	6/20/2022	Updated page 10. Added FCC15.209 limit on page 14. Added statement on page 29, 30, 38	Tina Chu

TABLE OF CONTENTS

REPORT REVISION HISTORY	2
TABLE OF CONTENTS	3
1. ATTESTATION OF TEST RESULTS	5
2. TEST METHODOLOGY	7
3. FACILITIES AND ACCREDITATION	7
4. DECISION RULES AND MEASUREMENT UNCERTAINTY	8
4.1. METROLOGICAL TRACEABILITY	8
4.2. DECISION RULES.....	8
4.3. MEASUREMENT UNCERTAINTY.....	8
4.4. SAMPLE CALCULATION	8
5. EQUIPMENT UNDER TEST	9
5.1. EUT DESCRIPTION	9
5.2. OPERATING FREQUENCY AND POWER.....	9
5.3. DESCRIPTION OF AVAILABLE ANTENNAS	9
5.4. SOFTWARE AND FIRMWARE.....	9
5.5. WORST-CASE CONFIGURATION AND MODE.....	10
5.6. DESCRIPTION OF TEST SETUP.....	11
6. TEST AND MEASUREMENT EQUIPMENT	13
7. RADIATED EMISSIONS.....	14
7.1. SPURIOUS EMISSIONS 9 kHz TO 30 MHz	16
7.1.1. CONFIGURATION 1.....	16
7.1.2. CONFIGURATION 2 Part 18 Limit.....	17
7.1.3. CONFIGURATION 2 Part 15.209 Limit	18
7.2. SPURIOUS EMISSIONS 30 MHz TO 1000 MHz	19
7.2.1. CONFIGURATION 1.....	19
7.2.2. CONFIGURATION 2 FCC Part 18 Limit.....	21
7.2.3. CONFIGURATION 2 FCC Part 15.209 Limit	26
7.3. SPURIOUS EMISSIONS 1 GHz TO 10 GHz.....	31
7.3.1. CONFIGURATION 1.....	31
7.3.2. CONFIGURATION 2 FCC Part 18 Limit.....	33
7.3.3. CONFIGURATION 2 FCC Part 15.209 Limit	37
8. AC POWER LINE CONDUCTED EMISSIONS	41
8.1. CONFIGURATION 1.....	42

8.2. CONFIGURATION 2.....	44
9. SETUP PHOTOS.....	46
9.1. CONFIGURATION 1.....	46
9.2. CONFIGURATION 2.....	48

1. ATTESTATION OF TEST RESULTS

COMPANY NAME: ENERGOUS CORPORATION
3590 NORTH FIRST STREET,
SUITE 210,
SAN JOSE, CA 95134, U.S.A

EUT DESCRIPTION: WIRELESS CHARGER

MODEL NUMBER: VN-1820

BRAND: ENERGOUS

SERIAL NUMBER: 3013

SAMPLE RECEIPT DATE: MAY 09, 2022

DATE TESTED: MAY 09, 2022– MAY 12, 2022

APPLICABLE STANDARDS	
STANDARD	TEST RESULTS
FCC CFR 47 PART 18 SUBPART C	Complies

UL Verification Services Inc. tested the above equipment in accordance with the requirements set forth in the above standards. The test results show that the equipment tested is capable of demonstrating compliance with the requirements as documented in this report.

The results documented in this report apply only to the tested sample, under the conditions and modes of operation as described herein. It is the manufacturer's responsibility to assure that additional production units of this model are manufactured with identical electrical and mechanical components. All samples tested were in good operating condition throughout the entire test program. Measurement Uncertainties are published for informational purposes only and were not taken into account unless noted otherwise.

This document may not be altered or revised in any way unless done so by UL Verification Services Inc. and all revisions are duly noted in the revisions section. Any alteration of this document not carried out by UL Verification Services Inc. will constitute fraud and shall nullify the document. This report must not be used by the client to claim product certification, approval, or endorsement by A2LA, NIST, any agency of the Federal Government, or any agency of the U.S. government.

Approved & Released For
UL Verification Services Inc. By:



DAN CORONIA
OPERATIONS LEADER
UL Verification Services Inc.

Prepared By:

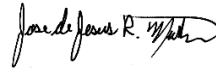

JOSE MARTINEZ
TEST ENGINEER
UL Verification Services Inc.

Reviewed By:

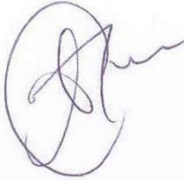

TINA CHU
SENIOR PROJECT ENGINEER
UL Verification Services Inc.

2. TEST METHODOLOGY

This report contains data provided by the customer which can impact the validity of results. UL Verification Services Inc. is only responsible for the validity of results after the integration of the data provided by the customer.

The tests documented in this report were performed in accordance with FCC / OST MP-5, "FCC Methods of Measurements of Radio Noise Emissions from Industrial, Scientific, and Medical Equipment."

3. FACILITIES AND ACCREDITATION

UL Verification Services Inc. is accredited by A2LA, Certificate Number #0751.05, for all testing performed within the scope of this report. Testing was performed at the locations noted below.

	Address	ISED CABID	ISED Company Number	FCC Registration
<input type="checkbox"/>	Building 1: 47173 Benicia Street, Fremont, CA 94538, USA	US0104	2324A	550739
<input type="checkbox"/>	Building 2: 47266 Benicia Street, Fremont, CA 94538, USA	US0104	22541	550739
<input checked="" type="checkbox"/>	Building 4: 47658 Kato Rd, Fremont, CA 94538, USA	US0104	2324B	550739

4. DECISION RULES AND MEASUREMENT UNCERTAINTY

4.1. METROLOGICAL TRACEABILITY

All test and measuring equipment utilized to perform the tests documented in this report are calibrated on a regular basis, with a maximum time between calibrations of one year or the manufacturers' recommendation, whichever is less, and where applicable is traceable to recognized national standards.

4.2. DECISION RULES

The Decision Rule is based on Simple Acceptance in accordance with ISO Guide 98-4:2012 Clause 8.2. (Measurement uncertainty is not taken into account when stating conformity with a specified requirement.)

4.3. MEASUREMENT UNCERTAINTY

Where relevant, the following measurement uncertainty levels have been estimated for tests performed on the apparatus:

PARAMETER	U _{Lab}
Worst Case Conducted Disturbance, 9KHz to 0.15 MHz	3.78 dB
Worst Case Conducted Disturbance, 0.15 to 30 MHz	3.40 dB
Worst Case Radiated Disturbance, 9KHz to 30 MHz	2.84 dB
Worst Case Radiated Disturbance, 30 to 1000 MHz	6.01 dB
Worst Case Radiated Disturbance, 1000 to 18000 MHz	4.73 dB
Worst Case Radiated Disturbance, 18000 to 26000 MHz	4.51 dB
Worst Case Radiated Disturbance, 26000 to 40000 MHz	5.29 dB

Uncertainty figures are valid to a confidence level of 95%.

4.4. SAMPLE CALCULATION

RADIATED EMISSIONS

Where relevant, the following sample calculation is provided:

$$\text{Field Strength (dBuV/m)} = \text{Measured Voltage (dBuV)} + \text{Antenna Factor (dB/m)} + \text{Cable Loss (dB)} - \text{Preamp Gain (dB)}$$

$$36.5 \text{ dBuV} + 18.7 \text{ dB/m} + 0.6 \text{ dB} - 26.9 \text{ dB} = 28.9 \text{ dBuV/m}$$

MAINS CONDUCTED EMISSIONS

Where relevant, the following sample calculation is provided:

$$\text{Final Voltage (dBuV)} = \text{Measured Voltage (dBuV)} + \text{Cable Loss (dB)} + \text{Limiter Factor (dB)} + \text{LISN Insertion Loss.}$$

$$36.5 \text{ dBuV} + 0 \text{ dB} + 10.1 \text{ dB} + 0 \text{ dB} = 46.6 \text{ dBuV}$$

5. EQUIPMENT UNDER TEST

5.1. EUT DESCRIPTION

The EUT is an over-the-air, distance charging transmitter. Wireless power transfer is only transmitting a continuous carrier wave signal at 917.5 MHz frequency single channel when client device is positioned within the charging zone. The EUT can only charge one client device at a time. The EUT uses BLE to pair with the client device.

This report documents test results of the Wireless Power Transfer ISM portion and ultrasonic sensor of the wireless charger.

5.2. OPERATING FREQUENCY AND POWER

The EUT operates at 917.5 MHz. And the maximum RF energy generated is 41.76dBm as declared by the applicant. The device is powered via a Power Barrel Connector Jack interface (24V / 2 Amps).

This device also includes an ultrasonic sensor operating at 175 kHz at power/energy level of less than 1mW.

5.3. DESCRIPTION OF AVAILABLE ANTENNAS

The antenna gain(s) and type, as provided by the manufacturer, are as follows:

The EUT supports one patch antenna with antenna peak gain 8dBi for the WPT 917.5 MHz frequency.

It also has a Ultrasonic proximity sensor system that disables the WPT portion of this device in order to limit RF exposure to the end user within 35cm.

5.4. SOFTWARE AND FIRMWARE

The firmware installed in the EUT during testing was Version: 5.0.1.47_2093

The test utility software was Version 1.0.36

5.5. WORST-CASE CONFIGURATION AND MODE

The EUT is a tabletop device and it has two ports, one is the power barrel connector jack for power only, second port is a micro USB port for command line interface control, end user will not have access to it. Therefore, all final radiated testing was performed with the EUT in tabletop orientation powered by AC/DC adapter via cable.

The worst case orientation and position of the client device was investigated and declared by the applicant. The applicant determined that the operating condition for worst-case emissions is when the charger is operating at the maximum rated level and the maximum possible power (as adjusted by internal power control circuitry) is coupled to the client device. This condition occurs at the following orientation and position: the client device is lifted up 3cm by using a styrofoam block and directly centered on the tabletop, 35cm in front of the EUT with a flatbed orientation where right side of the client is directly pointing at the EUT. All of the charging mode final testing is performed using this configuration of charger and client.

The radiated emissions recorded for test configuration 2 (charging mode) are compared to both the Part 18 and the Part 15.209 radiated emissions limits. The use of the radiated emissions limits of 15.209 is for information purposes only. The data is to support manufacturer request for consideration of "distance charging" at distances of greater than 1m under the latest draft KDB 680106 where spurious emissions at 3m from the outside of the building where the charger is installed need to be considered.

The antenna is active for all the charging mode testing.

Configuration	Mode	Description
1	Standby mode	EUT is powered by AC/DC adapter via cable. Wireless Power Transfer ISM portion is in standby mode, ultrasonic sensor is on. Ultrasonic sensor and BLE are in normal operating mode as the worst case.
2	Charging mode	EUT is powered by AC/DC adapter via cable and client device receives maximum 917.5 MHz RF energy from EUT, ultrasonic sensor is off. Wireless Power Transfer ISM portion and BLE can transmit simultaneously. BLE is in normal operating mode as the worst case.

5.6. DESCRIPTION OF TEST SETUP

SUPPORT TEST EQUIPMENT						
Description	Manufacturer	Model	Serial Number	FCC ID/ DoC		
1 Receiver (client device)	Energous	-	PER300F	DoC		
EUT AC/DC Adapter (50 W)	XP Power	VEC50US24	E20122202-4M-0011-2105	DoC		
I/O CABLES (RF RADIATED/AC POWER LINE TEST)						
Cable No.	Port	# of Identical Ports	Connector Type	Cable Type	Cable Length (m)	Remarks
1	AC	1	AC	Un-shielded	1.8	AC Mains to AC/DC Adapter
2	DC	1	Power Barrel Connector Jack	Un-shielded	1.5	AC/DC Adapter to EUT

TEST SETUP- RADIATED TEST/AC POWER LINE TEST

The EUT is powered by AC/DC adapter via cable, the client device is lifted up 3cm by using a styrofoam block and directly centered on the tabletop, 35cm in front of the EUT with a flatbed orientation where right side of the client is directly pointing at the EUT.

SETUP DIAGRAM

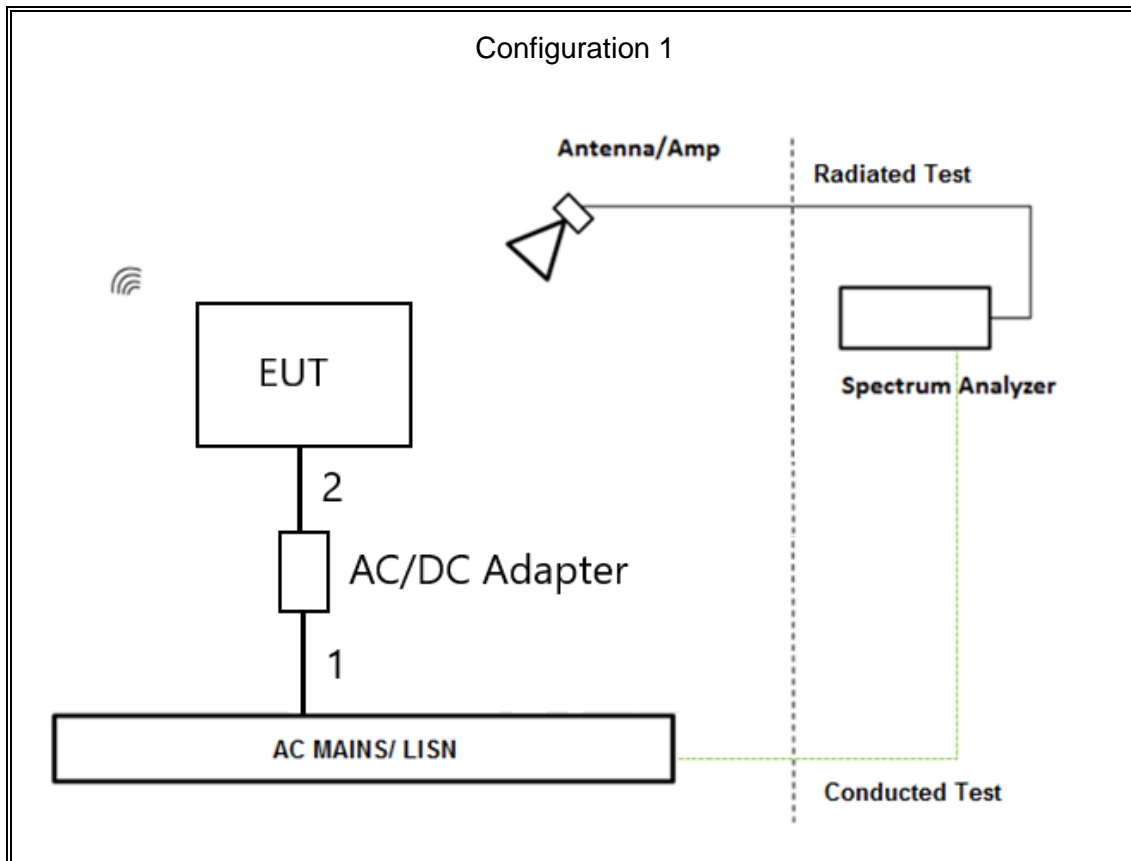

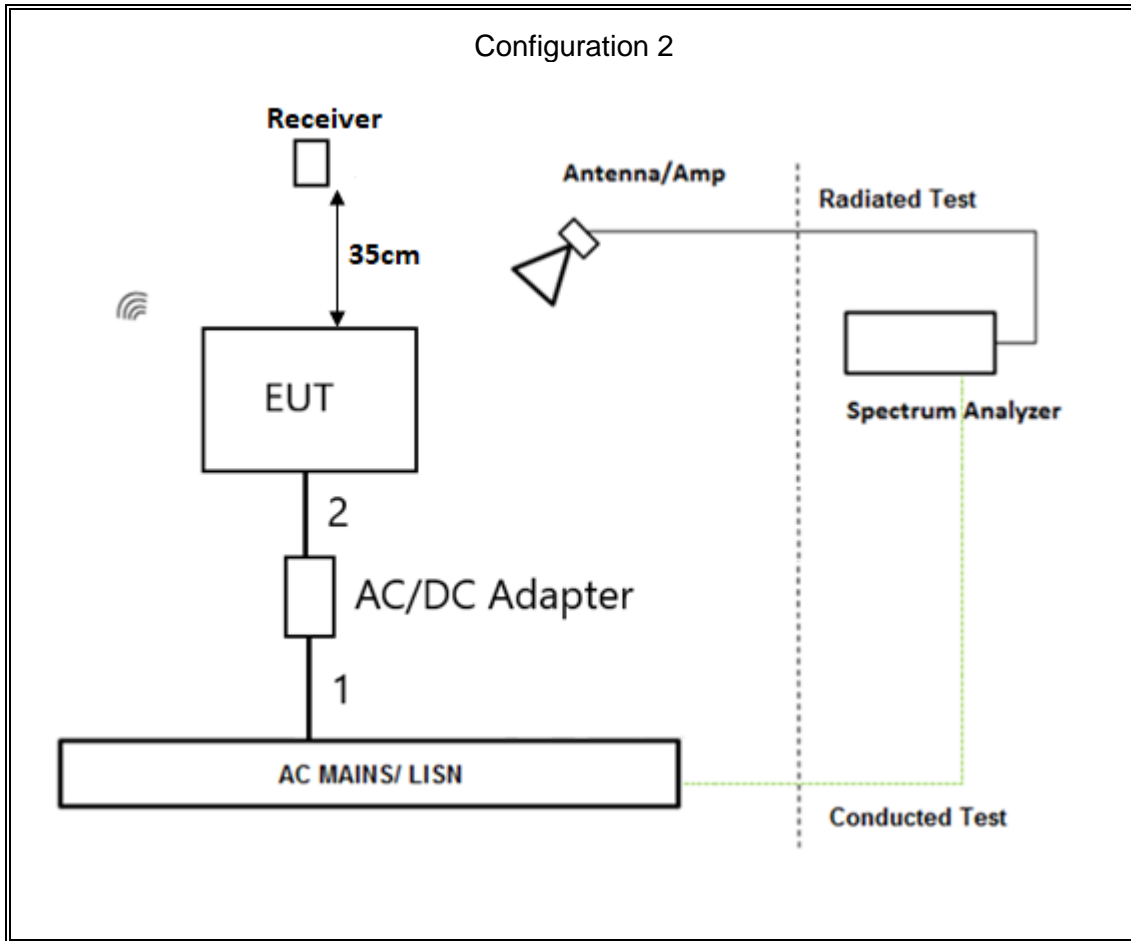

6. TEST AND MEASUREMENT EQUIPMENT

The following test and measurement equipment was utilized for the tests documented in this report:

TEST EQUIPMENT LIST				
Description	Manufacturer	Model	Asset	Cal Due
Antenna, Passive Loop 30Hz - 1MHz	ELECTRO METRICS	EM-6871	SC-8015	05/24/2022
Antenna, Passive Loop 100KHz - 30MHz	ELECTRO METRICS	EM-6872	SC-8014	05/24/2022
Antenna, Horn 1-18GHz	ETS-Lindgren	3117	80404	08/04/2022
RF Filter Box, 8 port, 1-18GHz	UL-FR1 (CTECH)	SAC 8 port rf box 1	197920	04/19/2023
Antenna, Broadband Hybrid, 30MHz to 2GHz	Sunol Sciences Corp.	JB1	82258	10/01/2022
Amplifier, 9KHz to 1GHz, 32dB	SONOMA INSTRUMENT	310	175953	02/08/2023
EMI TEST RECEIVER	Rohde & Schwarz	ESW44	169927	02/16/2023
Filter, BRF 902 to 928MHz	MICRO-TRONICS	BRC50722	156484	05/06/2023
Filter, HPF 1.5 to 18GHz	MICRO-TRONICS	HPM50114	204786	06/24/2022
AC Line Conducted				
Description	Manufacturer	Model	ID Num	Cal Due
LISN	Fischer Custom Communications, Inc	FCC-LISN-50/250-25-2-01-480V	175765	01/26/2023
EMI TEST RECEIVER	Rohde & Schwarz	ESR	93091	02/21/2023
Transient Limiter	TE	TBFL1	207996	06/01/2022
UL AUTOMATION SOFTWARE				
Radiated Software	UL	UL EMC	Rev 9.5, 03 Sept, 2020	
AC Line Conducted Software	UL	UL EMC	Rev 9.5, 07 Jul 2020	

7. RADIATED EMISSIONS

LIMIT

§18.301 Operating frequencies

The EUT operates at 917.5 MHz, within the tolerance of the ISM Frequency of 915 +/- 13MHz.

§18.305 Field Strength Limits

(b) The field strength levels of emissions which lie outside the bands specified in §18.301, unless otherwise indicated, shall not exceed the following:

Equipment	Operating frequency	RF Power generated by equipment (watts)	Field strength limit (µV/m)	Distance (meters)
Any type unless otherwise specified (miscellaneous)	Any ISM frequency	Below 500 500 or more	25 25 × SQRT(power/500)	300 ¹ 300

¹Field strength may not exceed 10µV/m at 1600 meters. Consumer equipment operating below 1000 MHz is not permitted the increase in field strength otherwise permitted here for power over 500 watts.

The RF Power generated by the equipment is below 500 W therefore the field strength limit is 25uV/m at 300 m, equivalent to 28 dBuV/m at 300 m.

This device also includes an ultrasonic sensor. The Part 18 limits for this sensor (ultrasonic operating below 500W at 175 kHz) are 2,400/F(kHz) at 300m, and so the limit is 13.7 uV/m (22.7 dBuV/m) at 300m for the frequency range 9kHz – 30 MHz (18.309). Emissions are evaluated in section 8.1

FCC §15.209 Limit

Frequency Range (MHz)	Field Strength Limit (uV/m) at 3 m	Field Strength Limit (dBuV/m) at 3 m
0.009-0.490	2400/F(kHz) @ 300 m	-
0.490-1.705	24000/F(kHz) @ 30 m	-
1.705 - 30	30 @ 30m	-
30 - 88	100	40
88 - 216	150	43.5
216 - 960	200	46
Above 960	500	54

TEST PROCEDURE

Tested in accordance with FCC / OST MP-5

The frequency range was investigated from 9 kHz to 10 GHz. An EUT which is normally operated on a table shall be placed on a non-conducting table having a height of 1 meter above test site ground level for all frequency ranges.

For pre-scans above 1 GHz the resolution bandwidth is set to 1 MHz; the video bandwidth is set to 30 KHz for peak measurements.

For final measurements above 1 GHz the resolution bandwidth is set to 1 MHz; the video bandwidth is set to 3 MHz for peak measurements and as applicable for average measurements. The detector function selector shall be set to average, unless otherwise specified for a given device.

For below 30MHz testing, investigation was done on three antenna orientations (parallel, perpendicular, and ground-parallel), parallel and perpendicular are the worst orientations, therefore testing was performed on these two orientations only. Blue color trace on plots: Parallel orientation. Green color trace on plots: Perpendicular orientation. For a loop antenna, the antenna height shall be set at around 2 meters.

KDB 414788 Open Field Site(OFS) and Chamber Correlation Justification

For below 30MHz testing, based on KDB 414788, Clause 2, for Part 18 equipment, Section 2.1 of FCC Measurement Procedure MP-5 also permits the use of test sites other than an open-field test site only if it can be shown that the results obtained at such a location are correlated with those made at an open-field test site.

OFS and chamber correlation testing had been performed and chamber measured test result is the worst case test result.

Distance Correction Factor

Based on FCC 18.305, note 2. Testing for compliance with these limits may be made at closer distances, provided a sufficient number of measurements are taken to plot the radiation pattern, to determine the major lobes of radiation, and to determine the expected field strength level at 30, 300, or 1600 meters. Alternatively, if measurements are made at only one closer fixed distance, then the permissible field strength limits shall be adjusted using $1/d$ as an attenuation factor.

- Distance factor from 3m to 300m = $20\log(3/300) = -40\text{dB}$

RESULTS

7.1. SPURIOUS EMISSIONS 9 kHz TO 30 MHz

7.1.1. CONFIGURATION 1

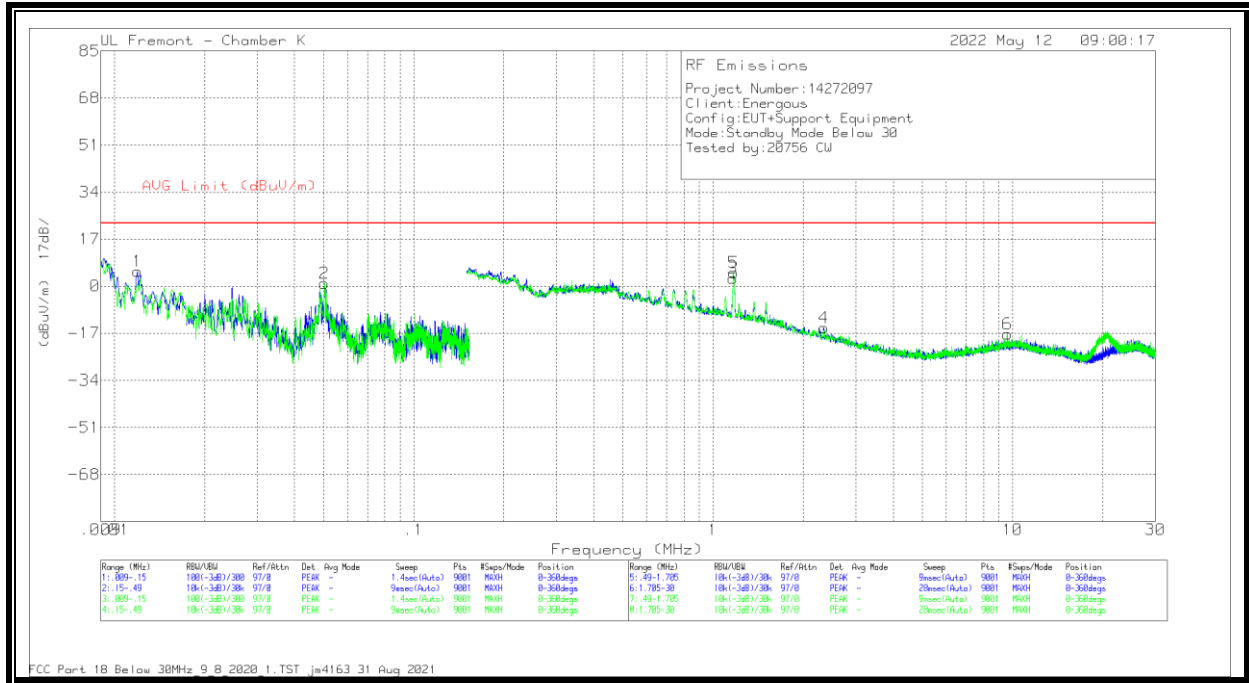

DATA

Marker	Frequency (MHz)	Meter Reading (dBuV)	Det	Loop Antenna (E ACF)	Amp/Cbl (dB)	Dist Corr 300m	Corrected Reading (dBuV/m)	AVG Limit (dBuV/m)	Margin (dB)	Azimuth (Degs)
1	.012	16.24	Pk	60.1	-31	-40	5.34	22.7	-17.36	0-360
2	.0504	16.26	Pk	57.1	-32.2	-40	1.16	22.7	-21.54	0-360
3	1.1658	29.15	Pk	45.8	-32.1	-40	2.85	22.7	-19.85	0-360
4	2.3401	16.6	Pk	40.5	-32.1	-40	-15	22.7	-37.7	0-360
5	1.1702	31.29	Pk	45.8	-32.1	-40	4.99	22.7	-17.71	0-360
6	9.5964	20.44	Pk	34.2	-31.8	-40	-17.16	22.7	-39.86	0-360

Pk - Peak detector

Note:

- Test was performed @ 3 meter distance.
- Distance factor from 3m to 300m = $20\log(3/300) = -40\text{dB}$
- The limit line is shown at 22.7 dBuV/m in the plot to reflect the lower limits for the ultrasonic sensor. The ultrasonic sensor's signal is too weak to notice.

7.1.2. CONFIGURATION 2 Part 18 Limit

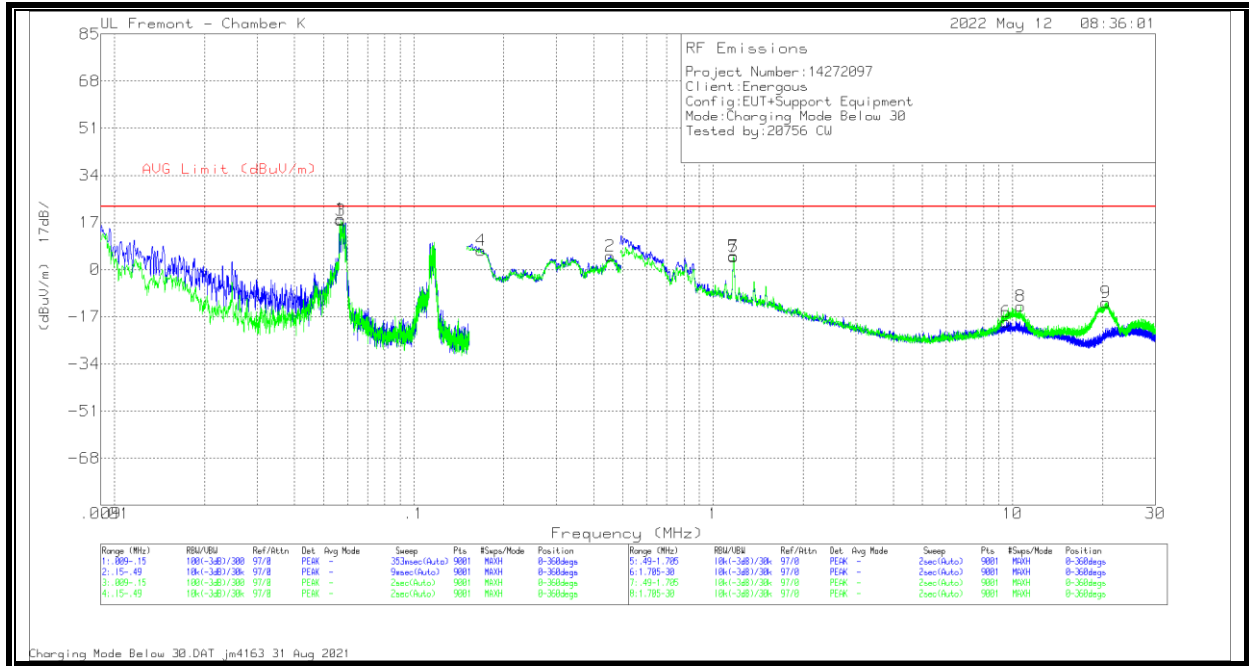

DATA

Marker	Frequency (MHz)	Meter Reading (dBuV)	Det	Loop Antenna (E ACF)	Amp/Cbl (dB)	Dist Corr 300m	Corrected Reading (dBuV/m)	AVG Limit (dBuV/m)	Margin (dB)	Azimuth (Degs)
1	.057	34.06	PK	56.5	-32.2	-40	18.36	28	-9.64	0-360
2	.4532	20.88	PK	56.2	-32.2	-40	4.88	28	-23.12	0-360
3	.057	33.58	PK	56.5	-32.2	-40	17.88	28	-10.12	0-360
4	.1677	23.17	PK	56	-32.2	-40	6.97	28	-21.03	0-360
5	1.1691	31.02	PK	45.8	-32.1	-40	4.72	28	-23.28	0-360
6	9.5178	18.96	PK	34.2	-31.9	-40	-18.74	28	-46.74	0-360
7	1.1702	31.2	PK	45.8	-32.1	-40	4.9	28	-23.1	0-360
8	10.6528	24.3	PK	34.2	-31.8	-40	-13.3	28	-41.3	0-360
9	20.525	26.29	PK	33.4	-31.6	-40	-11.91	28	-39.91	0-360

Note:

- Test was performed @ 3 meter distance.
- Distance factor from 3m to 300m = $20\log(3/300) = -40\text{dB}$

7.1.3. CONFIGURATION 2 Part 15.209 Limit

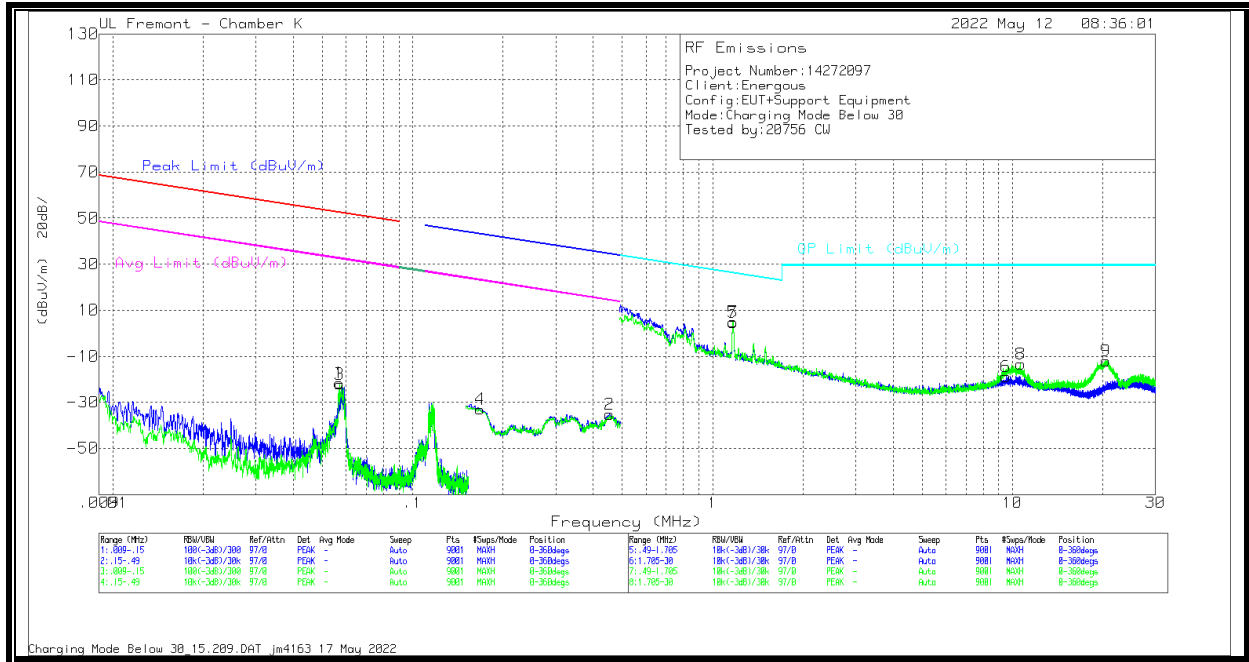

DATA

Marker	Frequency (MHz)	Meter Reading (dBuV)	Det	Loop Antenna (E ACF)	Amp/Cbl (dB)	Dist Corr 300m	Corrected Reading (dBuV/m)	Peak Limit (dBuV/m)	Margin (dB)	Avg Limit (dBuV/m)	Margin (dB)	Peak Limit (dBuV/m)	Margin (dB)	Avg Limit (dBuV/m)	Margin (dB)	Azimuth (Degs)	
1	.057	34.06	Pk	56.5	-32.2	-80	-21.64	52.47	-74.11	32.47	-54.11	-	-	-	-	-	0-360
2	.4532	20.88	Pk	56.2	-32.2	-80	-35.12	-	-	-	-	34.48	-69.6	14.48	-49.6	-	0-360
3	.057	33.58	Pk	56.5	-32.2	-80	-22.12	52.46	-74.58	32.46	-54.58	-	-	-	-	-	0-360
4	.1677	23.17	Pk	56	-32.2	-80	-33.03	-	-	-	-	43.13	-76.16	23.13	-56.16	-	0-360

Marker	Frequency (MHz)	Meter Reading (dBuV)	Det	Loop Antenna (E ACF)	Amp/Cbl (dB)	Dist Corr 30m (dB)	Corrected Reading (dBuV/m)	QP Limit (dBuV/m)	Margin (dB)	Azimuth (Degs)
5	1.1691	31.02	Pk	45.8	-	-40	4.72	26.27	-21.55	0-360
6	9.5178	19.96	Pk	34.2	-	-40	-18.74	29.5	-48.24	0-360
7	1.1702	31.2	Pk	45.8	-	-40	4.9	26.26	-21.36	0-360
8	10.6528	24.3	Pk	34.2	-	-40	-13.3	29.5	-42.8	0-360
9	20.525	26.29	Pk	33.4	-	-40	-11.91	29.5	-41.41	0-360

Pk - Peak detector
 Av - Average detection

Note:

- Test was performed @ 3 meter distance.
- Results are reported for 15.209 for the purposes of assessment against draft KDB 680106 for charging at distances greater than 1m

7.2. SPURIOUS EMISSIONS 30 MHz TO 1000 MHz

7.2.1. CONFIGURATION 1

Spurious Emissions 30 – 1000 MHz

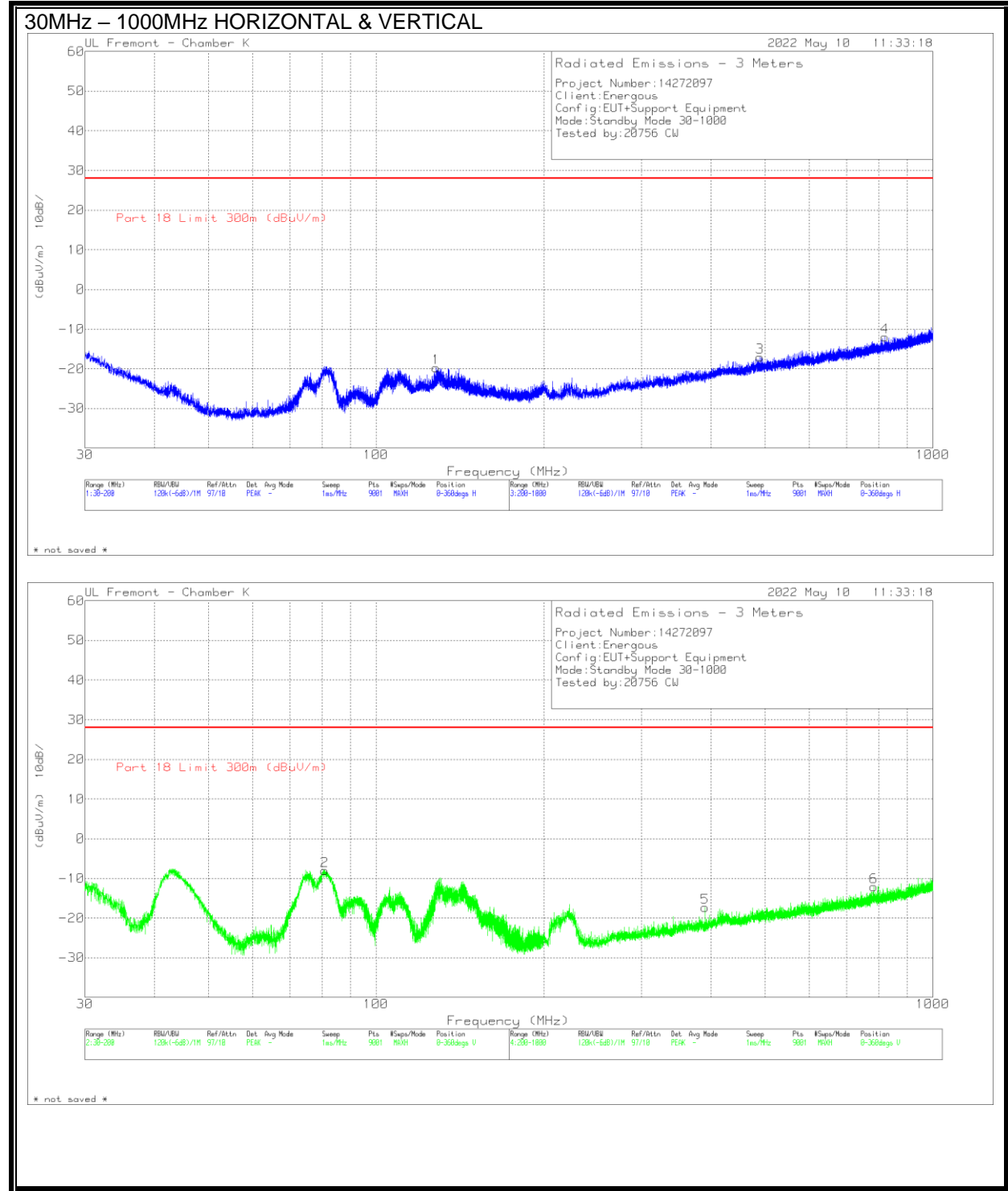

DATA

Marker	Frequency (MHz)	Meter Reading (dBuV)	Det	82258 ACF (dB)	Amp/Cbl (dB)	Dist Corr (dB)	Corrected Reading (dBuV/m)	Part 18 Limit 300m (dBuV/m)	Margin (dB)	Azimuth (Degs)	Height (cm)	Polarity
1	128.192	32.65	Pk	20.3	-30.7	-40	-17.75	28	-45.75	190	193	H
	128.192	15.29	Av	20.3	-30.7	-40	-35.11	28	-63.11	190	193	H
2	81.6432	50.12	Pk	13.5	-31	-40	-7.38	28	-35.38	184	104	V
	81.6432	25.18	Av	13.5	-31	-40	-32.32	28	-60.32	184	104	V
3	489.34	27.92	Pk	24	-29.1	-40	-17.18	28	-45.18	248	347	H
	489.34	13.81	Av	24	-29.1	-40	-31.29	28	-59.29	248	347	H
4	819.716	26.86	Pk	28	-27.8	-40	-12.94	28	-40.94	41	216	H
	819.716	13.33	Av	28	-27.8	-40	-26.47	28	-54.47	41	216	H
5	389.924	28.79	Pk	21.7	-29.3	-40	-18.81	28	-46.81	241	116	V
	389.924	13.8	Av	21.7	-29.3	-40	-33.8	28	-61.8	241	116	V
6	784.153	27.4	Pk	27.8	-27.8	-40	-12.6	28	-40.6	297	325	V
	784.154	13.31	Av	27.8	-27.8	-40	-26.69	28	-54.69	297	325	V

Pk - Peak detector
 Av - Average detection

Note:

- Test was performed @ 3 meter distance.
- Distance factor from 3m to 300m = $20\log(3/300) = -40\text{dB}$

7.2.2. CONFIGURATION 2 FCC Part 18 Limit

Spurious Emissions 30 – 1000 MHz with a Band Reject Filter

30MHz – 902MHz HORIZONTAL & VERTICAL

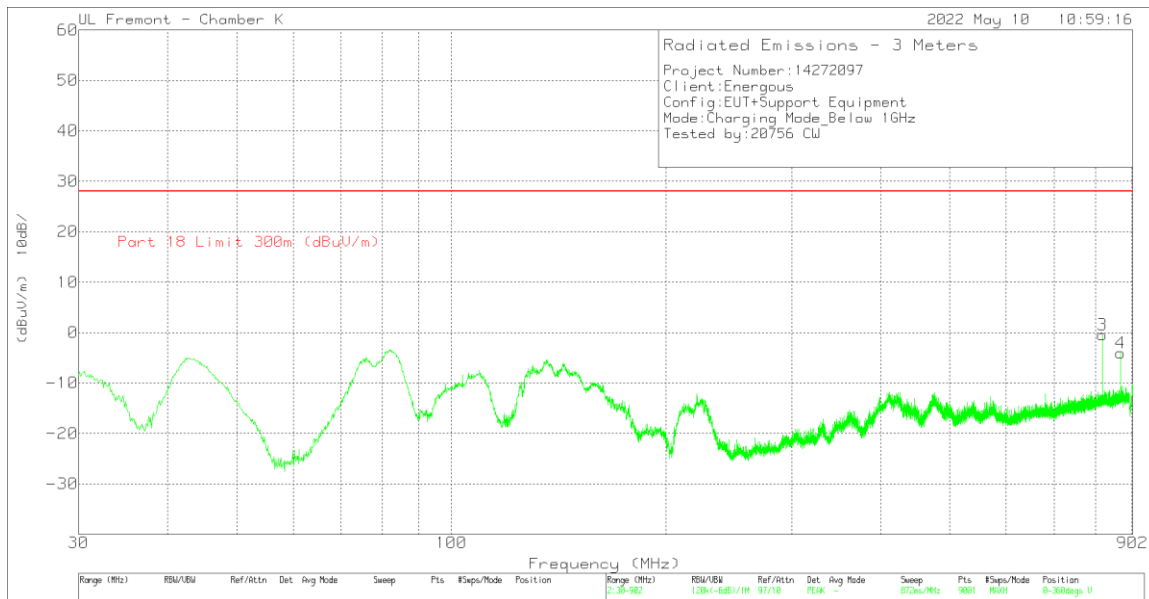
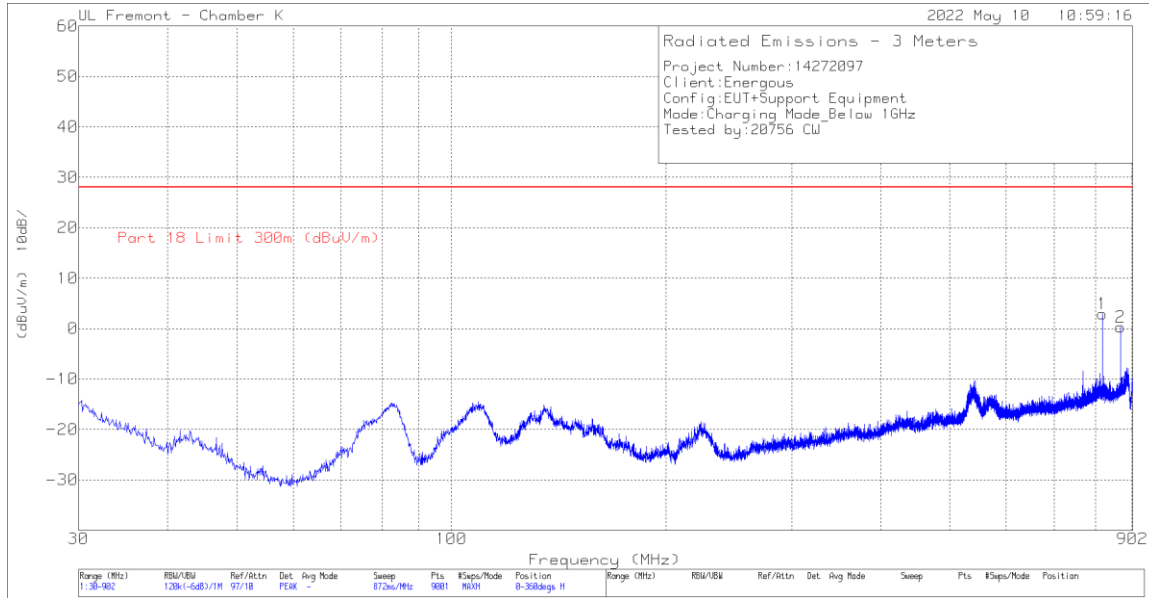

928MHz – 1000MHz HORIZONTAL & VERTICAL

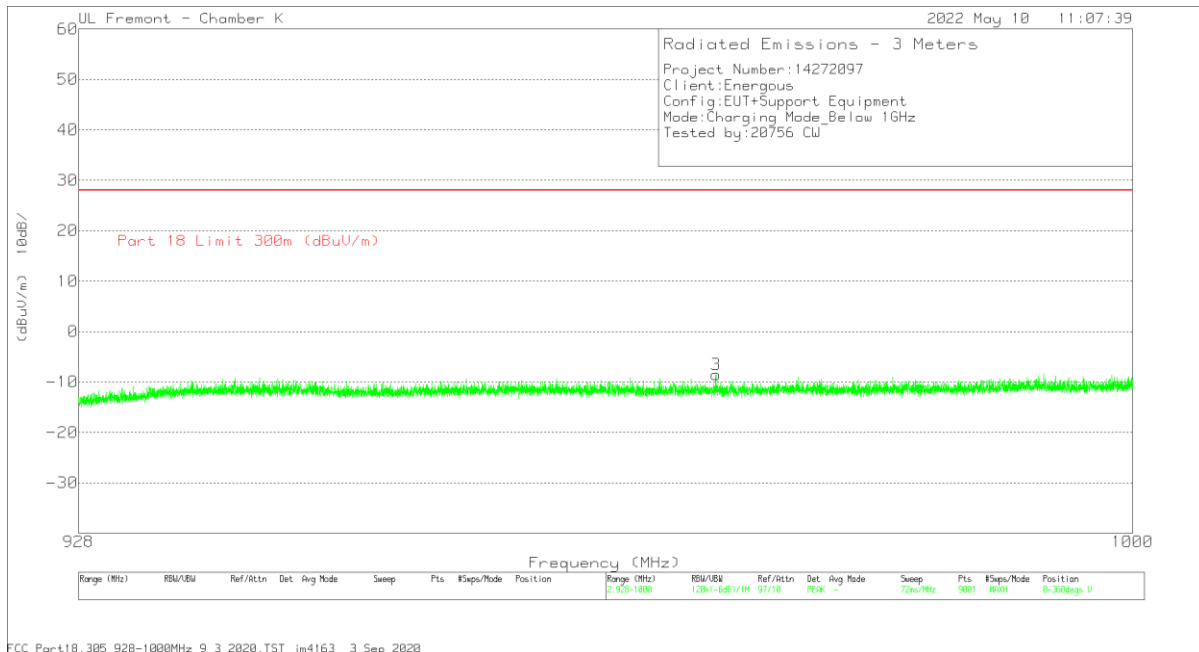
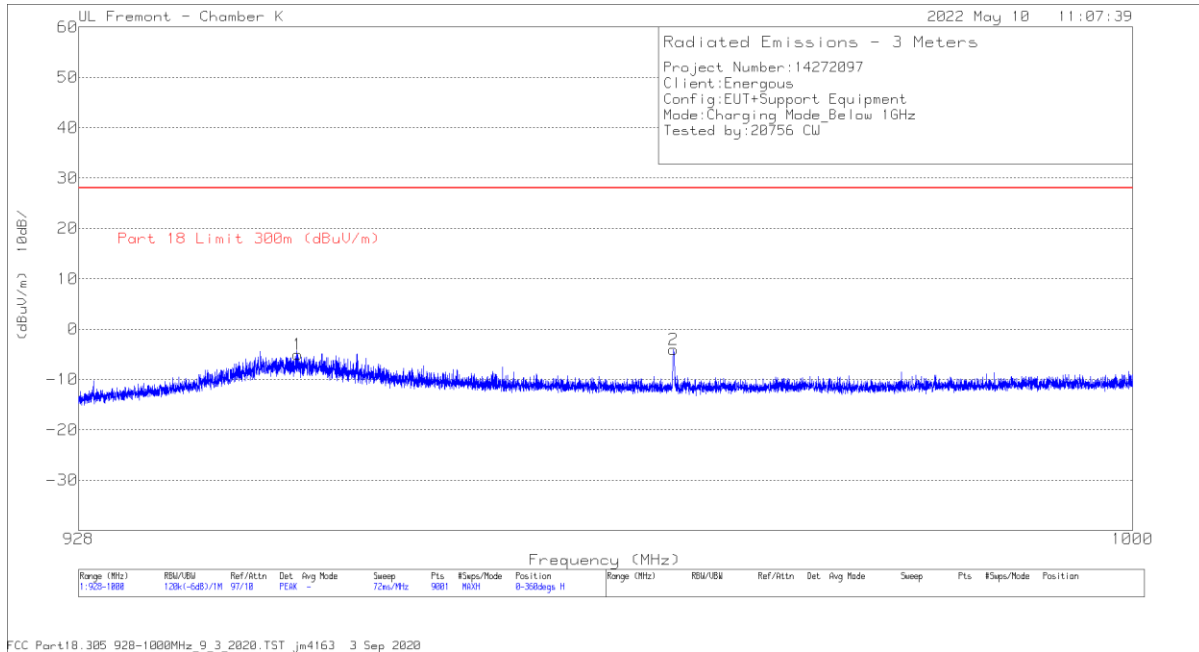

DATA

30MHz – 902MHz range

Marker	Frequency (MHz)	Meter Reading (dBuV)	Det	82258 ACF (dB)	Amp/Cbl (dB)	Dist Corr (dB)	156484 BRF (dB)	Corrected Reading (dBuV/m)	Part 18 Limit 300m (dBuV/m)	Margin (dB)	Azimuth (Degs)	Height (cm)	Polarity
1	817.995	43.29	Av	28	-27.8	-40	.8	4.29	28	-23.71	35	127	H
2	867.993	38.4	Pk	28.3	-27.2	-40	.8	.3	28	-27.7	0-360	99	H
3	818.095	38.58	Pk	28	-27.8	-40	.8	-42	28	-28.42	0-360	101	V
4	868.09	34.03	Pk	28.3	-27.2	-40	.8	-4.07	28	-32.07	0-360	101	V

Pk - Peak detector

Av - Average detection

928MHz – 1000MHz range

Marker	Frequency (MHz)	Meter Reading (dBuV)	Det	82258 ACF (dB)	Amp/Cbl (dB)	Dist Corr (dB)	156484 BRF (dB)	Corrected Reading (dBuV/m)	Part 18 Limit 300m (dBuV/m)	Margin (dB)	Azimuth (Degs)	Height (cm)	Polarity
1	942.552	31.41	Pk	29.4	-26.6	-40	.8	-4.99	28	-32.99	0-360	101	H
2	968.003	28.78	Av	29.4	-26.2	-40	.8	-7.22	28	-35.22	52	105	H
3	970.888	27.34	Pk	29.4	-26.1	-40	.8	-8.56	28	-36.56	0-360	197	V

Pk - Peak detector

Av - Average detection

Note:

- Test was performed @ 3 meter distance.
- Distance factor from 3m to 300m = $20\log(3/300) = -40\text{dB}$
- Band Reject Filter was used to prevent system overloading

Spurious Emissions 800 – 1000 MHz without a Band Reject Filter and without amplifier

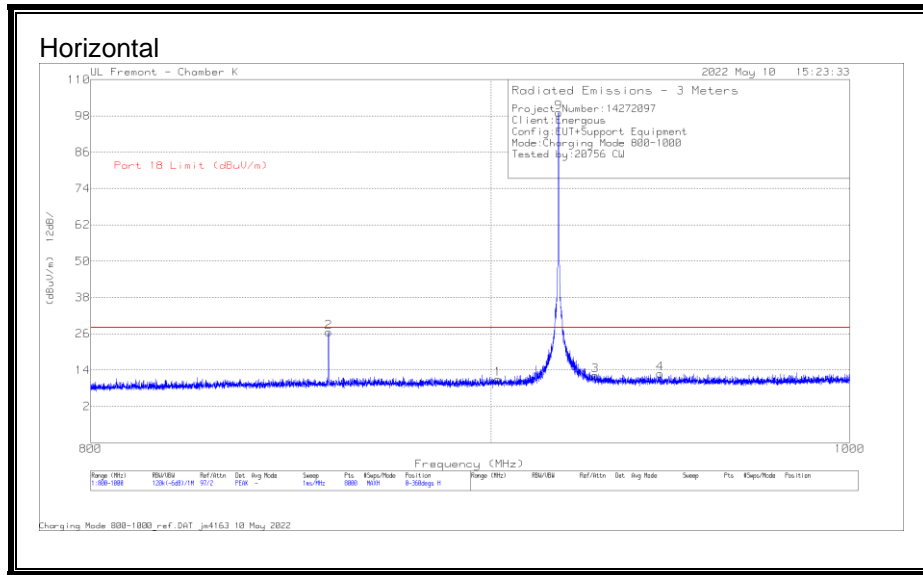

DATA

Marker	Frequency (MHz)	Meter Reading (dBUV)	Det	82258 ACF (dB)	Bypass Cable (dB)	Dist Corr (dB)	Corrected Reading (dBUV/m)	Part 18 Limit 300m (dBUV/m)	Margin (dB)	Azimuth (Degs)	Height (cm)	Polarity
2	857.982	34.02	Pk	28.2	4.3	-40	26.52	28	-1.48	0-360	99	H
	858.118	-3.7	Av	28.2	4.3	-40	-11.2	28	-39.2	326	287	H
4	945.792	18.96	Pk	29.4	4.5	-40	12.86	28	-15.14	0-360	299	H
	946.032	-3.92	Av	29.4	4.5	-40	-10.02	28	-38.02	310	169	H

Fundamental at 3 meter (Horizontal polarity is the worst case)

Marker	Frequency (MHz)	Meter Reading (dBUV)	Det	82258 ACF (dB)	Bypass (dB)	Corrected Reading (dBUV/m)	Azimuth (Degs)	Height (cm)	Polarity
9	917.989	105.89	Pk	28.8	4.5	139.19	0-360	99	H

Pk - Peak detector

Av - Average detection

Note:

- Test was performed @ 3 meter distance.
- Distance factor from 3m to 300m = $20\log(3/300) = -40\text{dB}$

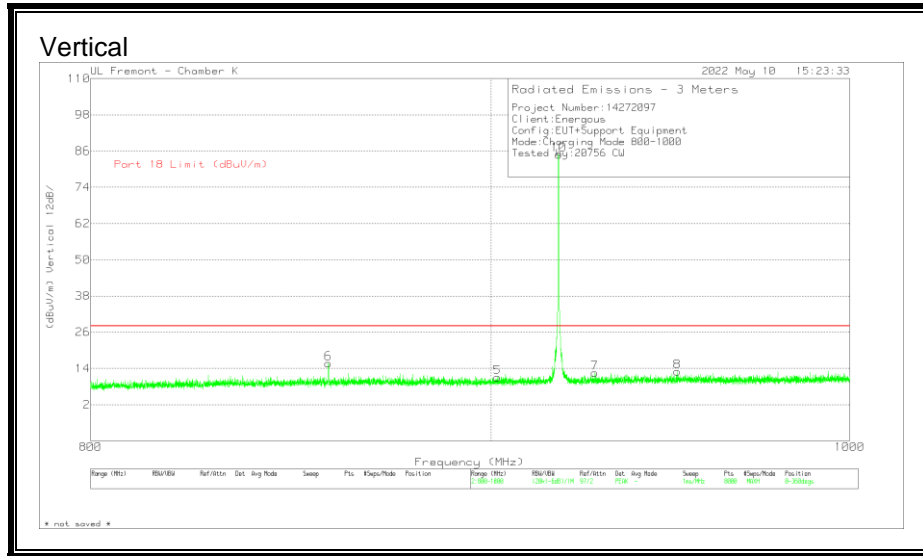

DATA

Marker	Frequency (MHz)	Meter Reading (dBuV)	Det	82258 ACF (dB)	Bypass Cable (dB)	Dist Corr (dB)	Corrected Reading (dBuV/m)	FCC PART18 300m LIMIT (dBuV/m)	Margin (dB)	Azimuth (Degs)	Height (cm)	Polarity
6	857.957	23.25	Pk	28.2	4.3	-40	15.75	28	-12.25	0-360	100	V
	858.007	-3.86	Av	28.2	4.3	-40	-11.36	28	-39.36	143	298	V
8	950.568	19.06	Pk	29.4	4.6	-40	13.06	28	-14.94	0-360	199	V
	950.79	-3.96	Av	29.4	4.6	-40	-9.96	28	-37.96	306	114	V

Pk - Peak detector
 Av - Average detection

Note:

- Test was performed @ 3 meter distance.
- Distance factor from 3m to 300m = $20\log(3/300) = -40\text{dB}$

7.2.3. CONFIGURATION 2 FCC Part 15.209 Limit

Spurious Emissions 30 – 1000 MHz with a Band Reject Filter

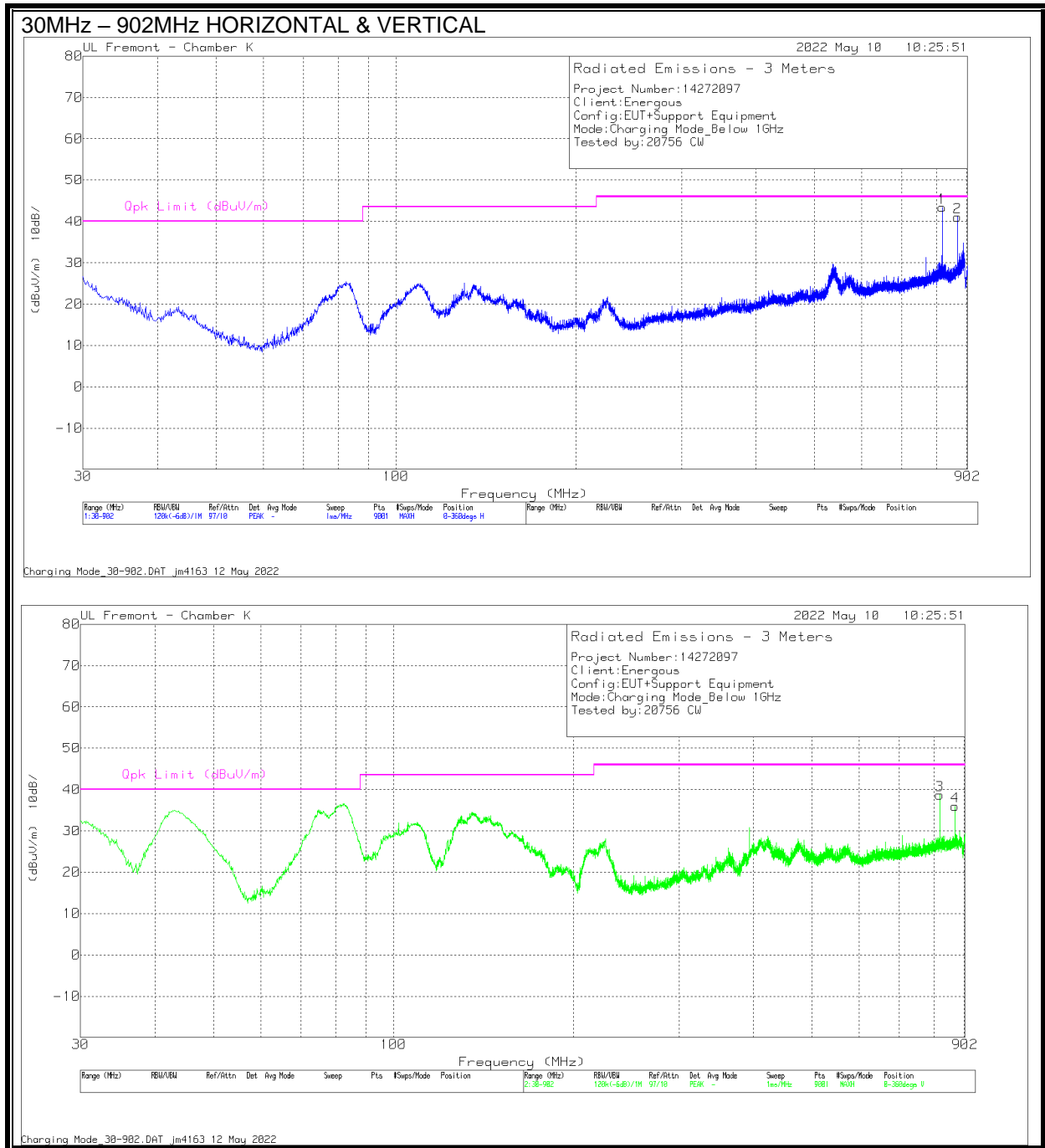

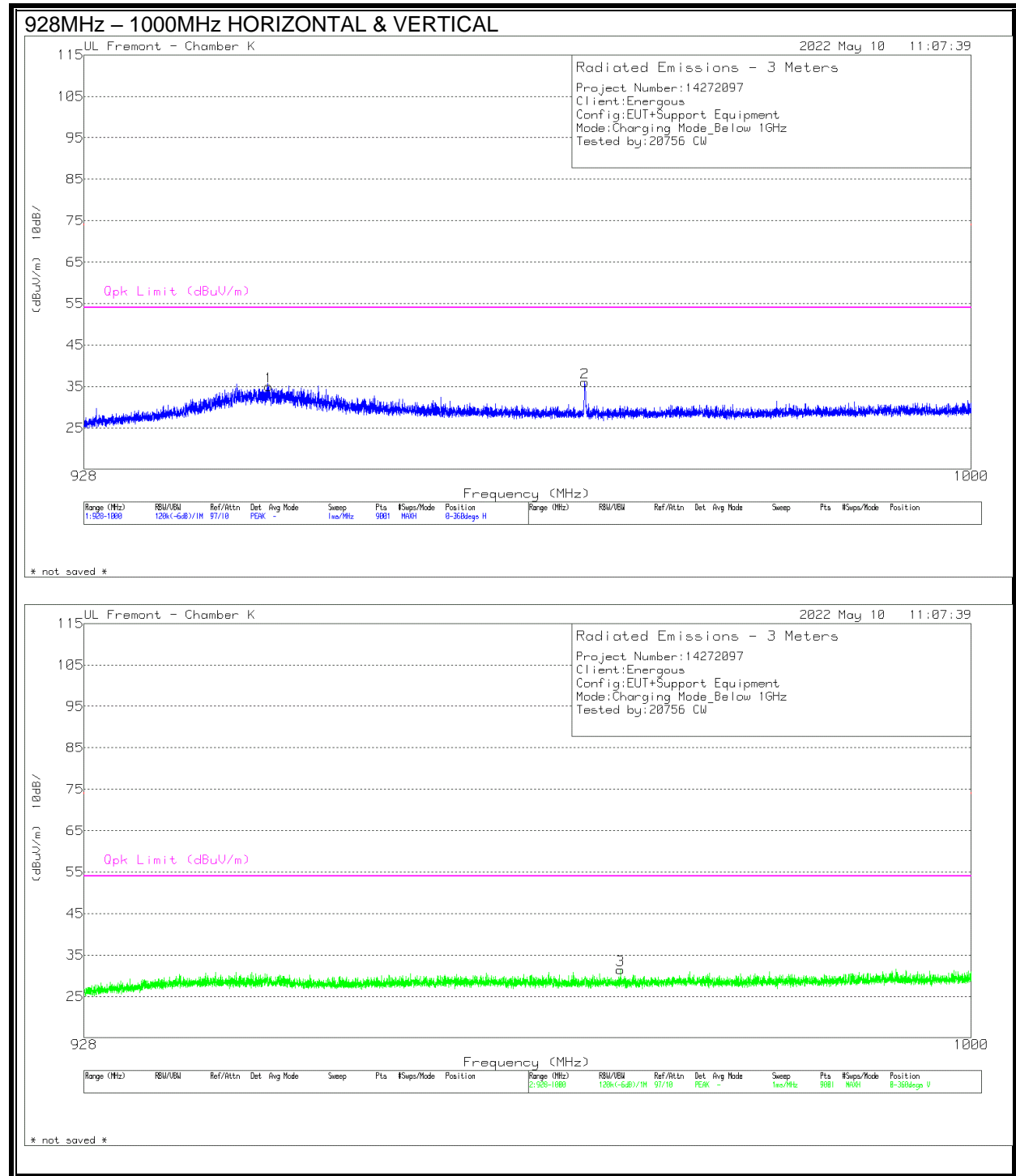

DATA

30MHz – 902MHz range

Marker	Frequency (MHz)	Meter Reading (dBuV)	Det	82258 ACF (dB)	Amp/Cbl (dB)	156484 BRF (dB)	Corrected Reading (dBuV/m)	Part15.209 Qpk Limit (dBuV/m)	Margin (dB)	Azimuth (Degs)	Height (cm)	Polarity
1	817.995	44.9	Pk	28	-27.8	.8	45.9	46	-.1	35	127	H
2	867.989	43.84	Pk	28.3	-27.2	.8	45.74	46	-.26	31	113	H
3	817.989	39.45	Pk	28	-27.8	.8	40.45	46	-5.55	57	100	V
4	867.985	34.72	Pk	28.3	-27.2	.8	36.62	46	-9.38	44	102	V

Pk - Peak detector

928MHz – 1000MHz range

Marker	Frequency (MHz)	Meter Reading (dBuV)	Det	82258 ACF (dB)	Amp/Cbl (dB)	156484 BRF (dB)	Corrected Reading (dBuV/m)	Part15.209 Qpk Limit (dBuV/m)	Margin (dB)	Azimuth (Degs)	Height (cm)	Polarity
1	942.421	33.31	Pk	29.3	-26.6	.8	36.81	54	-17.19	40	113	H
2	* 968.003	33.12	Pk	29.4	-26.2	.8	37.12	54	-16.88	52	105	H
3	* 970.689	26.23	Pk	29.4	-26.2	.8	30.23	54	-23.77	227	262	V

Pk - Peak detector

* - indicates frequency in CFR47 Pt 15 / IC RSS-Restricted Band

Note:

- Test was performed @ 3 meter distance.
- Band Reject Filter was used to prevent system overloading
- Results are reported for 15.209 for the purposes of assessment against draft KDB 680106 for charging at distances greater than 1m

Spurious Emissions 800 – 1000 MHz without a Band Reject Filter and without amplifier

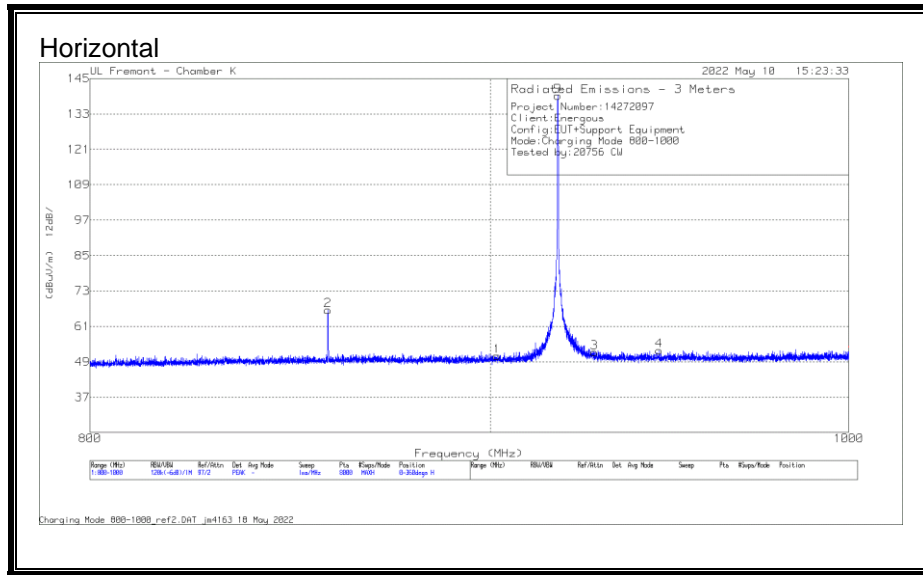

DATA

Marker	Frequency (MHz)	Meter Reading (dBuV)	Det	82258 ACF (dB)	Bypass (dB)	Corrected Reading (dBuV/m)	Part15.209 Qpk Limit (dBuV/m)	Margin (dB)	Azimuth (Degs)	Height (cm)	Polarity
2	858.118	16.45	Pk	28.2	4.3	48.95	46	2.95	326	287	H
4	946.032	15.46	PK	29.4	4.5	49.36	46	3.36	310	169	H

Pk - Peak detector

Note:

- Test was performed @ 3 meter distance.
- Results are reported for 15.209 for the purposes of assessment against draft KDB 680106 for charging at distances greater than 1m

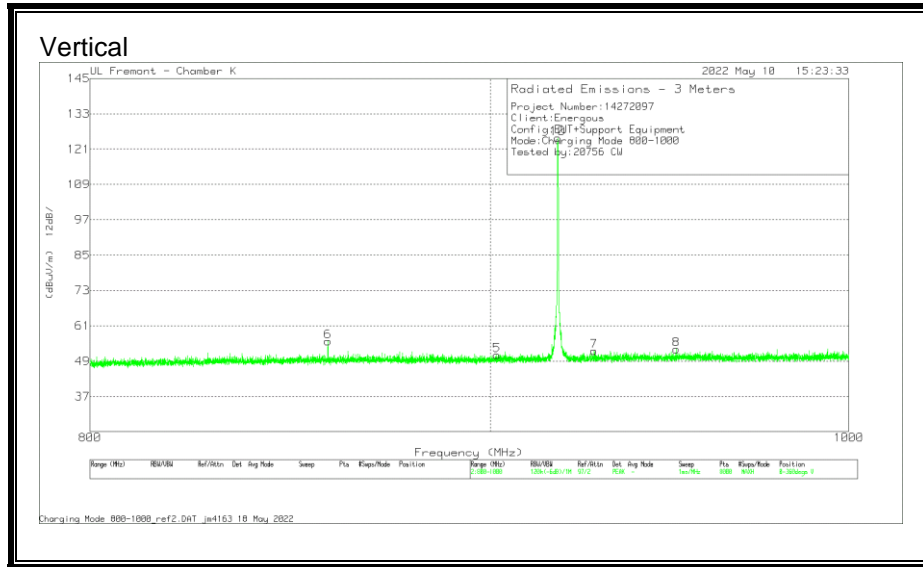

DATA

Marker	Frequency (MHz)	Meter Reading (dBuV)	Det	82258 ACF (dB)	Bypass (dB)	Corrected Reading (dBuV/m)	Part15.209 Qpk Limit (dBuV/m)	Margin (dB)	Azimuth (Degs)	Height (cm)	Polarity
6	857.957	23.25	Pk	28.2	4.3	55.75	46	9.75	0-360	100	V
8	950.568	19.06	Pk	29.4	4.6	53.06	46	7.06	0-360	199	V

Pk - Peak detector

Note:

- Test was performed @ 3 meter distance.
- Results are reported for 15.209 for the purposes of assessment against draft KDB 680106 for charging at distances greater than 1m

7.3. SPURIOUS EMISSIONS 1 GHz TO 10 GHz

7.3.1. CONFIGURATION 1

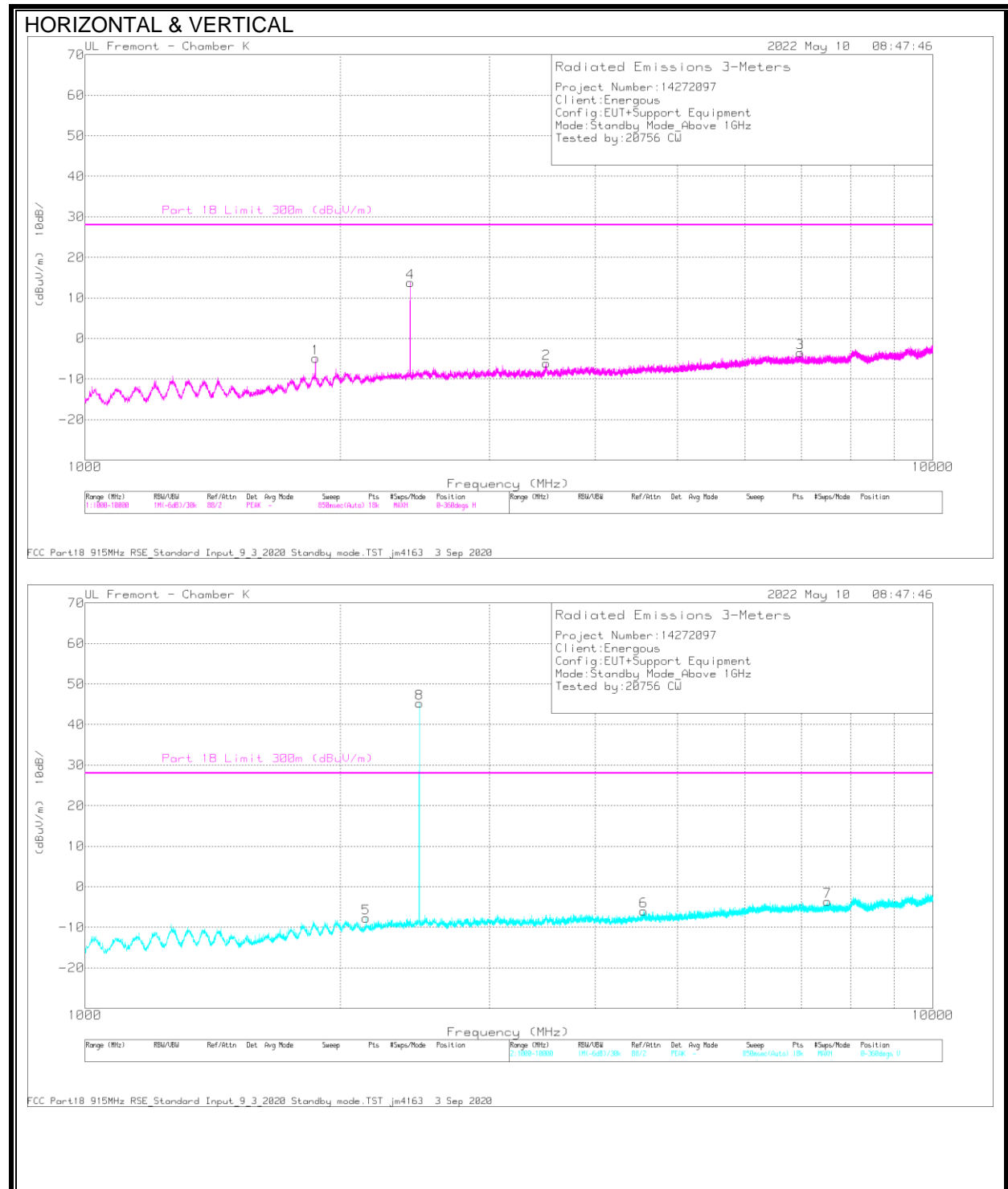

DATA

Marker	Frequency (MHz)	Meter Reading (dBuV)	Det	AF 80404 (dB/m)	Amp/Cbl/(dB)	Dist Corr (dB)	Corrected Reading (dBuV/m)	Part 18 Limit 300m (dBuV/m)	Margin (dB)	Azimuth (Degs)	Height (cm)	Polarity
1	1870.328	54.84	Pk	30.9	-45.6	-40	0.14	28	-27.86	65	117	H
	1870.328	41.64	Av	30.9	-45.6	-40	-13.06	28	-41.06	65	117	H
2	3501.605	50.26	Pk	34.2	-42	-40	2.46	28	-25.54	222	108	H
	3501.605	36.94	Av	34.2	-42	-40	-10.86	28	-38.86	222	108	H
3	6982.288	46.98	Pk	35.8	-37.8	-40	4.98	28	-23.02	32	304	H
	6982.288	33.38	Av	35.8	-37.8	-40	-8.62	28	-36.62	32	304	H
5	2146.648	54.35	Pk	31.5	-45	-40	0.85	28	-27.15	358	288	V
	2146.648	40.46	Av	31.5	-45	-40	-13.04	28	-41.04	358	288	V
6	4560.828	49.58	Pk	34.2	-41	-40	2.78	28	-25.22	21	339	V
	4560.828	36.32	Av	34.2	-41	-40	-10.48	28	-38.48	21	339	V
7	7511.637	45.83	Pk	35.9	-37.2	-40	4.53	28	-23.47	4	135	V
	7511.637	32.97	Av	35.9	-37.2	-40	-8.33	28	-36.33	4	135	V

Pk - Peak detector
 Av - Average detection

Note:

- Test was performed @ 3 meter distance.
- Distance factor from 3m to 300m = $20\log(3/300) = -40\text{dB}$
- Worst highest 6 markers frequencies are picked.
- Markers 4, 8 are BLE signals

7.3.2. CONFIGURATION 2 FCC Part 18 Limit

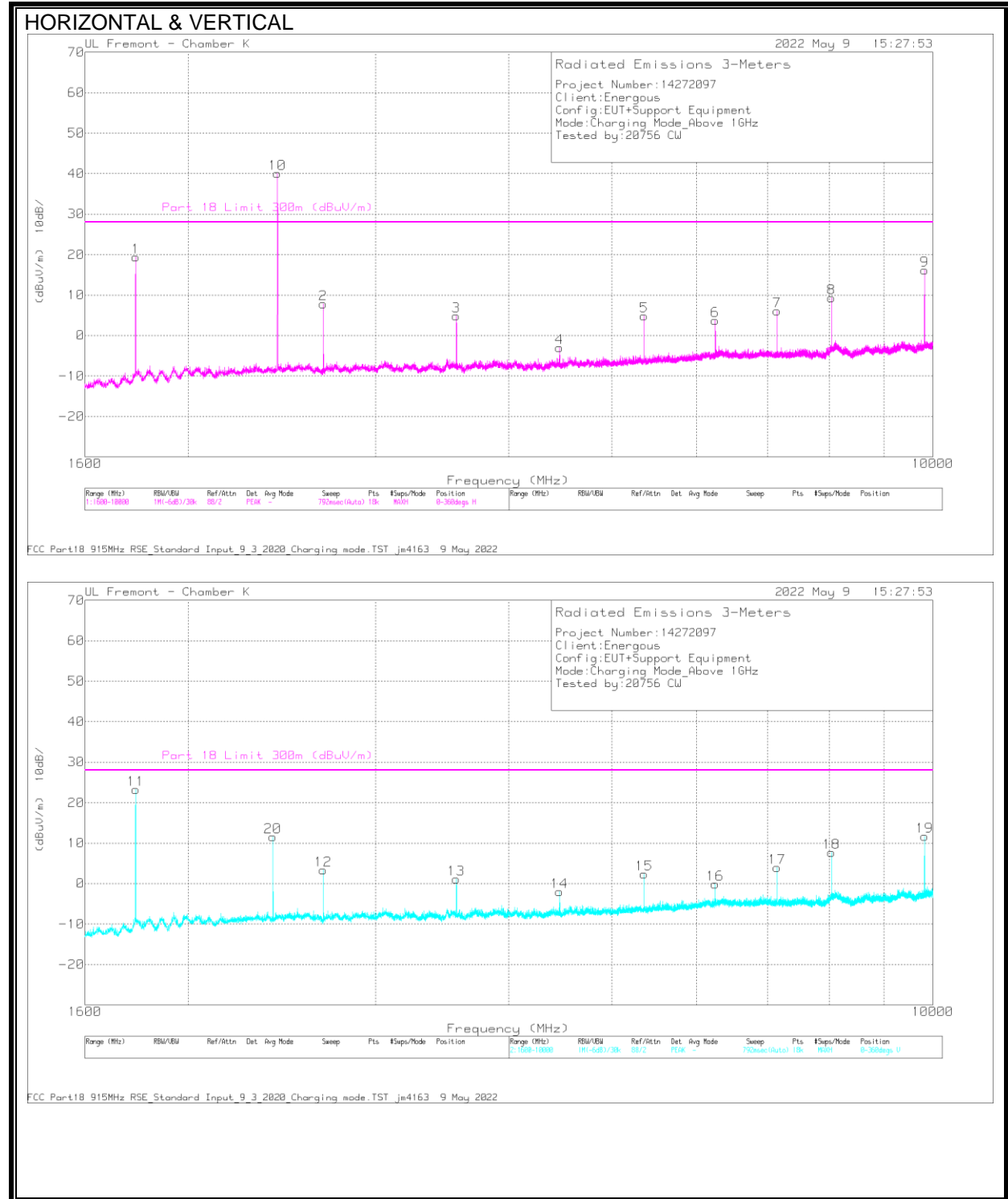

DATA

Marker	Frequency (MHz)	Meter Reading (dBuV)	Det	AF 80404 (dB/m)	Amp/Cbl/(dB)	204786 HPF (dB)	Dist Corr (dB)	Corrected Reading (dBuV/m)	Part 18 Limit 300m (dBuV/m)	Margin (dB)	Azimuth (Degs)	Height (cm)	Polarity
1	1785.808	78.28	Pk	30.1	-46	0.7	-40	23.08	28	-4.92	226	387	H
	1785.809	77.26	Av	30.1	-46	0.7	-40	22.06	28	-5.94	226	387	H
8	8036.056	52.94	Pk	35.9	-36.5	0.7	-40	13.04	28	-14.96	37	99	H
	8036.056	48.08	Av	35.9	-36.5	0.7	-40	8.18	28	-19.82	37	99	H
9	9821.819	58	Pk	37.1	-36.1	0.7	-40	19.7	28	-8.3	350	172	H
	9821.819	55.75	Av	37.1	-36.1	0.7	-40	17.45	28	-10.55	350	172	H
11	1785.8	82.28	Pk	30.1	-46	0.7	-40	27.08	28	-0.92	284	259	V
	1785.8	81.92	Av	30.1	-46	0.7	-40	26.72	28	-1.28	284	259	V
18	8036.152	52.34	Pk	35.9	-36.5	0.7	-40	12.44	28	-15.56	69	108	V
	8036.153	46.99	Av	35.9	-36.5	0.7	-40	7.09	28	-20.91	69	108	V
19	9821.919	54.11	Pk	37.1	-36.1	0.7	-40	15.81	28	-12.19	117	193	V
	9821.919	50.37	Av	37.1	-36.1	0.7	-40	12.07	28	-15.93	117	193	V

Pk - Peak detector
 Av - Average detection

Note:

- Test was performed @ 3 meter distance.
- Distance factor from 3m to 300m = $20\log(3/300) = -40\text{dB}$
- Frequency Range 1GHz – 1.6GHz was investigated due to using a 1.5GHz high pass filter. See the following test result of frequency range 1GHz-1.6GHz.
- Worst highest 6 markers frequencies are picked.
- Markers 10, 20 are BLE signals

Spurious Emissions 1GHz – 1.6GHz without a Band Reject Filter, without 1.5 GHz HPF, and without amplifier

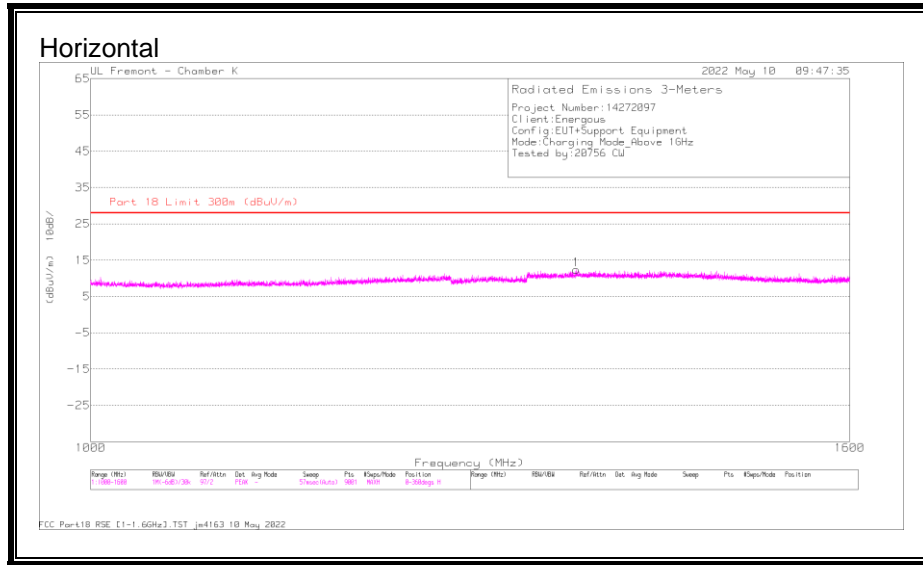

DATA

Marker	Frequency (GHz)	Meter Reading (dBuV)	Det	AF 80404 (dB/m)	Cable (dB)	Dist Corr (dB)	Corrected Reading (dBuV/m)	FCC PART18 300m LIMIT (dBuV/m)	Margin (dB)	Azimuth (Degs)	Height (cm)	Polarity
1	1350.735	17.47	Pk	29.2	5.7	-40	12.37	-	-	0-360	100	H
	1350.153	5.08	Av	29.2	5.7	-40	-0.02	28	-28.02	306	276	H

Pk - Peak detector
 Av - Average detection

Note:

- Test was performed @ 3 meter distance.
- Distance factor from 3m to 300m = $20\log(3/300) = -40\text{dB}$

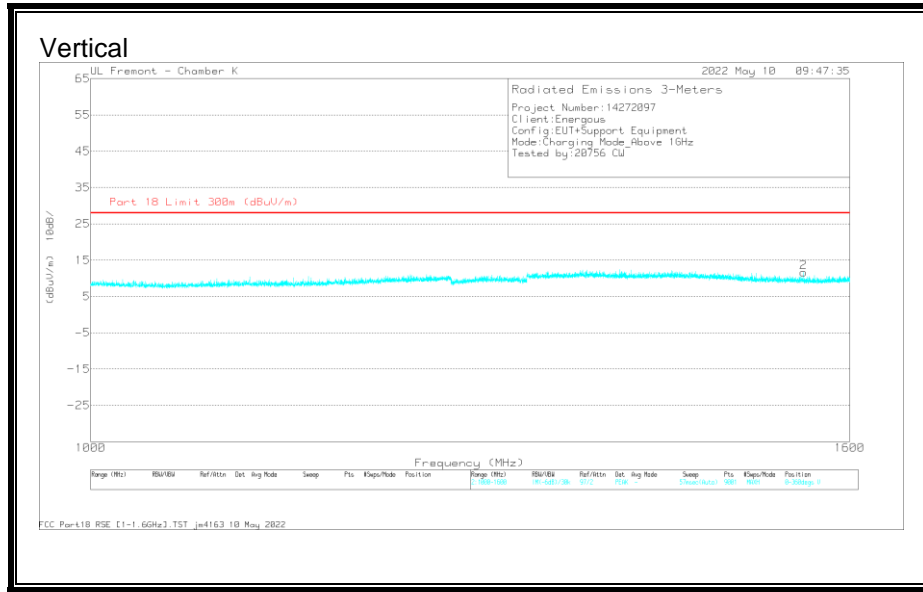

DATA

Marker	Frequency (GHz)	Meter Reading (dBuV)	Det	AF 80404 (dB/m)	Cable (dB)	Dist Corr (dB)	Corrected Reading (dBuV/m)	FCC PART18 300m LIMIT (dBuV/m)	Margin (dB)	Azimuth (Degs)	Height (cm)	Polarity
2	1555.069	17.55	Pk	28	6.1	-40	11.65	-	-	0-360	200	V
	1555.025	4.96	Av	28	6.1	-40	-94	28	-28.94	168	256	V

Pk - Peak detector
 Av - Average detection

Note:

- Test was performed @ 3 meter distance.
- Distance factor from 3m to 300m = $20\log(3/300) = -40\text{dB}$

7.3.3. CONFIGURATION 2 FCC Part 15.209 Limit

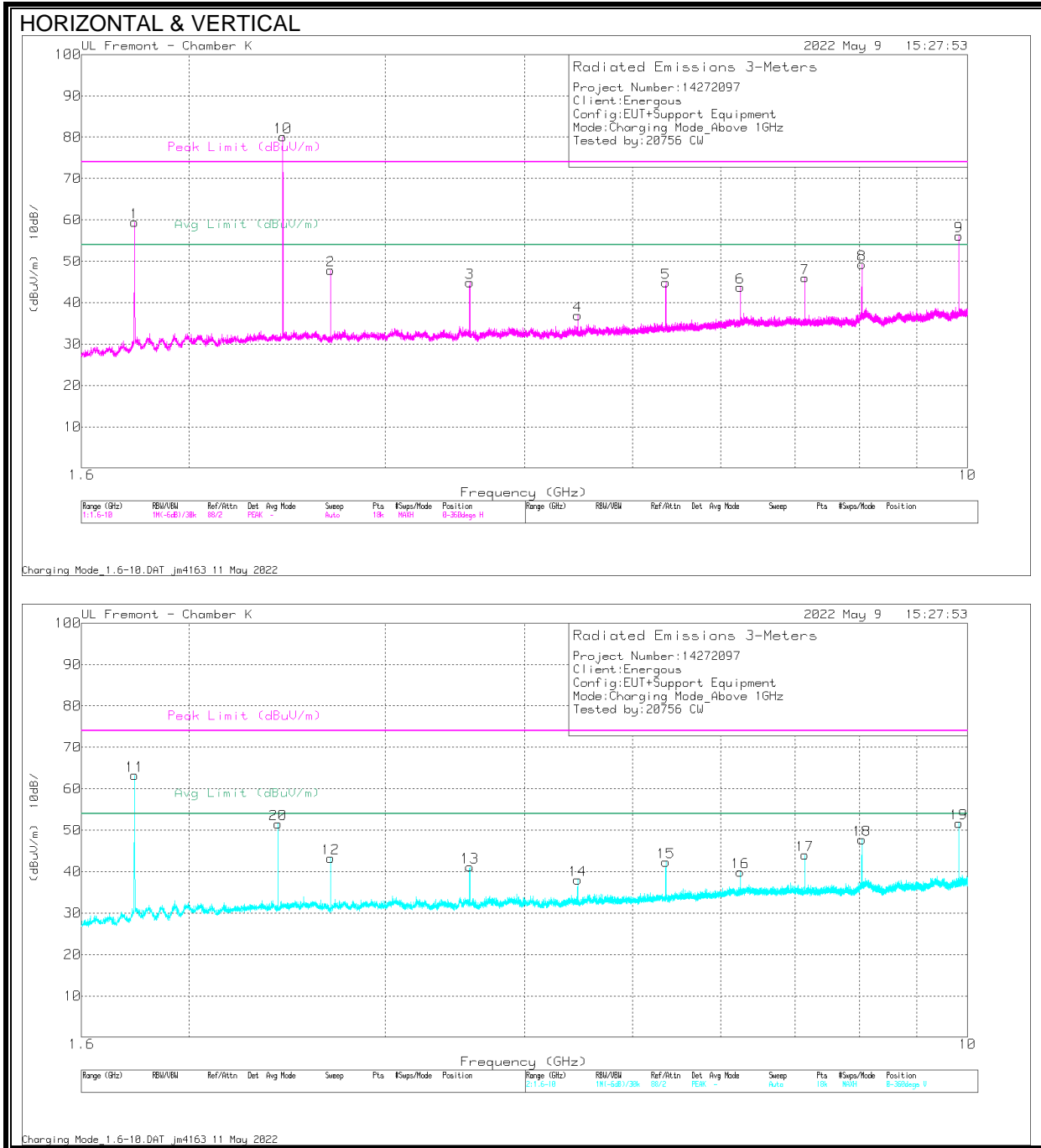

DATA

Marker	Frequency (GHz)	Meter Reading (dBuV)	Det	AF 80404 (dB/m)	Amp/Cbl(dB)	204786 HPF (dB)	Corrected Reading (dBuV/m)	Peak Limit (dBuV/m)	PK Margin (dB)	Avg Limit (dBuV/m)	Margin (dB)	Azimuth (Degs)	Height (cm)	Polarity
1	1.785808	78.28	Pk	30.1	-46	.7	63.08	74	-10.92	-	-	226	387	H
	1.785809	77.26	Av	30.1	-46	.7	62.06	-	-	54	8.06	226	387	H
8	* 8.036056	52.94	Pk	35.9	-36.5	.7	53.04	74	-20.96	-	-	37	99	H
	* 8.036056	48.08	Av	35.9	-36.5	.7	48.18	-	-	54	-5.82	37	99	H
9	9.821819	58	Pk	37.1	-36.1	.7	59.7	74	-14.3	-	-	350	172	H
	9.821819	55.75	Av	37.1	-36.1	.7	57.45	-	-	54	3.45	350	172	H
11	1.7858	82.28	Pk	30.1	-46	.7	67.08	74	-6.92	-	-	284	259	V
	1.7858	81.92	Av	30.1	-46	.7	66.72	-	-	54	12.72	284	259	V
18	* 8.036152	52.34	Pk	35.9	-36.5	.7	52.44	74	-21.56	-	-	69	108	V
	* 8.036153	46.99	Av	35.9	-36.5	.7	47.09	-	-	54	-6.91	69	108	V
19	9.821919	54.11	Pk	37.1	-36.1	.7	55.81	74	-18.19	-	-	117	193	V
	9.821919	50.37	Av	37.1	-36.1	.7	52.07	-	-	54	-1.93	117	193	V

* - indicates frequency in CFR47 Pt 15 / IC RSS-Restricted Band
 Pk - Peak detector
 Av - Average detection

Note:

- Test was performed @ 3 meter distance.
- Distance factor from 3m to 300m = $20\log(3/300) = -40\text{dB}$
- Frequency Range 1GHz – 1.6GHz was investigated due to using a 1.5GHz high pass filter. See the following test result of frequency range 1GHz-1.6GHz.
- Worst highest 6 markers frequencies are picked.
- Markers 10, 20 are BLE signals
- Results are reported for 15.209 for the purposes of assessment against draft KDB 680106 for charging at distances greater than 1m.

Spurious Emissions 1GHz – 1.6GHz without a Band Reject Filter, without 1.5 GHz HPF, and without amplifier

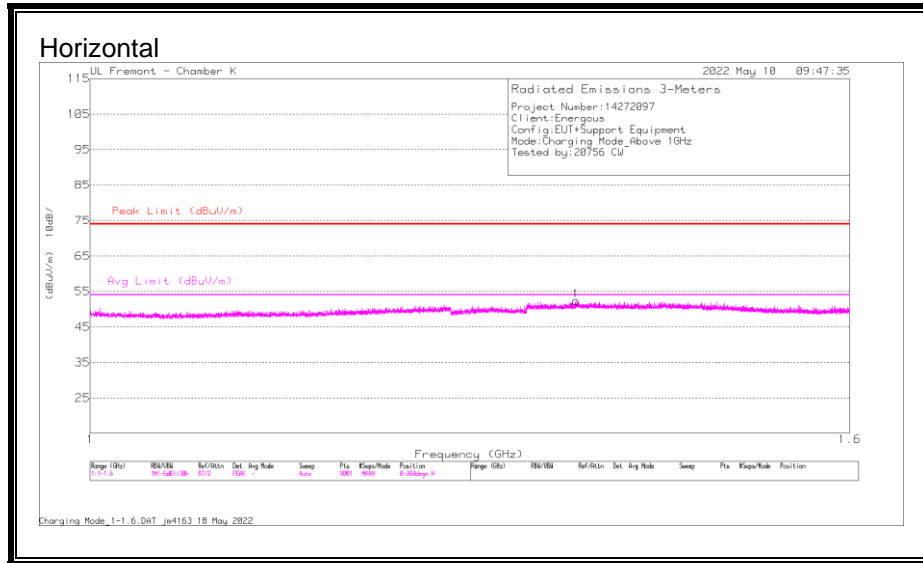

DATA

Marker	Frequency (GHz)	Meter Reading (dBuV)	Det	AF 80404 (dB/m)	Bypass (dB)	Corrected Reading (dBuV/m)	Peak Limit (dBuV/m)	PK Margin (dB)	Avg Limit (dBuV/m)	Margin (dB)	Azimuth (Degs)	Height (cm)	Polarity
1	* 1.350152	28.21	Pk	29.2	5.7	63.11	74	-10.89	-	-	306	276	H
	* 1.350153	5.08	Av	29.2	5.7	39.98	-	-	54	-14.02	306	276	H

Pk - Peak detector
 Av - Average detection

Note:

- Test was performed @ 3 meter distance.
- Results are reported for 15.209 for the purposes of assessment against draft KDB 680106 for charging at distances greater than 1m

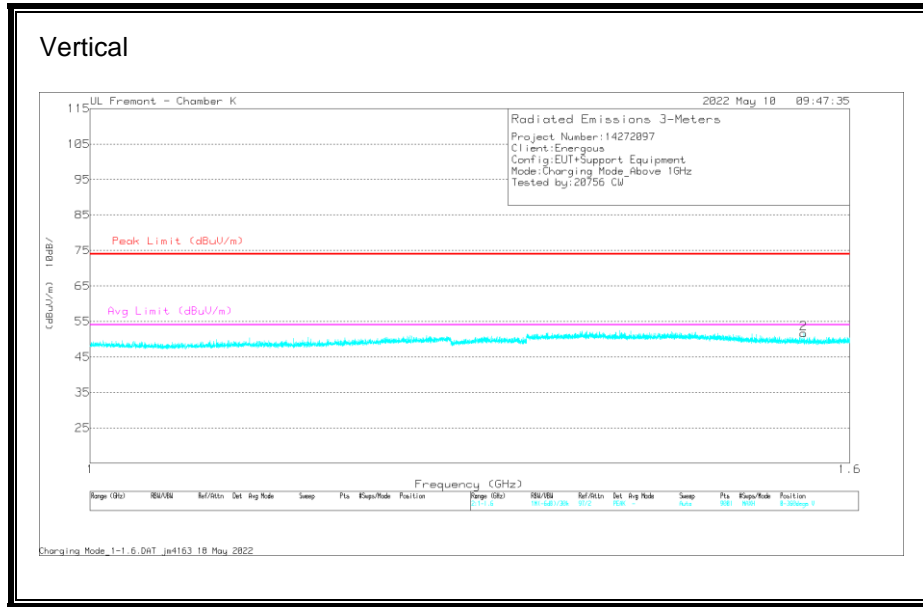

DATA

Marker	Frequency (GHz)	Meter Reading (dBuV)	Det	AF 80404 (dB/m)	Bypass (dB)	Corrected Reading (dBuV/m)	Peak Limit (dBuV/m)	PK Margin (dB)	Avg Limit (dBuV/m)	Margin (dB)	Azimuth (Degs)	Height (cm)	Polarity
2	* 1.555025	26.91	Pk	28	6.1	61.01	74	-12.99	-	-	168	256	V
	* 1.555025	4.96	Av	28	6.1	39.06	-	-	54	-14.94	168	256	V

Pk - Peak detector
 Av - Average detection

Note:

- Test was performed @ 3 meter distance.
- Results are reported for 15.209 for the purposes of assessment against draft KDB 680106 for charging at distances greater than 1m

8. AC POWER LINE CONDUCTED EMISSIONS

LIMITS

§ 18.307 For the following equipment, when designed to be connected to the public utility (AC) power line the radio frequency voltage that is conducted back onto the AC power line on any frequency or frequencies shall not exceed the limits in the following table. Compliance with the provisions of this paragraph shall be based on the measurements of the radio frequency voltage between each power line and ground at the power terminal using a 50 μ H/50 ohms line impedance stabilization network (LISN).

§ 18.307 (b) All other Part 18 consumer devices:

Frequency of Emission (MHz)	Conducted Limit (dB μ V)	
	Quasi-peak	Average
0.15-0.5	66 to 56 *	56 to 46 *
0.5-5	56	46
5-30	60	50

*Decreases with the logarithm of the frequency.

TEST PROCEDURE

Tested in accordance with FCC / OST MP-5

RESULTS

8.1. CONFIGURATION 1

LINE 1 RESULTS

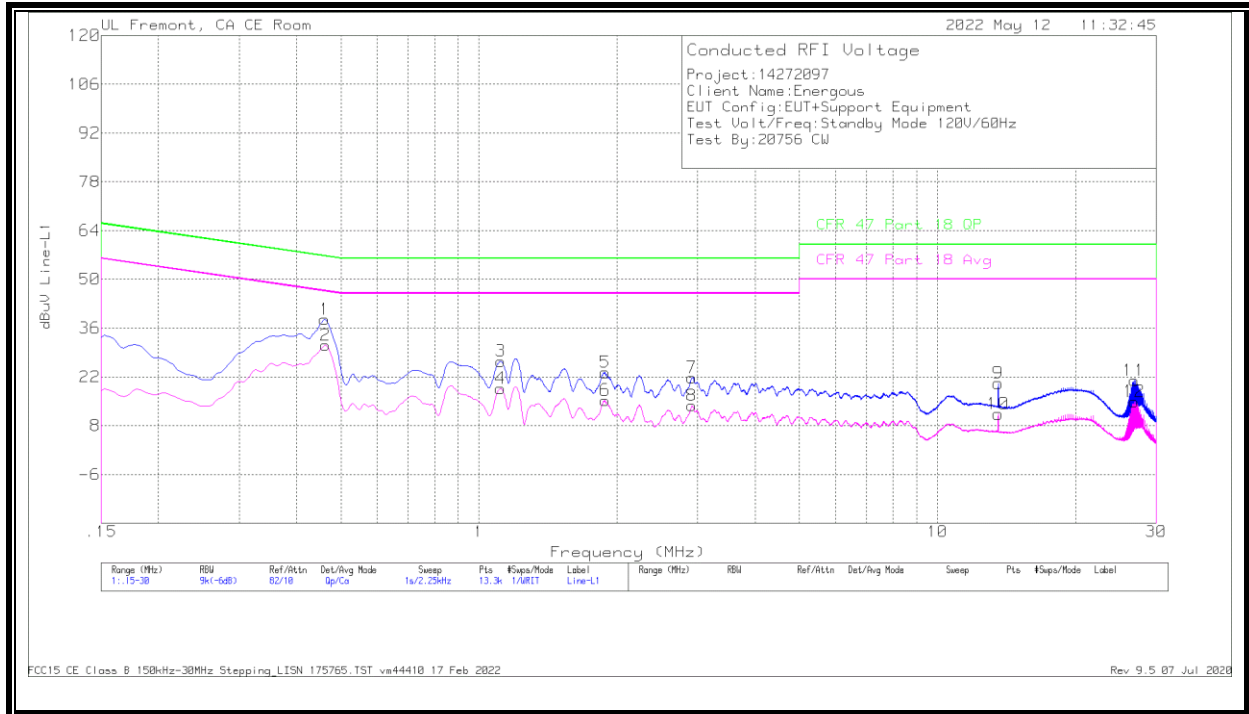

WORST EMISSIONS

Range 1: Line-L1 .15 - 30MHz											
Marker	Frequency (MHz)	Meter Reading (dBuV)	Det	175765 LISN L1	C1&C3 cable	TekBox Limiter TBFL1 207996	Corrected Reading dBuV	CFR 47 Part18 QP	QP Margin (dB)	CFR 47 Part18 Avg	Av(CISPR)M argin (dB)
2	.46275	21.79	Ca	0	0	9.3	31.09	-	-	46.64	-15.55
4	1.11413	9.26	Ca	0	.1	9.3	18.66	-	-	46	-27.34
6	1.8825	5.87	Ca	0	.1	9.3	15.27	-	-	46	-30.73
8	2.913	4.34	Ca	0	.1	9.3	13.74	-	-	46	-32.26
10	13.56	1.77	Ca	.1	.2	9.3	11.37	-	-	50	-38.63
12	26.8665	5	Ca	.2	.3	9.4	14.9	-	-	50	-35.1
1	.4605	29.17	Qp	0	0	9.3	38.47	56.68	-18.21	-	-
3	1.11638	17.11	Qp	0	.1	9.3	26.51	56	-29.49	-	-
5	1.8825	13.88	Qp	0	.1	9.3	23.28	56	-32.72	-	-
7	2.91413	12.35	Qp	0	.1	9.3	21.75	56	-34.25	-	-
9	13.56	10.59	Qp	.1	.2	9.3	20.19	60	-39.81	-	-
11	26.82825	11.09	Qp	.2	.3	9.4	20.99	60	-39.01	-	-

Qp - Quasi-Peak detector

Ca - CISPR average detection

NOTE: Markers 9 and 10, 13.56MHz is an external NFC signal unrelated to the EUT.

LINE 2 RESULTS

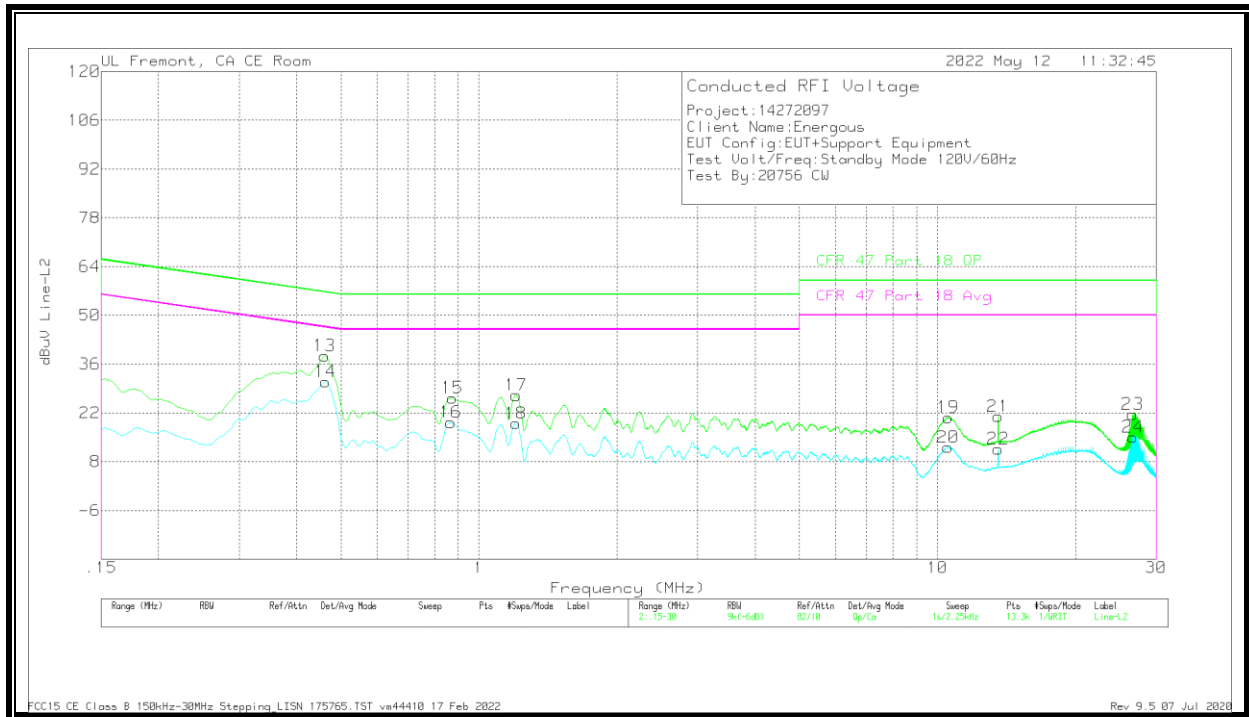

WORST EMISSIONS

Range 2: Line-L2 .15 - 30MHz												
Marker	Frequency (MHz)	Meter Reading (dBuV)	Det	175765 LISN L2	C2&C3 cable	TekBox Limiter TBFL1 207996	Corrected Reading dBuV	CFR 47 Part18 QP	QP Margin (dB)	CFR 47 Part18 Avg	Av(CISPR)M argin (dB)	
14	.46275	21.66	Ca	0	0	9.3	30.96	-	-	46.64	-15.68	
16	.86775	9.89	Ca	0	.1	9.3	19.29	-	-	46	-26.71	
18	1.203	9.61	Ca	0	.1	9.3	19.01	-	-	46	-26.99	
20	10.53825	2.51	Ca	.1	.2	9.3	12.11	-	-	50	-37.89	
22	13.56	2.01	Ca	.1	.2	9.3	11.61	-	-	50	-38.39	
24	26.67525	5.25	Ca	.2	.3	9.3	15.05	-	-	50	-34.95	
13	.4605	29.07	Qp	0	0	9.3	38.37	56.68	-18.31	-	-	
15	.8745	16.86	Qp	0	.1	9.3	26.26	56	-29.74	-	-	
17	1.20525	17.67	Qp	0	.1	9.3	27.07	56	-28.93	-	-	
19	10.54275	11.1	Qp	.1	.2	9.3	20.7	60	-39.3	-	-	
21	13.56	11.38	Qp	.1	.2	9.3	20.98	60	-39.02	-	-	
23	26.63925	11.77	Qp	.2	.3	9.3	21.57	60	-38.43	-	-	

Qp - Quasi-Peak detector

Ca - CISPR average detection

NOTE: Markers 21 and 22, 13.56MHz is an external NFC signal unrelated to the EUT.

8.2. CONFIGURATION 2

LINE 1 RESULTS

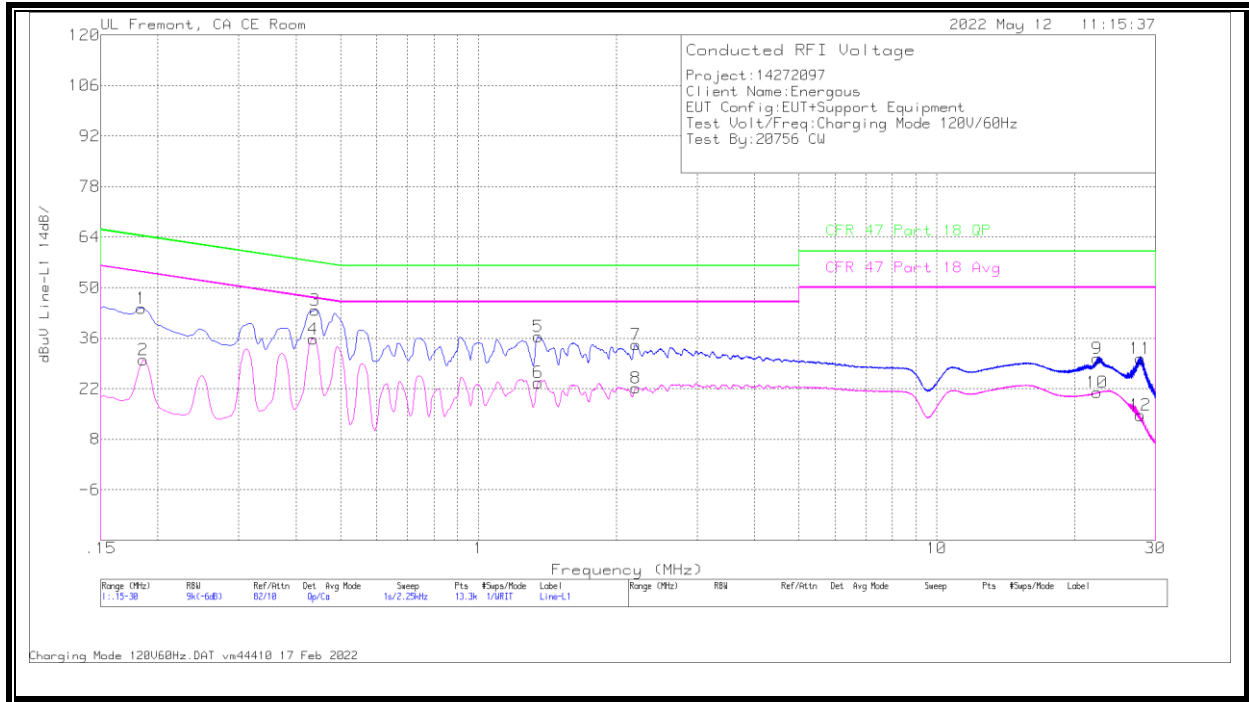

WORST EMISSIONS

Range 1: Line-L1 .15 - 30MHz											
Marker	Frequency (MHz)	Meter Reading (dBuV)	Det	175765 LISN L1	C1&C3 cable	TekBox Limiter TBFL1 207996	Corrected Reading dBuV	CFR 47 Part 18 QP	QP Margin (dB)	CFR 47 Part 18 Avg	Av(CISPR)M argin (dB)
2	.186	20.47	Ca	.1	0	9.4	29.97	-	-	54.21	-24.24
4	.4358	26.49	Ca	0	0	9.3	35.79	-	-	47.14	-11.35
6	1.3515	14.27	Ca	0	.1	9.3	23.67	-	-	46	-22.33
8	2.2088	12.82	Ca	0	.1	9.3	22.22	-	-	46	-23.78
10	22.3778	11.13	Ca	.2	.3	9.3	20.93	-	-	50	-29.07
12	27.8115	4.73	Ca	.2	.3	9.4	14.63	-	-	50	-35.37
1	.1838	34.77	Qp	.1	0	9.4	44.27	64.31	-20.04	-	-
3	.4403	34.41	Qp	0	0	9.3	43.71	57.06	-13.35	-	-
5	1.3515	27.03	Qp	0	.1	9.3	36.43	56	-19.57	-	-
7	2.2088	24.72	Qp	0	.1	9.3	34.12	56	-21.88	-	-
9	22.362	20.5	Qp	.2	.3	9.3	30.3	60	-29.7	-	-
11	27.798	20.48	Qp	.2	.3	9.4	30.38	60	-29.62	-	-

Qp - Quasi-Peak detector
 Ca - CISPR average detection

LINE 2 RESULTS

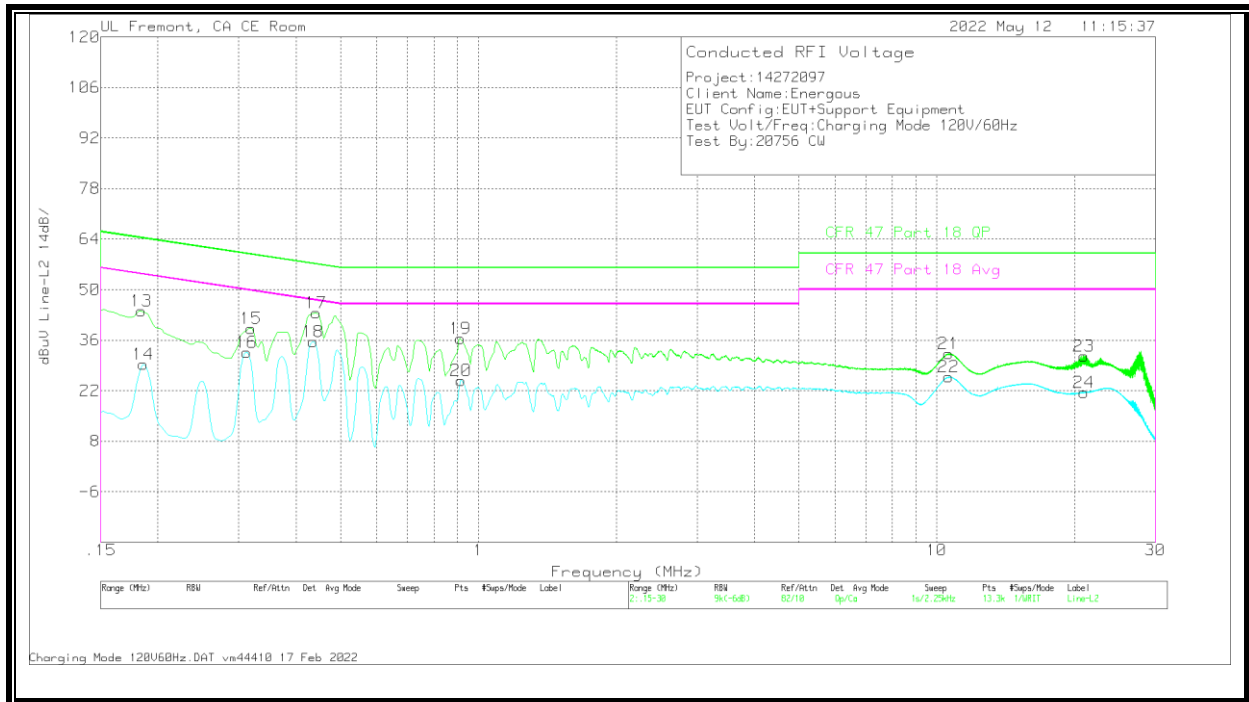

WORST EMISSIONS

Range 2: Line-L2 .15 - 30MHz											
Marker	Frequency (MHz)	Meter Reading (dBuV)	Det	175765 LISN L2	C2&C3 cable	TekBox Limiter TBFL1 207996	Corrected Reading dBuV	CFR 47 Part 18 QP	QP Margin (dB)	CFR 47 Part 18 Avg	Av(CISPR)M argin (dB)
14	.186	19.82	Ca	.1	0	9.4	29.32	-	-	54.21	-24.89
16	.312	23.39	Ca	0	0	9.3	32.69	-	-	49.92	-17.23
18	.4358	26.24	Ca	0	0	9.3	35.54	-	-	47.14	-11.6
20	.9173	15.39	Ca	0	.1	9.3	24.79	-	-	46	-21.21
22	10.6204	16.23	Ca	.1	.2	9.3	25.83	-	-	50	-24.17
24	20.9715	11.86	Ca	.1	.3	9.3	21.56	-	-	50	-28.44
13	.1838	34.58	Qp	.1	0	9.4	44.08	64.31	-20.23	-	-
15	.3188	30	Qp	0	0	9.3	39.3	59.74	-20.44	-	-
17	.4425	34.21	Qp	0	0	9.3	43.51	57.01	-13.5	-	-
19	.9128	26.97	Qp	0	.1	9.3	36.37	56	-19.63	-	-
21	10.6283	22.62	Qp	.1	.2	9.3	32.22	60	-27.78	-	-
23	20.9558	21.93	Qp	.1	.3	9.3	31.63	60	-28.37	-	-

Qp - Quasi-Peak detector
 Ca - CISPR average detection