



TEST REPORT

Report Number. : 14272097-E2V1

Applicant : ENERGOUS CORPORATION
3590 NORTH FIRST STREET,
SUITE 210,
SAN JOSE, CA 95134, U.S.A.

Model : VN-1820

Brand : ENERGOUS

FCC ID : 2ADNG-VN1820

EUT Description : WIRELESS CHARGER

Test Standard(s) : FCC 47 CFR PART 15 SUBPART C

Date Of Issue:

May 27, 2022

Prepared by:

UL VERIFICATION SERVICES

47173 Benicia Street

Fremont, CA 94538 U.S.A.

TEL: (510) 319-4000

FAX: (510) 661-0888



REPORT REVISION HISTORY

Rev.	Issue Date	Revisions	Revised By
V1	5/27/2022	Initial Issue	--

TABLE OF CONTENTS

REPORT REVISION HISTORY	2
TABLE OF CONTENTS	3
1. ATTESTATION OF TEST RESULTS	5
2. TEST RESULTS SUMMARY	7
3. TEST METHODOLOGY	7
4. FACILITIES AND ACCREDITATION	7
5. DECISION RULES AND MEASUREMENT UNCERTAINTY	8
5.1. METROLOGICAL TRACEABILITY	8
5.2. DECISION RULES.....	8
5.3. MEASUREMENT UNCERTAINTY.....	8
5.4. SAMPLE CALCULATION	8
6. EQUIPMENT UNDER TEST	9
6.1. EUT DESCRIPTION	9
6.2. MAXIMUM OUTPUT POWER.....	9
6.3. DESCRIPTION OF AVAILABLE ANTENNAS	9
6.4. SOFTWARE AND FIRMWARE.....	9
6.5. WORST-CASE CONFIGURATION AND MODE.....	10
6.6. DESCRIPTION OF TEST SETUP.....	11
7. MEASUREMENT METHOD.....	14
8. TEST AND MEASUREMENT EQUIPMENT	15
9. ANTENNA PORT TEST RESULTS	16
9.1. ON TIME AND DUTY CYCLE.....	16
9.2. 99% BANDWIDTH.....	17
9.3. 6 dB BANDWIDTH.....	18
9.4. OUTPUT POWER.....	19
9.5. AVERAGE POWER.....	20
9.6. POWER SPECTRAL DENSITY.....	21
9.7. CONDUCTED SPURIOUS EMISSIONS.....	22
10. RADIATED TEST RESULTS	24

10.1.	LIMITS AND PROCEDURE.....	24
10.2.	TRANSMITTER ABOVE 1 GHz.....	26
10.3.	WORST CASE BELOW 30MHZ.....	36
10.4.	WORST CASE BELOW 1 GHZ.....	37
10.5.	WORST CASE 18-26 GHZ.....	39
11.	AC POWER LINE CONDUCTED EMISSIONS	41
12.	SETUP PHOTOS	44

1. ATTESTATION OF TEST RESULTS

COMPANY NAME: ENERGOUS CORPORATION
3590 NORTH FIRST STREET,
SUITE 210,
SAN JOSE, CA 95134, U.S.A

EUT DESCRIPTION: WIRELESS CHARGER

MODEL NUMBER: VN-1820

BRAND: ENERGOUS

SERIAL NUMBER: 3013 (Radiated), 3007 (Conducted)

SAMPLE RECEIPT DATE: MAY 09, 2022

DATE TESTED: MAY 09, 2022– MAY 12, 2022

APPLICABLE STANDARDS	
STANDARD	TEST RESULTS
CFR 47 Part 15 Subpart C	Complies

UL Verification Services Inc. tested the above equipment in accordance with the requirements set forth in the above standards. The test results show that the equipment tested is capable of demonstrating compliance with the requirements as documented in this report.

The results documented in this report apply only to the tested sample, under the conditions and modes of operation as described herein. It is the manufacturer's responsibility to assure that additional production units of this model are manufactured with identical electrical and mechanical components. All samples tested were in good operating condition throughout the entire test program. Measurement Uncertainties are published for informational purposes only and were not taken into account unless noted otherwise.

This document may not be altered or revised in any way unless done so by UL Verification Services Inc. and all revisions are duly noted in the revisions section. Any alteration of this document not carried out by UL Verification Services Inc. will constitute fraud and shall nullify the document. This report must not be used by the client to claim product certification, approval, or endorsement by A2LA, NIST, any agency of the Federal Government, or any agency of the U.S. government.

Approved & Released For
UL Verification Services Inc. By:

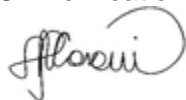

DAN CORONIA
OPERATIONS LEADER
UL Verification Services Inc.

Prepared By:

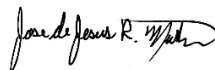

JOSE MARTINEZ
TEST ENGINEER
UL Verification Services Inc.

Reviewed By:



TINA CHU
SENIOR PROJECT ENGINEER
UL Verification Services Inc.

2. TEST RESULTS SUMMARY

This report contains data provided by the customer which can impact the validity of results. UL Verification Services Inc. is only responsible for the validity of results after the integration of the data provided by the customer.

FCC Clause	Requirement	Result	Comment
See Comment	Duty Cycle	Reporting purposes only	ANSI C63.10 Section 11.6.
-	99% OBW	Reporting purposes only	ANSI C63.10 Section 6.9.3.
15.247 (a) (2)	6dB BW	Complies	None.
15.247 (b) (3)	Output Power	Complies	None.
See Comment	Average power	Reporting purposes only	Per ANSI C63.10, Section 11.9.2.3.2.
15.247 (e)	PSD	Complies	None.
15.247 (d)	Conducted Spurious Emissions	Complies	None.
15.209, 15.205	Radiated Emissions	Complies	None.
15.207	AC Mains Conducted Emissions	Complies	None.

3. TEST METHODOLOGY

The tests documented in this report were performed in accordance with FCC CFR 47 Part 2, FCC CFR 47 Part 15, ANSI C63.10-2013, KDB 558074 D01 15.247 Meas Guidance v05r02, KDB 414788 D01 Radiated Test Site v01r01.

4. FACILITIES AND ACCREDITATION

UL Verification Services Inc. is accredited by A2LA, Certificate Number #0751.05, for all testing performed within the scope of this report. Testing was performed at the locations noted below.

	Address	ISED CABID	ISED Company Number	FCC Registration
<input checked="" type="checkbox"/>	Building 1: 47173 Benicia Street, Fremont, CA 94538, USA	US0104	2324A	550739
<input type="checkbox"/>	Building 2: 47266 Benicia Street, Fremont, CA 94538, USA	US0104	22541	550739
<input checked="" type="checkbox"/>	Building 4: 47658 Kato Rd, Fremont, CA 94538, USA	US0104	2324B	550739

5. DECISION RULES AND MEASUREMENT UNCERTAINTY

5.1. METROLOGICAL TRACEABILITY

All test and measuring equipment utilized to perform the tests documented in this report are calibrated on a regular basis, with a maximum time between calibrations of one year or the manufacturers' recommendation, whichever is less, and where applicable is traceable to recognized national standards.

5.2. DECISION RULES

The Decision Rule is based on Simple Acceptance in accordance with ISO Guide 98-4:2012 Clause 8.2. (Measurement uncertainty is not taken into account when stating conformity with a specified requirement.)

5.3. MEASUREMENT UNCERTAINTY

Where relevant, the following measurement uncertainty levels have been estimated for tests performed on the apparatus:

PARAMETER	U _{Lab}
Worst Case Conducted Disturbance, 9KHz to 0.15 MHz	3.78 dB
Worst Case Conducted Disturbance, 0.15 to 30 MHz	3.40 dB
Worst Case Radiated Disturbance, 9KHz to 30 MHz	2.84 dB
Worst Case Radiated Disturbance, 30 to 1000 MHz	6.01 dB
Worst Case Radiated Disturbance, 1000 to 18000 MHz	4.73 dB
Worst Case Radiated Disturbance, 18000 to 26000 MHz	4.51 dB
Worst Case Radiated Disturbance, 26000 to 40000 MHz	5.29 dB

Uncertainty figures are valid to a confidence level of 95%.

5.4. SAMPLE CALCULATION

RADIATED EMISSIONS

Where relevant, the following sample calculation is provided:

$$\text{Field Strength (dBuV/m)} = \text{Measured Voltage (dBuV)} + \text{Antenna Factor (dB/m)} + \text{Cable Loss (dB)} - \text{Preamp Gain (dB)}$$

$$36.5 \text{ dBuV} + 18.7 \text{ dB/m} + 0.6 \text{ dB} - 26.9 \text{ dB} = 28.9 \text{ dBuV/m}$$

MAINS CONDUCTED EMISSIONS

Where relevant, the following sample calculation is provided:

$$\text{Final Voltage (dBuV)} = \text{Measured Voltage (dBuV)} + \text{Cable Loss (dB)} + \text{Limiter Factor (dB)} + \text{LISN Insertion Loss.}$$

$$36.5 \text{ dBuV} + 0 \text{ dB} + 10.1 \text{ dB} + 0 \text{ dB} = 46.6 \text{ dBuV}$$

6. EQUIPMENT UNDER TEST

6.1. EUT DESCRIPTION

The EUT is an over-the-air, distance charging transmitter. Wireless power transfer is only transmitting a continuous carrier wave signal at 917.5 MHz frequency single channel when client device is positioned within the charging zone. The EUT can only charge one client device at a time. The EUT uses BLE to pair with the client device.

This report documents test results of the Bluetooth Low Energy radio portion (EUT only supports BLE 1Mbps) of the wireless charger.

6.2. MAXIMUM OUTPUT POWER

The transmitter has a maximum peak conducted output power as follows:

Frequency Range (MHz)	Mode	Output Power (dBm)	Output Power (mW)
2402 - 2480	BLE	-2.19	0.60

6.3. DESCRIPTION OF AVAILABLE ANTENNAS

The antenna(s) gain and type, as provided by the manufacturer' are as follows:

The radio utilizes an integrated antenna, with a maximum gain of 2dBi.

6.4. SOFTWARE AND FIRMWARE

The firmware installed in the EUT during testing was Version: plt_fw_683_flash

6.5. WORST-CASE CONFIGURATION AND MODE

Radiated band edge, harmonics, and spurious emissions from 1 GHz to 18GHz were performed with the EUT was set to transmit at the Low/Middle/High channels.

Radiated emission below 30MHz, below 1GHz, above 18GHz, and power line conducted emission were performed with the EUT was set to transmit at the channel with highest output power as worst-case scenario.

The EUT is a tabletop device and it has two ports, one is the power barrel connector jack for power only, second port is a micro USB port for command line interface control, end user will not have access to it. Therefore, all final radiated testing was performed with the EUT in tabletop orientation powered by AC/DC adapter via cable.

Worst-case data rate as provided by the client was:
BLE: 1 Mbps.

BLE and WPT bands operate simultaneously, simultaneous operation results are documented in UL document 14272097-E1 WPT report.

6.6. DESCRIPTION OF TEST SETUP

SUPPORT TEST EQUIPMENT						
Description	Manufacturer	Model	Serial Number	FCC ID/ DoC		
EUT AC/DC Adapter (50 W)	XP Power	VEC50US24	E20122202-4M-0011-2105	DoC		
Laptop	Dell	Precision M3800	3F94RC2	DoC		
Laptop AC/DC adapter	Dell	OV363H	CN-0V363H-CH200-84A-073S-A01	DoC		
I/O CABLES (RF CONDUCTED TEST)						
Cable No.	Port	# of Identical Ports	Connector Type	Cable Type	Cable Length (m)	Remarks
1	AC	1	AC	Un-shielded	1	AC Mains to AC/DC Adapter
2	DC	1	DC	Un-shielded	1.5	AC/DC Adapter to Laptop
3	USB	1	UART	Un-shielded	1.5	EUT to Laptop
4	Antenna	1	SMA	Un-shielded	1.1	To spectrum analyzer
5	AC	1	AC	Un-shielded	1.8	AC Mains to AC/DC Adapter
6	DC	1	Power Barrel Connector Jack	Un-shielded	1.5	AC/DC Adapter to EUT
I/O CABLES (RF RADIATED TEST/AC POWER LINE TEST)						
Cable No.	Port	# of Identical Ports	Connector Type	Cable Type	Cable Length (m)	Remarks
1	AC	1	AC	Un-shielded	1.8	AC Mains to AC/DC Adapter
2	DC	1	Power Barrel Connector Jack	Un-shielded	1.5	AC/DC Adapter to EUT

TEST SETUP-CONDUCTED TEST

The EUT was connected to the test laptop via cable. Test software exercised the EUT.

SETUP DIAGRAM

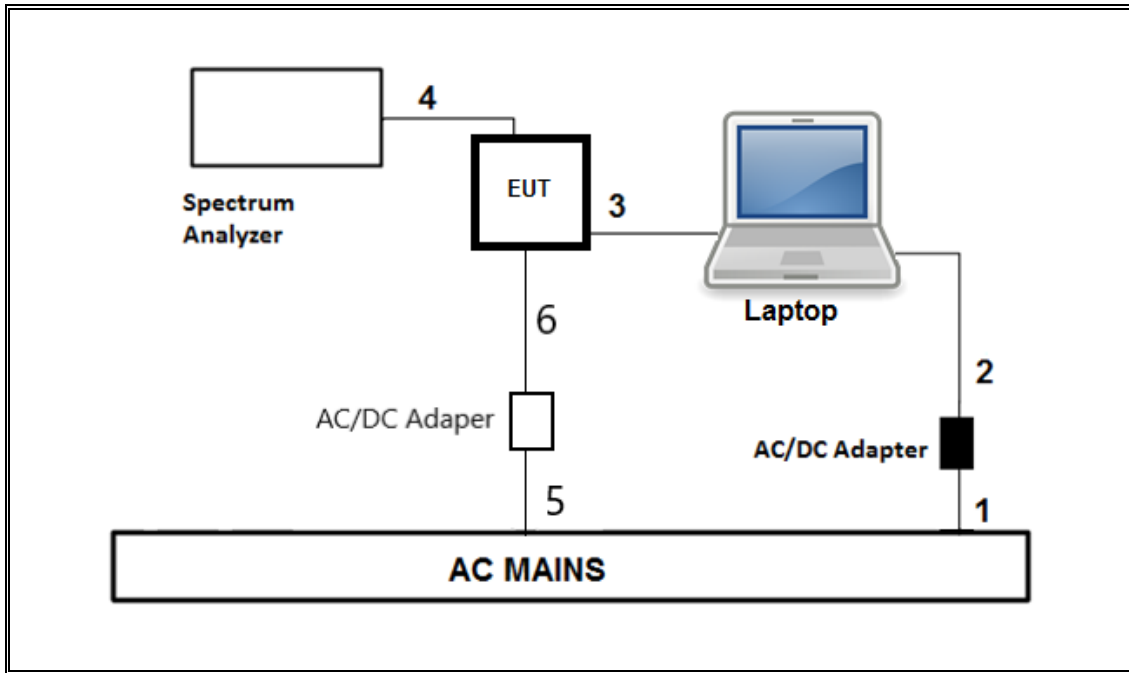

TEST SETUP- RADIATED TEST / AC LINE CONDUCTED TEST

The EUT was powered by an AC/DC adapter via cable. Test software exercised the EUT. Laptop was removed during the test.

SETUP DIAGRAM

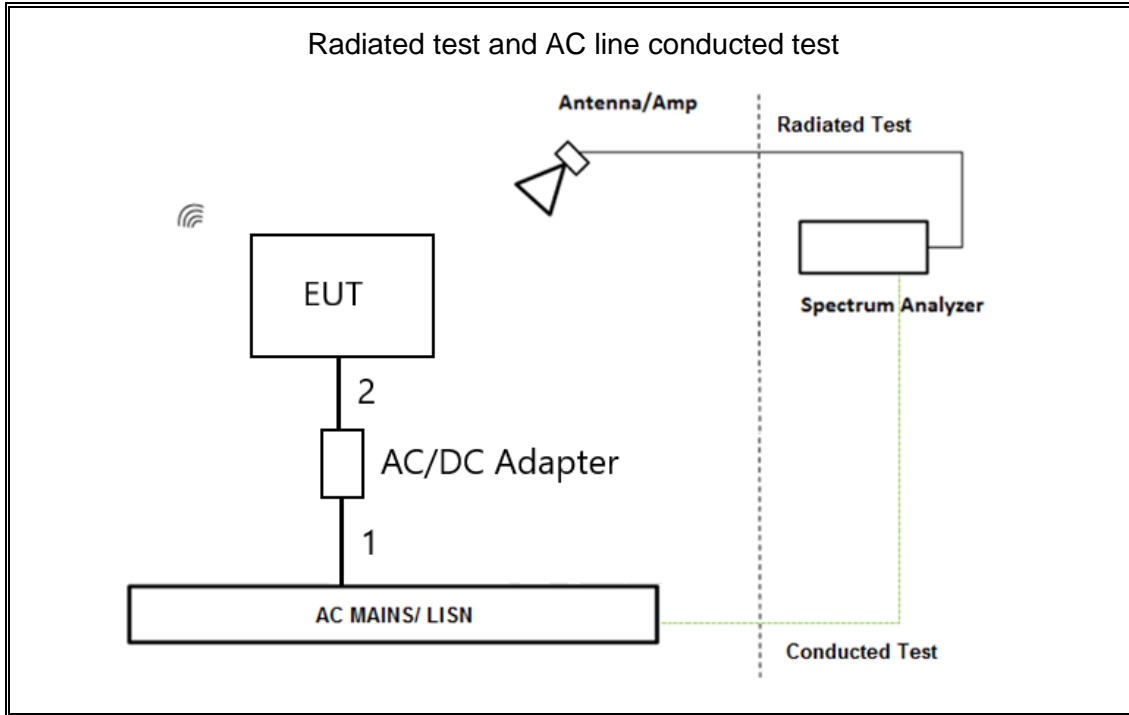

7. MEASUREMENT METHOD

6 dB BW: ANSI C63.10 Subclause -11.8.1

Occupied BW (99%): ANSI C63.10-2013 Section 6.9.3

Output Power: ANSI C63.10 Subclause -11.9.1.3 Method PKPM1 Peak-reading power meter
Output Power: ANSI C63.10 Subclause -11.9.2.3.2 Method AVGPM-G (Measurement using a gated RF average-reading power meter)

PSD: ANSI C63.10 Subclause -11.10.2 Method PKPSD (peak PSD)

Radiated emissions non-restricted frequency bands: ANSI C63.10 Subclause -11.11

Radiated emissions restricted frequency bands: ANSI C63.10 Subclause -11.12.1

Conducted emissions in restricted frequency bands: ANSI C63.10 Subclause -11.12.2

Band-edge: ANSI C63.10 Subclause -11.13.3.4 Integration method -Trace averaging across ON and OFF times DC correction

AC Power Line Conducted Emissions: ANSI C63.10-2013, Section 6.2.

Radiated Spurious Emissions Below 30MHz: ANSI C63.10-2013 Section 6.4

8. TEST AND MEASUREMENT EQUIPMENT

The following test and measurement equipment was utilized for the tests documented in this report:

TEST EQUIPMENT LIST				
Description	Manufacturer	Model	Asset	Cal Due
Antenna, Passive Loop 30Hz - 1MHz	ELECTRO METRICS	EM-6871	SC-8015	05/24/2022
Antenna, Passive Loop 100KHz - 30MHz	ELECTRO METRICS	EM-6872	SC-8014	05/24/2022
Antenna, Horn 1-18GHz	ETS-Lindgren	3117	80404	08/04/2022
RF Filter Box, 8 port, 1-18GHz	UL-FR1 (CTECH)	SAC 8 port rf box 1	197920	04/19/2023
Antenna, Broadband Hybrid, 30MHz to 2GHz	Sunol Sciences Corp.	JB1	82258	10/01/2022
Amplifier, 9KHz to 1GHz, 32dB	SONOMA INSTRUMENT	310	175953	02/08/2023
EMI TEST RECEIVER	Rohde & Schwarz	ESW44	169927	02/16/2023
Antenna, Horn 18 to 26.5GHz	ARA	MWH-1826/B	172363	12/07/2022
Amplifier 18-26.5GHz	AMPLICAL	AMP18G26.5-60	171583	01/27/2023
Spectrum Analyzer, PSA, 3Hz to 26.5GHz	Keysight Technologies Inc	E4440A	80386	02/02/2023
Power Meter, P-series single channel	Keysight Technologies Inc	N1911A	90733	01/24/2023
Power Sensor, P - series, 50MHz to 18GHz, Wideband	Keysight Technologies Inc	N1921A	90388	01/24/2023
AC Line Conducted				
Description	Manufacturer	Model	ID Num	Cal Due
LISN	Fischer Custom Communications, Inc	FCC-LISN-50/250-25-2-01-480V	175765	01/26/2023
EMI TEST RECEIVER	Rohde & Schwarz	ESR	93091	02/21/2023
Transient Limiter	TE	TBFL1	207996	06/01/2022
UL AUTOMATION SOFTWARE				
Radiated Software	UL	UL EMC	Rev 9.5, Jan 03, 2020	
Antenna Port Software	UL	UL RF	Ver 2021.08.27	
AC Line Conducted Software	UL	UL EMC	Rev 9.5, 07 Jul 2020	

9. ANTENNA PORT TEST RESULTS

9.1. ON TIME AND DUTY CYCLE

LIMITS

None; for reporting purposes only.

PROCEDURE

KDB 558074 Zero-Span Spectrum Analyzer Method.

ON TIME AND DUTY CYCLE RESULTS

Test Engineer: 20756 CW

Mode	ON Time B (msec)	Period (msec)	Duty Cycle x (linear)	Duty Cycle (%)	Duty Cycle Correction Factor (dB)	1/B Minimum VBW (kHz)
2.4GHz Band						
BLE	0.393	0.624	0.629	62.93	2.01	2.546

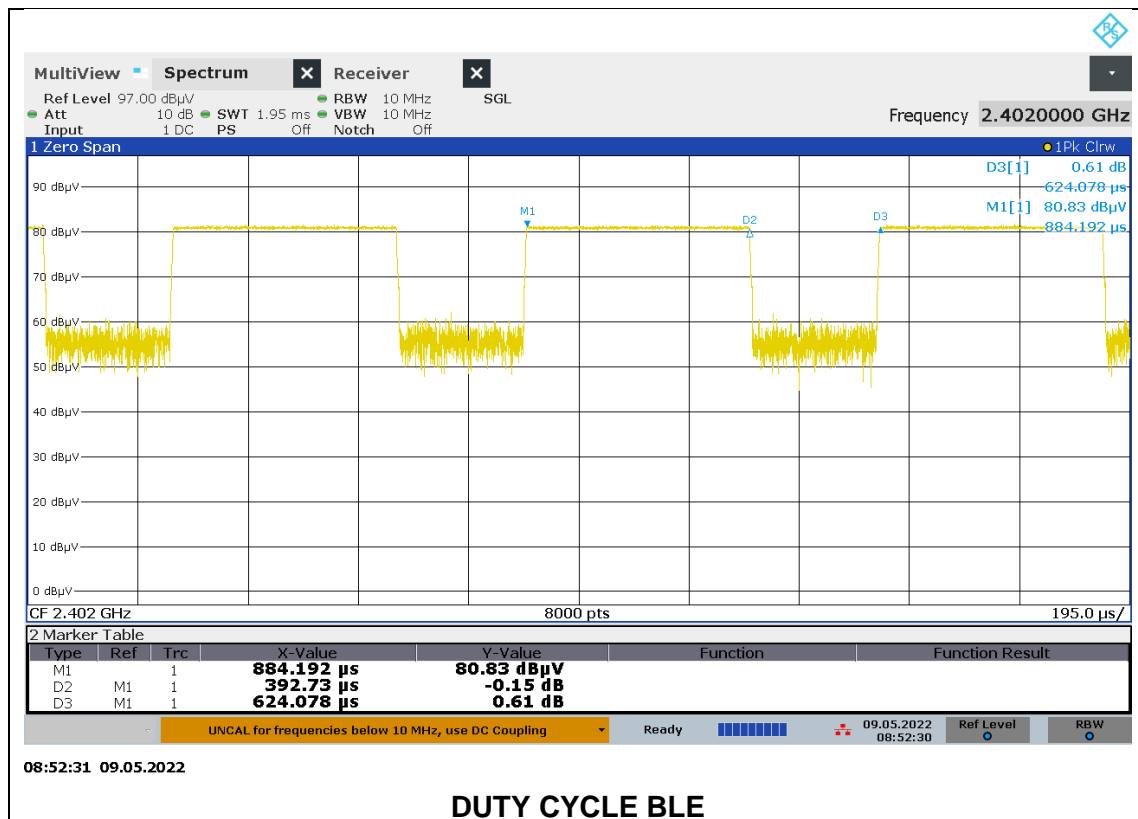

9.2. 99% BANDWIDTH

LIMITS

None; for reporting purposes only.

RESULTS

Channel	Frequency (MHz)	99% Bandwidth (MHz)
Low	2402	1.0379
Middle	2440	1.0370
High	2480	1.0340

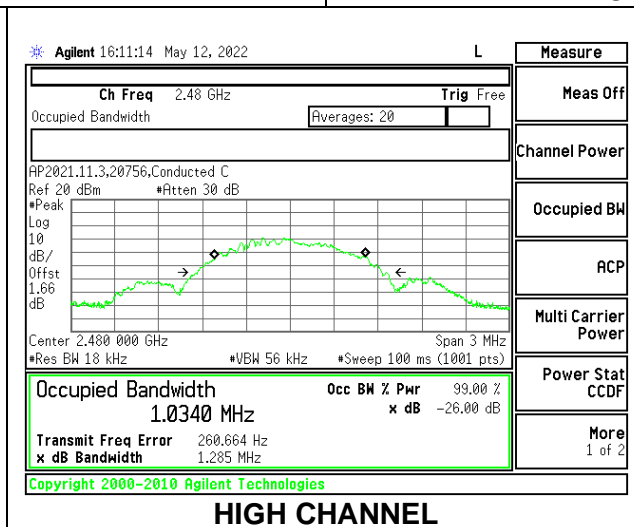
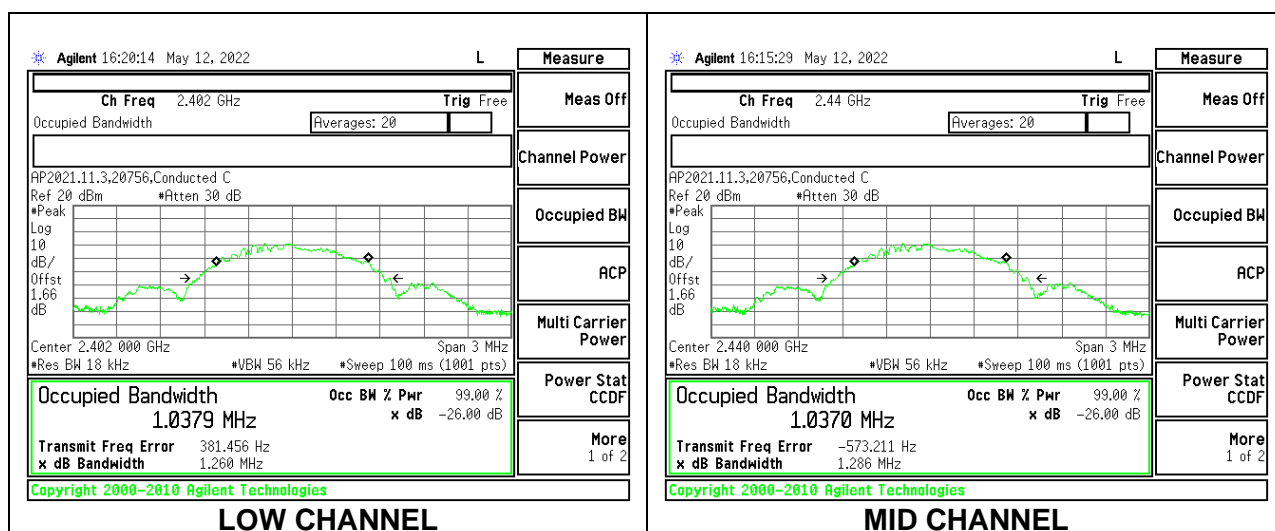

9.3. 6 dB BANDWIDTH

LIMITS

FCC §15.247 (a) (2)

The minimum 6 dB bandwidth shall be at least 500 kHz.

RESULTS

Channel	Frequency (MHz)	6 dB Bandwidth (MHz)	Minimum Limit (MHz)
Low	2402	0.657	0.5
Middle	2440	0.645	0.5
High	2480	0.645	0.5

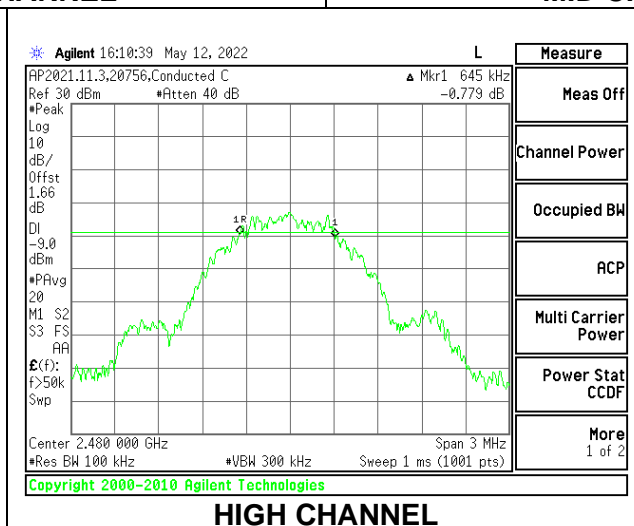
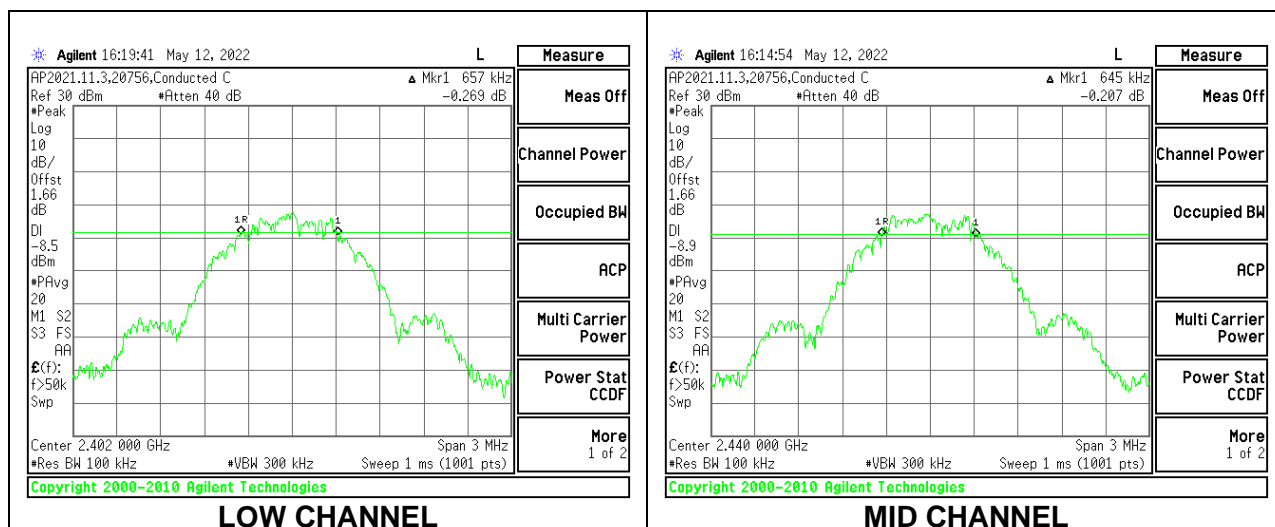

9.4. OUTPUT POWER

LIMITS

FCC §15.247 (b) (3)

The maximum antenna gain is less than or equal to 6 dBi, therefore the limit is 30 dBm.

TEST PROCEDURE

The transmitter output is connected to a power meter.

The power output was measured on the EUT antenna port using SMA cable with 10dB attenuator connected to a power meter via wideband power sensor. Peak output power was read directly from power meter.

RESULTS

Tested By:	20756 CW
Date:	5/12/2022

Channel	Frequency (MHz)	Peak Power Reading (dBm)	Limit (dBm)	Margin (dB)
Low	2402	-2.190	30	-32.190
Middle	2440	-2.350	30	-32.350
High	2480	-2.590	30	-32.590

9.5. AVERAGE POWER

LIMITS

None; for reporting purposes only.

TEST PROCEDURE

The transmitter output is connected to a power meter.

The power output was measured on the EUT antenna port using SMA cable with 10dB attenuator connected to a power meter via wideband power sensor. Gated average output power was read directly from power meter.

RESULTS

Tested By:	20756 CW
Date:	5/12/2022

Channel	Frequency (MHz)	AV power (dBm)
Low	2402	-2.27
Middle	2440	-2.46
High	2480	-2.66

9.6. POWER SPECTRAL DENSITY

LIMITS

FCC §15.247 (e)

The power spectral density conducted from the transmitter to the antenna shall not be greater than 8 dBm in any 3 kHz band during any time interval of continuous transmission.

RESULTS

Channel	Frequency (MHz)	PSD (dBm/3kHz)	Limit (dBm/3kHz)	Margin (dB)
Low	2402	-17.106	8	-25.11
Middle	2440	-17.083	8	-25.08
High	2480	-17.598	8	-25.60

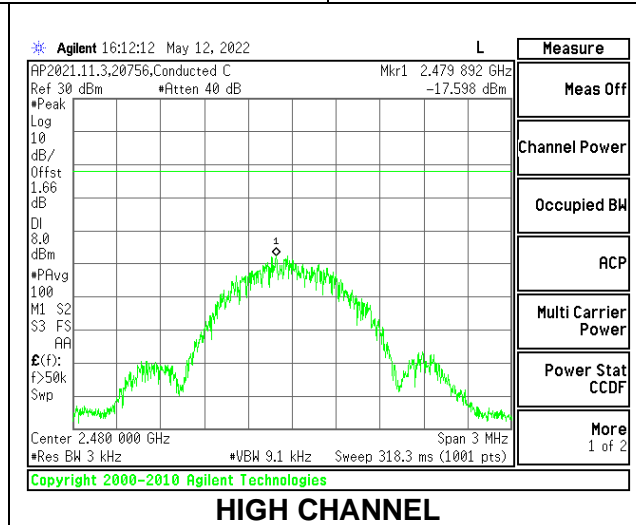
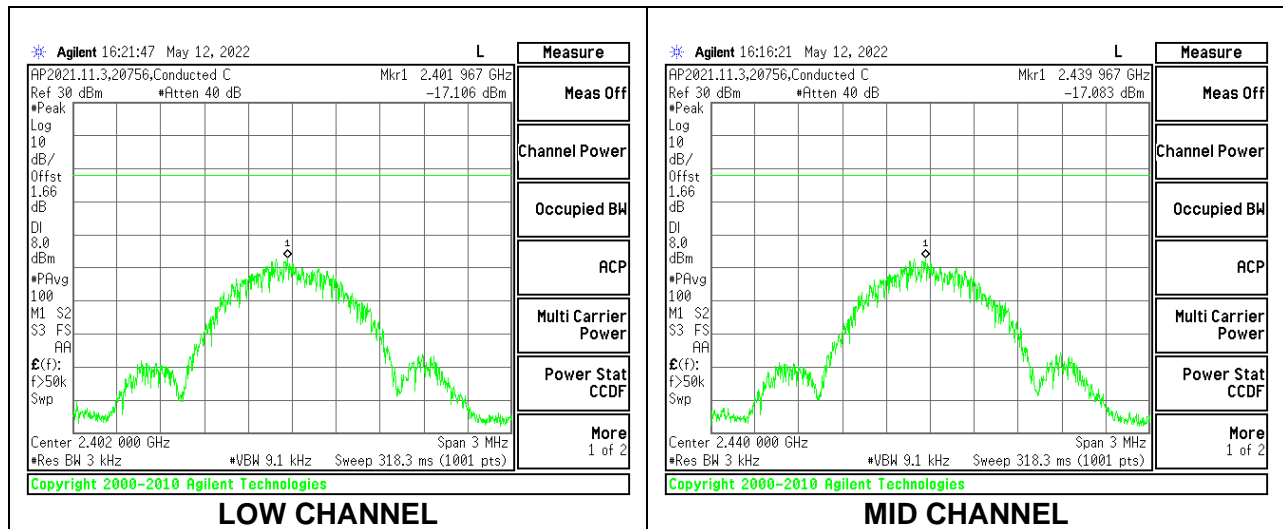

9.7. CONDUCTED SPURIOUS EMISSIONS

LIMITS

FCC §15.247 (d)

Output power was measured based on the use of a peak measurement, therefore the required attenuation is 20 dBc.

RESULTS

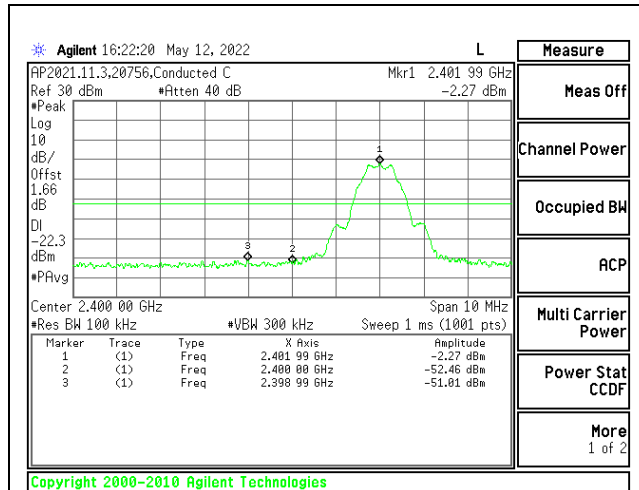

LOW CHANNEL BANDEDGE

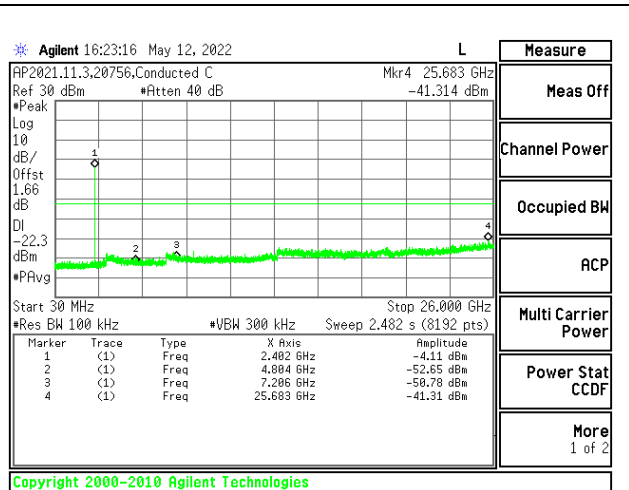

OUT-OF-BAND LOW CHANNEL

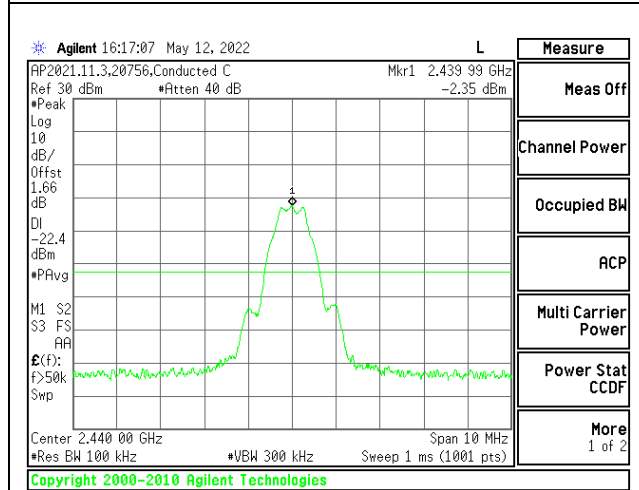

IN-BAND REFERENCE LEVEL

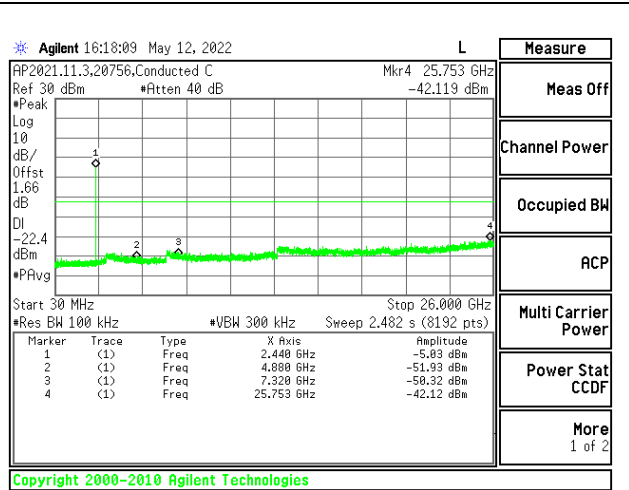

OUT-OF-BAND MID CHANNEL

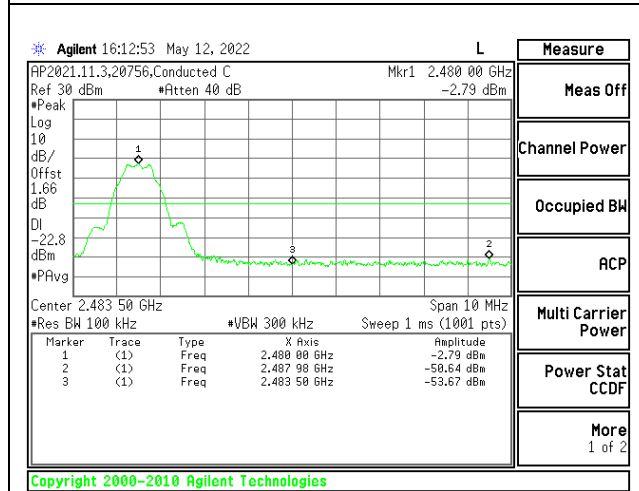

HIGH CHANNEL BANDEDGE

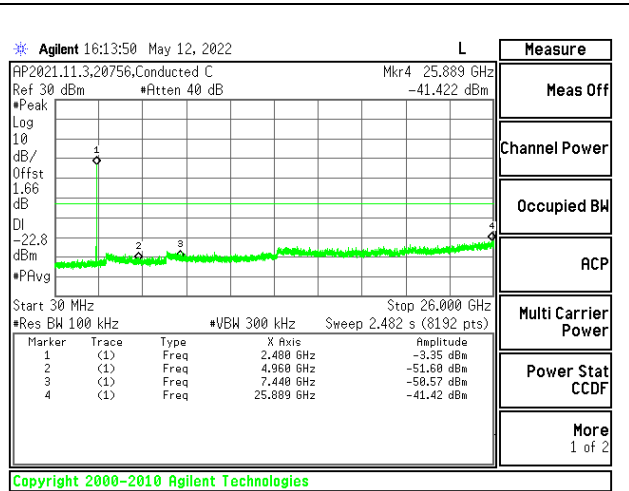

OUT-OF-BAND HIGH CHANNEL

10. RADIATED TEST RESULTS

10.1. LIMITS AND PROCEDURE

LIMITS

FCC §15.205 and §15.209

Frequency Range (MHz)	Field Strength Limit (uV/m) at 3 m	Field Strength Limit (dBuV/m) at 3 m
0.009-0.490	2400/F(kHz) @ 300 m	-
0.490-1.705	24000/F(kHz) @ 30 m	-
1.705 - 30	30 @ 30m	-
30 - 88	100	40
88 - 216	150	43.5
216 - 960	200	46
Above 960	500	54

TEST PROCEDURE

The EUT is placed on a non-conducting table 80 cm above the ground plane for measurement below 1GHz; 1.5 m above the ground plane for measurement above 1GHz. The antenna to EUT distance is 3 meters. The EUT is configured in accordance with ANSI C63.10. The EUT is set to transmit in a continuous mode.

For measurements below 1 GHz the resolution bandwidth is set to 100 kHz for peak detection measurements or 120 kHz for quasi-peak detection measurements in the 30-1000MHz range, 9kHz for peak and/or quasi-peak detection measurements in the 0.15-30MHz range and 200Hz for peak and/or quasi-peak detection measurements in the 9 to 150kHz range. Peak detection is used unless otherwise noted as quasi-peak or average (9-90kHz and 110-490kHz).

For pre-scans above 1 GHz the resolution bandwidth is set to 1 MHz; the video bandwidth is set to 30 KHz for peak measurements.

For final measurements above 1 GHz the resolution bandwidth is set to 1 MHz; the video bandwidth is set to 3 MHz for peak measurements and as applicable for average measurements.

The spectrum from 1 GHz to 18 GHz is investigated with the transmitter set to the lowest, middle, and highest channels in each applicable band. Below 1GHz and above 18GHz emissions, the channel with the highest output power was tested.

The frequency range of interest is monitored at a fixed antenna height and EUT azimuth. The EUT is rotated through 360 degrees to maximize emissions received. The antenna is scanned from 1 to 4 meters above the ground plane to further maximize the emission. Measurements are made with the antenna polarized in both the vertical and the horizontal positions.

For below 30MHz testing, investigation was done on three antenna orientations (parallel, perpendicular, and ground-parallel), parallel and perpendicular are the worst orientations, therefore testing was performed on these two orientations only. Blue color trace on plots: Parallel orientation. Green color trace on plots: Perpendicular orientation.

Base on FCC 15.31 (f) (2): measurements may be performed at a distance closer than that specified in the regulations; however, an attempt should be made to avoid making measurements in the near field.

KDB 414788 Open Field Site(OFS) and Chamber Correlation Justification

OFS and chamber correlation testing had been performed and chamber measured test result is the worst case test result.

10.2. TRANSMITTER ABOVE 1 GHz

BANDEDGE (LOW CHANNEL)

HORIZONTAL RESULT

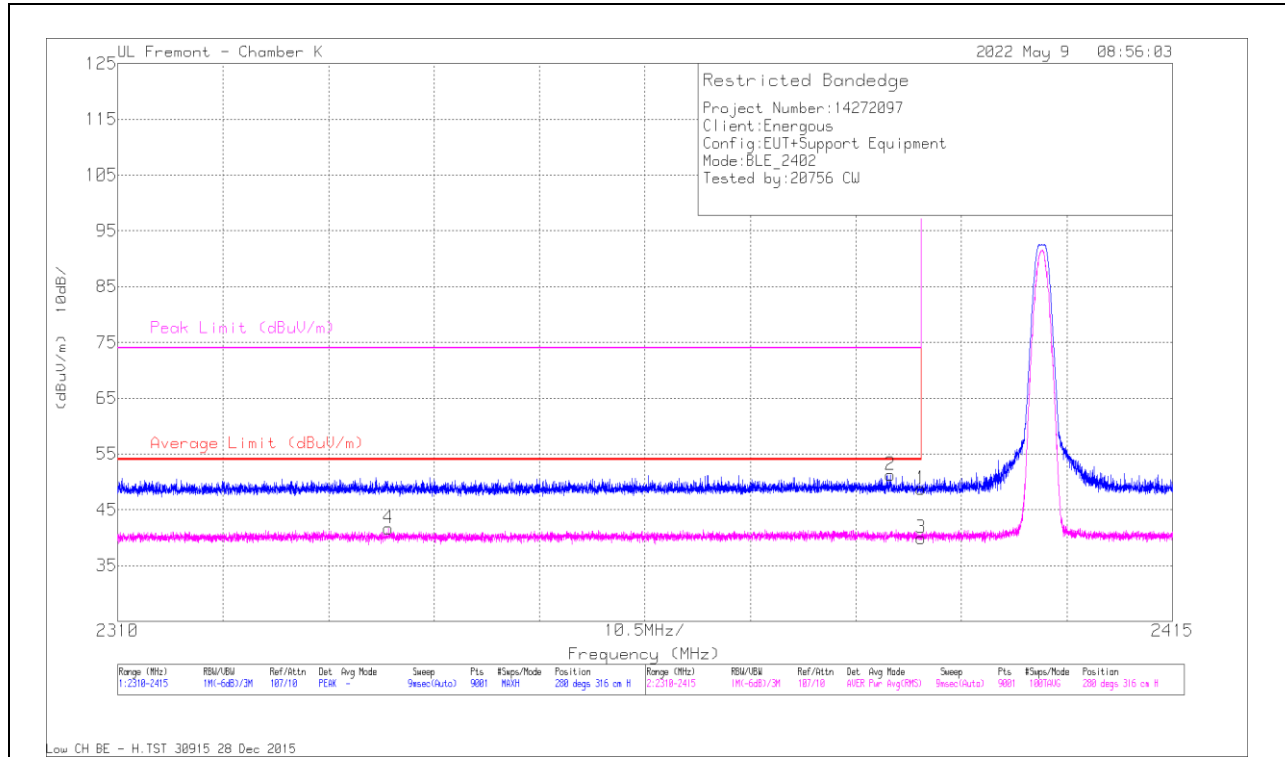

Marker	Frequency (MHz)	Meter Reading (dBuV)	Det	AF 80404 (dBm)	Amp/ChnPad (dB)	DC Corr (dB)	Corrected Reading (dBuV/m)	Average Limit (dBuV/m)	Margin (dB)	Peak Limit (dBuV/m)	PK Margin (dB)	Asimuth (Degs)	Height (cm)	Polarity
1	* 2390	51.05	Pk	32.1	-34.4	0	48.72	-	-	74	-25.22	280	316	H
2	* 2386.909	53.52	Pk	32.1	-34.4	0	51.22	-	-	74	-22.78	280	316	H
3	* 2390	40.25	RMS	32.1	-34.4	2.01	39.96	54	-14.04	-	-	280	316	H
4	* 2336.986	42.22	RMS	32	-34.6	2.01	41.63	54	-12.37	-	-	280	316	H

* - indicates frequency in CFR47 Pt 15
 Pk - Peak detector
 RMS - RMS detection

VERTICAL RESULT

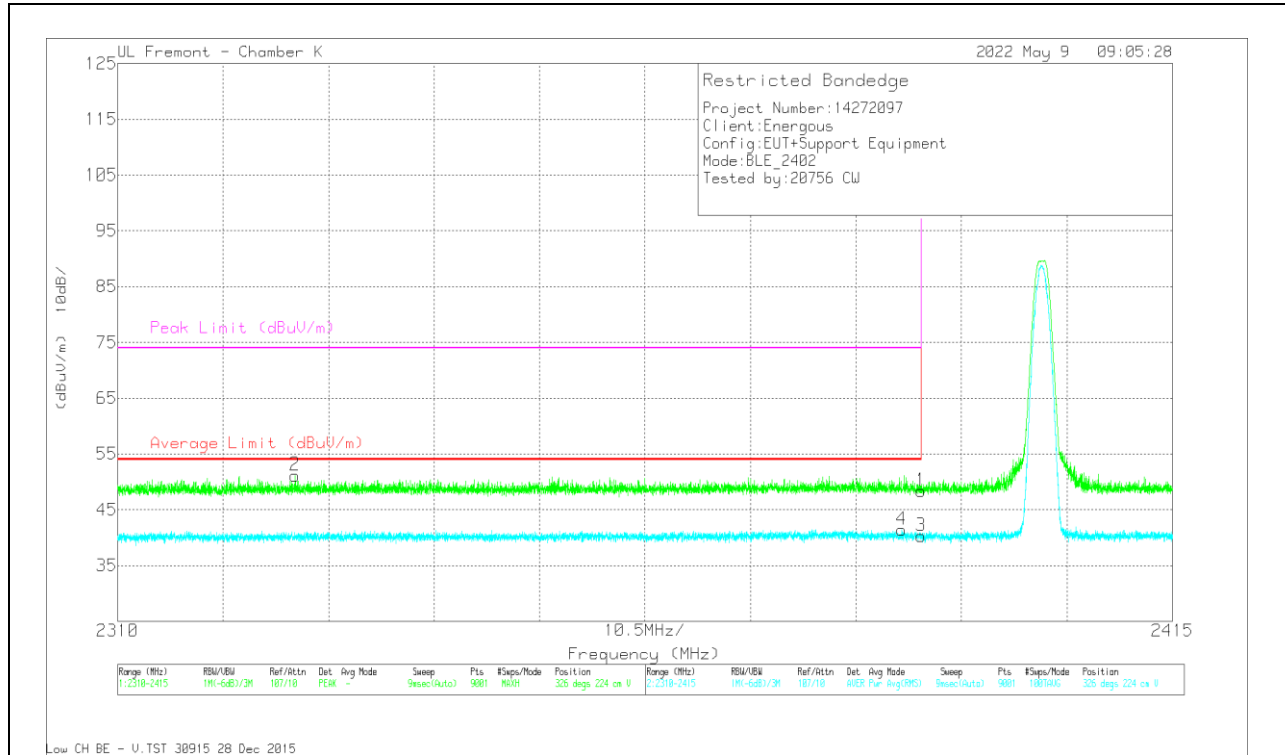

Marker	Frequency (MHz)	Meter Reading (dBuV)	Det	AF 80484 (dBm)	Amp/Ch/Pad (dB)	DC Corr (dB)	Corrected Reading (dBuV/m)	Average Limit (dBuV/m)	Margin (dB)	Peak Limit (dBuV/m)	PK Margin (dB)	Azimuth (Degs)	Height (cm)	Polarity
1	* 2390	50.67	Pk	32.1	-34.4	0	48.37	-	-	74	-25.63	326	224	V
2	* 2327.687	53.99	Pk	31.9	-34.7	0	51.19	-	-	74	-22.81	326	224	V
3	* 2390	40.57	RMS	32.1	-34.4	2.01	40.28	54	-13.72	-	-	326	224	V
4	* 2388.076	41.69	RMS	32.1	-34.4	2.01	41.4	54	-12.6	-	-	326	224	V

* - indicates frequency in CFR47 Pt 15
 Pk - Peak detector
 RMS - RMS detection

BANDEGE (HIGH CHANNEL)

HORIZONTAL RESULT

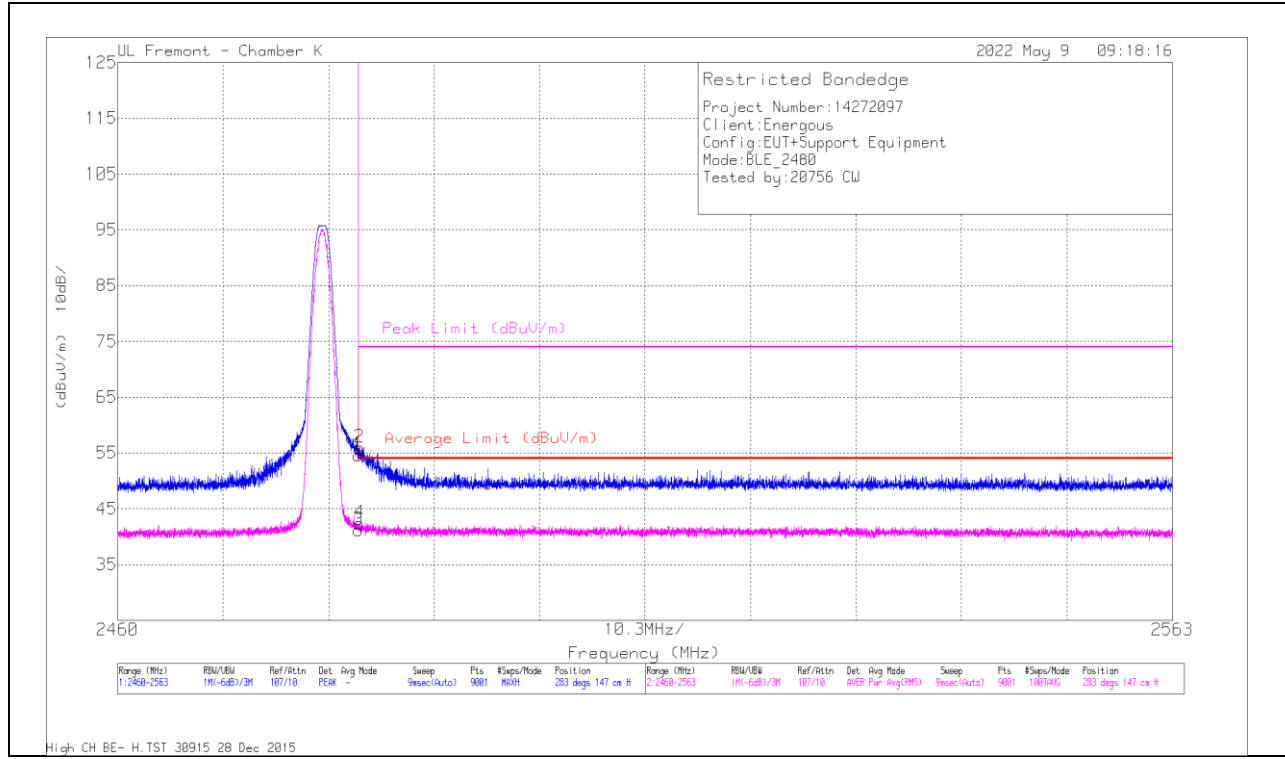

Marker	Frequency (MHz)	Meas Reading (dBuV)	Det	AF 80404 (dBm)	Amp/CM/Pad (dB)	DC Corr (dB)	Corrected Reading (dBuV/m)	Average Limit (dBuV/m)	Margin (dB)	Peak Limit (dBuV/m)	PK Margin (dB)	Azimuth (Degs)	Height (cm)	Polarity
1	*2483.5	55.97	Pk	32.7	-34	0	54.67	-	-	74	-19.33	283	147	H
2	*2483.632	57.24	Pk	32.7	-34	0	55.94	-	-	74	-18.06	283	147	H
3	*2483.5	40.45	RMS	32.7	-34	2.01	41.16	54	-12.84	-	-	283	147	H
4	*2483.62	41.76	RMS	32.7	-34	2.01	42.47	54	-11.53	-	-	283	147	H

* - indicates frequency in CFR47 Pt 15
 Pk - Peak detector
 RMS - RMS detection

VERTICAL RESULT

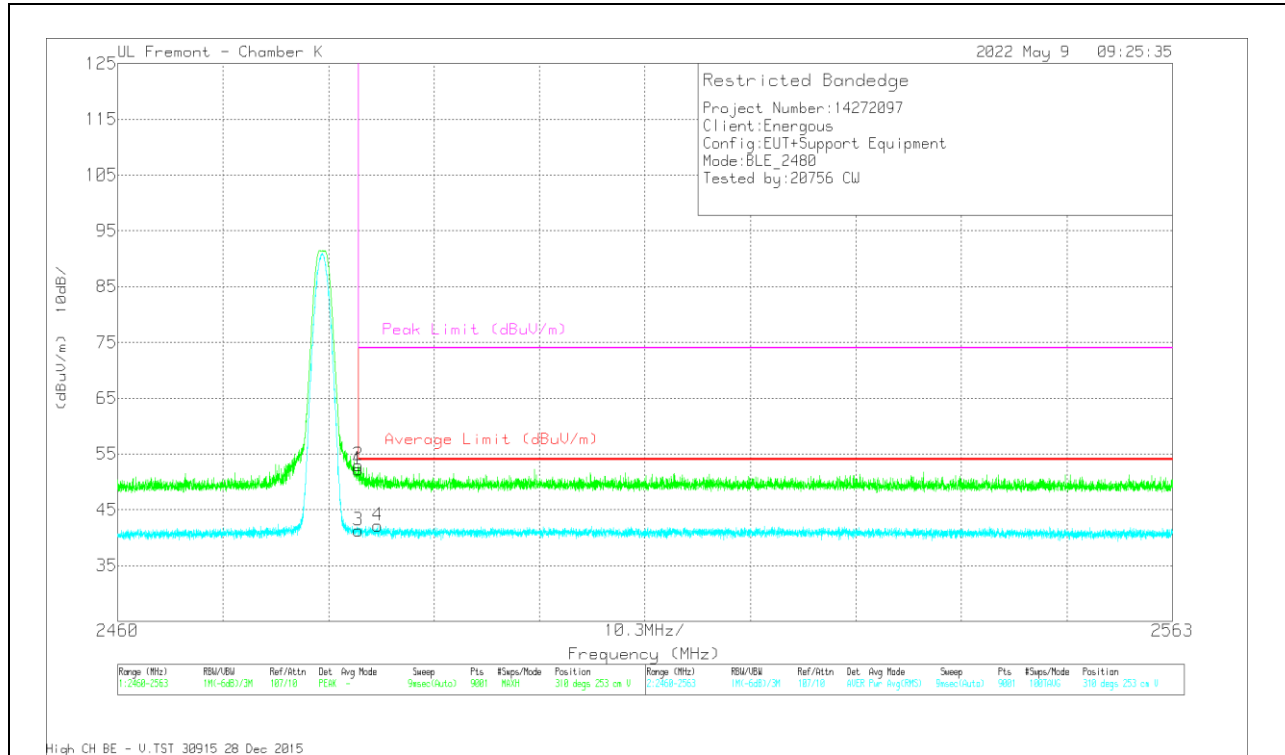

Marker	Frequency (MHz)	Meter Reading (dBuV)	Det	AF 80484 (dBm)	Amp/Ch/Pad (dB)	DC Corr (dB)	Corrected Reading (dBuV/m)	Average Limit (dBuV/m)	Margin (dB)	Peak Limit (dBuV/m)	PK Margin (dB)	Azimuth (Degs)	Height (cm)	Polarity
1	* 2483.5	53.52	Pk	32.7	-34	0	52.22	-	-	74	-21.78	310	253	V
2	* 2483.506	54.26	Pk	32.7	-34	0	52.96	-	-	74	-21.04	310	253	V
3	* 2483.5	40.61	RMS	32.7	-34	2.01	41.32	54	-12.68	-	-	310	253	V
4	* 2485.394	41.4	RMS	32.7	-34	2.01	42.11	54	-11.89	-	-	310	253	V

* - indicates frequency in CFR47 Pt 15
 Pk - Peak detector
 RMS - RMS detection

HARMONICS AND SPURIOUS EMISSIONS

LOW CHANNEL RESULTS

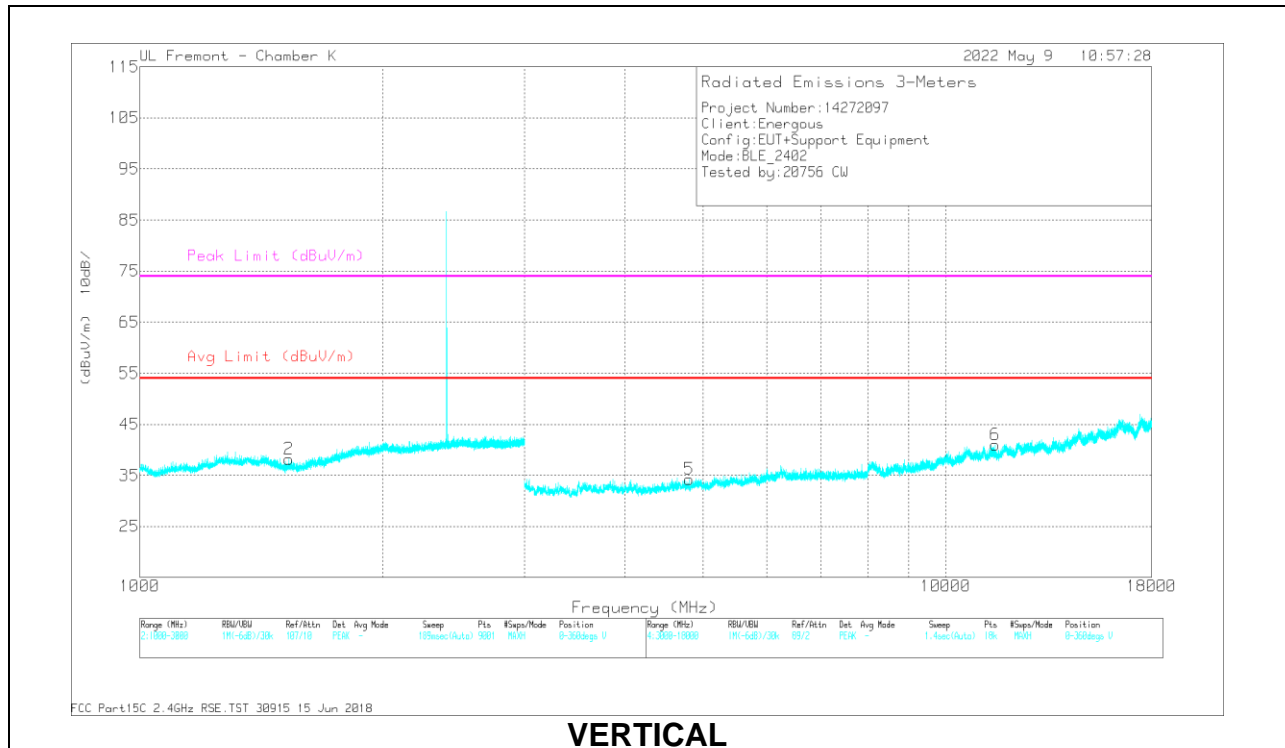
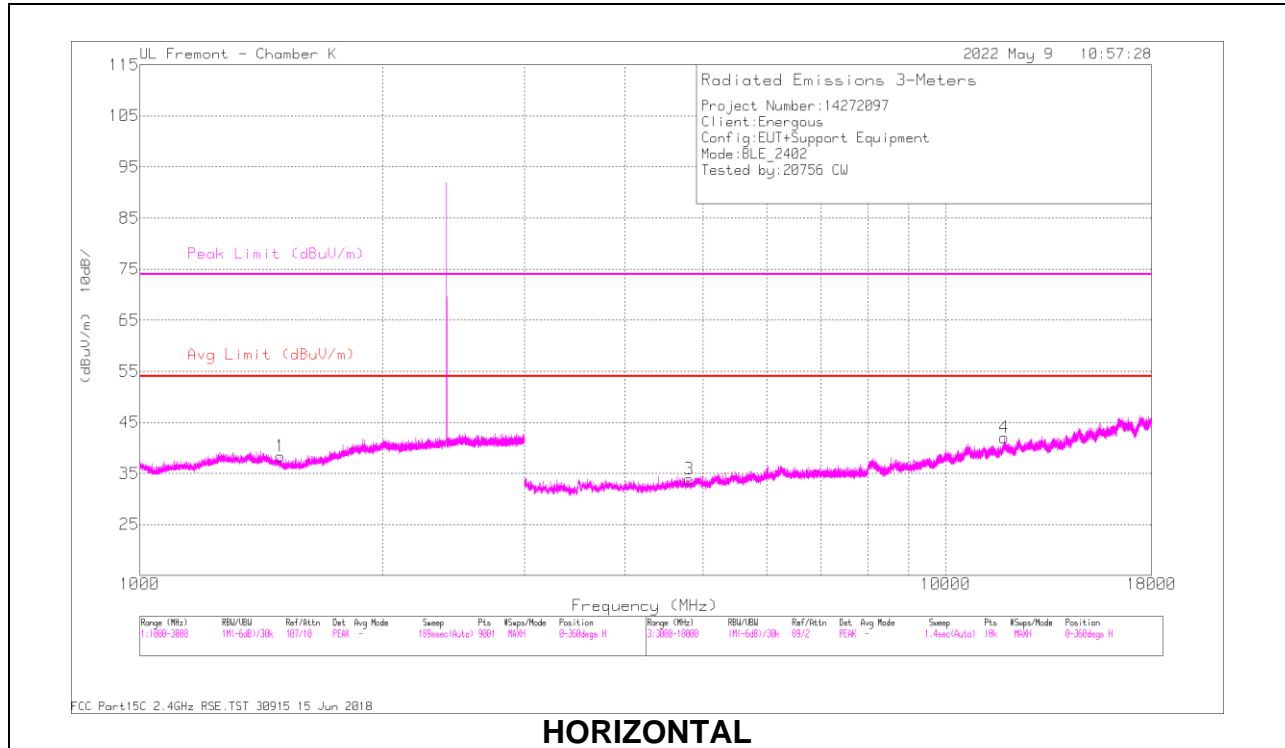

RADIATED EMISSIONS

Marker	Frequency (MHz)	Meter Reading (dBuV)	Det	AF 80404 (dB/m)	Amp/Cbl/Pad (dB)	DC Corr (dB)	Corrected Reading (dBuV/m)	Avg Limit (dBuV/m)	Margin (dB)	Peak Limit (dBuV/m)	PK Margin (dB)	Azimuth (Degs)	Height (cm)	Polarity
1	* 1493.335	55.28	PK2	28.2	-36	0	47.48	-	-	74	-26.52	11	211	H
	* 1493.447	43.61	MAv1	28.2	-36	2.01	37.82	54	-16.18	-	-	11	211	H
2	* 1532.6	55.56	PK2	28	-36	0	47.56	-	-	74	-26.44	262	203	V
	* 1532.08	43.51	MAv1	28	-36	2.01	37.52	54	-16.48	-	-	262	203	V
3	* 4804.312	49.66	PK2	34.2	-39.8	0	44.06	-	-	74	-29.94	306	200	H
	* 4804.216	38.56	MAv1	34.2	-39.8	2.01	34.97	54	-19.03	-	-	306	200	H
4	* 11813.235	44.82	PK2	38.6	-33.3	0	50.12	-	-	74	-23.88	60	203	H
	* 11811.952	33.32	MAv1	38.6	-33.2	2.01	40.73	54	-13.27	-	-	60	203	H
5	* 4804.629	50.37	PK2	34.2	-39.9	0	44.67	-	-	74	-29.33	245	228	V
	* 4803.73	40.05	MAv1	34.2	-39.8	2.01	36.46	54	-17.54	-	-	245	228	V
6	* 11519.348	45.07	PK2	38.3	-33.8	0	49.57	-	-	74	-24.43	302	266	V
	* 11519.699	33.67	MAv1	38.3	-33.8	2.01	40.18	54	-13.82	-	-	302	266	V

* - indicates frequency in CFR47 Pt 15
 PK2 - KDB558074 Method: Maximum Peak
 MAv1 - KDB558074 Option 1 Maximum RMS Average

MID CHANNEL RESULTS

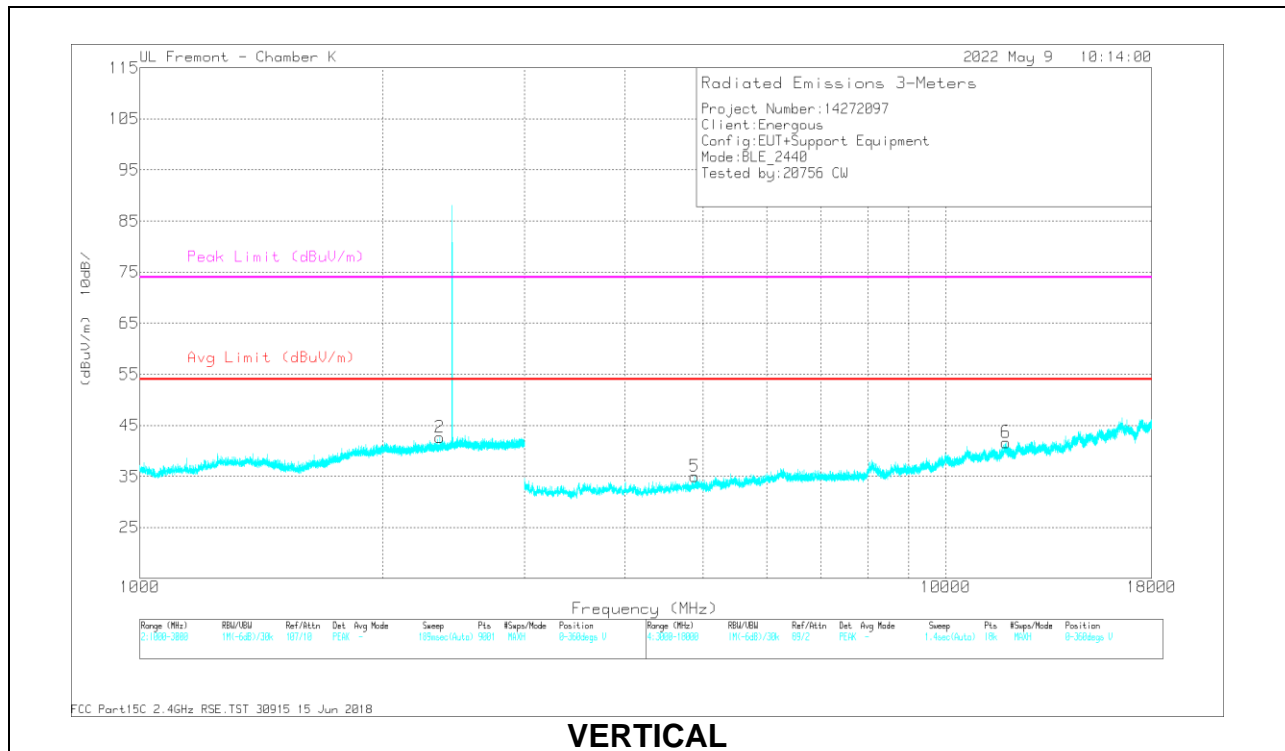
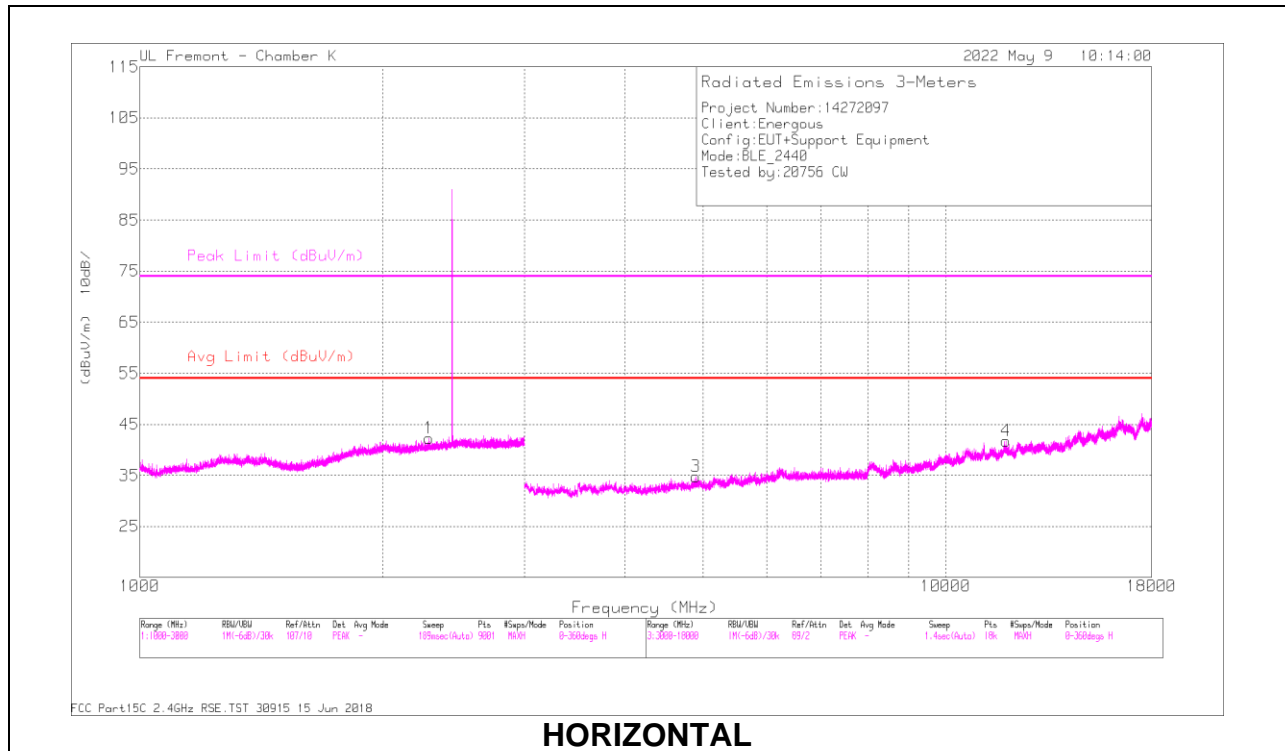

RADIATED EMISSIONS

Marker	Frequency (MHz)	Meter Reading (dBuV)	Det	AF 80404 (dB/m)	Amp/Cbl/Pad (dB)	DC Corr (dB)	Corrected Reading (dBuV/m)	Avg Limit (dBuV/m)	Margin (dB)	Peak Limit (dBuV/m)	PK Margin (dB)	Azimuth (Degs)	Height (cm)	Polarity
1	* 2285.904	54.15	PK2	31.9	-34.9	0	51.15	-	-	74	-22.85	295	216	H
	* 2284.773	42.48	MAv1	31.9	-34.8	2.01	41.59	54	-12.41	-	-	295	216	H
2	* 2358.659	53.6	PK2	32	-34.5	0	51.1	-	-	74	-22.9	359	354	V
	* 2356.038	42.08	MAv1	32	-34.5	2.01	41.59	54	-12.41	-	-	359	354	V
3	* 4898.698	49.23	PK2	34.1	-39.7	0	43.63	-	-	74	-30.37	337	117	H
	* 4898.965	37.84	MAv1	34.1	-39.7	2.01	34.25	54	-19.75	-	-	337	117	H
4	* 11880.29	44.9	PK2	38.7	-33.5	0	50.1	-	-	74	-23.9	175	385	H
	* 11882.096	33.51	MAv1	38.7	-33.4	2.01	40.82	54	-13.18	-	-	175	385	H
5	* 4880.267	50.29	PK2	34.1	-39.8	0	44.59	-	-	74	-29.41	291	126	V
	* 4879.584	39.86	MAv1	34.1	-39.8	2.01	36.17	54	-17.83	-	-	291	126	V
6	* 11869.39	44.77	PK2	38.7	-33.5	0	49.97	-	-	74	-24.03	152	335	V
	* 11869.254	33.36	MAv1	38.7	-33.5	2.01	40.57	54	-13.43	-	-	152	335	V

* - indicates frequency in CFR47 Pt 15
 PK2 - KDB558074 Method: Maximum Peak
 MAv1 - KDB558074 Option 1 Maximum RMS Average

HIGH CHANNEL RESULTS

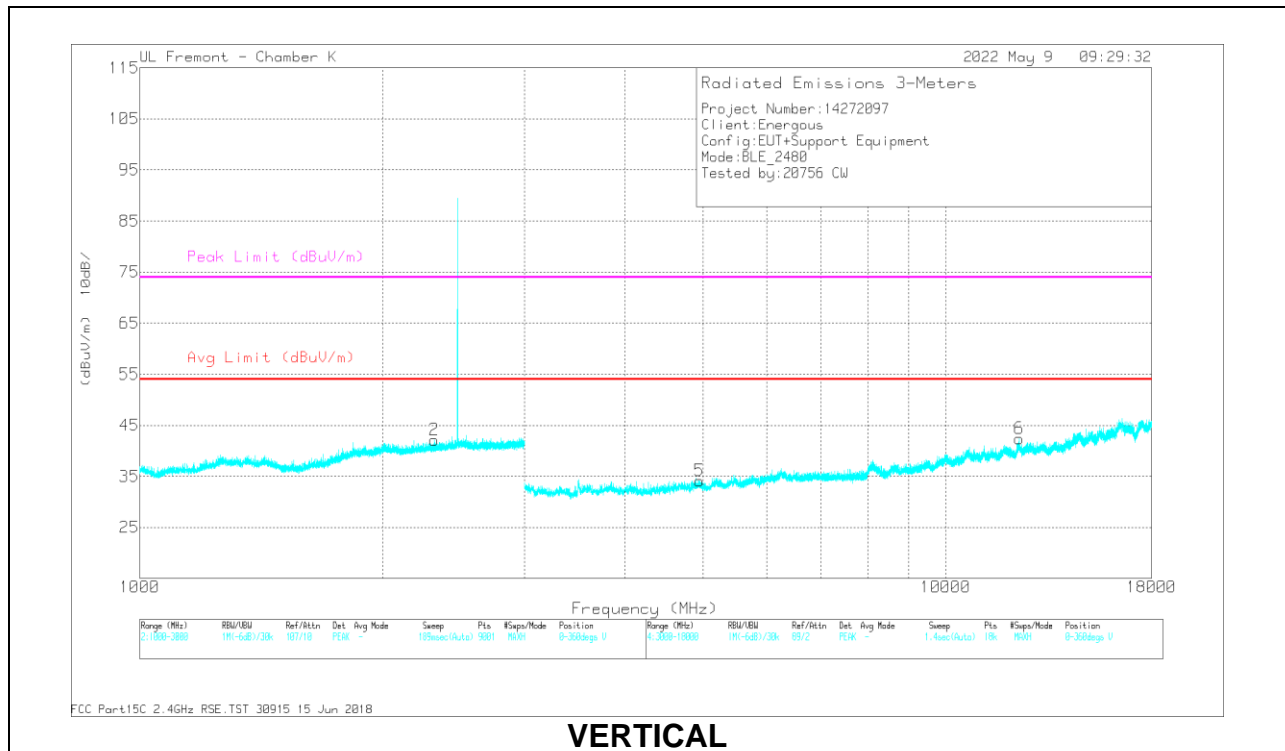
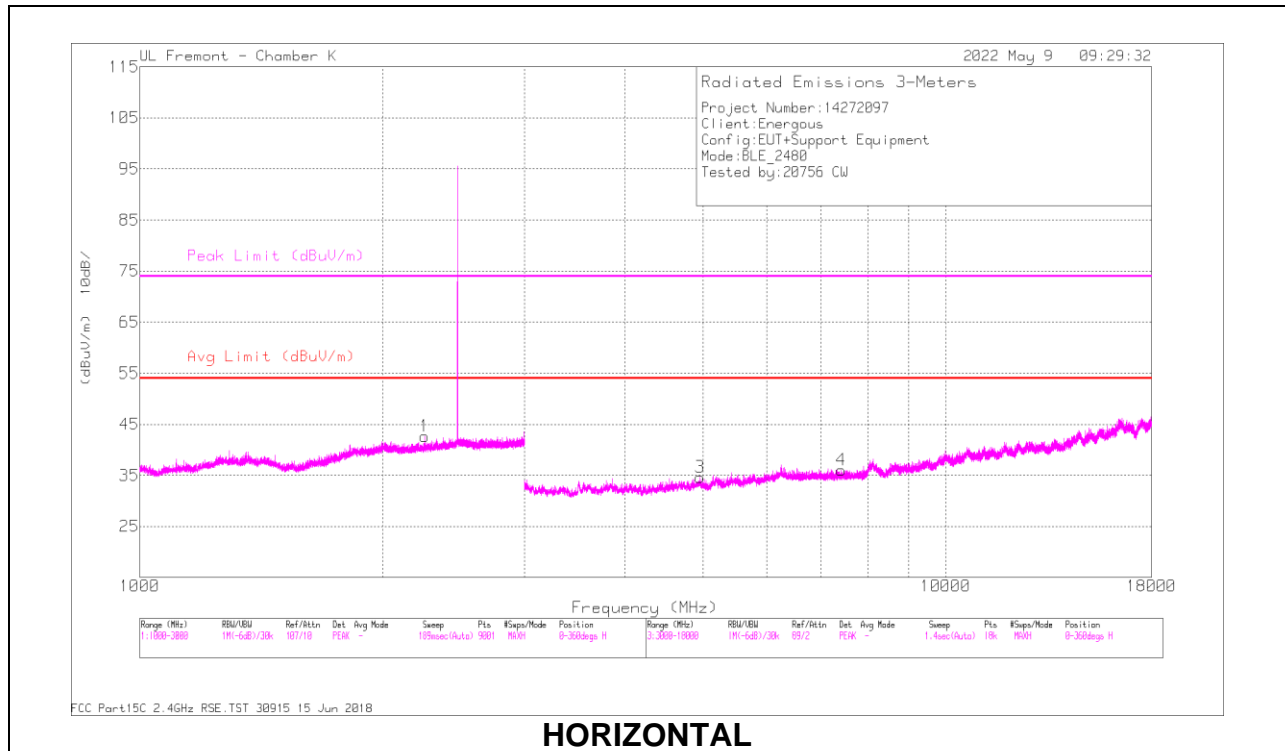

RADIATED EMISSIONS

Marker	Frequency (MHz)	Meter Reading (dBuV)	Det	AF 80404 (dB/m)	Amp/Cbl/Pad (dB)	DC Corr (dB)	Corrected Reading (dBuV/m)	Avg Limit (dBuV/m)	Margin (dB)	Peak Limit (dBuV/m)	PK Margin (dB)	Azimuth (Degs)	Height (cm)	Polarity
1	* 2259.731	54.16	PK2	31.8	-34.9	0	51.06	-	-	74	-22.94	273	352	H
	* 2257.425	42.52	MAv1	31.8	-34.9	2.01	41.43	54	-12.57	-	-	273	352	H
	* 2320.364	54.31	PK2	31.9	-34.7	0	51.51	-	-	74	-22.49	103	379	V
2	* 2320.64	42.36	MAv1	31.9	-34.7	2.01	41.57	54	-12.43	-	-	103	379	V
	* 4960.363	50.56	PK2	34.1	-39.9	0	44.76	-	-	74	-29.24	345	105	H
	* 4959.692	39.85	MAv1	34.1	-39.8	2.01	36.16	54	-17.84	-	-	345	105	H
3	* 7423.419	46.68	PK2	35.8	-37	0	45.48	-	-	74	-28.52	100	150	H
	* 7423.483	34.77	MAv1	35.8	-37	2.01	35.58	54	-18.42	-	-	100	150	H
	* 4950.593	49.23	PK2	34.2	-39.7	0	43.73	-	-	74	-30.27	14	244	V
4	* 4953.103	38.1	MAv1	34.2	-39.8	2.01	34.51	54	-19.49	-	-	14	244	V
	* 12344.022	45.75	PK2	39.1	-32.8	0	52.05	-	-	74	-21.95	284	320	V
	* 12344.045	33.16	MAv1	39.1	-32.8	2.01	41.47	54	-12.53	-	-	284	320	V

* - indicates frequency in CFR47 Pt 15
 PK2 - KDB558074 Method: Maximum Peak
 MAv1 - KDB558074 Option 1 Maximum RMS Average

10.3. WORST CASE BELOW 30MHZ

SPURIOUS EMISSIONS BELOW 30 MHz (WORST-CASE CONFIGURATION)

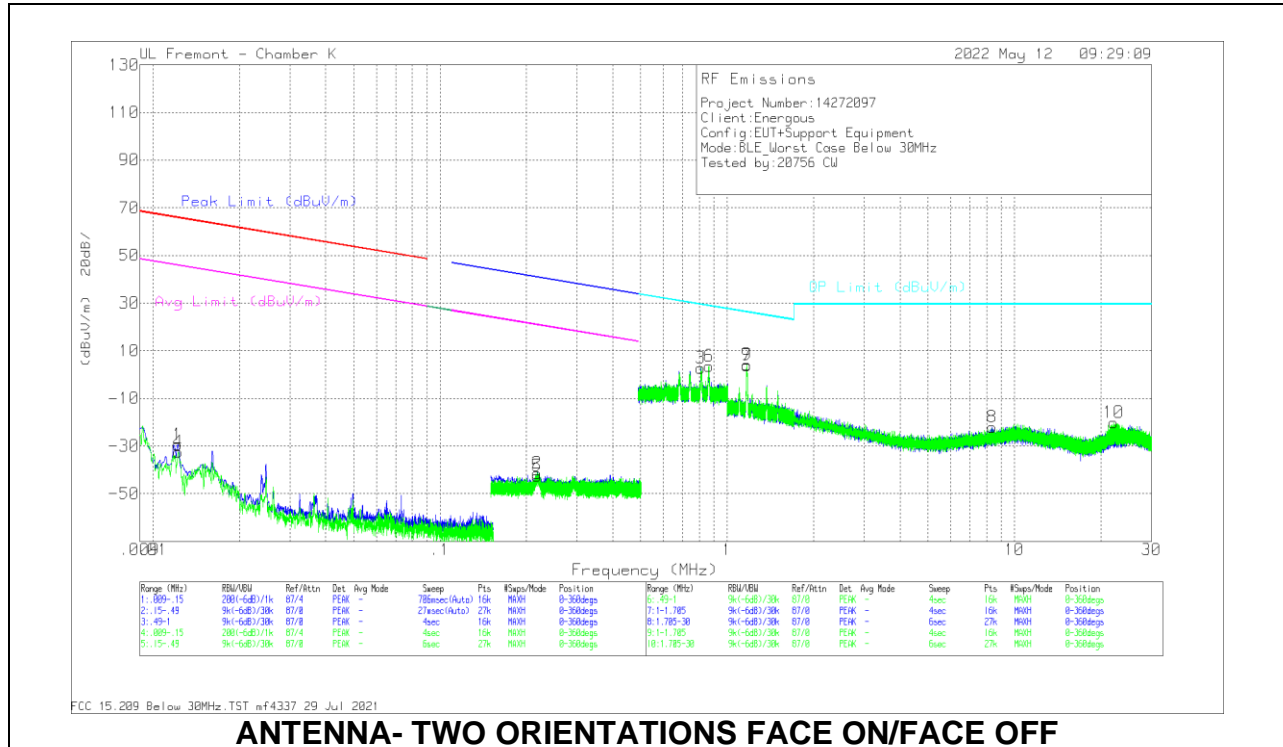

ANTENNA- TWO ORIENTATIONS FACE ON/FACE OFF

Below 30MHz Data

Marker	Frequency (MHz)	Meter Reading (dBuV)	Det	Loop Antenna (E ACF)	Amp/Cbl (dB)	Dist Corr 300m	Corrected Reading (dBuV/m)	Peak Limit (dBuV/m)	PK Margin (dB)	Avg Limit (dBuV/m)	Margin (dB)	Peak Limit (dBuV/m)	PK Margin (dB)	Avg Limit (dBuV/m)	Margin (dB)	Azimuth (Degs)
1	.0122	21.47	Pk	60.1	-31	-80	-29.43	65.85	-95.28	45.85	-75.28	-	-	-	-	0-360
2	.2181	14.62	Pk	56.2	-32.2	-80	-41.38	-	-	-	-	40.84	-82.22	20.84	-62.22	0-360
4	.0123	18.44	Pk	60.1	-31	-80	-32.46	65.8	-98.26	45.8	-78.26	-	-	-	-	0-360
5	.2176	13.53	Pk	56.2	-32.2	-80	-42.47	-	-	-	-	40.86	-83.33	20.86	-63.33	0-360

Pk - Peak detector

Marker	Frequency (MHz)	Meter Reading (dBuV)	Det	Loop Antenna (E ACF)	Amp/Cbl (dB)	Dist Corr 30m (dB) -40Log	Corrected Reading (dBuV/m)	QP Limit (dBuV/m)	Margin (dB)	Azimuth (Degs)
3	.8093	18.58	Pk	56.2	-32.1	-40	2.68	29.45	-26.77	0-360
6	.8625	19.4	Pk	56.2	-32.1	-40	3.5	28.9	-25.4	0-360
7	1.1695	30.03	Pk	45.8	-32.1	-40	3.73	26.27	-22.54	0-360
8	8.3556	15.21	Pk	34.4	-31.8	-40	-22.19	29.5	-51.69	0-360
9	11.694	30.5	Pk	45.8	-32.1	-40	4.2	28.27	-22.07	0-360
10	22.0876	17.81	Pk	33.7	-31.6	-40	-20.09	29.5	-49.59	0-360

Pk - Peak detector

10.4. WORST CASE BELOW 1 GHZ

SPURIOUS EMISSIONS 30 TO 1000 MHz (WORST-CASE CONFIGURATION)

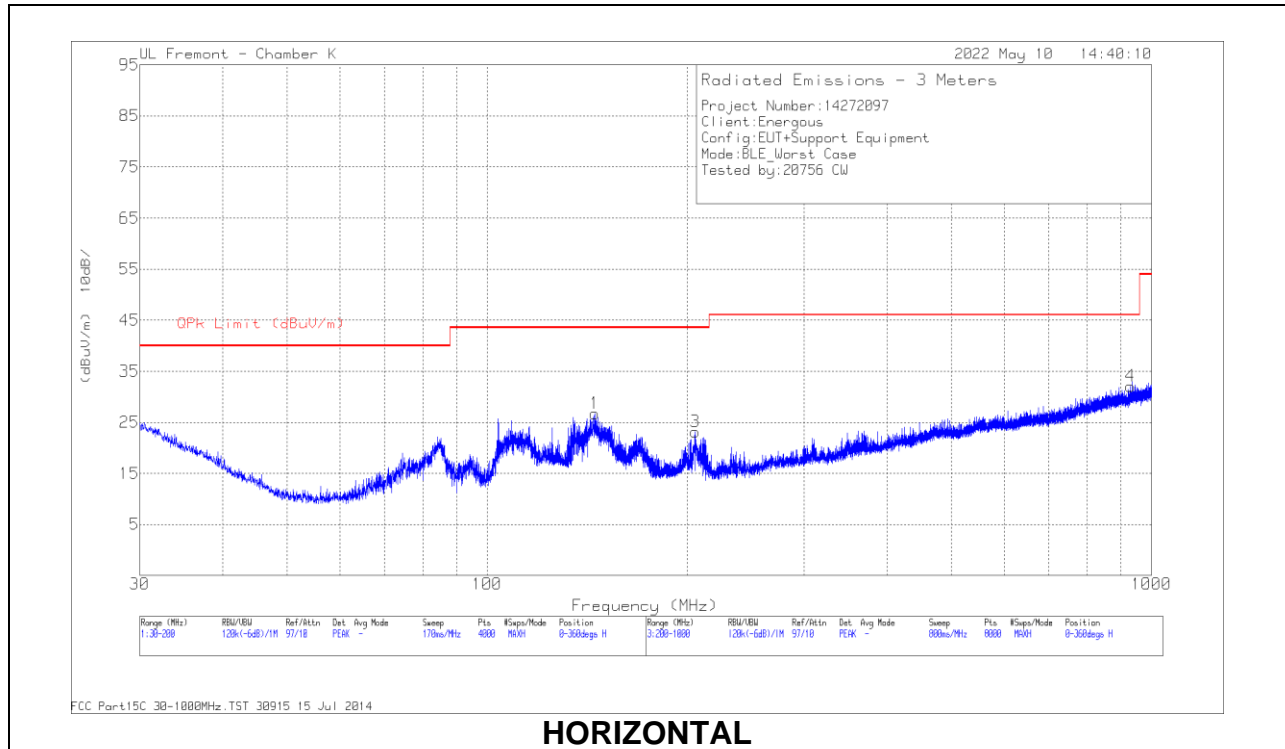

HORIZONTAL

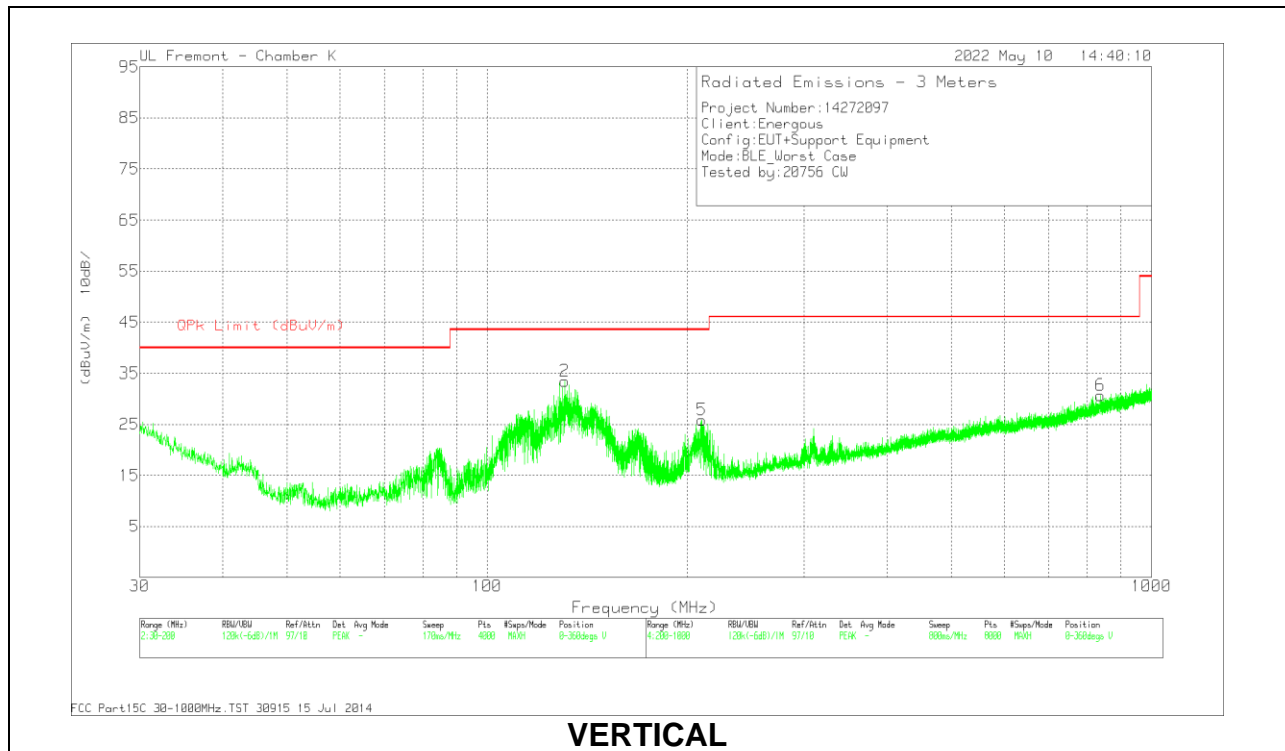

VERTICAL

Below 1GHz Data

Marker	Frequency (MHz)	Meter Reading (dBuV)	Det	82258 ACF (dB)	Amp/Cbl (dB)	Corrected Reading (dBuV/m)	QPk Limit (dBuV/m)	Margin (dB)	Azimuth (Degs)	Height (cm)	Polarity
1	145.29	38.29	Pk	19	-30.6	26.69	43.52	-16.83	0-360	197	H
2	129.962	45.24	Pk	20.2	-30.7	34.74	43.52	-8.78	186	114	V
	129.962	33.59	Qp	20.2	-30.7	23.09	43.52	-20.43	186	114	V
3	205.501	36.01	Pk	17.4	-30.3	23.11	43.52	-20.41	0-360	100	H
4	930.495	29.61	Pk	29.2	-26.8	32.01	46.02	-14.01	0-360	394	H
5	210.301	38.92	Pk	17.1	-30.2	25.82	43.52	-17.7	0-360	101	V
6	836.883	30.08	Pk	28.2	-27.6	30.68	46.02	-15.34	0-360	199	V

Pk - Peak detector

Qp - Quasi-Peak detector

10.5. WORST CASE 18-26 GHZ

SPURIOUS EMISSIONS 18-26 (WORST-CASE CONFIGURATION)

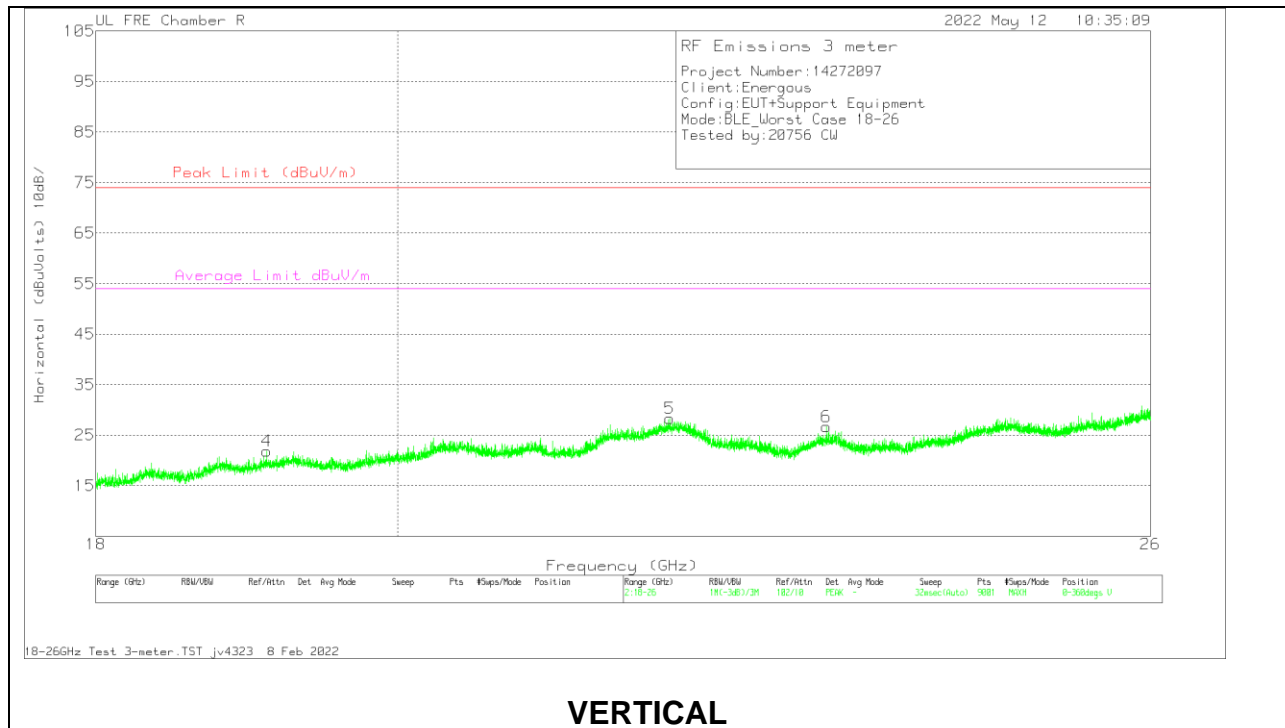
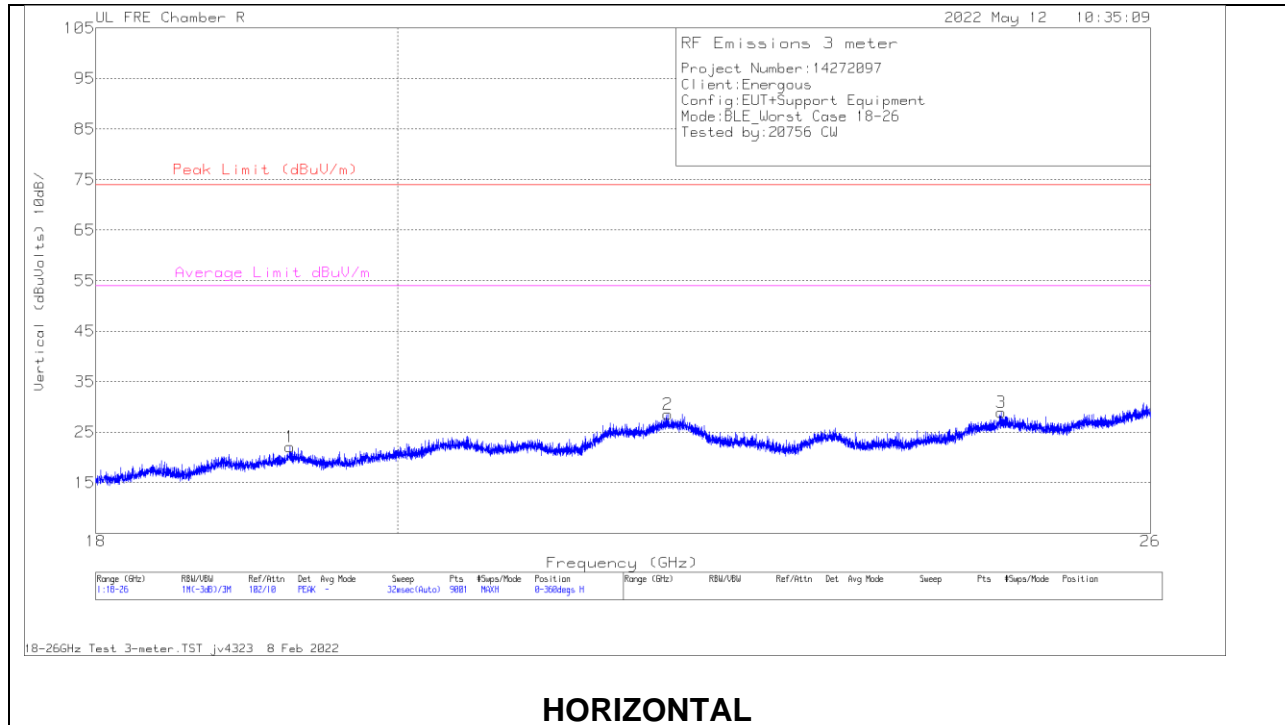

18 – 26GHz DATA

Marker	Frequency (GHz)	Meter Reading (dBuV)	Det	172363 AF (dB/m)	171583 Amp (dB)	Cables (dB)	DC Corr (dB)	Corrected Reading (dBuVolts)	Peak Limit (dBuV/m)	PK Margin (dB)	Average Limit dBuV/m	Margin (dB)	Azimuth (Degs)	Height (cm)	Polarity
1	* 19.260445	40.37	Pk	32.8	-65.5	14.4	0	22.07	74	-51.93	54	-31.93	0-360	99	H
4	* 19.104889	40.26	Pk	32.8	-65.5	14.3	0	21.86	74	-52.14	54	-32.14	0-360	99	V
2	21.975112	44.6	Pk	33.5	-65	15.4	0	28.5	74	-45.5	54	-25.5	0-360	99	H
5	21.989334	44.46	Pk	33.5	-65	15.4	0	28.36	74	-45.64	54	-25.64	0-360	99	V
6	23.221334	42.6	Pk	33.9	-65.6	15.8	0	26.7	74	-47.3	54	-27.3	0-360	99	V
3	24.684445	42.34	Pk	34.5	-64.2	16.3	0	28.94	74	-45.06	54	-25.06	0-360	99	H

* - indicates frequency in CFR47 Pt 15 / IC RSS-Restricted Band
 Pk - Peak detector

11. AC POWER LINE CONDUCTED EMISSIONS

LIMITS

FCC §15.207 (a)

Frequency of Emission (MHz)	Conducted Limit (dB μ V)	
	Quasi-peak	Average
0.15-0.5	66 to 56 *	56 to 46 *
0.5-5	56	46
5-30	60	50

*Decreases with the logarithm of the frequency.

RESULTS

LINE 1 RESULTS

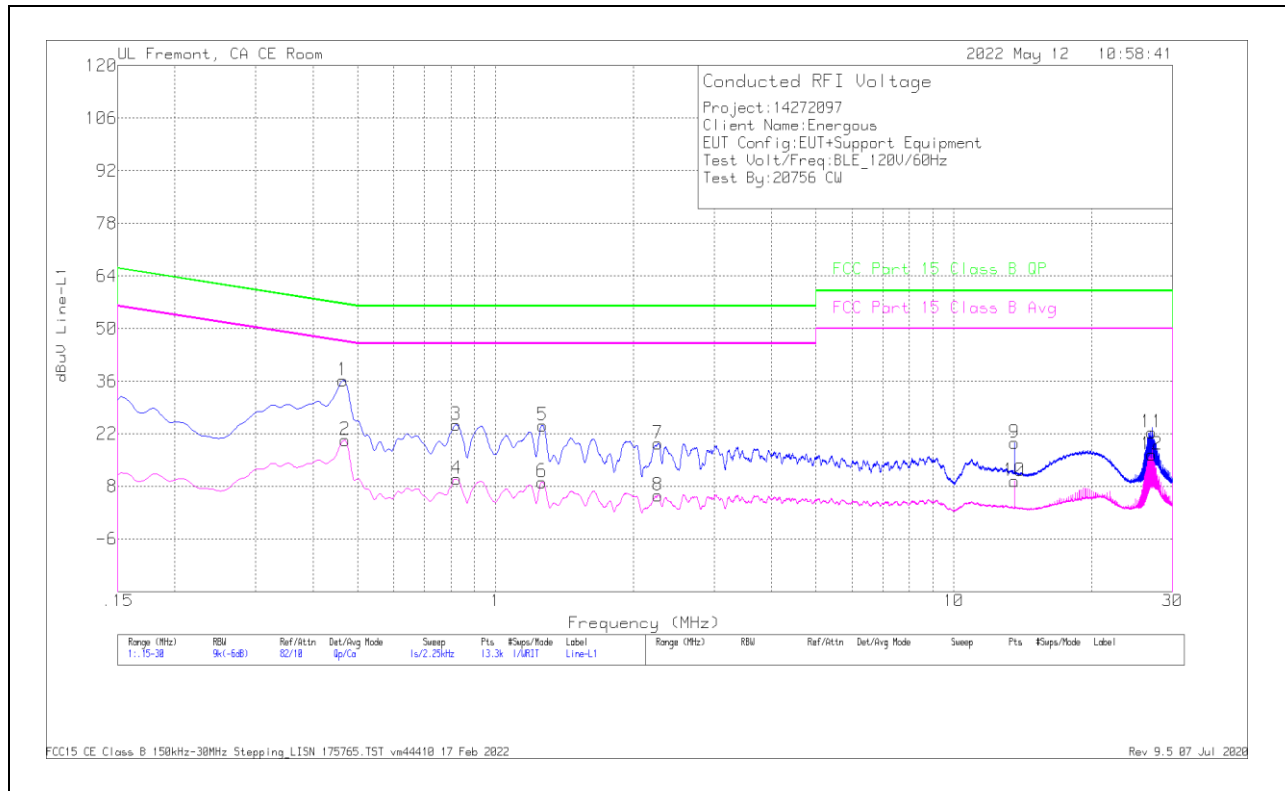

Range 1: Line-L1 .15 - 30MHz											
Marker	Frequency (MHz)	Meter Reading (dBuV)	Det	175765 LISN L1	C1&C3 cable	TekBox Limiter TBFL1 207996	Corrected Reading dBuV	FCC Part 15 Class B QP	QP Margin (dB)	FCC Part 15 Class B Avg	Av(CISPR)Margin (dB)
2	.4695	10.96	Ca	0	0	9.3	20.26	-	-	46.52	-26.26
4	.82275	.53	Ca	0	.1	9.3	9.93	-	-	46	-36.07
6	1.26375	-.22	Ca	0	.1	9.3	9.18	-	-	46	-36.82
8	2.2605	-3.74	Ca	0	.1	9.3	5.66	-	-	46	-40.34
10	13.56	-1.14	Ca	.1	.2	9.3	9.46	-	-	50	-40.54
12	27.0555	6.5	Ca	.2	.3	9.4	16.4	-	-	50	-33.6
1	.465	26.92	Qp	0	0	9.3	36.22	56.6	-20.38	-	-
3	.82163	15.02	Qp	0	.1	9.3	24.42	56	-31.58	-	-
5	1.266	14.86	Qp	0	.1	9.3	24.26	56	-31.74	-	-
7	2.265	10.04	Qp	0	.1	9.3	19.44	56	-36.56	-	-
9	13.56	10	Qp	.1	.2	9.3	19.6	60	-40.4	-	-
11	27.01725	12.52	Qp	.2	.3	9.4	22.42	60	-37.58	-	-

Qp - Quasi-Peak detector

Ca - CISPR average detection

NOTE: Markers 9 and 10, 13.56MHz is an external NFC signal unrelated to the EUT.

LINE 2 RESULTS

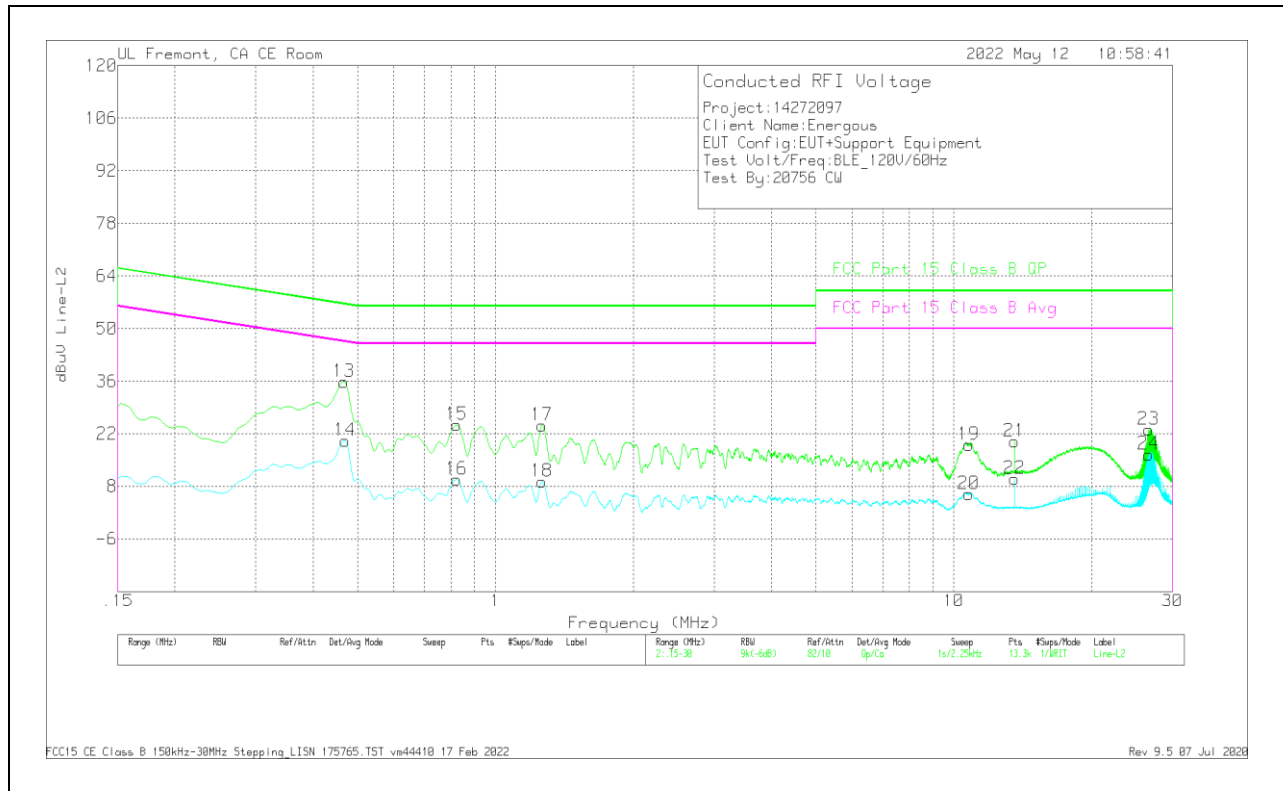

Range 2: Line-L2 .15 - 30MHz											
Marker	Frequency (MHz)	Meter Reading (dBuV)	Det	175765 LISN L2	C2&C3 cable	TekBox Limiter TBFL1 207996	Corrected Reading dBuV	FCC Part 15 Class B QP	QP Margin (dB)	FCC Part 15 Class B Avg	Av(CISPR)Margin (dB)
14	.4695	10.8	Ca	0	0	9.3	20.1	-	-	46.52	-26.42
16	.82275	.44	Ca	0	.1	9.3	9.84	-	-	46	-36.16
18	1.26375	-.18	Ca	0	.1	9.3	9.22	-	-	46	-36.78
20	10.79475	-3.64	Ca	.1	.2	9.3	5.96	-	-	50	-44.04
22	13.56	.35	Ca	.1	.2	9.3	9.95	-	-	50	-40.05
24	26.63925	6.75	Ca	.2	.3	9.3	16.55	-	-	50	-33.45
13	.46725	26.59	Qp	0	0	9.3	35.89	56.56	-20.67	-	-
15	.82275	14.91	Qp	0	.1	9.3	24.31	56	-31.69	-	-
17	1.26375	14.83	Qp	0	.1	9.3	24.23	56	-31.77	-	-
19	10.77675	9.49	Qp	.1	.2	9.3	19.09	60	-40.91	-	-
21	13.56	10.28	Qp	.1	.2	9.3	19.88	60	-40.12	-	-
23	26.63925	13.3	Qp	.2	.3	9.3	23.1	60	-36.9	-	-

Qp - Quasi-Peak detector

Ca - CISPR average detection

NOTE: Markers 21 and 22, 13.56MHz is an external NFC signal unrelated to the EUT.