



# TEST REPORT

**Report Number. :** 13947251-E2V3

**Applicant :** ENERGOUS CORPORATION  
3590 NORTH FIRST STREET,  
SUITE 210,  
SAN JOSE, CA 95134, U.S.A.

**Model :** VN15

**Brand :** ENERGOUS

**FCC ID :** 2ADNG-VN15

**EUT Description :** WIRELESS CHARGER

**Test Standard(s) :** FCC 47 CFR PART 15 SUBPART C

**Date Of Issue:**

October 08, 2021

**Prepared by:**

UL VERIFICATION SERVICES

47173 Benicia Street

Fremont, CA 94538 U.S.A.

TEL: (510) 319-4000

FAX: (510) 661-0888



## REPORT REVISION HISTORY

Rev.	Issue Date	Revisions	Revised By
V1	8/18/2021	Initial Issue	--
V2	8/23/2021	Updated page 42 and 43 with detector definition added	Tina Chu
V3	10/8/2021	Modified EUT description in Section 6.1	Tina Chu

## TABLE OF CONTENTS

<b>REPORT REVISION HISTORY .....</b>	<b>2</b>
<b>TABLE OF CONTENTS .....</b>	<b>3</b>
<b>1. ATTESTATION OF TEST RESULTS.....</b>	<b>5</b>
<b>2. TEST RESULTS SUMMARY .....</b>	<b>7</b>
<b>3. TEST METHODOLOGY .....</b>	<b>7</b>
<b>4. FACILITIES AND ACCREDITATION.....</b>	<b>7</b>
<b>5. DECISION RULES AND MEASUREMENT UNCERTAINTY.....</b>	<b>8</b>
5.1. METROLOGICAL TRACEABILITY .....	8
5.2. DECISION RULES .....	8
5.3. MEASUREMENT UNCERTAINTY .....	8
5.4. SAMPLE CALCULATION.....	8
<b>6. EQUIPMENT UNDER TEST .....</b>	<b>9</b>
6.1. EUT DESCRIPTION.....	9
6.2. MAXIMUM OUTPUT POWER.....	9
6.3. DESCRIPTION OF AVAILABLE ANTENNAS .....	9
6.4. SOFTWARE AND FIRMWARE .....	9
6.5. WORST-CASE CONFIGURATION AND MODE.....	10
6.6. DESCRIPTION OF TEST SETUP.....	11
<b>7. MEASUREMENT METHOD .....</b>	<b>14</b>
<b>8. TEST AND MEASUREMENT EQUIPMENT .....</b>	<b>15</b>
<b>9. ANTENNA PORT TEST RESULTS .....</b>	<b>16</b>
9.1. ON TIME AND DUTY CYCLE .....	16
9.2. 99% BANDWIDTH.....	17
9.3. 6 dB BANDWIDTH .....	18
9.4. OUTPUT POWER .....	19
9.5. AVERAGE POWER.....	20
9.6. POWER SPECTRAL DENSITY .....	21
9.7. CONDUCTED SPURIOUS EMISSIONS.....	22
<b>10. RADIATED TEST RESULTS.....</b>	<b>24</b>

---

10.1.	LIMITS AND PROCEDURE.....	24
10.2.	TRANSMITTER ABOVE 1 GHZ.....	26
10.3.	WORST CASE BELOW 30MHZ.....	36
10.4.	WORST CASE BELOW 1 GHZ.....	37
10.5.	WORST CASE 18-26 GHZ.....	39
<b>11.</b>	<b>AC POWER LINE CONDUCTED EMISSIONS .....</b>	<b>41</b>
<b>12.</b>	<b>SETUP PHOTOS.....</b>	<b>44</b>

## 1. ATTESTATION OF TEST RESULTS

**COMPANY NAME:** ENERGOUS CORPORATION  
3590 NORTH FIRST STREET,  
SUITE 210,  
SAN JOSE, CA 95134, U.S.A.

**EUT DESCRIPTION:** WIRELESS CHARGER

**MODEL:** VN15

**BRAND:** ENERGOUS

**SERIAL NUMBER:** 100D (CONDUCTED); 1012 (RADIATED)

**SAMPLE RECEIPT DATE:** AUGUST 02, 2021

**DATE TESTED:** AUGUST 02, 2021 TO AUGUST 05, 2021

APPLICABLE STANDARDS	
STANDARD	TEST RESULTS
CFR 47 Part 15 Subpart C	Complies

UL Verification Services Inc. tested the above equipment in accordance with the requirements set forth in the above standards. The test results show that the equipment tested is capable of demonstrating compliance with the requirements as documented in this report.

The results documented in this report apply only to the tested sample, under the conditions and modes of operation as described herein. It is the manufacturer's responsibility to assure that additional production units of this model are manufactured with identical electrical and mechanical components. All samples tested were in good operating condition throughout the entire test program. Measurement Uncertainties are published for informational purposes only and were not taken into account unless noted otherwise.

This document may not be altered or revised in any way unless done so by UL Verification Services Inc. and all revisions are duly noted in the revisions section. Any alteration of this document not carried out by UL Verification Services Inc. will constitute fraud and shall nullify the document. This report must not be used by the client to claim product certification, approval, or endorsement by A2LA, NIST, any agency of the Federal Government, or any agency of the U.S. government.

Approved & Released For  
UL Verification Services Inc. By:



---

DAN CORONIA  
OPERATIONS LEAD  
UL Verification Services Inc.

Prepared By:

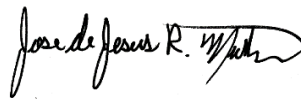

---

JOSE MARTINEZ  
TEST ENGINEER  
UL Verification Services Inc.

Reviewed By:

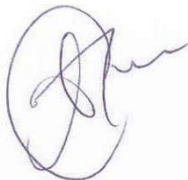

---

TINA CHU  
SENIOR PROJECT ENGINEER  
UL Verification Services Inc.

## 2. TEST RESULTS SUMMARY

This report contains data provided by the customer which can impact the validity of results. UL Verification Services Inc. is only responsible for the validity of results after the integration of the data provided by the customer.

FCC Clause	Requirement	Result	Comment
See Comment	Duty Cycle	Reporting purposes only	ANSI C63.10 Section 11.6.
-	99% OBW	Reporting purposes only	ANSI C63.10 Section 6.9.3.
15.247 (a) (2)	6dB BW	Complies	None.
15.247 (b) (3)	Output Power	Complies	None.
See Comment	Average power	Reporting purposes only	Per ANSI C63.10, Section 11.9.2.3.2.
15.247 (e)	PSD	Complies	None.
15.247 (d)	Conducted Spurious Emissions	Complies	None.
15.209, 15.205	Radiated Emissions	Complies	None.
15.207	AC Mains Conducted Emissions	Complies	None.

## 3. TEST METHODOLOGY

The tests documented in this report were performed in accordance with FCC CFR 47 Part 2, FCC CFR 47 Part 15, ANSI C63.10-2013, KDB 558074 D01 15.247 Meas Guidance v05r02, KDB 414788 D01 Radiated Test Site v01r01.

## 4. FACILITIES AND ACCREDITATION

UL LLC is accredited by A2LA, certification #0751.05, for all testing performed within the scope of this report. Testing was performed at the locations noted below.

	Address	ISED CABID	ISED Company Number	FCC Registration
<input type="checkbox"/>	Building 1: 47173 Benicia Street, Fremont, CA 94538, USA	US0104	2324A	208313
<input type="checkbox"/>	Building 2: 47266 Benicia Street, Fremont, CA 94538, USA	US0104	22541	208313
<input checked="" type="checkbox"/>	Building 4: 47658 Kato Rd, Fremont, CA 94538, USA	US0104	2324B	208313

## 5. DECISION RULES AND MEASUREMENT UNCERTAINTY

### 5.1. METROLOGICAL TRACEABILITY

All test and measuring equipment utilized to perform the tests documented in this report are calibrated on a regular basis, with a maximum time between calibrations of one year or the manufacturers' recommendation, whichever is less, and where applicable is traceable to recognized national standards.

### 5.2. DECISION RULES

The Decision Rule is based on Simple Acceptance in accordance with ISO Guide 98-4:2012 Clause 8.2. (Measurement uncertainty is not taken into account when stating conformity with a specified requirement.)

### 5.3. MEASUREMENT UNCERTAINTY

Where relevant, the following measurement uncertainty levels have been estimated for tests performed on the apparatus:

PARAMETER	U <sub>Lab</sub>
Worst Case Conducted Disturbance, 9KHz to 0.15 MHz	3.78 dB
Worst Case Conducted Disturbance, 0.15 to 30 MHz	3.40 dB
Worst Case Radiated Disturbance, 9KHz to 30 MHz	2.84 dB
Worst Case Radiated Disturbance, 30 to 1000 MHz	6.01 dB
Worst Case Radiated Disturbance, 1000 to 18000 MHz	4.73 dB
Worst Case Radiated Disturbance, 18000 to 26000 MHz	4.51 dB
Worst Case Radiated Disturbance, 26000 to 40000 MHz	5.29 dB

Uncertainty figures are valid to a confidence level of 95%.

### 5.4. SAMPLE CALCULATION

#### **RADIATED EMISSIONS**

Where relevant, the following sample calculation is provided:

$$\text{Field Strength (dBuV/m)} = \text{Measured Voltage (dBuV)} + \text{Antenna Factor (dB/m)} + \text{Cable Loss (dB)} - \text{Preamp Gain (dB)}$$

$$36.5 \text{ dBuV} + 18.7 \text{ dB/m} + 0.6 \text{ dB} - 26.9 \text{ dB} = 28.9 \text{ dBuV/m}$$

#### **MAINS CONDUCTED EMISSIONS**

Where relevant, the following sample calculation is provided:

$$\text{Final Voltage (dBuV)} = \text{Measured Voltage (dBuV)} + \text{Cable Loss (dB)} + \text{Limiter Factor (dB)} + \text{LISN Insertion Loss.}$$

$$36.5 \text{ dBuV} + 0 \text{ dB} + 10.1 \text{ dB} + 0 \text{ dB} = 46.6 \text{ dBuV}$$



## 6. EQUIPMENT UNDER TEST

### 6.1. EUT DESCRIPTION

The EUT is a stand-alone wireless charger with BLE that is mounted on a ceiling or wall. The wireless charger transmits power via a frequency hopping signal between 916.5MHz to 918.1MHz and charges multiple receivers at a time.

This report documents test results of the Bluetooth Low Energy radio portion of the wireless charger.

### 6.2. MAXIMUM OUTPUT POWER

The transmitter has a maximum peak conducted output power as follows:

Frequency Range (MHz)	Mode	Output Power (dBm)	Output Power (mW)
2402 - 2480	BLE	-3.54	0.44

### 6.3. DESCRIPTION OF AVAILABLE ANTENNAS

The antenna(s) gain and type, as provided by the manufacturer' are as follows:

The radio utilizes an integrated antenna, with a maximum gain of 2dBi.

### 6.4. SOFTWARE AND FIRMWARE

The EUT firmware installed during testing was 5.0.255.255\_2054

The test utility software used during testing was 683\_fem\_sky66112\_bypass\_ant1

---

## 6.5. WORST-CASE CONFIGURATION AND MODE

Radiated band edge, harmonics, and spurious emissions from 1 GHz to 18GHz were performed with the EUT was set to transmit at the Low/Middle/High channels.

Radiated emission below 30MHz, below 1GHz, above 18GHz, and power line conducted emission were performed with the EUT was set to transmit at the channel with highest output power as worst-case scenario.

The EUT is a wall or ceiling mounted device and it has one USB type C port for power only. The fundamental of the EUT was investigated in three orthogonal orientations X,Y,Z, it was determined that Y orientation was worst-case orientation; therefore, all final radiated testing was performed with the EUT in Y orientation. Due to applicant is only able to exercise the commands via a USB cable that connected to a laptop, therefore all final radiated and AC line emission testing were performed with the EUT in Y orientation powered by laptop via USB cable.

Worst-case data rate as provided by the client was:  
BLE: 1 Mbps.

BLE and WPT bands operate simultaneously, simultaneous operation results are documented in UL document 13947251-E1 WPT report.

## 6.6. DESCRIPTION OF TEST SETUP

SUPPORT TEST EQUIPMENT						
Description	Manufacturer	Model	Serial Number	FCC ID/ DoC		
Laptop	Dell	Latitude E7470	3F94RC2	DoC		
Laptop AC/DC adapter	Dell	LA65NM130	CN-03NKWD-72438-38D-0F54-A00	DoC		
Faraday Cage	ETS-LINDGREN	Not available (Custom built)	ECSB-001	DoC		
I/O CABLES (RF CONDUCTED TEST)						
Cable No.	Port	# of Identical Ports	Connector Type	Cable Type	Cable Length (m)	Remarks
1	AC	1	AC	Un-shielded	1	AC Mains to AC/DC Adapter
2	DC	1	DC	Un-shielded	1.5	AC/DC Adapter to Laptop
3	USB	1	UART	Un-shielded	1.5	EUT to Laptop
4	Antenna	1	SMA	Un-shielded	0.1	To spectrum analyzer
I/O CABLES (RF RADIATED TEST/AC LINE CONDUCTED TEST)						
Cable No.	Port	# of Identical Ports	Connector Type	Cable Type	Cable Length (m)	Remarks
1	AC	1	AC	Un-shielded	1	
2	DC	1	DC	Un-shielded	1.5	AC/DC Adapter to Laptop
3	USB	1	USB Type C	Un-shielded	1	

**TEST SETUP**

The EUT was connected to the test laptop via USB cable. Test software exercised the EUT.

**SETUP DIAGRAMS**

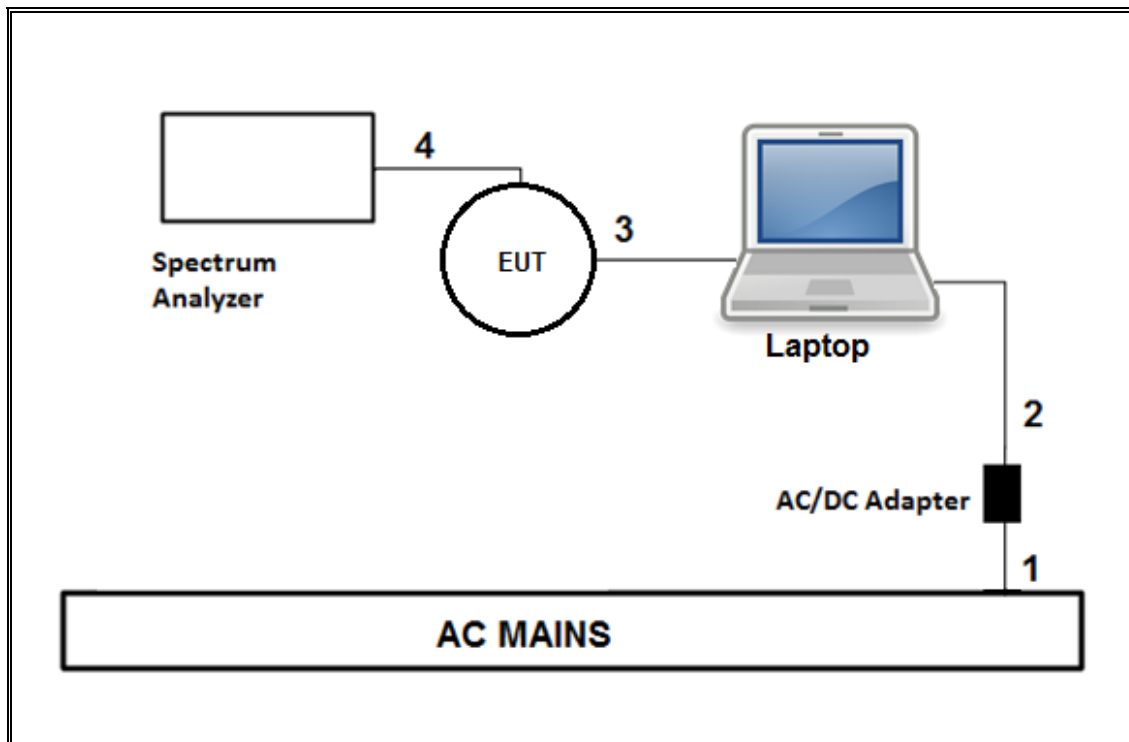

**TEST SETUP- RADIATED TEST / AC LINE CONDUCTED TEST**

The EUT was powered by laptop via USB cable. For radiated test, laptop was put inside a Faraday cage. Test software exercised the EUT.

**SETUP DIAGRAM**

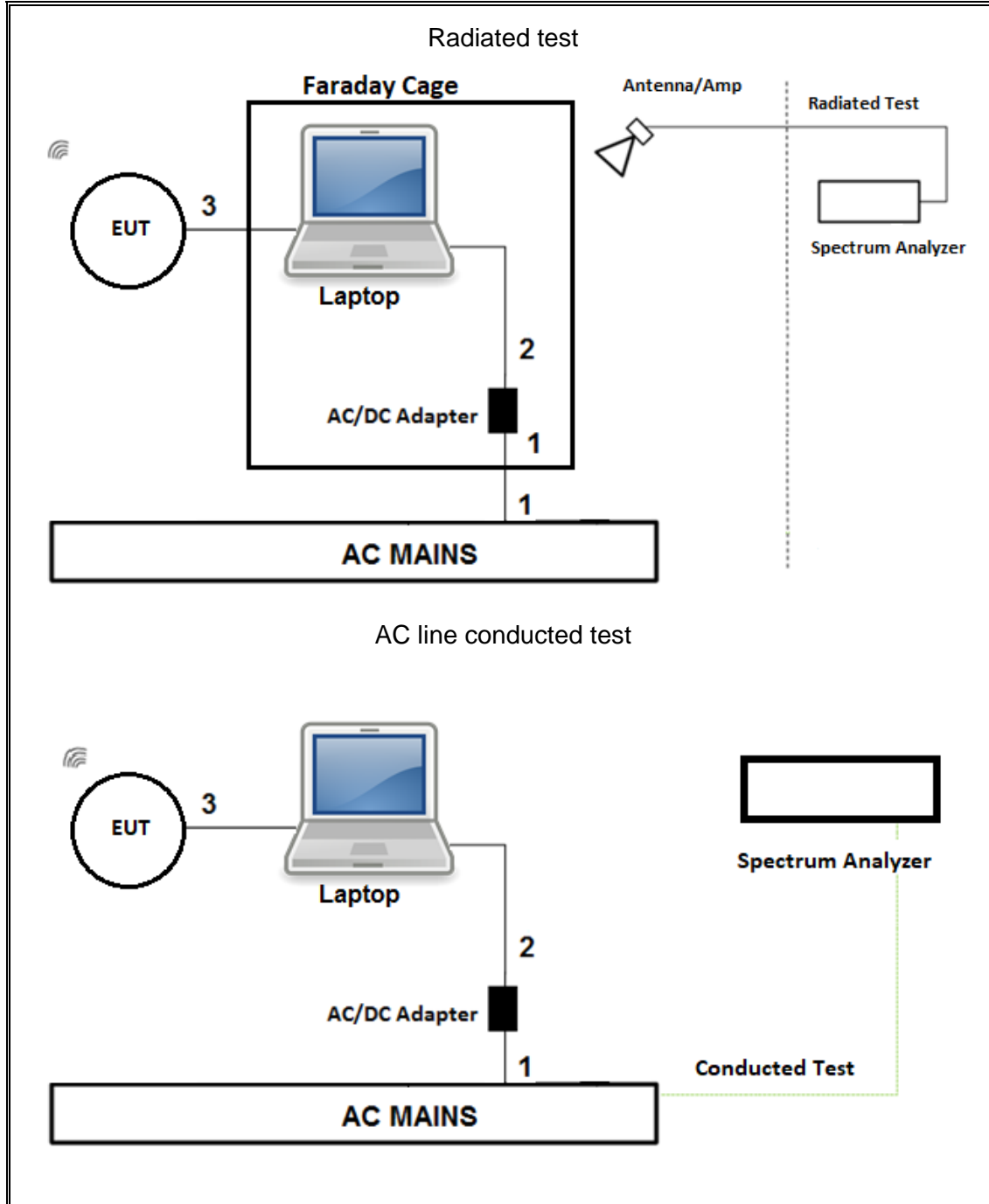

---

## 7. MEASUREMENT METHOD

6 dB BW: ANSI C63.10 Subclause -11.8.1 RBW  $\geq$  DTS BW

Occupied BW (99%): ANSI C63.10-2013 Section 6.9.3

Output Power: ANSI C63.10 Subclause -11.9.1.3 Method PKPM1 Peak-reading power meter

Output Power: ANSI C63.10 Subclause -11.9.2.3.2 Method AVGPM-G (Measurement using a gated RF average-reading power meter)

PSD: ANSI C63.10 Subclause -11.10.2 Method PKPSD (peak PSD)

Radiated emissions non-restricted frequency bands: ANSI C63.10 Subclause -11.11

Radiated emissions restricted frequency bands: ANSI C63.10 Subclause -11.12.1

Conducted emissions in restricted frequency bands: ANSI C63.10 Subclause -11.12.2

Band-edge: ANSI C63.10 Subclause -11.13.3.4 Integration method -Trace averaging across ON and OFF times DC correction

AC Power Line Conducted Emissions: ANSI C63.10-2013, Section 6.2.

Radiated Spurious Emissions Below 30MHz: ANSI C63.10-2013 Section 6.4

## 8. TEST AND MEASUREMENT EQUIPMENT

The following test and measurement equipment was utilized for the tests documented in this report:

TEST EQUIPMENT LIST					
Description	Manufacturer	Model	ID Num	Cal Due	Last Cal
Antenna, Passive Loop 30Hz - 1MHz	ELECTRO METRICS	EM-6871	SC-8015	05/24/2022	05/24/2021
Antenna, Passive Loop 100KHz - 30MHz	ELECTRO METRICS	EM-6872	SC-8014	05/24/2022	05/24/2021
Antenna, Horn 1-18GHz	ETS-Lindgren	3117	T863	08/31/2021	08/31/2020
Amplifier, 100MHz-18GHz	AMPLICAL	AMP0.1G18-47-20	PRE0197319	04/08/2022	04/08/2021
Antenna, Broadband Hybrid, 30MHz to 2GHz	Sunol Sciences Corp.	JB3	81560	09/24/2021	09/24/2020
Amplifier, 9KHz to 1GHz, 32dB	SONOMA INSTRUMENT	310	175953	01/21/2022	01/21/2021
EMI TEST RECEIVER	Rohde & Schwarz	ESW44	PRE0179367	02/21/2022	02/21/2021
Antenna, Horn 18 to 26.5GHz	ARA	MWH-1826/B	T447	09/24/2021	09/24/2020
Rf Amplifier, 18-26.5GHz, 60dB gain	AMPLICAL	AMP18G26.5-60	171590	05/21/2022	05/21/2021
Spectrum Analyzer, PSA, 3Hz to 26.5GHz	Keysight Technologies Inc	E4440A	T198	05/13/2022	05/13/2021
Power Meter, P-series single channel	Keysight Technologies Inc	N1911A	T1272	01/21/2022	01/21/2021
Power Sensor, P - series, 50MHz to 18GHz, Wideband	Keysight Technologies Inc	N1921A	T1223	06/17/2022	06/17/2021
AC Line Conducted					
LISN	Fischer Custom Communications, Inc	FCC-LISN-50/250- 25-2-01-480V	PRE0186446	01/20/2022	01/20/2021
EMI TEST RECEIVER	Rohde & Schwarz	ESR	T1436	02/19/2022	02/19/2021
Transient Limiter	COM-POWER	LIT-930A	PRE0213145	01/20/2022	01/20/2021
UL TEST SOFTWARE LIST					
Radiated Software	UL	UL EMC	Rev 9.5, Jan 03, 2020		
Antenna Port Software	UL	UL RF	Ver 2021.05.12		
AC Line Conducted Software	UL	UL EMC	Rev 9.5, 07 Jul 2020		

## 9. ANTENNA PORT TEST RESULTS

### 9.1. ON TIME AND DUTY CYCLE

#### LIMITS

None; for reporting purposes only.

#### PROCEDURE

ANSI C63.10 Section 11.6 Zero-Span Spectrum Analyzer Method.

#### ON TIME AND DUTY CYCLE RESULTS

Mode	ON Time B (msec)	Period (msec)	Duty Cycle x (linear)	Duty Cycle (%)	Duty Cycle Correction Factor (dB)	1/B Minimum VBW (kHz)
<b>2.4GHz Band</b>						
BLE	0.393	0.627	0.626	62.60	2.03	2.546

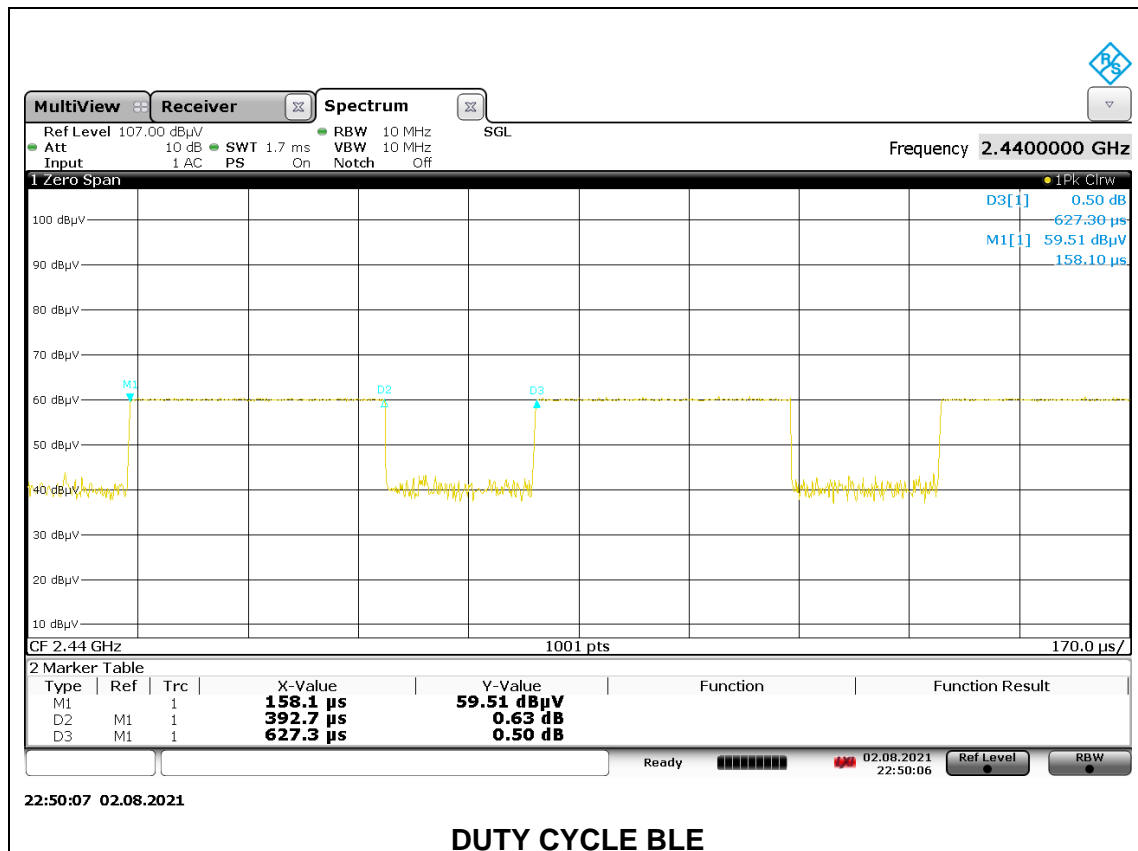



## 9.2. 99% BANDWIDTH

### LIMITS

None; for reporting purposes only.

### RESULTS

Channel	Frequency (MHz)	99% Bandwidth (MHz)
Low	2402	1.043
Middle	2440	1.044
High	2480	1.037

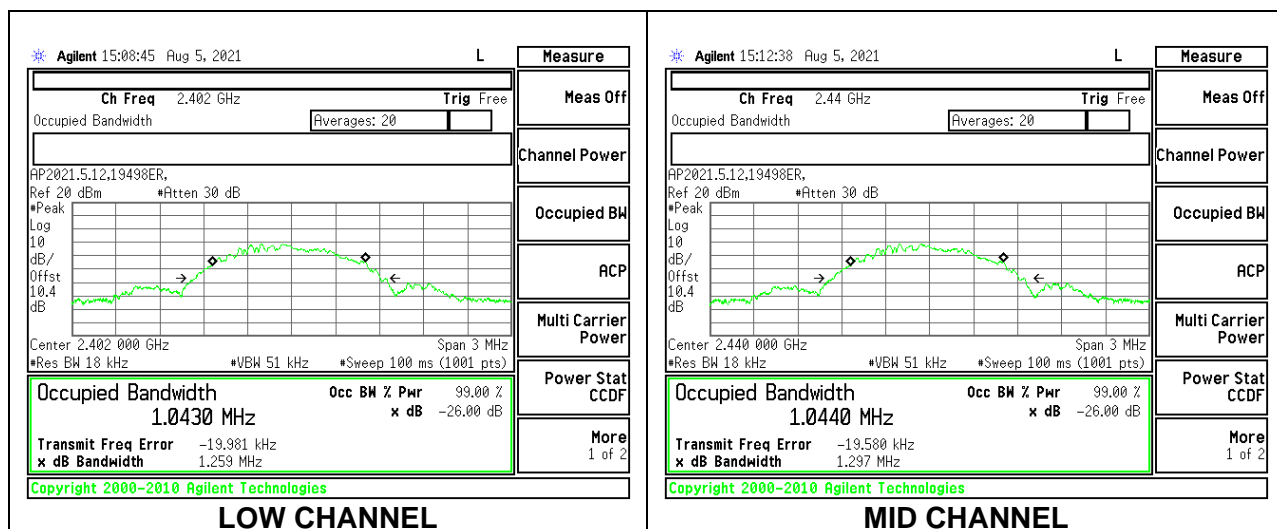

**LOW CHANNEL**

**MID CHANNEL**

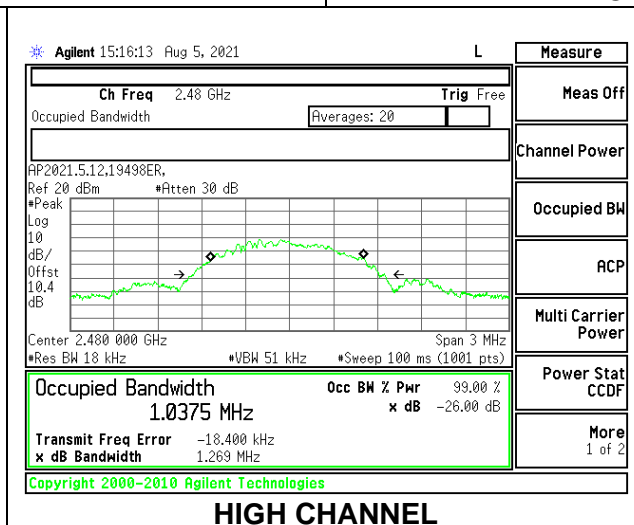

**HIGH CHANNEL**

### 9.3. 6 dB BANDWIDTH

#### LIMITS

FCC §15.247 (a) (2)

The minimum 6 dB bandwidth shall be at least 500 kHz.

#### RESULTS

Channel	Frequency (MHz)	6 dB Bandwidth (MHz)	Minimum Limit (MHz)
Low	2402	0.657	0.5
Middle	2440	0.630	0.5
High	2480	0.666	0.5

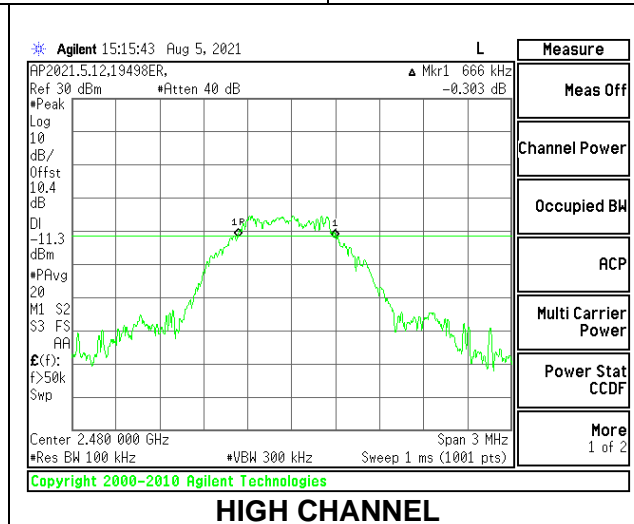
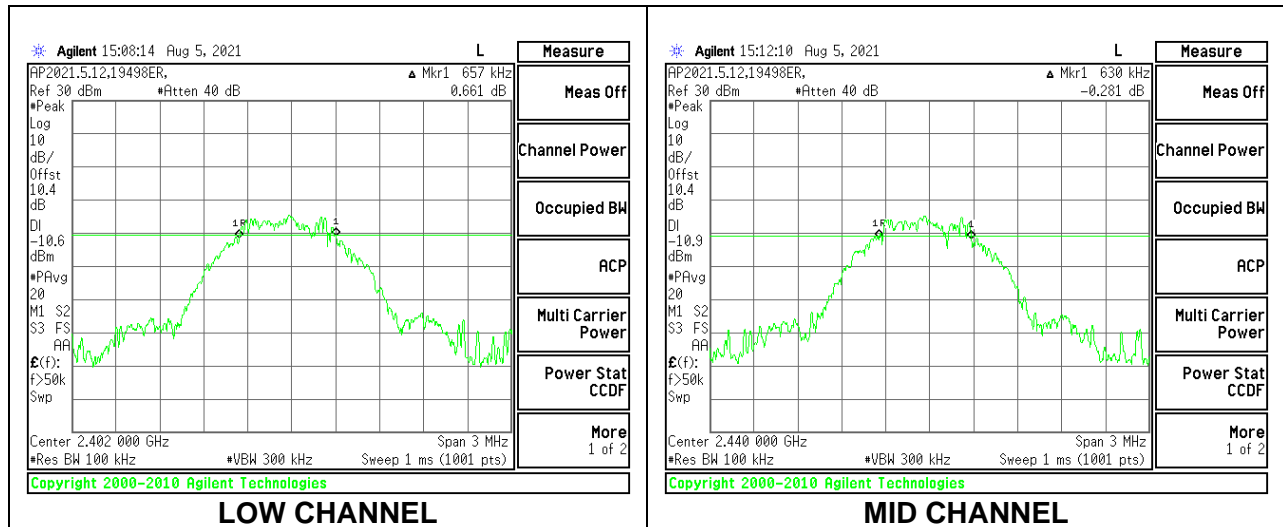

## 9.4. OUTPUT POWER

### LIMITS

FCC §15.247 (b) (3)

The maximum antenna gain is less than or equal to 6 dBi, therefore the limit is 30 dBm.

### TEST PROCEDURE

The transmitter output is connected to a power meter.

The power output was measured on the EUT antenna port using SMA cable with 10dB attenuator connected to a power meter via wideband peak power sensor. Peak output power was read directly from power meter.

### RESULTS

<b>Tested By:</b>	19498 ER
<b>Date:</b>	8/5/2021

<b>Channel</b>	<b>Frequency (MHz)</b>	<b>Peak Power Reading (dBm)</b>	<b>Limit (dBm)</b>	<b>Margin (dB)</b>
Low	2402	-3.54	30	-33.540
Middle	2440	-3.67	30	-33.670
High	2480	-3.85	30	-33.850

## 9.5. AVERAGE POWER

### LIMITS

None; for reporting purposes only.

### TEST PROCEDURE

The transmitter output is connected to a power meter.

The power output was measured on the EUT antenna port using SMA cable with 10dB attenuator connected to a power meter via wideband average power sensor. Gated average output power was read directly from power meter.

### RESULTS

<b>Tested By:</b>	19498 ER
<b>Date:</b>	8/5/2021

<b>Channel</b>	<b>Frequency (MHz)</b>	<b>AV power (dBm)</b>
Low	2402	-4.31
Middle	2440	-4.44
High	2480	-4.59

## 9.6. POWER SPECTRAL DENSITY

### LIMITS

FCC §15.247 (e)

The power spectral density conducted from the transmitter to the antenna shall not be greater than 8 dBm in any 3 kHz band during any time interval of continuous transmission.

### RESULTS

Channel	Frequency (MHz)	PSD (dBm/3kHz)	Limit (dBm/3kHz)	Margin (dB)
Low	2402	-19.283	8	-27.28
Middle	2440	-19.396	8	-27.40
High	2480	-19.309	8	-27.31

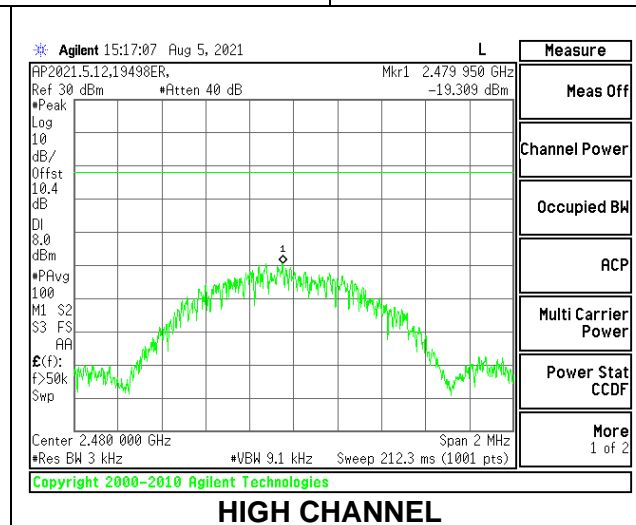
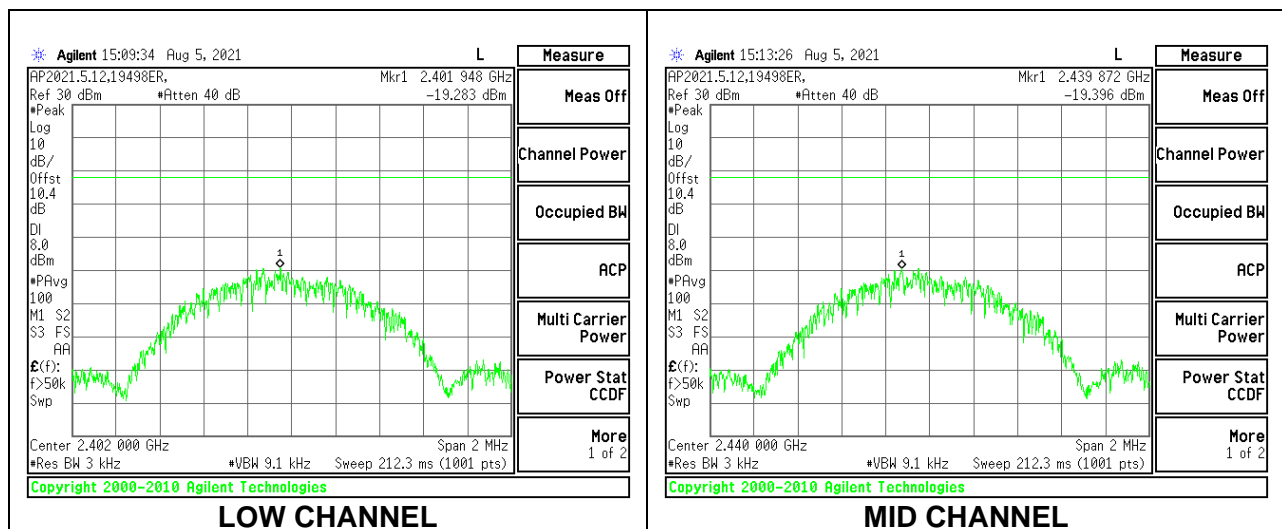

---

## 9.7. CONDUCTED SPURIOUS EMISSIONS

### LIMITS

FCC §15.247 (d)

Output power was measured based on the use of a peak measurement, therefore the required attenuation is 20 dBc.

### RESULTS

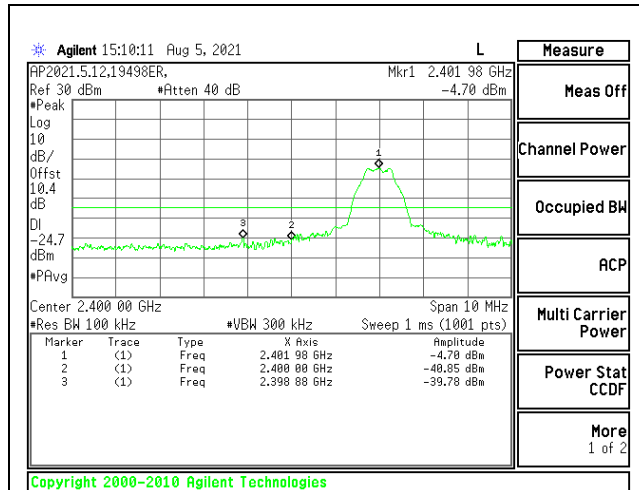

**LOW CHANNEL BANDEDGE**

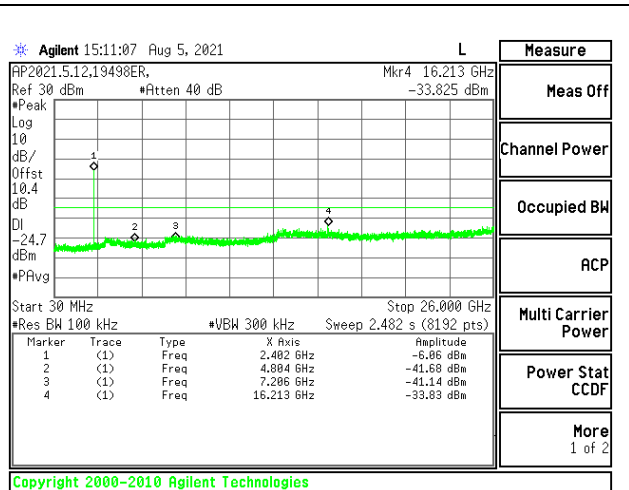

**OUT-OF-BAND LOW CHANNEL**

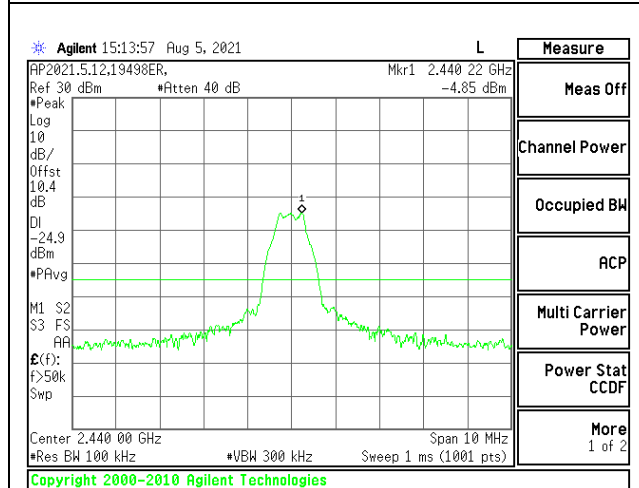

**IN-BAND REFERENCE LEVEL**

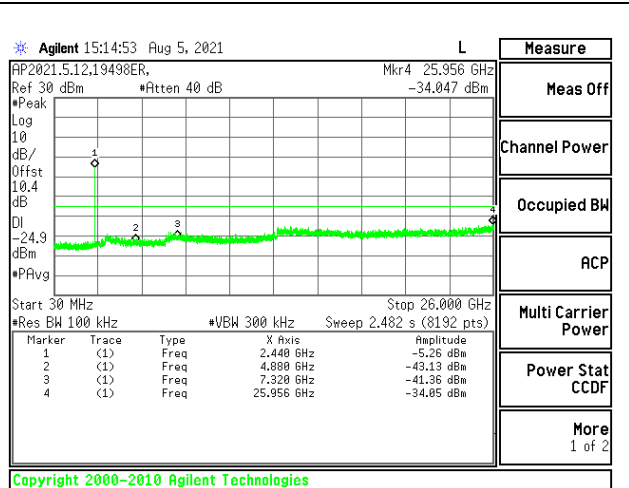

**OUT-OF-BAND MID CHANNEL**

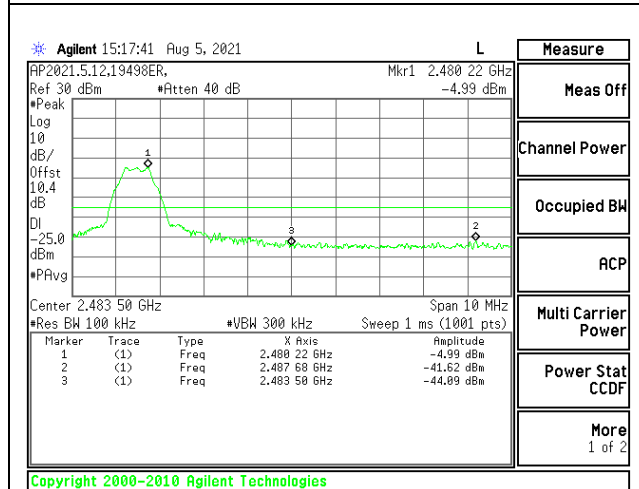

**HIGH CHANNEL BANDEDGE**

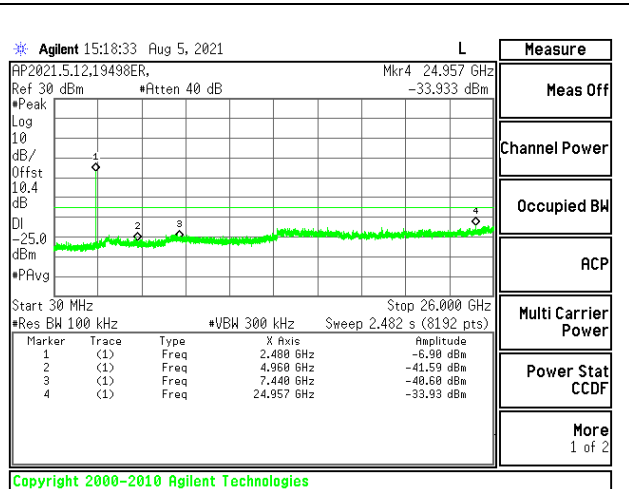

**OUT-OF-BAND HIGH CHANNEL**

## 10. RADIATED TEST RESULTS

### 10.1. LIMITS AND PROCEDURE

#### LIMITS

FCC §15.205 and §15.209

Frequency Range (MHz)	Field Strength Limit (uV/m) at 3 m	Field Strength Limit (dBuV/m) at 3 m
0.009-0.490	2400/F(kHz) @ 300 m	-
0.490-1.705	24000/F(kHz) @ 30 m	-
1.705 - 30	30 @ 30m	-
30 - 88	100	40
88 - 216	150	43.5
216 - 960	200	46
Above 960	500	54

#### TEST PROCEDURE

The EUT is placed on a non-conducting table 80 cm above the ground plane for measurement below 1GHz; 1.5 m above the ground plane for measurement above 1GHz. The antenna to EUT distance is 3 meters. The EUT is configured in accordance with ANSI C63.10. The EUT is set to transmit in a continuous mode.

For measurements below 1 GHz the resolution bandwidth is set to 100 kHz for peak detection measurements or 120 kHz for quasi-peak detection measurements in the 30-1000MHz range, 9kHz for peak and/or quasi-peak detection measurements in the 0.15-30MHz range and 200Hz for peak and/or quasi-peak detection measurements in the 9 to 150kHz range. Peak detection is used unless otherwise noted as quasi-peak or average (9-90kHz and 110-490kHz).

For pre-scans above 1 GHz the resolution bandwidth is set to 1 MHz; the video bandwidth is set to 30 KHz for peak measurements.

For final measurements above 1 GHz the resolution bandwidth is set to 1 MHz; the video bandwidth is set to 3 MHz for peak measurements and as applicable for average measurements.

The spectrum from 1 GHz to 18 GHz is investigated with the transmitter set to the lowest, middle, and highest channels in each applicable band. Below 1GHz and above 18GHz emissions, the channel with the highest output power was tested.

The frequency range of interest is monitored at a fixed antenna height and EUT azimuth. The EUT is rotated through 360 degrees to maximize emissions received. The antenna is scanned from 1 to 4 meters above the ground plane to further maximize the emission. Measurements are made with the antenna polarized in both the vertical and the horizontal positions.



For below 30MHz testing, investigation was done on three antenna orientations (parallel, perpendicular, and ground-parallel), parallel and perpendicular are the worst orientations, therefore testing was performed on these two orientations only. Blue color trace on plots: Parallel orientation. Green color trace on plots: Perpendicular orientation.

Base on FCC 15.31 (f) (2): measurements may be performed at a distance closer than that specified in the regulations; however, an attempt should be made to avoid making measurements in the near field.

**KDB 414788 Open Field Site(OFS) and Chamber Correlation Justification**

OFS and chamber correlation testing had been performed and chamber measured test result is the worst case test result.

NOTE: The limits in CFR 47, Part 15, Subpart C, paragraph 15.209(a), are identical to those in RSS-Gen section 8.9, Table 6, since the measurements are performed in terms of magnetic field strength and converted to electric field strength levels (as reported in the table), using the free space impedance of 377 Ohms. For example the measurement at frequency X kHz resulted in a level of Y dBuV/m, which is equivalent to  $Y - 51.5 = Z$  dBuA/m, which has the same margin, W dB, to the corresponding RSS-Gen Table 6 limit as it has to 15.209(a) limit.

## 10.2. TRANSMITTER ABOVE 1 GHz

### BANDEDGE (LOW CHANNEL)

### HORIZONTAL RESULT

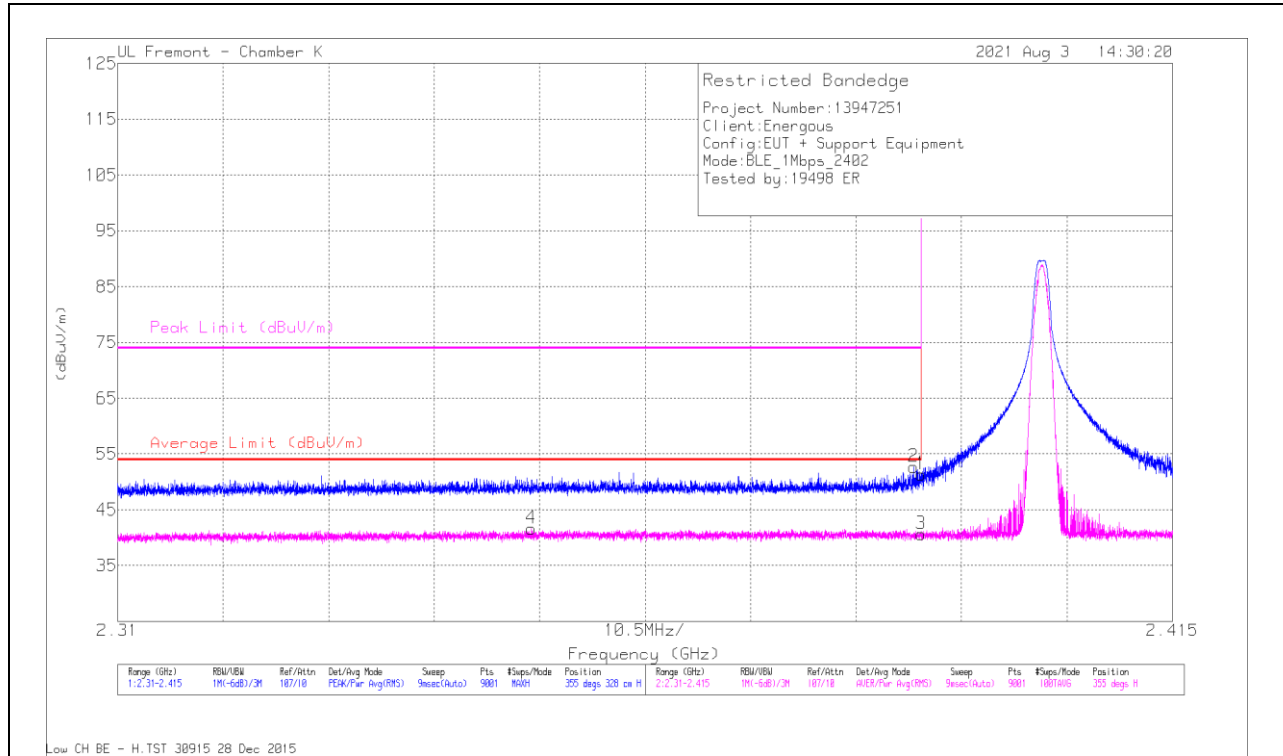

Marker	Frequency (GHz)	Meter Reading (dBuV)	Det	AF T863 (dBm)	Amp/Cbl/Fitr/Pad (dB)	DC Corr (dB)	Corrected Reading (dBuV/m)	Average Limit (dBuV/m)	Margin (dB)	Peak Limit (dBuV/m)	PK Margin (dB)	Azimuth (Degs)	Height (cm)	Polarity
1	* 2.38999	53.39	Pk	32.4	-34.4	0	51.39	-	-	74	-22.61	355	328	H
2	* 2.38924	54.75	Pk	32.4	-34.4	0	52.75	-	-	74	-21.25	355	328	H
3	* 2.38999	40.56	RMS	32.4	-34.4	2.03	40.59	54	-13.41	-	-	355	328	H
4	* 2.35116	41.86	RMS	32.3	-34.6	2.03	41.59	54	-12.41	-	-	355	328	H

\* - indicates frequency in CFR47 Pt 15 / IC RSS-Restricted Band  
 Pk - Peak detector  
 RMS - RMS detection

### VERTICAL RESULT

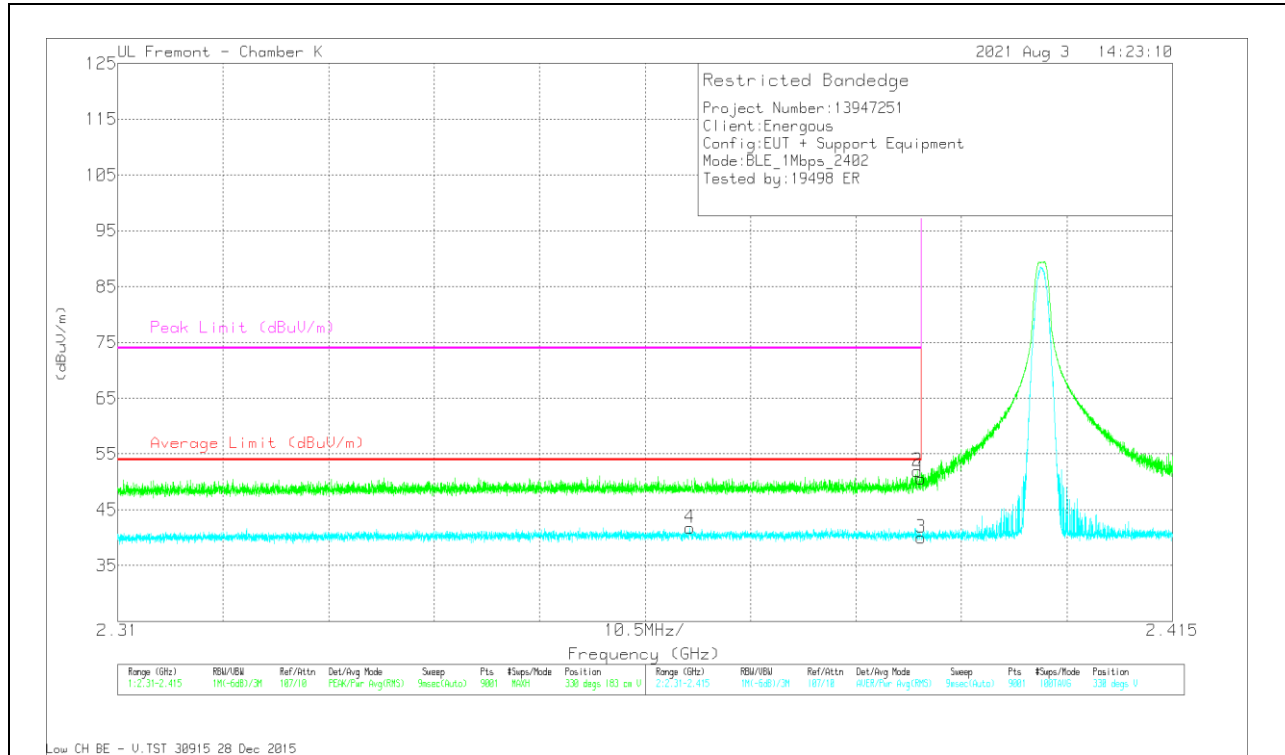

Marker	Frequency (GHz)	Meter Reading (dBuV)	Det	AF T863 (dB/m)	Amp/Cbl/Fitr/Pad (dB)	DC Corr (dB)	Corrected Reading (dBuV/m)	Average Limit (dBuV/m)	Margin (dB)	Peak Limit (dBuV/m)	PK Margin (dB)	Azimuth (Degs)	Height (cm)	Polarity
1	* 2.38999	52.53	Pk	32.4	-34.4	0	50.53	-	-	74	-23.47	330	183	V
2	* 2.38996	53.91	Pk	32.4	-34.4	0	51.91	-	-	74	-22.09	330	183	V
3	* 2.38999	40.03	RMS	32.4	-34.4	2.03	40.06	54	-13.94	-	-	330	183	V
4	* 2.36694	41.89	RMS	32.4	-34.5	2.03	41.82	54	-12.18	-	-	330	183	V

\* - indicates frequency in CFR47 Pt 15 / IC RSS-Restricted Band

Pk - Peak detector

RMS - RMS detection

### BANDEDGE (HIGH CHANNEL)

### HORIZONTAL RESULT

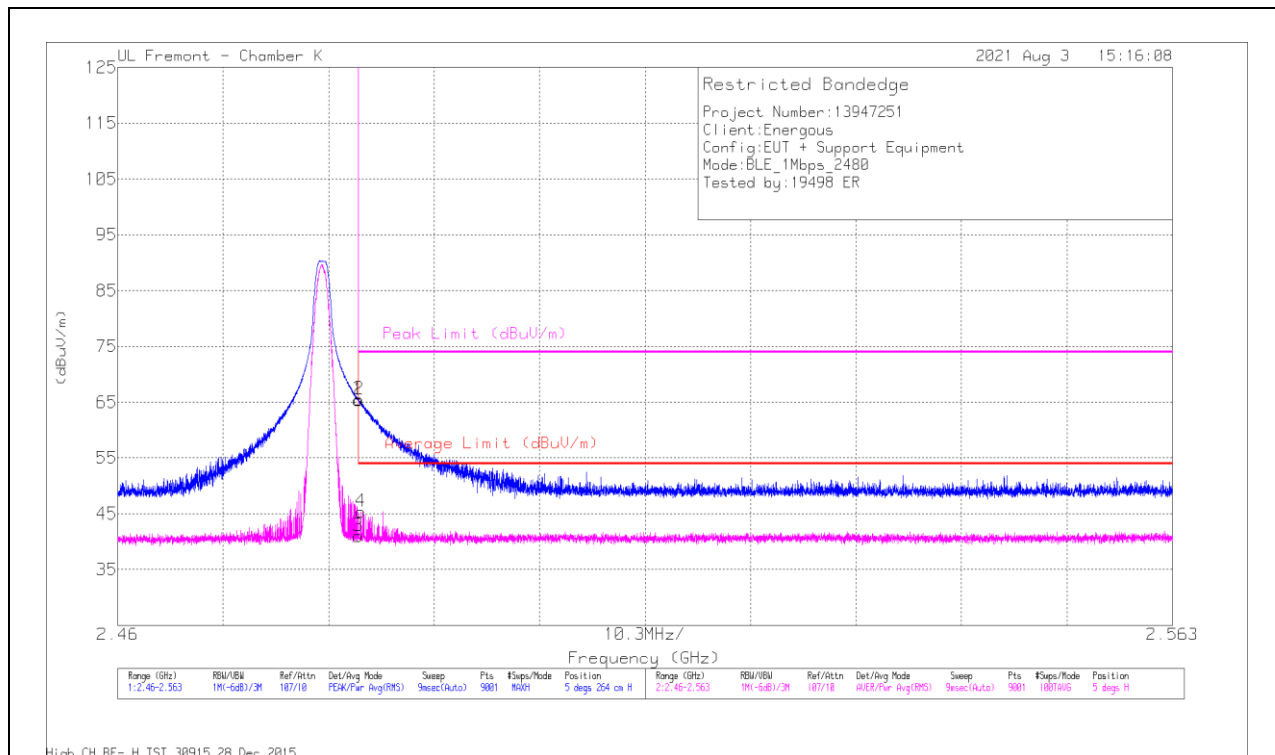

Marker	Frequency (GHz)	Meter Reading (dBuV)	Det	AF T863 (dBm)	Amp/Cbl/Filt/Pad (dB)	DC Corr (dB)	Corrected Reading (dBuV/m)	Average Limit (dBuV/m)	Margin (dB)	Peak Limit (dBuV/m)	PK Margin (dB)	Azimuth (Degs)	Height (cm)	Polarity
1	* 2.48351	66.91	Pk	32.5	-34	0	65.41	-	-	74	-8.59	5	264	H
2	* 2.48359	67.02	Pk	32.5	-34	0	65.52	-	-	74	-8.48	5	264	H
3	* 2.48351	40.44	RMS	32.5	-34	2.03	40.97	54	-13.03	-	-	5	264	H
4	* 2.48377	44.79	RMS	32.5	-34	2.03	45.32	54	-8.68	-	-	5	264	H

\* - indicates frequency in CFR47 Pt 15 / IC RSS-Restricted Band

Pk - Peak detector

RMS - RMS detection

### VERTICAL RESULT

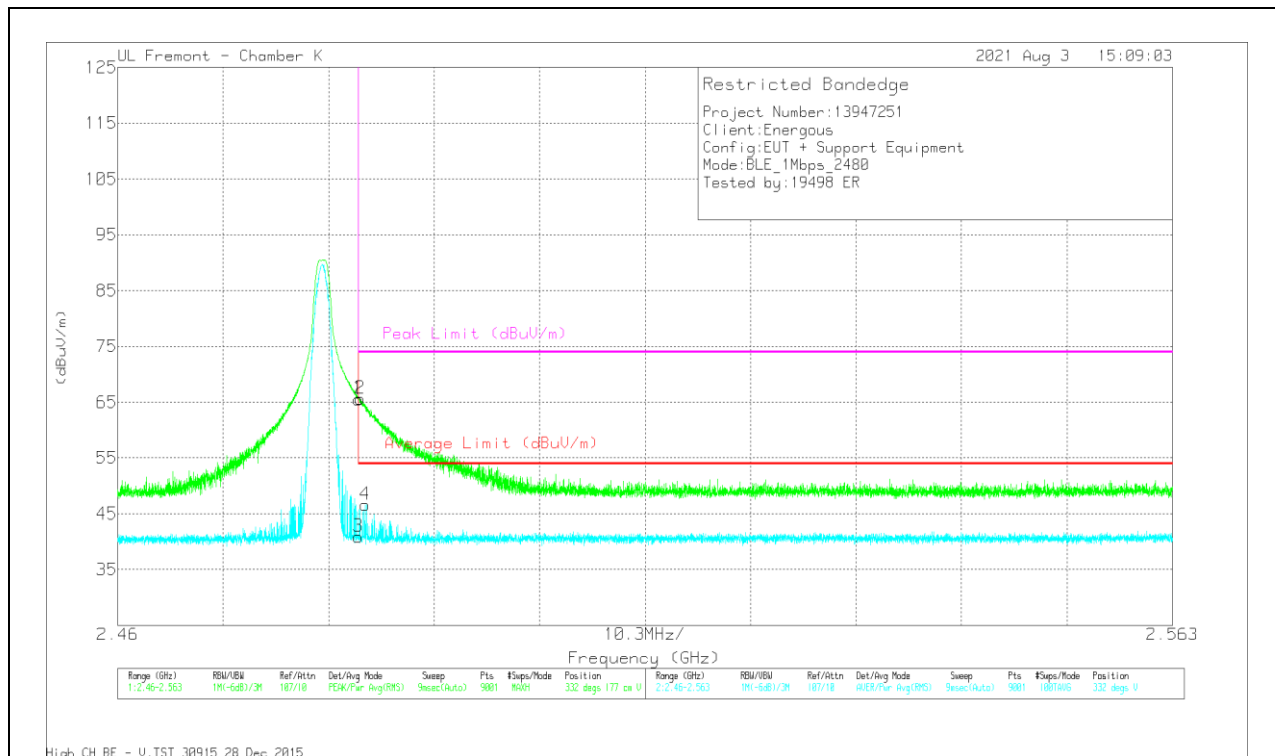

Marker	Frequency (GHz)	Meter Reading (dBuV)	Det	AF T063 (dB/m)	Amp/Cbl/Fitr/Pad (dB)	DC Corr (dB)	Corrected Reading (dBuV/m)	Average Limit (dBuV/m)	Margin (dB)	Peak Limit (dBuV/m)	PK Margin (dB)	Azimuth (Degs)	Height (cm)	Polarity
1	* 2.48351	67.06	Pk	32.5	-34	0	65.56	-	-	74	-8.44	332	177	V
2	* 2.48367	67.18	Pk	32.5	-34	0	65.68	-	-	74	-8.32	332	177	V
3	* 2.48351	40.39	RMS	32.5	-34	2.03	40.92	54	-13.08	-	-	332	177	V
4	* 2.48418	46.1	RMS	32.5	-34	2.03	46.63	54	-7.37	-	-	332	177	V

\* - indicates frequency in CFR47 Pt 15 / IC RSS-Restricted Band  
 Pk - Peak detector  
 RMS - RMS detection

# HARMONICS AND SPURIOUS EMISSIONS

## LOW CHANNEL RESULTS

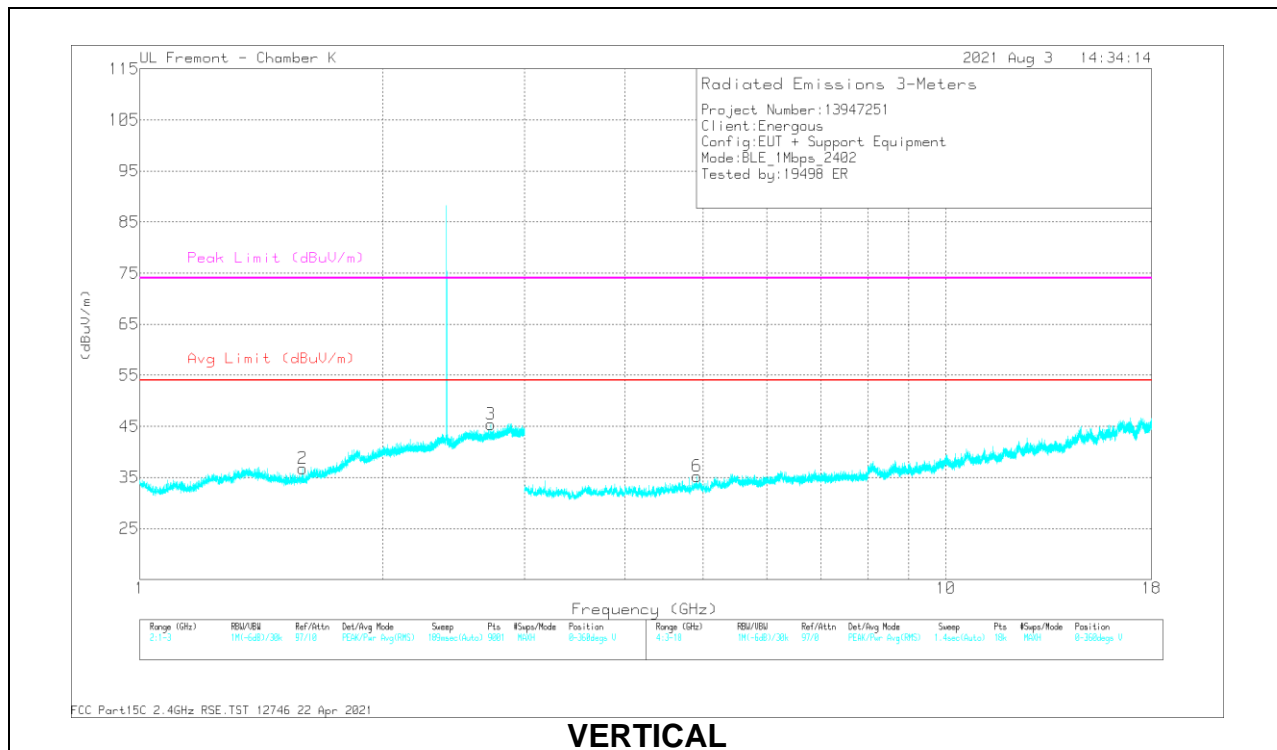
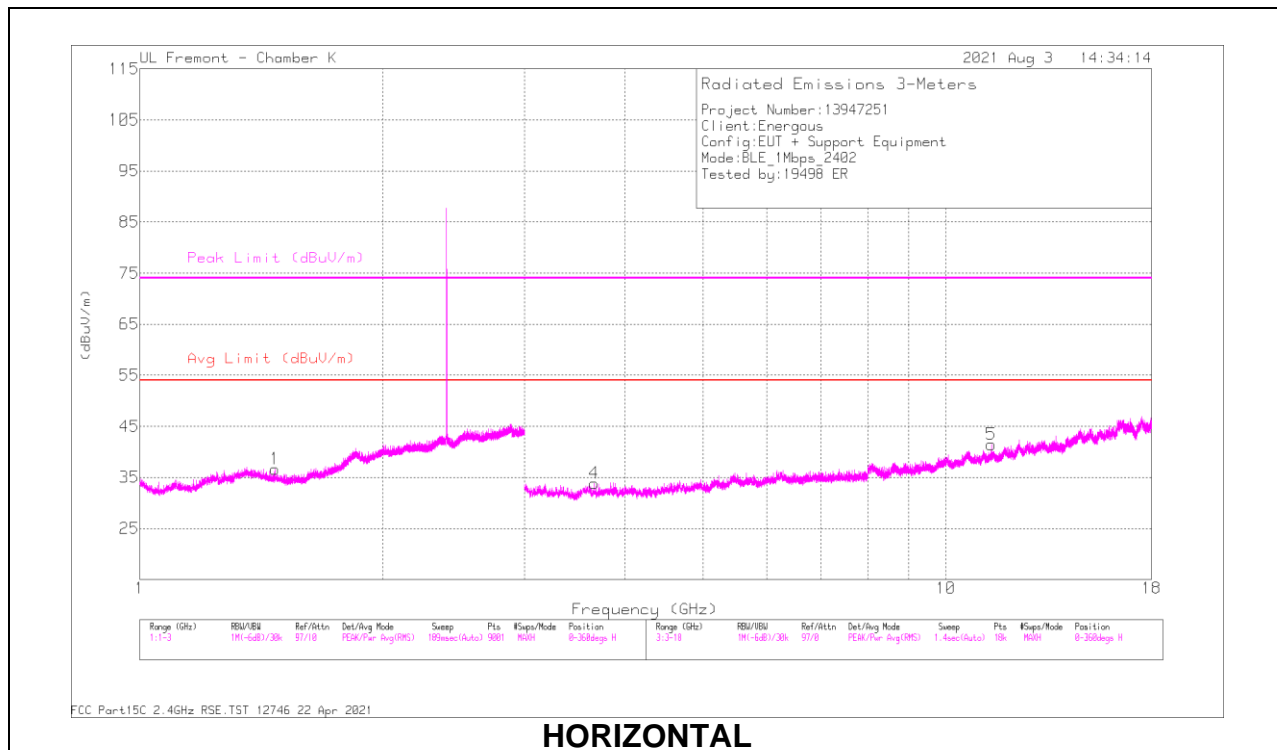

**RADIATED EMISSIONS**

Marker	Frequency (GHz)	Meter Reading (dBuV)	Det	AF T863 (dB/m)	Amp/Cbl/Filtr/ Pad (dB)	DC Corr (dB)	Corrected Reading (dBuV/m)	Avg Limit (dBuV/m)	Margin (dB)	Peak Limit (dBuV/m)	PK Margin (dB)	Azimuth (Degs)	Height (cm)	Polarity
1	* 1.46968	30.16	PK2	28.1	-12.9	0	45.36	-	-	74	-28.64	262	263	H
	* 1.47193	18.69	MAv1	28.1	-12.9	2.03	35.92	54	-18.08	-	-	262	263	H
2	* 1.59164	29.48	PK2	28.1	-12.6	0	44.98	-	-	74	-29.02	233	122	V
	* 1.59157	18.24	MAv1	28.1	-12.6	2.03	35.77	54	-18.23	-	-	233	122	V
3	* 2.72842	31.51	PK2	32.5	-10.4	0	53.61	-	-	74	-20.39	281	198	V
	* 2.72796	19.99	MAv1	32.5	-10.4	2.03	44.12	54	-9.88	-	-	281	198	V
4	* 3.6616	50.02	PK2	33.4	-40.7	0	42.72	-	-	74	-31.28	203	181	H
	* 3.66182	38.37	MAv1	33.4	-40.7	2.03	33.1	54	-20.9	-	-	203	181	H
5	* 11.39299	45.86	PK2	38.1	-34.9	0	49.06	-	-	74	-24.94	104	237	H
	* 11.3867	34.44	MAv1	38.1	-35	2.03	39.57	54	-14.43	-	-	104	237	H
6	* 4.91523	49.41	PK2	34.4	-40	0	43.81	-	-	74	-30.19	225	239	V
	* 4.91246	37.73	MAv1	34.4	-40	2.03	34.16	54	-19.84	-	-	225	239	V

\* - indicates frequency in CFR47 Pt 15 / IC RSS-Restricted Band

PK2 - KDB558074 Method: Maximum Peak

MAv1 - KDB558074 Option 1 Maximum RMS Average

### MID CHANNEL RESULTS

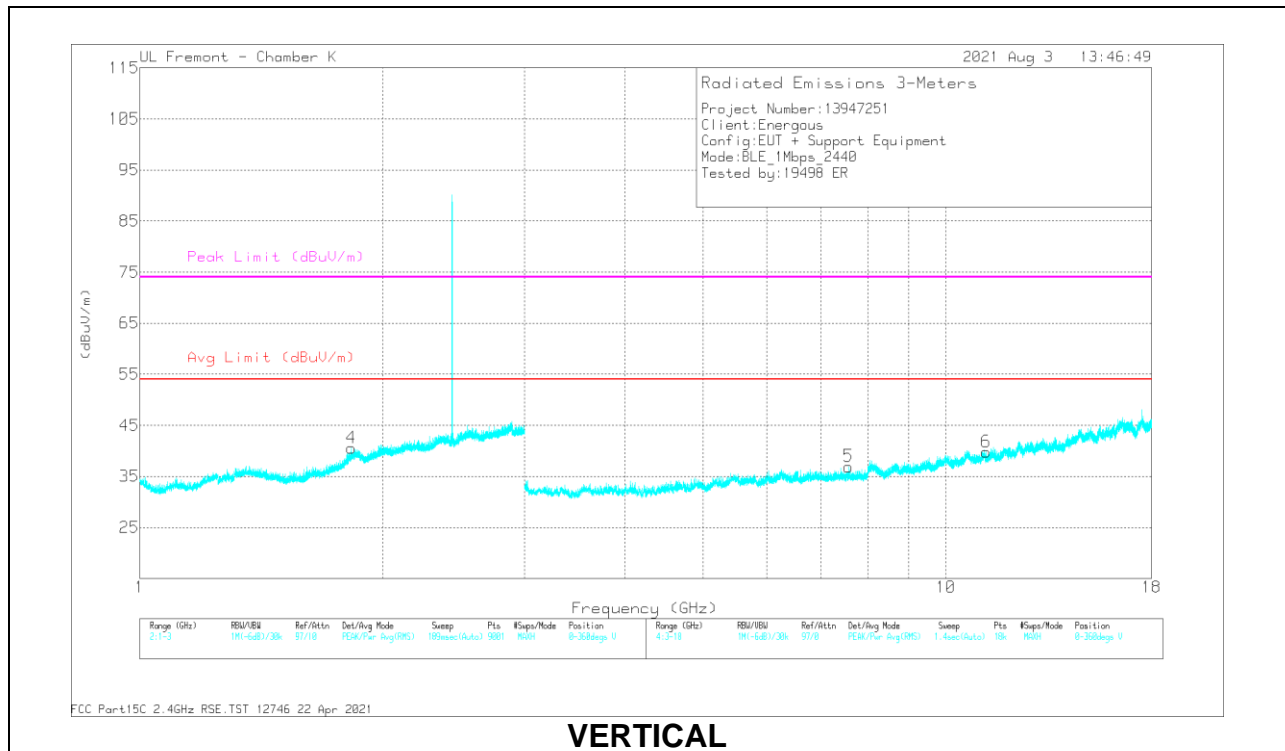
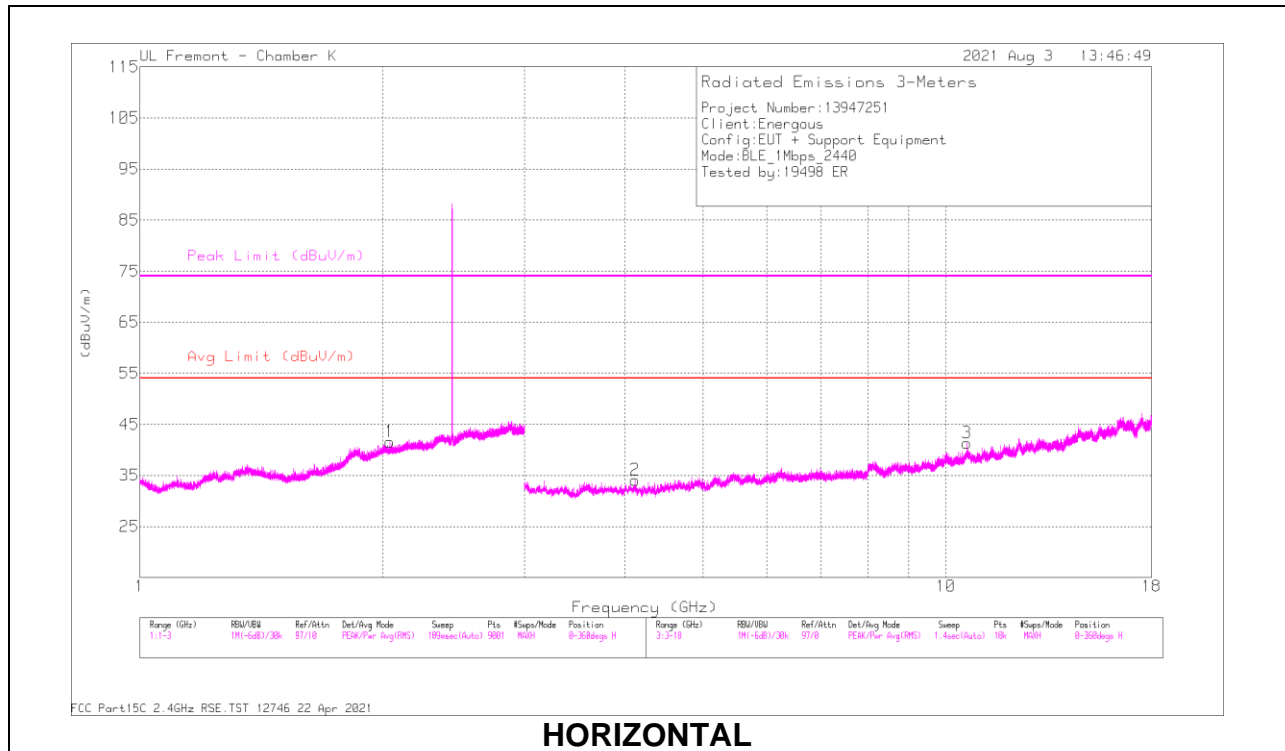



**RADIATED EMISSIONS**

Marker	Frequency (GHz)	Meter Reading (dBuV)	Det	AF T863 (dB/m)	Amp/Cbl/Fitr/ Pad (dB)	DC Corr (dB)	Corrected Reading (dBuV/m)	Avg Limit (dBuV/m)	Margin (dB)	Peak Limit (dBuV/m)	PK Margin (dB)	Azimuth (Degs)	Height (cm)	Polarity
1	2.04224	18.14	PK2	31.3	-11.7	0	37.74	-	-	-	-	266	241	H
4	1.83018	29.97	PK2	30.6	-12.2	0	48.37	-	-	-	-	283	132	V
2	* 4.11496	50.8	PK2	33.7	-41	0	43.5	-	-	74	-30.5	244	270	H
	* 4.11777	39.11	MAv1	33.7	-41.1	2.03	33.74	54	-20.26	-	-	244	270	H
3	* 10.62272	47.28	PK2	38	-35.5	0	49.78	-	-	74	-24.22	341	362	H
	* 10.62161	35.77	MAv1	38	-35.5	2.03	40.3	54	-13.7	-	-	341	362	H
5	* 7.57047	46.81	PK2	36.1	-37.2	0	45.71	-	-	74	-28.29	299	231	V
	* 7.56823	35.14	MAv1	36.1	-37.2	2.03	36.07	54	-17.93	-	-	299	231	V
6	* 11.22738	45.01	PK2	37.9	-34.6	0	48.31	-	-	74	-25.69	34	294	V
	* 11.22986	34.12	MAv1	37.9	-34.6	2.03	39.45	54	-14.55	-	-	34	294	V

\* - indicates frequency in CFR47 Pt 15 / IC RSS-Restricted Band  
 PK2 - KDB558074 Method: Maximum Peak  
 MAv1 - KDB558074 Option 1 Maximum RMS Average

### HIGH CHANNEL RESULTS

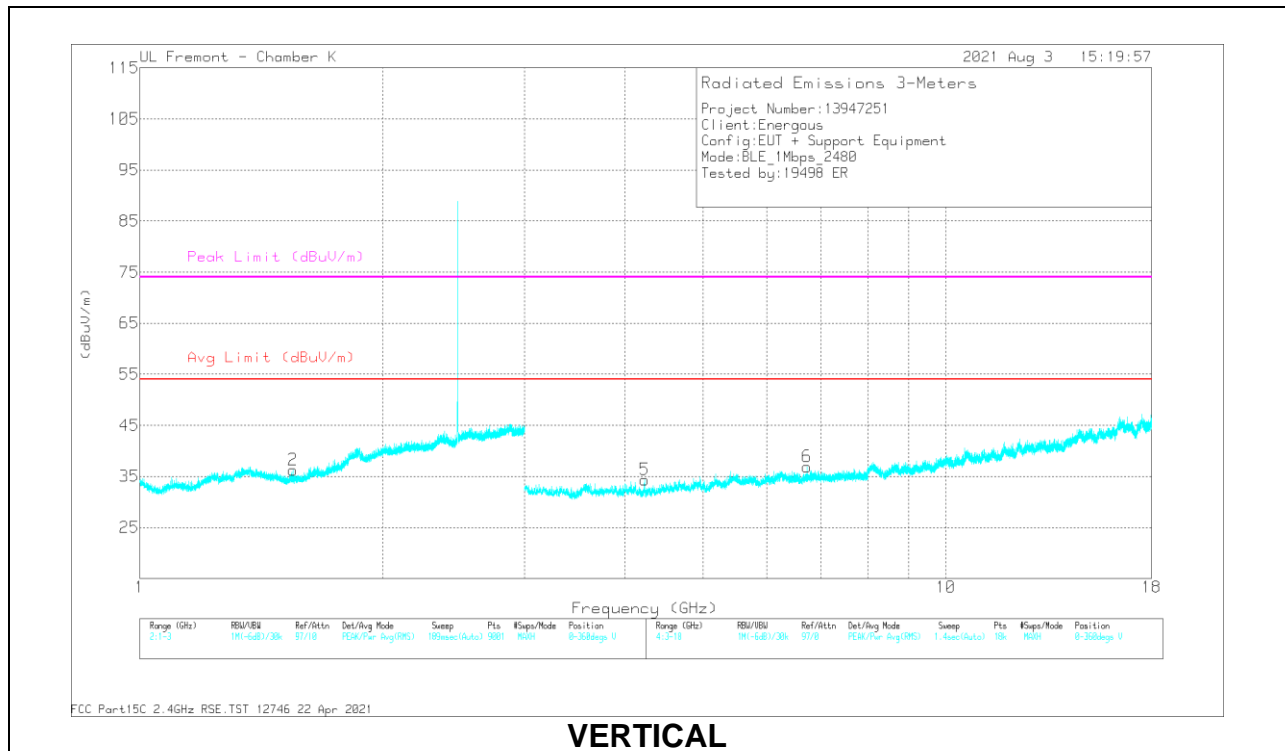
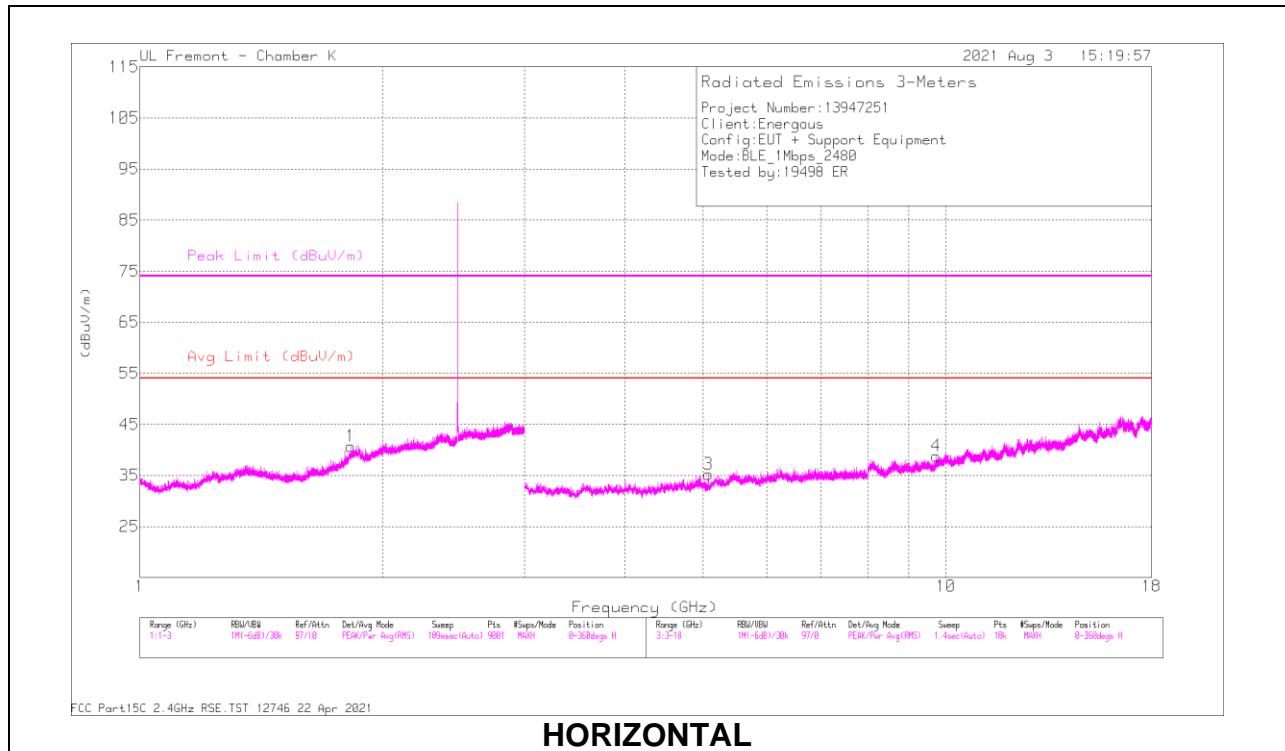

**RADIATED EMISSIONS**

Marker	Frequency (GHz)	Meter Reading (dBuV)	Det	AF T863 (dB/m)	Amp/Cbl/Filtr/ Pad (dB)	DC Corr (dB)	Corrected Reading (dBuV/m)	Avg Limit (dBuV/m)	Margin (dB)	Peak Limit (dBuV/m)	PK Margin (dB)	Azimuth (Degs)	Height (cm)	Polarity
1	1.82631	30.13	PK2	30.5	-12.2	0	48.43	-	-	-	-	44	165	H
2	* 1.54722	29.66	PK2	27.9	-12.7	0	44.86	-	-	74	-29.14	314	361	V
	* 1.54739	18.2	MAv1	27.9	-12.7	2.03	35.43	54	-18.57	-	-	314	361	V
4	9.7367	45.91	PK2	37	-35.7	0	47.21	-	-	-	-	107	110	H
3	* 5.08086	48.55	PK2	34.4	-39.6	0	43.35	-	-	74	-30.65	204	170	H
	* 5.07848	37.03	MAv1	34.4	-39.6	2.03	33.86	54	-20.14	-	-	204	170	H
6	6.72675	47.26	PK2	36	-37.7	0	45.56	-	-	-	-	273	324	V
5	* 4.22889	49.92	PK2	33.6	-40.9	0	42.62	-	-	74	-31.38	326	135	V
	* 4.23051	38.39	MAv1	33.6	-40.9	2.03	33.12	54	-20.88	-	-	326	135	V

\* - indicates frequency in CFR47 Pt 15 / IC RSS-Restricted Band  
 PK2 - KDB558074 Method: Maximum Peak  
 MAv1 - KDB558074 Option 1 Maximum RMS Average

### 10.3. WORST CASE BELOW 30MHZ

#### SPURIOUS EMISSIONS BELOW 30 MHz (WORST-CASE CONFIGURATION)

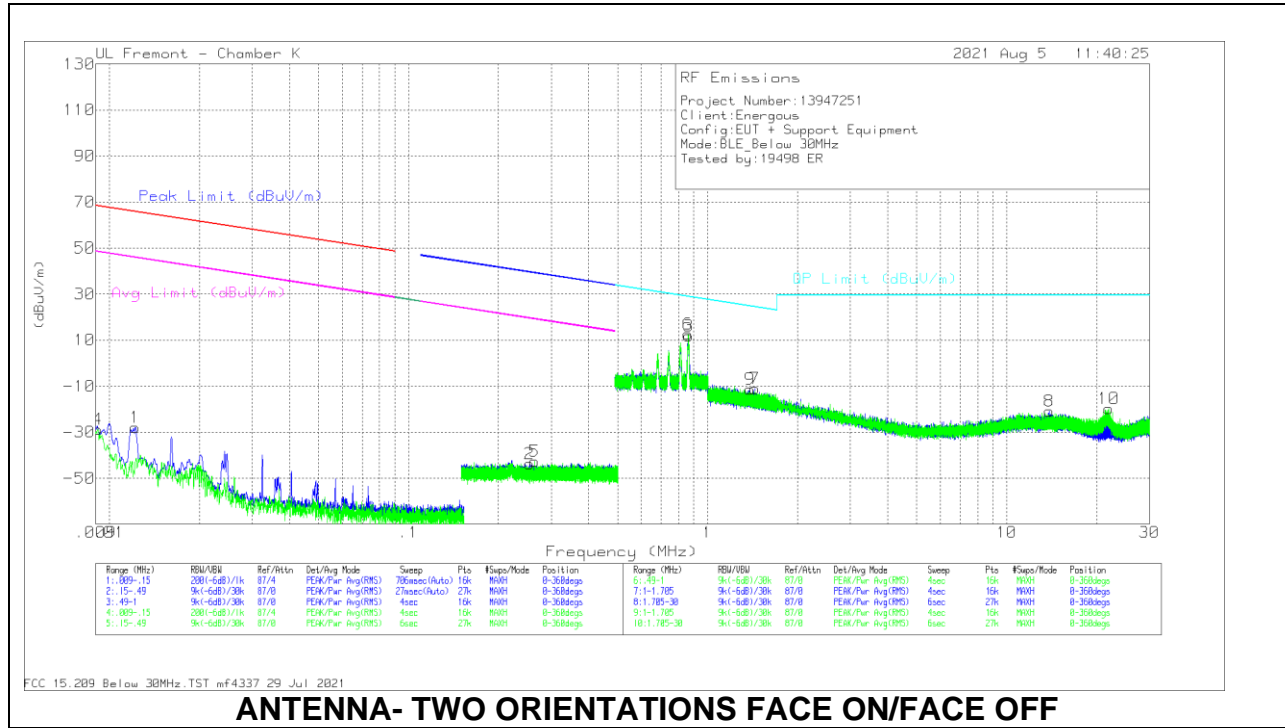

#### ANTENNA- TWO ORIENTATIONS FACE ON/FACE OFF

#### Below 30MHz Data

Marker	Frequency (MHz)	Meter Reading (dBuV)	Det	Loop Antenna (E ACF)	Amp/Cbl (dB)	Dist Corr 300m	Corrected Reading (dBuV/m)	Peak Limit (dBuV/m)	PK Margin (dB)	Avg Limit (dBuV/m)	Margin (dB)	Azimuth (Degs)
1	.01221	23.42	Pk	60.1	-31.5	-80	-27.98	65.85	-93.83	45.85	-73.83	0-360
2	.25427	12.26	Pk	56.2	-32.2	-80	-43.74	39.51	-83.25	19.51	-63.25	0-360
4	.00914	21.12	Pk	61.3	-31.3	-80	-28.88	68.36	-97.24	48.36	-77.24	0-360
5	.26384	13.3	Pk	56.2	-32.2	-80	-42.7	39.19	-81.89	19.19	-61.89	0-360

Pk - Peak detector

Marker	Frequency (MHz)	Meter Reading (dBuV)	Det	Loop Antenna (E ACF)	Amp/Cbl (dB)	Dist Corr 30m (dB) 40Log	Corrected Reading (dBuV/m)	QP Limit (dBuV/m)	Margin (dB)	Azimuth (Degs)
3	.86197	27.94	Pk	56.2	-32.2	-40	11.94	28.91	-16.97	0-360
6	.86024	28.57	Pk	56.2	-32.2	-40	12.57	28.93	-16.36	0-360
7	1.43657	16.66	Pk	44.4	-32.1	-40	-11.04	24.48	-35.52	0-360
8	13.86809	17.23	Pk	33.8	-31.8	-40	-20.77	29.5	-50.27	0-360
9	1.38667	16.09	Pk	44.7	-32.1	-40	-11.31	24.79	-36.1	0-360
10	21.96389	18.01	Pk	33.7	-31.6	-40	-19.89	29.5	-49.39	0-360

Pk - Peak detector

### 10.4. WORST CASE BELOW 1 GHZ

#### SPURIOUS EMISSIONS 30 TO 1000 MHz (WORST-CASE CONFIGURATION)

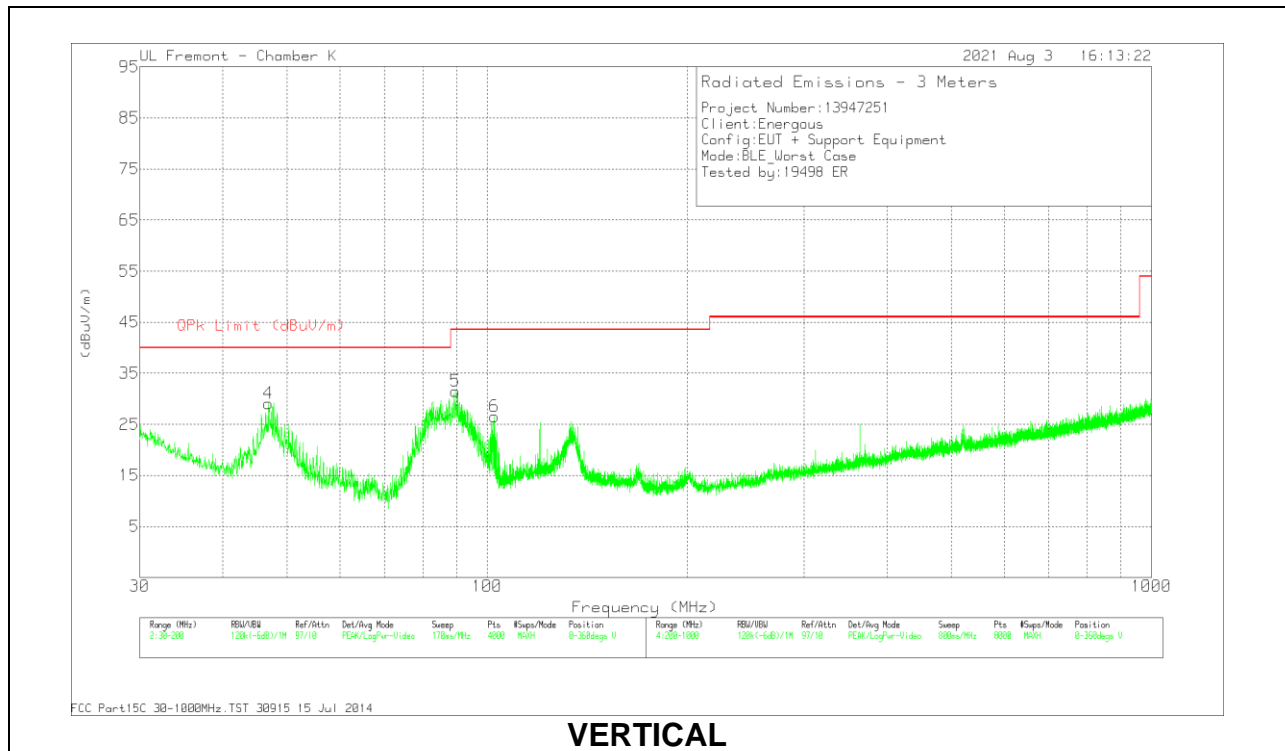
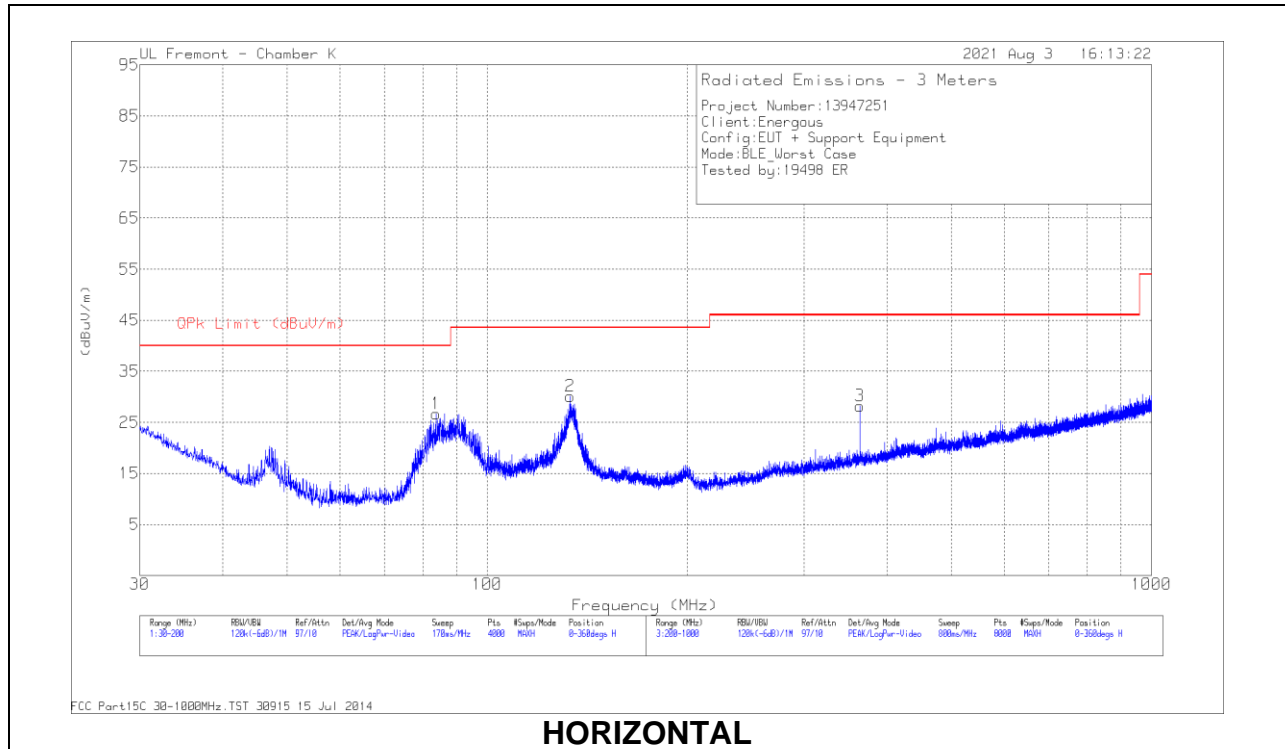

**Below 1GHz Data**

Marker	Frequency (MHz)	Meter Reading (dBuV)	Det	AF 81560 (dB/m)	Amp/Cbl (dB)	Corrected Reading (dBuV/m)	QPk Limit (dBuV/m)	Margin (dB)	Azimuth (Degs)	Height (cm)	Polarity
1	83.7339	44.23	Pk	13.5	-31.1	26.63	40	-13.37	0-360	393	H
2	* 133.3442	41.05	Pk	19.7	-30.7	30.05	43.52	-13.47	0-360	197	H
4	46.339	37.97	Qp	16.1	-31.4	22.67	40	-17.33	100	99	V
5	89.5579	48.92	Pk	13.6	-31	31.52	43.52	-12	0-360	100	V
6	102.4813	40.53	Pk	16.9	-30.9	26.53	43.52	-16.99	0-360	100	V
3	363.9213	36.39	Pk	21.4	-29.6	28.19	46.02	-17.83	0-360	100	H

Pk - Peak detector  
 Qp - Quasi-Peak detector

## 10.5. WORST CASE 18-26 GHZ

### SPURIOUS EMISSIONS 18-26 GHZ (WORST-CASE CONFIGURATION)

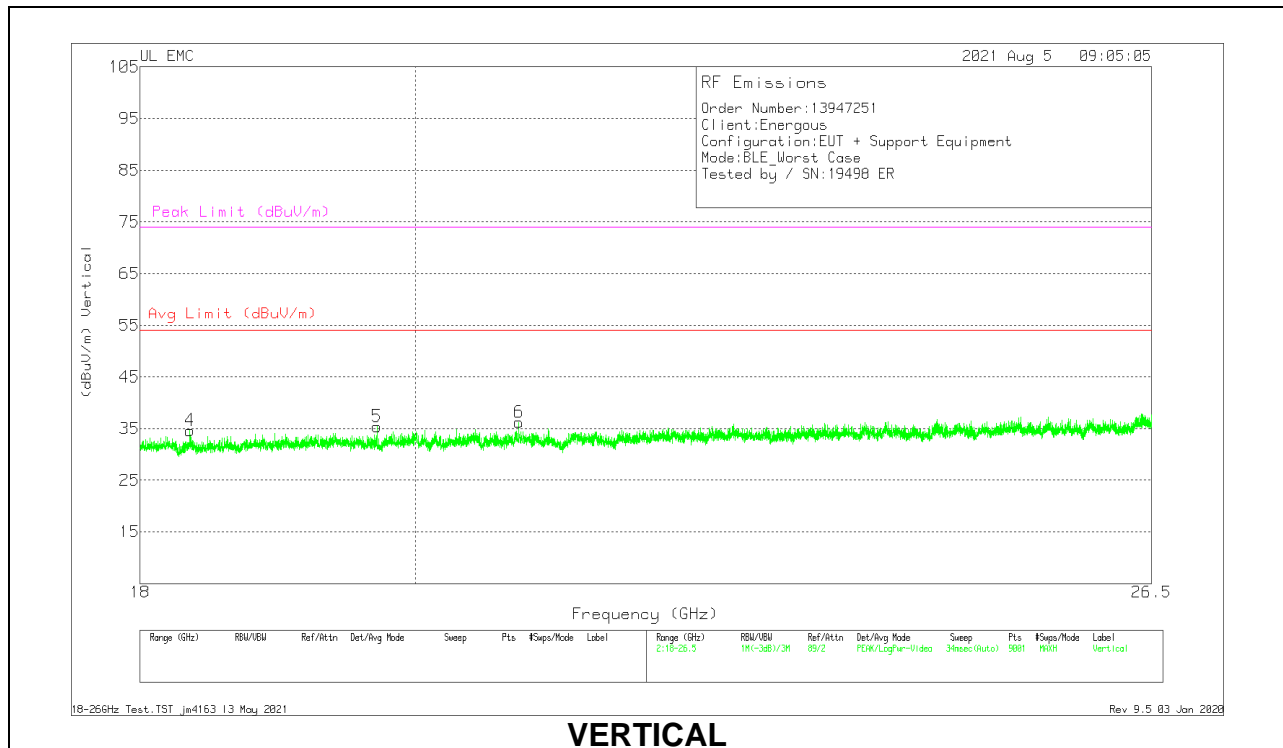
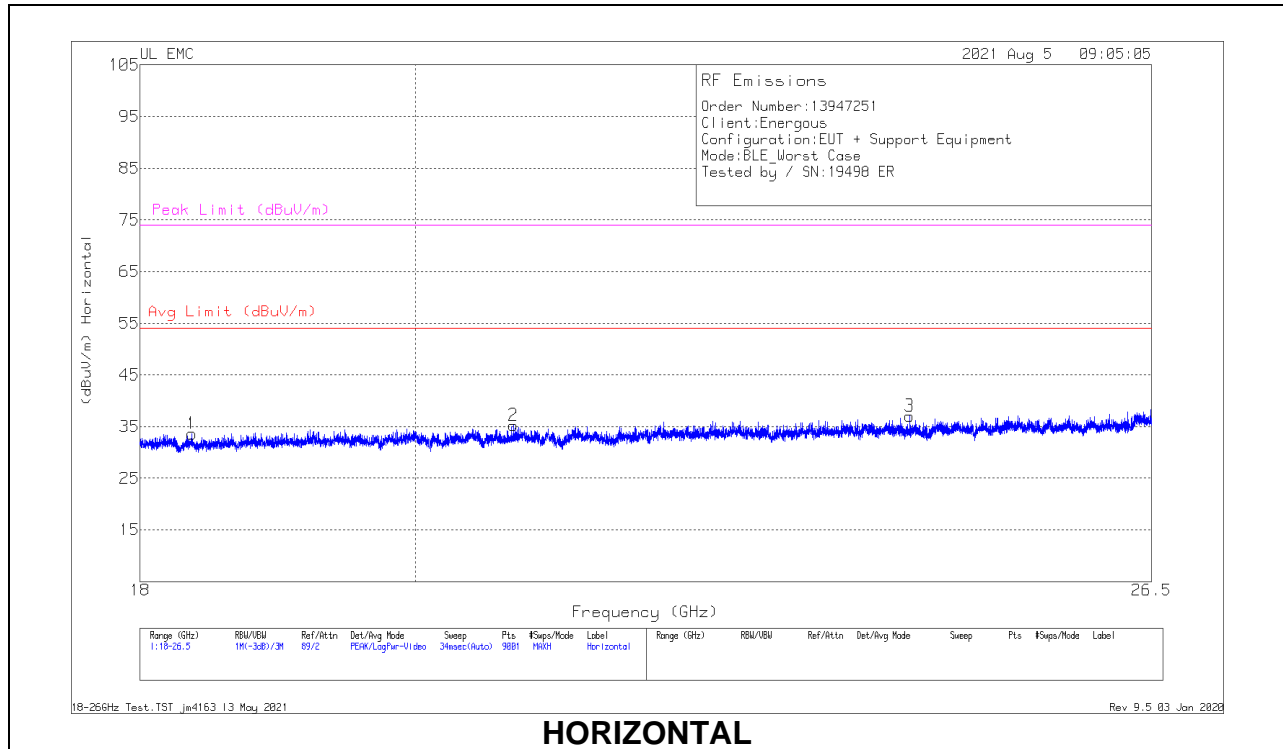

**18 – 26GHz DATA**

Marker	Frequency (GHz)	Meter Reading (dBuV)	Det	18-26GHz Horn	Amp/Cbl (dB)	Dist Corr (dB)	Corrected Reading (dBuV/m)	Avg Limit (dBuV/m)	Margin (dB)	Peak Limit (dBuV/m)	PK Margin (dB)
1	18.35983	69.82	Pk	32.6	-59.3	-9.5	33.62	-	-	74	-40.38
2	20.76155	68.13	Pk	33.4	-56.8	-9.5	35.23	-	-	74	-38.77
3	24.15872	69.03	Pk	34.6	-57.1	-9.5	37.03	-	-	74	-36.97
4	18.34567	70.83	Pk	32.7	-59.4	-9.5	34.63	-	-	74	-39.37
5	19.70755	68.18	Pk	33.3	-56.6	-9.5	35.38	-	-	74	-38.62
6	20.805	69.14	Pk	33.6	-57	-9.5	36.24	-	-	74	-37.76

Pk - Peak detector



## 11. AC POWER LINE CONDUCTED EMISSIONS

### LIMITS

FCC §15.207 (a)

Frequency of Emission (MHz)	Conducted Limit (dB $\mu$ V)	
	Quasi-peak	Average
0.15-0.5	66 to 56 *	56 to 46 *
0.5-5	56	46
5-30	60	50

\*Decreases with the logarithm of the frequency.

### RESULTS

### LINE 1 RESULTS

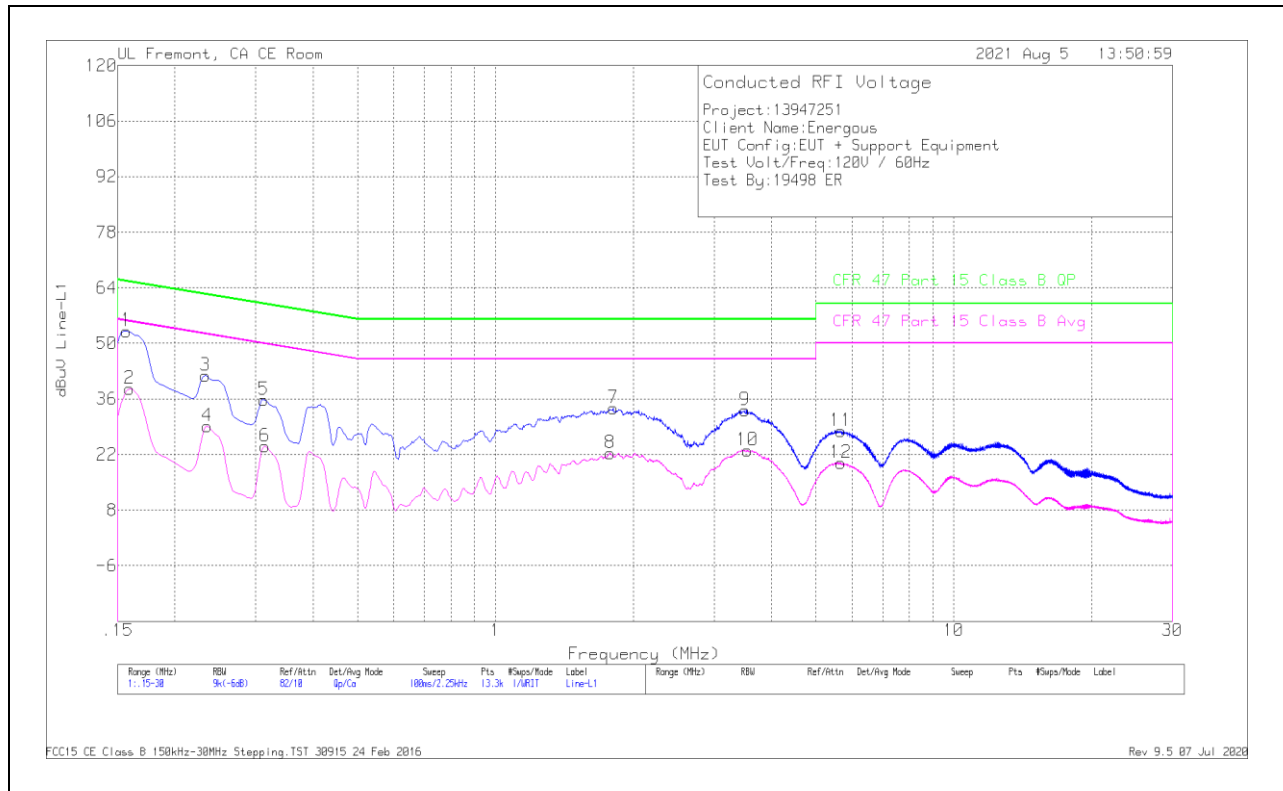

Range 1: Line-L1 .15 - 30MHz											
Marker	Frequency (MHz)	Meter Reading (dBuV)	Det	PRE018644 6 L1	LC Cables C1&C3 dB	TekBox Limiter TBFL1 Model 207	Corrected Reading dBuV	CFR 47 Part 15 Class B QP	QP Margin (dB)	CFR 47 Part 15 Class B Avg	Av(CISPR)Margin (dB)
2	.159	29.09	Ca	.1	0	9.4	38.59	-	-	55.52	-16.93
4	.2355	19.82	Ca	0	0	9.3	29.12	-	-	52.25	-23.13
6	.31425	14.81	Ca	0	0	9.3	24.11	-	-	49.86	-25.75
8	1.779	12.94	Ca	0	.1	9.3	22.34	-	-	46	-23.66
10	3.55088	13.64	Ca	0	.1	9.3	23.04	-	-	46	-22.96
12	5.66475	10.55	Ca	0	.1	9.3	19.95	-	-	50	-30.05
1	.15675	43.63	Qp	.1	0	9.4	53.13	65.63	-12.5	-	-
3	.23325	32.52	Qp	0	0	9.3	41.82	62.33	-20.51	-	-
5	.312	26.48	Qp	0	0	9.3	35.78	59.92	-24.14	-	-
7	1.80825	24.26	Qp	0	.1	9.3	33.66	56	-22.34	-	-
9	3.50475	23.81	Qp	0	.1	9.3	33.21	56	-22.79	-	-
11	5.6715	18.53	Qp	0	.1	9.3	27.93	60	-32.07	-	-

Qp - Quasi-Peak detector  
 Ca - CISPR average detection

### LINE 2 RESULTS

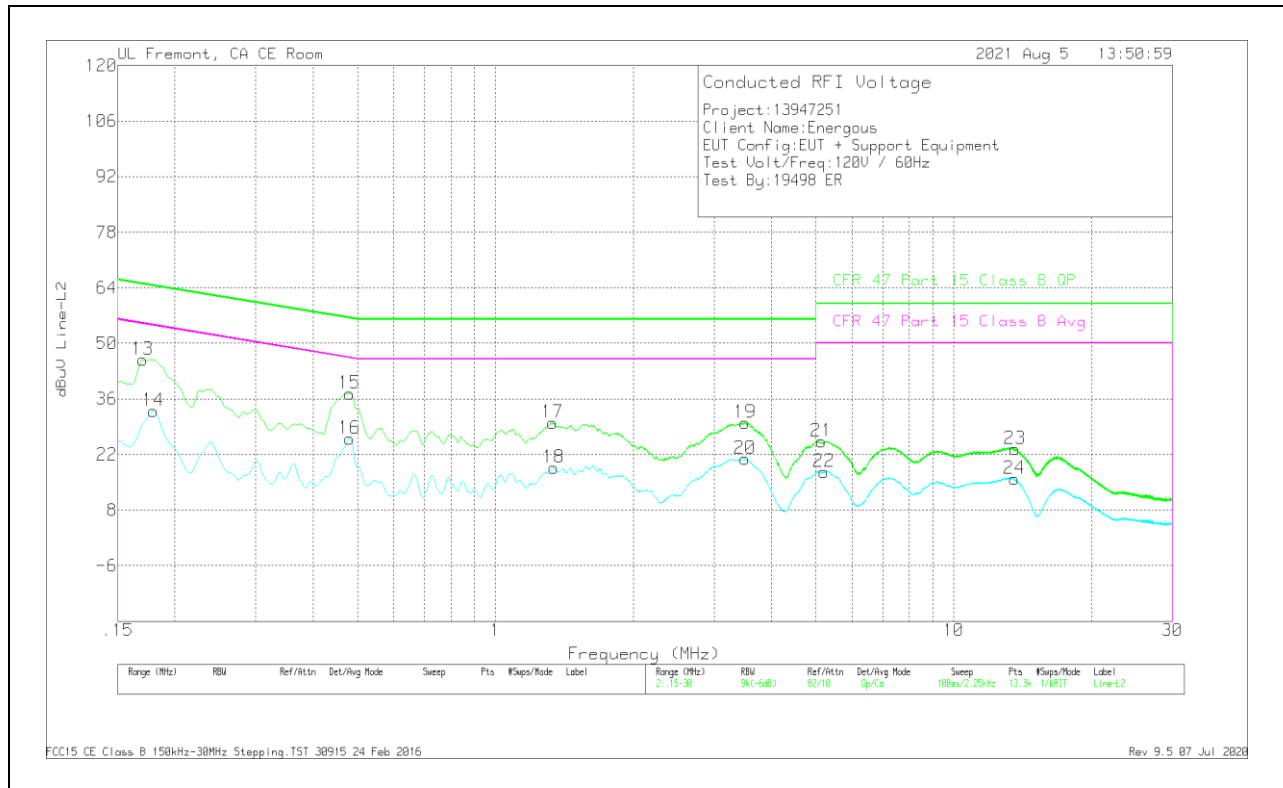

Range 2: Line-L2 .15 - 30MHz											
Marker	Frequency (MHz)	Meter Reading (dBuV)	Det	PRE018644 6 L2	LC Cables C2&C3 dB	TekBox Limiter TBFL1 Model 207	Corrected Reading dBuV	CFR 47 Part 15 Class B QP	QP Margin (dB)	CFR 47 Part 15 Class B Avg	Av(CISPR)M argin (dB)
14	.17925	23.63	Ca	0	0	9.4	33.03	-	-	54.52	-21.49
16	.48075	16.78	Ca	0	0	9.3	26.08	-	-	46.33	-20.25
18	1.3425	9.31	Ca	0	.1	9.3	18.71	-	-	46	-27.29
20	3.50363	11.52	Ca	0	.1	9.3	20.92	-	-	46	-25.08
22	5.21475	8.19	Ca	0	.1	9.3	17.59	-	-	50	-32.41
24	13.56	6.25	Ca	.1	.2	9.3	15.85	-	-	50	-34.15
13	.17025	36.56	Qp	0	0	9.4	45.96	64.95	-18.99	-	-
15	.48075	28.12	Qp	0	0	9.3	37.42	56.33	-18.91	-	-
17	1.3335	20.68	Qp	0	.1	9.3	30.08	56	-25.92	-	-
19	3.50925	20.66	Qp	0	.1	9.3	30.06	56	-25.94	-	-
21	5.14725	15.97	Qp	0	.1	9.3	25.37	60	-34.63	-	-
23	13.6005	13.84	Qp	.1	.2	9.3	23.44	60	-36.56	-	-

Qp - Quasi-Peak detector  
 Ca - CISPR average detection