

Loop Antenna specification

Dongguan Yinzhe Electronic Technology Co., LTD

Factory address: Building D, No. 40, Fulong Education Road, Shipai Town, Dongguan City

**SPECIFICATION**

DESC	Loop Antenna <b>G43.5*0.8-20.5-*0.08*48P-10 TS*6.6UH-L17MM+BJ</b>	Rev: A.0	CUST:	
			CUST P/N:	

1.DIMENSION:(mm)

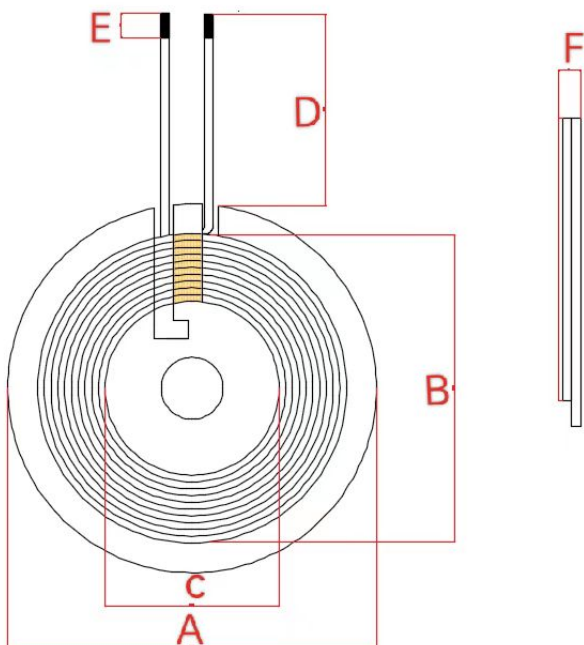

A	43.5±0.3
B	38.5±0.5
C	20.5±0.5
D	17 ±2
E	3±2
F	1.6±0.15
G	
H	
I	
K	

Note:

1. Cross out line;
2. The coil is attached with double slot magnetic sheet, the magnetic sheet size is 43.5±0.5mm, and the thickness is 0.8±0.05mm.
3. Stick back glue on the back of the magnet

2.Winding Specification:

NO.	TERMINAL		WIRE	Turns	Winding Direction
1	S	F	enameled wire 0.08*48P	10Ts	CCW

3.ELECTRICAL CHARACTERISTICS:

TEMPERATURE:25±10°C, RELATIVE HUMIDITY:65±20%

NO.	ITEM	TERMINAL	SPECIFICATION	TEST FREQUENCY	TEST EQUIPMENTS
1	IND.	S-F	3.7uH ±10%	100KHz/1.0V	LCZ METER 1062B
2	IND.	S-F	6.6H ±10%	100KHz/1.0V	LCZ METER 1062B
3	DCR	S-F	≤100m Ω		LCZ METER 502B