

50mm

86mm

VIVITAR

**BLUETOOTH SPEAKER
Instruction Manual**



FCC ID: 2ADM5-VZ60027BT



Introduction

Thank you for purchasing your Vivitar Bluetooth Speaker, item VZ60027BT. You can use your speaker with iPads, iPhones, iPods and many other types of smartphones and Bluetooth devices to stream music and enjoy hands-free calling. In order to get the best results when using this device, please read this manual first before using.

Package Contents

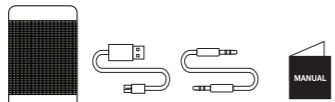

Specifications

Bluetooth Version: 4.1
Bluetooth Range: Up to 32.8 feet (10 meters)
Power Supply: DC 5V
Battery Type: 1,200 mAh, 3.7V, Lithium-Ion Battery
Charge Time: Approximately 2 Hours
Driver Diameter: 52mm
Impedance: 4 Ohms

A Quick Look at Your Device

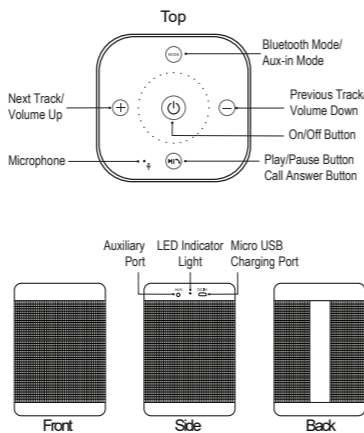

Charging Your Speaker

Your speaker has a built-in, rechargeable lithium-ion battery. To avoid damage, do not attempt to remove the battery. The full performance of the battery is only achieved after a few charging-discharging cycles. Charge the battery fully before first use. To do so, follow the steps below:

1. Connect one end of the included Micro USB charging cable to the Micro USB charging port on your speaker. Then plug the other end of the Micro USB charging cable into a USB port on your computer or a suitable power adapter in order to recharge the internal rechargeable battery.

NOTE: The internal battery of your speaker takes approximately two hours to charge when completely drained. To maximize performance, it is recommended to charge the battery for six hours before initial use.

2. When the battery is charging, the LED indicator light will turn red. The LED indicator light will turn blue when the battery is fully charged. Unplug when charging is complete.

NOTE: Overcharging could reduce the life of the battery. A charged battery will lose its capacity if it is not used on a regular basis.

Important!
To avoid a complete discharge of the battery, charge your speaker at least once every six months.

Pairing Your Speaker

Your speaker can be paired with most Bluetooth devices including iPads, iPhones, iPod Touches, and most smartphones, laptops and tablets. In order to pair your speaker with a phone, follow the steps below:

1. Press and hold the ON/OFF button until your speaker powers on. The LED indicator light on your speaker will flash blue, blinking rapidly. This indicates that your speaker is in pairing mode.

2. Go to the Bluetooth Manager of your Bluetooth device.

3. Search Bluetooth devices and select "VZ60027 WL Speaker" to start connecting.

4. Enter "0000" if your device asks for the PIN code.

5. Once paired, the LED indicator light will slowly blink blue every few seconds.

Note: If the speaker does not automatically enter into Bluetooth mode, press the Mode/Pair button to initiate pairing.

Using Your Speaker

Powering Your Speaker On and OFF
1. Press and hold the ON/OFF button in order to power on your speaker. If you have already paired your speaker to your Bluetooth device, they will automatically remain paired each time you power on your speaker.
2. Press and hold the ON/OFF button in order to power off your speaker.

Listening to Music
• Play/Pause Button: Press to play or pause a track.
• Quickly tap the "NEXT TRACK/VOLUME +" button to advance to the next song in a playlist.
• Quickly tap the "PREVIOUS TRACK/VOLUME -" button to go back to the previous song in a playlist.
• Press and hold the "NEXT TRACK/VOLUME +" button to increase the volume
• Press and hold the "PREVIOUS TRACK/VOLUME -" button to decrease the volume.

Note: You can also adjust volume and playback settings on your phone or connected audio device. When listening to music from a device that is connected to the speaker's Auxiliary Port, the buttons on the speaker may not function to advance to the next track or return to the previous track.

Using the Phone Function
• Answering a Call: Quickly press the ANSWER button to answer an incoming call.
• Reject an Incoming Call: Press and hold the ANSWER button to reject an incoming call.
• Ending a Call: Quickly press the ANSWER button to end a call.

Note: The phone function can only be used when there is a Bluetooth connection between your speaker and phone.

Maintenance and Care

-Before using your speaker, inspect the ports and jacks to make sure that they are clear of dust and debris before charging or inserting an AUX cable.

-Use a soft cloth to clean your speaker. Never use any harsh chemicals or detergents. Make sure your speaker is dry before using.

-When your speaker is not in use, it should be stored in a cool, dry place.

-Never tug or yank on the USB cable or AUX cable while they are connected to your speaker. Connect and disconnect these cables as carefully as possible.

-Never expose your speaker to high temperatures, extreme cold, high humidity or excessive moisture or water.

-Please recycle or dispose of your speaker properly based on the laws and rules of your municipality. Contact local recycling facilities and/or the manufacturer of your speaker for further information.



Important Safety Precautions

When using your Vivitar Bluetooth Speaker, basic safety precautions should always be followed, including the following:

1. READ ALL INSTRUCTIONS BEFORE USING YOUR SPEAKER.
2. Do not use your speaker near water. Clean using a soft cloth or paper towel.
3. Do not place your speaker on any wet surfaces.
4. Do not allow children or the infirm to play with your speaker without adult supervision.
5. Do not expose your speaker to excessive heat, flames or fire.
6. Always press all buttons carefully. Do not manhandle your speaker.
7. Do not use in extremely dry environments, as this can lead to static discharge during usage.
8. Do not expose your speaker to temperatures above 40°C. Keep out of direct sunlight.
9. Do not attempt to repair this product yourself. Contact a qualified service center if your speaker is in need of service.
10. Do not drop, puncture or expose your speaker to excessive trauma.
11. Your speaker is not intended for commercial use.
12. Do not place near objects that generate a strong magnetic field.
13. Use only the supplied chargers and cables. Unplug this device when not in use for long periods of time or during lightning storms.

FCC Statement

This device complies with the part 15 of the FCC rules. Operation is subject to the following two conditions: (1) this device may not cause harmful interference, and (2) this device must accept any interference received, including interference that may cause undesired operation.

Caution: changes or modifications not expressly approved by the party responsible for compliance could void the user's authority to operate the equipment.

NOTE: This equipment has been tested and found to comply with the limits for a Class B digital device, pursuant to Part 15 of the FCC Rules. These limits are designed to provide reasonable protection against harmful interference in a residential installation. This equipment generates, uses and can radiate radio frequency energy and, if not installed and used in accordance with instructions may cause harmful interference to radio or television reception, which can be determined by turning the equipment off and on. The user is encouraged to try to correct the interference by one or more of the following measures:

- ___ Reorient or relocate the receiving antenna.
- ___ Increase the separation between the equipment and receiver.
- ___ Connect the equipment into an outlet on a circuit different from that to which the receiver is connected.
- ___ Consult the dealer or experienced radio/TV technician for help.

Vivitar One Year Warranty

This warranty covers the original consumer purchaser only and is not transferable.

This warranty covers products that fail to function properly UNDER NORMAL USAGE, due to defects in material or workmanship. Your product will be repaired or replaced at no charge for parts or labor for a period of one year.

What is Not Covered by Warranty
Damages or malfunctions not resulting from defects in material or workmanship and damages or malfunctions from other than normal use, including but limited to, repair by unauthorized parties, tampering, modification or accident.

To Obtain Warranty Service and Troubleshooting Information:
Call 1-800-592-9541 in the U.S. or 0-800-917-4831 in the UK or visit our website at www.vivitar.com.

To receive Warranty service along with the name and address of an authorized product service center, the original consumer purchaser must contact us for problem determination and service procedures. Proof of purchase in the form of a bill of sale or receipted invoice, evidencing that the product is within the applicable Warranty period(s), MUST be presented in order to obtain the requested service. It is your responsibility to properly package and send any defective products along with a dated copy of proof of purchase, a written explanation of the problem, and a valid return address to the authorized service center at your expense. Do not include any other items or accessories with the defective product. Any products received by the authorized service center that are not covered by warranty will be returned unrepaid.

Vivitar One Year Warranty (cont.)

NO WARRANTIES, WHETHER EXPRESS OR IMPLIED, INCLUDING, BUT NOT LIMITED TO, ANY IMPLIED WARRANTIES OF MERCHANTABILITY OR FITNESS FOR A PARTICULAR PURPOSE, OTHER THAN THOSE EXPRESSLY DESCRIBED ABOVE SHALL APPLY. DISTRIBUTOR FURTHER DISCLAIMS ALL WARRANTIES AFTER THE EXPRESS WARRANTY PERIOD STATED ABOVE. NO OTHER EXPRESS WARRANTY OR GUARANTY GIVEN BY ANY PERSON, FIRM OR ENTITY WITH RESPECT TO THE PRODUCT SHALL BE BINDING ON DISTRIBUTOR. REPAIR, REPLACEMENT, OR REFUND OF THE ORIGINAL PURCHASE PRICE - AT DISTRIBUTOR'S SOLE DISCRETION - ARE THE EXCLUSIVE REMEDIES OF THE CONSUMER. IN NO EVENT WILL DISTRIBUTOR, ITS MANUFACTURERS, OR SAKAR INT. BE LIABLE FOR ANY INCIDENTAL, DIRECT, INDIRECT, SPECIAL, PUNITIVE OR CONSEQUENTIAL DAMAGES (SUCH AS, BUT NOT LIMITED TO, DAMAGES FOR LOSS OF PROFITS, BUSINESS, SAVINGS, DATA OR RECORDS) CAUSED BY THE USE, MISUSE OR INABILITY TO USE THE PRODUCT. EXCEPT AS STATED HEREIN, NO OTHER WARRANTIES SHALL APPLY. NOTWITHSTANDING THE FOREGOING, CONSUMER'S RECOVERY AGAINST DISTRIBUTOR SHALL NOT EXCEED THE PURCHASE PRICE OF THE PRODUCT SOLD BY DISTRIBUTOR. THIS WARRANTY SHALL NOT EXTEND TO ANYONE OTHER THAN THE ORIGINAL CONSUMER WHO PURCHASED THE PRODUCT AND IS NOT TRANSFERABLE.

This product is manufactured, distributed and sold by SAKAR International, Inc. All other trademarks are the property of the respective owner, who has not sponsored, endorsed or approved this product.

VIVITAR