

Product description

F/ CCT LIGHTING & SPEAKER SYSTEM WITH VOICE CONTROL

part Number

1109037

1108952

1108940

Description

DWG, WIP GRILLE ASSEMBLIES

MODULE, SPEAKER / LED DRIVER

WALL CONTROL, F/ VC(N)110CCT

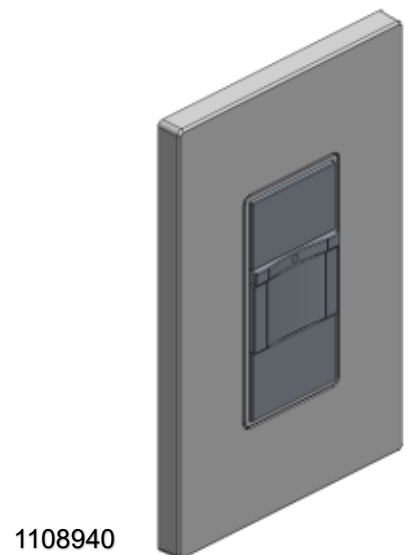
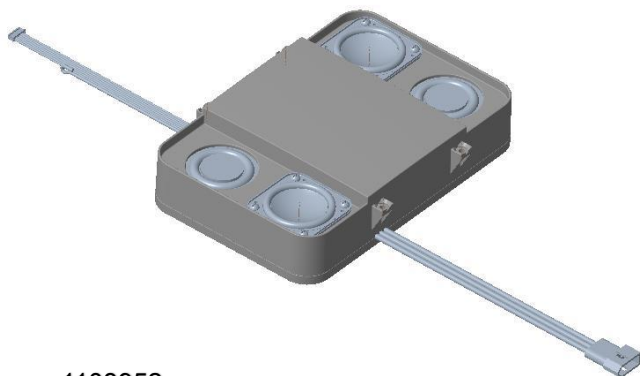
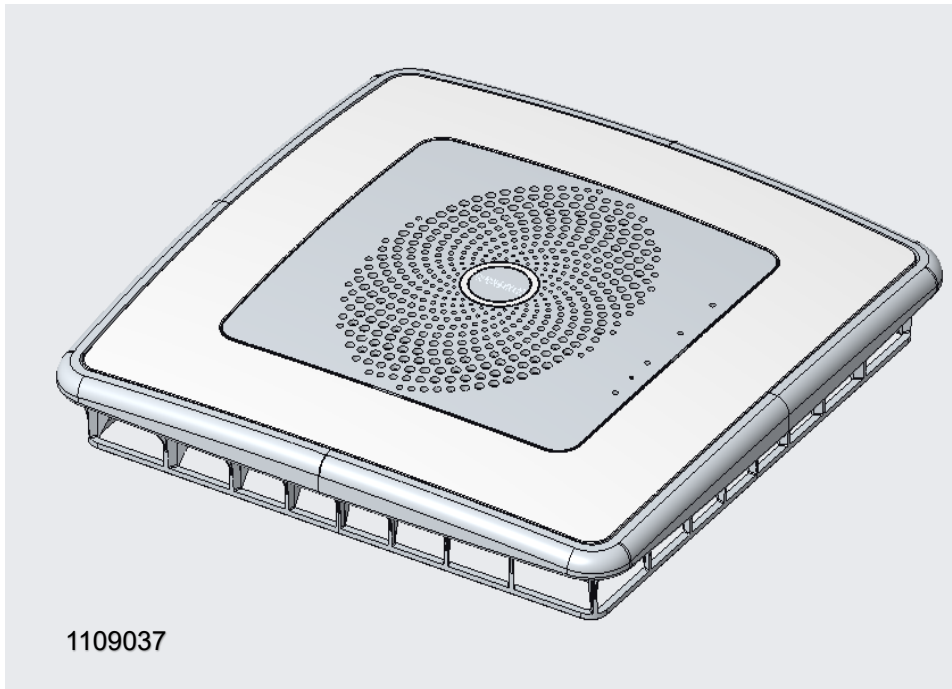

Catalogue

1. SYSTEM OVERVIEW
2. GENERAL SPECIFICATIONS
3. PERFORMANCE SPECIFICATIONS
4. FIRMWARE
5. REGULATORY & CERTIFICATION COMPLIANCE

1.SYSTEM OVERVIEW

The specifications described in this document pertain to all components related to lighting and speaker functionality of the VC110CCT and VCN110CCT, as well as the components and firmware relating to user control of the lighting, speaker, voice, and fan functionalities of the product. All components in the WIP Grille Assembly, and Speaker/Voice/Driver Module shall be compatible with one another. The components involved in this system are:

1.1 WIP Grille Assembly

The WIP grille assembly consists of the main grille plastic, Alexa module with microphones and connecting wires, LED array assembly, lens, and springs which attach the grille to the fan.

1.2 Speaker/Voice/Driver Module

The speaker/voice/driver module mounts to grille assembly, and provides five (5) functions: receives all line-voltage power, receives RF transmissions from the wall control, receives Bluetooth transmissions from a connected device, powers the LED array assembly as needed, routes power to the fan motor via relay.

1.3 Wall Control

The wall control provides primary user input to the system via RF communication with the communication module. The wall control has six (6) switches behind five (4) buttons, is powered by two (2) AAA batteries, mounts to a standard electrical box, and uses a standard rectangular face for use with commonly available cover plates.

1.4 Boundary Diagram

A basic representation of the system, components, and interactions is shown below:

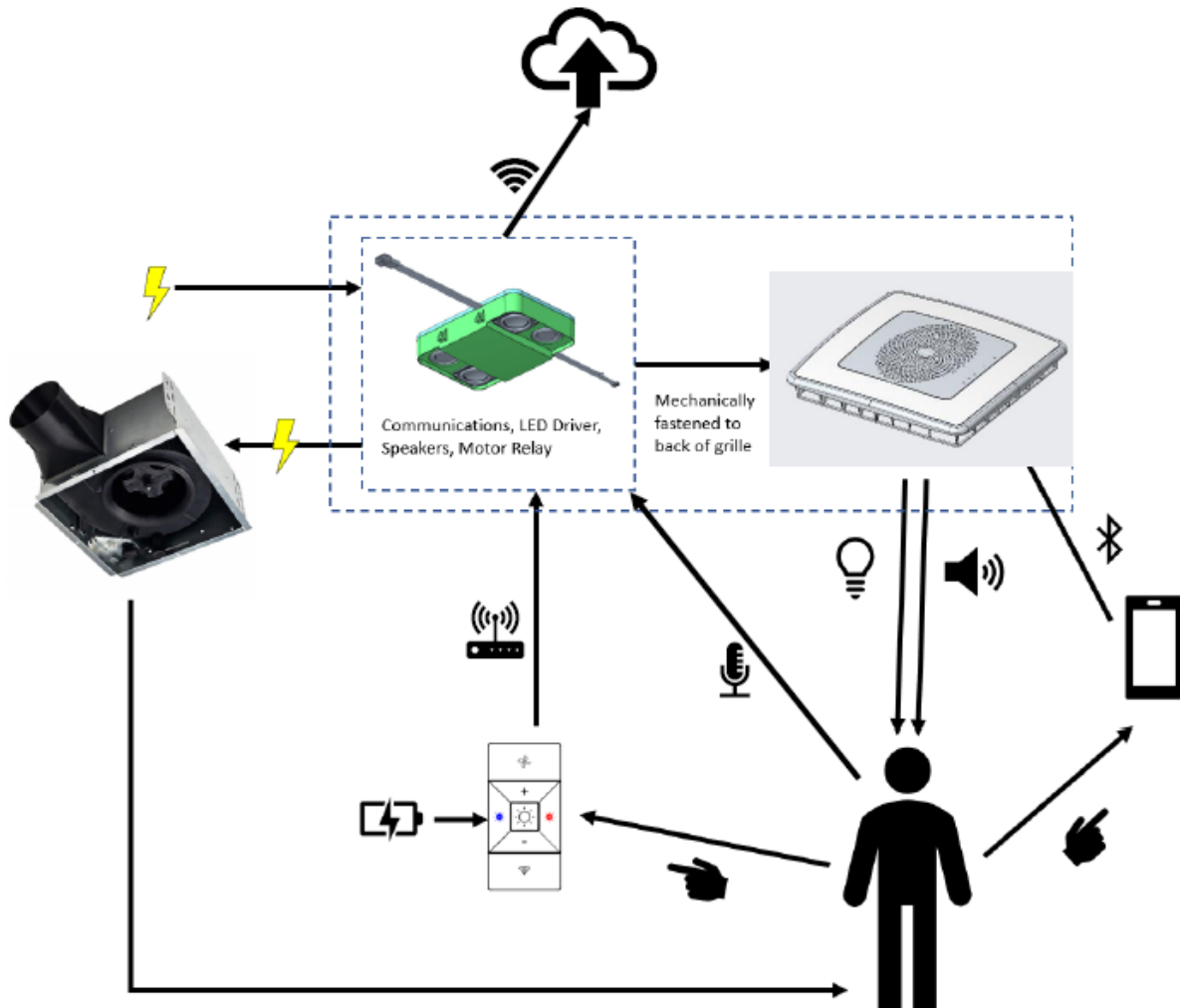

Figure 1: System Boundary Diagram

2. GENERAL SPECIFICATIONS

Application is a driver & LED luminaire with CCT lighting capability, as well as Bluetooth speaker functionality, and voice control functionality for mounting to a residential exhaust fan.

2.1 Controls

Primary control of the system is provided via a battery powered RF remote (wall control). Additional control options are through voice commands via Amazon Alexa or Google Assistant, and a dedicated smartphone app 'VoiceControl' for Android and iOS.

2.2 Life Expectancy

The system is expected to meet all performance specifications with a mean time between failures (MTBF) of 10 years of normal use.

2.3 Operating Environmental Conditions

The system shall meet all performance specifications throughout the full range of operating environmental conditions:

2.3.1 Operating Ambient Temperature Range

0 – 35 °C

2.3.2 Operating Relative Humidity

0 – 95 %RH

2.4 Storage Environmental Conditions

The system shall not be damaged due to long-term storage anywhere within the specified range of storage environmental conditions:

2.4.1 Storage Ambient Temperature Range

-30 - +80 °C

2.4.2 Storage Relative Humidity

0 – 95 %RH

2.5 Electrical Conditions

Unless otherwise specified, validation shall be conducted under nominal input conditions. The product is expected to function, possibly at reduced performance levels, throughout the specified ranges. No product damage or loss of function (temporary or permanent) shall occur within the specified ranges.

2.5.1 Voltage, Normal Operating

Nominal: 120 VAC

Range: 104 – 132 VAC

2.5.2 Voltage, Under & Over

The system must not be damaged or suffer any permanent loss of function due to a supply voltage of < 104 VAC, or 132 – 140 VAC.

2.5.3 Frequency, Normal Operating

Nominal: 60 Hz

Range: 58 – 62 Hz

3. PERFORMANCE SPECIFICATIONS

3.1 General Performance

3.1.1 Dimming

Shall be capable of dimming to ten (10) discrete levels of apparent lumen output, equally distributed from 10% (or lower) to 100% apparent lumen output.

3.1.2 Flicker

Percent flicker: ≤ 30%

Short-Term Perceptibility (Pst) and Stroboscopic Visibility Measurement (SVM) shall be measured and reported per the Energy Star Requirements for Luminaires V2.1.

3.1.3 Audible Noise

≤ 24 dBA at 20% and 100% light output, as measured per the Energy Star Requirements for Luminaires V2.1.

3.1.4 Audio streaming via the internet (Spotify, Pandora, Amazon Music, etc.)

3.1.5 Microphone integration per Tuya requirements for Amazon and Google. \

3.1.6 Ability to access all features via built-in microphones and 3rd party devices

3.1.7 Wall control will include microphone muting, device setup/pairing, and Alexa "Action" button as features

3.2 Electrical Performance

3.2.1 Power Consumption: ≤ 28 W in all modes and dimming levels

3.2.2 Operating Frequency: ≥ 120 Hz

3.2.3 Start Time: ≤ 500 ms

3.2.4 Transient Protection (Driver Class A): Applicable

3.2.5 EMI – Class B for power supplies/driver: Applicable

3.2.6 LED Temperature: Must not exceed component manufacturer's rating in worst-case operating conditions (max ambient temp, no fan operation)

3.2.7 Critical Component Temperature: Must not exceed component manufacturer's rating in worst-case operating conditions (max ambient temp, no fan operation)

3.2.8 Driver Case Temperature: ≤ 100 °C

3.2.9 Input Voltage: 104 – 132. No damage to occur when voltage is less than 104V, or between 132V and 140V

3.3 Wireless Range

3.3.1 Wall Control: > 20 Feet

3.3.2 BT Connection: > 20 ft

3.3.3 Wifi Connection: > 20 ft

3.4 Photometric Performance

3.4.1 Luminous Flux

3000K: ≥ 910 lumens

3500K: ≥ 930 lumens

4000K: ≥ 950 lumens

5000K: ≥ 980 lumens

3.4.2 Luminous Efficacy (initial)

3000K: ≥ 62 lm/W

3500K: ≥ 62 lm/W

4000K: ≥ 66 lm/W

5000K: ≥ 67 lm/W

3.4.3 Correlated Color Temperature (CCT)

Adjustable from 3000K to 5000K

3.4.4 Color Rendering Index (CRI)

All CCT levels: Ra ≥ 90, R9 > 0

3.5 Lumen Maintenance and Rated Life

3.5.1 Lumen Maintenance

TM-21 projection to L95 at max ambient temperature: ≥ 25,000 hours

3.5.2 6000 Hour Survival Rate

≥ 90 %

3.5.3 Rated Life

≥ 25,000 hours until failure to function (loss of light output)

3.6 Audio Performance

3.6.1 Speaker Power

System power rated 10W max (2 speakers rated for a maximum of 5W each)

3.6.2 Individual Speaker Frequency Response

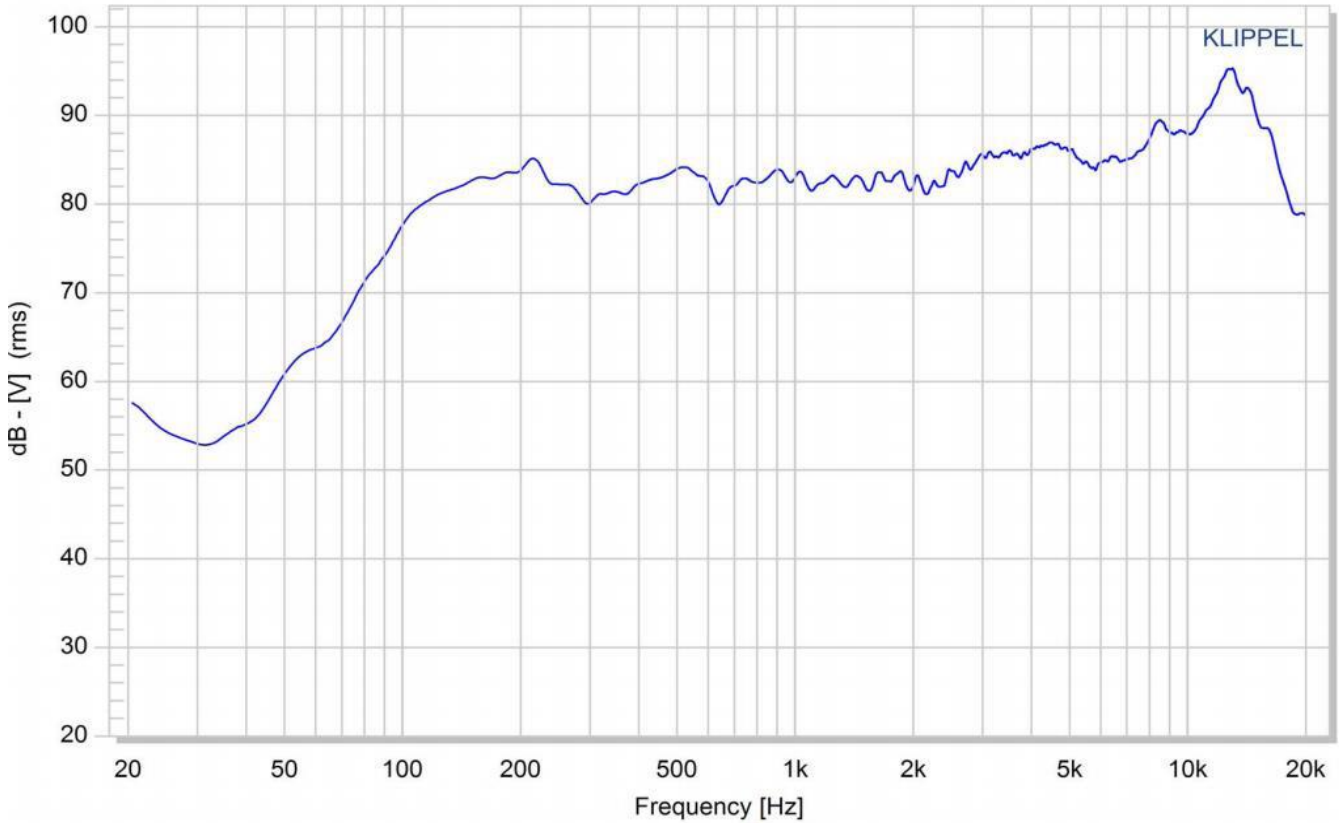

Figure 2: Individual Speaker Frequency Response

3.6.3 System Frequency Response

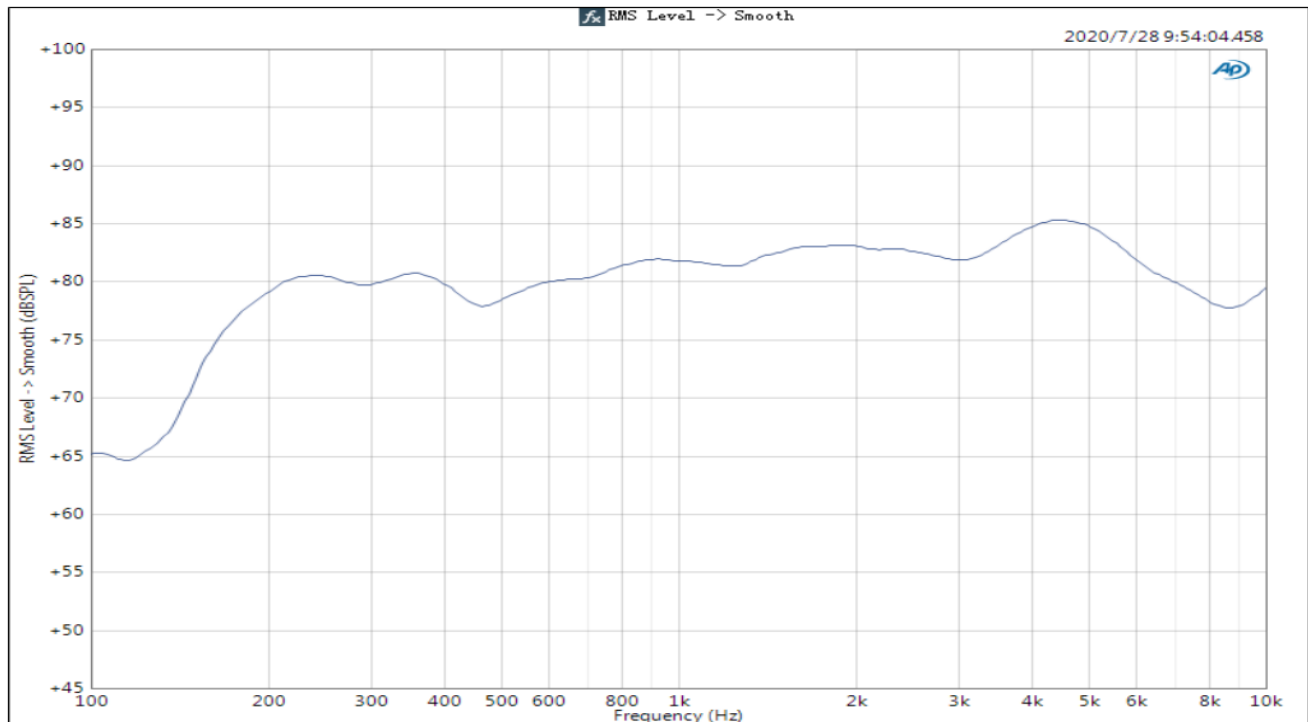

Figure 3: System Frequency Response

3.7 Controls

3.7.1 Wall Control

The system's primary control will come via a radio-frequency (RF) transmitter, capable of being mounted to a standard electrical box and compatible with standard rectangular-opening cover plates per ANSI/NEMA WD-6-2016.

3.7.1.1 Supply Voltage

Power for the wall control is supplied by 2 AAA batteries in series, providing a supply voltage of 1.8 to 3.6V. The wall control shall function as intended throughout this supply voltage range.

3.7.1.2 Battery Life

The RF wall control's power usage shall provide a minimum 75 hours of continuous signal transmission, when powered by 2 AAA batteries beginning at their nominal voltage of 1.5V each.

3.7.1.3 Battery Compatibility

The wall control is not compatible with higher voltage batteries in the AAA form-factor (e.g. 10440 style), but if such batteries are installed the wall control shall fail safely.

3.7.1.4 Transmission Range

When installed in an electrical box with the supplied cover plate, the wall control shall be capable of transmitting a usable signal over an unobstructed distance of at least 20 feet.

3.7.1.5 Switch Life

Switches shall be capable of completing a minimum of 250,000 cycles while energized without failure.

3.7.2 Wifi Control

3.7.2.1 Wifi Module

The Wifi module used shall be Tuya AVS Smart Audio Module VWRK4

3.7.2.2 Transmission Range

With the grille installed as intended in use, the system shall be capable of receiving a signal from a minimum unobstructed distance of 100 feet.

4. FIRMWARE

4.1 Lighting Modes

4.1.1 White Light

The unit is illuminated by white LED array.

4.1.2 CCT

This unit offers a range of CCT levels with infinite adjustability via the smartphone app and wall control. Voice control can change CCT between 4 preset values (3000K, 3500K, 4000K, and 5000K).

4.1.3 Off

No LEDs are illuminated.

4.2 Dimming

The unit shall be capable of dimming in any lighting mode.

4.2.1 Levels

There shall be ten distinct selectable dimming levels between 10% and 100% light output. Dimming levels shall provide a linear change in the perceived light output. This is to be achieved using a logarithmic control profile.

4.2.2 Variables

The dimming levels at any CCT setting shall be independent variables, not carrying over between temperatures i.e. adjusting the dimming level in 5000K mode will not affect the dimming level in the other modes, and vice versa.

4.2.3 Retention

The dimming level and CCT variables shall be stored and retained, such that when the unit is changed to the Off mode, then back to an illuminated mode, it illuminates at the previously used dimming and CCT level.

4.2.4 Upgrades

Firmware shall be upgraded via cloud OTA (minimum) or wireless connection between app and fan. Hardware and firmware shall be designed to ensure that a failed firmware update will not result in a “bricked” device.

4.3 Button Actions

4.3.1 Press

For a momentary RF transmission from 25 to 1200 ms, the corresponding action shall be executed at the end of the transmission (release of the button). See Figure 9.

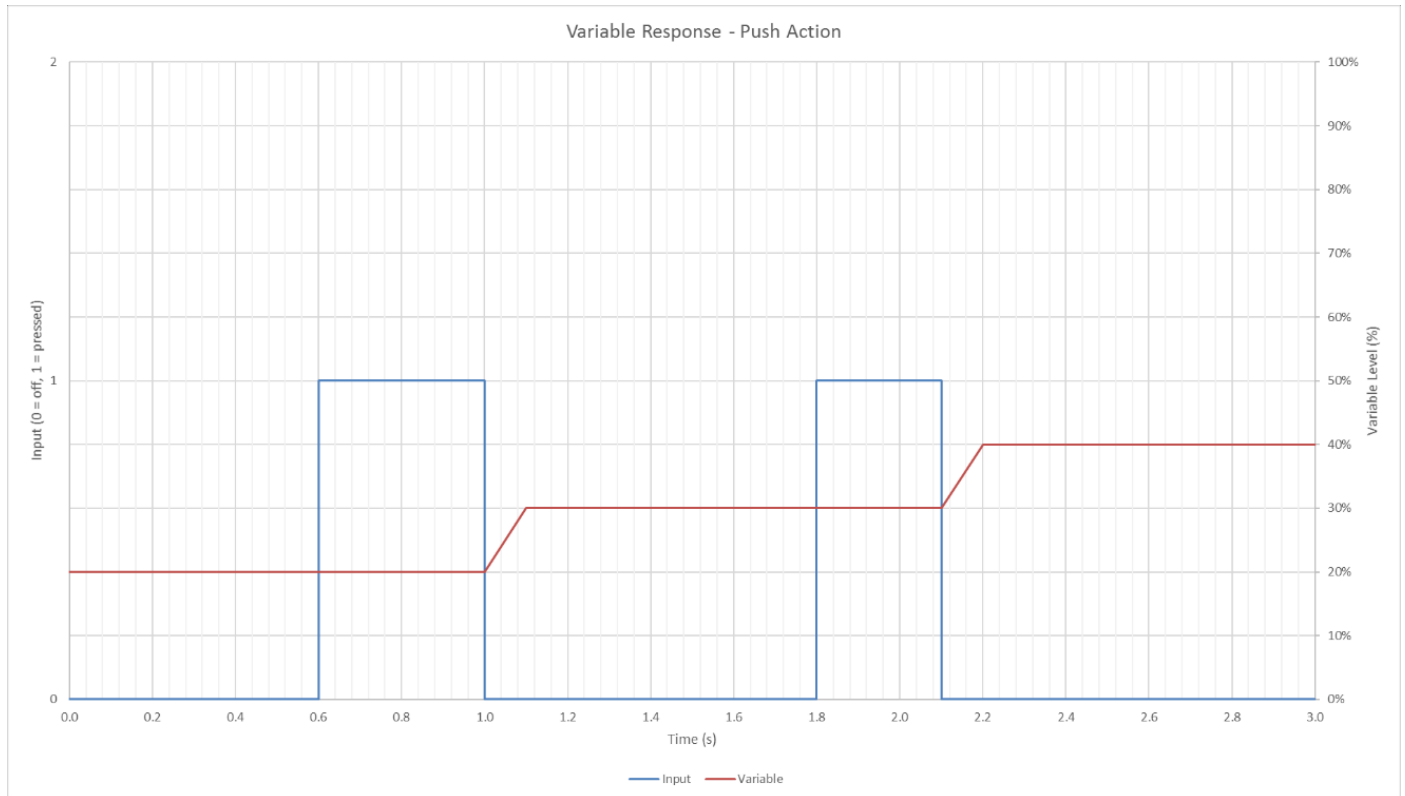

Figure 9: Button Press Action

4.3.2 Press & Hold

For a transmission lasting longer than 1200 ms, the corresponding action shall be executed immediately. Press & hold actions that are adjusting a multi-level variable, such as increasing or decreasing dimming levels, shall be executed continuously until either the transmission is ended or the end of the adjustment range is reached, whichever comes first. See Figure 10.

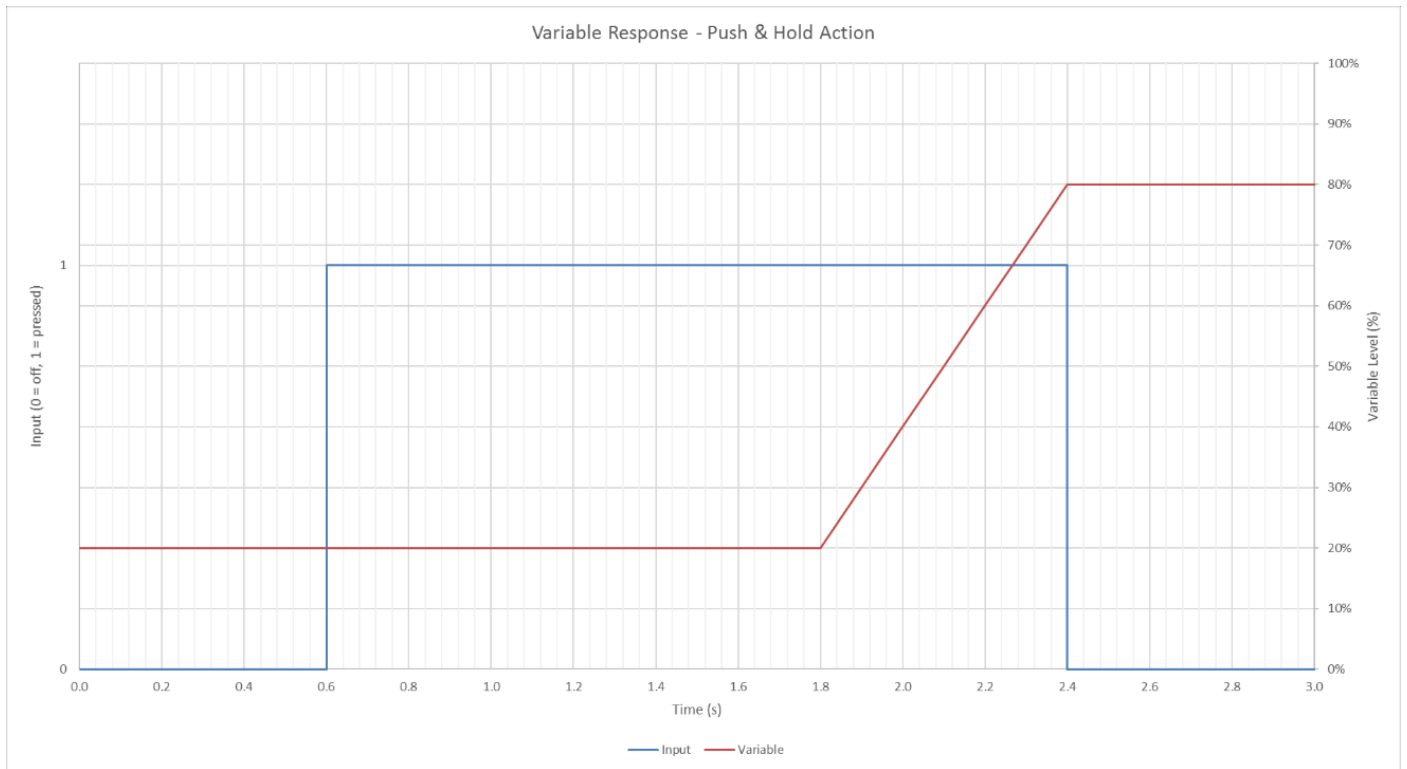

Figure 10: Button Press & Hold Action

4.4 Responses to Button Actions

4.4.1 Transitions

Transitions between variable levels (dimming levels, CCT levels) shall be smooth, and not an abrupt step. Note the ramped change in variable level depicted in Figure 9.

4.4.2 Responses to Inputs

Table 1: Button Responses

Switch #	User Input			Action		
	Button	Action*	Prior State	Result	White Brightness	CCT Color
1	White Light	Press	OFF	Mode: White Light Color: White Brightness: Last used white brightness	N/A	N/A
	White Light	Hold	OFF	Mode: White Light & Activate CCT color adjust buttons 2 & 3 Color: White Brightness: Last used white brightness	N/A	N/A
	White Light	Press	White Light - ON	Mode: Off	Store	N/A
2	Dim "-"	Press	OFF	OFF	N/A	N/A
	Dim "-"	Hold	OFF	OFF	N/A	N/A
	Dim "-"	Press	White Light - ON	Mode: White Light Color: White Brightness: Decrease white brightness by (1) level	Store	N/A
	Dim "-"	Hold	White Light - ON	Mode: White Light Color: White Brightness: Decrease white brightness continually until release	Store	N/A
	Dim "-"	Press	White Light - ON Button 1 - HELD	Mode: White Light Color: Decrease CCT temperature by 1 level	N/A	Store
	Dim "-"	Hold	White Light - ON Button 1 - HELD	Mode: White Light Color: Decrease CCT color continually until release	N/A	Store
3	Dim "+"	Press	OFF	OFF	N/A	N/A
	Dim "+"	Hold	OFF	OFF	N/A	N/A
	Dim "+"	Press	White Light - ON	Mode: White Light Color: White Brightness: Increase white brightness by (1) level	Store	N/A
	Dim "+"	Hold	White Light - ON	Mode: White Light Color: White Brightness: Increase white brightness continually until release	Store	N/A
	Dim "+"	Press	White Light - ON Button 1 - HELD	Mode: White Light Color: Increase CCT temperature by 1 level	N/A	Store
	Dim "+"	Hold	White Light - ON Button 1 - HELD	Mode: White Light Color: Increase CCT color continually until release	N/A	Store
4	Muting/ Wall Control Pairing	Press	Microphone OFF	Microphone ON	N/A	N/A
	Muting/ Wall Control Pairing	Press	Microphone ON	Microphone OFF	N/A	N/A
	Muting/ Wall Control Pairing	Hold > 5s	UN-PAIRED	PAIRING	PAIR CONTROL	N/A
	Muting/ Wall Control Pairing	Hold > 10s	PAIRED	UN-PAIR	UN-PAIR CONTROL	N/A
5	No Function	-	-	-	-	-
6	Action Button/ WiFi BT Pairing	Press	-	Attenuate or pause the activity and put the device into active Listening mode. When an Alert is playing, a single press should stop the alert.	N/A	N/A
	Action Button/ WiFi BT Pairing	Hold > 5s	WiFi/BT unpaired	WiFi/BT pairing	N/A	N/A
	Action Button/ WiFi BT Pairing	Hold > 5s	WiFi/BT paired	WiFi/BT unpairing	N/A	N/A
7	Fan	Press	OFF	Toggle Fan On No change to lighting	N/A	N/A
	Fan	Hold	OFF	Toggle Fan On No change to lighting	N/A	N/A
	Fan	Press	ON	Toggle Fan Off No change to lighting	N/A	N/A
	Fan	Hold	ON	Toggle Fan Off No change to lighting	N/A	N/A

4.5 Control Pairing

4.5.1 Pairing Window

The system shall accept new control pairings, including overwriting an existing control pairing, only during the first 3 minutes after powering the system. This window must be capable of being initiated both by switching the master power source to the driver, as well as by disconnecting and reconnecting the control module from an already powered driver.

4.5.2 Pairing

Pairing of the wall control to the communication module shall be achieved by executing a special press & hold action, as defined in Table 1.

4.5.3 Un-pairing

Un-pairing of the wall control to the communication module shall be achieved by executing a special press & hold action, as defined in Table 1.

5. REGULATORY & CERTIFICATION COMPLIANCE

The system and all components shall comply with the following regulations. In any instance of conflict between Broan or regulatory body requirements, the product must comply with the most stringent requirements.

5.1 UL and cUL Listing

The system and all components shall comply with the following UL standards, as well as the CSA equivalents, as well as any supplementary regulations referenced therein:

5.1.1 UL 507 Edition 10

The system and all components shall comply with the end-product requirements for a ceiling-insert fan intended for use over a bathtub or shower.

5.1.2 UL 8750 Edition 2 & UL 1598 Edition 4

The system and all components shall comply with the requirements for a solid-state luminaire for use in damp locations.

5.1.3 UL 514D Edition 2

The wall control shall comply with the requirements for cover plates, allowing it to safely house live wiring.

5.2 FCC and IC

5.2.1 FCC Caution:

This device complies with Part 15 of the FCC Rules. Operation is subject to the following two conditions: (1) this device may not cause harmful interference, and (2) this device must accept any interference received, including interference that may cause undesired operation.

Caution: The user is cautioned that changes or modifications not expressly approved by the party responsible for compliance could void the user's authority to operate the equipment.

Note: This equipment has been tested and found to comply with the limits for a Class B digital device, pursuant to part 15 of the FCC Rules. These limits are designed to provide reasonable protection against harmful interference in a residential installation. This equipment generates uses and can radiate radio frequency energy and, if not installed and used in accordance with the instructions, may cause harmful interference to radio communications. However, there is no guarantee that interference will not occur in a particular installation. If this equipment does cause harmful interference to radio or television reception, which can be determined by turning the equipment off and on, the user is encouraged to try to correct the interference by one or more of the following measures:

- Reorient or relocate the receiving antenna.
- Increase the separation between the equipment and receiver.
- Connect the equipment into an outlet on a circuit different from that to which the receiver is connected.
- Consult the dealer or an experienced radio/TV technician for help.

FCC RF Radiation Exposure Statement:

This equipment complies with FCC radiation exposure limits set forth for an uncontrolled environment. This equipment should be installed and operated with a minimum distance of 20cm between the radiator and any part of your body.

5.2.2 IC Caution:

This device complies with Industry Canada's licence-exempt RSSs. Operation is subject to the following two conditions:

- (1) This device may not cause interference; and
- (2) This device must accept any interference, including interference that may cause undesired operation of the device.

Le présent appareil est conforme aux CNR d'Industrie Canada applicables aux appareils radio exempts de licence. L'exploitation est autorisée aux deux conditions suivantes : (1) l'appareil ne doit pas produire de brouillage, et (2) l'utilisateur de l'appareil doit accepter tout brouillage radioélectrique subi, même si le brouillage est susceptible d'en compromettre le fonctionnement.

This Class [*] digital apparatus complies with Canadian ICES-003.

Cet appareil numérique de la classe [*] est conforme à la norme NMB-003 du Canada.

This equipment complies with IC RSS-102 radiation exposure limits set forth for an uncontrolled environment. This equipment should be installed and operated with a minimum distance of 20cm between the radiator and any part of your body.

Pour se conformer aux exigences de conformité CNR 102 RF exposition, une distance de séparation d'au moins 20 cm doit être maintenue entre l'antenne de cet appareil et toutes les personnes.

5.3 California Proposition 65 (P65)

The system and components shall comply with the requirements of the Safe Drinking Water and Toxic Enforcement Act of 1986 (California Proposition 65).

5.4 Restriction of Hazardous Substances (RoHS)

The system and components shall not exceed the hazardous substance concentrations set forth in the European Union's (EU) Restriction of the Use of Certain Hazardous Substances (RoHS) Directive, 2003.

5.5 Alexa AVS Certification

This system shall meet all Amazon requirements to work with Alexa.

5.6 Spotify Certification

Pending eSDK registration, this system will be able to integrate with Spotify.