

EN Remove battery cover

1

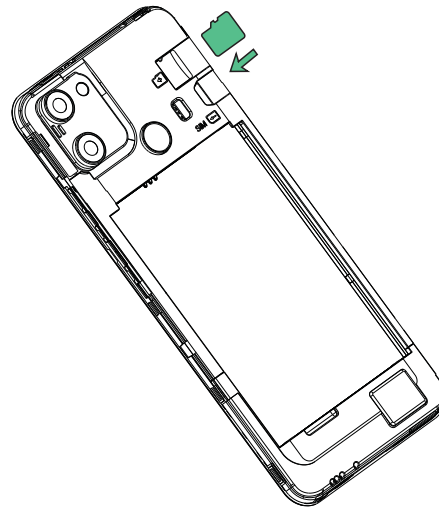

EN Insert memory card

2

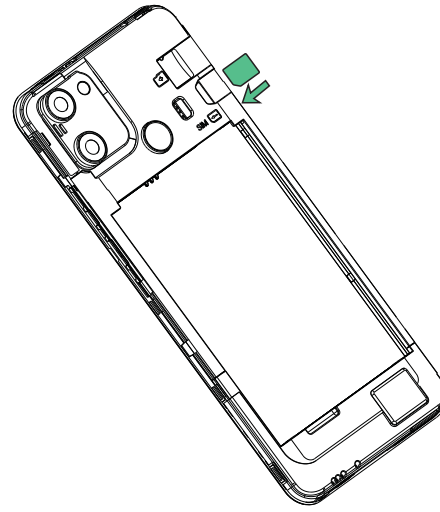

EN Insert SIM card(s)

3

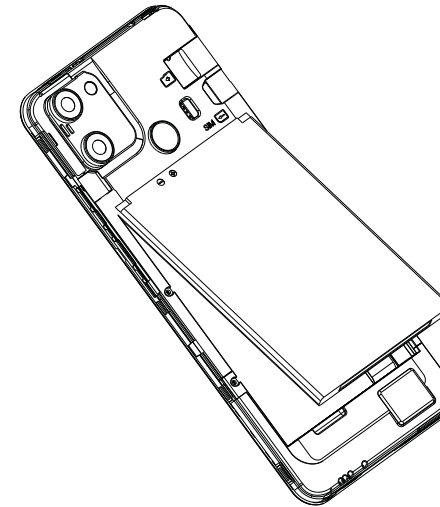

EN Insert battery

4

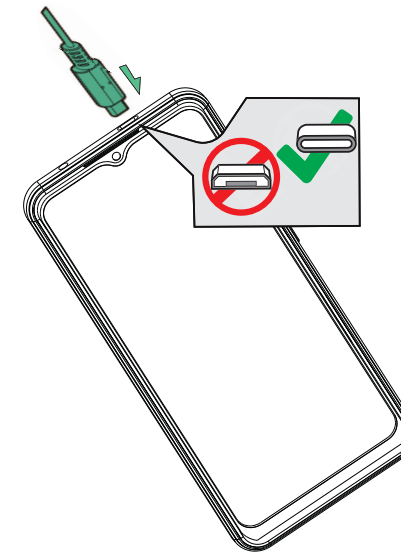

EN Insert USB cable and charge for 3 hours

5



PRODUCT HEX-VISION IMAGE

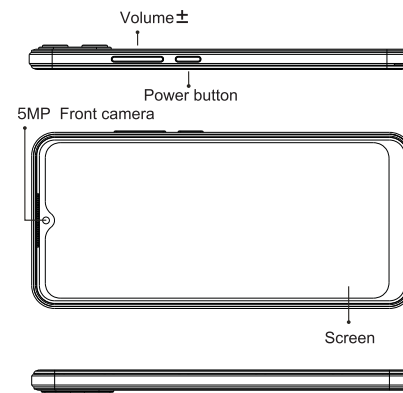

VOLUME BUTTON: Short press to adjust the volume or to mute incoming calls.

6

PRODUCT HEX-VISION IMAGE

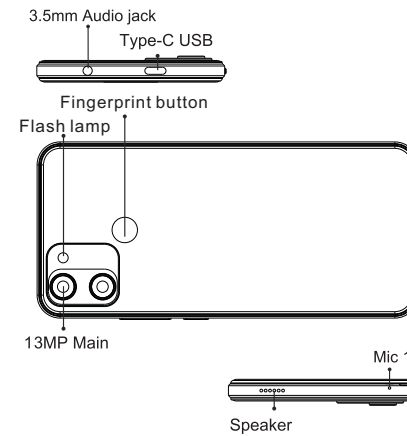

7

SPECIFICATIONS

BASIC INFORMATION

Model HD65
 Operating System Powered by Android™ 13
 CPU 4xA53 2.0GHz GPU IMG GE8300@660
 RAM 4GB
 ROM 64GB
 Battery 4000mAh

Display

Screen Size 6.517 inch HD+
 Resolution 1600*720 Pixels
 Touch Capacitive multi-touch

Cameras

Front Camera 5MP Camera
 Rear Camera 13MP Camera

Connection(I/O)

Band GSM: 850/900/1800/1900
 WCDMA: B2/B4/B5
 LTE: B2/B4/B5/B12/B13/B25/B26/B41/B66/B71
 SIM/TF card 1 Micro SIM Card and 1 TF Card
 WiFi IEEE802.11 a/b/g/n/ac
 Bluetooth Bluetooth 5.0
 GNSS GPS
 FM YES
 Earphone Port 3.5mm
 USB Port Type-C USB

Other Features

Video File Format 3GP/MPEG4, etc
 Audio File Format WAV/MP3/AAC/AMR/MIDI/APE/WMA, etc Card
 Extend Support TF card up to 256 GB
 Language Support Multi-language
 Sensor G-Sensor, Gravity sensor, Compass.

In the box

- 1*Tablet
- 1*Type-C Cable
- 1*Power Adapter
- 1*Quick Start Guide

8

Safety Statement

Pour un fonctionnement porté sur le corps, ce modèle de téléphone a été testé et répond aux directives d'exposition RF FCC/ISED lorsqu'il est utilisé avec un accessoire conçu pour ce produit ou lorsqu'il est utilisé avec un accessoire qui ne contient pas de métal et qui positionne le combiné à au moins 10 mm du corps. Le non-respect des restrictions ci-dessus peut entraîner une violation des directives d'exposition aux RF.

For body-worn operation, this device has been tested and meets the FCC/ISED RF exposure guidelines when used with a leather case. The users must use this leather case. Use of other leather case may not ensure compliance with FCC/ISED RF exposure guidelines.



BE	BG	CZ	DK	DE	EE	IE	EL
ES	FR	HR	IT	CY	LV	LT	LU
HU	MT	NL	AT	PL	PT	RO	SI
SK	FI	SE	NO	IS	LI	CH	TR

In all EU member states, operation of 5150-5250 MHz is restricted to indoor use only.

Made in China



FCC Warning

15.19 Labeling requirements.

This device complies with part 15 of the FCC Rules. Operation is subject to the following two conditions: (1) This device may not cause harmful interference, and (2) this device must accept any interference received, including interference that may cause undesired operation.

15.21 Information to user.

Any Changes or modifications not expressly approved by the party responsible for compliance could void the user's authority to operate the equipment.

15.105 Information to the user.

Note: This equipment has been tested and

found to comply with the limits for a Class B digital device, pursuant to part 15 of the FCC Rules. These limits are designed to provide reasonable protection against harmful interference in a residential installation. This equipment generates uses and can radiate radio frequency energy and, if not installed and used in accordance with the instructions, may cause harmful interference to radio communications. However, there is no guarantee that interference will not occur in a particular installation. If this equipment does cause harmful interference to radio or television reception, which can be determined by turning the equipment off and on, the user is encouraged to try to correct the interference by one or more of the following measures:

- Reorient or relocate the receiving antenna.
- Increase the separation between the equipment and receiver.
- Connect the equipment into an outlet on a circuit different from that to which the receiver is connected.
- Consult the dealer or an experienced radio/TV technician for help.

Absorption Rate (SAR) information:

This device meets the government's requirements for exposure to radio waves. The guidelines are based on standards that were developed by independent scientific organizations through periodic and thorough evaluation of scientific studies. The standards include a substantial safety margin designed to assure the safety of all persons regardless of age

or health.

FCC RF Exposure Information and Statement

The SAR limit of USA (FCC) is 1.6 W/kg averaged over one gram of tissue. This device was tested for typical body-worn operations with the back of the device kept 0mm from the body. To maintain compliance with FCC RF exposure requirements, use accessories that maintain a appropriate separation distance between the user's body and the back of the device. The use of belt clips, holsters and similar accessories should not contain metallic components in its assembly. The use of accessories that do not satisfy these requirements may not comply with FCC RF exposure requirements, and should be avoided.

Use only the supplied or an approved antenna.

ANSI C63.19:2011 HAC RF Categories

The ANSI Standard presents performance requirements for acceptable interoperability of hearing with wireless communications devices. When these parameters are met, a hearing aid operates acceptably in close proximity to a wireless communications device.

WD RF audio Interference level categories in logarithmic units

Emission categories	<960MHz Limits for E-field emissions	>960MHz Limits for E-field emissions
M1	50 to 55 dB (V/m)	40 to 45 dB (V/m)
M2	45 to 50 dB (V/m)	35 to 40 dB (V/m)
M3	40 to 45 dB (V/m)	30 to 35 dB (V/m)
M4	< 40 dB (V/m)	< 30 dB (V/m)

HAC Rate Category: M4

ANSI C63.19:2011 HAC T-coil Categories

Category	Telephone parameters WD signal quality [(signal + noise) – to – noise ratio in decibels]
Category T1	0 dB to 10 dB
Category T2	10 dB to 20 dB
Category T3	20 dB to 30 dB
Category T4	> 30 dB

HAC Rate Category: T3

FCC Hearing Aid Compatibility (HAC) Regulations for Wireless Devices

The U.S. Federal Communications Commission (FCC) has established requirements for digital wireless mobile devices to be compatible with hearing aids and other assistive hearing devices. When individuals employing some assistive hearing devices (hearing aids and cochlear implants) use wireless mobile devices, they may detect a buzzing, humming, or whining noise. Some hearing devices are more immune than others to this interference noise, and mobile devices also vary in the amount of interference they generate.

The wireless telephone industry has developed a rating system for wireless mobile devices to assist hearing device users find mobile devices that may be compatible with their hearing devices. Not all mobile devices have been rated. Mobile devices that are rated have the rating on their box or a label located on the box. The ratings are not guarantees. Results will vary depending on the user's hearing device and hearing loss. If your hearing device happens to be vulnerable to interference, you may not be able to use a rated mobile device successfully. Trying out the mobile device with your hearing device is the best way to evaluate it for your personal needs.