



RFD900ux2 Radio Modem

User Manual

902-928MHz frequency band



General Cautions

During operation there must be a separation distance of 20cm between all persons and the antenna. Ensure that all used RF connectors are secure and properly terminated.

When used in the US - FCC Caution

Caution: The user is cautioned that changes or modifications not expressly approved by the party responsible for compliance could void the user's authority to operate the equipment.

Note: This equipment has been tested and found to comply with the limits for a Class B digital device, pursuant to part 15 of the FCC Rules. These limits are designed to provide reasonable protection against harmful interference in a residential installation. This equipment generates, uses and can radiate radio frequency energy and, if not installed and used in accordance with the instructions, may cause harmful interference to radio communications. However, there is no guarantee that interference will not occur in a particular installation. If this equipment does cause harmful interference to radio or television reception, which can be determined by turning

the equipment off and on, the user is encouraged to try to correct the interference by one or more of the following measures:

- Reorient or relocate the receiving antenna.
- Increase the separation between the equipment and receiver.
- Connect the equipment into an outlet on a circuit different from that to which the receiver is connected.
- Consult the dealer or an experienced radio/TV technician for help.

This equipment complies with FCC's RF radiation exposure limits set forth for an uncontrolled environment. The antenna(s) used for this transmitter must be installed and operated to provide a separation distance of at least 20 cm from all persons and must not be collocated or operating in conjunction with any other antenna or transmitter. Installers must ensure that 20cm separation distance will be maintained between the device (excluding its handset) and users.

When used in Canada - ISED Caution

This device complies with RSS 210 of the Industry Canada Rules. Operation is subject to the following two conditions:

(1) this device may not cause interference, and (2) this device must accept any interference, including interference that may cause undesired operation of the device.

Le présent appareil est conforme aux CNR d'Industrie Canada applicables aux appareils radio exempts de licence. L'exploitation est autorisée aux deux conditions suivantes :

(1) l'appareil ne doit pas produire de brouillage, et (2) l'utilisateur de l'appareil doit accepter tout brouillage radioélectrique subi, même si le brouillage est susceptible d'en compromettre le fonctionnement.

This equipment complies with Canada radiation exposure limits set forth for uncontrolled environments. This equipment should be installed and operated with a minimum distance of 20cm (may be adjusted according to actual calculation result) between the radiator and your body.

This transmitter must not be co-located or operating in conjunction with any other antenna or transmitter.

Déclaration d'IC sur l'exposition aux radiations:

Cet équipement est conforme aux limites d'exposition aux radiations définies par le Canada pour des environnements non contrôlés. Cet équipement doit être installé et utilisé à une distance minimum de 20 cm entre l'antenne et votre corps.

Cet émetteur ne doit pas être installé au même endroit ni utilisé avec une autre antenne ou un autre émetteur

Acceptable Antennas

This device has been designed to operate with the antenna(s) listed below and having a maximum gain of 3 dBi.

Antennas not included in this list or having a gain greater than 3 dBi are strictly prohibited for use with this device.

The required antenna impedance is 50 ohms.

Acceptable antenna – 3dBi RFD whip.

Table of contents

1	Key Features.....	5
2	Specifications	6
3	OEM Labelling	7
4	Pin signals and layout.....	8
5	Physical dimensions	9
6	Software/GCS Support	10
7	Diversity	11
7.1	Spatial diversity	11
7.2	Polarisation diversity.....	11
8	Network options	12
8.1	Simple pair (P2P).....	12
8.2	Asynchronous non-hopping mesh	12
8.3	Multipoint synchronised mesh	13
9	Useful links	14
10	Revision History.....	14

1 Key Features

Features

- Out of the box RF communications.
- Air data rate speeds of up to 224kbps
- Diversity antenna support
- Weight of 14g
- Outdoor RF line-of-site range of 40km or more depending on antenna configuration

Operational

- Operating voltage: 5V, I/O Voltage (3.3V)
- Temperature range: -40°C to +85°C
- Dimensions of 21mm x 33mm x 10.65mm
- Current consumption:
 - TX mode: ~1A peak at +30dBm,
 - RX mode: 45mA (typical)

Applications

- Telemetry data
- UAV control
- Remote weather station
- House automation
- Long range RC

2 Specifications

Performance	
Supported RF Data Rates	12 to 224 kbps dependent on type and version of firmware
Indoor Range	500m – 1km
Line-Of-Sight Range	40km or more depending on antennas and settings
Transmit Power	0 to 30dBm in 1dBm steps
Receiver Sensitivity	-108dBm @ 10 ⁻⁵ BER 12Kbps
Low Noise Amplifier	>20dB gain

Features	
Serial Data Interface	+3.3V nominal, 3.3V tolerant
Configuration Method	AT Commands, APM Planner, RF Design Modem Tools
Frequency Band	902MHz - 928MHz
Interference Immunity	FHSS (Frequency Hopping Spread Spectrum)
Serial Interface Data Rate	2400 to 1000000 bps dependent on type and version of firmware
Antenna Connection	2 x uFl diversity switched ports
GPIO	1 pin (Digital, PPM capable)
Compliance Standards	FCC Part 15.247, AS/NZS 4268:2012

Networking and Security	
Addressing Options	Network ID: 0 –255
Channels	Up to 51 Frequency Hopping Channels
Supported Network Topologies	Point-to-point and asynchronous mesh ¹ and multipoint synchronous mesh ¹

¹ Only available in separate firmware versions available on the RFD website

Power Requirements	
Supply Voltage	+5V nominal (+5V min, +5.5V Max, +6V ABS Max),
Transmit Current	~900mA peak at max power
Receive Current	~45mA

3 OEM Labelling

For equipment containing the RFD900ux2 where the RFD900ux2 label is not visible the following applies.

Equipment using the RFD900ux2 in the USA must display a label referring to the enclosed module. This label must contain the words "Contains FCC ID: 2ADLE-900UX2".

Equipment using the RFD900ux2 in Canada must display a label referring to the enclosed module. This label must contain the words "Contains IC ID: 24610-900UX2".

4 Pin signals and layout

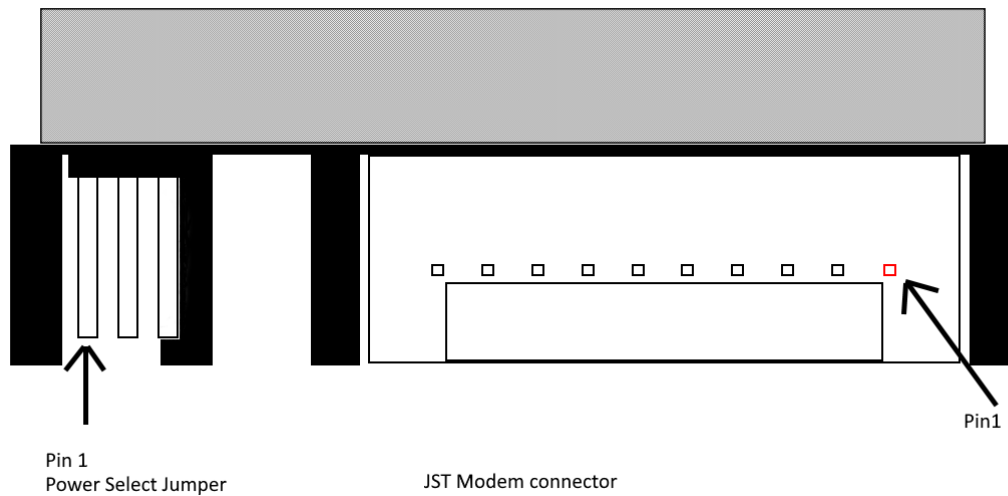

Figure 4-1 Connector diagram rear of ux modem

Pin #	Name	Description	Max Voltage
1	V External	External 5V supply, connected to pin 2 of JST connector.	5V
2	Supply	The supply pin for the modem	5V
3	V Standard	5V supply, connected to pin 5 of JST connector, for supply from a Pixhawk or FTDI	5V

Table 4-1: Pin functions for power jumper

Pin #	Name	Direction	Description	Max Voltage
1	GND	-	Ground	0V
2	V External	Input	External 5V supply	5V
3	GND	-	Ground	0V
4	GPIO1_EXT	I/O	Digital I/O, PPM I/O	3.3V
5	V Standard	INPUT	Pixhawk/FTDI 5V supply	5V
6	RX	Input	UART Data In	3.3V
7	TX	Output	UART Data Out	3.3V
8	RTS	Output	Request to send	3.3V
9	CTS	Input	UART Clear to send	3.3V
10	GND	-	Ground	0V

Table 4-2: Pin ux modem JST connector

Note: A jumper must be fitted between pin 1 and 2 (external supply) or pin 2 and 3 (Pixhawk/FTDI supply) to power the modem.

5 Physical dimensions

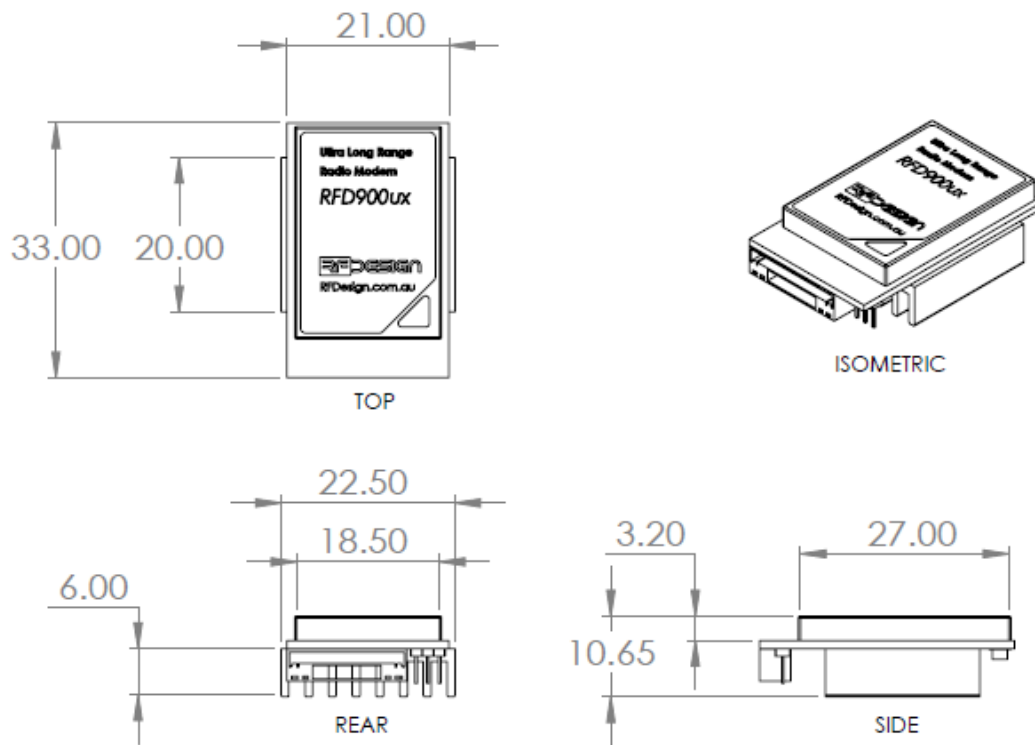

6 Software/GCS Support

The default firmware (see “Useful Links”) is a development of the open source project called “SiK” and was created by Mike Smith. It has been further developed and modified by Andrew Tridgell and RFDesign.

The modems feature a boot loader to facilitate field upgrade of the modem firmware via the serial port. This is most easily performed by using the latest version RFD Modem tools (see “Useful links”)

Parameters such as power levels, air data rates, serial speeds, GPIO pins etc can all be custom set by the user using the AT Command set, the RFD Modem Tools V2 or later and APM Planner.

Default serial port settings are as follows:

- 57600 baud
- No parity
- 8 data bits
- 1 stop bit

The RFD900ux2 Radio Modem has many software features including:

- Frequency Hopping Spread Spectrum
- Transparent Serial Link
- Configuration by AT commands for local radio, RT Commands for remote radio
- User configurable serial data rates and air data rates
- Error correction routines
- 128-bit AES hardware encryption with user settable key
- MAVLink protocol framing (user selectable)
- MAVLink radio status reporting (Local RSSI, Remote RSSI, Local Noise, Remote Noise)
- Automatic antenna diversity switching on a packet basis in real-time
- Automatic duty cycle throttling based on radio temperature to avoid overheating
- PPM (R/C signal) pass through (Control vehicle across radio).
- GPIO pin mirroring

7 Diversity

The RFD900ux2 has two antenna ports and firmware which supports diversity operation of antennas. During the receive sequence the modem will check both antennas and select the antenna with the best receive signal. The antenna selected during receive is then also used for subsequent transmission. In the case of only one antenna connected, it will automatically select the port with the antenna connected. Testing by Silicon Labs has shown that link budgets can be improved up to the order of 8dB by employing a diversity scheme.

7.1 Spatial diversity

Spatial diversity is the case where the antennas are separated by some distance from one another. It is recommended that two antennas connected to the RFD900 modem be separated by at least 25cm, more if possible.

7.2 Polarisation diversity

Polarisation diversity is the case where the antennas are perpendicular to each other. i.e. one vertical, and one horizontal. This is effective in reducing multipath effects which affect one or the other polarisation. This scheme also helps to maintain the link between non-static objects such as aircraft performing acrobatics by increasing the likelihood that one antenna will maintain the same polarisation as an antenna on the other side of the link. Figure 8-1 depicts how two right-angle monopole antennas can be positioned to achieve polarisation diversity.

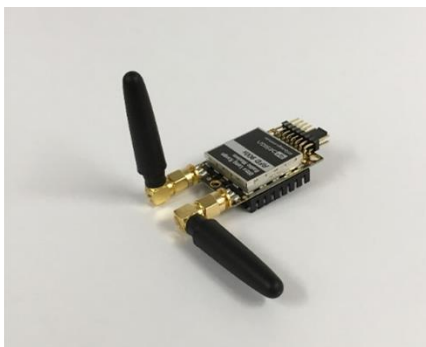

Figure 8-1: Antenna configuration to achieve polarisation diversity

8 Network options

RFD900ux2 support firmware for simple pair (peer to peer), asynchronous mesh network and multipoint network. Available for download from the website (see “Useful Links”).

8.1 Simple pair (P2P)

The out-of-the-box firmware of the RFD900ux2 radio modem is set to work in simple pair mode. If you purchased a bundle, you are only required to connect the antennas and supply to initiate the link. As soon as the pair synchronises, the on-board LED will become solid green.

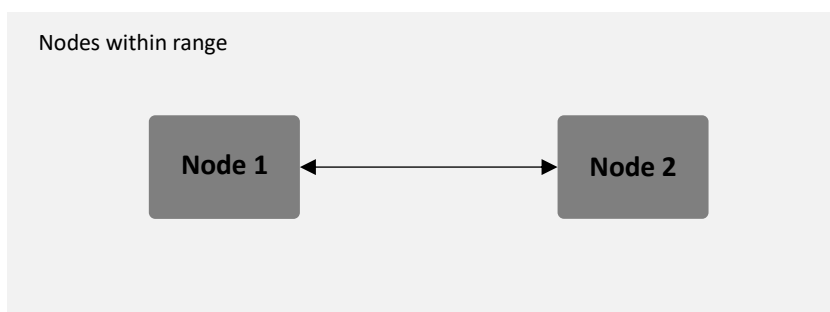

Figure 8-1 Peer to peer modem pair network

8.2 Asynchronous non-hopping mesh

The asynchronous non-forwarding mesh firmware offers a straight forward communication option that allows the user to quickly transmit and receive data across a great distance between two or more nodes. Figure 9-2 depicts this communication topology. If all the nodes are within range and have compatible parameters, communication between them will succeed.

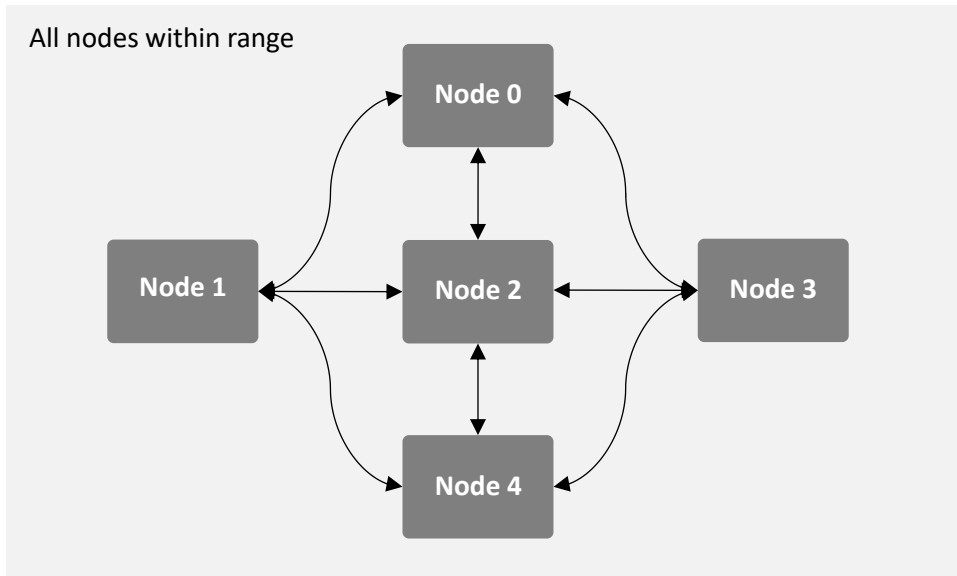

Figure 8-2 Asynchronous mesh topology

It is also possible to establish forwarding between nodes in the network. (See the asynchronous firmware datasheet for details)

8.3 Multipoint synchronised mesh

The network requires that one of the devices assumes a *base* role to control the timeslot distribution of the surrounding radios. If one of the nodes is out of the base's range, communication is still possible if the parameter *SyncAny* is properly set.

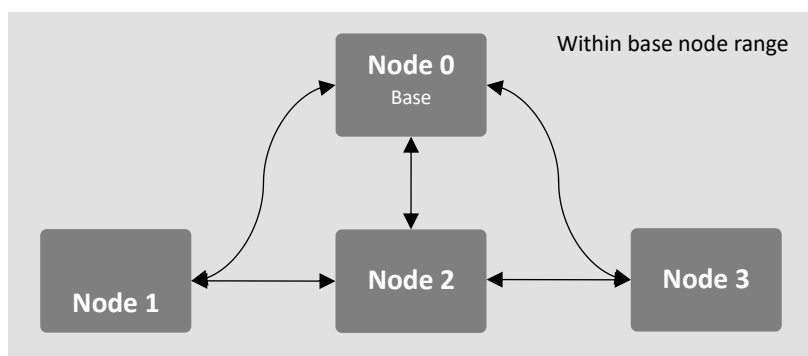

Figure 8-3 Multipoint mesh topology

9 Useful links

RFD900ux2 Firmware

<http://rfdesign.com.au/firmware/>

RFD SiK firmware is default

RFD Asynchronous firmware

RFD Multipoint firmware

RFD900ux2 Flash Programmer

<http://rfdesign.com.au/downloads/>

FTDI Cable documentation

http://www.ftdichip.com/Support/Documents/DataSheets/Cables/DS_TTL-232R_CABLES.pdf

10 Revision History

Version	Date	Changes
1.0	22/09/17	Release document
1.1	22/05/18	Updated to correct typos, mistakes, and changes in new versions
2.0	1/11/18	Updated for compliance
2.1	6/5/22	Updated for the RFD900ux2
2.2	21/6/22	Updated for RFD900ux2 compliance