

**FCC 47 CFR PART 15 SUBPART C
INDUSTRY CANADA RSS-210 ISSUE 8**

CERTIFICATION TEST REPORT

For

Tablet PC

MODEL No.: Magnus10A

FCC ID: 2ADL6-TC10A

IC: 12656A-TC10A

Trademark: MCTC, MCT Corp.

REPORT NO.: ES141203028E2

ISSUE DATE: January 20, 2015

Prepared for

MITAC COMPUTING TECHNOLOGY CORPORATION

NO.200, WEN HWA 2ND RD., KUEI SAN HSIAN, TAOYUAN333, Taiwan

Prepared by

SHENZHEN EMTEK CO., LTD.

**Bldg 69, Majialong Industry Zone, Nanshan District, Shenzhen,
Guangdong, China
TEL: 86-755-26954280
FAX: 86-755-26954282**

Table of Contents

1 TEST RESULT CERTIFICATION 3

2 EUT TECHNICAL DESCRIPTION 4

3 SUMMARY OF TEST RESULT 6

4 TEST METHODOLOGY 7

 4.1 GENERAL DESCRIPTION OF APPLIED STANDARDS 7

 4.2 MEASUREMENT EQUIPMENT USED 7

 4.3 DESCRIPTION OF TEST MODES 8

5 FACILITIES AND ACCREDITATIONS 9

 5.1 FACILITIES 9

 5.2 LABORATORY ACCREDITATIONS AND LISTINGS 9

6 TEST SYSTEM UNCERTAINTY 10

7 SETUP OF EQUIPMENT UNDER TEST 11

 7.1 RADIO FREQUENCY TEST SETUP 1 11

 7.2 RADIO FREQUENCY TEST SETUP 2 11

 7.3 CONDUCTED EMISSION TEST SETUP 13

 7.4 BLOCK DIAGRAM CONFIGURATION OF TEST SYSTEM 14

 7.5 SUPPORT EQUIPMENT 14

8 FREQUENCY HOPPING SYSTEM REQUIREMENTS 15

 8.1 STANDARD APPLICABLE 15

 8.2 EUT PSEUDORANDOM FREQUENCY HOPPING SEQUENCE 15

 8.3 FREQUENCY HOPPING SYSTEM 16

9 TEST REQUIREMENTS 17

 9.1 20 DB BANDWIDTH 17

 9.2 99% OCCUPIED BANDWIDTH 23

 9.3 CARRIER FREQUENCY SEPARATION 24

 9.4 NUMBER OF HOPPING FREQUENCIES 30

 9.5 AVERAGE TIME OF OCCUPANCY (DWELL TIME) 34

 9.6 MAXIMUM PEAK CONDUCTED OUTPUT POWER 38

 9.7 CONDUCTED SUPRIIOUS EMISSION 44

 9.8 RADIATED SPURIOUS EMISSION 56

 9.9 CONDUCTED EMISSION TEST 70

 9.10 ANTENNA APPLICATION 73

1 TEST RESULT CERTIFICATION

Applicant:	MITAC COMPUTING TECHNOLOGY CORPORATION
Manufacturer:	MITAC COMPUTING TECHNOLOGY CORPORATION
EUT Description:	Tablet PC
Model Number:	Magnus10A (White or Black appearance)
File Number:	ES141203028E2
Date of Test:	December 15, 2014 to December 27, 2014

Measurement Procedure Used:

APPLICABLE STANDARDS		
STANDARD		TEST RESULT
FCC 47 CFR Part 2, Subpart J FCC 47 CFR Part 15, Subpart C	RSS 210 Version 8.0 , Dec 2010, RSS GEN: Issue 4 Nov 2014	PASS

The above equipment was tested by SHENZHEN EMTEK CO., LTD. The test data, data evaluation, test procedures, and equipment configurations shown in this report were made in accordance with the procedures given in ANSI C63.4 (2014) and the energy emitted by the sample EUT tested as described in this report is in compliance with the requirements of FCC Rules Part 2 and Part 15.247

The test results of this report relate only to the tested sample identified in this report

Date of Test : December 15, 2014 to December 27, 2014



Prepared by : _____
Back Huang/Editor



Reviewer : _____
Joe Xia/Supervisor



Approve & Authorized Signer : _____
Lisa Wang/Manager

2 EUT TECHNICAL DESCRIPTION

Characteristics	Description
Device Type:	Portable device
Data Rate	1Mbps/2Mbps/3Mbps
Modulation:	GFSK modulation for 1Mbps π /4-DQPSK modulation for 2Mbps 8DPSK modulation for 3Mbps
Bluetooth Version:	Bluetooth 4.0 for Classic Bluetooth
Operating Frequency Range(s):	2402-2480MHz
Number of Channels:	79 Channels
Transmit Power Max:	3.63dBm
Antenna Type :	Integral Antenna
Antenna Gain:	2dBi ;
Power supply:	<input checked="" type="checkbox"/> DC supply: DC3.7V internal rechargeable lithium battery or DC 5V from USB adapter or DC 5V from PC
	<input checked="" type="checkbox"/> Adapter supply: Model: HNEG050200UX Input: 100-240V~ 50/60Hz, 0.35A MAX Output: DC 5.0V, 2.0A
FCC ID:	2ADL6-TC10A
IC:	12656A-TC10A
Product SW/HW version:	Android 4.4.2 /Magnus10A.20141127.v1.0.0
Radio SW/HW version:	MEDIATEK MT6627N /S.MT82.3
Test SW Version:	EngineerMode:.-3646633-. =
RF power setting in TEST SW:	Max power

Note: for more details, please refer to the User's manual of the EUT.

Modified Information

Version.	Summary	Date of Rev.	Report No.
Ver.1.0	Original Report	2015-01-25	ES141203028E2

3 SUMMARY OF TEST RESULT

FCC Part Clause	IC Part Clause	Test Parameter	Verdict	Remark
15.247(a)(1)	RSS-210.A8.1(a)	20 dB Bandwidth	PASS	
/	RSS-Gen.6.6	99% Occupied Bandwidth	PASS	
15.247(a)(1)	RSS-210.A8.1(b)	Carrier Frequency Separation	PASS	
15.247(a)(1)	RSS-210.A8.1(d)	Number of Hopping Frequencies	PASS	
15.247(a)(1)	RSS-210.A8.1	Average Time of Occupancy (Dwell Time)	PASS	
15.247(b)(1)	RSS-210.A8.4	Maximum Peak Conducted Output Power	PASS	
15.247(c)	RSS-210.A8.5	Conducted Spurious Emissions	PASS	
15.247(d) 15.209	RSS-Gen.6.13 RSS-Gen 8.9 RSS-Gen 8.10	Radiated Spurious Emissions	PASS	
15.207	RSS-Gen 8.8	Conducted Emission	PASS	
15.247(b)	RSS-Gen.8.3	Antenna Application	PASS	Antenna requirement is no need for IC
NOTE1: N/A (Not Applicable)				

4 TEST METHODOLOGY

4.1 GENERAL DESCRIPTION OF APPLIED STANDARDS

According to its specifications, the EUT must comply with the requirements of the following standards:
 FCC 47 CFR Part 2, Subpart J
 FCC 47 CFR Part 15, Subpart C
 DA 00-705
 IC RSS 210 Version 8.0 , Dec 2010
 IC RSS GEN: Issue 4 Nov 2014

4.2 MEASUREMENT EQUIPMENT USED

4.2.1 Conducted Emission Test Equipment

EQUIPMENT TYPE	MFR	MODEL NUMBER	SERIAL NUMBER	LAST CAL.
Test Receiver	Rohde & Schwarz	ESCS30	828985/018	05/17/2014
L.I.S.N.	Schwarzbeck	NNLK8129	8129203	05/17/2014
50Ω Coaxial Switch	Anritsu	MP59B	M20531	N/A
Pulse Limiter	Rohde & Schwarz	ESH3-Z2	100006	05/17/2014
Voltage Probe	Rohde & Schwarz	TK9416	N/A	05/17/2014
I.S.N	Rohde & Schwarz	ENY22	1109.9508.02	05/17/2014

4.2.2 Radiated Emission Test Equipment

EQUIPMENT TYPE	MFR	MODEL NUMBER	SERIAL NUMBER	LAST CAL.
EMI Test Receiver	Rohde & Schwarz	ESU	1302.6005.26	05/17/2014
Pre-Amplifier	HP	8447D	2944A07999	05/17/2014
Bilog Antenna	Schwarzbeck	VULB9163	142	05/17/2014
Loop Antenna	ARA	PLA-1030/B	1029	05/17/2014
Horn Antenna	Schwarzbeck	BBHA 9170	BBHA9170399	05/17/2014
Horn Antenna	Schwarzbeck	BBHA 9120	D143	05/17/2014
Cable	Schwarzbeck	AK9513	ACRX1	05/17/2014
Cable	Rosenberger	N/A	FP2RX2	05/17/2014
Cable	Schwarzbeck	AK9513	CRPX1	05/17/2014
Cable	Schwarzbeck	AK9513	CRRX2	05/17/2014

4.2.3 Radio Frequency Test Equipment

EQUIPMENT TYPE	MFR	MODEL NUMBER	SERIAL NUMBER	LAST CAL.
Spectrum Analyzer	Agilent	E4407B	88156318	05/17/2014
Power meter	Anritsu	ML2495A	0824006	05/17/2014
Power sensor	Anritsu	MA2411B	0738172	05/17/2014
Signal Analyzer	Agilent	N9010A	My53470879	05/17/2014

Remark: Each piece of equipment is scheduled for calibration once a year.

4.3 DESCRIPTION OF TEST MODES

The EUT has been tested under its typical operating condition.

The EUT configuration for testing is installed on RF field strength measurement to meet the Commissions requirement and operating in a manner which intends to maximize its emission characteristics in a continuous normal application.

The Transmitter was operated in the normal operating mode. The TX frequency was fixed which was for the purpose of the measurements.

Test of channel included the lowest and middle and highest frequency to perform the test, then record on this report.

Those data rates (1Mbps for Bluetooth v2.0 /v2.1/v3.0 BR GFSK modulation; 2Mbps for Bluetooth v2.0/v2.1 /v3.0 EDR $\pi/4$ -DQPSK modulation; 3Mbps for Bluetooth v2.0/v2.1 /v3.0 EDR 8DPSK modulation) were used for all test.

Pre-defined engineering program for regulatory testing used to control the EUT for staying in continuous transmitting and receiving mode is programmed.

Frequency and Channel list for Classic Bluetooth:

Channel	Frequency (MHz)	Channel	Frequency (MHz)	Channel	Frequency (MHz)
0	2402	39	2441
1	2403	40	2442	76	2478
2	2404	41	2443	77	2479
...	78	2480

Note: $f_c = 2402\text{MHz} + (k-1) \times 1\text{MHz}$ $k=1$ to 79

Test Frequency and channel for Classic Bluetooth:

Lowest Frequency		Middle Frequency		Highest Frequency	
Channel	Frequency (MHz)	Channel	Frequency (MHz)	Channel	Frequency (MHz)
0	2402	39	2441	78	2480

5 FACILITIES AND ACCREDITATIONS

5.1 FACILITIES

All measurement facilities used to collect the measurement data are located at

Bldg 69, Majialong Industry Zone District, Nanshan District, Shenzhen, China

The sites are constructed in conformance with the requirements of ANSI C63.7, ANSI C63.4 and CISPR Publication 22.

5.2 LABORATORY ACCREDITATIONS AND LISTINGS

Site Description

- EMC Lab.
- : Accredited by CNAS, 2013.10.29
The certificate is valid until 2016.10.28
The Laboratory has been assessed and proved to be in compliance with CNAS-CL01: 2006(identical to ISO/IEC17025: 2005)
The Certificate Registration Number is L2291
 - : Accredited by TUV Rheinland Shenzhen, 2010.5.25
The Laboratory has been assessed according to the requirements ISO/IEC 17025.
 - : Accredited by FCC, October 28, 2010
The Certificate Registration Number is 406365.
 - : Accredited by FCC, February 28, 2013
The Certificate Registration Number is 709623.
 - : Accredited by Industry Canada, May 24, 2008
The Certificate Registration Number is 4480A-2

6 TEST SYSTEM UNCERTAINTY

The following measurement uncertainty levels have been estimated for tests performed on the apparatus:

Parameter	Uncertainty
Radio Frequency	$\pm 1 \times 10^{-5}$
Maximum Peak Output Power Test	$\pm 1.0 \text{dB}$
Conducted Emissions Test	$\pm 2.0 \text{dB}$
Radiated Emission Test	$\pm 2.0 \text{dB}$
Occupied Bandwidth Test	$\pm 1.0 \text{dB}$
Band Edge Test	$\pm 3 \text{dB}$
All emission, radiated	$\pm 3 \text{dB}$
Antenna Port Emission	$\pm 3 \text{dB}$
Temperature	$\pm 0.5^\circ \text{C}$
Humidity	$\pm 3\%$

Measurement Uncertainty for a level of Confidence of 95%

7 SETUP OF EQUIPMENT UNDER TEST

7.1 RADIO FREQUENCY TEST SETUP 1

The Bluetooth v2.0 /v2.1/v3.0 component's antenna ports(s) of the EUT are connected to the measurement instrument per an appropriate attenuator. The EUT is controlled by PC/software to emit the specified signals for the purpose of measurements.

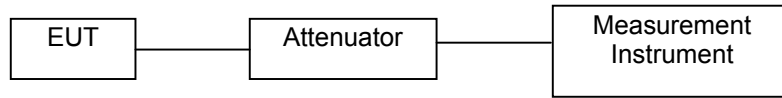

7.2 RADIO FREQUENCY TEST SETUP 2

The test site semi-anechoic chamber has met the requirement of NSA tolerance 4 dB according to the standards: ANSI C63.4. The test distance is 3m. The setup is according to the requirements in Section 13.1.4.1 of ANSI C63.4-2014 and CAN/CSA-CEI/IEC CISPR 22.

The maximal emission value is acquired by adjusting the antenna height, polarisation and turntable azimuth. Normally, the height range of antenna is 1 m to 4 m, the azimuth range of turntable is 0° to 360°, and the receive antenna has two polarizations Vertical (V) and Horizontal (H).

(a) Radiated Emission Test Set-Up, Frequency Below 30MHz

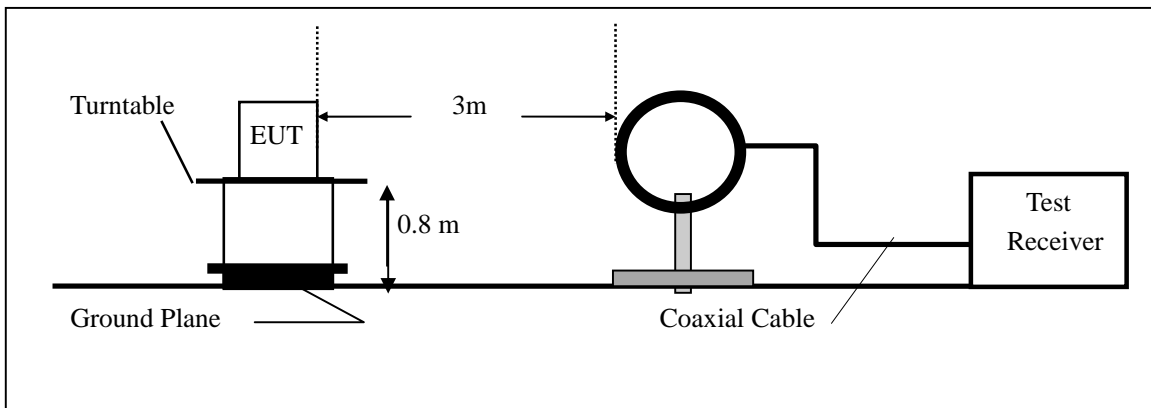

(b) Radiated Emission Test Set-Up, Frequency Below 1000MHz

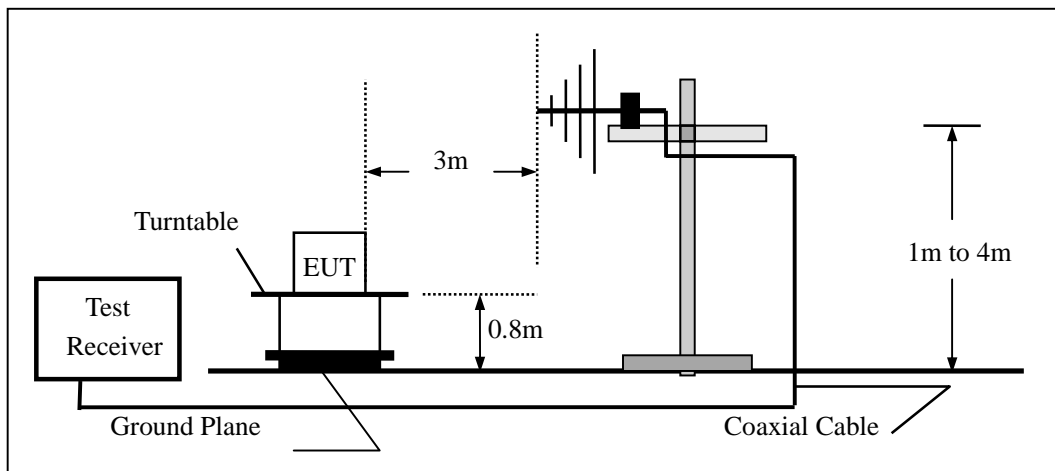

(c) Radiated Emission Test Set-Up, Frequency above 1000MHz
For FCC:

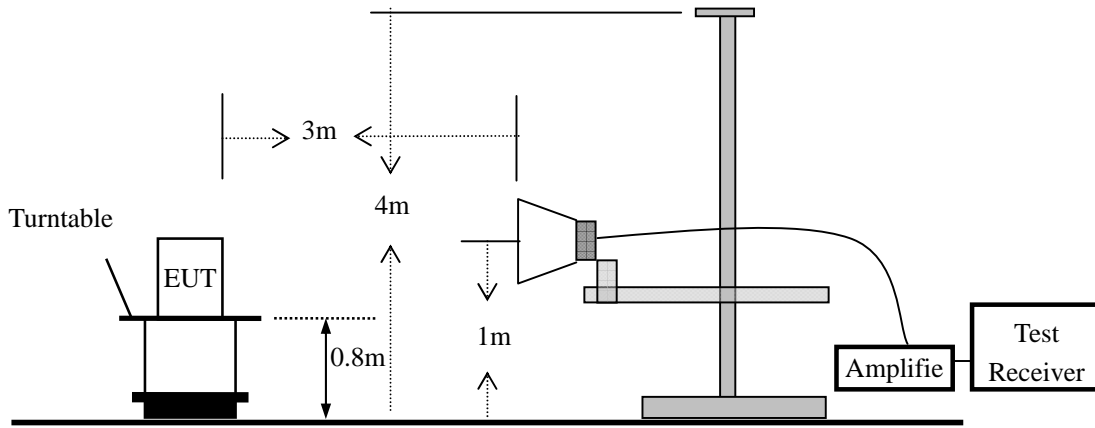

For IC:

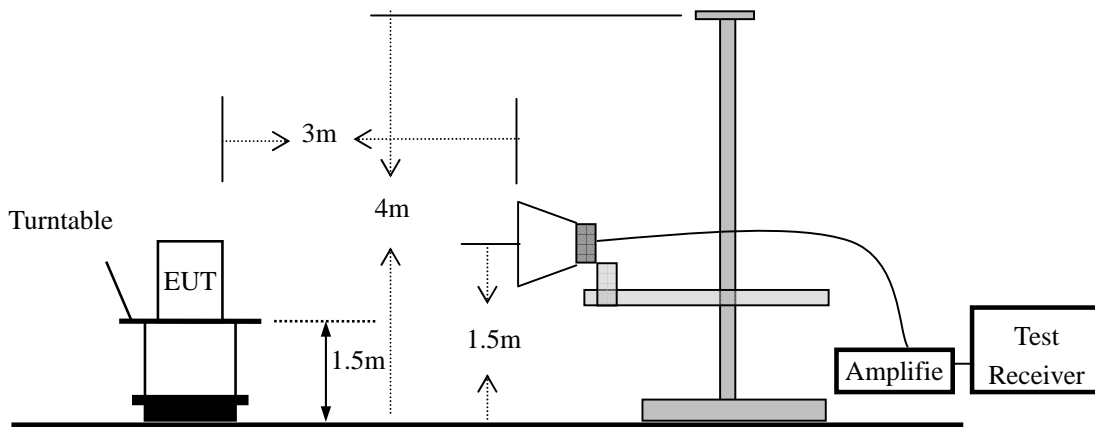

7.3 CONDUCTED EMISSION TEST SETUP

The mains cable of the EUT (Tablet PC) must be connected to LISN. The LISN shall be placed 0.8 m from the boundary of EUT and bonded to a ground reference plane for LISN mounted on top of the ground reference plane. This distance is between the closest points of the LISN and the EUT. All other units of the EUT and associated equipment shall be at least 0.8m from the LISN.

Ground connections, where required for safety purposes, shall be connected to the reference ground point of the LISN and, where not otherwise provided or specified by the manufacturer, shall be of same length as the mains cable and run parallel to the mains connection at a separation distance of not more than 0.1 m.

According to the requirements in Section 13.1.4.1 of ANSI C63.4-2014 Conducted emissions from the EUT measured in the frequency range between 0.15 MHz and 30 MHz using CISPR Quasi-Peak and average detector mode.

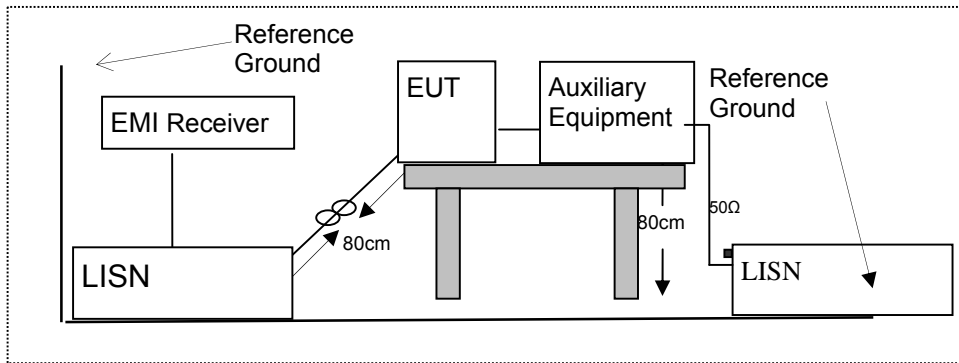

7.4 BLOCK DIAGRAM CONFIGURATION OF TEST SYSTEM

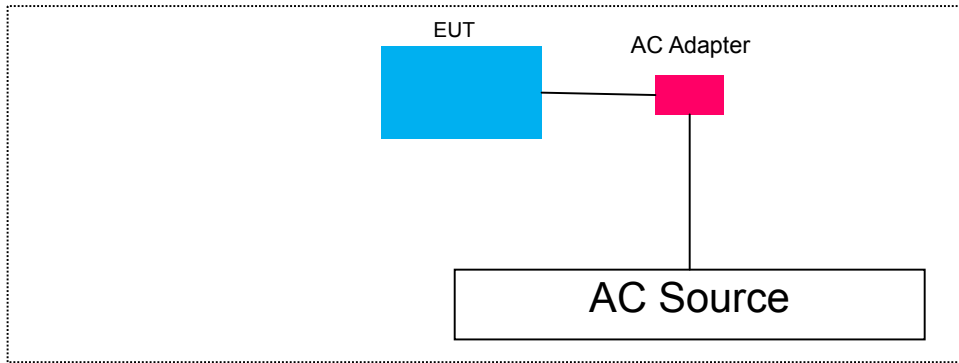

7.5 SUPPORT EQUIPMENT

Item	Equipment	Mfr/Brand	Model/Type No.	Series No.	Note

Notes:

1. All the equipment/cables were placed in the worst-case configuration to maximize the emission during the test.
2. Grounding was established in accordance with the manufacturer's requirements and conditions for the intended use.

8 FREQUENCY HOPPING SYSTEM REQUIREMENTS

8.1 Standard Applicable

According to FCC Part 15.247(a)(1), The system shall hop to channel frequencies that are selected at the system hopping rate from a pseudo randomly ordered list of hopping frequencies. Each frequency must be used equally on the average by each transmitter. The system receivers shall have input bandwidths that match the hopping channel bandwidths of their corresponding transmitters and shall shift frequencies in synchronization with the transmitted signals.

(g) Frequency hopping spread spectrum systems are not required to employ all available hopping channels during each transmission. However, the system, consisting of both the transmitter and the receiver, must be designed to comply with all of the regulations in this section should the transmitter be presented with a continuous data (or information) stream. In addition, a system employing short transmission bursts must comply with the definition of a frequency hopping system and must distribute its transmissions over the minimum number of hopping channels specified in this section.

(h) The incorporation of intelligence within a frequency hopping spread spectrum system that permits the system to recognize other users within the spectrum band so that it individually and independently chooses and adapts its hopsets to avoid hopping on occupied channels is permitted. The coordination of frequency hopping systems in any other manner for the express purpose of avoiding the simultaneous occupancy of individual hopping frequencies by multiple transmitters is not permitted.

8.2 EUT Pseudorandom Frequency Hopping Sequence

The pseudorandom sequence may be generated in a nine-stage shift register whose 5th and 9th stage outputs are added in a modulo-two addition stage, and the result is fed back to the input of the first stage. The sequence begins with the first ONE of 9 consecutive ONES; i.e. the shift register is initialized with nine ones. Number of shift register stages: 9
Length of pseudo-random sequence: $2^9 - 1 = 511$ bits
Longest sequence of zeros: 8 (non-inverted signal)

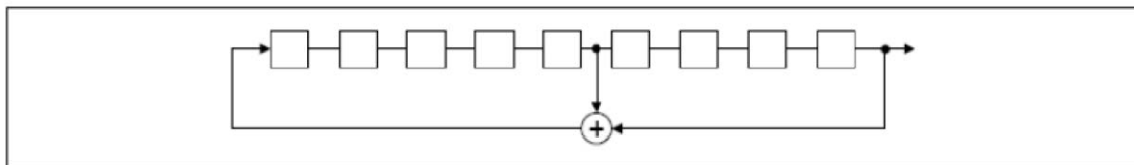

Linear Feedback Shift Register for Generation of the PRBS sequence

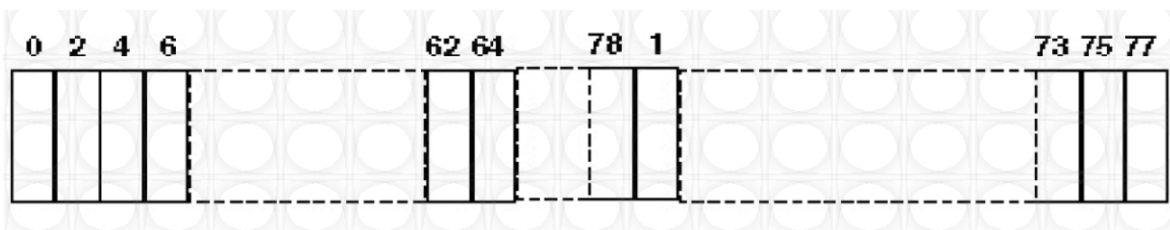

Each frequency used equally on the average by each transmitter.
The system receiver have input bandwidths that match the hopping channel bandwidths of their corresponding transmitters and shift frequencies in synchronization with the transmitted signals.

8.3 Frequency Hopping System

This transmitter device is frequency hopping device, and complies with FCC part 15.247 rule.

This device uses Bluetooth radio which operates in 2400-2483.5 MHz band. Bluetooth uses a radio technology called frequency-hopping spread spectrum, which chops up the data being sent and transmits chunks of it on up to 79 bands (1 MHz each; centred from 2402 to 2480 MHz) in the range 2,400-2,483.5 MHz. The transmitter switches hop frequencies 1,600 times per second to assure a high degree of data security. All Bluetooth devices participating in a given piconet are synchronized to the frequency-hopping channel for the piconet. The frequency hopping sequence is determined by the master's device address and the phase of the hopping sequence (the frequency to hop at a specific time) is determined by the master's internal clock. Therefore, all slaves in a piconet must know the master's device address and must synchronize their clocks with the master's clock.

Adaptive Frequency Hopping (AFH) was introduced in the Bluetooth specification to provide an effective way for a Bluetooth radio to counteract normal interference. AFH identifies "bad" channels, where either other wireless devices are interfering with the Bluetooth signal or the Bluetooth signal is interfering with another device. The AFH-enabled Bluetooth device will then communicate with other devices within its piconet to share details of any identified bad channels. The devices will then switch to alternative available "good" channels, away from the areas of interference, thus having no impact on the bandwidth used.

9 TEST REQUIREMENTS

9.1 20 DB BANDWIDTH

9.1.1 Applicable Standard

According to FCC Part 15.247(a)(1) and DA 00-705 / IC RSS-210.A8.1(a)

9.1.2 Conformance Limit

No limit requirement.

9.1.3 Test Configuration

Test according to clause 7.1 radio frequency test setup 1

9.1.4 Test Procedure

The EUT was operating in Bluetooth v2.0 /v2.1/v3.0 mode and controlled its channel. Printed out the test result from the spectrum by hard copy function.

The RF output of EUT was connected to the spectrum analyzer by RF cable and attenuator. The path loss was compensated to the results for each measurement.

Set to the maximum power setting and enable the EUT transmit continuously

Set RBW = 30 kHz.

Set the video bandwidth (VBW) =100 kHz.

Set Span= approximately 2 to 3 times the 20 dB bandwidth

Set Detector = Peak.

Set Trace mode = max hold.

Set Sweep = auto couple.

The EUT should be transmitting at its maximum data rate. Allow the trace to stabilize. Use the marker-to-peak function to set the marker to the peak of the emission. Use the marker-delta function to measure 20 dB down one side of the emission. Reset the markerdelta function, and move the marker to the other side of the emission, until it is (as close as possible to) even with the reference marker level. The marker-delta reading at this point is the 20 dB bandwidth of the emission.

If this value varies with different modes of operation (e.g., data rate, modulation format, etc.), repeat this test for each variation.

Measure and record the results in the test report.

Test Results

Temperature: 24 °C

Humidity: 53 %

Test Date: December 18, 2014

Test By: KK

Modulation Mode	Channel Number	Channel Frequency (MHz)	Measurement Bandwidth (MHz)
GFSK	0	2402	0.821
	39	2441	0.818
	78	2480	0.835
π /4-DQPSK	0	2402	1.135
	39	2441	1.137
	78	2480	1.133
8DPSK	0	2402	1.172
	39	2441	1.175
	78	2480	1.174

Test Model	20dB Bandwidth	
	GFSK Modulation	Channel 0: 2402MHz

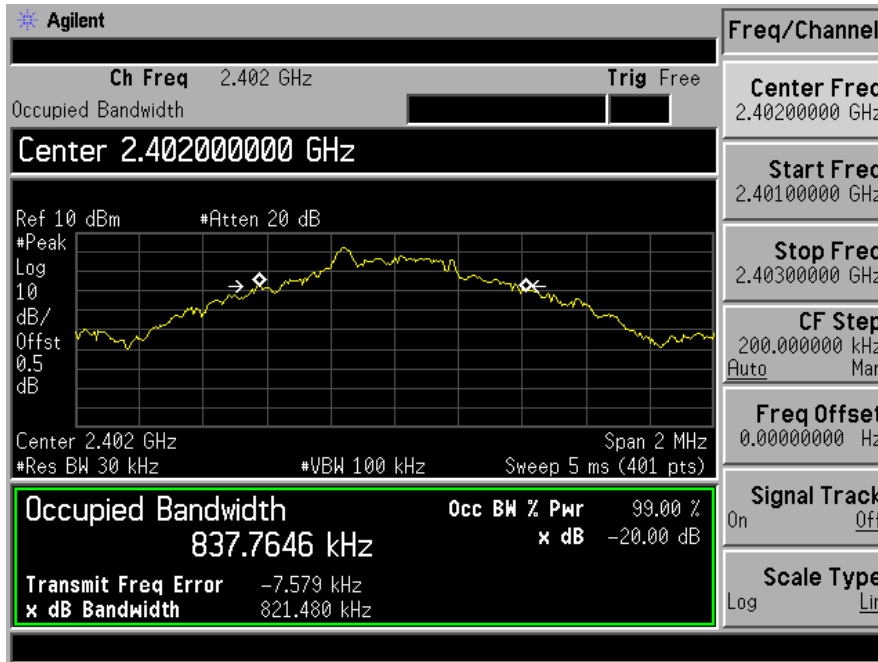

Test Model	20dB Bandwidth	
	GFSK Modulation	Channel 39: 2441MHz

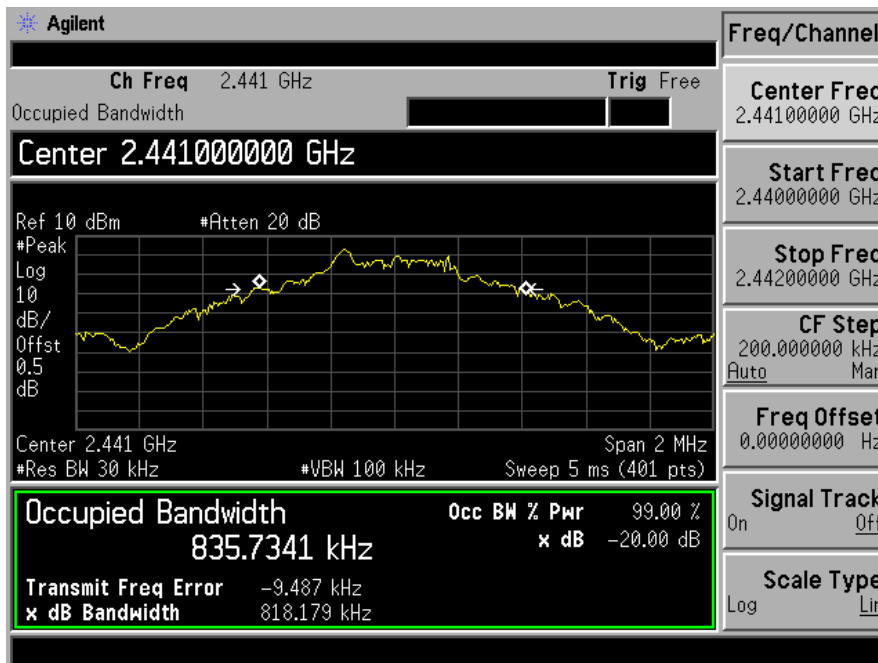

Test Model	20dB Bandwidth	
	GFSK Modulation	Channel 78: 2480MHz

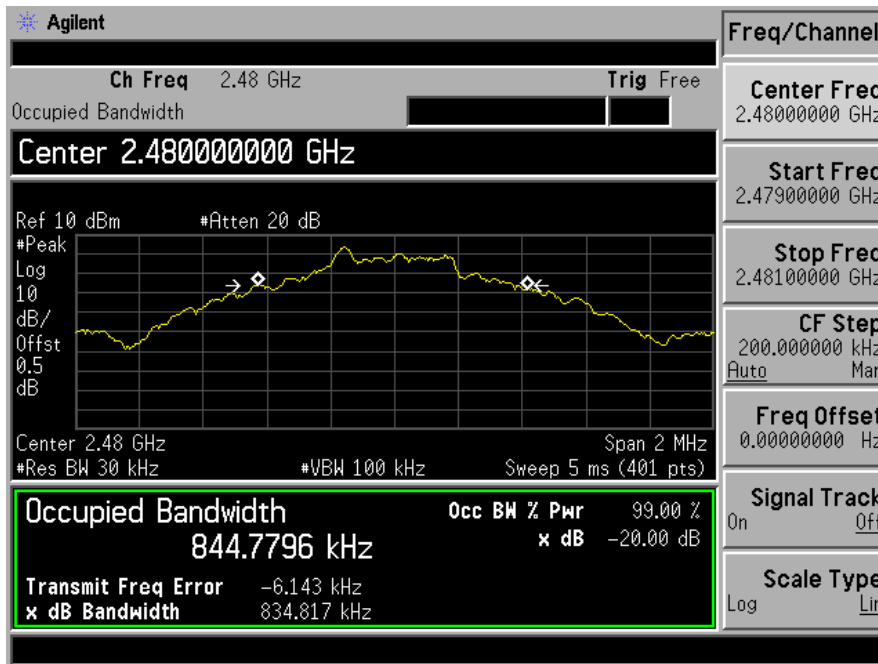

Test Model	20dB Bandwidth	
	π /4-DQPSK Modulation	Channel 0: 2402MHz



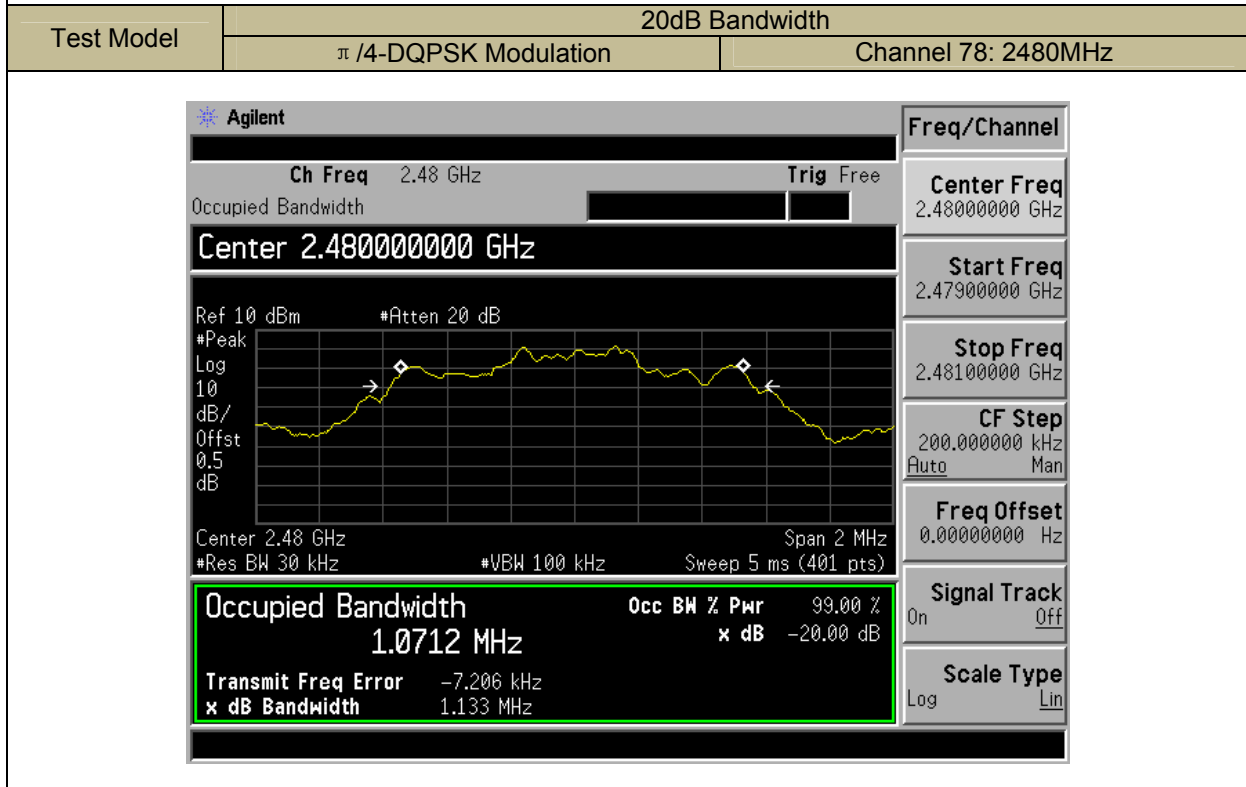
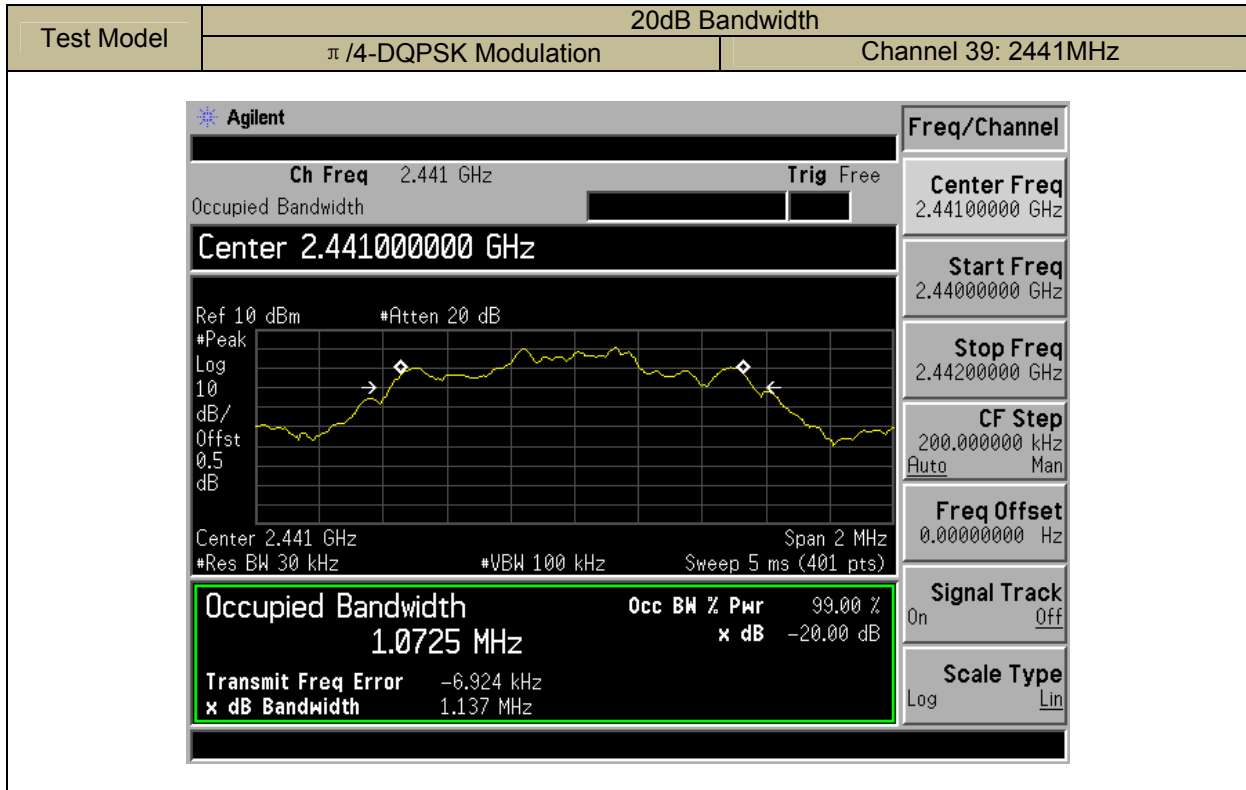

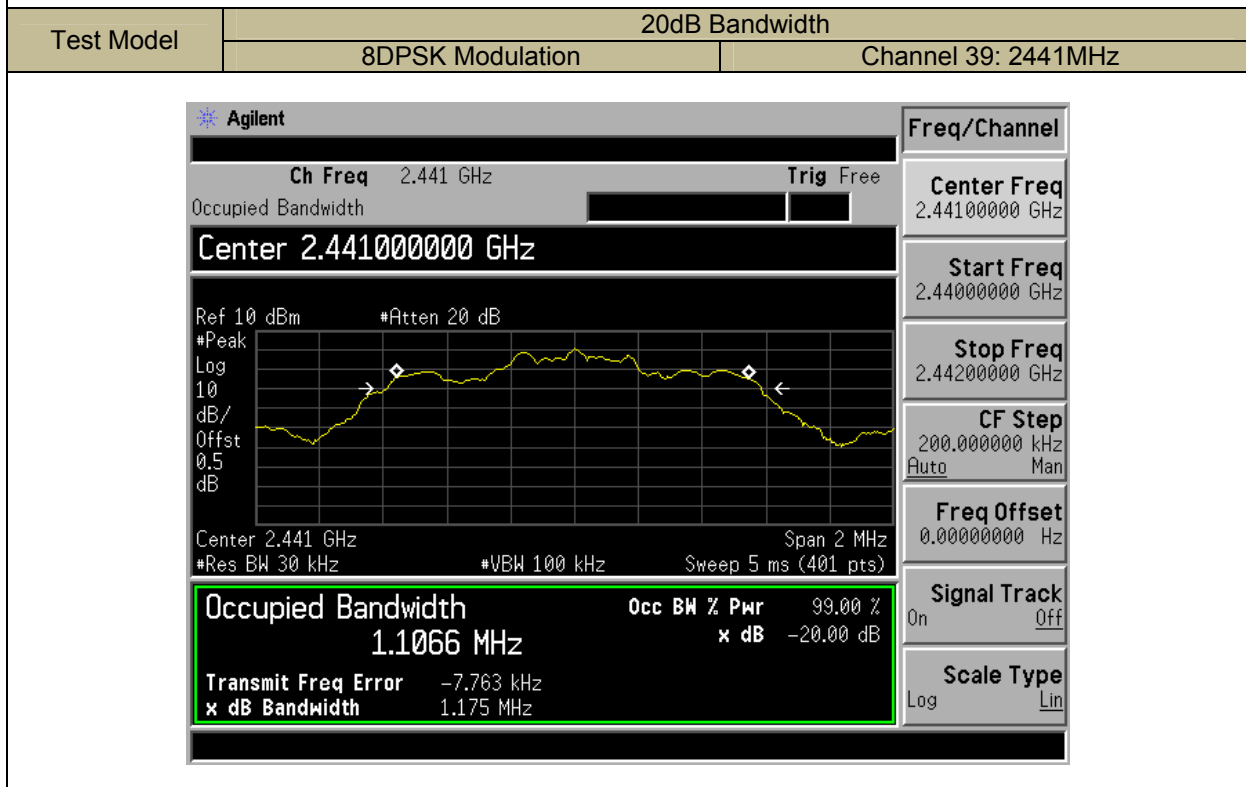
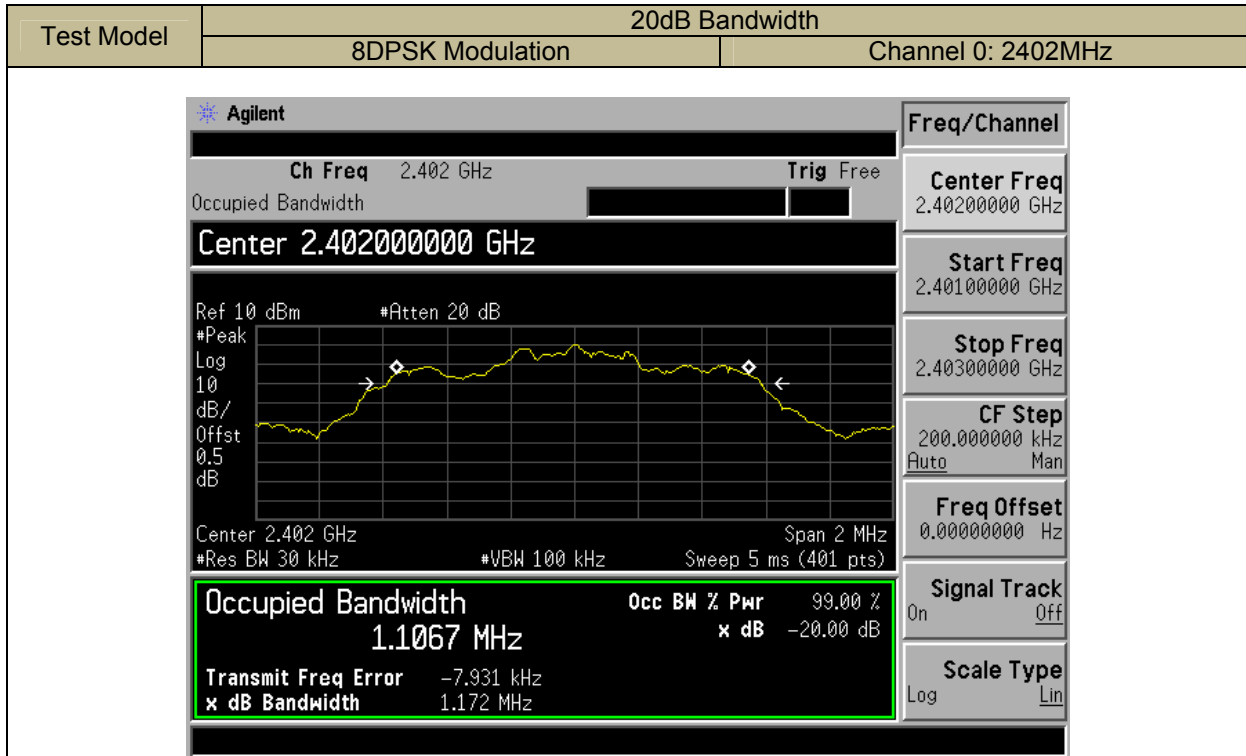

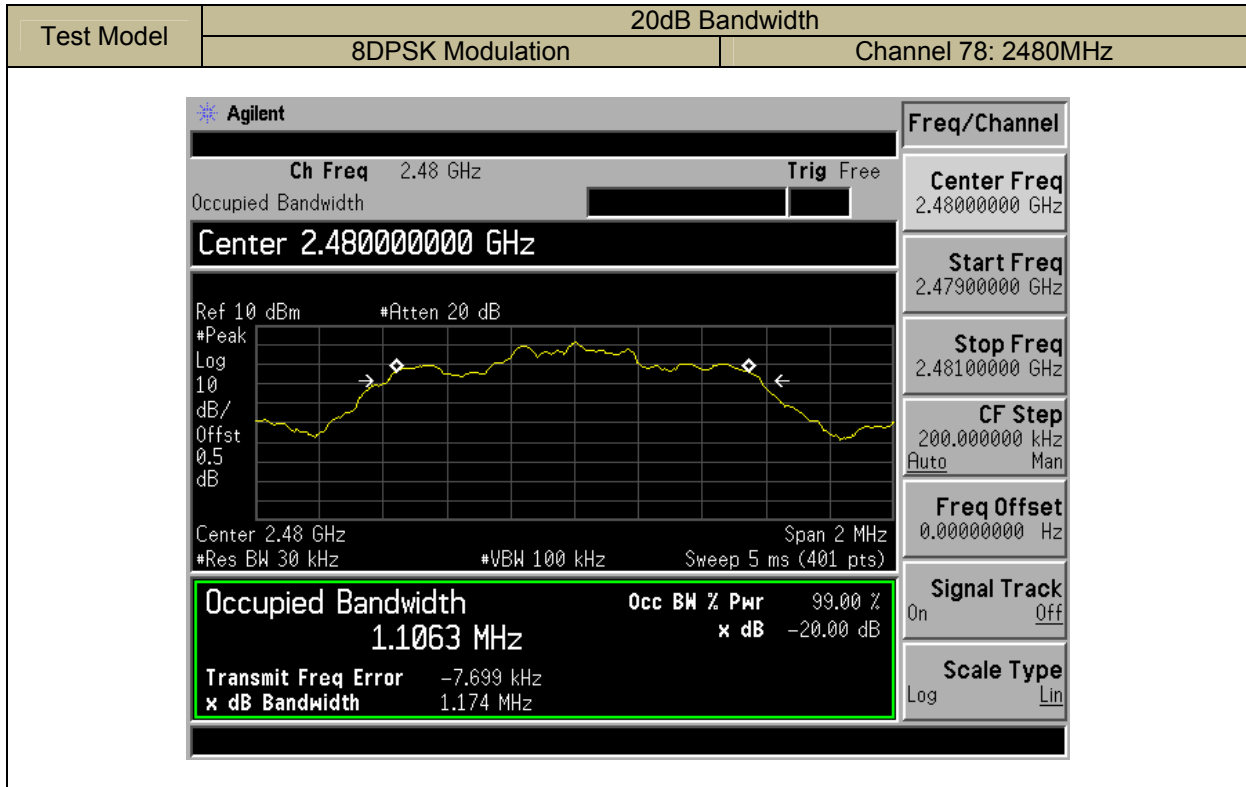

9.2 99% OCCUPIED BANDWIDTH

9.2.1 Applicable Standard

According to IC RSS-Gen 6.6

9.2.2 Conformance Limit

No limit requirement.

9.2.3 Test Configuration

Test according to clause 7.1 radio frequency test setup 1

9.2.4 Test Procedure

The EUT was operating in Bluetooth v2.0 /v2.1/v3.0 mode and controlled its channel. Printed out the test result from the spectrum by hard copy function.

The RF output of EUT was connected to the spectrum analyzer by RF cable and attenuator. The path loss was compensated to the results for each measurement.

Set to the maximum power setting and enable the EUT transmit continuously

Set RBW = 100 kHz.

Set the video bandwidth (VBW) =300 kHz.

Set Span= approximately 2 to 3 times the 20 dB bandwidth

Set Detector = Peak.

Set Trace mode = max hold.

Set Sweep = auto couple.

The EUT should be transmitting at its maximum data rate. Allow the trace to stabilize. Use the marker-to-peak function to set the marker to the peak of the emission. Use the marker-delta function to measure 20 dB down one side of the emission. Reset the markerdelta function, and move the marker to the other side of the emission, until it is (as close as possible to) even with the reference marker level. The marker-delta reading at this point is the 20 dB bandwidth of the emission.

If this value varies with different modes of operation (e.g., data rate, modulation format, etc.), repeat this test for each variation.

Measure and record the results in the test report.

Test Results

Temperature: 24 °C
Humidity: 53 %

Test Date: December 18, 2014
Test By: KK

Modulation Mode	Channel Number	Channel Frequency (MHz)	Measurement Bandwidth (MHz)
GFSK	0	2402	0.838
	39	2441	0.836
	78	2480	0.845
π /4-DQPSK	0	2402	1.0721
	39	2441	1.0725
	78	2480	1.0712
8DPSK	0	2402	1.1067
	39	2441	1.1066
	78	2480	1.1063

Note: The test plots please refer to clause 9.1.

9.3 CARRIER FREQUENCY SEPARATION

9.3.1 Applicable Standard

According to FCC Part 15.247(a)(1) and DA 00-705 / IC RSS-210.A8.1(b)

9.3.2 Conformance Limit

Frequency hopping systems operating in the 2400-2483.5MHz band shall have hopping channel carrier frequencies separated by a minimum of 25kHz or the 20dB bandwidth of the hopping channel, whichever is greater.

In case of an output power less than 125mW, the frequency hopping system may have channels separated by a minimum of 25kHz or two-thirds of the 20dB bandwidth of the hopping channel, whichever is greater.

9.3.3 Test Configuration

Test according to clause 7.1 radio frequency test setup 1

9.3.4 Test Procedure

- According to FCC Part15.247(a)(1)
 The EUT must have its hopping function enabled. Use the following spectrum analyzer settings:
 Set the RBW =100kHz. Set VBW =300kHz.
 Set the span = wide enough to capture the peaks of two adjacent channels
 Set Sweep time = auto couple.
 Set Detector = peak. Set Trace mode = max hold.
 Allow the trace to stabilize. Use the marker-delta function to determine the separation between the peaks of the adjacent channels. The limit is specified in one of the subparagraphs of this Section. Submit this plot.

Test Results

Temperature:	24°C	Test Date:	December 18, 2014
Humidity:	53 %	Test By:	KK

Modulation Mode	Channel Number	Channel Frequency (MHz)	Measurement Bandwidth (MHz)	Limit (MHz)	Verdict
GFSK	0	2402	1.005	>0.821	PASS
	39	2441	1.005	>0.818	PASS
	78	2480	1.005	>0.835	PASS
π /4-DQPSK	0	2402	1.005	>0.757	PASS
	39	2441	1.013	>0.758	PASS
	78	2480	1.005	>0.755	PASS
8DPSK	0	2402	1.005	>0.781	PASS
	39	2441	1.005	>0.783	PASS
	78	2480	1.005	>0.783	PASS

Note:
 For GFSK:
 Limit = 20dB bandwidth
 For π /4-DQPSK, 8DPSK:
 Limit = 20dB bandwidth * 2/3, if it is greater than 25kHz and the output power is less than 125mW (21dBm).

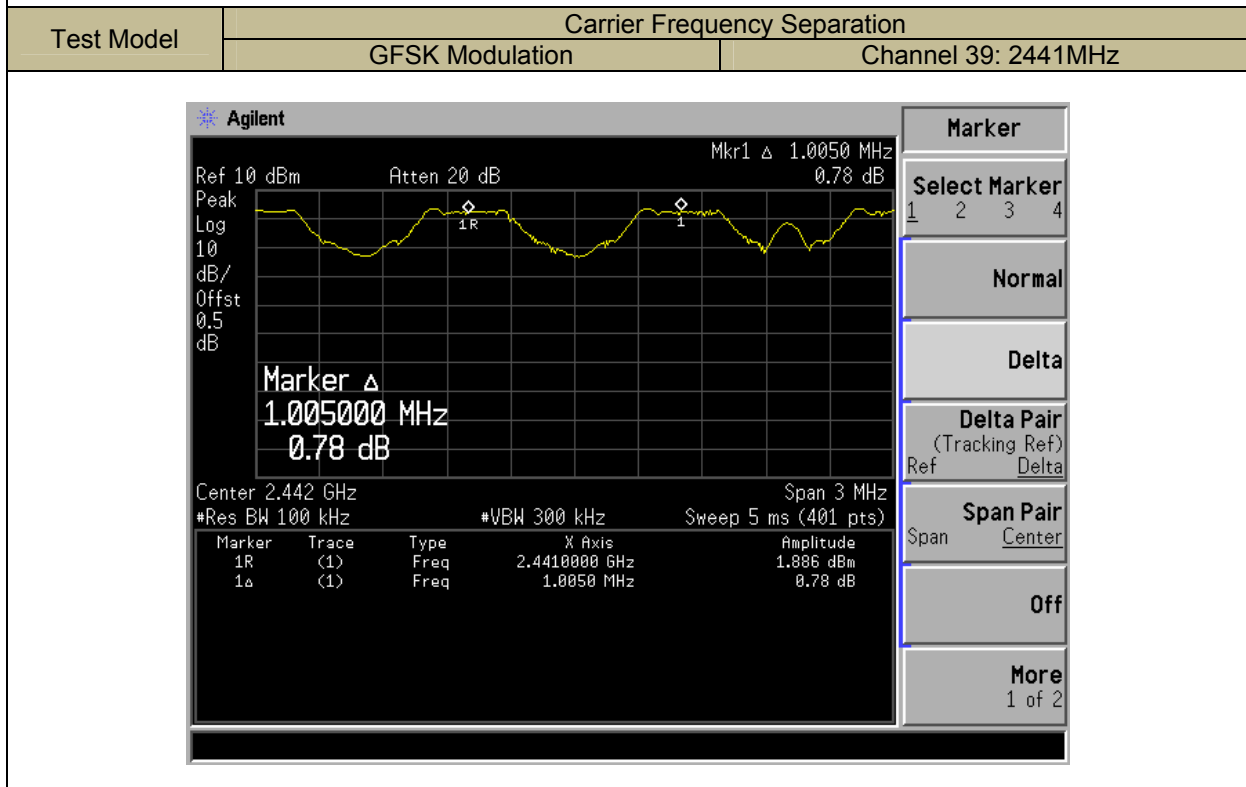
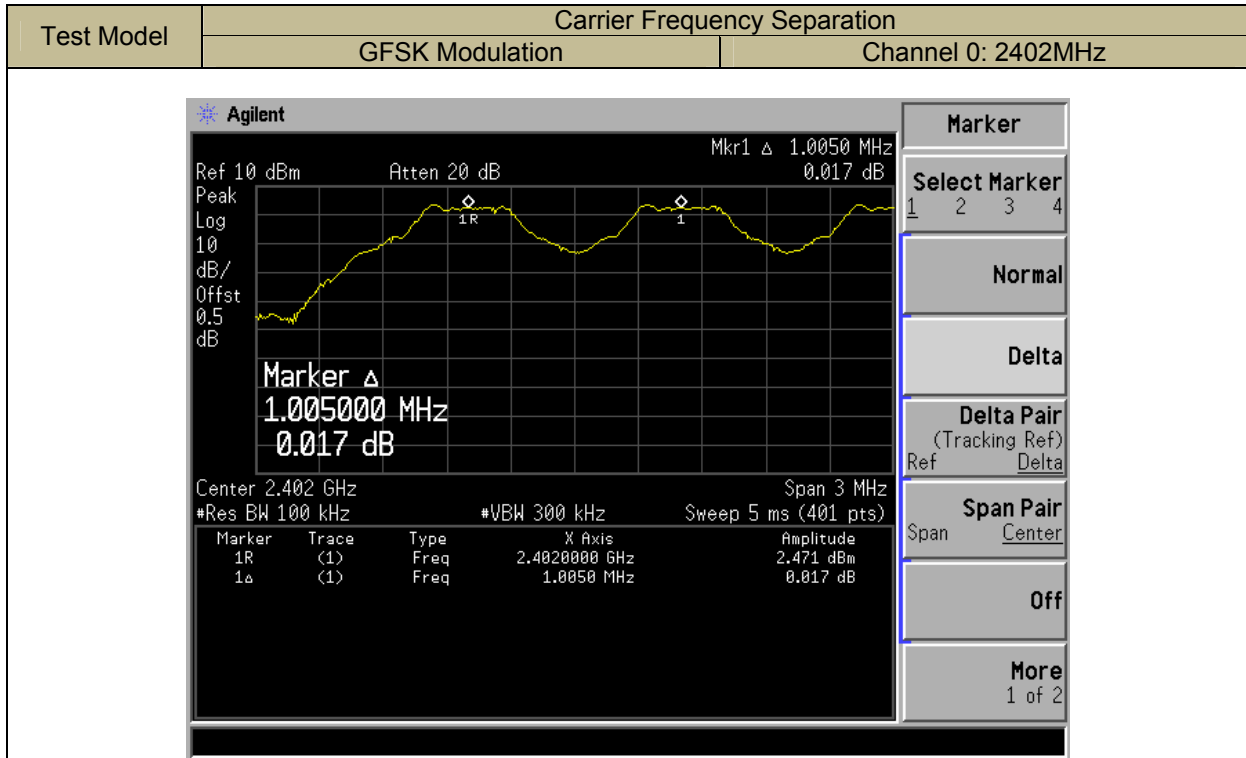

Test Model	Carrier Frequency Separation	
	GFSK Modulation	Channel 78: 2480MHz

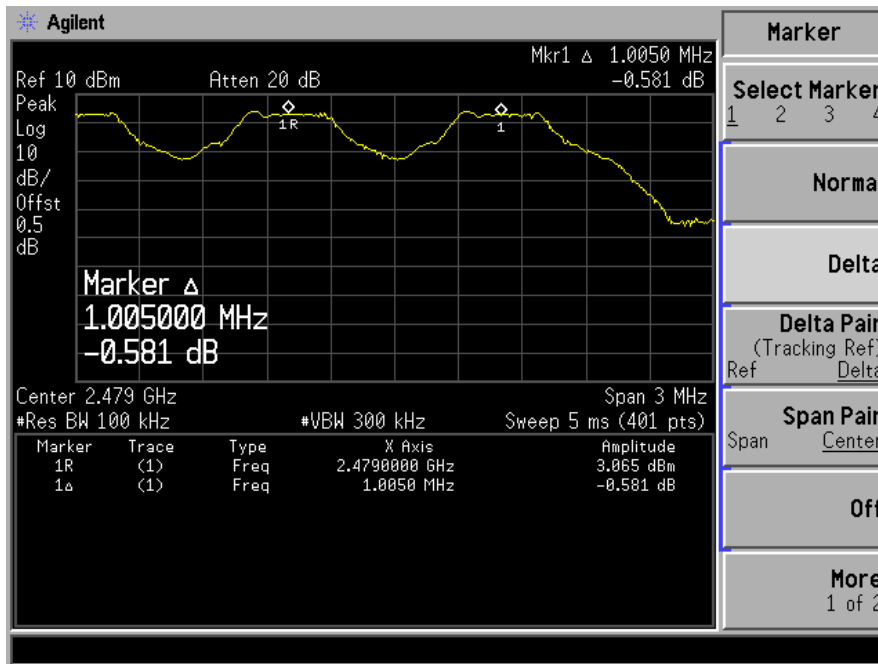

Test Model	Carrier Frequency Separation	
	$\pi/4$ -DQPSK Modulation	Channel 0: 2402MHz

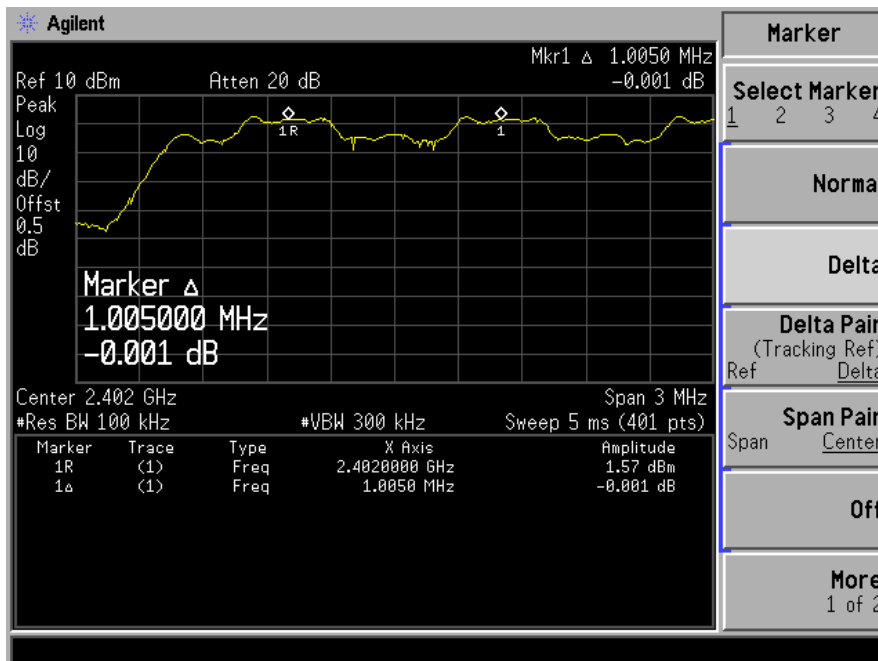

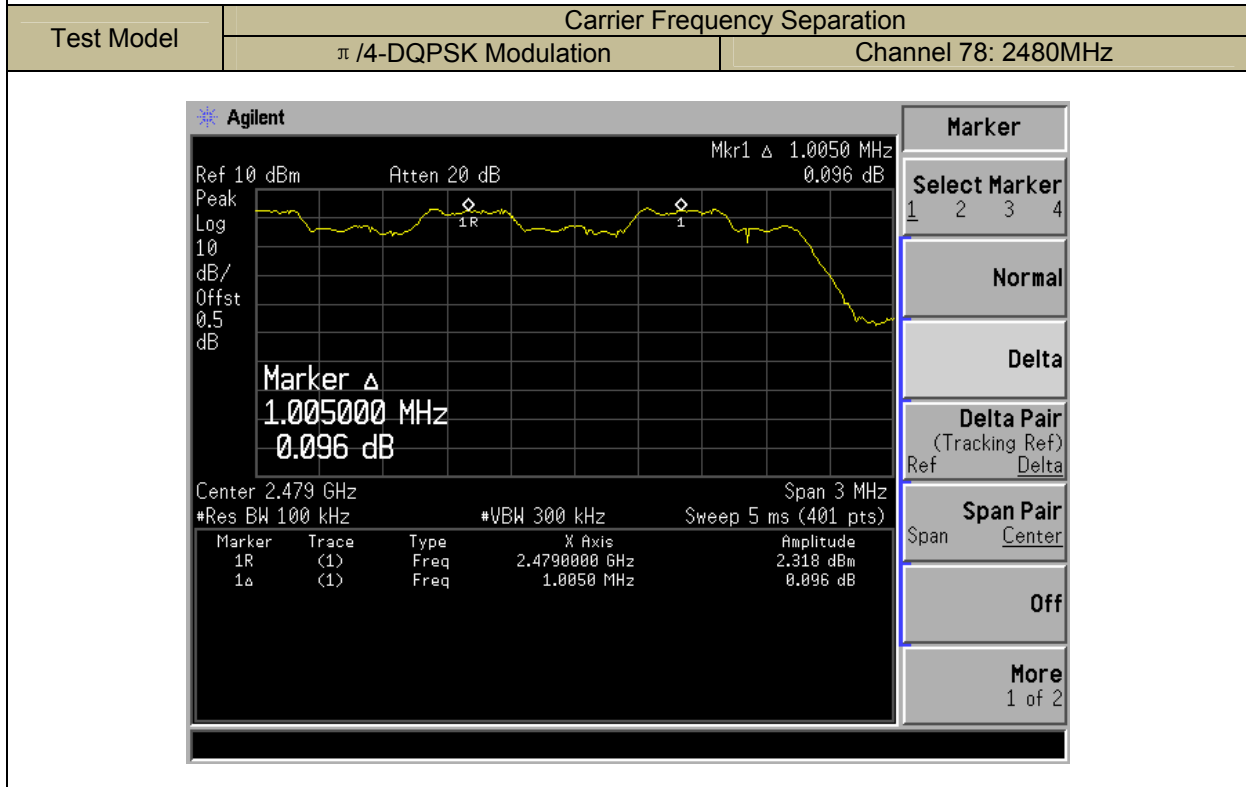
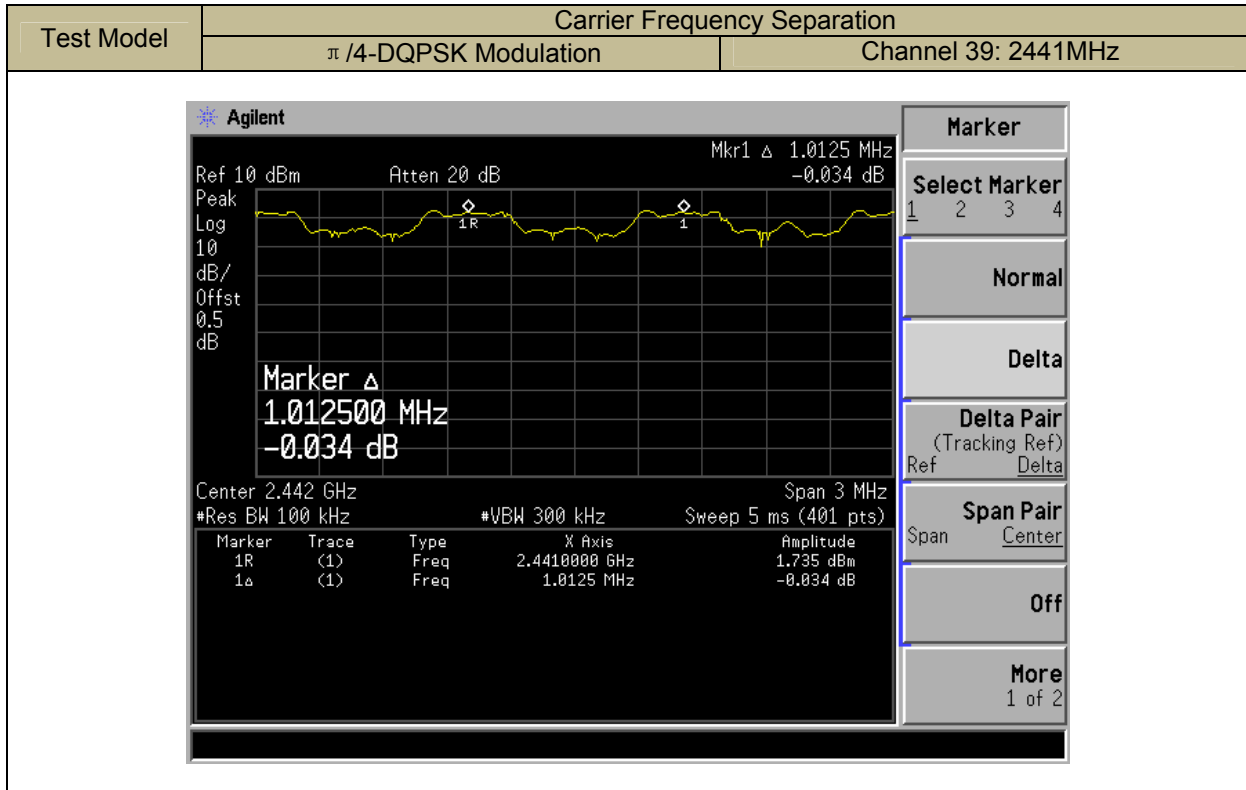

Test Model	Carrier Frequency Separation	
	8DPSK Modulation	Channel 0: 2402MHz

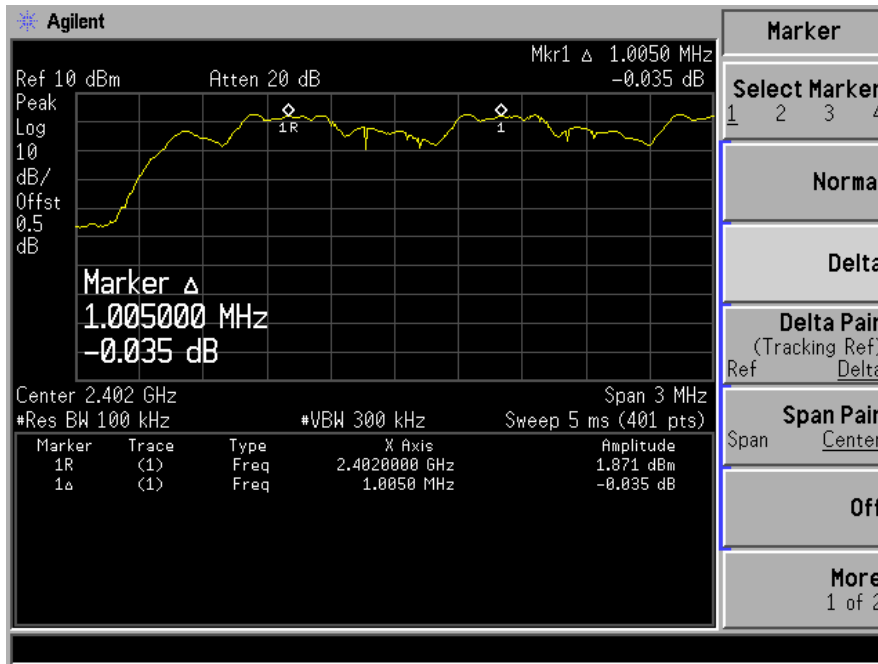

Test Model	Carrier Frequency Separation	
	8DPSK Modulation	Channel 39: 2441MHz

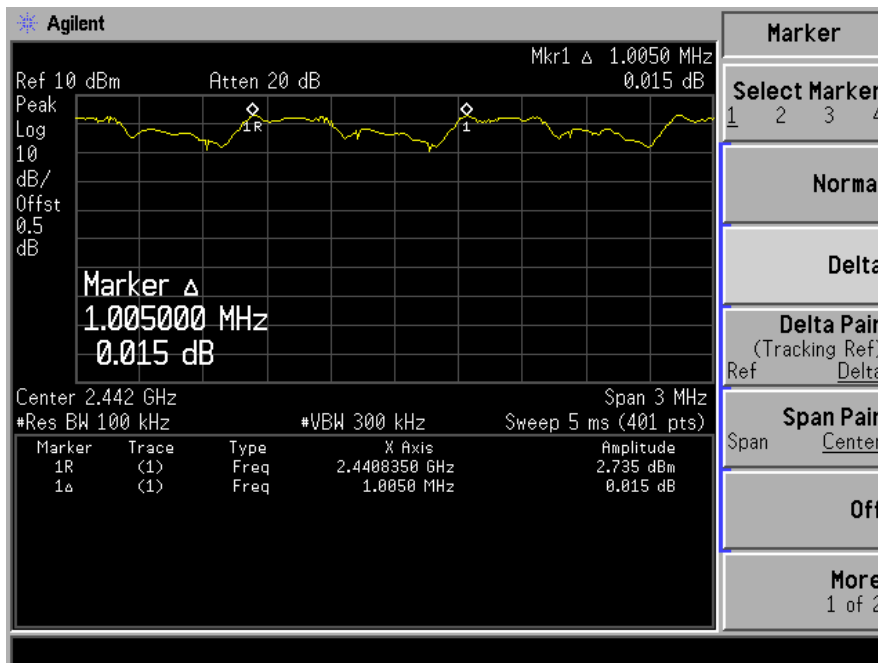

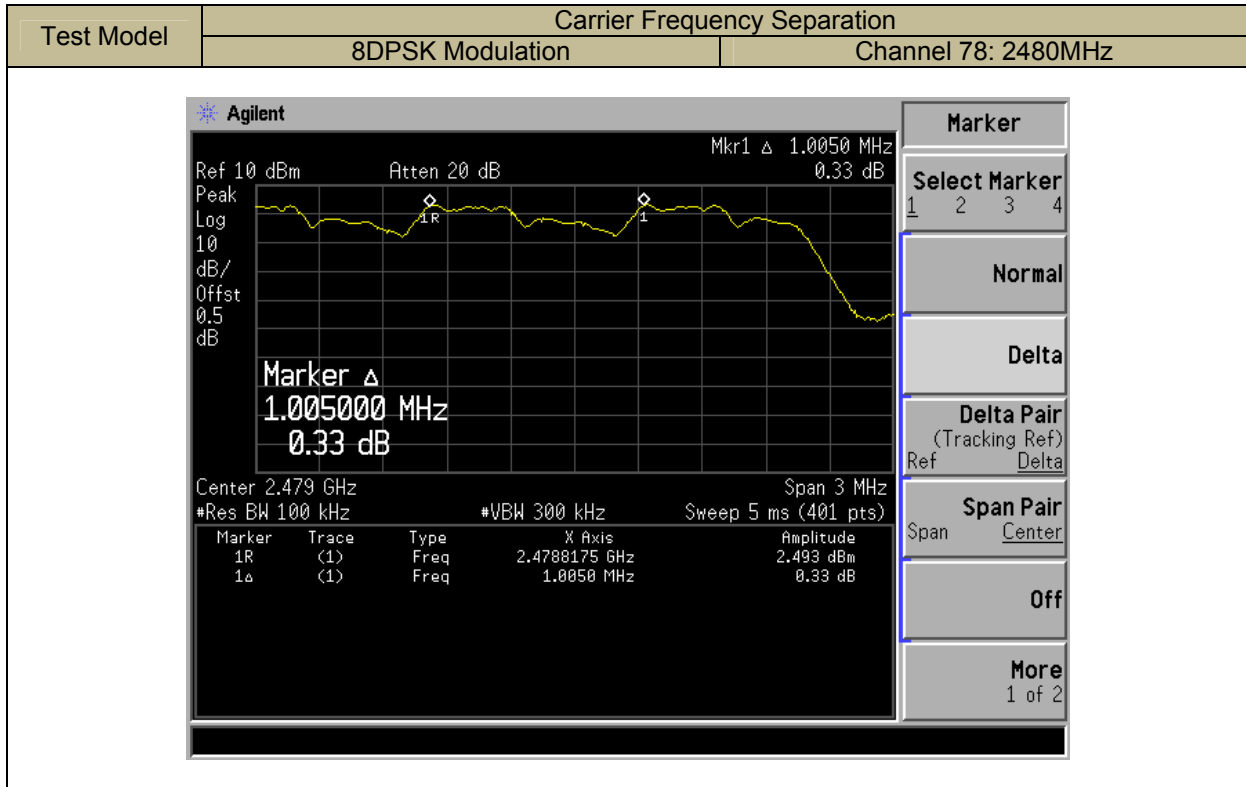

9.4 NUMBER OF HOPPING FREQUENCIES

9.4.1 Applicable Standard

According to FCC Part 15.247(a)(1) (iii) and DA 00-705 / IC RSS-210.A8.1(d)

9.4.2 Conformance Limit

Frequency hopping systems operating in the 2400-2483.5MHz band shall use at least 15 channels.

9.4.3 Test Configuration

Test according to clause 7.1 radio frequency test setup 1

9.4.4 Test Procedure

- According to FCC Part 15.247(a)(1)(iii)

The EUT must have its hopping function enabled. Use the following spectrum analyzer settings:

Span = the frequency band of operation (2390-2440MHz) and (2440-2490MHz)

RBW \geq 1% of the span = 500kHz

VBW \geq RBW

Sweep = auto

Detector function = peak

Trace = max hold

Allow the trace to stabilize. It may prove necessary to break the span up to sections, in order to clearly show all of the hopping frequencies.

Test Results

Spectrum Detector:	PK	Test Date :	December 18, 2014
Test By:	KK	Temperature :	24°C
Test Result:	PASS	Humidity :	53 %

Modulation Mode	Quantity of Hopping Channel	Quantity of Hopping Channel limit
GFSK	79	≥ 15
$\pi/4$ -DQPSK	79	≥ 15
8DPSK	79	≥ 15

Test Model	Number Of Hopping Frequencies
	GFSK
	Span: 2390-2440MHz

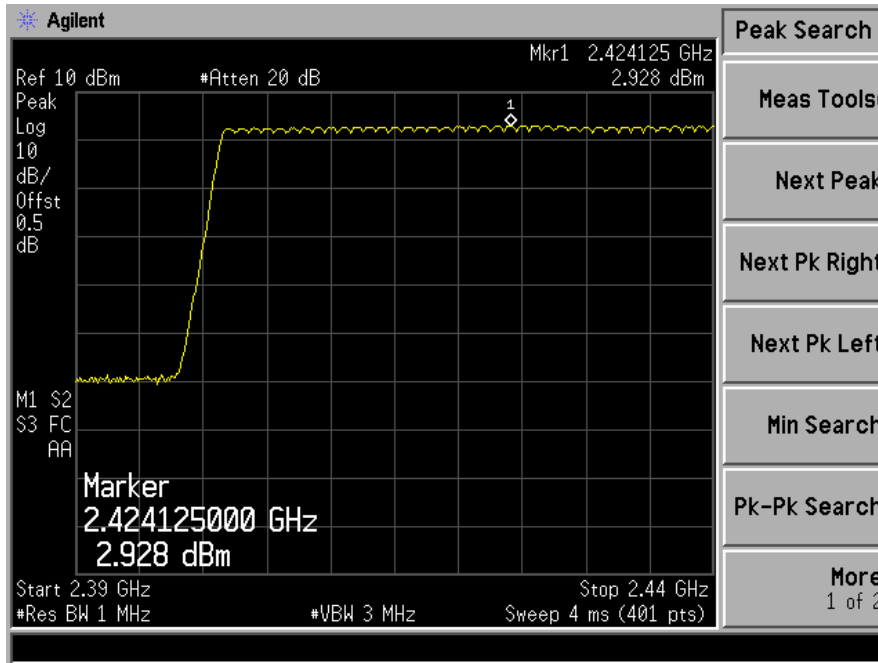

Test Model	Number Of Hopping Frequencies
	GFSK
	Span: 2440-2490MHz

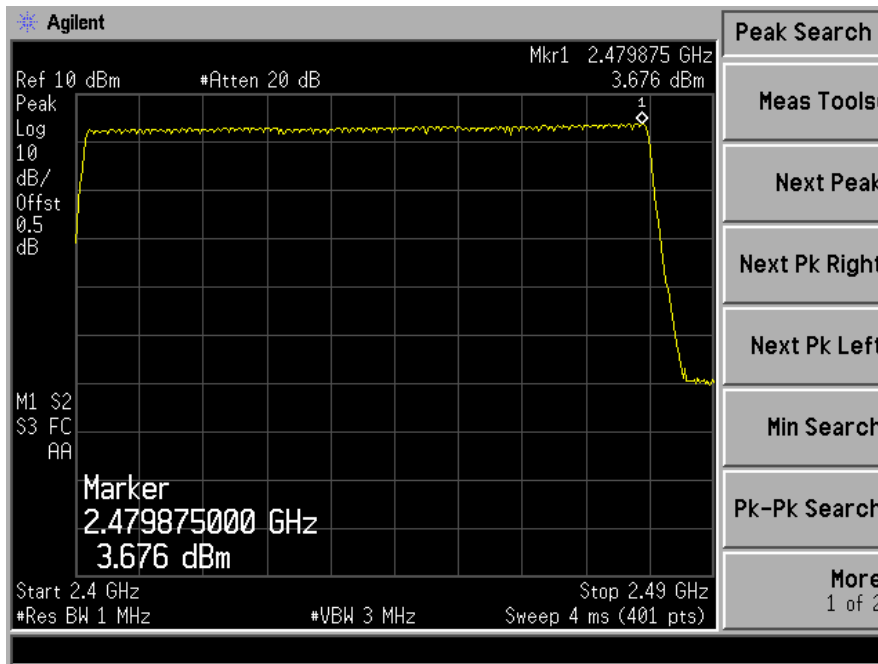

Test Model	Number Of Hopping Frequencies
	$\pi/4$ -DQPSK
	Span: 2390-2440MHz

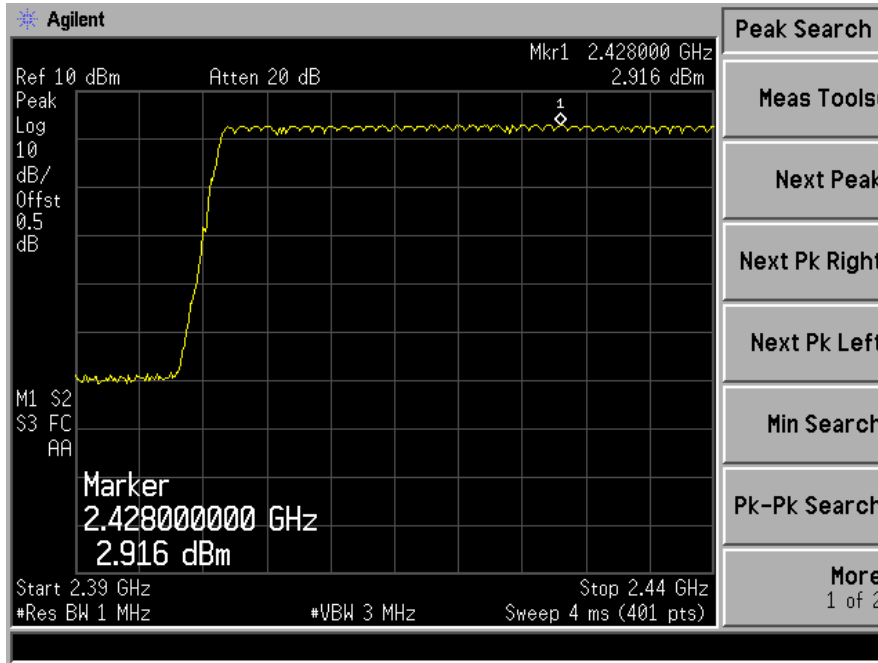

Test Model	Number Of Hopping Frequencies
	$\pi/4$ -DQPSK
	Span: 2440-2490MHz

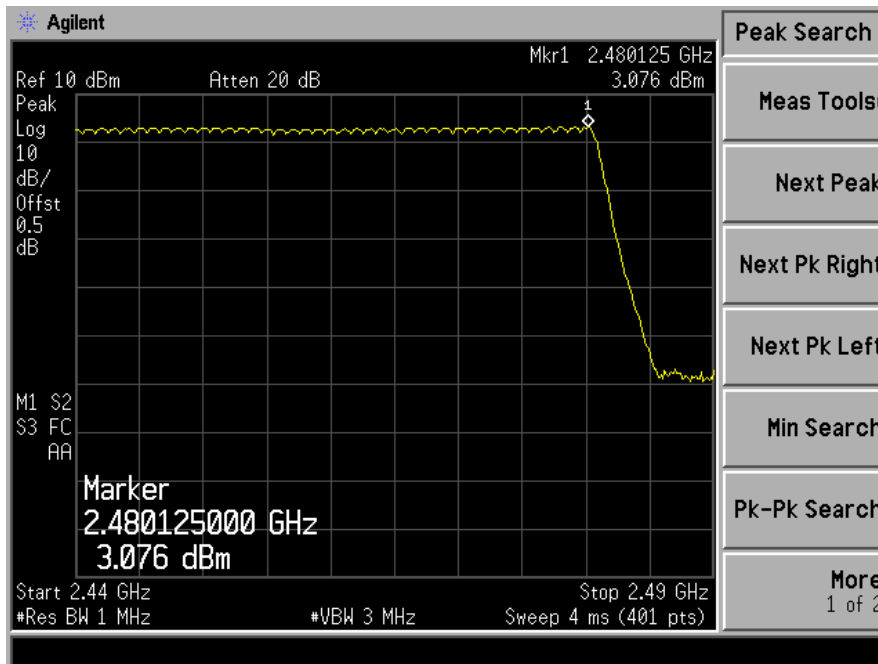

Test Model	Number Of Hopping Frequencies
	8DPSK
	Span: 2390-2440MHz

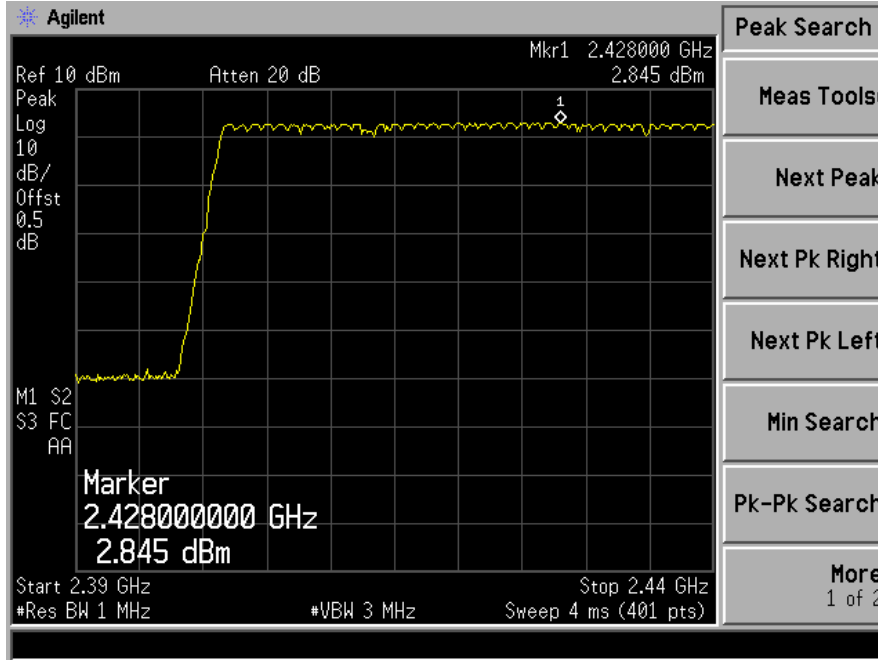

Test Model	Number Of Hopping Frequencies
	8DPSK
	Span: 2440-2490MHz

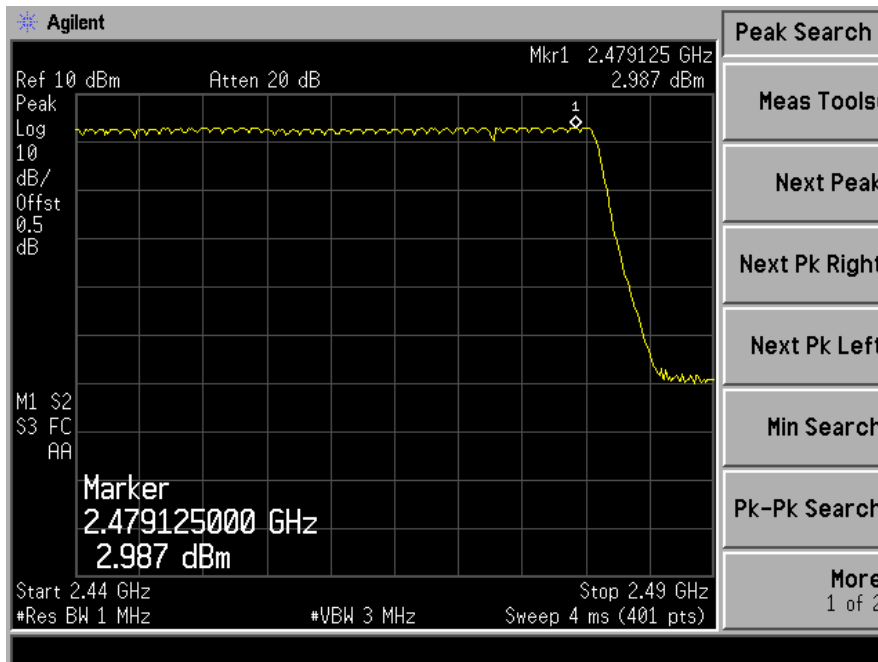

Test Model	Average Time Of Occupancy (Dwell Time)	
	GFSK	
	CH 0: 2402MHz	DH1

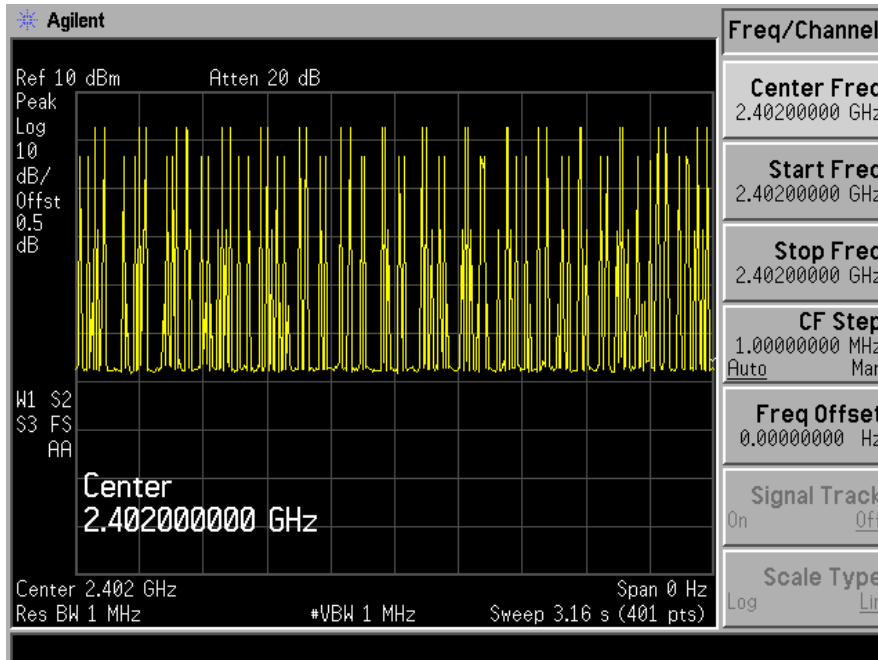
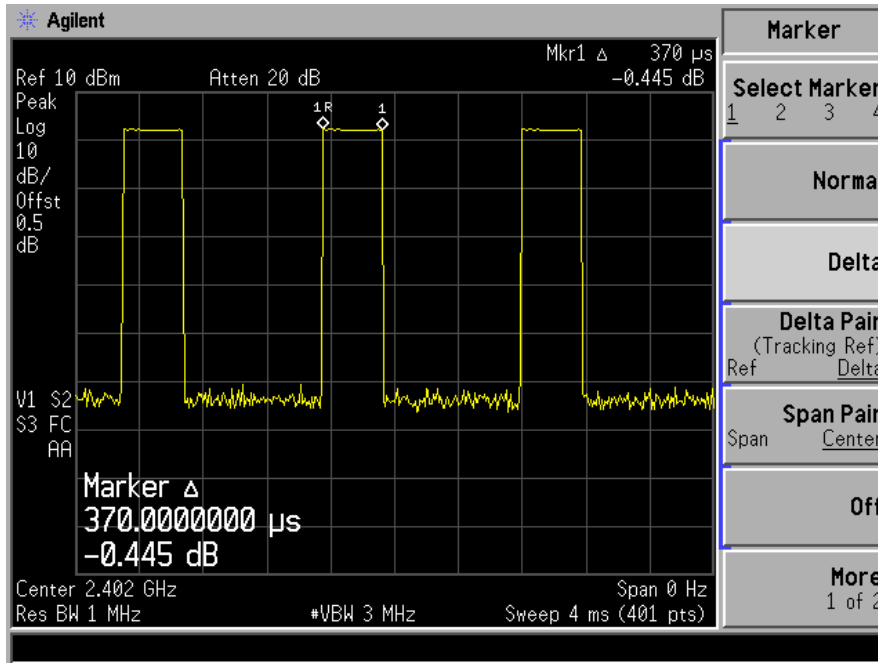

Test Model	Average Time Of Occupancy (Dwell Time)	
	GFSK	
	CH 0: 2402MHz	DH3

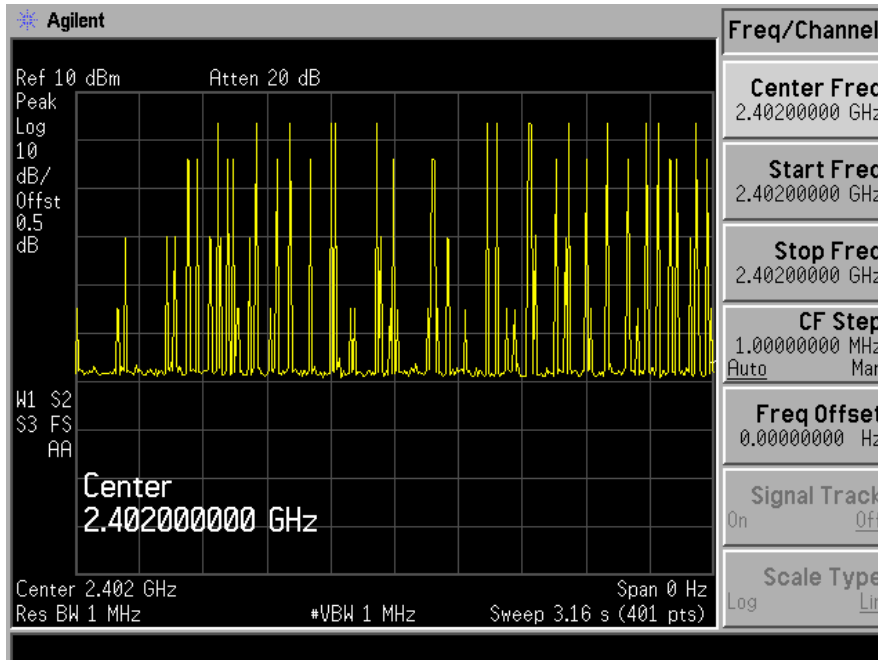
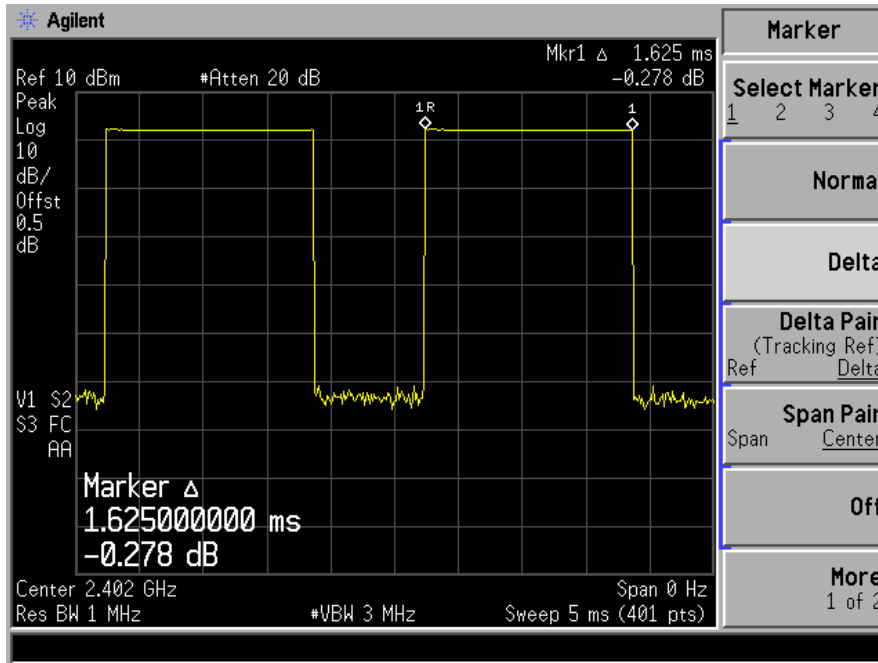

Test Model	Average Time Of Occupancy (Dwell Time)	
	GFSK	
	CH 0: 2402MHz	DH5

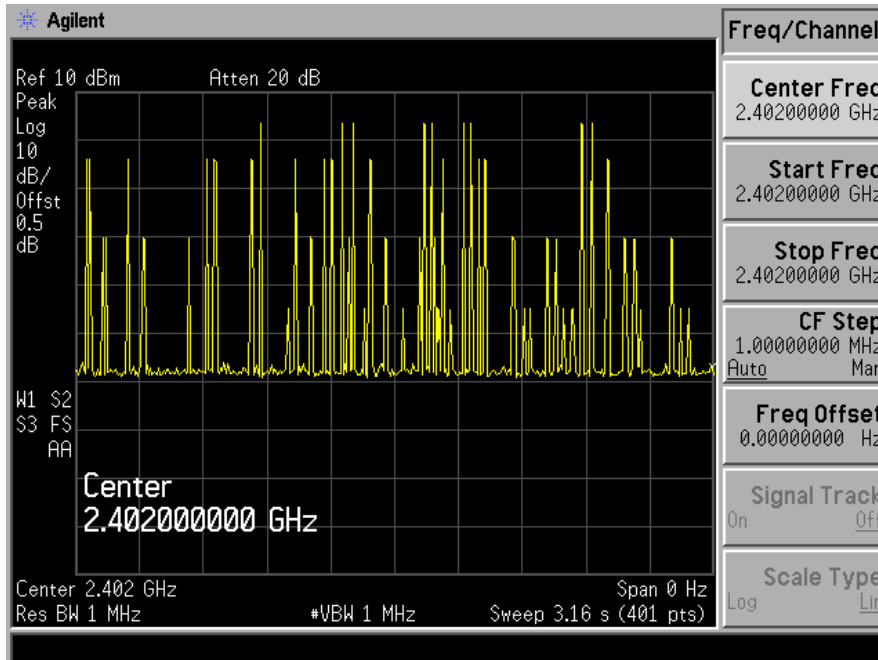
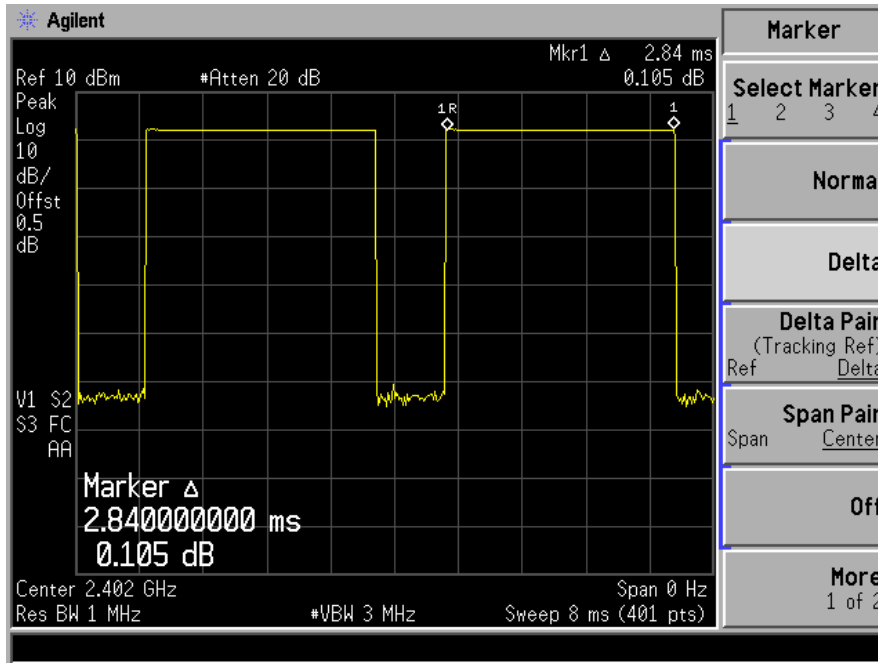

9.6 MAXIMUM PEAK CONDUCTED OUTPUT POWER

9.6.1 Applicable Standard

According to FCC Part 15.247(b)(1) and DA 00-705 / IC RSS-210.A8.4

9.6.2 Conformance Limit

The max For frequency hopping systems operating in the 2400-2483.5 MHz band employing at least 75 non-overlapping hopping channels: 1 watt. For all other frequency hopping systems in the 2400-2483.5 MHz band: 0.125 watts.

9.6.3 Test Configuration

Test according to clause 7.1 radio frequency test setup 1

9.6.4 Test Procedure

■ According to FCC Part 15.247(b)(1)

As an alternative to a peak power measurement, compliance with the limit can be based on a measurement of the maximum conducted output power.

Use the following spectrum analyzer settings:

Set Span = approximately 5 times the 20 dB bandwidth, centered on a hopping channel (about 10MHz)

Set RBW > the 20 dB bandwidth of the emission being measured (about 3MHz)

Set VBW ≥ RBW

Set Sweep = auto

Set Detector function = peak

Set Trace = max hold

Allow the trace to stabilize. Use the marker-to-peak function to set the marker to the peak of the emission to determine the peak amplitude level.

Set to the maximum power setting and enable the EUT transmit continuously.

Test Results

Temperature: 24°C Test Date: December 18, 2014
 Humidity: 53 % Test By: KK

Operation Mode	Channel Number	Channel Frequency (MHz)	Measurement Level (dBm)	Limit (dBm)	Verdict
GFSK	0	2402	2.340	30	PASS
	39	2441	2.821	30	PASS
	78	2480	3.630	30	PASS
π/4-DQPSK	0	2402	1.676	21	PASS
	39	2441	2.089	21	PASS
	78	2480	2.894	21	PASS
8DPSK	0	2402	1.770	21	PASS
	39	2441	2.233	21	PASS
	78	2480	3.015	21	PASS
Note: N/A					

Test Model	Maximum Peak Conducted Output Power
	GFSK
	Channel 0: 2402MHz

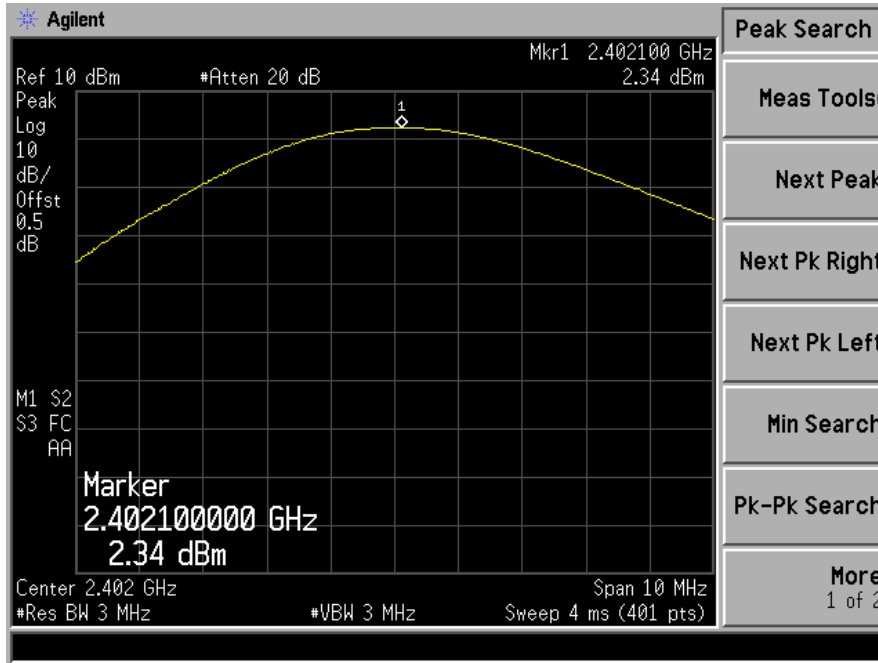

Test Model	Maximum Peak Conducted Output Power
	GFSK
	Channel 39: 2441MHz

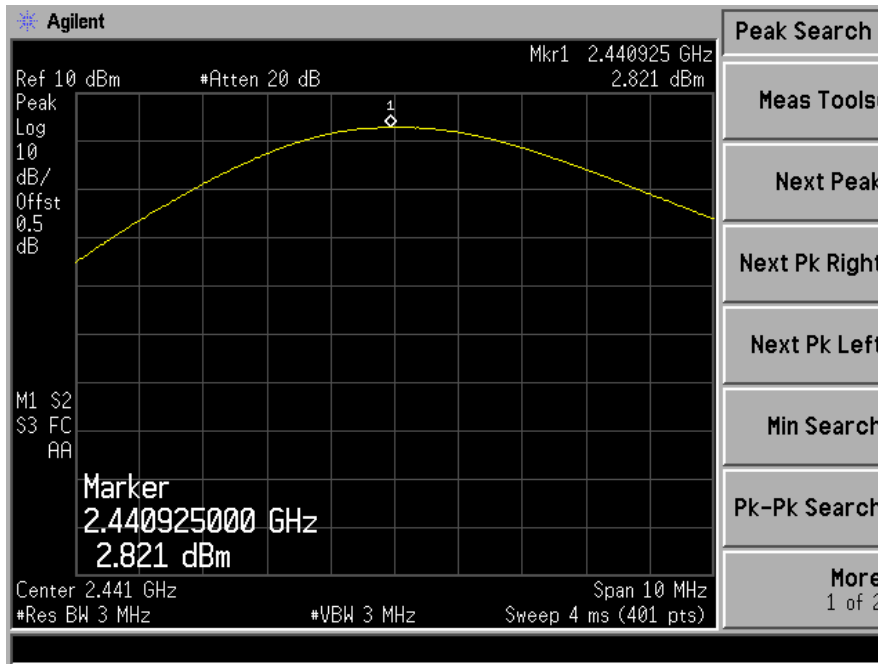

Test Model	Maximum Peak Conducted Output Power
	GFSK
	Channel 78: 2480MHz

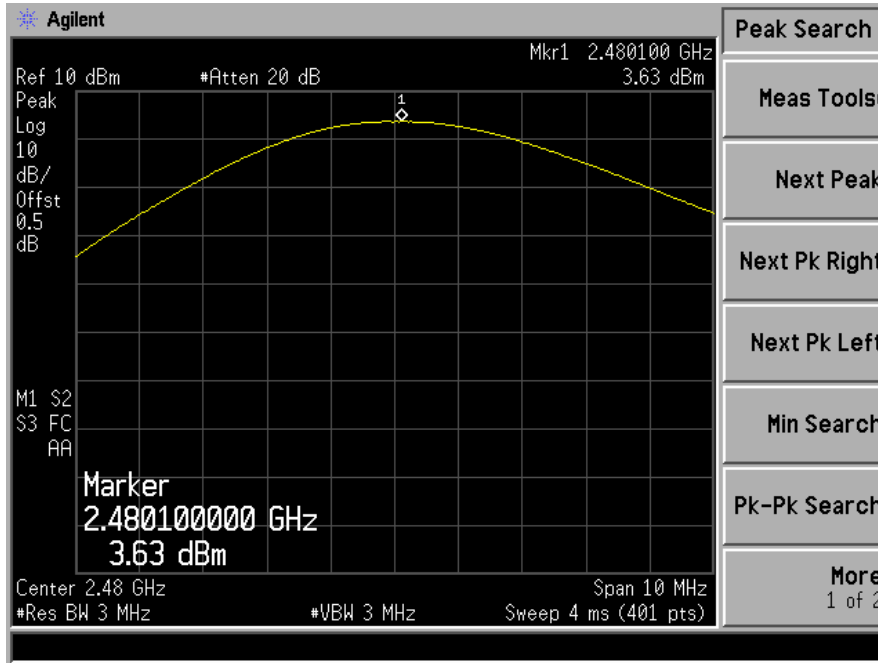

Test Model	Maximum Peak Conducted Output Power
	$\pi/4$ -DQPSK
	Channel 0: 2402MHz

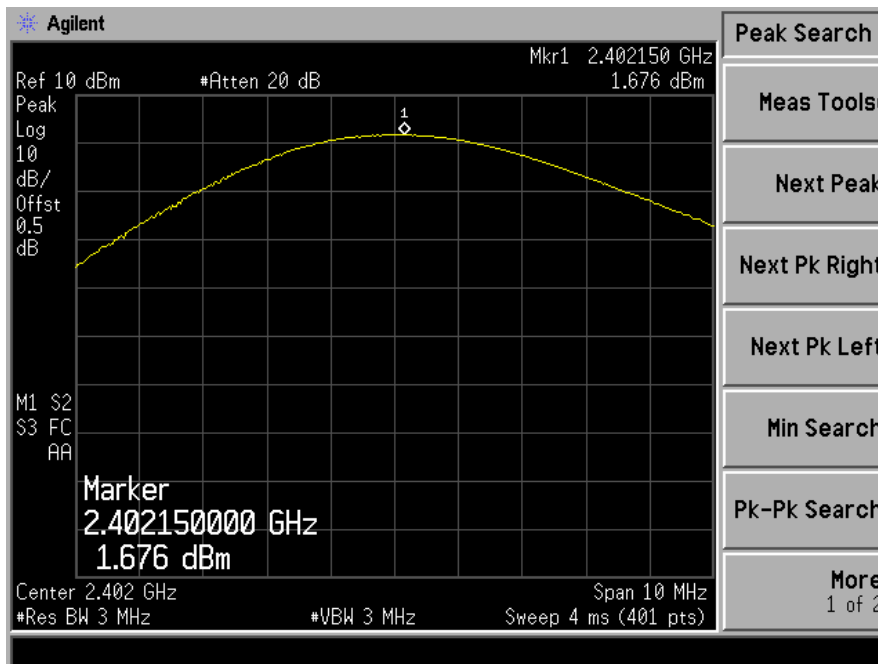

Test Model	Maximum Peak Conducted Output Power
	π /4-DQPSK
	Channel 39: 2441MHz

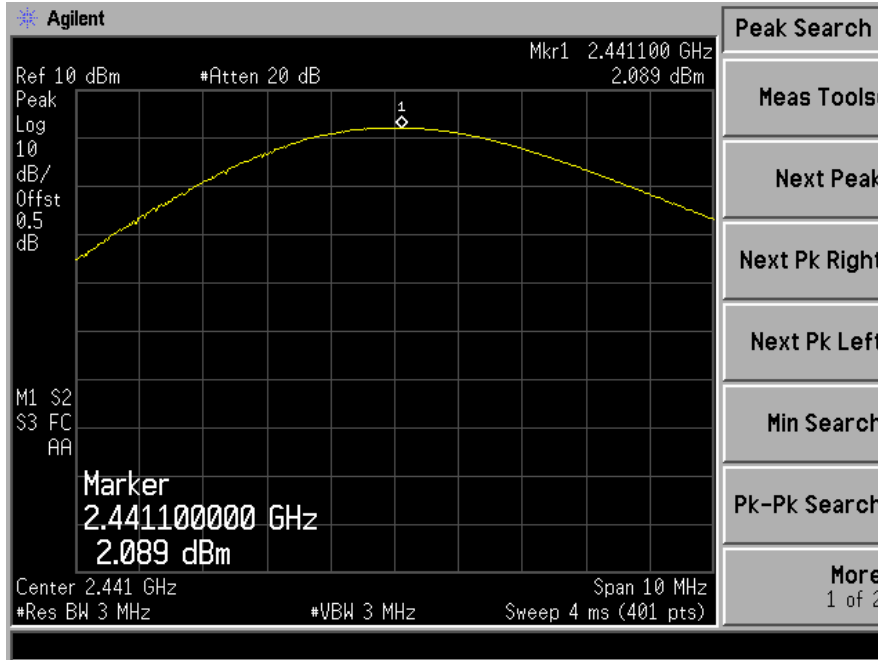

Test Model	Maximum Peak Conducted Output Power
	π /4-DQPSK
	Channel 78: 2480MHz

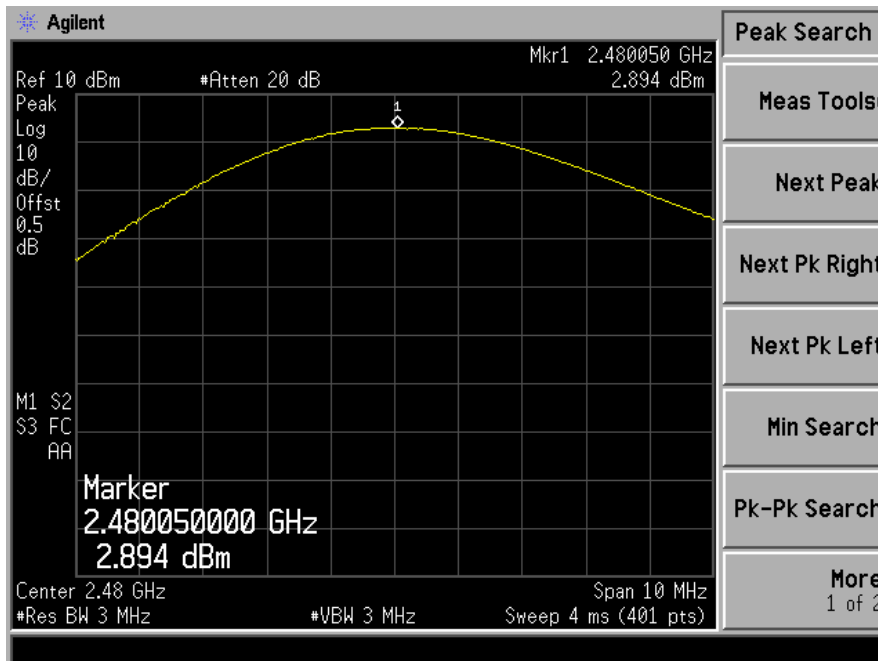

Test Model	Maximum Peak Conducted Output Power
	8DPSK
	Channel 0: 2402MHz

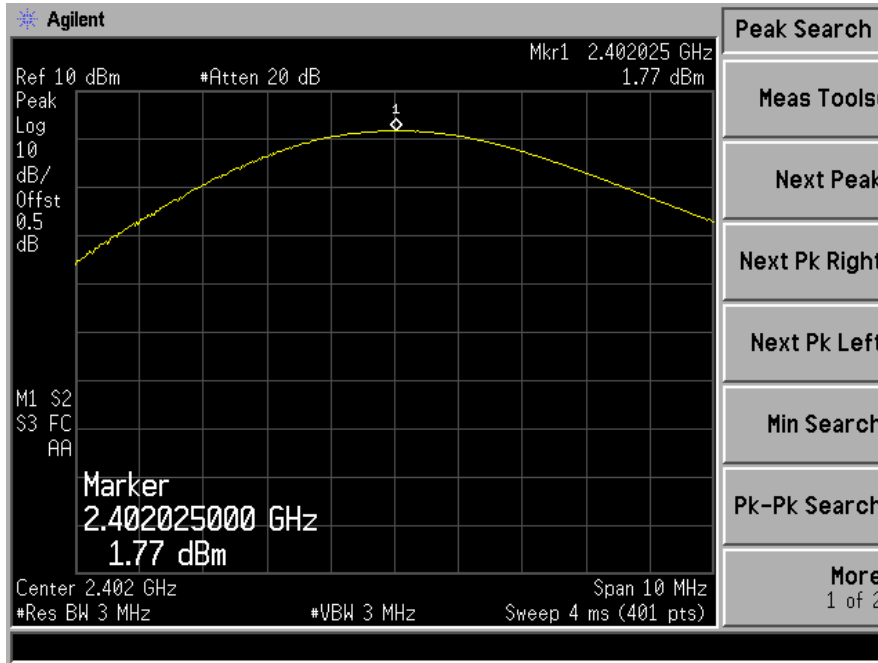

Test Model	Maximum Peak Conducted Output Power
	8DPSK
	Channel 39: 2441MHz

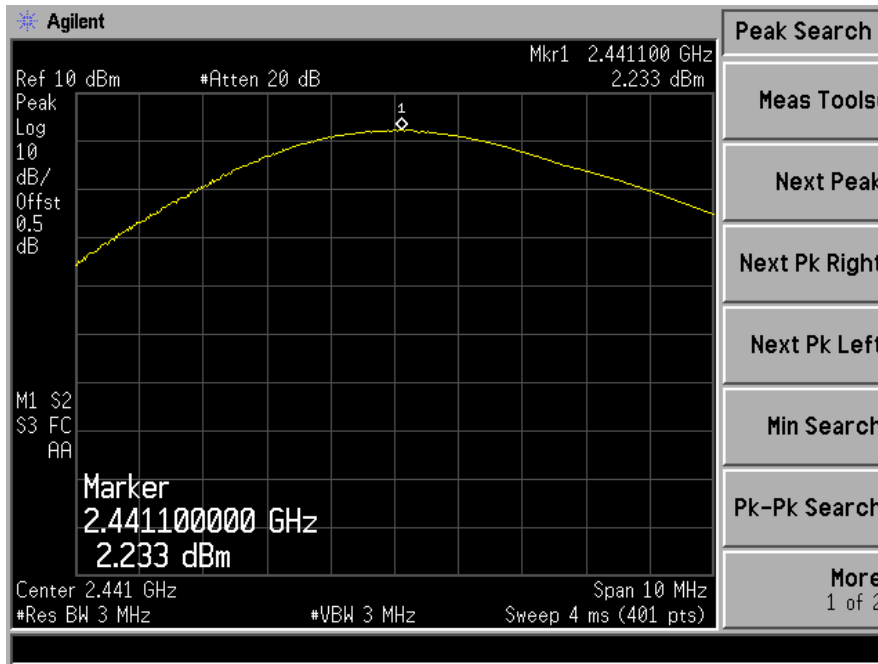

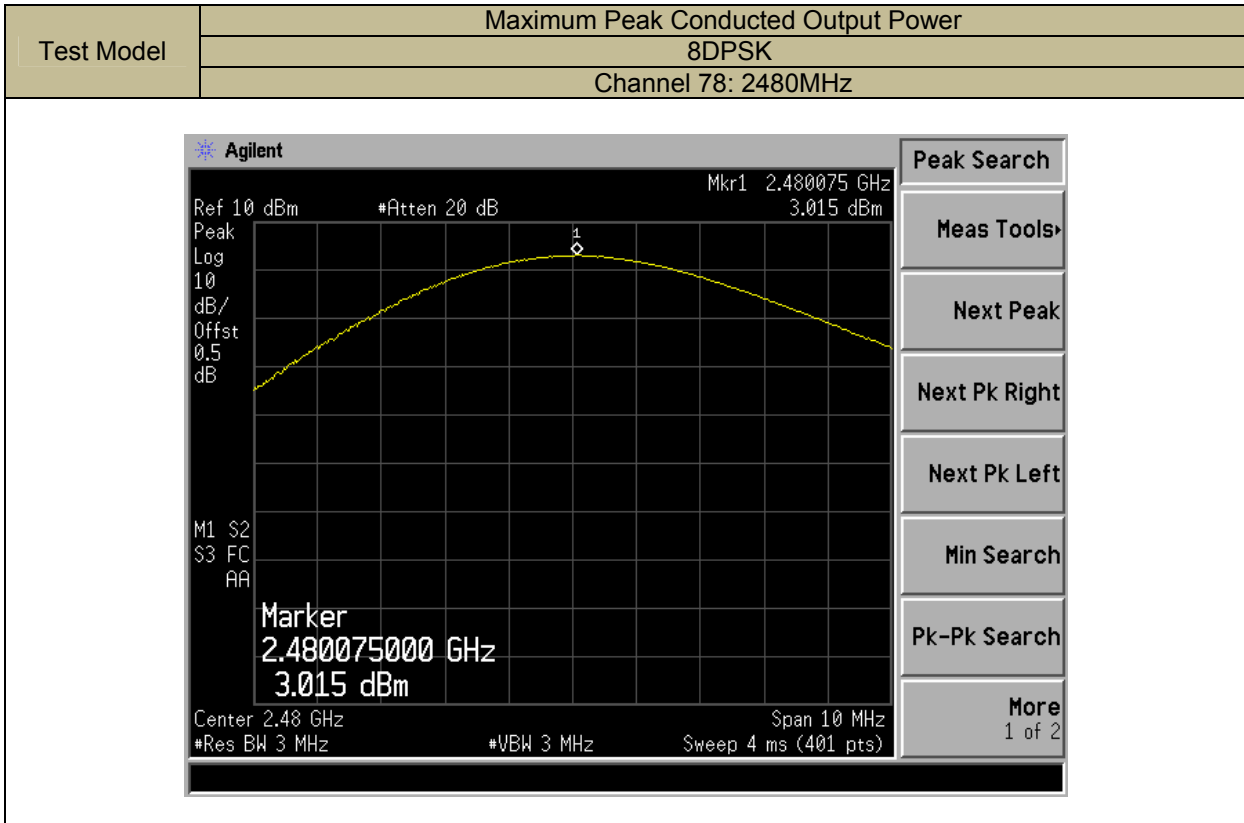

9.7 CONDUCTED SUPRIIOUS EMISSION

9.7.1 Applicable Standard

According to FCC Part 15.247(d) and DA 00-705 / IC RSS-210.A8.5

9.7.2 Conformance Limit

According to FCC Part 15.247(d):

In any 100 kHz bandwidth outside the frequency band in which the spread spectrum intentional radiator is operating, the radio frequency power that is produced by the intentional radiator shall be at least 20 dB below that in the 100 kHz bandwidth within the band that contains the highest level of the desired power, based on either an RF conducted, provided the transmitter demonstrates compliance with the peak conducted power limits.

9.7.3 Test Configuration

Test according to clause 7.1 radio frequency test setup 1

9.7.4 Test Procedure

The transmitter output (antenna port) was connected to the spectrum analyzer

■ Reference level measurement

Establish a reference level by using the following procedure:

Set instrument center frequency to DSS channel center frequency.

Set Span = approximately 5 times the 20 dB bandwidth, centered on a hopping channel.

Set the RBW = 100 kHz. Set the VBW $\geq 3 \times$ RBW.

Set Detector = peak. Set Sweep time = auto couple.

Set Trace mode = max hold. Allow trace to fully stabilize.

Use the peak marker function to determine the maximum Maximum conduceted level.

Note that the channel found to contain the maximum conduceted level can be used to establish the reference level.

■ Band-edge Compliance of RF Conducted Emissions

Use the following spectrum analyzer settings:

Span = wide enough to capture the peak level of the emission operating on the channel closest to the band-edge, as well as any modulation products which fall outside of the authorized band of operation

Set RBW $\geq 1\%$ of the span=100kHz Set VBW \geq RBW

Set Sweep = auto Set Detector function = peak Set Trace = max hold

Allow the trace to stabilize. Set the marker on the emission at the bandedge, or on the highest modulation product outside of the band, if this level is greater than that at the bandedge. Enable the marker-delta

function, then use the marker-to-peak function to move the marker to the peak of the in-band emission.

The marker-delta value now displayed must comply with the limit specified in this Section.

Now, using the same instrument settings, enable the hopping function of the EUT. Allow the trace to stabilize. Follow the same procedure listed above to determine if any spurious emissions caused by the hopping function also comply with the specified limit.

■ Conduceted Spurious RF Conducted Emission

Use the following spectrum analyzer settings:

Span = wide enough to capture the peak level of the in-band emission and all spurious emissions (e.g., harmonics) from the lowest frequency generated in the EUT up through the 10th harmonic.(30MHz to 25GHz). Set RBW = 100 kHz Set VBW \geq RBW

Set Sweep = auto Set Detector function = peak Set Trace = max hold

Set Sweep = auto Set Detector function = peak Set Trace = max hold

Allow the trace to stabilize. Set the marker on the peak of any spurious emission recorded. The level displayed must comply with the limit specified in this Section.

9.7.5 Test Results

Test Model	Conduceted Spurious RF Conducted Emission
	GFSK
	Channel 0: 2402MHz

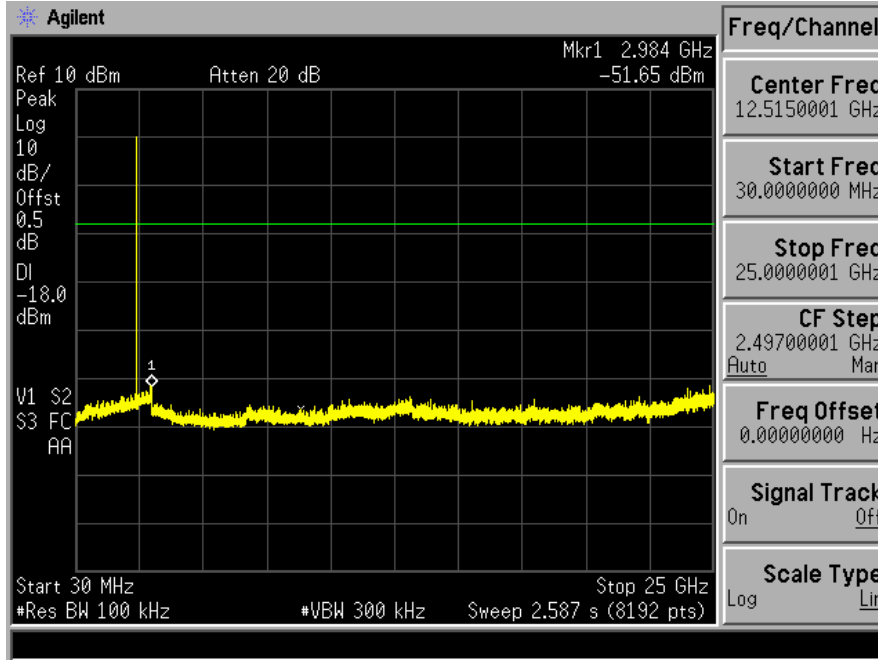

Test Model	Conduceted Spurious RF Conducted Emission
	GFSK
	Channel 39: 2441MHz

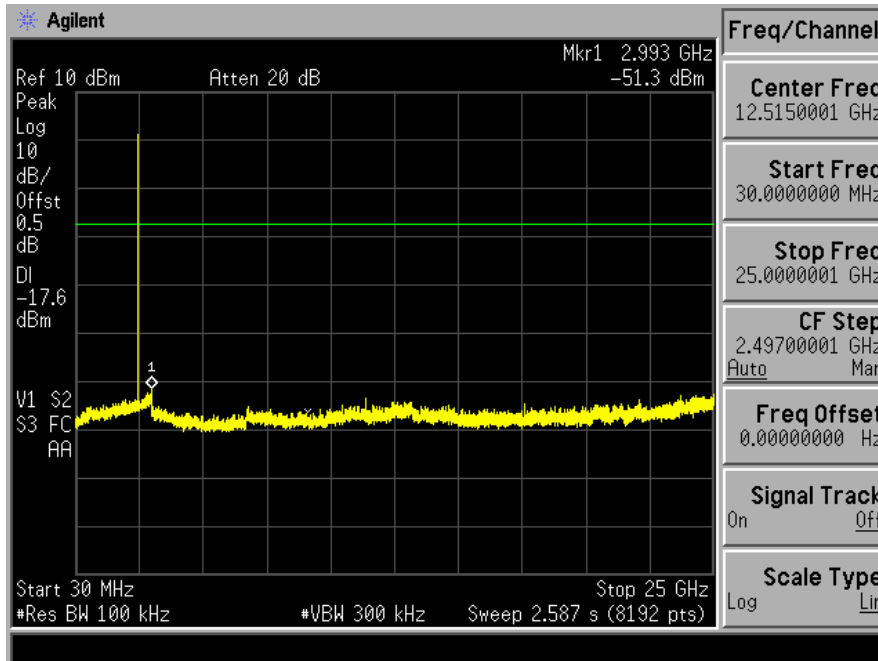

Test Model	Conduceted Spurious RF Conducted Emission
	GFSK
	Channel 78: 2480MHz

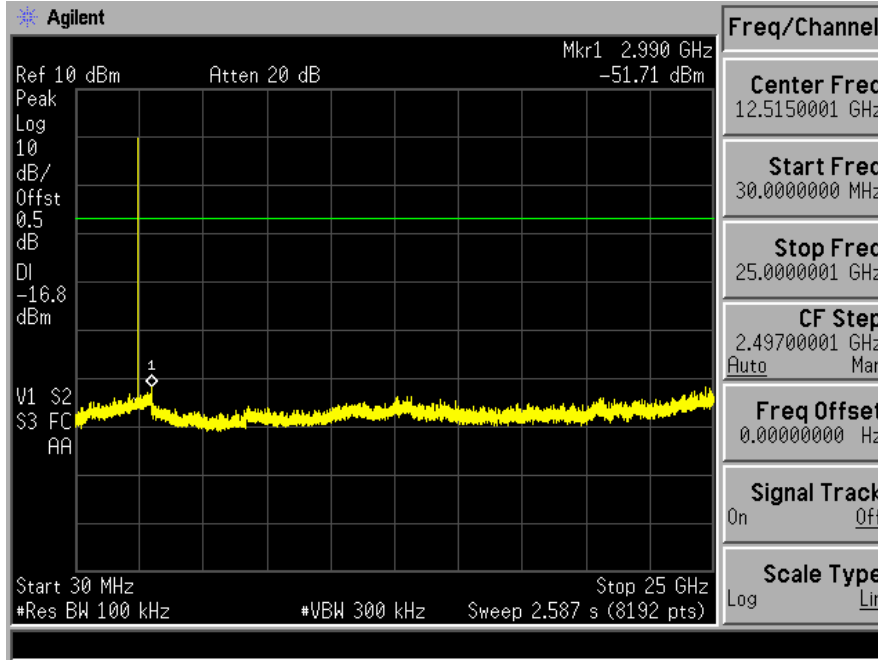

Test Model	Conduceted Spurious RF Conducted Emission
	$\pi/4$ -DQPSK
	Channel 0: 2402MHz

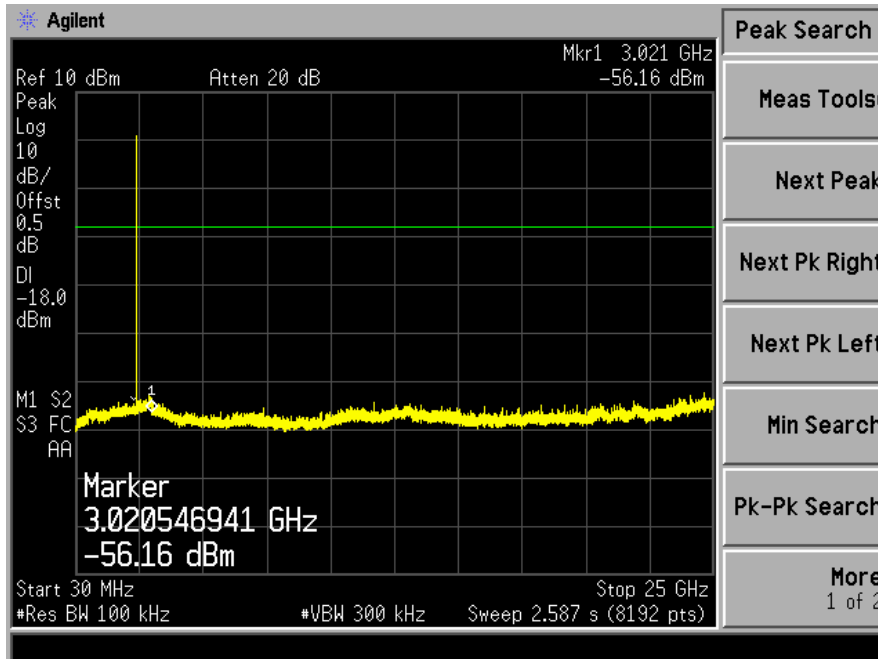

Test Model	Conduceted Spurious RF Conducted Emission
	π /4-DQPSK
	Channel 39: 2441MHz

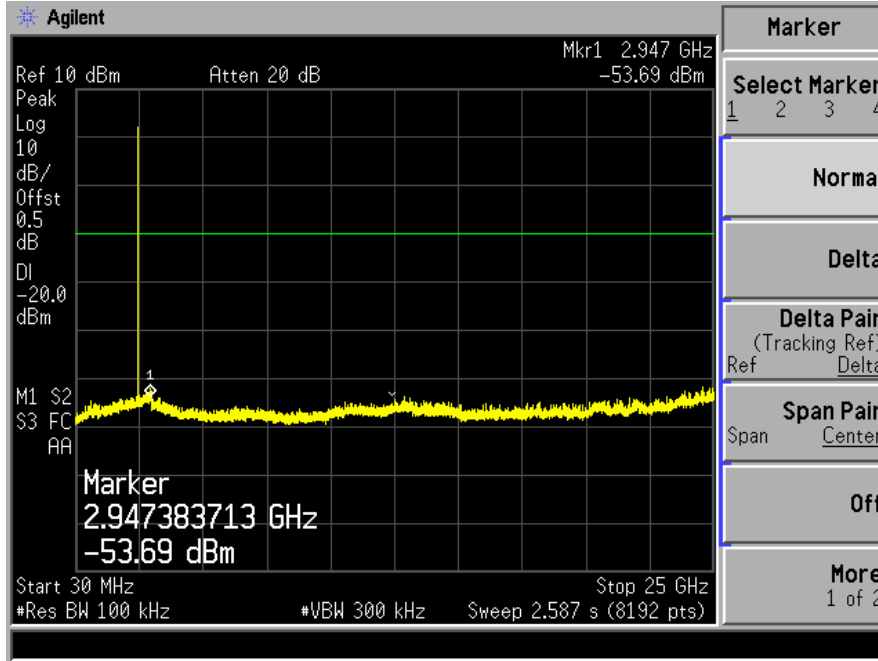

Test Model	Conduceted Spurious RF Conducted Emission
	π /4-DQPSK
	Channel 78: 2480MHz

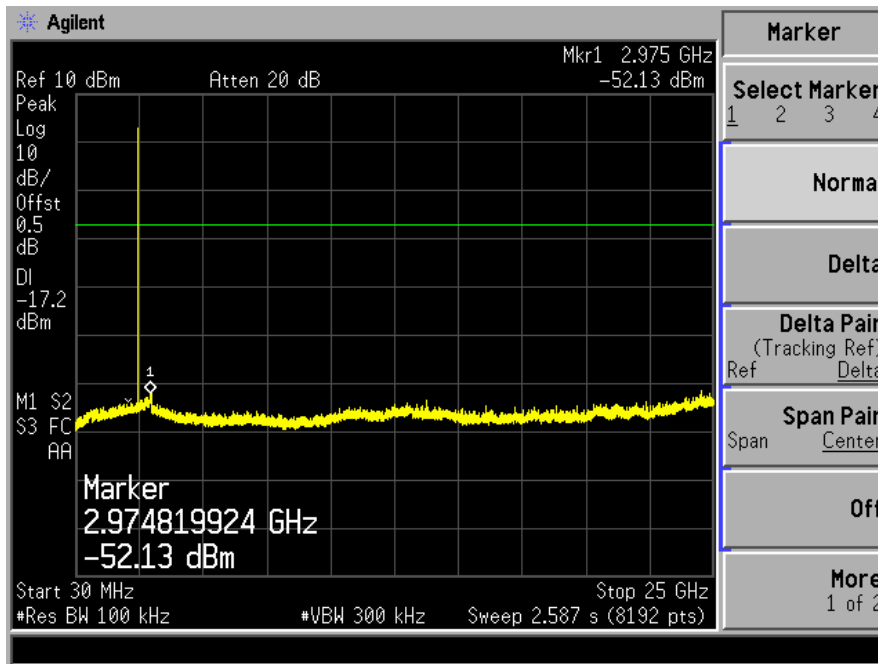

Test Model	Conduceted Spurious RF Conducted Emission
	8DPSK
	Channel 0: 2402MHz

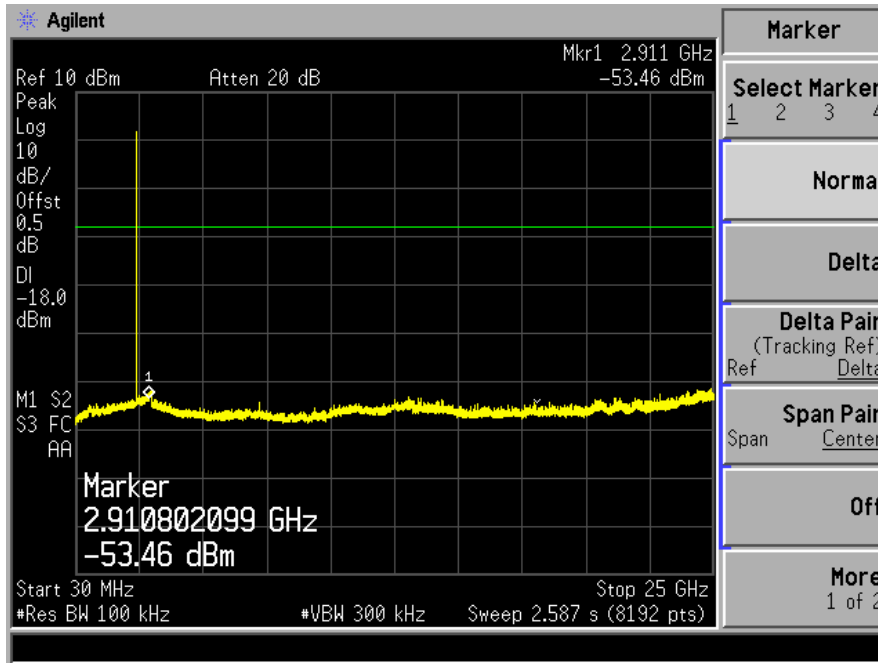

Test Model	Conduceted Spurious RF Conducted Emission
	8DPSK
	Channel 39: 2441MHz

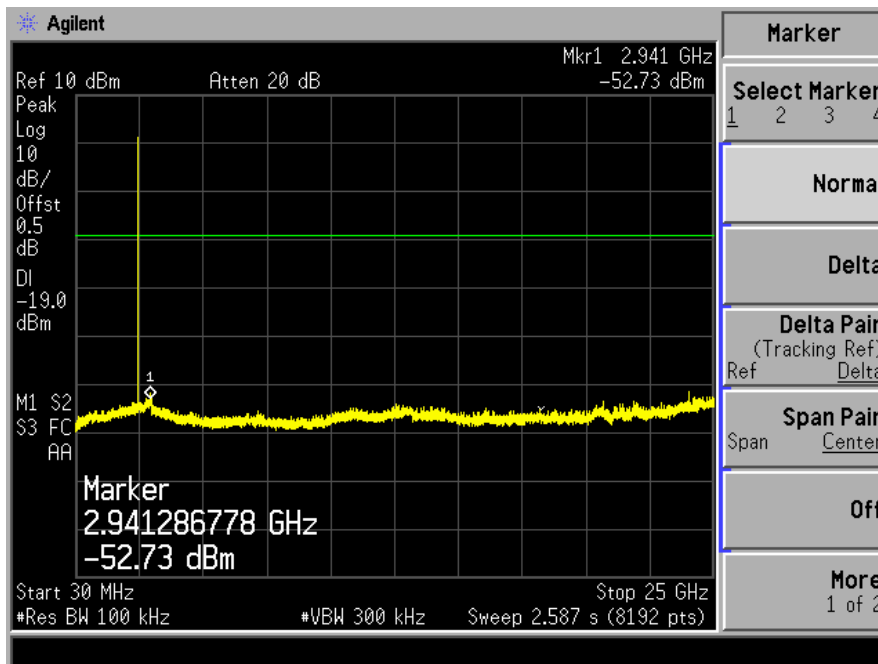

Test Model	Conduceted Spurious RF Conducted Emission
	8DPSK
	Channel 78: 2480MHz

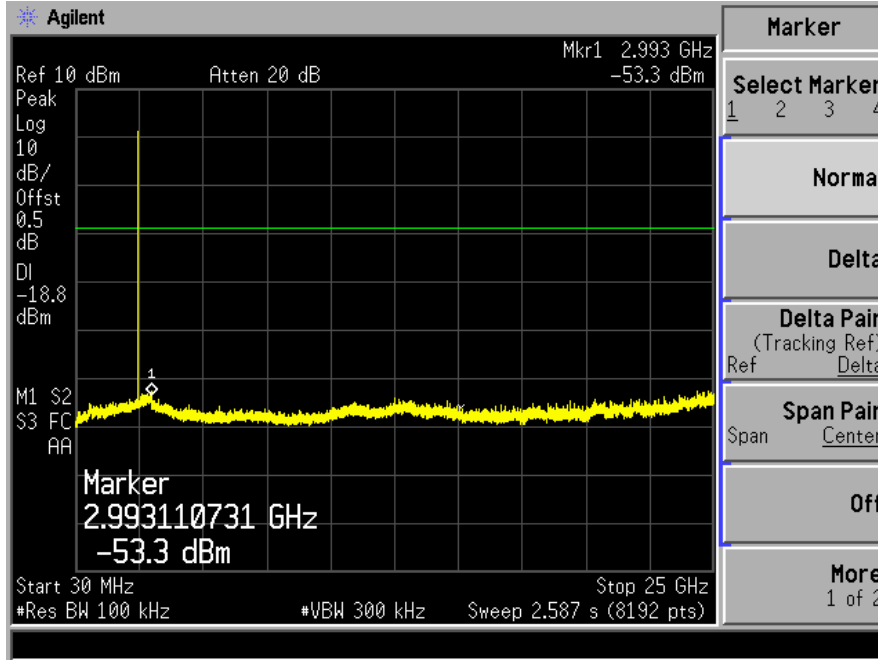

Test Model	Band-edge Conducted Emissions
	GFSK
	Channel 0: 2402MHz

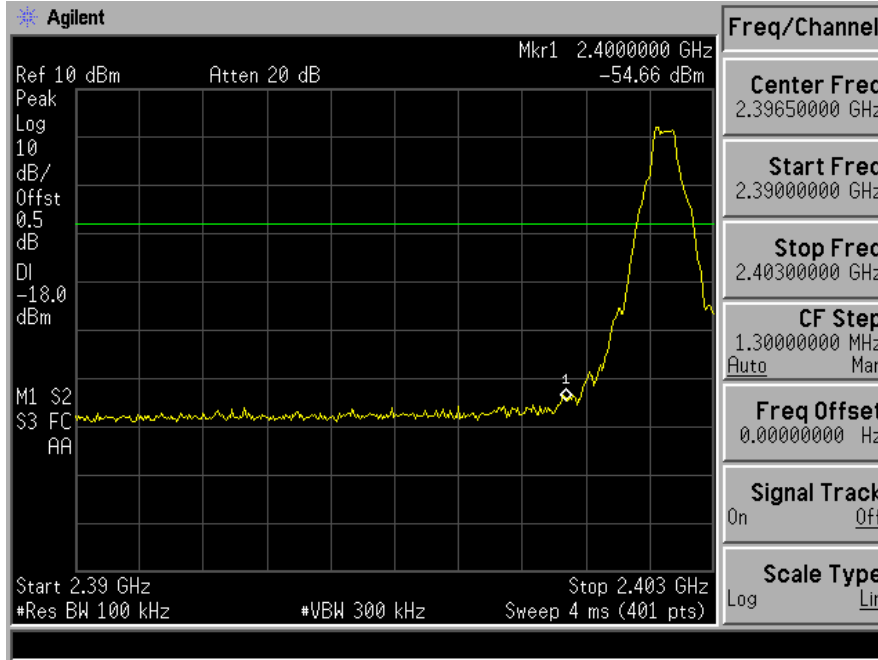

Test Model	Band-edge Conducted Emissions
	GFSK
	Hopping

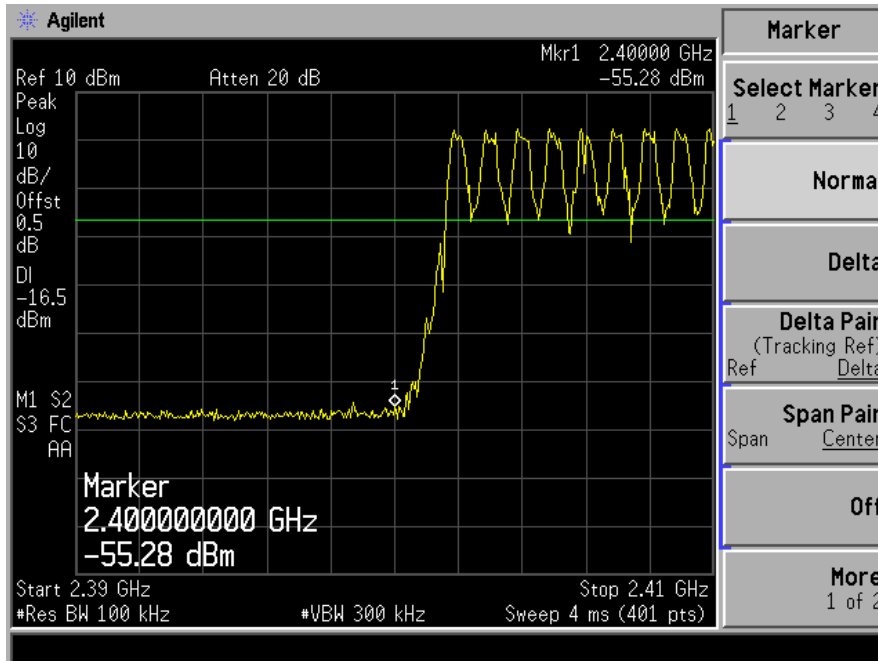

Test Model	Band-edge Conducted Emissions
	GFSK
	Channel 78: 2480MHz

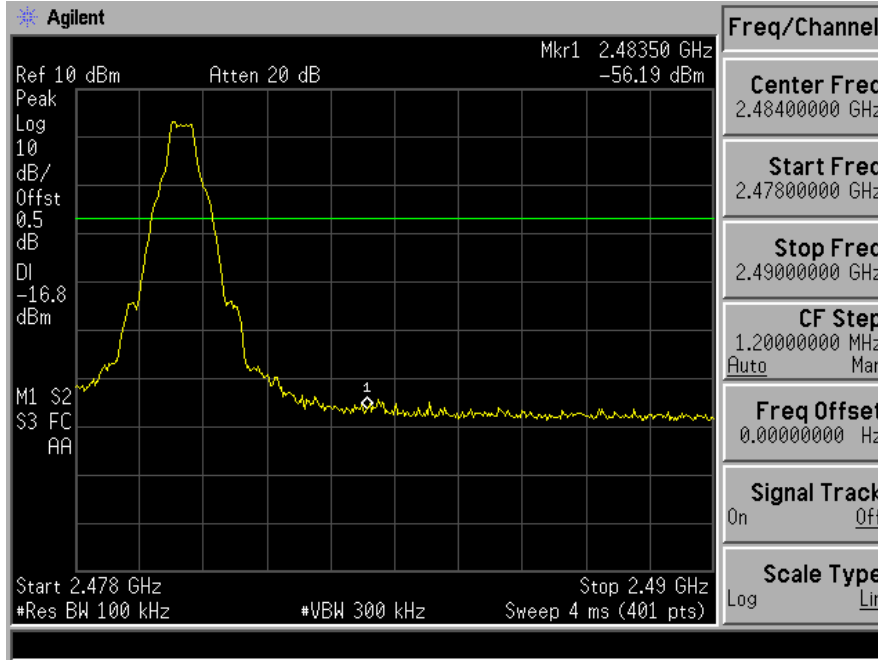

Test Model	Band-edge Conducted Emissions
	GFSK
	Hopping

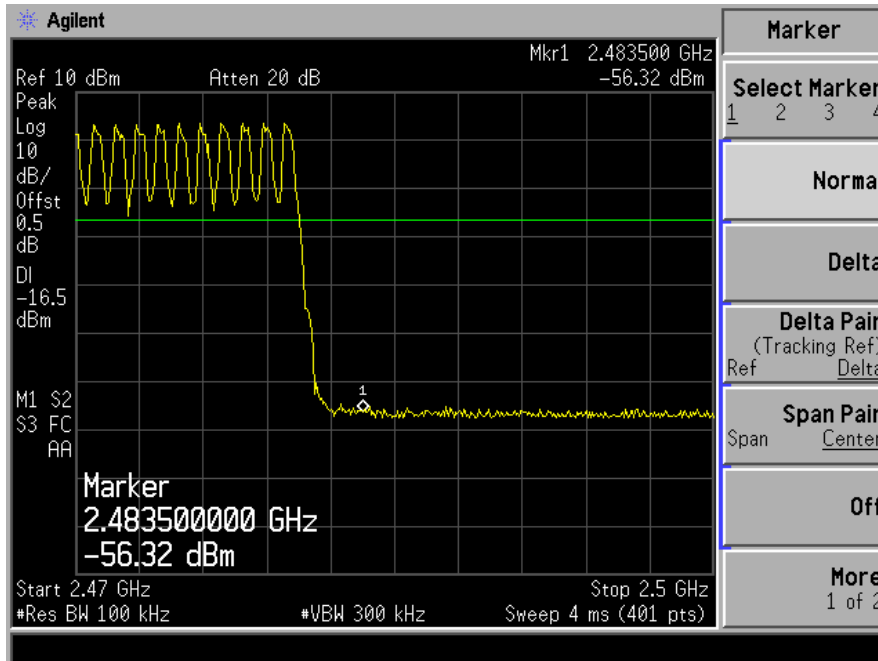

Test Model	Band-edge Conducted Emissions
	π /4-DQPSK
	Channel 0: 2402MHz

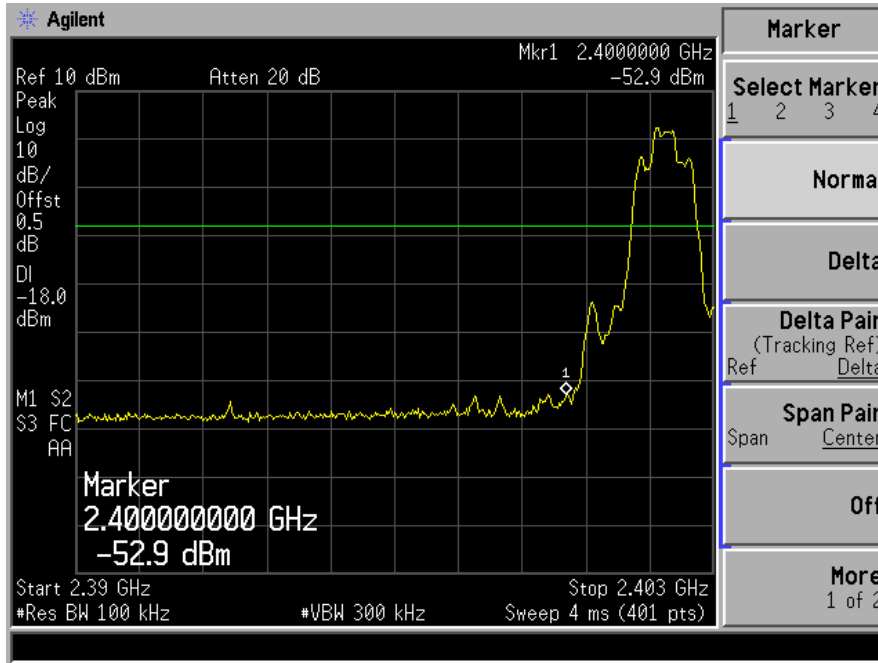

Test Model	Band-edge Conducted Emissions
	π /4-DQPSK
	Hopping

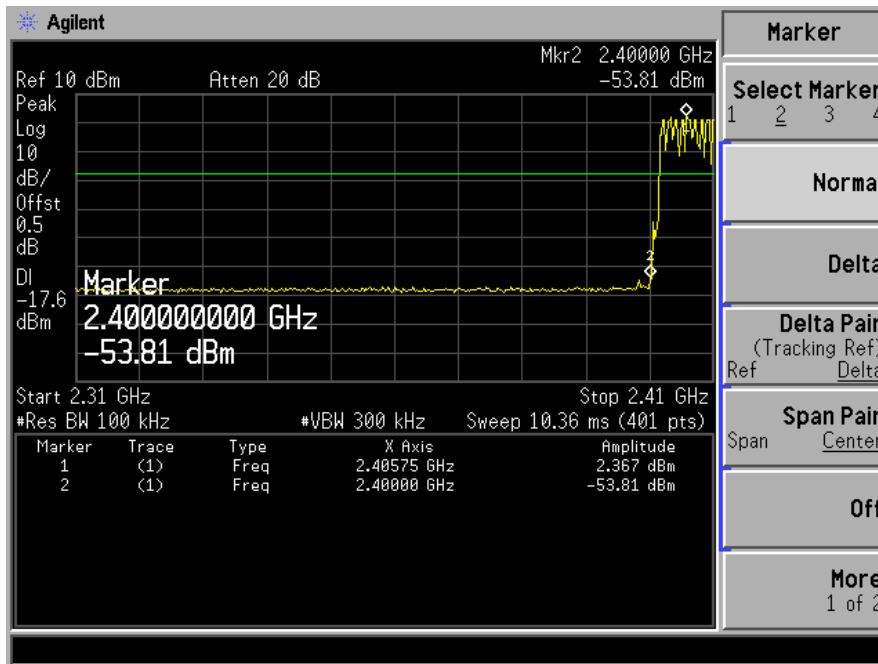

Test Model	Band-edge Conducted Emissions
	$\pi/4$ -DQPSK
	Channel 78: 2480MHz

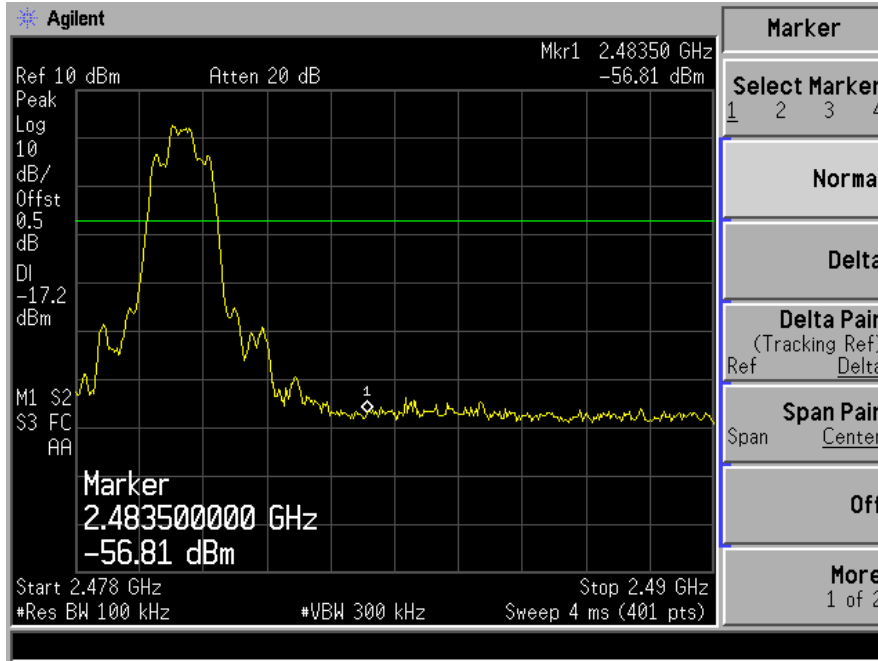

Test Model	Band-edge Conducted Emissions
	$\pi/4$ -DQPSK
	Hopping

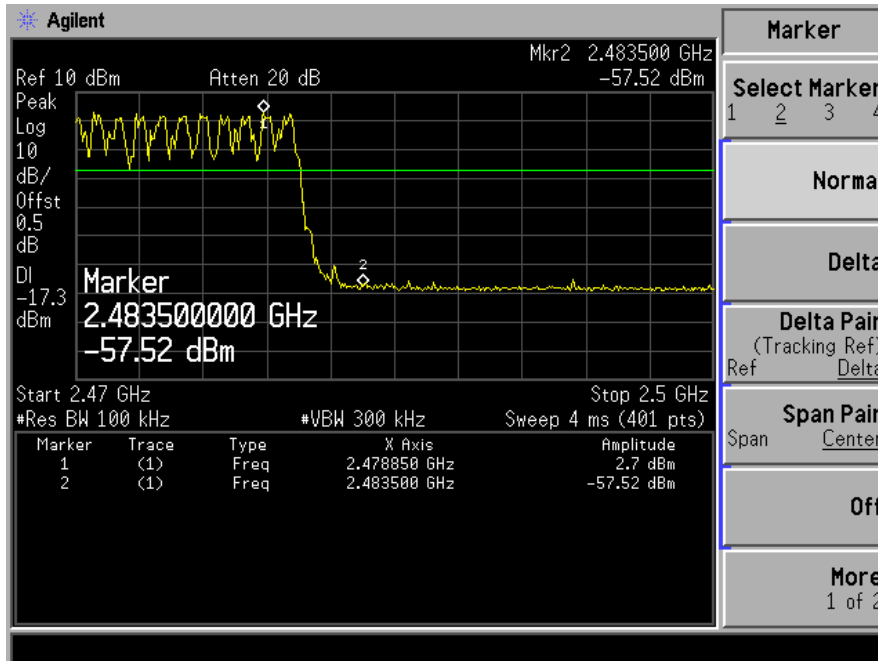

Test Model	Band-edge Conducted Emissions
	8DPSK
	Channel 0: 2402MHz

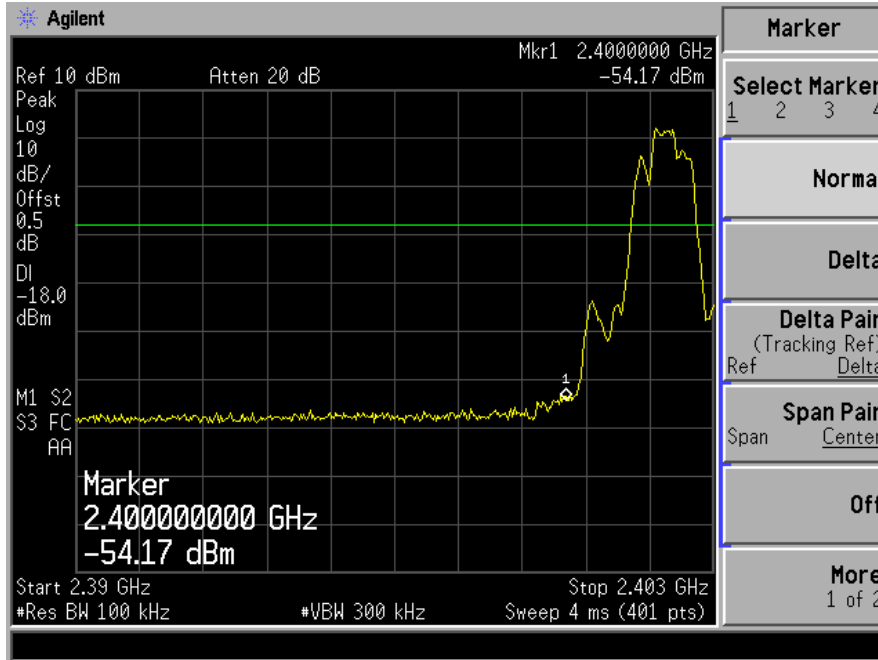

Test Model	Band-edge Conducted Emissions
	8DPSK
	Hopping

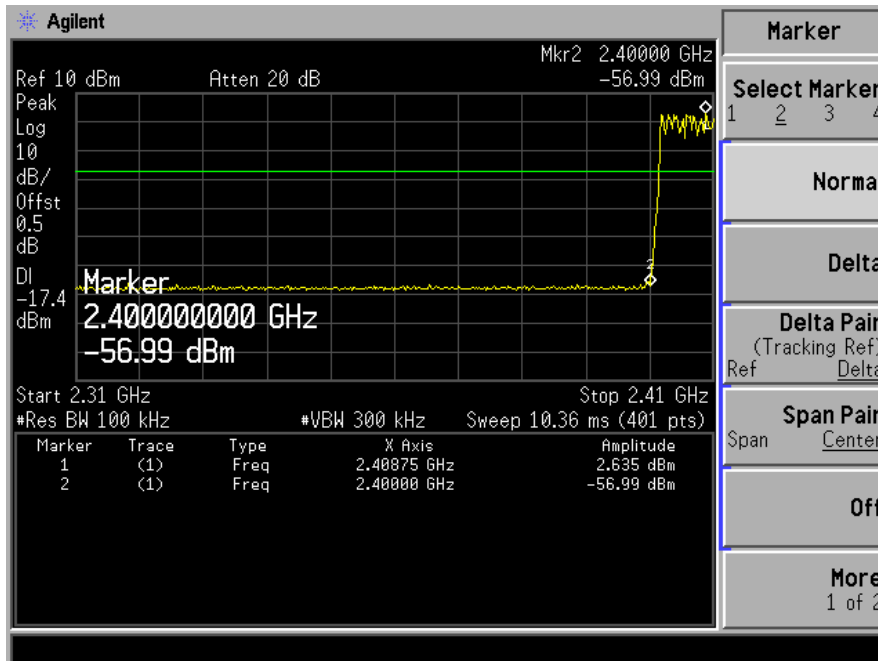

Test Model	Band-edge Conducted Emissions
	8DPSK
	Channel 78: 2480MHz

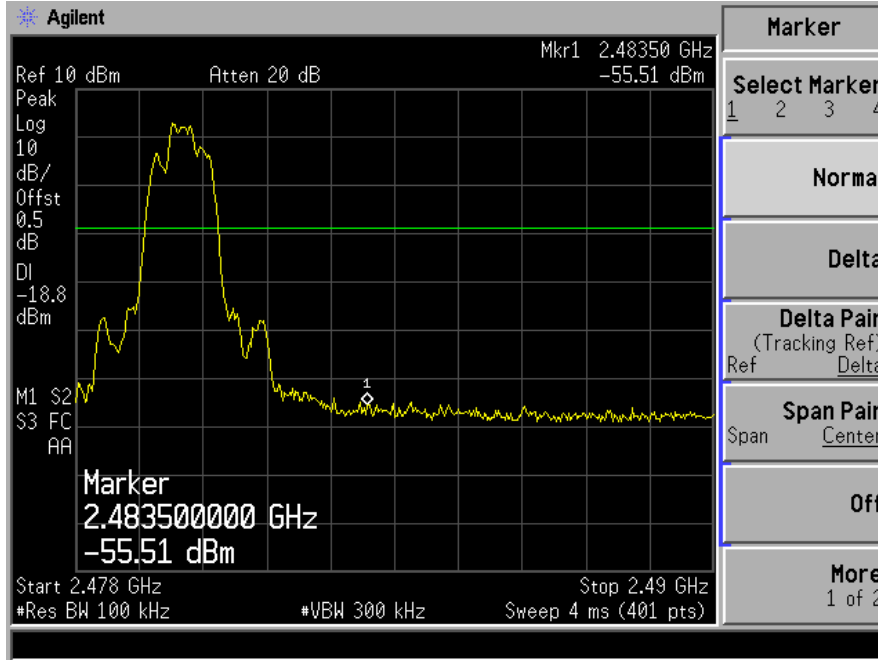

Test Model	Band-edge Conducted Emissions
	8DPSK
	Hopping

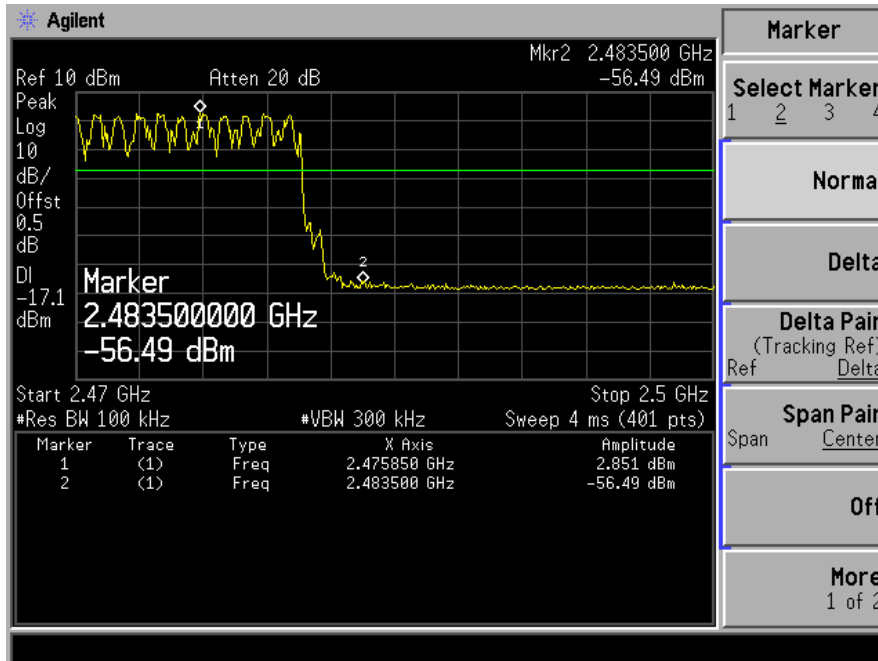

9.8 RADIATED SPURIOUS EMISSION

9.8.1 Applicable Standard

According to FCC Part 15.247(d) and 15.209 and DA 00-705 / IC RSS-210 A8.5, RSS-Gen 6.13, RSS-Gen 8.9 and RSS-Gen 8.10

9.8.2 Conformance Limit

According to FCC Part 15.247(d): radiated emissions which fall in the restricted bands, as defined in §15.205(a), must also comply with the radiated emission limits specified in §15.209(a) (see §15.205(c)).

According to FCC Part 15.205, Restricted bands

MHz	MHz	MHz	GHz
0.090-0.110	16.42-16.423	399.9-410	4.5-5.15
10.495-0.505	16.69475-16.69525	608-614	5.35-5.46
2.1735-2.1905	16.80425-16.80475	960-1240	7.25-7.75
4.125-4.128	25.5-25.67	1300-1427	8.025-8.5
4.17725-4.17775	37.5-38.25	1435-1626.5	9.0-9.2
4.20725-4.20775	73-74.6	1645.5-1646.5	9.3-9.5
6.215-6.218	74.8-75.2	1660-1710	10.6-12.7
6.26775-6.26825	123-138	2200-2300	14.47-14.5
8.291-8.294	149.9-150.05	2310-2390	15.35-16.2
8.362-8.366	156.52475-156.52525	2483.5-2500	17.7-21.4
8.37625-8.38675	156.7-156.9	2690-2900	22.01-23.12
8.41425-8.41475	162.0125-167.17	3260-3267	23.6-24.0
12.29-12.293	167.72-173.2	3332-3339	31.2-31.8
12.51975-12.52025	240-285	3345.8-3358	36.43-36.5
12.57675-12.57725	322-335.4	3600-4400	(2)
13.36-13.41			

According to FCC Part 15.205, the level of any transmitter spurious emission in Restricted bands shall not exceed the level of the emission specified in the following table

Restricted Frequency(MHz)	Field Strength ($\mu\text{V}/\text{m}$)	Field Strength ($\text{dB}\mu\text{V}/\text{m}$)	Measurement Distance
0.009~0.490	2400/F(KHz)	20 log ($\mu\text{V}/\text{m}$)	300
0.490~1.705	2400/F(KHz)	20 log ($\mu\text{V}/\text{m}$)	30
1.705~30.0	30	29.5	30
30-88	100	40	3
88-216	150	43.5	3
216-960	200	46	3
Above 960	500	54	3

Remark :1. Emission level in $\text{dB}\mu\text{V}/\text{m}=20 \log (\mu\text{V}/\text{m})$

2. Measurement was performed at an antenna to the closed point of EUT distance of meters.

3. Distance extrapolation factor $=40 \log (\text{Specific distance}/ \text{test distance})(\text{dB})$;

Limit line=Specific limits($\text{dB}\mu\text{V}$) + distance extrapolation factor.

for the frequency ranges below 30 MHz, a narrower RBW is used for these ranges but the measured value should add a RBW correction factor (RBWCF) where $\text{RBWCF} [\text{dB}] = 10 \cdot \lg(100 [\text{kHz}]/\text{narrower RBW} [\text{kHz}])$. , the narrower RBW is 1 kHz and RBWCF is 20 dB for the frequency 9 kHz to 150 kHz, and the narrower RBW is 10 kHz and RBWCF is 10 dB for the frequency 150 kHz to 30 MHz.

9.8.3 Test Configuration

Test according to clause 7.2 radio frequency test setup 2

9.8.4 Test Procedure

This test is required for any spurious emission that falls in a Restricted Band, as defined in Section 15.205. It must be performed with the highest gain of each type of antenna proposed for use with the EUT. Use the following spectrum analyzer settings:

For Above 1GHz(IC):

The EUT was placed on a turn table which is 1.5m above ground plane.

Maximum procedure was performed on the highest emissions to ensure EUT compliance.

Span = wide enough to fully capture the emission being measured

RBW = 1 MHz

VBW ≥ RBW for peak measurement

VBW = 10Hz for Average measurement

Sweep = auto

Detector function = peak

Trace = max hold

For Above 1GHz(FCC):

The EUT was placed on a turn table which is 1.5m above ground plane.

Maximum procedure was performed on the highest emissions to ensure EUT compliance.

Span = wide enough to fully capture the emission being measured

RBW = 1 MHz

VBW ≥ RBW for peak measurement

VBW = 10Hz for Average measurement

Sweep = auto

Detector function = peak

Trace = max hold

For Below 1GHz:

The EUT was placed on a turn table which is 0.8m above ground plane.

Maximum procedure was performed on the highest emissions to ensure EUT compliance.

Span = wide enough to fully capture the emission being measured

RBW = 100 kHz for

VBW ≥ RBW

Sweep = auto

Detector function = peak

Trace = max hold

Follow the guidelines in ANSI C63.4-1992 with respect to maximizing the emission by rotating the EUT, measuring the emission while the EUT is situated in three orthogonal planes (if appropriate), adjusting the measurement antenna height and polarization, etc. A pre-amp and a high pass filter are required for this test, in order to provide the measuring system with sufficient sensitivity. Allow the trace to stabilize. The peak reading of the emission, after being corrected by the antenna factor, cable loss, pre-amp gain, etc., is the peak field strength, which must comply with the limit specified in Section 15.35(b). Submit this data.

Now set the VBW to 10 Hz, while maintaining all of the other instrument settings. This peak level, once corrected, must comply with the limit specified in Section 15.209. If the dwell time per channel of the hopping signal is less than 100 ms, then the reading obtained with the 10 Hz VBW may be further adjusted by a “duty cycle correction factor”, derived from $20\log(\text{dwell time}/100 \text{ ms})$, in an effort to demonstrate compliance with the 15.209 limit. Submit this data.

Repeat above procedures until all frequency measured was complete.

9.8.5 Test Results

■ Spurious Emission below 30MHz (9KHz to 30MHz)

Freq. (MHz)	Ant.Pol. H/V	Emission Level(dBuV/m)		Limit 3m(dBuV/m)		Over(dB)	
		PK	AV	PK	AV	PK	AV
--	--	--	--	--	--	--	--

■ Spurious Emission Below 1GHz (30MHz to GHz)

Bluetooth (GFSK, π/4-DQPSK, 8DPSK) mode have been tested, and the worst result was report as below:

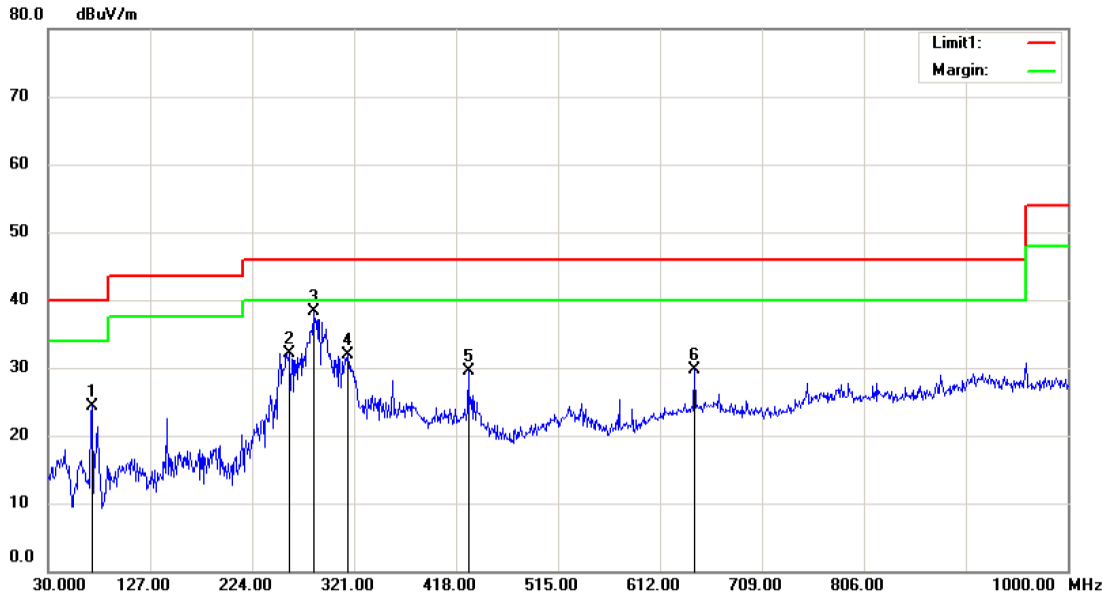

Site 3m Chamber #1 Polarization: *Horizontal* Temperature: 24 C
 Limit: (RE)FCC PART 15 CLASS B Power: AC 120V/60Hz Humidity: 53 %
 Mode:BT 2402
 Note:

No.	Mk.	Freq.	Reading Level	Correct Factor	Measurement	Limit	Over	Antenna Height	Table Degree	
		MHz	dBuV	dB	dBuV/m	dBuV/m	dB	cm	degree	Comment
1		71.7100	42.61	-18.38	24.23	40.00	-15.77			QP
2		258.9200	43.60	-11.44	32.16	46.00	-13.84			QP
3	*	282.2000	49.20	-10.88	38.32	46.00	-7.68			QP
4		315.1800	43.49	-11.60	31.89	46.00	-14.11			QP
5		429.6400	38.33	-8.90	29.43	46.00	-16.57			QP
6		644.9800	34.70	-5.06	29.64	46.00	-16.36			QP

*:Maximum data x:Over limit !:over margin

Operator: KK

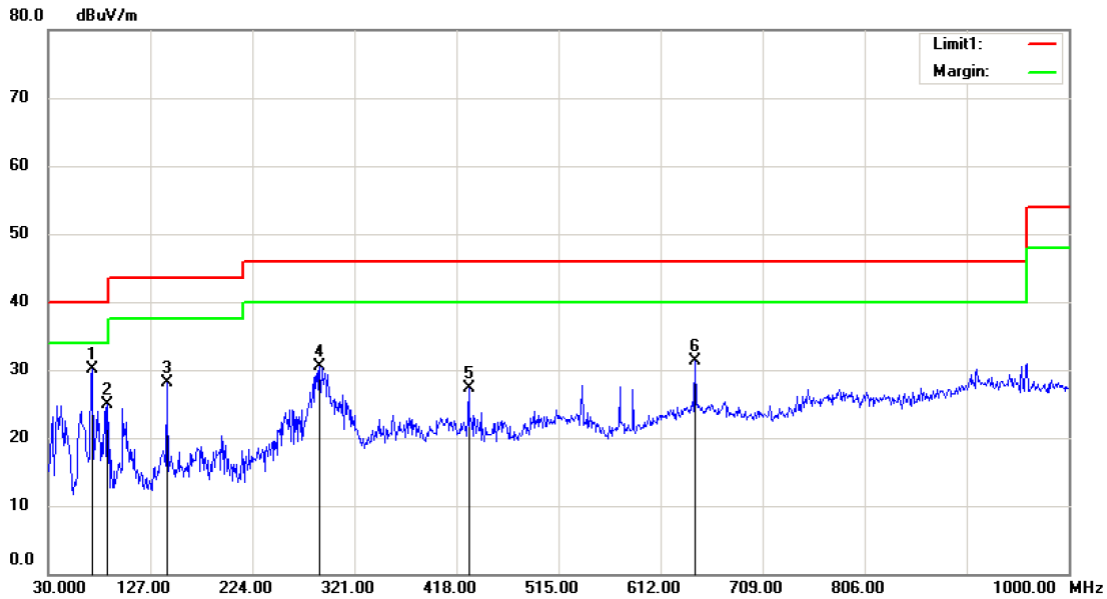

Site 3m Chamber #1 Polarization: **Vertical** Temperature: 24 C
 Limit: (RE)FCC PART 15 CLASS B Power: AC 120V/60Hz Humidity: 53 %
 Mode:BT 2402
 Note:

No.	Mk.	Freq. MHz	Reading Level dBuV	Correct Factor dB	Measure- ment dBuV/m	Limit dBuV/m	Over dB	Antenna Height cm	Table Degree degree	Comment
1	*	71.7100	48.46	-18.38	30.08	40.00	-9.92	QP		
2		86.2600	42.10	-17.29	24.81	40.00	-15.19	QP		
3		142.5200	45.19	-17.14	28.05	43.50	-15.45	QP		
4		288.0200	41.40	-10.90	30.50	46.00	-15.50	QP		
5		429.6400	36.25	-8.90	27.35	46.00	-18.65	QP		
6		644.9800	36.40	-5.06	31.34	46.00	-14.66	QP		

*:Maximum data x:Over limit !:over margin

Operator: KK

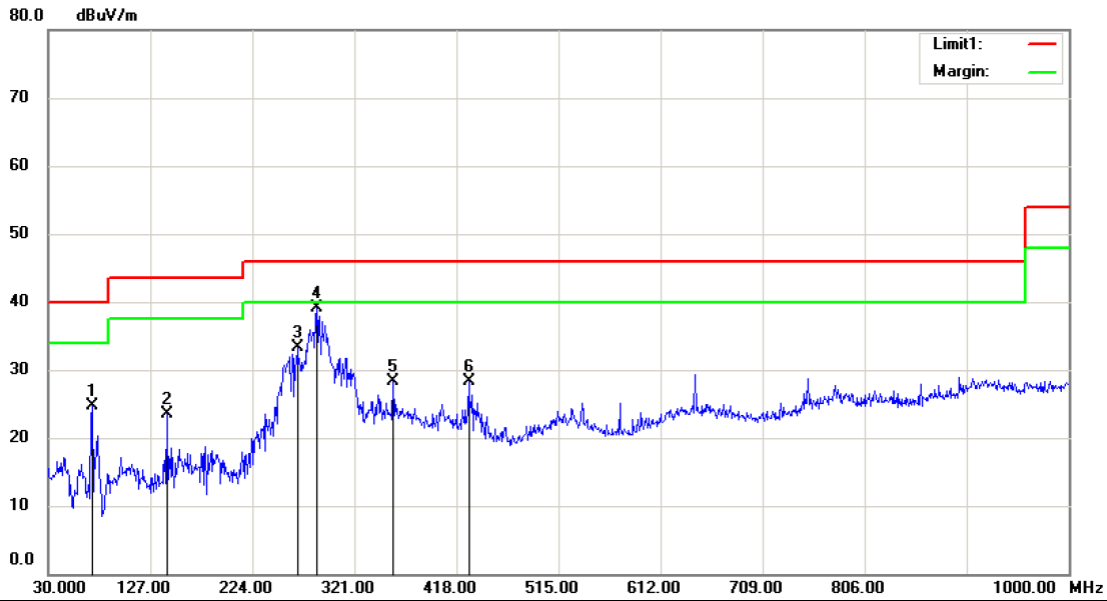

Site 3m Chamber #1 Polarization: **Horizontal** Temperature: 24 C
 Limit: (RE)FCC PART 15 CLASS B Power: AC 120V/60Hz Humidity: 53 %
 Mode:BT 2441
 Note:

No.	Mk.	Freq.	Reading Level	Correct Factor	Measurement	Limit	Over	Antenna Height	Table Degree	
		MHz	dBuV	dB	dBuV/m	dBuV/m	dB	cm	degree	Comment
1		71.7100	43.01	-18.38	24.63	40.00	-15.37	QP		
2		142.5200	40.55	-17.14	23.41	43.50	-20.09	QP		
3		266.6800	44.44	-11.17	33.27	46.00	-12.73	QP		
4	*	285.1100	49.92	-10.91	39.01	46.00	-6.99	QP		
5		357.8600	37.73	-9.44	28.29	46.00	-17.71	QP		
6		429.6400	37.13	-8.90	28.23	46.00	-17.77	QP		

*:Maximum data x:Over limit !:over margin

Operator: KK

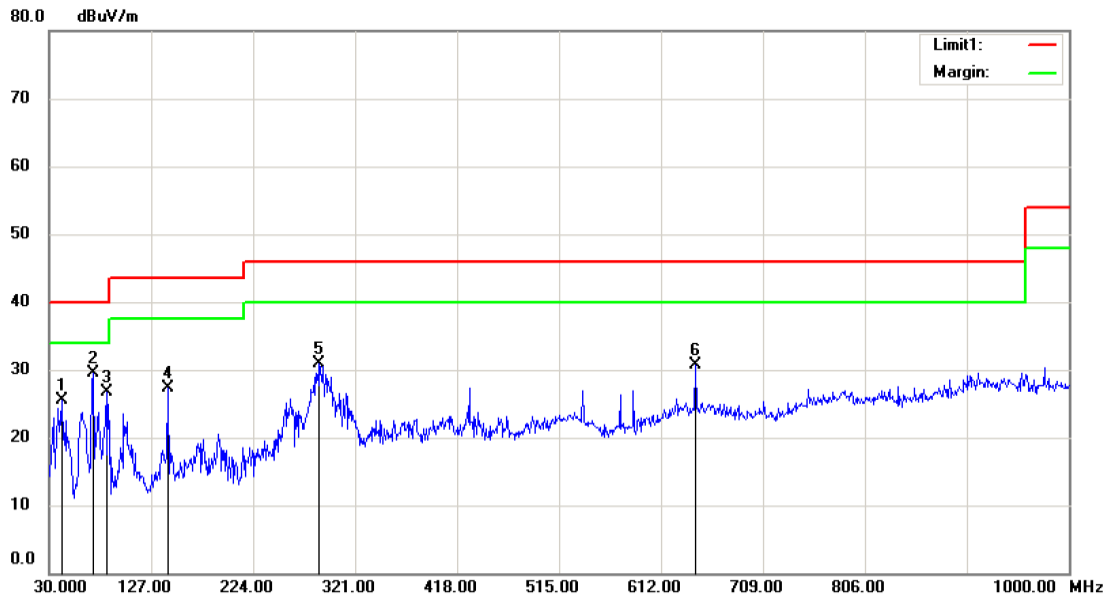

Site 3m Chamber #1 Polarization: *Vertical* Temperature: 24 C
 Limit: (RE)FCC PART 15 CLASS B Power: AC 120V/60Hz Humidity: 53 %
 Mode:BT 2441
 Note:

No.	Mk.	Freq.	Reading Level	Correct Factor	Measurement	Limit	Over	Antenna Height	Table Degree	
		MHz	dBuV	dB	dBuV/m	dBuV/m	dB	cm	degree	Comment
1		41.6400	37.39	-11.84	25.55	40.00	-14.45			QP
2	*	71.7100	47.97	-18.38	29.59	40.00	-10.41			QP
3		84.3200	44.64	-17.88	26.76	40.00	-13.24			QP
4		142.5200	44.45	-17.14	27.31	43.50	-16.19			QP
5		287.0500	41.76	-10.90	30.86	46.00	-15.14			QP
6		644.9800	35.69	-5.06	30.63	46.00	-15.37			QP

*:Maximum data x:Over limit !:over margin

Operator: KK

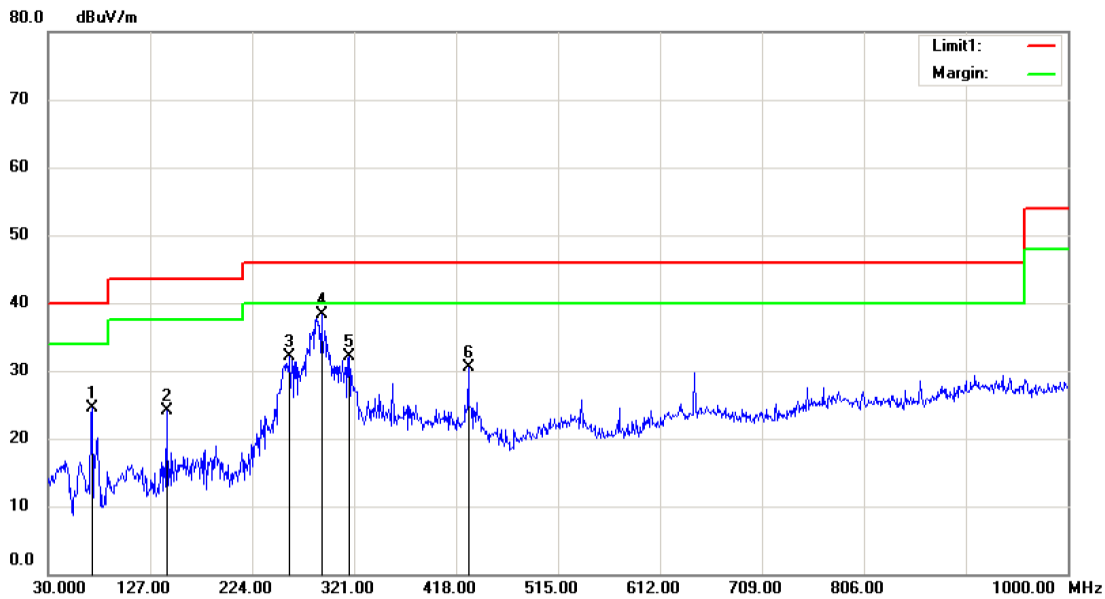

Site 3m Chamber #1 Polarization: *Horizontal* Temperature: 24 C
 Limit: (RE)FCC PART 15 CLASS B Power: AC 120V/60Hz Humidity: 53 %
 Mode:BT 2480
 Note:

No.	Mk.	Freq. MHz	Reading Level dBuV	Correct Factor dB	Measure- ment dBuV/m	Limit dBuV/m	Over dB	Antenna Height cm	Table Degree	Detector	Comment
1		71.7100	42.92	-18.38	24.54	40.00	-15.46			QP	
2		142.5200	41.34	-17.14	24.20	43.50	-19.30			QP	
3		259.8900	43.38	-11.33	32.05	46.00	-13.95			QP	
4	*	289.9600	49.26	-10.88	38.38	46.00	-7.62			QP	
5		316.1500	43.68	-11.59	32.09	46.00	-13.91			QP	
6		429.6400	39.40	-8.90	30.50	46.00	-15.50			QP	

*:Maximum data x:Over limit !:over margin

Operator: KK

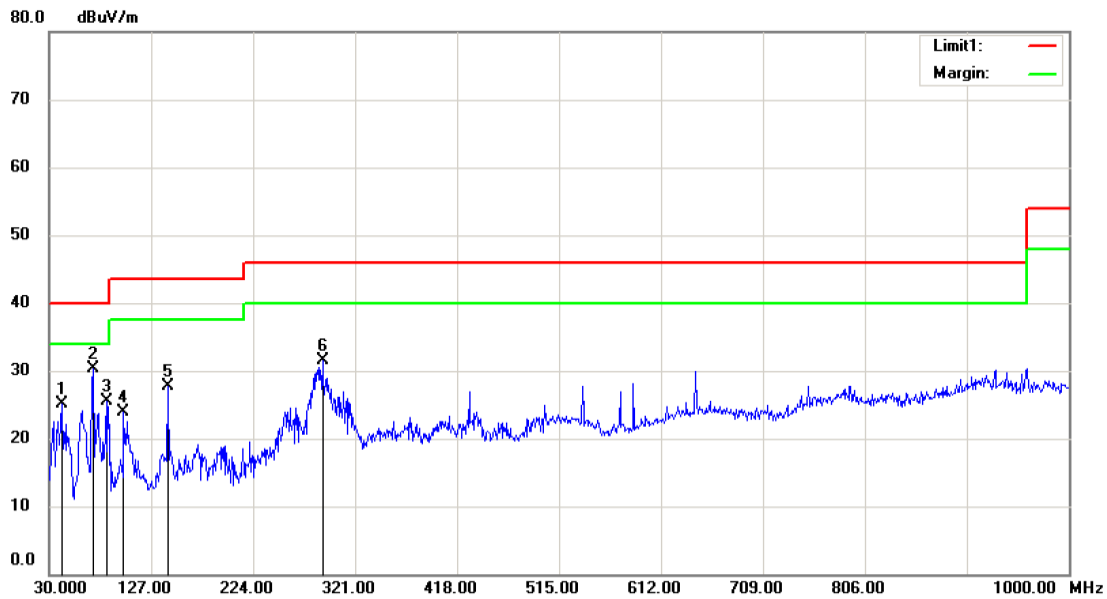

Site 3m Chamber #1 Polarization: **Vertical** Temperature: 24 C
 Limit: (RE)FCC PART 15 CLASS B Power: AC 120V/60Hz Humidity: 53 %
 Mode:BT 2480
 Note:

No.	Mk.	Freq.	Reading Level	Correct Factor	Measurement	Limit	Over	Antenna Height	Table Degree	
		MHz	dBuV	dB	dBuV/m	dBuV/m	dB	cm	degree	Comment
1		41.6400	36.88	-11.84	25.04	40.00	-14.96			QP
2	*	71.7100	48.64	-18.38	30.26	40.00	-9.74			QP
3		84.3200	43.36	-17.88	25.48	40.00	-14.52			QP
4		100.8100	37.56	-13.57	23.99	43.50	-19.51			QP
5		142.5200	44.84	-17.14	27.70	43.50	-15.80			QP
6		289.9600	42.39	-10.88	31.51	46.00	-14.49			QP

*:Maximum data x:Over limit !:over margin

Operator: KK

■ Spurious Emission Above 1GHz (1GHz to 25GHz)--- For FCC ID:

Bluetooth (GFSK, π/4-DQPSK, 8DPSK) mode have been tested, and the worst result was report as below:

Temperature: 24°C Test Date: November 22, 2014
 Humidity: 53 % Test By: KK
 Test mode: GFSK Frequency: Channel 0: 2402MHz

Freq. (MHz)	Ant.Pol. H/V	Emission Level(dBuV/m)		Limit 3m(dBuV/m)		Over(dB)	
		PK	AV	PK	AV	PK	AV
4824.00	V	59.55	40.64	74.00	54.00	-14.45	-13.36
7236.00	V	48.29	31.90	74.00	54.00	-25.71	-22.10
9648.00	V	48.59	32.60	74.00	54.00	-25.41	-21.40
12060.00	V	49.70	33.90	74.00	54.00	-24.30	-20.10
14472.00	V	51.42	36.52	74.00	54.00	-22.58	-17.48
16884.00	V	52.69	35.50	74.00	54.00	-21.31	-18.50
4824.00	H	61.77	40.90	74.00	54.00	-12.23	-13.10
7236.00	H	51.11	33.60	74.00	54.00	-22.89	-20.40
9648.00	H	50.93	33.90	74.00	54.00	-23.07	-20.10
12060.00	H	50.65	35.10	74.00	54.00	-23.35	-18.90
14472.00	H	50.24	33.40	74.00	54.00	-23.76	-20.60
16884.00	H	52.76	36.50	74.00	54.00	-21.24	-17.50

Test mode: GFSK Frequency: Channel 39: 2441MHz

Freq. (MHz)	Ant.Pol. H/V	Emission Level(dBuV/m)		Limit 3m(dBuV/m)		Over(dB)	
		PK	AV	PK	AV	PK	AV
4876.00	V	59.95	40.30	74.00	54.00	-14.05	-13.70
6457.00	V	51.91	35.20	74.00	54.00	-22.09	-18.80
8412.00	V	50.97	33.60	74.00	54.00	-23.03	-20.40
9449.00	V	51.80	33.90	74.00	54.00	-22.20	-20.10
12543.00	V	50.21	33.10	74.00	54.00	-23.79	-20.90
17745.00	V	53.48	37.10	74.00	54.00	-20.52	-16.90
4876.00	H	60.73	39.50	74.00	54.00	-13.27	-14.50
8395.00	H	50.72	33.90	74.00	54.00	-23.28	-20.10
9636.00	H	51.48	35.10	74.00	54.00	-22.52	-18.90
12254.00	H	51.88	34.70	74.00	54.00	-22.12	-19.30
15807.00	H	52.52	36.30	74.00	54.00	-21.48	-17.70
17592.00	H	53.74	37.20	74.00	54.00	-20.26	-16.80

Test mode: GFSK Frequency: Channel 78: 2480MHz

Freq. (MHz)	Ant.Pol. H/V	Emission Level(dBuV/m)		Limit 3m(dBuV/m)		Over(dB)	
		PK	AV	PK	AV	PK	AV
4961.00	V	60.59	40.30	74.00	54.00	-13.41	-13.70
6389.00	V	51.58	33.60	74.00	54.00	-22.42	-20.40
9551.00	V	49.57	32.50	74.00	54.00	-24.43	-21.50
13478.00	V	50.80	33.10	74.00	54.00	-23.20	-20.90
16487.00	V	52.67	34.90	74.00	54.00	-21.33	-19.10
17932.00	V	53.17	36.50	74.00	54.00	-20.83	-17.50
4961.00	H	58.11	40.10	74.00	54.00	-15.89	-13.90
6338.00	H	51.53	33.90	74.00	54.00	-22.47	-20.10
8412.00	H	51.90	34.60	74.00	54.00	-22.10	-19.40
9517.00	H	52.35	34.60	74.00	54.00	-21.65	-19.40
12934.00	H	52.39	35.10	74.00	54.00	-21.61	-18.90
18000.00	H	53.85	37.10	74.00	54.00	-20.15	-16.90

Note: (1) All Readings are Peak Value (VBW=3MHz) and Peak Value (VBW=10Hz).

(2) Emission Level= Reading Level+Probe Factor +Cable Loss.

(3) Data of measurement within this frequency range shown " -- " in the table above means the reading of emissions are attenuated more than 20dB below the permissible limits or the field strength is too small to be measured.

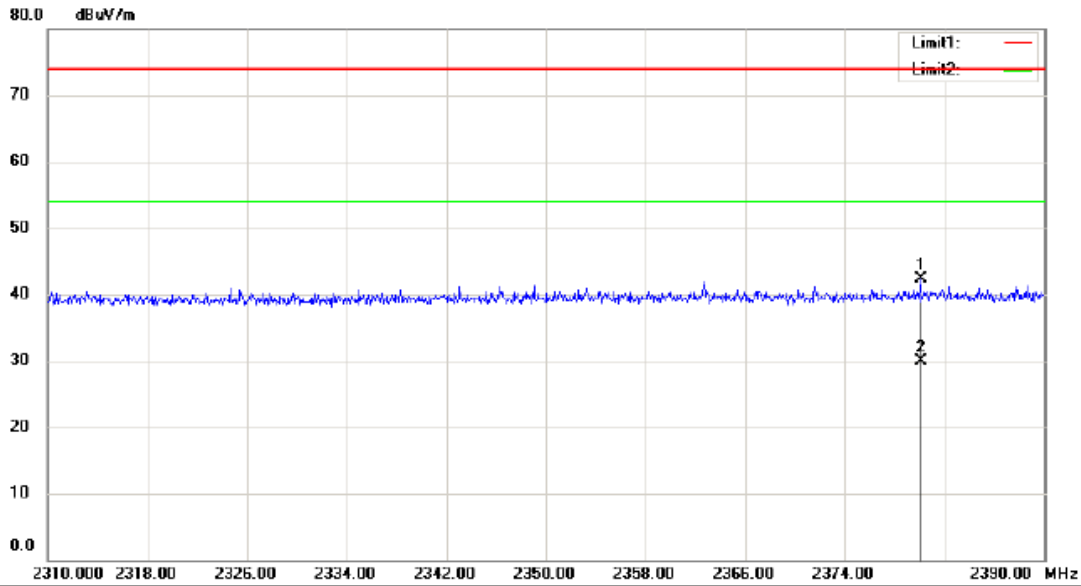

Site 3m Chamber #1 Polarization: **Vertical** Temperature: 24 C
 Limit: (RE)FCC PART 15 CLASS B Power: AC 120V/60Hz Humidity: 53 %
 EUT: Table PC
 M/N: Magnus 10A
 Mode:BT 2402
 Note:

No.	Mk.	Freq.	Reading Level	Correct Factor	Measurement	Limit	Over	Antenna Height	Table Degree	
		MHz	dBuV	dB	dBuV/m	dBuV/m	dB	cm	degree	Comment
1		2380.080	50.60	-8.31	42.29	74.00	-31.71			peak
2	*	2380.080	38.31	-8.31	30.00	54.00	-24.00			AVG

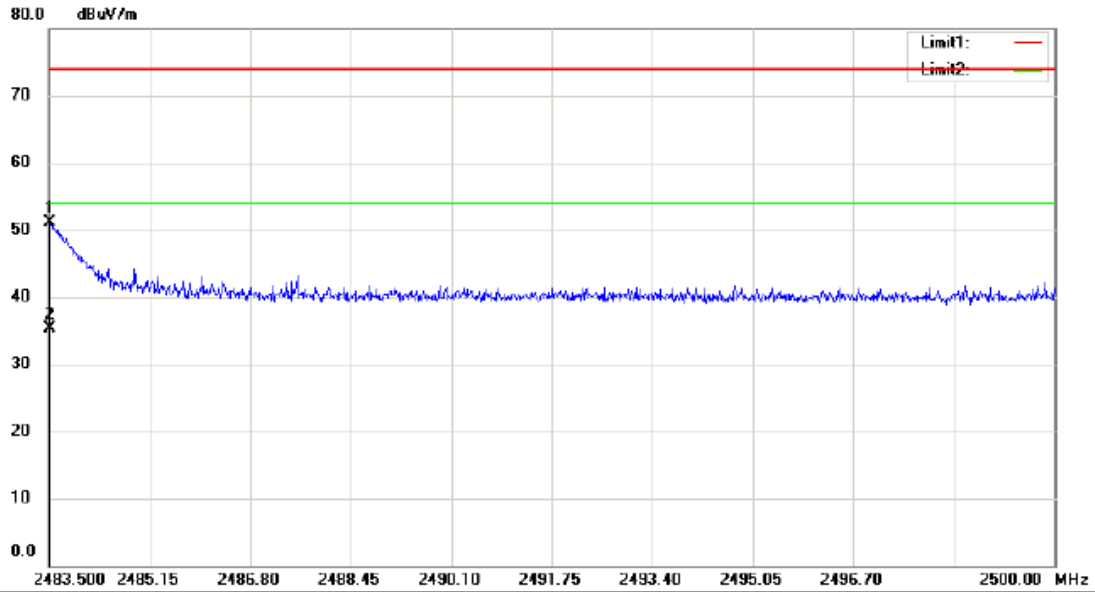

Site: 3m Chamber #1
 Limit: (RE)FCC PART 15 CLASS B
 EUT: Table PC
 M/N: Magnus 10A
 Mode: BT 2480
 Note:

Polarization: *Vertical*
 Power: AC 120V/60Hz
 Temperature: 24 C
 Humidity: 53 %

No.	Mk.	Freq.	Reading Level	Correct Factor	Measurement	Limit	Over	Antenna Height	Table Degree	
		MHz	dBuV	dB	dBuV/m	dBuV/m	dB	cm	degree	Comment
1		2483.500	59.05	-7.89	51.16	74.00	-22.84			peak
2	*	2483.500	43.19	-7.89	35.30	54.00	-18.70			AVG

9.9 CONDUCTED EMISSION TEST

9.9.1 Applicable Standard

According to FCC Part 15.207(a) / IC RSS-Gen 8.8

9.9.2 Conformance Limit

Conducted Emission Limit		
Frequency(MHz)	Quasi-peak	Average
0.15-0.5	66-56	56-46
0.5-5.0	56	46
5.0-30.0	60	50

Note: 1. The lower limit shall apply at the transition frequencies
 2. The limit decreases in line with the logarithm of the frequency in the range of 0.15 to 0.50MHz.

9.9.3 Test Configuration

Test according to clause 7.3 conducted emission test setup

9.9.4 Test Procedure

The EUT was placed on a table which is 0.8m above ground plane.
 Maximum procedure was performed on the highest emissions to ensure EUT compliance.
 Repeat above procedures until all frequency measured were complete.

9.9.5 Test Results

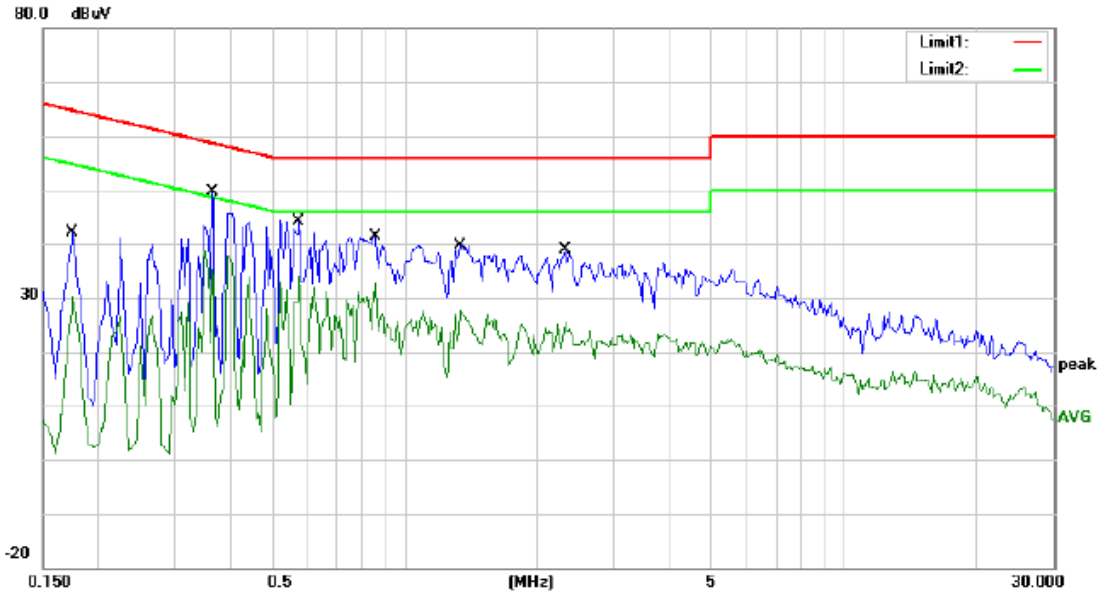

Site Conducted #3
 Limit: (CE)FCC PART 15 class B_QP
 EUT: Tablet PC
 M/N: Magnus 10A
 Mode: Bluetooth
 Note:

Phase: **L1**
 Power: AC 120V/60Hz

Temperature: 23
 Humidity: 55 %

No.	Mk.	Freq. MHz	Reading Level dBuV	Correct Factor dB	Measure- ment dBuV	Limit dBuV	Over dB	Detector	Comment
1		0.1750	42.23	0.00	42.23	64.72	-22.49	QP	
2		0.1750	30.12	0.00	30.12	54.72	-24.60	AVG	
3	*	0.3650	49.72	0.00	49.72	58.61	-8.89	QP	
4		0.3650	38.71	0.00	38.71	48.61	-9.90	AVG	
5		0.5750	44.20	0.00	44.20	56.00	-11.80	QP	
6		0.5750	34.13	0.00	34.13	46.00	-11.87	AVG	
7		0.8550	41.28	0.00	41.28	56.00	-14.72	QP	
8		0.8550	32.66	0.00	32.66	46.00	-13.34	AVG	
9		1.3350	39.75	0.00	39.75	56.00	-16.25	QP	
10		1.3350	27.65	0.00	27.65	46.00	-18.35	AVG	
11		2.3100	38.86	0.00	38.86	56.00	-17.14	QP	
12		2.3100	25.41	0.00	25.41	46.00	-20.59	AVG	

*:Maximum data x:Over limit !:over margin Comment: Factor build in receiver. Operator: ZHL

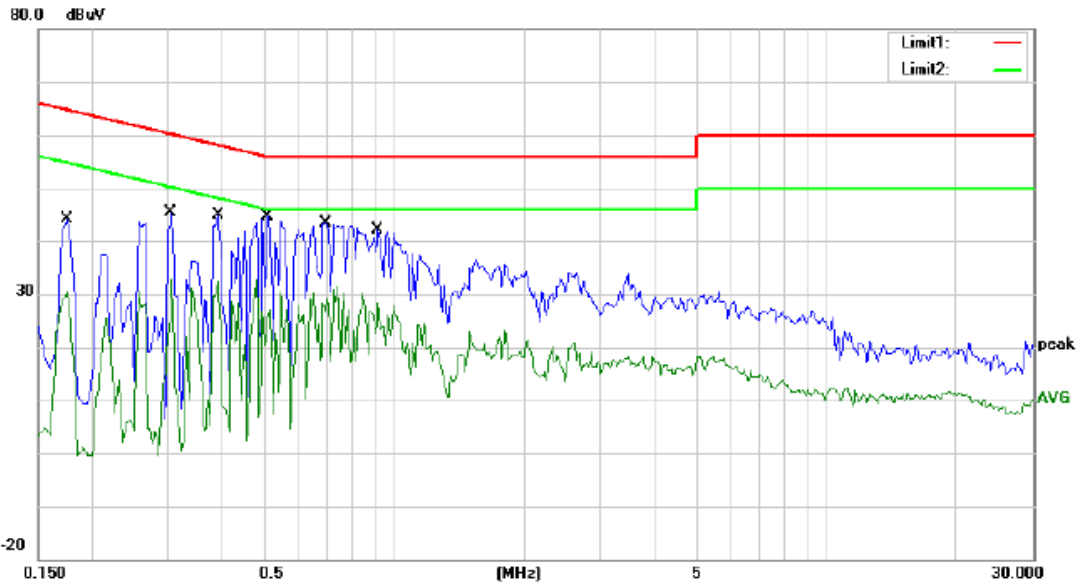

Site Conducted #3
 Limit: (CE)FCC PART 15 class B_QP
 EUT: Tablet PC
 M/N: Magnus 10A
 Mode: Bluetooth
 Note:

Phase: **N** Temperature: 23
 Power: AC 120V/60Hz Humidity: 55 %

No.	Mk.	Freq. MHz	Reading Level dBuV	Correct Factor dB	Measure- ment dBuV	Limit dBuV	Over dB	Detector	Comment
1		0.1750	44.13	0.00	44.13	64.72	-20.59	QP	
2		0.1750	30.44	0.00	30.44	54.72	-24.28	AVG	
3		0.3050	45.33	0.00	45.33	60.11	-14.78	QP	
4		0.3050	32.99	0.00	32.99	50.11	-17.12	AVG	
5		0.3900	44.81	0.00	44.81	58.06	-13.25	QP	
6		0.3900	32.47	0.00	32.47	48.06	-15.59	AVG	
7	*	0.5100	44.63	0.00	44.63	56.00	-11.37	QP	
8		0.5100	32.57	0.00	32.57	46.00	-13.43	AVG	
9		0.6950	43.46	0.00	43.46	56.00	-12.54	QP	
10		0.6950	31.33	0.00	31.33	46.00	-14.67	AVG	
11		0.9150	42.16	0.00	42.16	56.00	-13.84	QP	
12		0.9150	30.07	0.00	30.07	46.00	-15.93	AVG	

*:Maximum data x:Over limit !:over margin Comment: Factor build in receiver. Operator: ZHL

9.10 ANTENNA APPLICATION

9.10.1 Antenna Requirement

Standard	Requirement
FCC CRF Part 15.203	An intentional radiator shall be designed to ensure that no antenna other than that furnished by the responsible party shall be used with the device. The use of a permanently attached antenna or of an antenna that uses a unique coupling to the intentional radiator shall be considered sufficient to comply with the provisions of this section. The manufacturer may design the unit so that a broken antenna can be replaced by the user, but the use of a standard antenna jack or electrical connector is prohibited. This requirement does not apply to carrier current devices or to devices operated under the provisions of §15.211, §15.213, §15.217, §15.219, or §15.221. Further, this requirement does not apply to intentional radiators that must be professionally installed, such as perimeter protection systems and some field disturbance sensors, or to other intentional radiators which, in accordance with §15.31(d), must be measured at the installation site. However, the installer shall be responsible for ensuring that the proper antenna is employed so that the limits in this part are not exceeded.

For intentional device, according to FCC 47 CFR Section 15.203, an intentional radiator shall be designed to ensure that no antenna other than that furnished by the responsible party shall be used with the device. And according to FCC 47 CFR Section 15.247 (b), if transmitting antennas of directional gain greater than 6dBi are used, the power shall be reduced by the amount in dB that the directional gain of the antenna exceeds 6dBi.

For intentional device, according to IC RSS-Gen 8.3, testing shall be performed using the highest gain antenna of each combination of licence-exempt transmitter and antenna type, with the transmitter output power set at the maximum level.9 When a measurement at the antenna connector is used to determine RF output power, the effective gain of the device’s antenna shall be stated, based on a measurement or on data from the antenna manufacturer.

9.10.2 Result

Note: Antenna use a permanently attached antenna which is not replaceable.
The EUT’S antenna is FIFA antenna. The antenna’s gain is 2dBi and meets the requirement.

END OF REPORT