

Sea Tel Tracker 6000 Satellite Antenna Installation Manual

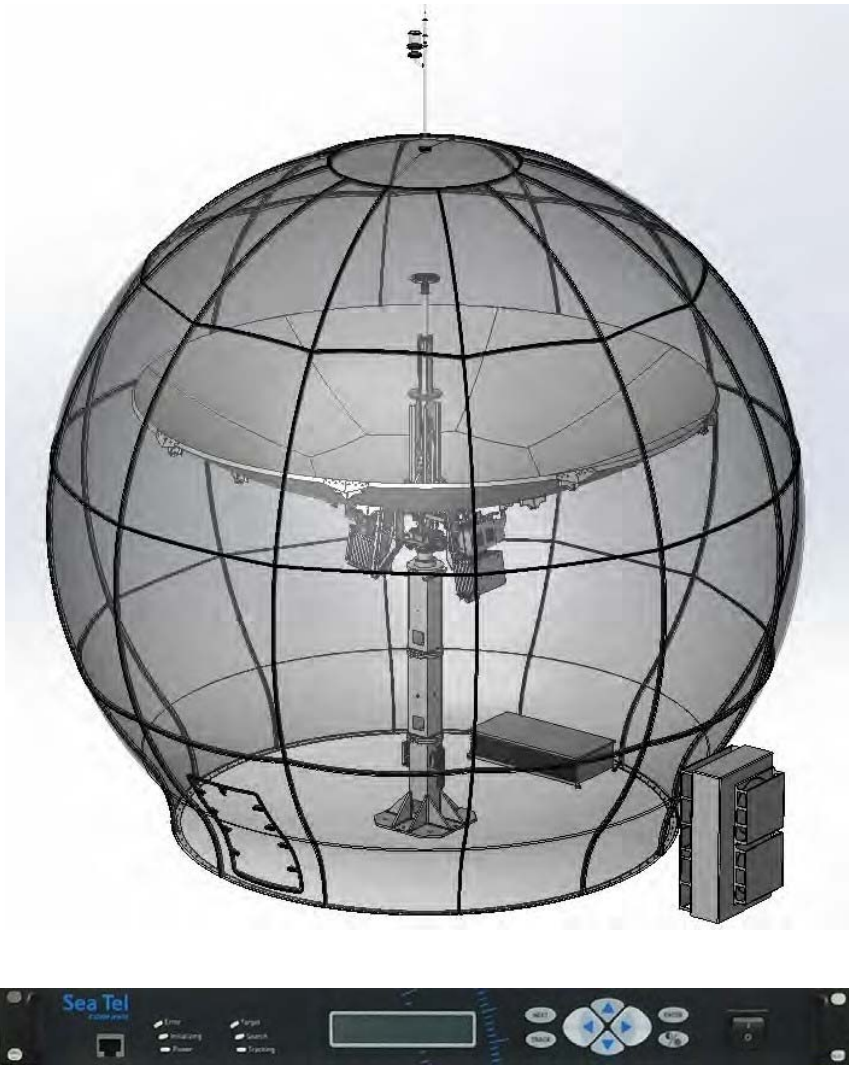

EAR Controlled - ECCN EAR99

This technical data is subject to US Government export control in accordance with the Export Administration Regulations. Export of this data to any foreign country, or disclosure of this data to a Non-US person, may be a violation of Federal law.

<p>Sea Tel, Inc. (trading as Cobham SATCOM) 4030 Nelson Avenue Concord, CA 94520 Tel: +1 (925) 798-7979 Fax: +1 (925) 798-7986</p>		<p>Thrane & Thrane A/S (trading as Cobham SATCOM) Lundtoftegaardsvej 93 D, 2800 Kgs. Lyngby, Denmark Tel: +45 3955 8800 Fax: +45 3955 8888</p>
<p><i>Web:</i> http://www.cobham.com/satcom</p>		<p><i>Email:</i> satcom.ohc@cobham.com</p>

Sea Tel Tracker 6000



Sea Tel Marine Stabilized Antenna systems are assembled in the United States of America.



These commodities, technology or software were exported from the United States in accordance with the Export Administration Regulations. Diversion contrary to U.S. law is prohibited.



Sea Tel is an ISO 9001:2015 registered company. Certificate Number 13690 originally issued March 14, 2011 and was renewed/reissued on March 9, 2020.

Copyright Notice

Copyright © 2020 Sea Tel Inc. All Rights Reserved. The information contained in this document is proprietary to Sea Tel, Inc.. This document may not be reproduced or distributed in any form without prior written consent of Sea Tel, Inc. The information in this document is subject to change without notice. Sea Tel Inc, is also doing business as Cobham SATCOM – Maritime.

Revision History

REV	DCO#	Date	Description	By
A		August 3, 2020	Production Release	MDN



Cobham SATCOM

Marine Systems, Sea Tel Products
4030 Nelson Ave., Concord
California, 94520 USA

T: +1 (925) 798-7979

F: +1 (925) 288-1420

Maximum Safe RF Exposure Power Levels

Antenna Diameter Meters	Antenna Area cm ²	Typical BUC Power Watts	Peak Power Density mW/cm ²	Nominal Power Density mW/cm ²	Max Safe BUC Power Watts	Peak Power Density mW/cm ²	Nominal Power Density mW/cm ²
0.6	2,827	5	1.8	0.1	25	8.8	0.6
1	7,854	8	1.0	0.1	75	9.5	0.6
1.2	11,310	25	2.2	0.1	100	8.8	0.6
1.5	17,671	25	1.4	0.1	150	8.5	0.5
1.8	25,447	25	1.0	0.1	250	9.8	0.6
2	31,416	50	1.6	0.1	300	9.5	0.6
2.4	45,239	75	1.7	0.1	450	9.9	0.6
3.6	101,788	100	1.0	0.1	1000	9.8	0.6
8797 (2.0)	30,500	50	1.6	0.1	300	9.8	0.6
9797 (2.4)	42,450	100	2.4	0.1	400	9.4	0.6

Notes:

The '**Peak Power Density**' values shown above assume a 100 percent duty cycle modulation of the RF power amplifier (BUC) at its maximum possible output power. No satellite network is ever operated at this extreme level. The '**Nominal Power Density**' values shown above, represent operation with a 10 percent duty cycle modulation and a 2 dB power backoff (0.1 x 0.63). These are realistic values for operation within a network that accommodates multiple users.

The FCC has defined, in document 'OET Bulletin 65', the maximum safe exposure level for controlled environments to be 5 mW/cm² and the maximum safe exposure level for uncontrolled environments to be 1 mW/cm². Clearly, the '**Typical BUC Power**' installations meet this requirement with a safety margin of 10. Furthermore, any system equipped with a BUC or RF power amplifier equal to or less than the '**Max Safe BUC Power**' stated above, is guaranteed to be safe outside the confines of the radome walls.

By contrast, an analog cellular telephone, with a peak power output of 2 Watts produces a power density, averaged over the area of your head of 20 mW/cm². Localized power densities, i.e. next to your ear, can approach 200 mW/cm². Digital cellular telephones typically operate with a duty cycle between 1 and 5 percent making the averaged power density equal to or slightly below the FCC defined safe level. Compared to the table values above, a cellular telephone produces between 10 and 100 times the RF exposure level of a typical Sea Tel satellite terminal.

Peter G. Blaney
Chief Engineer, Sea Tel Products
Cobham SATCOM, Marine Systems

Doc: 99-130856-A

DECLARATIONS for FCC OET BULLETIN 65 Edition 97-01

GlobalStar T6000, 6m Antenna

Compliance with FCC Guidelines for Human exposure to RF Electromagnetic Fields		
Field Description	Value	Notes
Frequency (GHz)	5.249	Highest Transmit Frequency of operation
Antenna Diameter (m)	6	
PA Output Power (W)	250	Maximum Linear ourput power per HPA of 125W, x2
PA to Horn Insertion loss (dB)	-0.9	Includes losses from feed network and PA to Feed Waveguide run
Aperture Efficiency (%)	52%	Refer to Gain budget for detail, includes losses from illumination, spillover, radome and reflector surface tolerance
Transition Region (distance from antenna - R) (m)	250	Representative distance within transition region
Farfield Region (distance from antenna - R) (m)	380	Minimum distance considered FF per OET 65 definition
Max. Power Density at antenna surface (mW/cm2)	2.87	< Controlled exposure limit of 5mW/cm2 (Inside the radome)
Distance from Antenna considered as NF Rnf (m)	157.47	
Max Power density on-Axis in NF Snf (mw/cm2)	1.49	< Controlled exposure limit of 5mW/cm2 on-Axis within NF range. For level surroundings, assuming a minimum transmit elevation angle of 10degrees, <Public Exposure limit of 1mW/cm2 @ distance > 28m
Max. Power density in transition region at distance R (mW/cm2)	0.94	< Public exposure limit of 1mW/cm2 @ 250m on-Axis
Distance from Antenna considered as FF Rff (m)	377.928	
Max. Power density in FF region at distance R (mW/cm2)	0.63	< Public exposure limit of 1mW/cm2

Best Regards,



Date: 07-07-2020

Rami Adada

Director of Technologies, Sea Tel Inc.

4030 Nelson Ave, Concord, CA, 94520

+1 (925) 798-7979

Declaration of Potentially Hazardous Materials on-board

This declaration is for the Green Passport Requirement (Based on Annex 2 to the Industry Code of Practice on Ship Recycling, August 2001.*).

This inventory is part of the ship's Green Passport and provides information with regard to materials known to be potentially hazardous and utilized in the construction of the ship, its equipment and systems. It may be supplemented, as appropriate, with technical information in respect of certain categories of potentially hazardous materials listed in this document, particularly with regard to their proper removal and handling.

The Equipments Maker / Supplier have to declare if his equipment/equipments contain any of the hazardous materials listed below with concentration and duly signed and stamped.

Vessel Name/Hull Number/Shipyard:

Equipment Details: **All Sea Tel manufactured antenna systems.**

Supplier Details:

Sea Tel, Inc
 4030 Nelson Ave
 Concord, CA. 94520
 Tel: +01 925 798 7979

PART 1 – POTENTIALLY HAZARDOUS MATERIALS IN THE SHIP STRUCTURE AND EQUIPMENT

1A. ASBESTOS

Type of Asbestos Materials in System / Equipment / Component	Approximate quantity / volume
N/A	0

1B. Paint with Additives (Lead, Tin, Cadmium, Organotin (TBTs), Arsenic, Zinc, Chromium, Strontium, Other)

Type of Additives	Materials containing additives	Location (If Applicable)	Approximate Quantity
N/A	N/A	N/A	0

1C. Plastic Materials

Type	Components containing plastic materials	Location (If Applicable)	Approximate quantity / volume
N/A	N/A	N/A	0

1D. Materials containing PCBs, PCTs, PBBs at levels of 50mg/kg or more

Type PCBs/PCTs/PBBs	Components containing such materials	Location (If Applicable)	Approximate quantity / volume
N/A	N/A	N/A	0

1E. Gases sealed in the equipment or machinery of supplied system

Type	Equipment/Component containing such gases	Location (If Applicable)	Approximate quantity / volume
Refrigerants (R12/R22)	N/A	N/A	0
HALON	N/A	N/A	0
CO ²	N/A	N/A	0
Acetylene	N/A	N/A	0
Propane	N/A	N/A	0
Butane	N/A	N/A	0
Oxygen	N/A	N/A	0
Other (Specify)	N/A	N/A	0

1F. Chemicals in the equipment or machinery of supplied system

Type of chemicals	Equipment/Component containing such chemicals	Location (If Applicable)	Approximate quantity / volume
Anti-seize Compounds	N/A	N/A	0
Engine Additives	N/A	N/A	0
Antifreeze Fluids	N/A	N/A	0
Kerosene	N/A	N/A	0
White Spirit	N/A	N/A	0
Boiler/Water Treatment	N/A	N/A	0
De-ioniser Regenerating	N/A	N/A	0
Evaporator Dosing and	N/A	N/A	0
Descaling Acids	N/A	N/A	0
Paint/Rust Stabilisers	N/A	N/A	0
Solvents/Thinners	N/A	N/A	0
Chemical Refrigerants	N/A	N/A	0
Battery Electrolyte	N/A	N/A	0
Hotel Service Cleaners	N/A	N/A	0
Other (Specify)	N/A	N/A	0

1G. Other Substances inherent in the machinery, equipment or fittings of supplied system

Type	Equipment/Component containing such chemicals	Location (If Applicable)	Approximate quantity / volume
Lubricating Oil	N/A	N/A	0
Hydraulic Oil	N/A	N/A	0
Lead Acid Batteries	N/A	N/A	0
Alcohol	N/A	N/A	0
Methylated Spirits	N/A	N/A	0
Epoxy Resins	N/A	N/A	0
Mercury	N/A	N/A	0
Radioactive Materials	N/A	N/A	0
Other (Specify)	N/A	N/A	0

All of the plastics used on Sea Tel antenna systems are completely inert and pose no harm when in use or when scrapped.

All of the lubricating oils used on Sea Tel antenna systems are completely inert and pose no harm when in use or when scrapped.

All of the anti-seize compounds used on Sea Tel antenna systems are completely inert and pose no harm when in use or when scrapped.

We hereby declare that the above inventory of potentially hazardous material truly correspond to the equipment/equipments supplied to ship.



Dec 04, 2017

John Phillips
 VP Engineering
 Sea Tel, Inc 4030
 Nelson Ave.
 Concord, CA. 94520
 Tel: +01 925 798 7979

Date

This Page Intentionally Left Blank

- 1. SAFETY 1-1**
- 2. SITE SURVEY – LAND BASED 2-1**
 - 2.1. SITE SELECTION2-1
 - 2.2. ANTENNA SHADOWING (BLOCKAGE) AND RF INTERFERENCE2-1
 - 2.3. MOUNTING FOUNDATION.....2-2
 - 2.3.1. *Mounting on a Concrete Pad*.....2-2
 - 2.4. BELOW DECKS EQUIPMENT LOCATION.....2-2
 - 2.5. CABLES2-2
 - 2.5.1. *ADE/BDE Coaxial Cables*.....2-2
 - 2.5.2. *Antenna Power Cable*.....2-3
 - 2.5.3. *ACU Power Cable/Outlet*.....2-3
 - 2.5.4. *Gyro Compass Cable*.....2-3
 - 2.6. GROUNDING.....2-3
- 3. INSTALLATION 3-1**
 - 3.1. GENERAL CAUTIONS & WARNINGS3-1
 - 3.2. PREPARATION3-1
 - 3.3. PREPARING LOCATION FOR THE OUT DOOR UNIT (ODU)3-2
 - 3.3.1. *Lay Out ODU Mounting Holes*.....3-2
 - 3.3.2. *Open General Assembly Crate*.....3-2
 - 3.3.3. *Mount the Base section of the Pedestal*.....3-3
 - 3.3.4. *Open Radome Crates (2)*.....3-3
 - 3.3.5. *Assembling the Bottom Layer of the Radome*.....3-4
 - 3.3.6. *Assembling the Top Layer of the Radome*.....3-5
 - 3.3.7. *Assembling the Third Layer of the Radome*.....3-6
 - 3.3.8. *Assembling the Fourth Layer of the Radome*.....3-7
 - 3.4. ASSEMBLING THE PEDESTAL.....3-8
 - 3.5. ASSEMBLING THE REFLECTOR3-12
 - 3.6. INSTALLING THE REFLECTOR.....3-14
 - 3.7. CLOSING THE RADOME3-17
 - 3.8. CONNECTIONS INTO THE ODU.....3-18
 - 3.9. INSTALLING MAINTENANCE MODE SWITCH & DOOR SENSOR3-18
 - 3.10. PEDESTAL INTERIOR CONNECTIONS3-18
 - 3.11. INSTALLING INTERIOR LIGHTING.....3-19
 - 3.12. REMOVE THE SERVICE BRACKETS3-19
 - 3.13. FINAL CHECKS.....3-20
- 4. SETUP & TESTING 4-1**
- 5. MAINTENANCE..... 5-1**
 - 5.1. SAFETY 5-1
 - 5.2. WARRANTY INFORMATION.....5-1
 - 5.3. TORQUE AND LOCTITE SPECIFICATIONS5-2
 - 5.4. BALANCING THE ANTENNA5-2
- 6. STOWING THE ANTENNA..... 6-1**
 - 6.1. INSTALLING THE SERVICE BRACKETS6-1
 - 6.2. REMOVE THE SERVICE BRACKETS6-1
- 7. TRACKER 6000 TECHNICAL SPECIFICATIONS 7-1**
 - 7.1. OUT DOOR UNIT (ODU).....7-1

7.2. REGULATORY COMPLIANCE7-9

8. TRACKER 6000 DRAWINGS.....8-1

8.1. MODEL SPECIFIC DRAWINGS.....8-1

1. Safety

The following general safety precautions must be observed during all phases of operation, service and repair of this equipment. Failure to comply with these precautions or with specific warnings elsewhere in this manual violates safety standards of design, manufacture and intended use of the equipment. Sea Tel Inc (dba Cobham SATCOM) assumes no liability for the customer's failure to comply with these requirements.

Service

Access to the interior of the Out Door Unit (ODU), is allowed for inspection of components by a technician/engineer. Maintenance of the ODU should only be performed by technicians/engineers who are authorized by Cobham SATCOM. Only authorized Partners who have received factory training on this equipment will be able to file a claim for warranty reimbursement. Failure to comply with standard practices, which include but are not limited to modification of the terminal away from factory documented assemblies may also void the warranty period.

Do not service or adjust alone

Do not attempt internal service or adjustments unless another person, capable of rendering first aid resuscitation, is present.

Personal Protection Equipment (PPE):

Hard hat, safety glasses and steel toe work boots are required.

To avoid injuries, it is important to be aware of the risks present when handling and testing an antenna from inside the dome. There is a risk of the antenna injuring the operator, as the antenna moves, so the operator must be aware of the position of the antenna at all times while inside the radome.

Grounding, cables and connections

To minimize shock hazard and to protect against lightning, the equipment chassis and cabinet must be connected to an electrical ground. The ODU equipment must be grounded to a known good earth ground. For further grounding information refer to the Installation chapter of this manual.

Do not extend the cables beyond the lengths specified for the equipment. The cables between the ODU and the Baseband Equipment Rack must comply with the specified data concerning cable losses etc.

Power supply

AC Power to the ADE is provided by a separate, breakered, power source.

Do not operate in an explosive atmosphere

Do not operate the equipment in the presence of flammable gases or fumes. Operation of any electrical equipment in such an environment constitutes a definite safety hazard.

Keep away from live circuits

Operating personnel must not remove equipment covers. Component replacement and internal adjustment must be made by qualified maintenance personnel. Do not replace components with the power cable connected. Under certain conditions, dangerous voltages may exist even with the power cable removed. To avoid injuries, always disconnect power and discharge circuits before touching them.

SAFETY: INTERNAL BATTERY

The main PCB inside the TICU contains a lithium battery. These batteries should last for many years but if replacement is required, use caution. These batteries are only to be replaced by a technician authorized by Cobham SATCOM to perform such service.



CAUTION - RISK OF EXPLOSION IF BATTERY IS REPLACED BY AN INCORRECT TYPE. DISPOSE OF USED BATTERIES ACCORDING TO THE INSTRUCTIONS.

Failure to comply with the rules above will void the warranty!

This Page Intentionally Left Blank

2. Site Survey – Land Based

There are three objective of the site survey. The first is to find the best place to mount the antenna and the BDE. The second is to identify the length and routing of the cables and any other items or materials that are required to install the system. The third is to identify any other issues that must be resolved before or during the installation.

2.1. Site Selection

The radome assembly should be installed on a shore based concrete pad, where:

- The antenna has a clear line-of-sight to view as much of the sky (horizon to zenith at all bearings) as is practical.
- S-Band (10cm) Radars - The ADE should be mounted more than 4 meters/12 feet from an S-band Radar.
- The ADE should not be mounted on the same plane as the radar, so that it is not directly in the radar beam path.
- The ADE should be mounted more than 2.5 meters/8 feet from any high power MF/HF antennas (<400W).
- The ADE should be mounted more than 4 meters/12 feet from any high power MF/HF antennas (1000W).
- The ADE should also be mounted more than 4 meters/12 feet from any short range (VHF/UHF) antennae.
- The ADE should be mounted more than 2.5 meters/8 feet away from any L-band satellite antenna.
- The ADE should be mounted more than 3 meters/10 feet away from any magnetic compass installations.
- The ADE should be mounted more than 2.5 meters/8 feet away from any GPS receiver antennae.
- Another consideration for any satellite antenna mounting is multi-path signals (reflection of the satellite signal off of nearby surfaces arriving out of phase with the direct signal from the satellite) to the antenna.
- The ADE and the BDE should be positioned as close to one another as possible. This is necessary to reduce the losses associated with long cable runs.
- The mounting location far enough away from surrounding buildings, towers, cranes or other structures will also cause significant degradation of the signal when in direct line-of-sight between the antenna and the LEO satellite it is tracking.

If these conditions cannot be entirely satisfied, the site selection will inevitably be a “best” compromise between the various considerations.

2.2. Antenna Shadowing (Blockage) and RF Interference

At the transmission frequencies of this satellite antenna system, any substantial structures in the way of the beam path will cause significant degradation of the signal. Care should be taken to locate the ADE so that it has direct line-of-sight with the satellite without any structures in the beam path through the full 360 degrees of ships turn, or 360 degrees around the antenna. Wire rope stays, lifelines, small diameter handrails and other accessories may pass through the beam path in limited numbers; however, even these relatively insignificant shadows can produce measurable signal loss at these frequencies.

Surrounding buildings, towers, cranes or other structures will also cause significant degradation of the signal when in direct line-of-sight between the antenna and the LEO satellite it is tracking.

2.3. Mounting Foundation

2.3.1. Mounting on a Concrete Pad

When installing the antenna on a concrete pad in a land based configuration, care should be taken to locate the ADE away from surrounding buildings, towers, cranes or other structures that will cause significant degradation of the signal when in direct line-of-sight between the antenna and the LEO satellite it is tracking.

The ADE should be mounted on a contractor grade concrete pad with multiple attachment points around the perimeter of the base frame to mount the ADE (refer to the Installation Arrangement drawing for more information). The installation must allow access through a door in one of the side panels.

2.4. Below Decks Equipment Location

The Antenna Control Unit and other equipment that are standard 19" rack mount design should be installed in one of these racks. Plan to allow access to the rear of the equipment in the rack.

The Satellite Receiver, router, computers and any other associated equipment should be properly mounted per their design.

2.5. Cables

During the site survey, walk the path where the cables will be installed. Pay particular attention to how cables will be installed; such as what obstacles they will be routed around, difficulties that will be encountered and the overall length of the cables. The ADE should be installed using good electrical practice. Sea Tel recommends referring to IEC 60092-352 for specific guidance in choosing cables and installing cables onboard a ship. Within these guidelines, Sea Tel will provide some very general information regarding the electrical installation.

In general, all cable shall be protected from chaffing and secured to a cableway. Cable runs on open deck or down a mast shall be in metal conduit suitable for marine use. The conduit shall be blown through with dry air prior to passing cable to ensure all debris has been cleared out of the conduit and again after passing the cable to ensure no trapped moisture exists. The ends of the conduit shall be sealed with cable glands (preferred), mastic or low VOC silicon sealant after the cables have been passed through.

Cables passing through bulkheads or decks shall be routed through approved weather tight glands.

2.5.1. ADE/BDE Coaxial Cables

The first concern with the coaxial cables installed between the ADE & BDE is length. This length is used to determine the loss of the various possible coax, Heliac or fiber-optic cables that might be used. You should always provide the lowest loss cables to provide the strongest signal level into the satellite modem.

Be sure that the shield(s) of the coaxes are not in contact with the ships ground.

The coaxes must be of adequate conductor cross-sectional surface area for the length of the cable run and that the loop resistance of the cable run is less than 2.0 ohms. Copper clad iron center conductor cables should never be used.

Signal cable shall be continuous from the connection within the ADE radome, through the structure of the ship to the BDE. Splices, adapters or dummy connections will degrade the signal level and are discouraged.

Be careful of sharp bends that kink and damage the cable. Use a proper tubing bender for Heliac bends.

Penetrations in watertight bulkheads are very expensive, single cable, welded penetrations that must be pressure tested.

Always use good quality connectors that are designed to fit properly on the cables you are using. Poor quality connectors have higher loss, can allow noise into the cable, are easily damaged or fail prematurely.

In as much as is possible, don't lay the coaxes on power cables. Don't lay the coaxes on, or directly beside, the cables from a second Sea Tel antenna, Inmarsat antenna and/or GPS antenna that are also passing L-band frequencies. Don't lay the coaxes on, or directly beside, radar cables that may inject pulse repetition noise –as error bits - into your cables.

2.5.2. Antenna Power Cable

Be cautious of length of the run, for voltage loss issues, and assure that the gauge of the wires is adequate for the current that is expected to be drawn (plus margin). Antenna power is recommended (but not required) to be from a UPS, generally the same one that supplies power to the below decks equipment.

Power cables shall comply with the provisions of IEC 60092-350 and -351 as practical. Power cables may be routed through the same conduit as the signal cable from the junction box to the base of the ADE. Power cables shall pass through separate radome penetrations from the signal cable.

The power cable shall be continuous from the UPS (or closest circuit breaker) to the ADE connections within the radome. The power circuits shall be arranged so that 'active,' 'common' and 'neutral' (ground) legs are all made or broken simultaneously. All circuit legs shall be carried in the same cable jacket.

2.5.3. ACU Power Cable/Outlet

The AC power for the ACU and the ADE is not required to be from a UPS (same one that supplies power to the ADE), but it is recommended.

Power cable shall comply with the provisions of IEC 60092-350 and -351 in so far as practicable.

2.5.4. Gyro Compass Cable

Use good quality shielded cables (twisted pairs, individually foil wrapped, outer foil with braid overall is best). You only need 2-wires for NMEA Compass signal. Be cautious of length and gauge of the run for voltage loss issues.

2.6. Grounding

Refer to the Installation chapter for grounding/bonding information.



This Page Intentionally Left Blank

3. Installation

This section contains instructions for unpacking, final assembly and installation of the equipment. *It is highly recommended that final assembly and installation of the Antenna system be performed by trained technicians.* Read this complete chapter before starting.

NOTE: This antenna is to be installed in a secured, gated, site ONLY.

3.1. General Cautions & Warnings

	<p>WARNING: Assure that all nut and bolt assemblies are tightened according to the tightening torque values listed below:</p>																				
	<table border="1"> <thead> <tr> <th>SAE Bolt Size</th> <th>Inch Pounds</th> <th>Metric Bolt Size</th> <th>Kg-cm</th> </tr> </thead> <tbody> <tr> <td>1/4-20</td> <td>75</td> <td>M6</td> <td>75.3</td> </tr> <tr> <td>5/16-18</td> <td>132</td> <td>M8</td> <td>150</td> </tr> <tr> <td>3/8-16</td> <td>236</td> <td>M10</td> <td>270</td> </tr> <tr> <td>1/2-13</td> <td>517</td> <td>M12</td> <td>430</td> </tr> </tbody> </table>	SAE Bolt Size	Inch Pounds	Metric Bolt Size	Kg-cm	1/4-20	75	M6	75.3	5/16-18	132	M8	150	3/8-16	236	M10	270	1/2-13	517	M12	430
SAE Bolt Size	Inch Pounds	Metric Bolt Size	Kg-cm																		
1/4-20	75	M6	75.3																		
5/16-18	132	M8	150																		
3/8-16	236	M10	270																		
1/2-13	517	M12	430																		
	<p>NOTE: All nuts and bolts should be assembled using the appropriate Loctite thread-locker product number for the thread size of the hardware.</p> <table border="1"> <thead> <tr> <th>Loctite #</th> <th>Description</th> </tr> </thead> <tbody> <tr> <td>222</td> <td>Low strength for small fasteners.</td> </tr> <tr> <td>242</td> <td>Medium strength</td> </tr> <tr> <td>638</td> <td>High strength for Motor Shafts & Sprockets.</td> </tr> <tr> <td>2760</td> <td>Permanent strength for up to 1" diameter fasteners.</td> </tr> <tr> <td>290</td> <td>Wicking, High strength for fasteners which are already assembled.</td> </tr> </tbody> </table>	Loctite #	Description	222	Low strength for small fasteners.	242	Medium strength	638	High strength for Motor Shafts & Sprockets.	2760	Permanent strength for up to 1" diameter fasteners.	290	Wicking, High strength for fasteners which are already assembled.								
Loctite #	Description																				
222	Low strength for small fasteners.																				
242	Medium strength																				
638	High strength for Motor Shafts & Sprockets.																				
2760	Permanent strength for up to 1" diameter fasteners.																				
290	Wicking, High strength for fasteners which are already assembled.																				
<p>WARNING: Hoisting the sections of the radome with other than a webbed four-part sling may result in catastrophic crushing of the radome.</p>																					
<p>CAUTION: The sections of the radome are very light for their size and are subject to large swaying motions if hoisted under windy conditions. Always ensure that tag lines, attached to the base of the radome sections, are attended while the assembly is being hoisted to its assigned location.</p>																					

3.2. Preparation

Read this entire assembly procedure **before** beginning.

Refer to the System Block diagram, Antenna Schematic, General & and lower level Assembly drawings, Radome Hole Pattern layout, All Radome Assembly & Installation drawings for your system. We recommend that you place the crates in the area that you have chosen to assemble each of these major components. It is recommended that you do not unpack the crates until you are ready to sub-assemble and install the equipment.

Assure that you have a large, flat, level, open area to sub-assemble the general assembly and the upper & lower sections of the radome. This area should be clean and free of debris. The site should also provide protection from wind, rain and other adverse weather.

A hoist, or small crane, is needed to assemble these sub-assemblies to form the final Out Door Unit (ODU) Assembly.

You can change order of these steps; however, in the end the objective is to have a well sealed radome with flanges that well aligned and are clean of excess caulking.

3.3. Preparing Location for the Out Door Unit (ODU)

3.3.1. Lay Out ODU Mounting Holes

The first step is to lay out the holes in the concrete pad for the base of the pedestal and the bottom of the fiberglass radome to be bolted down onto.

Refer to drawing 94-163300-A SITE ARRANGEMENT, RADOME PAD, 8.0M, LEO for the mounting hole pattern and relation to true North.

- The hole pattern of the Pedestal Base MUST be oriented to true North.
- The hole pattern of the Radome Panels MUST be oriented for the entry door to be South, or other desired position relative to true North.

Refer to drawing 97-168704_A01 8M RADOME HOLE MARKING JIG to fabricate a jig for marking the radome mounting hole pattern.

Refer to drawing 99-169359-A T6000 Antenna and Radome Mounting Hole Layout Instructions;

- Locate Center of Installation and True North
During the planning process you will have determined the location for the T6000 antenna, HVAC and radome. Locating the center point of the antenna and radome is a critical first step in laying out all the fastening locations.
- Mounting Holes Related to Center
When completed you will have marked 8 holes for the antenna pedestal and 96 holes for the radome. Both sets of holes depend on center location. Once center is located drill a $\varnothing 5/16''$ hole 2 inches deep in mounting surface for a 1/4-20 female threaded anchor.

3.3.2. Open General Assembly Crate

Move the crate to a location that will not interfere with assembling the ODU. Inventory & Stage components

1. Remove the side panel



- Remove the shipping hardware that mounts the Base of the Pedestal to the pallet of the crate. Discard this hardware.

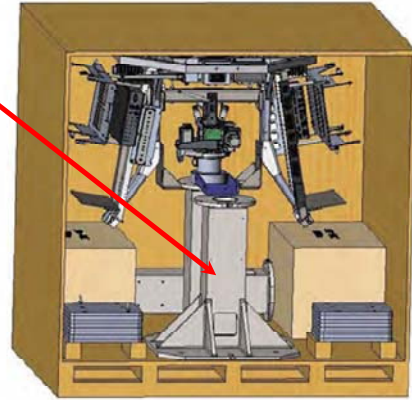

3.3.3. Mount the Base section of the Pedestal

- Locate the base post section (approx. weight 700lbs) to its mounting location on the concrete pad.
- The base MUST be oriented to true North (notch pointing to true North). Rotate the base to align the notch with true North.
- Bolt the pedestal base down on the concrete pad. Apply Loctite to the threads of the 8 mounting bolts/studs. Install the bolts/studs with washers through the base into the anchors in the concrete and tighten to torque spec.



3.3.4. Open Radome Crates (2)

Move the crate to a location that will not interfere with assembling the ODU.
Open the removable panel of Radome Crate 1 & 2. Inventory & Stage components

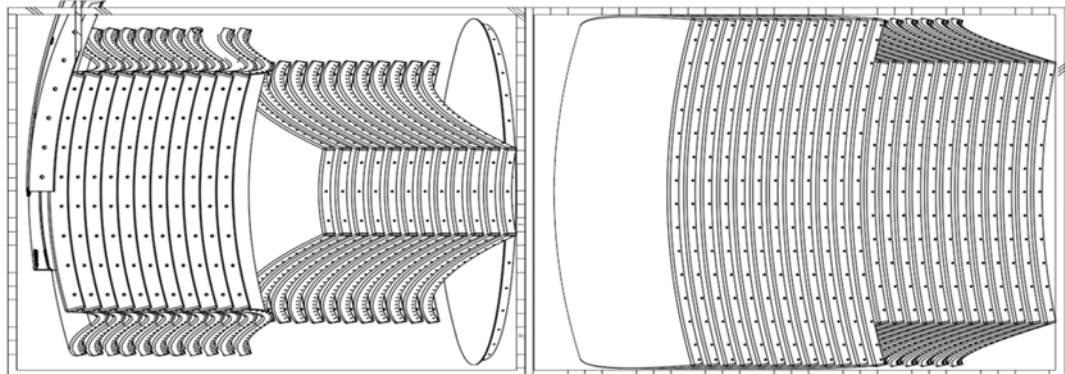

Panels 301-312 201-212 Cap 501-512 401-412

3.3.5. Assembling the Bottom Layer of the Radome

Start assembling the bottom layer panels (serial numbers ending with 501-512) of the radome by bolting them to each other on a flat smooth surface (ie the concrete pad). They are numbered to assure that they are assembled in the correct order.

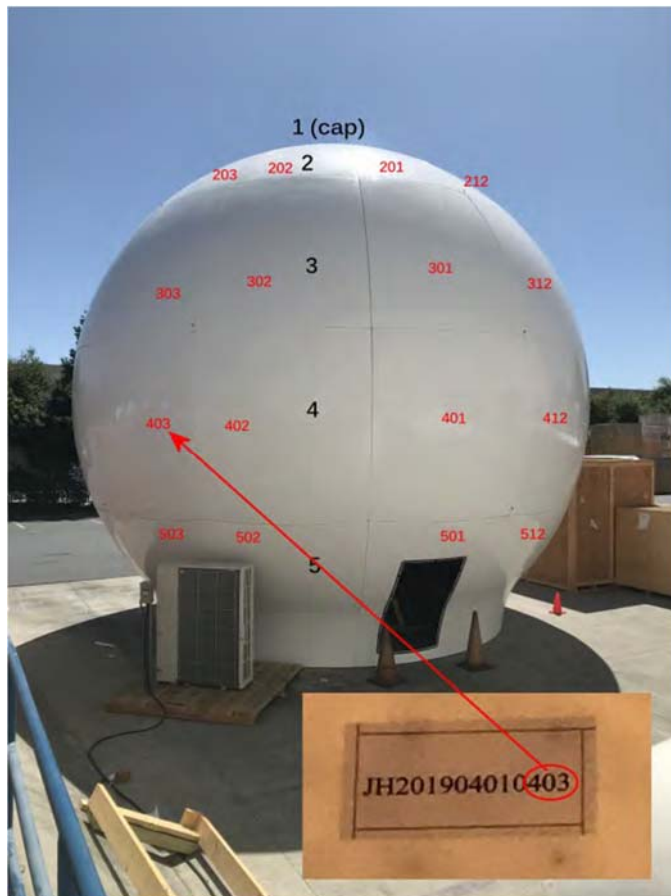

1. Set panels 501 & 502 beside each other and loosely install the vertical flange mounting bolts and washers.
2. While holding those panels, set panel 503 in its correct order position and loosely install the vertical flange mounting bolts and washers.
3. While holding those panels, set panel 504 in its correct order position and loosely install the vertical flange mounting bolts and washers.
4. While holding those panels, set panel 505 in its correct order position and loosely install the vertical flange mounting bolts and washers.
5. Assure that the bottom flange of the panels are sitting down level on the concrete. Apply caulking to mating flange of panels 501 & 502. Apply Loctite to the exposed threads of the bolts and tighten to torque spec from the bottom of the vertical flange to the top. Wipe off the excess caulking from inside and outside of these panels. Repeat with flange 502-503, 503-504 & 504-505.
6. Move/rotate this sub-assembly to assure that the door is oriented South, or other desired location. Then align the bottom holes in these radome panels with the anchors/studs in the concrete pad and loosely start several bolts with washers per panel into the anchors/studs in the concrete. Maintain positive control of these panels [HINT; an empty crate could be positioned against the center of these panels to hold them as you continue installing panels].



7. Apply caulking to the mating flange of the next adjacent panel in correct order and loosely install the vertical flange mounting bolts and washers. Assure that the bottom flange of the panel is sitting down level on the concrete, apply Loctite to the exposed threads of the bolts and tighten to torque spec from the bottom of the vertical flange to the top. Wipe off the excess caulking from inside and outside of this panel flange. Loosely start several bolts with washers per panel into the anchors/studs in the concrete.
8. Repeat step 7 until all of the lower level panels (501-512) have been joined.
9. Apply Loctite to the bolts that mount the base of the radome to the concrete pad. Install bolts & washers and tighten to torque spec starting from the left-most hole in panel 501, removing the previously installed bolts, as you go. Continue installing & tightening bolts with washers until all of the mounting bolts into the concrete are completed in panels 501-512.
10. Apply bead of caulking to the mating of the radome panels to the concrete all the way around the perimeter of the outside of the radome. Repeat applying a bead of caulking to the mating of the radome panels to the concrete all the way around the perimeter of the inside of the radome.



3.3.6. Assembling the Top Layer of the Radome

In a different location, start assembling the top layer panels (serial numbers ending with 201-212 plus the cap) of the radome by bolting them to each other and to the panels below. They are numbered to assure that they are assembled in the correct order (201 is mounted on top of 401, etc).



1. Set panel 201 & 202 beside each other and loosely install the vertical flange mounting bolts and washers. Install a lifting strap on the bottom bolt between these panels.
2. While holding those panels, set panel 203 in its correct order position and loosely install the vertical flange mounting bolts and washers.
3. While holding those panels, set panel 204 in its correct order position and loosely install the vertical flange mounting bolts and washers.
4. While holding those panels, set panel 205 in its correct order position and loosely install the vertical flange mounting bolts and washers. Install a lifting strap on the bottom bolt between these panels.
5. While holding those panels, set panel 206 in its correct order position and loosely install the vertical flange mounting bolts and washers.
6. While holding those panels, set panel 207 in its correct order position and loosely install the vertical flange mounting bolts and washers.



7. Assure that the bottom flange of the panels are sitting down level on the concrete. Apply caulking to mating flange of panels 201 & 202. Apply Loctite to the exposed threads of the bolts and tighten to torque spec from the bottom of the vertical flange to the top. Wipe off the excess caulking from inside and outside of these panels. Repeat with flange 202-203, 203-204, 204-205, 205-206 & 206-207.
8. Repeat step 6 to mount panels 208-211. Install a lifting strap on the bottom bolt between panels 207 & 208 and 210 & 211.
9. Apply a bead of caulking to the bottom of the top flange of the cap. Set the cap into the opening in to top of the upper panels. Align the mounting holes and loosely install the mounting bolts and washers. Apply Loctite to the exposed threads of the bolts and tighten to torque spec the bolts. Wipe off the excess caulking from inside and outside of the cap.
10. Apply a bead of caulking to the vertical sides of panel 212. With someone inside put panel 212 in place, align the mounting holes and loosely install the mounting bolts and washers. Apply Loctite to the exposed threads of the bolts and tighten to torque spec the bolts starting from the cap and then down both sides from the top to the bottom. Wipe off the excess caulking from inside and outside of the cap and panel.
11. Attach a 4-part lifting sling to the lifting straps.
12. Using a suitably rated derrick or crane, lift the top section of the radome about 6 feet to allow installation of the third layer of the radome under the top section.



3.3.7. Assembling the Third Layer of the Radome

With the top section of the radome suspended, start assembling the third layer panels (serial numbers ending with 301-312) of the radome by bolting them to each other and to the panels above. They are numbered to assure that they are assembled in the correct order (301 is mounted to the bottom of 201, etc).

1. Set panel 301 in place under 201 and loosely install the horizontal flange mounting bolts and washers. Apply Loctite to the exposed threads of the bolts, and with the flange open apply a bead of caulking between the panels. Assure that panel 301 is centered on panel 201 and tighten to torque spec the bolts. Wipe off the excess caulking from inside and outside of the panel flange.



2. Apply a bead of caulking to the left and top flanges of panel 302. Set panel 302 in place under 202 and loosely install the vertical & horizontal flange mounting bolts and washers. Apply Loctite to the exposed threads of the bolts and tighten to torque spec the bolts. Install a lifting strap on the bottom bolt between these panels. Wipe off the excess caulking from inside and outside of the panel flanges.
3. Repeat step 2 to mount panels 303-312. Install a lifting strap on the bottom bolt between panels 304 & 305, 307 & 308 and 310 & 311.
4. Set the radome assembly down on the concrete and relocate the 4-part lifting sling to the lifting straps around the base of the third layer of the radome.
5. Lift the radome assembly about 6 feet to allow installation of the fourth layer of the radome under the third section.

3.3.8. Assembling the Fourth Layer of the Radome

With the third section of the radome suspended, start assembling the fourth layer panels (serial numbers ending with 401-412) of the radome by bolting them to each other and to the panels above. They are numbered to assure that they are assembled in the correct order (401 is mounted to the bottom of 301, etc).

1. Set panel 401 in place under 301 and loosely install the horizontal flange mounting bolts and washers. Apply Loctite to the exposed threads of the bolts, and with the flange open apply a bead of caulking between the panels. Assure that panel 301 is centered on panel 301 and tighten to torque spec the bolts. Wipe off the excess caulking from inside and outside of the panel flange.
2. Apply a bead of caulking to the left and top flanges of panel 402. Set panel 402 in place under 302 and loosely install the vertical & horizontal flange mounting bolts and washers. Apply Loctite to the exposed threads of the bolts and tighten to torque spec the bolts. Install a lifting strap on the bottom bolt between these panels. Wipe off the excess caulking from inside and outside of the panel flanges.
3. Repeat step 2 to mount panels 403-412. Install a lifting strap on the bottom bolt between panels 404 & 405, 407 & 408 and 410 & 411.
4. Set the radome assembly down on the concrete and relocate the 4-part lifting sling to the lifting straps around the base of the third layer of the radome.

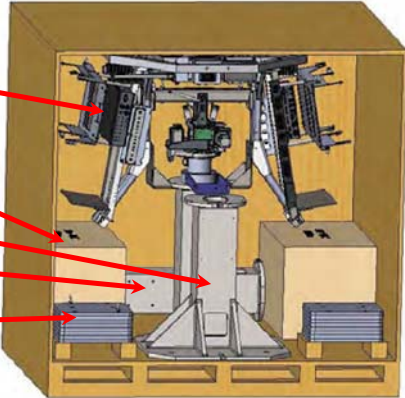
3.4. Assembling the Pedestal

<p>1. Locate the Items in the General Assembly (GA) crate; Equipment Frame and upper post BUC Boxes (left & right)</p> <p>Base post section</p> <p>Middle post section (behind)</p> <p>Counter weight (left & right)</p>	 <p>A 3D cutaway diagram of a yellow shipping crate. Inside, various components are visible: a central vertical assembly (Equipment Frame and upper post), two large rectangular boxes on either side (BUC Boxes), a base section, a middle section behind the base, and two stacks of blue counterweights on the left and right sides. Red arrows point from the text labels to the corresponding parts in the diagram.</p>
<p>2. Remove the sides & top of the GA crate to access the items inside.</p> <p>3. Remove the shipping hardware that mounts the middle post to the pallet of the crate. Discard this hardware.</p> <p>4. Set the middle post section (approx. weight 240lbs) on the base pedestal section. Assure that the notches are aligned to true North.</p> <p>5. Apply Loctite to threads of the mounting bolts. Install the bolts & washers and tighten to torque spec.</p>	 <p>A photograph of the assembled pedestal. The middle post section is mounted on the base pedestal section. A red arrow points to the junction where the two sections meet, indicating the alignment of notches.</p>
<p>6. There is a burnished 6mm threaded hole in the top side of the bottom plate of the middle post section.</p> <p>7. There is another burnished 6mm threaded hole in the under side of the top plate of the Base Stand post section.</p> <p>8. Apply Loctite to threads of 2 6mm bolts. Use the bolts & washers to install a ground strap around the mating of these to plates.</p> <p>9. Tighten the bolts torque spec.</p>	 <p>A photograph of the assembled pedestal, similar to the previous one. A red arrow points to the junction between the middle post section and the base pedestal section, indicating the location for installing a ground strap.</p>

10. Refer to drawing 97-167134_A Assy Drawing, BRACKET KIT, SERVICE, T6000 to install the locking brackets

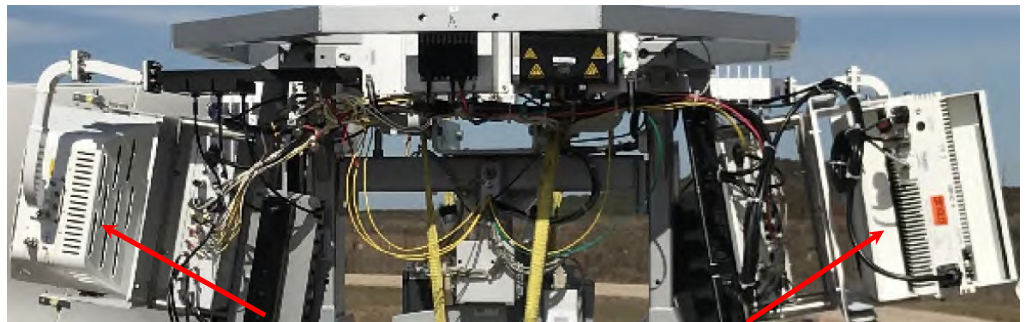
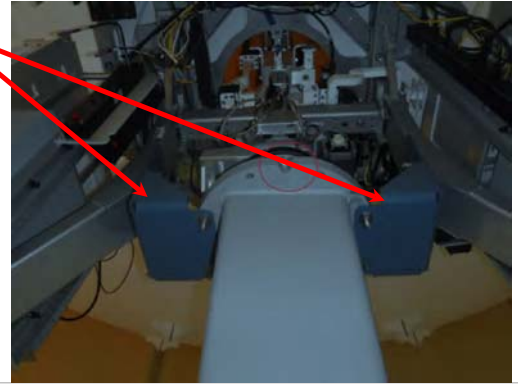

- 11. Remove the shipping hardware that mounts the mount the C-Band BUC boxes to the pallet of the crate. Discard this hardware.
- 12. Open each box and remove the C-Band BUC.
- 13. Install the C-Band BUCs on each side as shown above.
- 14. Connect the cables and waveguide on each side.

15. Install one grounding strap from the equipment frame to the BUC (on BOTH sides).



16. Connect the grounding strap to the BUC (on BOTH sides).



17. Remove the shipping hardware that mounts the mount the Left & Right counter weights to the pallet of the crate. Discard this hardware.

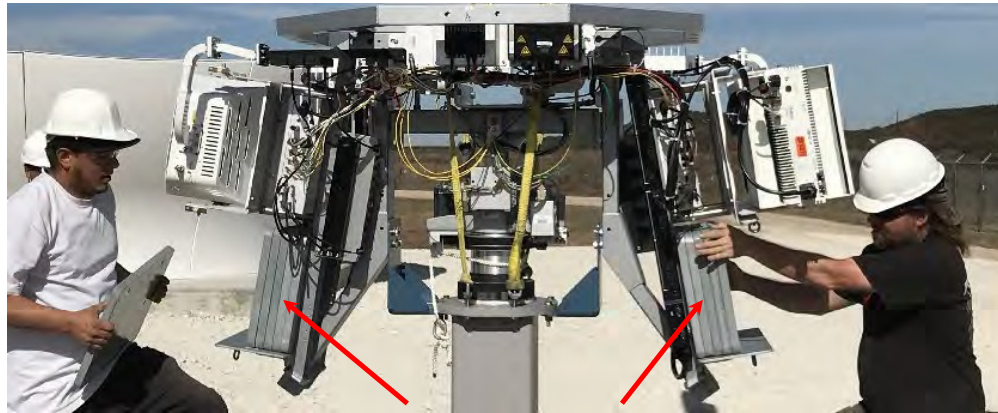

Refer to drawing 97-172014 ASSY DRAWING, BALANCE WEIGHT KIT, T6000 for the following steps (18-23).

18. Mount the large GREY counter weights on the lower Ends of the Equipment Frame as shown above.
19. Apply Loctite to threads of the mounting bolts. Install the bolts & washers and tighten to torque spec.
20. Mount the left side BLUE counter weight (ICU side).
21. Apply Loctite to threads of the mounting bolts. Install the bolts & washers and tighten to torque spec.
22. Mount the right side BLUE counter weight (EL Motor side).
23. Apply Loctite to threads of the mounting bolts. Install the bolts & washers and tighten to torque spec.

24. Install lifting spreader bracket (use assembly drawing 97-167134)

25. Thread lifting straps down through the center of the equipment frame, through the eyes in the spreader bracket, to the lifting eyes installed in the top of the upper post section.

Equipment frame

Lifting eyes (4 each)

Upper post



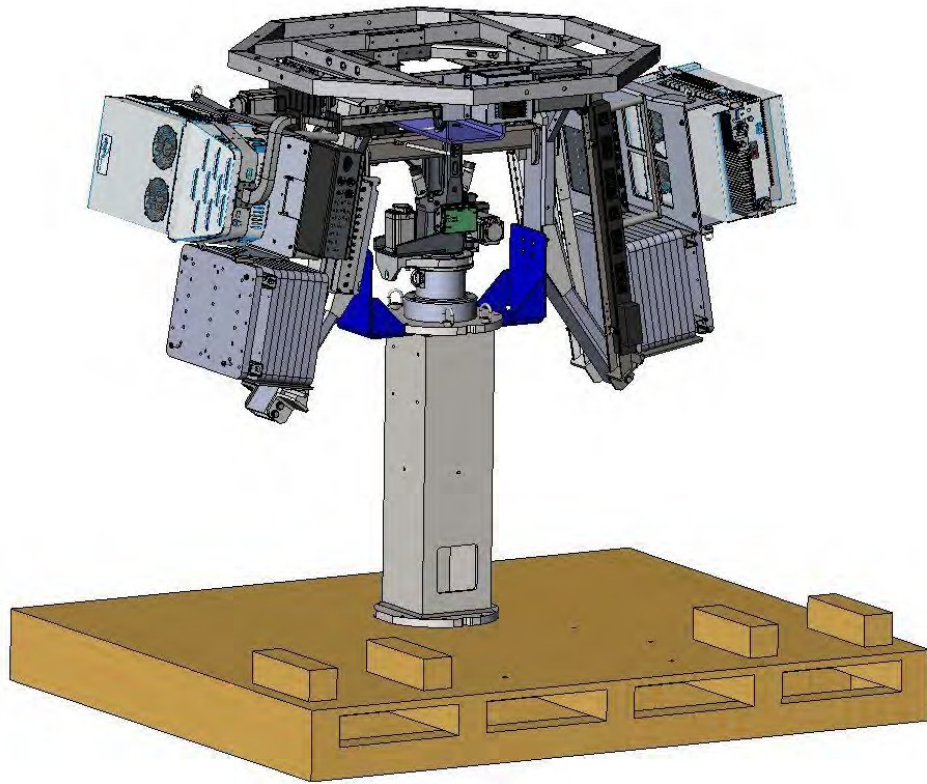

26. Remove the shipping hardware that mounts the Equipment Frame assembly to the pallet of the crate. Discard this hardware.

- 27. Using a suitably rated derrick or crane, lift the Equipment Frame assembly (approx. weight 2100lbs) up over the radome base section and suspend just above the middle post section.
- 28. Rotate the upper post to align the notch in its base to the notches in the middle and base pedestal sections.
- 29. Set the upper post section onto middle post section and assure that the notches remain aligned.
- 30. Apply Loctite to threads of the mounting bolts. Install the bolts & washers and tighten to torque spec.





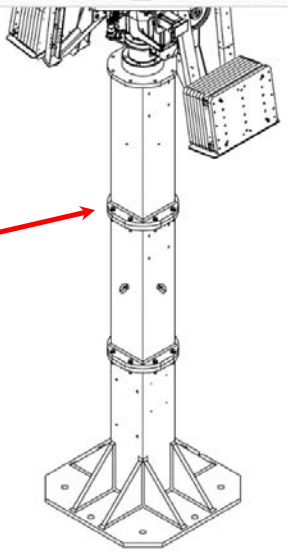

31. Remove the lifting spreader bracket installed in step 24 above.

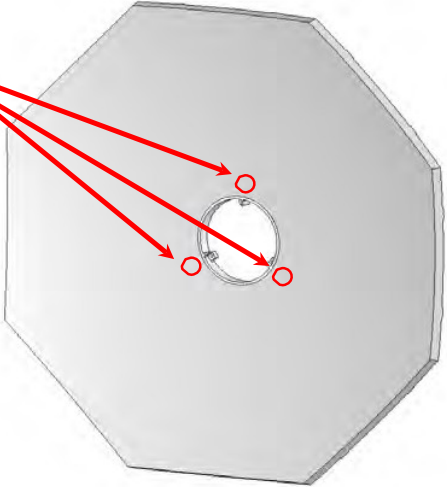
<p>32. There is a burnished 6mm threaded hole in the top side of the bottom plate of the middle post section.</p> <p>33. There is another burnished 6mm threaded hole in the under side of the top plate of the Base Stand post section.</p> <p>34. Apply Loctite to threads of 2 6mm bolts. Use the bolts & washers to install a ground strap around the mating of these to plates.</p> <p>35. Tighten the bolts torque spec.</p>	
--	--

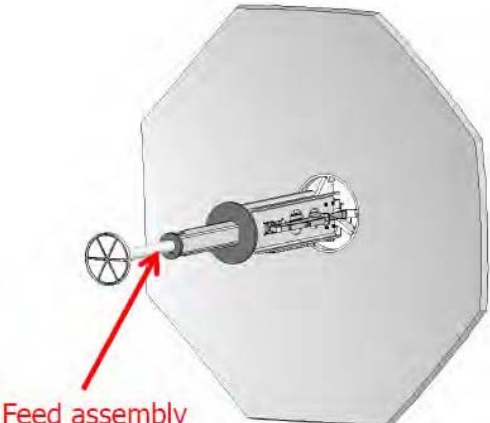
3.5. Assembling the Reflector

<ol style="list-style-type: none"> 1. Open the Reflector Hub and Feed crate. 2. Place the hub on raised platform (or crate) where the Reflector & feed can be assembled. 	
<p>NOTE: Shimming of feed to reflector hub may be needed. If so, shims will be provided and thickness(es) will be noted on reflector hub itself as shown.</p>	

<ol style="list-style-type: none">Lift reflector hub to vertical and hold.Apply Loctite to threads of the feed mounting bolts.Insert feed into hub (assure that someone is on the front side of the hub to gently hold the end of the feed).Orient the feed, installing shims (if needed), mounting bolts and washers.Tighten mounting bolts to torque spec.	 <p>Feed assembly</p>
<ol style="list-style-type: none">Set the hub/feed assembly (feed up) on 2 or 3 supports to hold it above the ground and protect the waveguide protruding from the bottom of the hub. <p>At Sea Tel, we used the empty BUC crates (see below).</p>	 <p>Waveguide</p>
<ol style="list-style-type: none">Reflector hub and petals are numbered 1-8. Install petals so both petal & hub numbers match up.	
	

10. Apply Loctite to threads of the reflector petal mounting bolts & washers.
11. Mount petal 1 using the petal mounting bolts & washers, but leave bolt slightly loose.
12. After mounting first petal, DO NOT mount adjacent petal as there is a potential for hub to tip over which can cause reflector damage or Installer injury.
13. Sea Tel recommends mounting opposing petals in the following order; 1 then 5, 3 then 7, 2 then 6 and last 4 then 8.
14. After all hardware is installed, tighten all hardware starting with one seam (ie petal 1 & 2) at the reflector hub, then each bolt out to out end of each petal joint. Tighten bolts to torque spec.
15. Repeat the previous step on the next seam. Continue with each subsequent seam until all mounting bolts have been tightened to torque spec.

3.6. *Installing the Reflector*

1. Install one reinforcement bracket on each seam leaving two bolts out every other bracket (To be used as Eye Nut mounting).



2. Install two 3/8-16 x 1-1/2" all thread in empty bracket holes. Install two lifting eye nuts on 4 out of 8 brackets.
3. Attach 4 equal length straps to lift antenna assembly. Make sure, straps are long enough to clear feed while lifting.







4. Install at least 2 additional long straps on 2 of the eye nuts to be used as tag lines. This will help to control the reflector in case of wind while hoisting.

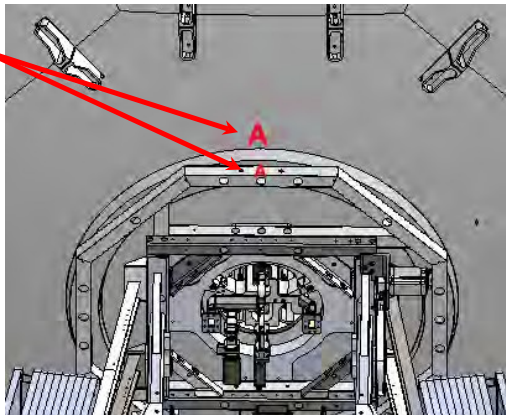

5. Using a suitably rated derrick or crane, lift the Antenna Assembly (approx. weight 870lbs) up over the radome base section and suspend just above the Equipment Frame assembly.

<p>6. Rotate the Antenna Assembly to align the letter on the back of the reflector to the letter on the reflector mounting brace.</p> <p>7. Set the Antenna Assembly down onto the reflector mounting brace aligning the mounting holes in each.</p> <p>8. Apply Loctite to threads of the mounting bolts. Install the bolts & washers and tighten to torque spec.</p>	
<p>9. Install one grounding strap from the interior of the equipment frame to the Feed.</p>	
<p>10. Connect the grounding strap to the Feed.</p>	
<p>11. Connect waveguides from the BUCs to the feed assembly.</p>	

3.7. Closing the Radome



1. Attach the 4-part lifting sling to the lifting straps around the base of the upper radome assembly (approx. 1500 lbs).
2. Attach at least 2 tag lines to 2 opposite lifting straps to control the upper radome assembly while it is hoisted.
3. Using a suitably rated derrick or crane, lift the upper radome assembly above the antenna assembly and move into position to set the upper radome assembly onto the radome base assembly.
4. Exercise extreme caution to assure that the upper radome assembly does not damage the feed tube or reflector as it is lowered down to within several inches of the top of the radome base section.
5. Rotate the upper radome assembly to align panel 401 to be in place directly above panel 501.
6. Continue lowering the upper radome assembly, while guiding it to be properly aligned with panel 401 centered directly atop panel 501 and suspended $\frac{1}{4}$ inch above the radome base section.
7. While holding the upper radome assembly suspended, loosely install the horizontal flange mounting bolts and washers. Apply Loctite to the exposed threads of the bolts, and with the flange slightly open apply a bead of caulking between the panels. Lower the upper radome assembly until it is sitting on the radome base section and tighten to torque spec the bolts. Wipe off the excess caulking from inside and outside of the horizontal panel flange mating.
8. Remove the 4-part lifting sling from the radome assembly.

3.8. Connections Into The ODU

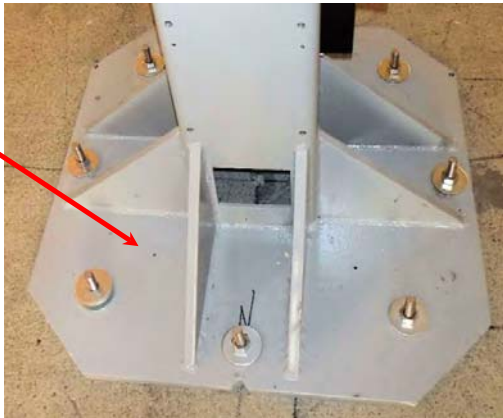
<ol style="list-style-type: none"> 1. Route Main AC Power (220 VAC, 30 Amps) into the radome to Circuit Breaker Box. 2. Route a ground cable or strap into the radome to Circuit Breaker Box. 3. Provide a cover over Power, Ground, IFL and any other cables that run across the cement from the edge of the radome to the antenna pedestal. The cover must protect the cables and assure that they are not a trip hazard. 	
<ol style="list-style-type: none"> 4. Route a ground cable or strap from the Circuit Breaker Box to one of the 6mm threaded holes in the top side of the base plate of the pedestal. 5. Apply Loctite to threads of a 6mm bolt. Install the bolt & washer and tighten to torque spec. 	
<ol style="list-style-type: none"> 6. Connect CFE IFL Run cables to the IF Interface & 10 MHz Distribution Assembly. 	

3.9. Installing Maintenance Mode Switch & Door Sensor

Refer to drawings;

93-164608-A_01 SCHEMATIC, DOOR MUTE SENSOR CIRCUIT

93-165834-A_01 SCHEMATIC MAINTENANCE MODE REMOTE CIRCUIT.

1. Mount the Maintenance Mode Switch and the Door Sensor in a convenient location near the radome door.
2. Route the interconnecting cables under the protective cover across the cement to the Safety circuit Interface Box.

3.10. Pedestal Interior Connections

Route the following wires/cables through the pedestal post sections refer to drawings

DL-162776-A SYSTEM BLOCK LIST, GLOBALSTAR TRACKER,

92-162776-A1_DMG_RE_M SYSTEM BLOCK DIAGRAM, GLOBALSTAR TRACKER

93-164211-A01 SCHEMATIC, TRACKER 6000 SYSTEM, GLOBALSTAR;

1. Route power & ground wires from the Power Ring through the post sections to the Circuit Breaker Box.
2. Route the coax cables from the Power Ring through the post sections to the IF Interface & 10 MHz Distribution Assembly.
3. Route Door Sensor wire from the Power Ring through the post sections to the Circuit Breaker Box.

3.11. *Installing Interior Lighting*

Refer to drawings:

92-162776-A1_DMG_RE_M SYSTEM BLOCK DIAGRAM, GLOBALSTAR TRACKER

93-164211-A01 SCHEMATIC, TRACKER 6000 SYSTEM, GLOBALSTAR

62-165842 RADOME LIGHTING KIT, T6000



1. Mount the Light Switch to radome near the radome hatch/door.
2. Route input power to the switch from the AC Power Strip.
3. Route power from the switch to the Power Supply.
4. Provide cover over the power cables to protect them and assure that they are not a trip hazard.
5. Mount Power Supply in a convenient location based on the length of the interconnecting cable from the Switch.
6. Mount the splitter in a convenient location based on the locations of the Power Supply and interconnecting cable.
7. Install the 6 interior lights on inner flanges of the radome, as desired, based on the location of the Splitter and the interconnecting cables.
8. Mount each light fixture to the inner flange.
9. Use cable ties to route and affix all of the interconnecting cables in place along the flanges.

3.12. *Remove the Service Brackets*

CAUTION; Do NOT remove the Service Brackets until all assembly work has been completed and you are ready to check mechanical rotation of the antenna or turn antenna power ON.

DANGER; Severe damage to the antenna or the assembly personnel can be caused by removing the Service Brackets until all work has been completed.

CAUTION; Do NOT turn antenna power ON until the Service Brackets have been removed.

Refer to drawing 62-167134 BRACKET KIT, SERVICE, T6000.

1. Assure that all personnel in the area are aware that the Service Brackets are being removed.
2. Remove the mounting hardware from the Service Brackets while maintaining control of the mechanism.
3. Store the Service Brackets, and the mounting hardware, in a secure location where they can be used again whenever the antenna is being stowed (immobilized).



4. Assure that the ODU/Antenna is ready to be energized.
5. If power to the ODU was "tagged out", remove the tag from the breaker that supplies power to the ODU.
6. If power to the Antenna from the Circuit Breaker Box was "tagged out", remove the tag from the breaker that supplies power to the Antenna.
7. When all nearby personnel are ready, turn power breaker ON.
8. Start, or return to, normal service.

3.13. Final Checks

Remove all tools, parts and installation debris from inside the radome.

Remove all tools, parts and installation debris from the area around the outside of the radome.

4. Setup & Testing

To setup IP addresses, adjust, align or test the antenna and all of the equipment mounted on it, please refer to document 99-169239-A Procedure, Test, Product, Tracker 6000 Site Test at the end of the drawings section of this manual.

The scope of this test procedure is use to validate the Tracker 6000 antenna system after the system has been built and integrated at the installation site. It is not intended to be a step-by-step instruction to guide the individual on how to connect, setup, and test the product. The Technician or Engineer using this procedure to validate the antenna should have knowledge of the antenna system, basic PC communication, and use of test equipment.

There are some specific Aps/programs required to accomplish this procedure. They will be provided on the USB with all of the other documentation.

The IMA GUI (through the ICU mounted on the antenna) is only used for commissioning and troubleshooting and **it is required to be disabled for normal operation.**

The SNMP GUI may be used as another way to control and check status of the antenna;

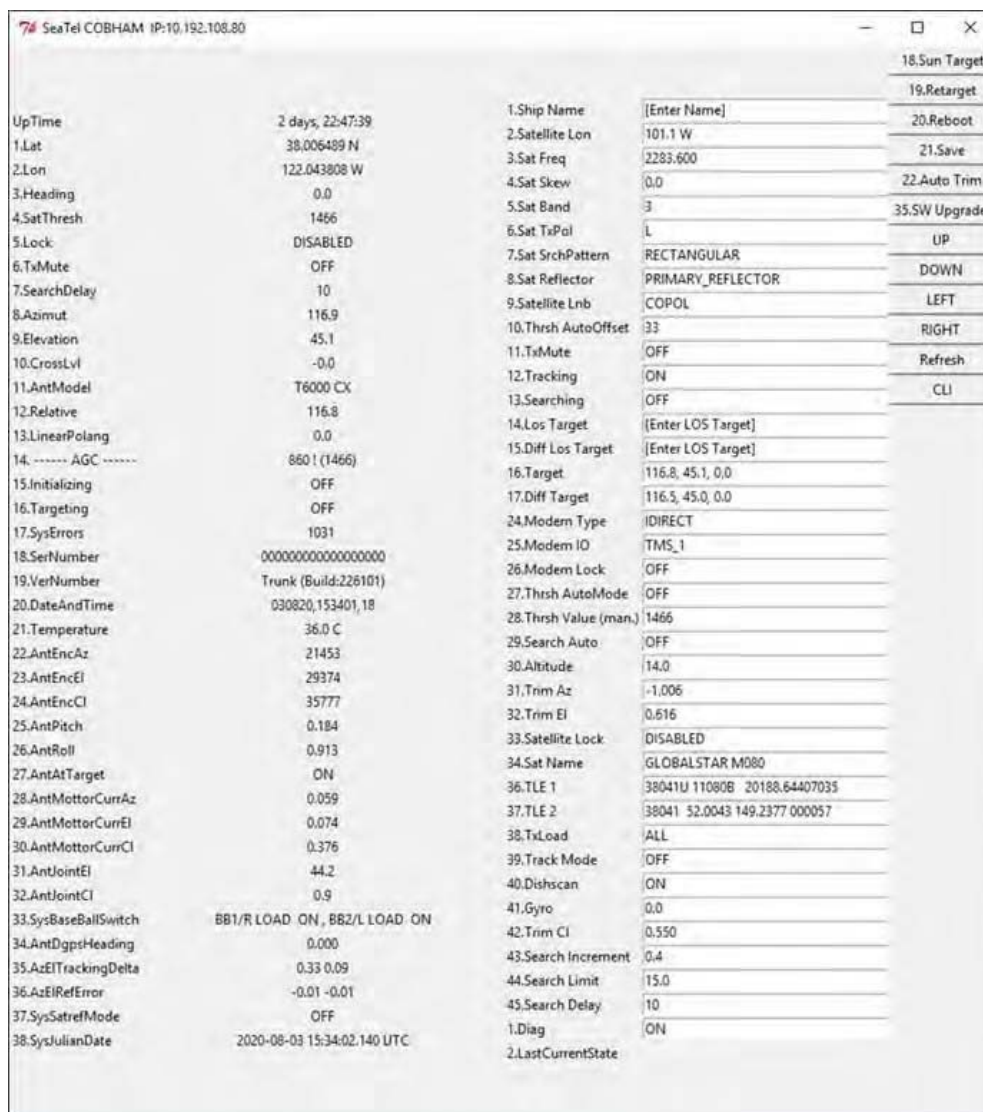

This Page Intentionally Left Blank

5. Maintenance

This section describes the maintenance procedures for this antenna system.



WARNING: *Electrical Hazard—Dangerous AC Voltages exist in the Circuit Breaker Box mounted on the pedestal post. Observe proper safety precautions when working inside the Antenna Breaker Box.*

5.1. Safety

Service

Access to the interior of the Out Door Unit (ODU), is allowed for inspection of components by a technician/engineer. Maintenance of the ODU should only be performed by technicians/engineers who are authorized by Cobham SATCOM. Only authorized Partners who have received factory training on this equipment will be able to file a claim for warranty reimbursement. Failure to comply with standard practices, which include but are not limited to modification of the terminal away from factory documented assemblies may also void the warranty period.

Do not service or adjust alone

Do not attempt internal service or adjustments unless another person, capable of rendering first aid resuscitation, is present.

Personal Protection Equipment (PPE):

Hard hat, safety glasses and steel toe work boots are required.

To avoid injuries, it is important to be aware of the risks present when handling and testing an antenna from inside the dome. There is a risk of the antenna injuring the operator, as the antenna moves, so the operator must be aware of the position of the antenna at all times while inside the radome.

Keep away from live circuits

Operating personnel must not remove equipment covers. Component replacement and internal adjustment must be made by qualified maintenance personnel. Do not replace components with the power cable connected. Under certain conditions, dangerous voltages may exist even with the power cable removed. To avoid injuries, always disconnect power and discharge circuits before touching them.

5.2. Warranty Information

Sea Tel Inc. supports these systems with a **TWO** year warranty on parts and labor.

Access to the interior of the Outdoor Equipment (ODE), is allowed for inspection of components as described in the Scheduled Inspections section of this manual may be accomplished by technician/an engineer. Maintenance of the ODE should only be performed by technicians/engineers who are authorized by Cobham SATCOM. Only authorized Partners who have received factory training on this equipment will be able to file a claim for warranty reimbursement. Failure to comply with standard practices, which include but are not limited to modification of the terminal away from factory documented assemblies may also void the warranty period.

What's Covered by the Limited Warranty?

The Sea Tel Limited Warranty is applicable for parts and labor coverage to the complete antenna system, including all ADE (radome, pedestal, antenna, motors, electronics, wiring, etc.) and the ACU or MXP.

What's NOT Covered by the Limited Warranty?

It does not include Transmit & Receive RF Equipment, Modems, Multiplexers or other distribution equipment, whether or not supplied by Sea Tel commonly used in Satellite Communications (TXRX)



Systems. These equipments are covered by the applicable warranties of the respective manufacturers.

Original installation of the system must be accomplished by, or under the supervision of, an authorized Sea Tel dealer for the Sea Tel Limited Warranty to be valid and in force.

Should technical assistance be required to repair your system, the first contact should be to the agent/dealer you purchased the equipment from.

Please refer to the complete warranty information included with your system.

5.3. Torque and Loctite Specifications

	<p>WARNING: Assure that all nut and bolt assemblies are tightened according to the tightening torque values listed below:</p>																				
	<table border="1"> <thead> <tr> <th>SAE Bolt Size</th> <th>Inch Pounds</th> <th>Metric Bolt Size</th> <th>Kg-cm</th> </tr> </thead> <tbody> <tr> <td>1/4-20</td> <td>75</td> <td>M6</td> <td>75.3</td> </tr> <tr> <td>5/16-18</td> <td>132</td> <td>M8</td> <td>150</td> </tr> <tr> <td>3/8-16</td> <td>236</td> <td>M10</td> <td>270</td> </tr> <tr> <td>1/2-13</td> <td>517</td> <td>M12</td> <td>430</td> </tr> </tbody> </table>	SAE Bolt Size	Inch Pounds	Metric Bolt Size	Kg-cm	1/4-20	75	M6	75.3	5/16-18	132	M8	150	3/8-16	236	M10	270	1/2-13	517	M12	430
SAE Bolt Size	Inch Pounds	Metric Bolt Size	Kg-cm																		
1/4-20	75	M6	75.3																		
5/16-18	132	M8	150																		
3/8-16	236	M10	270																		
1/2-13	517	M12	430																		
	<p>NOTE: All nuts and bolts should be assembled using the appropriate Loctite thread-locker product number for the thread size of the hardware.</p> <table border="1"> <thead> <tr> <th>Loctite #</th> <th>Description</th> </tr> </thead> <tbody> <tr> <td>222</td> <td>Low strength for small fasteners.</td> </tr> <tr> <td>242</td> <td>Medium strength</td> </tr> <tr> <td>638</td> <td>High strength for Motor Shafts & Sprockets.</td> </tr> <tr> <td>2760</td> <td>Permanent strength for up to 1" diameter fasteners.</td> </tr> <tr> <td>290</td> <td>Wicking, High strength for fasteners which are already assembled.</td> </tr> </tbody> </table>	Loctite #	Description	222	Low strength for small fasteners.	242	Medium strength	638	High strength for Motor Shafts & Sprockets.	2760	Permanent strength for up to 1" diameter fasteners.	290	Wicking, High strength for fasteners which are already assembled.								
Loctite #	Description																				
222	Low strength for small fasteners.																				
242	Medium strength																				
638	High strength for Motor Shafts & Sprockets.																				
2760	Permanent strength for up to 1" diameter fasteners.																				
290	Wicking, High strength for fasteners which are already assembled.																				

5.4. Balancing the Antenna

The elevation and cross-level motors have a brake mechanism built into them, therefore, **power** must be ON to release the brakes and **DishScan® and antenna drive** must be OFF to balance the antenna. . **Do NOT remove any of the drive belts.** Balancing is accomplished by adding or removing balance trim weights at strategic locations to keep the antenna from falling forward/backward or side to side. The antenna system is not pendulous so 'balanced' is defined as the antenna remaining at rest when left in any position.

The "**Balance Mode**" selection located on the upper part of the "**Four Quadrant Test**" screen in the **Tools – Test** menu page. When enabled, Balance Mode temporarily turns DishScan®, Azimuth, Elevation and Cross-Level drive OFF. This function is required when trying to balance this antenna system.

Assure that Antenna power is ON and that the antenna has completed initialization.

At the Computer:

1. Log into the GUI, select Tools - Test in the side bar menus.
2. Select "**Balance Mode**" to enable balance mode. The screen will then show ON & OFF buttons.
3. Click ON. The screen will temporarily display "Submitting ... Please Wait". When this message disappears the antenna is in balance mode. **DO NOT EXIT THIS SCREEN.**

At the Antenna:

4. At the Antenna: Balance the antenna with the elevation near horizon (referred to as front to back balance) **by adding, or subtracting, small counter-weights.**
5. Then balance Cross Level axis (referred to as left-right balance) **by moving existing counter-weights from the left to the right or from the right to the left.** Always move weight from one location on the equipment frame to the same location on the opposite side of the equipment frame (ie from the top left of the reflector mounting frame to the top right of the reflector mounting frame). Do NOT add counter-weight during this step.
6. Last, balance the antenna with the elevation pointed at, or near, zenith (referred to as top to bottom balance) **by moving existing counter-weights from the top to the bottom or from the bottom to the top.** Always move weight from one location on the equipment frame to the same location on the opposite side of the equipment frame (ie from the top left of the reflector mounting frame to the bottom left of the reflector mounting frame). Do NOT add counter-weight during this step.
7. When completed, the antenna will stay at any position it is pointed in for at least 5 minutes.
8. ***Do NOT cycle antenna power to re-Initialize the antenna.*** which is still in Balance Mode. Click OFF. The screen will temporarily display "Submitting ... Please Wait". When this message disappears the antenna is in normal operation mode. When you exit Balance Mode the antenna will return to normal (DishScan®, Azimuth, Elevation and Cross-Level drive ON).

This Page Intentionally Left Blank

6. Stowing the Antenna

This antenna must be properly stowed if the antenna will need to be immobilized for service or to remove it from service.

Refer to drawing 62-167134 BRACKET KIT, SERVICE, T6000.

6.1. *Installing the Service Brackets*

CAUTION; Do NOT remove the "tagged out" tag, or turn power breaker ON, until the Service Brackets have been removed and all personnel are ready for the antenna to be energized.

1. Assure that the ODU/Antenna is ready to be de-energized/taken out of service.
2. Locate the Service Brackets and mounting hardware from their storage location.
3. If power to the ODU is being secured, turn the breaker OFF and tie a "Tag Out" tag to the breaker that supplies power to the ODU.
4. If power to only the Antenna is being secured, turn the breaker OFF and tie a "Tag Out" tag to the breaker that supplies power to the Antenna inside the Circuit Breaker Box.

5. Assure that all personnel in the area are aware that the Service Brackets are being installed.
6. Rotate the antenna Elevation up to zenith (90).
7. Rotate the antenna Azimuth to be centered at the notch in the upper plate of the post.
8. Install the bolts, washers and hex nuts.
9. Tighten mounting bolts to torque spec.



6.2. *Remove the Service Brackets*

CAUTION; Do NOT remove the Service Brackets until all assembly/service work has been completed and you are ready to check mechanical rotation of the antenna and turn antenna power ON.

DANGER: Severe damage to the antenna, or the assembly/service personnel, can be caused by removing the Service Brackets before all work has been completed and you are ready for the antenna to be un-restrained.

CAUTION; Do NOT turn antenna power ON until the Service Brackets have been removed.

Refer to drawing 62-167134 BRACKET KIT, SERVICE, T6000.

10. Assure that all personnel in the area are aware that the Service Brackets are being removed.
11. Remove the mounting hardware from the Service Brackets while maintaining control of the mechanism.
12. Store the Service Brackets, and the mounting hardware, in a secure location where they can be used again whenever the antenna is being stowed (immobilized).



13. Assure that the ODU/Antenna is ready to be energized.
14. If power to the ODU was "tagged out", remove the tag from the breaker that supplies power to the ODU.
15. If power to the Antenna from the Circuit Breaker Box was "tagged out", remove the tag from the breaker that supplies power to the Antenna.
16. When all nearby personnel are ready, turn power breaker ON.
17. Start, or return to, normal service.

7. Tracker 6000 Technical Specifications

The technical specifications for your Series Above Decks Equipment subsystems are listed below: Refer to your ACU manual for its' Specifications.

7.1. *Out Door Unit (ODU)*

System Weight (ADE)	
Weight	2732.2 kg (6023.8 lbs) with 8 m Radome
Stabilized Antenna Pedestal Assembly	
Type	Three-axis (Level, Cross Level and Azimuth)
Pointing	Torque Mode Servo
Azimuth, Level, Cross Level Motors	Size 34 FOV Controlled Step motors operating in Torque Mode
Inertial Reference	3 Axis Solid State Rate Sensors
Gravity Reference	3 Axis Solid State Accelerometers
AZ transducer	16 Bit Absolute Encoder
Pointing Accuracy (Open Loop)	0.5 degrees
Pointing Accuracy (Closed Loop)	0.05 degrees (0.02 degrees Typ)
Pedestal Range of Motion:	
Elevation Joint Angle	0 to + 180 degrees
Cross Level	+/- 15 degrees
Azimuth	700 Degrees (+/- 270 nominal)
Elevation Pointing	5 to + 175 degrees
Tracking modes	Dishscan (Autotrack), Program Track (TLE, ECEF)
Antenna Reflector	
Type	Prime Focus, Parabola (1 Hub & 8 Petals)
Diameter	6 M (146 in)
Frequency TX	5.091 - 5.24912 GHz
Frequency RX	6.875-7.055 GHz
Size	6 m (19.685 ft)
Gain TX	47.3 dB
Gain RX	49.4 dB
Pattern Mask	FCC 25.209
Mask start point	1.5 degrees
Axial	25 degrees
G/T C- band	12 dBk / 24 dBk

Feed - S-Band (TXRX) / X-Band (RX)	
4-Port OMT	
Frequency TX	5.091 - 5.24912 GHz
Frequency RX	6.875-7.055 GHz
Polarization	LHCP/RHCP
VSWR	<1.3:1
Interface Antenna	Circular
Tx to RX isolation	>50 dB
LHCP to RHCP isolation	>20 dB
Polarization Control	TX/RX & RHCP/LHCP remotely selectable
C-band TX Radio Package	
SSPB	From IBUC R 300W Globalstar
Input	
Input Connector	Type N female (50 Ohm)
VSWR / Impedance	1.4:1 max / 50 Ohm
Input power detector range	-30 to 5 dBm
Max input level with no damage:	+10 dBm
Gain	
Small Signal Gain (L-band to RF) with attenuator set to 0 dB	(300W) 61 dB min
Attenuator range	30 dB in 0.1 dB steps
Gain flatness Full band	2 dB p-p max
Gain variation over temperature Band 6	
Open loop	2 dB p-p max
with AGC	1 dB p-p max
RF Output	
Output Flange	CPR-159G
RF Output Frequency Range	5.090-5.2505 GHz
RF Output VSWR	1.3:1
RF Output Power (Psat)	(300W) +54.8 dBm typ @ 25°C
Output power (at minimum of 16 dB NPR):	125W min
IMD3 (2 carriers, @ 125W Total Power)	-27 dBc max
Level stability with ALC	+0.5 dB
Output power detector range	Rated power to -20 dB
Power reading accuracy	+ 1.0 dB max.
Spurious	
In Band	-60 dBc @ 4kHz RBW (carrier related) -25 dBm (fixed)
Out of Band	-45 dBm
Harmonics	-50 dBc max.

Output Noise Power Density	
TX Band	< -74 dBm/Hz
RX (6800-7100 MHz)	< -125 dBm/Hz
SSB Phase IBUC R	
100 Hz	-60 dBc/Hz
1 kHz	-70 dBc/Hz
10 kHz	-85 dBc/Hz
100 kHz	-105 dBc/Hz
1 MHz	-120 dBc/Hz
External Reference	
Reference Frequency Level	-12 to +5 dBm
Reference Frequency	10 MHz external (multiplexed on TX IFL). Internal 10 MHz optional
PLL Acquisition Range:	9,999,980-10,000,020 Hz
Local Oscillator Frequency	
Non-inverting	(Band 6) 4250 MHz
IBUC Power Supply	200 to 240 VAC
Power Consumption	(300W), 2000 VA
Monitor and Control	Ethernet (HTTP, Telnet, SNMP), via RJ45 connector, RS232/485, Hand-held Terminal via MS-type connector, FSK multiplexed on TX
Environmental	
Operating temperature	-40°C to +55°C
Relative humidity	100% condensing
Altitude	10,000 ft (3,000 m) ASL
LNB C-Band (RX)	
RF Frequency:	6.875-7.055 GHz
LO Frequency:	9.160 GHz
IF Frequency:	L-Band RX Output
Reference:	external 10 MHz reference
Gain	60 dB Min.
Gain flatness:	±0.5 dB
Gain stability:	0.5 dB at stable temperature
Noise Figure:	0.8 dB Max. Target 0.7 dB.
Input Connector:	WR112 UG
VSWR input:	1.5:1 max. Target 1.3:1
RF input:	0 dBm (Survivable)
Image rejection etc.:	50 dB min.
1 dB Compression point	+10 dBm
Output IP3	+20 dBm
Output connector:	N female (50 ohm)
Power:	+12 to +24VDC

Waveguide Notch Filter – BSC WB 13310	
Passband From	5096.96MHz to 5249.12MHz
Insertion Loss at Bandedges	2dB max
Passband Return Loss	16dB min
Rejection from 5091MHz to 5092MHz	25dB min
Maximum Power Handling over passband	5W Peak
Dimensions excluding connectors	360 x 80 x 60 mm typical
Input Connector	SMA Female
Output Connector	SMA Female
Operating Temperature Range	-20°C to 60°C
External Finish	Matt Black
Waveguide Bandpass Filter – BSC WB 13311	
Passband From	5091MHz to 5092MHz
Insertion Loss at Bandedges	4dB max
Passband Return Loss	16dB min
Rejection from 5096.96MHz to 5249.12MHz	25dB min
Maximum Power Handling over passband	5W Peak
Dimensions excluding connectors	360 x 60 x 40 mm typical
Input Connector	SMA Female
Output Connector	SMA Female
Operating Temperature Range	-20°C to 60°C
External Finish	Matt Black
Waveguide Bandpass Filter – BSC WB 12832	
Passband From	6875MHz to 7055MHz
Insertion Loss at Bandedges	0.65dB max
Insertion Loss at Bandedges	0.4dB typical
Passband Return Loss	18dB min
Rejection from 1000MHz to 6725MHz	60dB min
Rejection from 1000MHz to 6725MHz	65dB typical
Rejection from 7200MHz to 11700MHz	50dB min
Rejection from 7200MHz to 11700MHz	55dB typical
Maximum Power Handling over passband	500W CW
Dimensions excluding connectors	To customer drawing 46-163106, 11/02/2018, note 1)
Input Connector	PBR84 (UG52/U)
Output Connector	PBR84 (UG52/U)
Operating Temperature Range	-10°C to 50°C
External Finish	To customer drawing 46-163106, 11/02/2018, note 2)

Waveguide Bandpass Filter – BSC WB 12833	
Passband From	5080MHz to 5260MHz
Insertion Loss at Bandedges	0.55dB max
Insertion Loss at Bandedges	0.45dB typical
Passband Return Loss	18dB min
Rejection from 1000MHz to 4925MHz	55dB min
Rejection from 5375MHz to 8500MHz	65dB min
Maximum Power Handling over passband	1000W CW
Dimensions excluding connectors	To customer drawing 46-163106, 11/02/2018, note 1)
Input Connector	CPRF159
Output Connector	CPRG159
Dimensions excluding connectors	360 x 60 x 40 mm typical
Input Connector	SMA Female
Output Connector	SMA Female
Operating Temperature Range	-10°C to 50°C
External Finish	To customer drawing 46-163006, 11/02/2018, note 2)
GPS (On Board)	
Waterproof	IPX7
Operating Temperature	-30°C to +60°C
Storage Temperature	-40°C to +60°C
Altitude	-304m to 18,000m`
Vibration	IEC 68-2-64
Shock	50G Peak, 11ms
Connector	RJ11
Input Voltage	
Min	4.75VDC
Typ	5.0VDC
Max	5.25VDC
NMEA output messages	GGA, GLL
Refresh Rate	1s

Integrated Control Unit (ICU3)	
Connectors I/O Ports	
J1	SMA (F) - RXIF Input from LNB 1
J2	SMA (F) - RXIF Input from LNB 2
J3	SMA (F) - L-Band RXIF + EOC To Rotary Joint
J4 B/A	Ethernet - RJ45, RF Serial M&C - A=Radio M&C, B=Pass through
J5 B/A	Ethernet - RJ45, RF Serial M&C - A=Radio M&C, B=Pass through
J6 A/B	DE-9S - Network - C, Console Serial M&C
J7 A/B	DE-9S - Ethernet Ports
J8	DE-9S - GPS Antenna Input
J9	Mini USB
J10	DB-15S - Motor Control
J11A	DB-25S C-Band Waveguide Switch, LHCP and RHCP
J11B	DB-25S Ku-Network Sub-reflector Control
J20	DE-15S - Power Relay Control
J21	DE-9P Remote Motion Platform
J27	DB-25S - Maintenance Mode and iBUC2 Mute Monitor
J28	DE-9P - GPS
J29	DA-15S - AZ Encoder and FDM module Interface
Coaxial Switches	
J31	N/C
J32	N/C
J33	N/C
J34	N/C
J41	N/C
J42	N/C
J43	N/C
J44	N/C
J51	L-Band Switch Rotary Joint J3, Not use
J52	N/C
J53	N/C
J54	N/C
Status LEDs	Diagnostic Status of the EoC
	Diagnostic Status of the ICU
AC Input Power	85-264 VAC, 47-63Hz, single phase, 4A-3A
Controls	Configurable from GUI

Integrated SCPC Receiver	
Tuning Range	950 to 2150 MHz , 600 to 2200 MHz available.
Input RF Level	-85 to -25dBm typical
Output RF Level	Input level +/- 1dB typical
Sensitivity	30mV/dB typical (25 counts/dB typical)
Bandwidth (3dB)	256KHz, 128KHz, and 64KHz
Integrated DVB-S2 Receiver	
DVB-S2 Compliant	
Tuning Range	950 to 2150 MHz , 600 to 2200 MHz available.
Input RF Level	-85 to -25dBm typical
Output RF Level	Input level +/- 1dB typical
Sensitivity	30mV/dB typical (25 counts/dB typical)
Bandwidth (3dB)	7.5~30MHz adjustable
Interfaces	
Modem M&C Interface	OpenAMIP & Legacy
Network Interface	4-port managed fast ethernet switch
User Interface	Web Browser/Console Port
Motor Driver Enclosure FDM	
Connectors	
Motor Driver- S-Bus IN J1000	DE-9P
Motor Driver- S-Bus OUT J1001	DE-9S
AZ Motor (J501)	MICRO-FIT-4P
AZ Encoder (J504)	MILLI-GRID-10P to D-SUB
EL Motor (J503)	MICRO-FIT-4P
EL Encoder (J506)	MILLI-GRID-10P to D-SUB
CL Motor (J502)	MICRO-FIT-4P
CL Encoder (J505)	MILLI-GRID-10P to D-SUB
Status LEDs	
Power ON	Green
FDM Status	Green, Flashing Green, Red, Flashing Red, Orange
MDE Status	Yes
ADE-BDE Interface Connections	
IFL Module	4 ch, L Band TXIF_LHCP, TXIF_RHCP,RXIF_LHCP, RXIF_RHCP
Insertion Loss	<3.0 dB
Interface	N type coax
Power Requirements	
Input Power	200-264 VAC, 47-63Hz, single phase.
Antenna System Power Consumption	4915 VA
Air Conditioner Power Consumption	MILSAT Responsibility

8 m Radome Assembly	
Type	Frequency Tuned C-Band
Material	Proprietary composite foam/laminate
Shape	Modified/truncated Sphere
Materials	Proprietary A sandwich
Size	
Diameter	8 m (26.25 ft)
Height - Radome Only	745.0 cm (293.3 inch)
Height - Radome with Hazard Light / Lightning Spike	889.35 cm (350.12 inch)
Side Door Opening	WxH 86 cm x 126 cm [33.8 x 49.6 inch], with 15 cm/6 inch stepover height.
Number of panels	12 Lower, 12 Middle Lower, 12 Middle Upper, 12 Upper & 1 Top Cap
Installed weight	See system weight above.
RF attenuation	<0.35 dB
Wind:	Withstand relative average winds up to 201 Kmph (125 mph) from any direction.
Ingress Protection Rating	IP 56
Hazard Light & Lightning Spike	
Height	144.35 cm (56.82 inch)
Foundation	
Mounting	Contract grade cement pad
Mechanical Alignment leveling	not required
Mechanical Alignment pointing	not required
ADE Environmental Conditions	
Operating Temperature	-40 to 55 °C
Non-operating Temperature	-40 to 60 °C
Humidity	0% to 100% Condensation

7.2. *Regulatory Compliance*

Survival Shock and Vibration	NA
Operational Shock and Vibration	NA
Safety	IEC 60950
EMI/EMC Compliance	ETSI EN 301 489-1 V1.4.1 (2002-08)
	ETSI EN 300 339 (1998-03)
Satellite Earth Stations and System (SES)	NA
Safety Compliance	IEC EN 60950-1:2001 (1st Edition)
Environmental Compliance	RoHS
	Green Passport
Lightning /Surge Protection	IEC 61643-1, IEC 6143-12 & NFPA-780