

Prüfbericht-Nr.: <i>Test Report No.:</i>	50103731 001	Auftrags-Nr.: <i>Order No.:</i>	114068828	Seite 1 von 17 <i>Page 1 of 17</i>
Kunden-Referenz-Nr.: <i>Client Reference No.:</i>	N/A	Auftragsdatum: <i>Order date:</i>	31-Aug-2017	
Auftraggeber: <i>Client:</i>	Microchip Technology Inc., 2355 West Chandler Blvd. Chandler, Arizona 85224-6199, United States.			
Prüfgegenstand: <i>Test item:</i>	IEEE 802.11 b/g/n Network Controller Module With Integrated Bluetooth 4.0 (BLE)			
Bezeichnung / Typ-Nr.: <i>Identification / Type No.:</i>	ATWINC3400-MR210CA			
Auftrags-Inhalt: <i>Order content:</i>	FCC Part 15C / IC RSS-247 (Class II Permissive Change) Test report (WiFi 2.4GHz) spurious radiated emissions only			
Prüfgrundlage: <i>Test specification:</i>	FCC 47CFR Part 15: Subpart C Section 15.247 RSS-247 (05-2015)			
Wareneingangsdatum: <i>Date of receipt:</i>	18-Sep-2017			
Prüfmuster-Nr.: <i>Test sample No.:</i>	A000632215-002			
Prüfzeitraum: <i>Testing period:</i>	30-Sep-2017 - 30-Sep-2017			
Ort der Prüfung: <i>Place of testing:</i>	EMC Laboratory Taipei			
Prüflaboratorium: <i>Testing laboratory:</i>	TUV Rheinland Taiwan Ltd.			
Prüfergebnis*: <i>Test result*:</i>	Pass			
geprüft von / tested by:			kontrolliert von / reviewed by:	
12-Oct-2017	Jack Chang /Project Manager		12-Oct-2017	Arvin Ho/Vice General Manager
Datum	Name / Stellung	Unterschrift	Datum	Name / Stellung
<i>Date</i>	<i>Name / Position</i>	<i>Signature</i>	<i>Date</i>	<i>Name / Position</i>
Sonstiges / Other:	Reference the Test Report D50616R1 and D50908R3 of Compatible Electronics Inc.			
Zustand des Prüfgegenstandes bei Anlieferung: <i>Condition of the test item at delivery:</i>	Prüfmuster vollständig und unbeschädigt <i>Test item complete and undamaged</i>			
* Legende:	1 = sehr gut	2 = gut	3 = befriedigend	4 = ausreichend
	5 = mangelhaft	P(ass) = entspricht o.g. Prüfgrundlage(n)	F(ail) = entspricht nicht o.g. Prüfgrundlage(n)	N/A = nicht anwendbar
Legend:	1 = very good	2 = good	3 = satisfactory	4 = sufficient
	5 = poor	P(ass) = passed a.m. test specification(s)	F(ail) = failed a.m. test specification(s)	N/A = not applicable
				N/T = nicht getestet
				N/T = not tested
Dieser Prüfbericht bezieht sich nur auf das o.g. Prüfmuster und darf ohne Genehmigung der Prüfstelle nicht auszugsweise vervielfältigt werden. Dieser Bericht berechtigt nicht zur Verwendung eines Prüfzeichens.				
<i>This test report only relates to the a. m. test sample. Without permission of the test center this test report is not permitted to be duplicated in extracts. This test report does not entitle to carry any test mark.</i>				

TEST SUMMARY

5.1.1 SPURIOUS EMISSION

RESULT: Passed

Contents

1.	GENERAL REMARKS	4
1.1	COMPLEMENTARY MATERIALS.....	4
2.	TEST SITES	5
2.1	TEST LABORATORY	5
2.2	TEST FACILITIES	5
2.3	LIST OF TEST AND MEASUREMENT INSTRUMENTS.....	6
2.4	TRACEABILITY	7
2.5	CALIBRATION	7
2.6	MEASUREMENT UNCERTAINTY	7
3.	GENERAL PRODUCT INFORMATION.....	8
3.1	PRODUCT FUNCTION AND INTENDED USE	8
3.2	SYSTEM DETAILS AND RATINGS.....	8
3.3	INDEPENDENT OPERATION MODES.....	9
3.4	NOISE GENERATING AND NOISE SUPPRESSING PARTS	9
3.5	SUBMITTED DOCUMENTS.....	9
4.	TEST SET-UP AND OPERATION MODES.....	10
4.1	PRINCIPLE OF CONFIGURATION SELECTION	10
4.2	TEST OPERATION AND TEST SOFTWARE.....	10
4.3	SPECIAL ACCESSORIES AND AUXILIARY EQUIPMENT	11
4.4	COUNTERMEASURES TO ACHIEVE EMC COMPLIANCE.....	11
4.5	TEST SETUP DIAGRAM	11
5.	TEST RESULTS	13
5.1	TRANSMITTER REQUIREMENT & TEST SUITES	13
5.1.1	Spurious Emission	14
6.	PHOTOGRAPHS OF THE TEST SET-UP.....	14
7.	LIST OF TABLES	17
8.	LIST OF PHOTOGRAPHS.....	17

1. General Remarks

1.1 Complementary Materials

The following attachments are integral parts of this test report:

Appendix P: Photo Documentation
(File Name: 50103731APPENDIX P)

Appendix D: Test Result of Radiated Emissions
(File Name: 50103731APPENDIX D)

Test Specifications

The following standards were applied (in bold: product standards, otherwise: basic standards).

Table 1: Applied Standard and Test Levels

Radio
FCC CFR47 Part 15: Subpart C Section 15.247
RSS-247 Issue 1 May 2015
RSS-Gen, Issue 4, November 2014
ANSI C63.10:2013
KDB558074 D01 DTS Meas Guidance v03r05

2. Test Sites

2.1 Test Laboratory

TUV Rheinland Taiwan Ltd.
Taichung Branch Office

No.9, Lane 36, Minsheng Rd., Sec. 3, Daya District,
Taichung City 428
Taiwan (R.O.C.)

2.2 Test Facilities

TUV Rheinland Taiwan Ltd.
Taipei Office

11F. No.758, Sec. 4, Bade Rd., Songshan Dist.
Taipei City 105
Taiwan (R.O.C.)

FCC RegistrationNo.: 365730
IC Canada Registration No.: 9465A-1
TAF Accredited NCC Test Lab. No.:0759
TAF ISO17025 Certification effective periods: 2016-Jul-1st to 2019-Jun-30th



Testing Laboratory
0759

2.3 List of Test and Measurement Instruments

Table 2: List of Test and Measurement Equipment

Kind of Equipment	Manu-facturer	Type	S/N	Last Calibration	Next Calibration
Test Software	Farad	EZ_EMC	Ver. TUV3A1	N/A	N/A
EMI Test Receiver	R&S	ESR7	101062	2017/09/25	2018/09/25
Spectrum Analyzer	R&S	FSV 40	100921	2017/05/02	2018/05/02
Spectrum Analyzer	Agilent	N9010A	MY53470241	2017/05/23	2018/05/23
Preamplifier (30MHz -1GHz)	HP	8447D	2944A06641	2016/12/28	2017/12/28
Preamplifier (18 GHz -40 GHz)	COM-POWER	PAM-840	461257	2016/12/01	2017/12/01
Pre-Amplifier (1GHz~18GHz)	EM Electronics	EM01G18G	060558	2016/11/17	2017/11/17
Bilog Antenna	TESEQ	CBL6111D	29802	2017/07/12	2018/07/12
Horn Antenna	ETS-Lindgren	3117	138160	2017/05/25	2018/05/25
Horn Antenna (18GHz~40GHz)	COM-POWER	AH840	101031	2016/11/22	2017/11/22
Loop Antenna	Schwarzbeck	FMZB 1513	1513-076	2017/06/14	2018/06/14
EMI Test Receiver	R&S	ESC17	100797	2016/12/30	2017/12/30
Spectrum Analyzer	R&S	FSV-40	100921	2017/05/02	2018/05/02
Temp. & Humid. Chamber	WISEWIND	1509	509Q24R	2017/05/24	2018/05/24
LISN (1 phase)	R&S	ENV216	101243	2017/05/24	2018/05/24
LISN	R&S	ENV216	101262	2017/06/22	2018/06/22
Test Software	Audix	e3	Ver. 9	N/A	N/A
Power sensor	Agilent	U2021XA	MY54020001	2017/01/08	2018/01/08

2.4 Traceability

All measurement equipment calibrations are traceable to NML(Taiwan)/NIST(USA) or where calibration is performed outside Taiwan, to equivalent nationally recognized standards organizations.

2.5 Calibration

Equipment requiring calibration is calibrated periodically by the manufacturer or according to manufacturer's specifications. Additionally all equipment is verified for proper performance on a regular basis using in house standards or comparisons.

2.6 Measurement Uncertainty

The estimated combined standard uncertainty for radiated emissions and conducted emissions measurements are ± 3 dB.

Table 3: Emission Measurement Uncertainty

Parameter	Uncertainty
RF power, conducted	± 1.5 dB
Adjacent channel power	± 3 dB
Radiated emission of transmitter, valid up to 26 GHz	± 6 dB
Radiated emission of receiver, valid up to 26 GHz	± 6 dB
Temperature	± 2 °C
Humidity	± 10 %

3. General Product Information

3.1 Product Function and Intended Use

The EUT is a IEEE 802.11 b/g/n Network Controller Module With Integrated Bluetooth 4.0 (BLE). The Module has RF Shield and integrated Chip Antenna.
For details refer to the User Guide, Data Sheet and Circuit Diagram.

3.2 System Details and Ratings

Table 4: Basic Information of EUT

Item	EUT information
Kind of Equipment	IEEE 802.11 b/g/n Network Controller Module With Integrated Bluetooth 4.0 (BLE)
Type Designation	ATWINC3400-MR210CA
Brand Name	Microchip
FCC ID	2ADHKWINC3400
Canada ID	20266-ATWINC3400
Canada HVIN	ATWINC3400-MR210CA

Table 5: Technical Specification of EUT

Technical Specification	Value
Operating Frequencies	2412 MHz ~ 2462 MHz
Channel Spacing	20 MHz
Channel number	802.11b/g/n : 11 (2412 MHz ~ 2462 MHz)
Operation Voltage	3.0V to 4.2V (Typical = 3.3v)
Modulation	802.11b: DSSS ; 802.11g/n: OFDM
Antenna gain	0.5 dBi max@2.400 GHz

3.3 Independent Operation Modes

Basic operation modes are:

- A. Transmitting
 - 1. Low channel
 - 2. Middle channel
 - 3. High channel
- B. Receiving
- C. Standby
- D. Off

3.4 Noise Generating and Noise Suppressing Parts

Refer to the Circuit Diagram.

3.5 Submitted Documents

- Bill of Material
- PCB Layout
- Photo Document
- Technical Description
- Circuit Diagram
- Instruction Manual
- Rating Label

4. Test Set-up and Operation Modes

4.1 Principle of Configuration Selection

The equipment under test (EUT) was configured to measure its maximum power level. The test modes were adapted accordingly in reference to the instructions for use.

4.2 Test Operation and Test Software

Setup for testing: Test samples are provided with a I2C to USB interface which makes it possible to control them through a test software installed on a notebook computer.

This software was running on the laptop computer connected to the EUT. It was used to enable the operation modes listed in section 3.3 as appropriate.

The samples were used as follows:

Radiation: A000632215-002

Full test was applied on all test modes, but only worst case was shown

IEEE 802.11b mode:

Channel Low (2412MHz), Channel Mid (2437MHz) and Channel High (2462MHz) with 1Mbps data rate were chosen for full testing.

IEEE 802.11g mode:

Channel Low (2412MHz), Channel Mid (2437MHz) and Channel High (2462MHz) with 6Mbps data rate were chosen for full testing.

IEEE 802.11n HT 20 mode:

Channel Low (2412MHz), Channel Mid (2437MHz) and Channel High (2462MHz) with 6.5Mbps data rate were chosen for full testing.

4.3 Special Accessories and Auxiliary Equipment

The product has been tested together with the following additional accessories:

Description	Manufacturer	Model No.	Serial No.
Notebook(EMC-06)	Lenovo	TP00048A	PB-0F8B2

4.4 Countermeasures to achieve EMC Compliance

The test sample which has been tested contained the noise suppression parts as described in the Constructional Data Form or the Technical Construction File. No additional measures were employed to achieve compliance.

4.5 Test Setup Diagram

Diagram of Measurement Configuration for Radiation Test

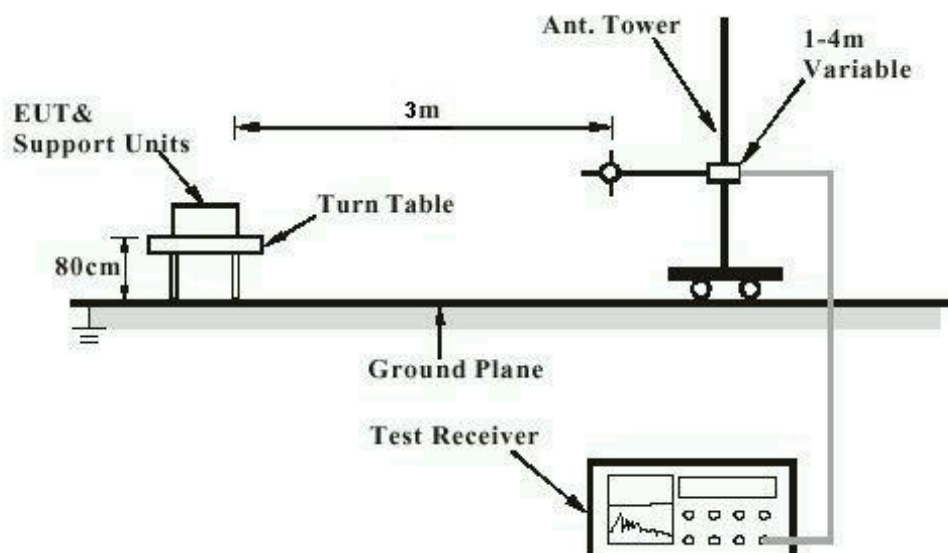

Note: Measurements above 1 GHz are done with a table height of 1.5m.

Diagram of Measurement Equipment Configuration for Mains Conduction Measurement (if applicable)

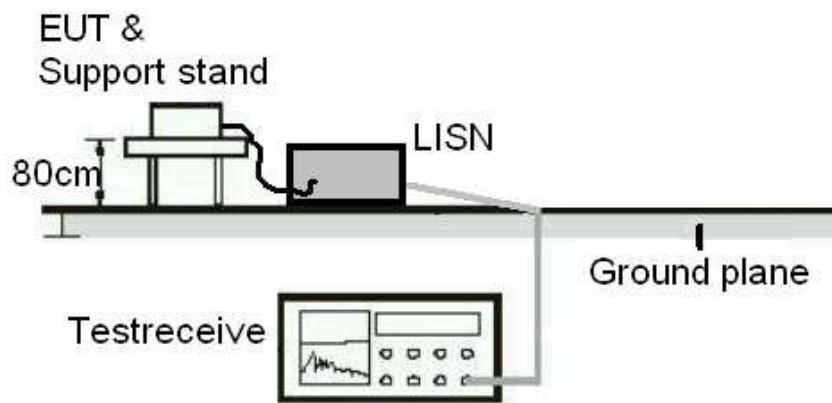
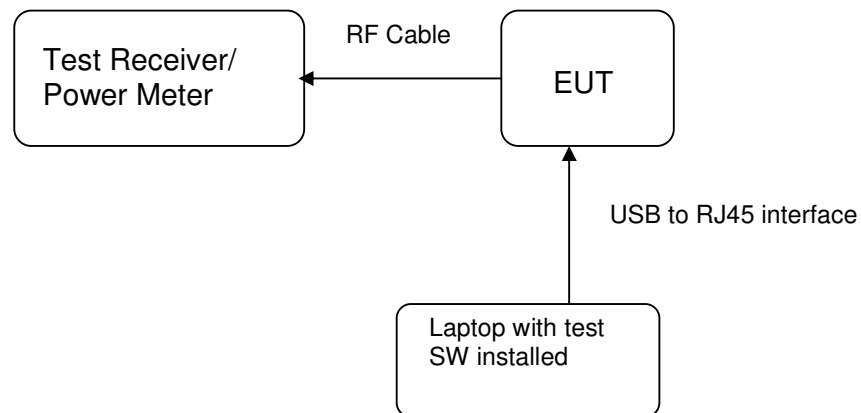

Diagram of Measurement Equipment Configuration for Conducted Transmitter Measurement



5. Test Results

5.1 Transmitter Requirement & Test Suites

5.1.1 Spurious Emission

RESULT: **Passed**

Test standard : FCC part 15.247(d), FCC 15.205, FCC 15.209, RSS-247 5.5 and RSS-Gen 8.9
LP0002(2016): 3.10.1, (5)

Basic standard : ANSI C63.10: 2009
Limits : Radiated emissions which fall in the restricted bands, as defined in FCC 15.205(a) and RSS-Gen i4, 8.9 (Table 6), must comply with the radiated emission limits specified in FCC 15.209(a) and RSS-Gen i4, 8.9 (Table 4 and 5).
Radiated emissions which fall in the restricted bands, as defined in LP0002(2016): 2.7 , must comply with the radiated emission limits specified in LP0002(2016): 2.8
Emission radiated outside the specified frequency bands must comply with the radiated emission limits specified in FCC 15.209(a), RSS-Gen i4, 8.9 (Table 4 and 5).
Emission radiated outside the specified frequency bands must comply with the radiated emission limits specified in LP0002(2016): 2.8

Kind of test site : 3m Semi-Anechoic Chamber

Test setup

Test Channel : Low/ Middle/ High
Operation mode : A, B

Remark: Testing was carried out within frequency range 30MHz to the tenth harmonic.

For details refer to Appendix D.

The Radiated Emissions testing was performed in the X, Y and Z axis orientation. The X Axis orientation is the worst-case and recorded in this test report. Due to the small size of the product and that there are no inductive components of significant size, 9kHz to 30MHz frequency range is not tested based on technical judgment.

6. Photographs of the Test Set-Up

Photograph 1: Set-up for Spurious Emissions (Front View)



Photograph 2: Set-up for Spurious Emissions (Back View 1)



Photograph 3: Set-up for Spurious Emissions (Back View 2)

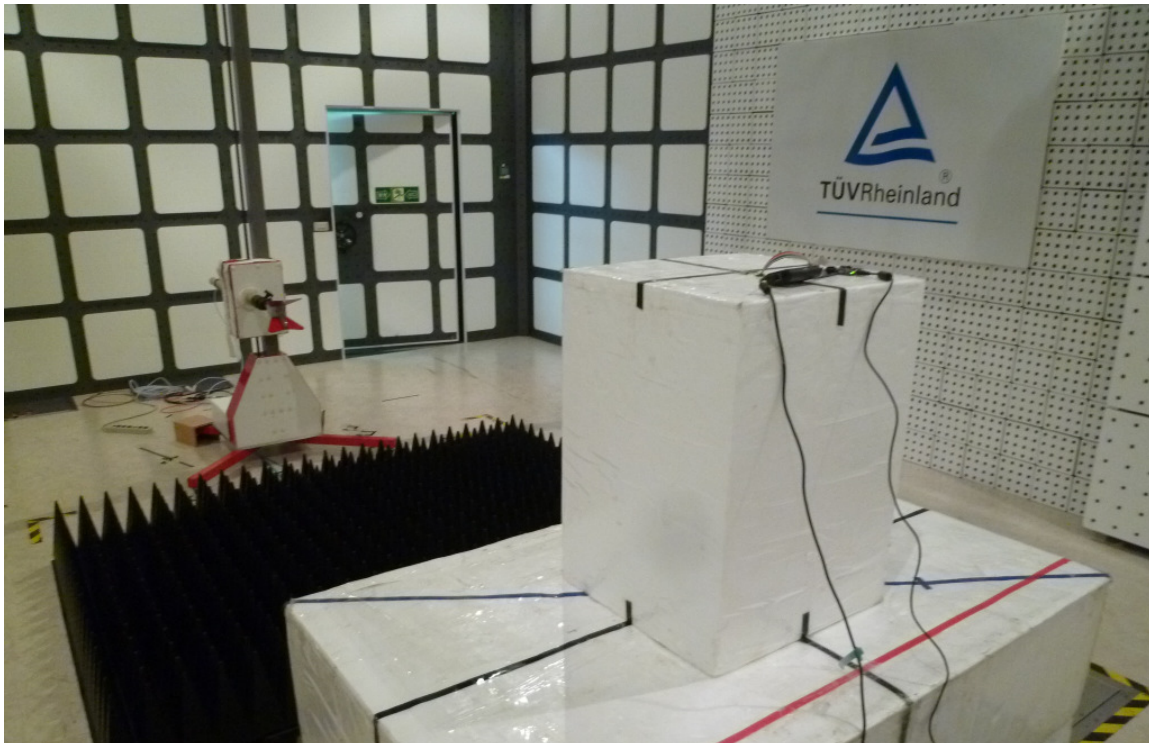

Photograph 4: Set-up for Spurious Emissions (Back View 3)



7. List of Tables

Table 1: Applied Standard and Test Levels	4
Table 2: List of Test and Measurement Equipment	6
Table 3: Emission Measurement Uncertainty.....	7
Table 4: Basic Information of EUT	8
Table 5: Technical Specification of EUT	8

8. List of Photographs

Photograph 1: Set-up for Spurious Emissions (Front View).....	14
Photograph 2: Set-up for Spurious Emissions (Back View 1)	15
Photograph 3: Set-up for Spurious Emissions (Back View 2)	16
Photograph 4: Set-up for Spurious Emissions (Back View 3).....	16