

Prüfbericht-Nr.: <i>Test Report No.:</i>	50141802 001	Auftrags-Nr.: <i>Order No.:</i>	114074446		Seite 1 von 57 <i>Page 1 of 57</i>
Kunden-Referenz-Nr.: <i>Client Reference No.:</i>	N/A	Auftragsdatum: <i>Order date:</i>	12-Feb-2018		
Auftraggeber: <i>Client:</i>	Microchip Technology Inc. 2355 West Chandler Blvd. Chandler, Arizona 85224-6199, United States.				
Prüfgegenstand: <i>Test item:</i>	IEEE 802.11 b/g/n Link Controller Module With Integrated Bluetooth				
Bezeichnung / Typ-Nr.: <i>Identification / Type No.:</i>	ATWILC3000-MR110UA				
Auftrags-Inhalt: <i>Order content:</i>	FCC Part 15C / IC RSS-247 Test report (BDR/EDR)				
Prüfgrundlage: <i>Test specification:</i>	FCC 47CFR Part 15: Subpart C Section 15.247 RSS-247 (02-2017)				
Wareneingangsdatum: <i>Date of receipt:</i>	14-Feb-2018				
Prüfmuster-Nr.: <i>Test sample No.:</i>	A000698723-002 A000698723-003				
Prüfzeitraum: <i>Testing period:</i>	08-Mar-2018 – 20-Apr-2018				
Ort der Prüfung: <i>Place of testing:</i>	EMC/RF Laboratory Taipei				
Prüflaboratorium: <i>Testing laboratory:</i>	TUV Rheinland Taiwan Ltd.				
Prüfergebnis*: <i>Test result*:</i>	Pass				
geprüft von / tested by:			kontrolliert von / reviewed by:		
06-Jun-2018 Jack Chang/Project Manager			06-Jun-2018 Arvin Ho/Vice General Manager		
Datum <i>Date</i>	Name / Stellung <i>Name / Position</i>	Unterschrift <i>Signature</i>	Datum <i>Date</i>	Name / Stellung <i>Name / Position</i>	Unterschrift <i>Signature</i>
Sonstiges / Other:					
Zustand des Prüfgegenstandes bei Anlieferung: <i>Condition of the test item at delivery:</i>			Prüfmuster vollständig und unbeschädigt <i>Test item complete and undamaged</i>		
* Legende: 1 = sehr gut 2 = gut 3 = befriedigend 4 = ausreichend 5 = mangelhaft P(ass) = entspricht o.g. Prüfgrundlage(n) F(ail) = entspricht nicht o.g. Prüfgrundlage(n) N/A = nicht anwendbar N/T = nicht getestet Legend: 1 = very good 2 = good 3 = satisfactory 4 = sufficient 5 = poor P(ass) = passed a.m. test specification(s) F(ail) = failed a.m. test specification(s) N/A = not applicable N/T = not tested					
Dieser Prüfbericht bezieht sich nur auf das o.g. Prüfmuster und darf ohne Genehmigung der Prüfstelle nicht auszugsweise vervielfältigt werden. Dieser Bericht berechtigt nicht zur Verwendung eines Prüfzeichens. <i>This test report only relates to the a. m. test sample. Without permission of the test center this test report is not permitted to be duplicated in extracts. This test report does not entitle to carry any test mark.</i>					

TEST SUMMARY

5.1.1 ANTENNA REQUIREMENT

RESULT: *Passed*

5.1.2 PEAK OUTPUT POWER

RESULT: *Passed*

5.1.3 20DB BANDWIDTH

RESULT: *Passed*

5.1.4 99% BANDWIDTH

RESULT: *Passed*

5.1.5 CONDUCTED SPURIOUS EMISSIONS AND FREQUENCY BAND EDGE MEASURED IN 100KHz BANDWIDTH

RESULT: *Passed*

5.1.6 SPURIOUS EMISSION

RESULT: *Passed*

5.1.7 FREQUENCY SEPARATION

RESULT: *Passed*

5.1.8 NUMBER OF HOPPING FREQUENCY

RESULT: *Passed*

5.1.9 TIME OF OCCUPANCY

RESULT: *Passed*

5.2.1 MAINS CONDUCTED EMISSIONS

RESULT: *Passed*

6.1.1 ELECTROMAGNETIC FIELDS

RESULT: *Passed*

Contents

1.	GENERAL REMARKS	5
1.1	COMPLEMENTARY MATERIALS.....	5
2.	TEST SITES	6
2.1	TEST FACILITY.....	6
2.2	LIST OF TEST AND MEASUREMENT INSTRUMENTS.....	7
2.3	TRACEABILITY	8
2.4	CALIBRATION	8
2.5	MEASUREMENT UNCERTAINTY	8
3.	GENERAL PRODUCT INFORMATION.....	9
3.1	PRODUCT FUNCTION AND INTENDED USE	9
3.2	SYSTEM DETAILS AND RATINGS.....	9
3.3	INDEPENDENT OPERATION MODES.....	11
3.4	NOISE GENERATING AND NOISE SUPPRESSING PARTS	12
3.5	SUBMITTED DOCUMENTS.....	12
4.	TEST SET-UP AND OPERATION MODES.....	13
4.1	PRINCIPLE OF CONFIGURATION SELECTION	13
4.2	TEST OPERATION AND TEST SOFTWARE.....	13
4.3	SPECIAL ACCESSORIES AND AUXILIARY EQUIPMENT	13
4.4	COUNTERMEASURES TO ACHIEVE EMC COMPLIANCE.....	14
4.5	TEST SETUP DIAGRAM	14
5.	TEST RESULTS	16
5.1	TRANSMITTER REQUIREMENT & TEST SUITES	16
5.1.1	<i>Antenna Requirement</i>	<i>16</i>
5.1.2	<i>Peak Output Power.....</i>	<i>17</i>
5.1.3	<i>20dB Bandwidth</i>	<i>18</i>
5.1.4	<i>99% Bandwidth</i>	<i>22</i>
5.1.5	<i>Conducted spurious emissions and Frequency Band Edge measured in 100kHz Bandwidth.....</i>	<i>26</i>
5.1.6	<i>Spurious Emission</i>	<i>34</i>
5.1.7	<i>Frequency Separation.....</i>	<i>35</i>
5.1.8	<i>Number of hopping frequency.....</i>	<i>37</i>
5.1.9	<i>Time of Occupancy</i>	<i>40</i>
5.2	MAINS EMISSIONS.....	43
5.2.1	<i>Mains Conducted Emissions.....</i>	<i>43</i>
6.	SAFETY HUMAN EXPOSURE	44

6.1	RADIO FREQUENCY EXPOSURE COMPLIANCE	44
6.1.1	<i>Electromagnetic Fields.....</i>	<i>44</i>
7.	PHOTOGRAPHS OF THE TEST SET-UP.....	45
8.	LIST OF TABLES	57
9.	LIST OF PHOTOGRAPHS.....	57

1. General Remarks

1.1 Complementary Materials

The following attachments are integral parts of this test report:

- Appendix P: Photo Documentation**
(File Name: 50141802 APPENDIXP)
- Appendix D: Test Result of Radiated Emissions**
(File Name: 50141802 APPENDIXD)

Test Specifications

The following standards were applied

Table 1: Applied Standard and Test Levels

Radio
FCC 47CFR Part 15: Subpart C Section 15.247
FCC 47CFR Part 2: Subpart J Section 2.1091
RSS-247 Issue 2 (Feb 2017)
RSS-102 Issue 5
RSS-Gen, Issue 5, April 2018
ANSI C63.10:2013
KDB558074 D01 DTS Meas Guidance v03r05
KDB447498 D01 General RF Exposure Guidance v06

2. Test Sites

2.1 Test Facility

TUV Rheinland Taiwan Ltd.
Taipei Office

11F. No.758, Sec. 4, Bade Rd., Songshan Dist.
Taipei City 105
Taiwan (R.O.C.)

FCC RegistrationNo.: 340738
IC Canada Registration No.: 9465A-1
TAF Accredited NCC Test Lab. No.:0759
TAF ISO17025 Certification effective periods: 2016-Jul-1st to 2019-Jun-30th



Testing Laboratory
0759

2.2 List of Test and Measurement Instruments

Table 2: List of Test and Measurement Equipment

Kind of Equipment	Manu-facturer	Type	S/N	Last Calibration	Next Calibration
Test Software	Farad	EZ_EM C	Ver. TUV3A1	N/A	N/A
EMI Test Receiver	R&S	ESCI 7	101549	2017/11/10	2018/11/10
Spectrum Analyzer	R&S	FSV 40	100921	2017/05/02	2018/05/01
Spectrum Analyzer	Agilent	N9010A	MY53470241	2017/05/23	2018/05/22
Preamplifier (30MHz -1GHz)	HP	8447F	2805A03335	2017/08/14	2018/08/14
Preamplifier (18 GHz -40 GHz)	COM-POWER	PAM-840	461257	2018/01/18	2019/01/18
Pre-Amplifier (1GHz~18GHz)	EM Electronics	EM01G18G	60558	2017/11/21	2018/11/21
Bilog Antenna	TESEQ	CBL6111D	29804	2017/08/18	2018/08/18
Horn Antenna	ETS-Lindgren	3117	201918	2017/08/18	2018/08/18
Horn Antenna (18GHz~40GHz)	COM-POWER	AH-840	101031	2017/11/28	2018/11/28
Temp. & Humid. Chamber	Giant Force	GCT-099-40-S	MAF0103-007	2017/03/09	2019/03/09
Loop Antenna	Schwarzbeck	FMZB 1513	1513-076	2017/06/14	2018/06/14
LISN (1 phase)	R&S	ENV216	101243	2017/06/18	2018/06/18
LISN	R&S	ENV216	101262	2017/06/22	2018/06/21
Test Software	Audix	e3	Ver. 9	N/A	N/A
Test Software	Agilent	300328 testsystem	V1.9.1	N/A	N/A
Power sensor	Agilent	U2021XA	MY54020001	2017/03/08	2018/05/30

2.3 Traceability

All measurement equipment calibrations are traceable to NML(Taiwan)/NIST(USA) or where calibration is performed outside Taiwan, to equivalent nationally recognized standards organizations.

2.4 Calibration

requiring calibration is calibrated periodically in a suitably accredited Calibration Lab. Additionally all equipment is verified for proper performance on a regular basis using in house standards or comparisons.

2.5 Measurement Uncertainty

The estimated combined standard uncertainty for radiated emissions and conducted emissions measurements:

Table 3: Emission Measurement Uncertainty

Parameter	Uncertainty
RF power, conducted	± 1.5 dB
Adjacent channel power	± 3 dB
Radiated emission of transmitter, valid up to 26 GHz	± 6 dB
Radiated emission of receiver, valid up to 26 GHz	± 6 dB
Temperature	± 2 °C
Humidity	± 10 %

3. General Product Information

3.1 Product Function and Intended Use

The EUT is an IEEE 802.11 b/g/n Link Controller Module With Integrated Bluetooth. The Module has RF Shield and u.FL connector for External Antenna(s).

For details refer to the User Guide, Data Sheet and Circuit Diagram.

3.2 System Details and Ratings

Table 4: Basic Information of EUT

Item	EUT information
Kind of Equipment/Test Item	IEEE 802.11 b/g/n Link Controller Module With Integrated Bluetooth
Type Identification	ATWILC3000-MR110UA
FCC ID	2ADHKWILC3000U
IC ID	20266-WILC3000UA
HVIN	ATWILC3000-MR110UA

Table 5: Technical Specification of EUT

Technical Specification	Value
Operating Frequency	2402 MHz ~ 2480 MHz
Channel Spacing	1 MHz
Channel number	79
Operation Voltage	2.5V to 4.2V (Typical = 3.3V)
Modulation	GFSK, $\pi/4$ DQPSK, 8DPSK
Antenna gain	Refer external antenna list

Table 6: External Antenna list
Antennas no. 4,6 and 9 selected for testing as worst case antennas

S/no.	P/N	Vendor	Antenna Gain @ 2.4GHz Band	Antenna type	Remarks
1	W3525B039	Pulse Electronics Corporation	2 dBi	PCB	Cable length 100mm
2	RN-SMA-4	Microchip	2.2 dBi	Dipole	
3	RFDP A870920IMLB301	WALSIN	1.84 dBi	Dipole-DB	Dual Band
4	RFMTA331215IMAB701	WALSIN	3.8 dBi	Metal Stamp	Cable length 150mm
5	RFMTA331240IMAB701	WALSIN	3.0 dBi	Metal Stamp	Antenna same as S/No.4, cable length 400 mm
6	RFPCA381013IMAB701	WALSIN	4.50 dBi	PCB	Cable length 130mm
7	RFPCA381035IMAB701	WALSIN	2.7 dBi	PCB	Antenna same as S/No.6, cable length 350mm
8	RFA-02-3-C5H1	Aristotle	3 dBi	Dipole	
9	RFA-02-5-C7H1	Aristotle	5 dBi	Dipole-Long	
10	RFA-02-P33	Aristotle	2 dBi	PCB	Cable length 150mm
11	1461530100	Molex	3 dBi	PCB/Flexi	Cable length 100mm Dual Band
12	RN-SMA-S	Microchip	0.56 dBi	Dipole-short	
13	RN-SMA-7	Microchip	5 dBi	Dipole-Long	
14	RFA-02-5-F7H1	Aristotle	5 dBi	Dipole-Long	
15	RFA-02-D3	Aristotle	2 dBi	Dipole-no encl.	
16	RFA-02-G03	Aristotle	2 dBi	Metal Stamp	Cable length 150mm
17	RFA-02-L2H1	Aristotle	2 dBi	Dipole	
18	RFA-02-P05	Aristotle	2 dBi	PCB	Cable length 150mm
19	RFA-02-C2M2	Aristotle	2 dBi	Dipole	

Table 7: Frequency hopping information

Technical Specification	Description
Hopping Range	Hereby we declare that the maximum frequency of this device is: 2402-2480MHz. This is according the Bluetooth Core Specification V2.1+EDR for devices which will be operated in the USA.
Hopping Sequence	Example of a 79 hopping sequence in data mode: 33,04,21,44,23,42,53,46,55,48,40,59,72,29,76,31,08,73, 07,75,09,45,60,39,58,13,47,11,77,52,35,50,65,54,67,56, 69,62,71,64, 7,25,27,66,57,70,74,61,78,63,10,41,05,43, 15,44,64,68,02,70,06,01,51,03,55,05,03,66,53,49,36,47,
Receiver input bandwidth	<p>The input bandwidth of the receiver is 1MHz. In every connection one Bluetooth device is the master and the other one is the slave. The master determines the hopping sequence. The slave follows this sequence. Both devices shift between RX and TX time slot according to the clock of the master.</p> <p>Additionally the type of connection is set up at the beginning of the connection. The master adapts its hopping frequency and its TX/RX timing according to the packet type of the connection. Also the slave of the connection will use these settings.</p> <p>Repeating of a packer has no influence on the hopping sequence. The hopping sequence generated by the master of the connection will be followed in any case.</p> <p>That means a repeated packet will not be send on the same frequency, it is send on the next frequency of the hopping sequence.</p>

3.3 Independent Operation Modes

The basic operation modes are:

- A. Transmitting
 - 1. Low channel
 - 2. Middle channel
 - 3. High channel
- B. Receiving
 - 1. Low channel
 - 2. Middle channel
 - 3. High channel

3.4 Noise Generating and Noise Suppressing Parts

Refer to the Circuit Diagram.

3.5 Submitted Documents

- Circuit Diagram
- Instruction Manual
- Rating Label
- Technical Description

4. Test Set-up and Operation Modes

4.1 Principle of Configuration Selection

The equipment under test (EUT) was configured to measure its maximum power level. The test modes were adapted accordingly in reference to the instructions for use.

4.2 Test Operation and Test Software

Setup for testing: Test samples are provided with an I2C to USB Adaptor and UART Interface which makes it possible to control them through the test software installed on a notebook computer.

This software was running on the laptop computer connected to the EUT. It was used to enable the operation modes listed in section 3.3 as appropriate.

The samples were used as follows:

Conducted: A000698723-002

Radiation: A000698723-003

Full test was applied on all test modes, but only worst case was shown.

Bluetooth test mode:

Channel Low (2402MHz), Channel Mid (2441MHz) and Channel High (2480MHz) were chosen for full testing.

4.3 Special Accessories and Auxiliary Equipment

The product has been tested together with the following additional accessories:

Description	Manufacturer	Model No.	Serial No.
Notebook(EMC-06)	Lenovo	TP00048A	PB-0F8B2
Test tool	Microchip	WILC3000/WINC3400 rev7189	N/A

4.4 Countermeasures to achieve EMC Compliance

The test sample which has been tested containing the noise suppression parts as in the Photo Appendix and the Test Setup Photos. No additional measures were employed to achieve compliance.

4.5 Test Setup Diagram

Diagram of Measurement Configuration for Radiation Test

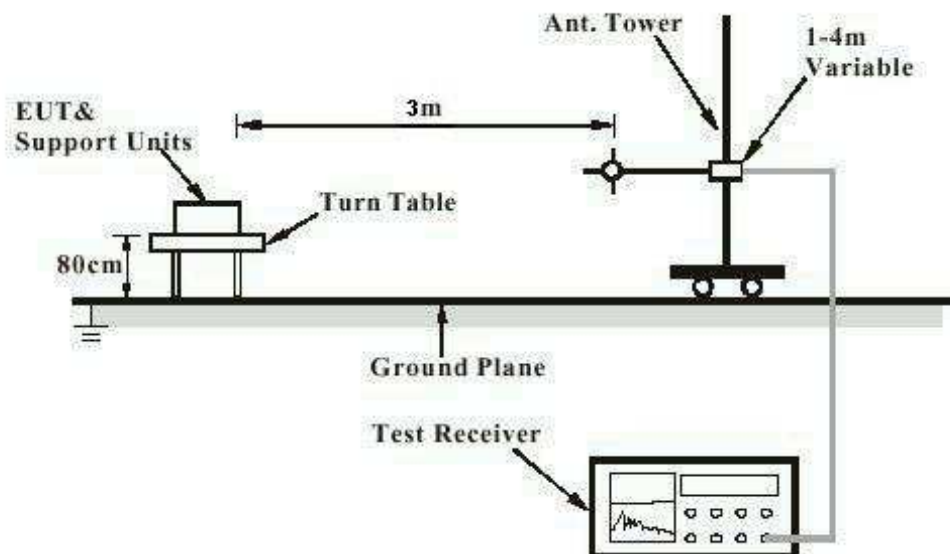

Note: Measurements above 1 GHz are done with a table height of 1.5m

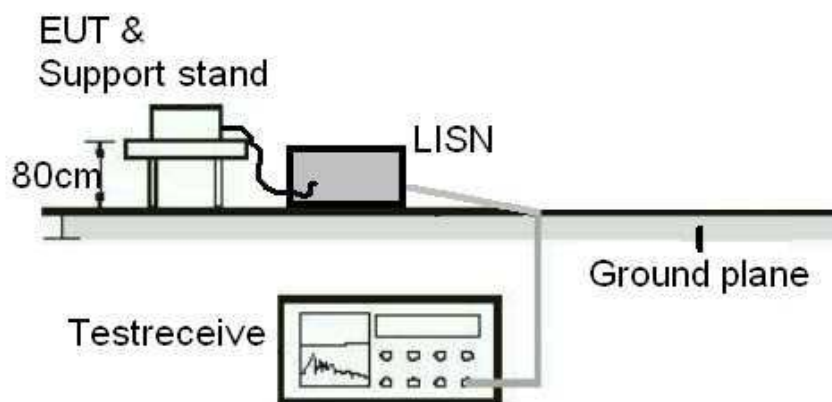
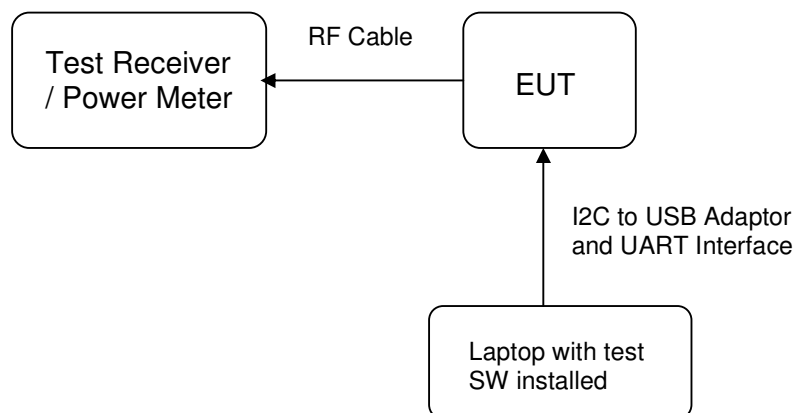
Diagram of Measurement Equipment Configuration for Mains Conduction Measurement

Diagram of Measurement Equipment Configuration for Conducted Transmitter Measurement

5. Test Results

5.1 Transmitter Requirement & Test Suites

5.1.1 Antenna Requirement

RESULT: **Passed**

Test standard	:	LP0002(2016): 2.2, 3.10.1.3 FCC Part 15.247(b)(4), Part 15.203 and RSS- Gen 8.3
Requirement	:	use of approved antennas only with directional gains that do not exceed 6 dBi

According to the manufacturer declaration, the EUT has an antenna with Max directional gain of 5dBi (refer External Antenna List). The antenna is connected through a proprietary connector with no possibility of replacement with a non-approved antenna by the end-user. Therefore, the EUT is considered to comply with this provision.

Refer to EUT photo for details.

5.1.2 Peak Output Power

RESULT:
Passed

Test standard : FCC Part 15.247(b)(1),
 RSS-247 5.4(2)
 LP0002(2016): 3.10.1.2
 Basic standard : ANSI C63.10:2013
 LP0002(2016) Appendix II
 Kind of test site : Shielded room

Test setup

Test Channel : Low/ Middle/ High
 Operation Mode : A

Ambient temperature : 22-26 °C
 Relative humidity : 50-65 %
 Atmospheric pressure : 100-103 kPa

Table 8: Test result of Peak Output Power, GFSK modulation

Channel	Channel Frequency	Peak Output Power		Limit	Power Setting
	(MHz)	(dBm)	(W)	(W)	PPA, PA, DG
Low Channel	2402	9.37	0.00865	0.125	6, 12, -8
Middle Channel	2441	9.43	0.00877	0.125	6, 12, -8
High Channel	2480	9.41	0.00873	0.125	6, 12, -8

Table 9: Test result of Peak Output Power, 8DPSK modulation

Channel	Channel Frequency	Peak Output Power		Limit	Power Setting
	(MHz)	(dBm)	(W)	(W)	PPA, PA, DG
Low Channel	2402	9.36	0.00863	0.125	6, 12, -8
Middle Channel	2441	9.40	0.00871	0.125	6, 12, -8
High Channel	2480	9.38	0.00867	0.125	6, 12, -8

Pmax: 8.77mW

5.1.3 20dB Bandwidth

RESULT:
Passed

Test standard : FCC Part 15.247(a)(1),
 RSS-247 5.1(1)
 LP0002(2016): 3.10.1.6 (1) (A)

Basic standard : ANSI C63.10:2013
 LP0002(2016) Appendix II

Test setup

Test Channel : Low/ Middle/ High
 Operation Mode : A

Ambient temperature : 22-26°C
 Relative humidity : 50-65%
 Atmospheric pressure : 100-103 kPa

Table 10: Test result of 20dB Bandwidth, GFSK modulation

Channel	Channel Frequency (MHz)	20dB Bandwidth (MHz)	Limit (MHz)	Result
Low Channel	2402	0.959	1.5	Pass
Mid Channel	2441	0.959	1.5	Pass
High Channel	2480	0.957	1.5	Pass

Note: Limit is for Channel Separation of 1 MHz and a power limit of 125 mW.

Table 11: Test result of 20dB Bandwidth, 8DPSK modulation

Channel	Channel Frequency (MHz)	20dB Bandwidth (kHz)	Limit (MHz)	Result
Low Channel	2402	1.238	1.5	Pass
Mid Channel	2441	1.248	1.5	Pass
High Channel	2480	1.262	1.5	Pass

Note: Limit is for Channel Separation of 1 MHz and a power limit of 125 mW.

If the carrier separation frequency of a Bluetooth Device is set at 1 MHz due to the firmware setting and the Bluetooth Standard, then for power <125 mW the limit for the 20 dB Bandwidth, becomes 1 MHz / 0.66666 = 1.5 MHz.

Test Plot of 20dB Bandwidth, GFSK modulation

Low Channel

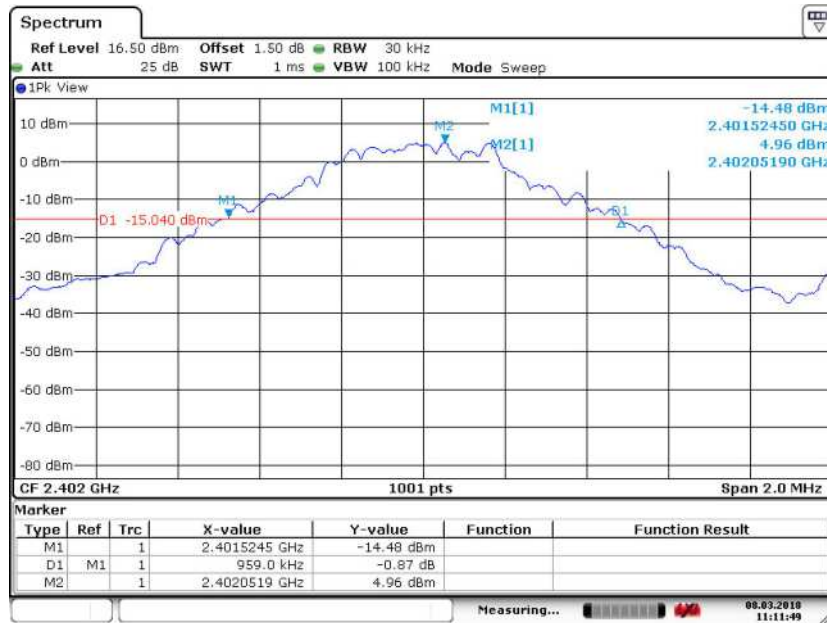

Date: 8.MAR.2018 11:11:49

Middle Channel

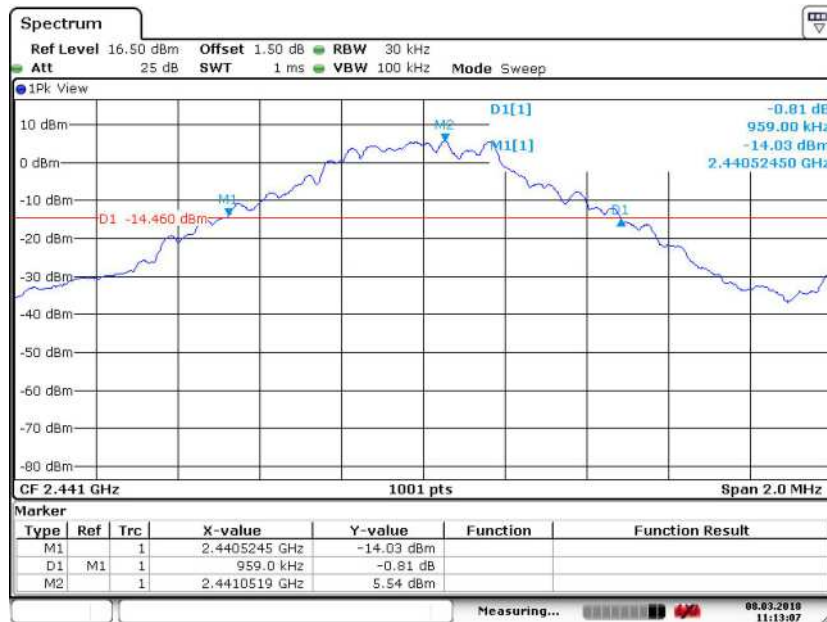

Date: 8.MAR.2018 11:13:07

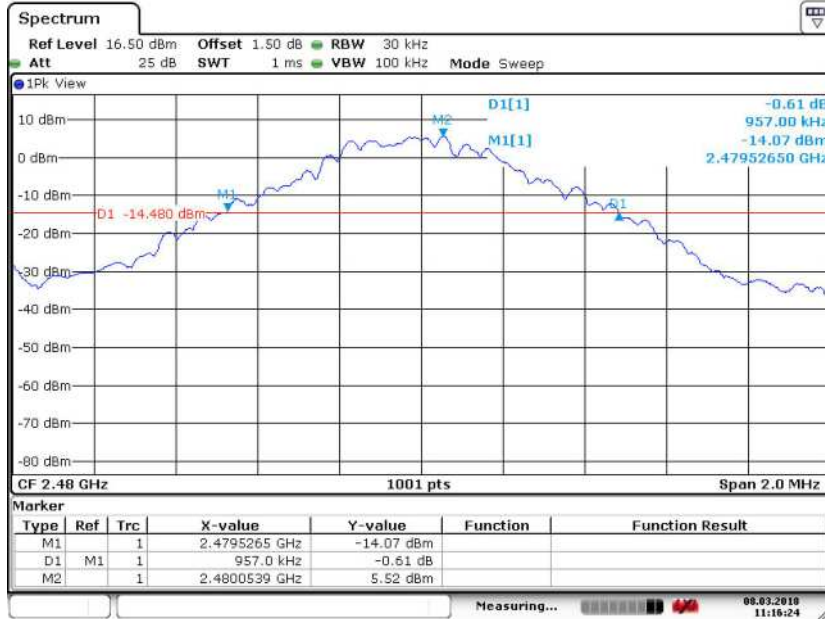
High Channel

Date: 8.MAR.2018 11:16:24

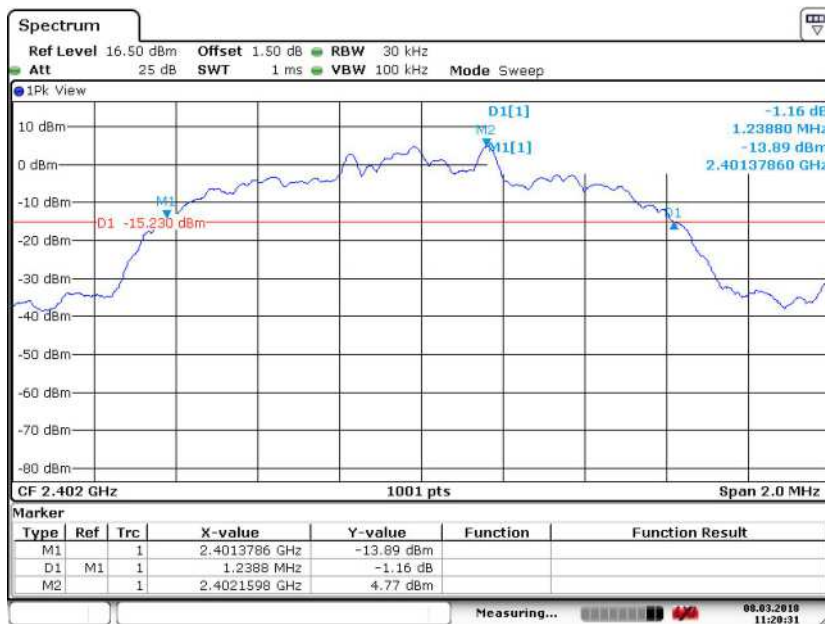
Test Plot of 20dB Bandwidth, 8DPSK modulation
Low Channel

Date: 8.MAR.2018 11:20:31

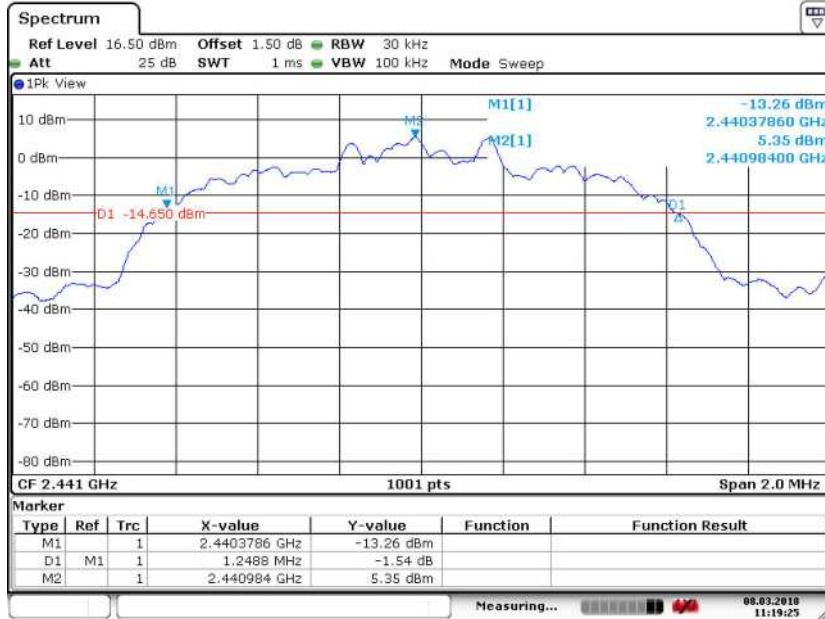
Middle Channel

Date: 8.MAR.2018 11:19:25

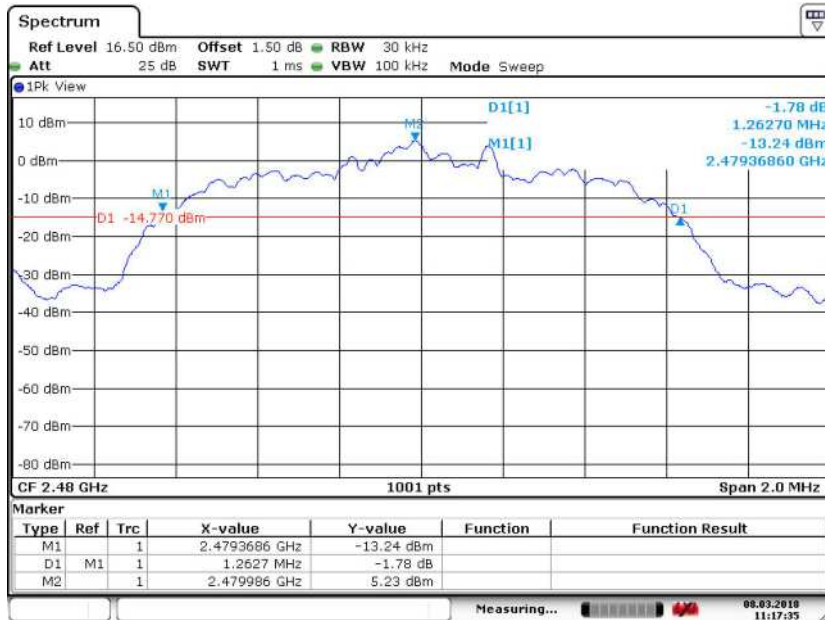
High Channel

Date: 8.MAR.2018 11:17:36

5.1.4 99% Bandwidth**RESULT:****Passed**

Test standard : RSS-Gen (Issue 5)
Basic standard : RSS-Gen (Issue 5)
Kind of test site : Shielded room/Conducted room

Test setup

Test Channel : Low/ Middle/ High
Operation Mode : A

Ambient temperature : 22-26°C
Relative humidity : 50-65%

Table 12: Test result of 99% Bandwidth, GFSK modulation

Channel	Channel Frequency (MHz)	99% Bandwidth (MHz)
Low Channel	2402	0.88111
Middle Channel	2441	0.88412
High Channel	2480	0.88412

Table 13: Test result of 99% Bandwidth, PSK modulation

Channel	Channel Frequency (MHz)	99% Bandwidth (MHz)
Low Channel	2402	1.1508
Middle Channel	2441	1.1479
High Channel	2480	1.1449

Test Plot of 99% Bandwidth, GFSK modulation

Low Channel

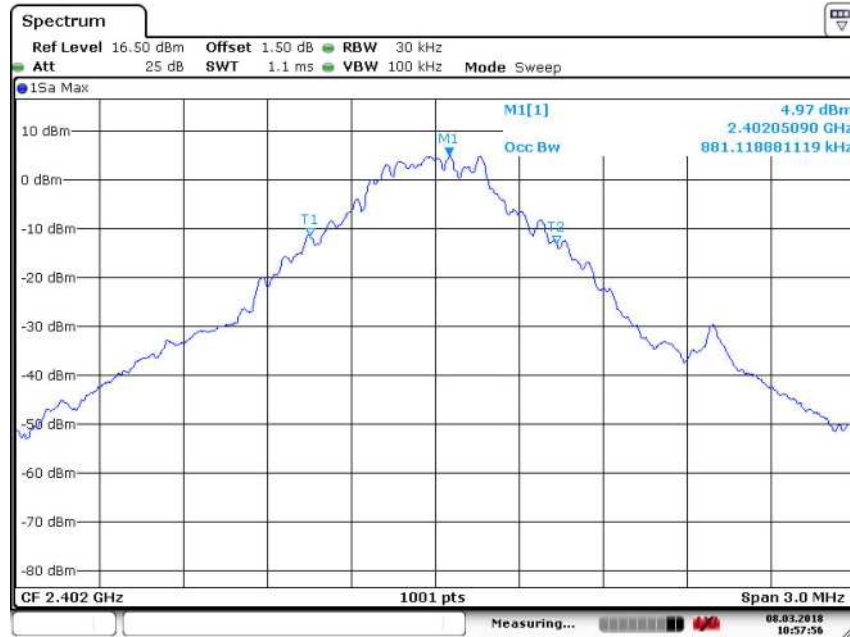

Date: 8.MAR.2018 10:57:56

Middle Channel

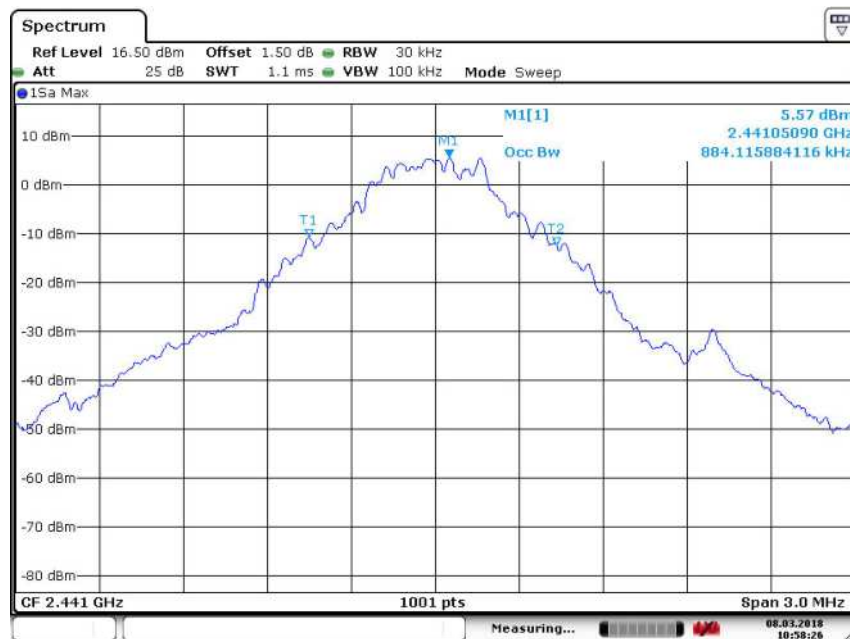

Date: 8.MAR.2018 10:58:26

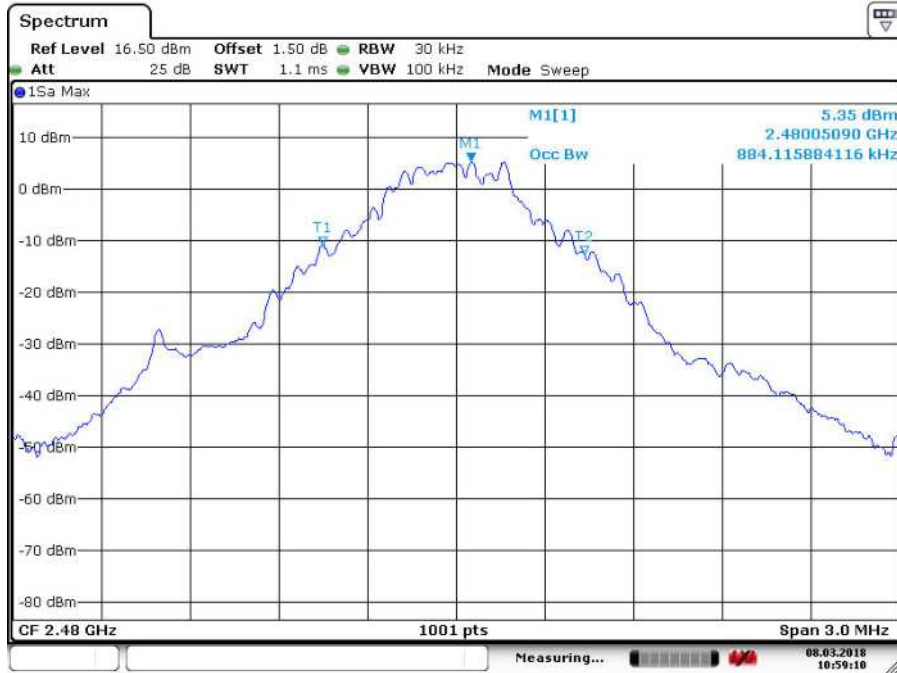
High Channel

Date: 8.MAR.2018 10:59:10

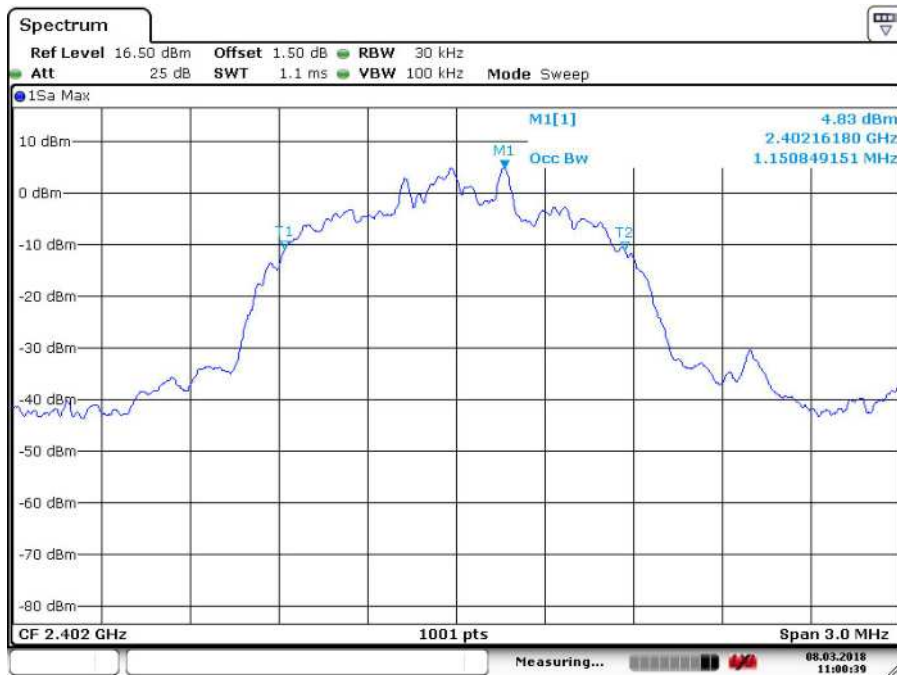
Test Plot of 99% Bandwidth, 8DPSK modulation
Low Channel

Date: 8.MAR.2018 11:00:40

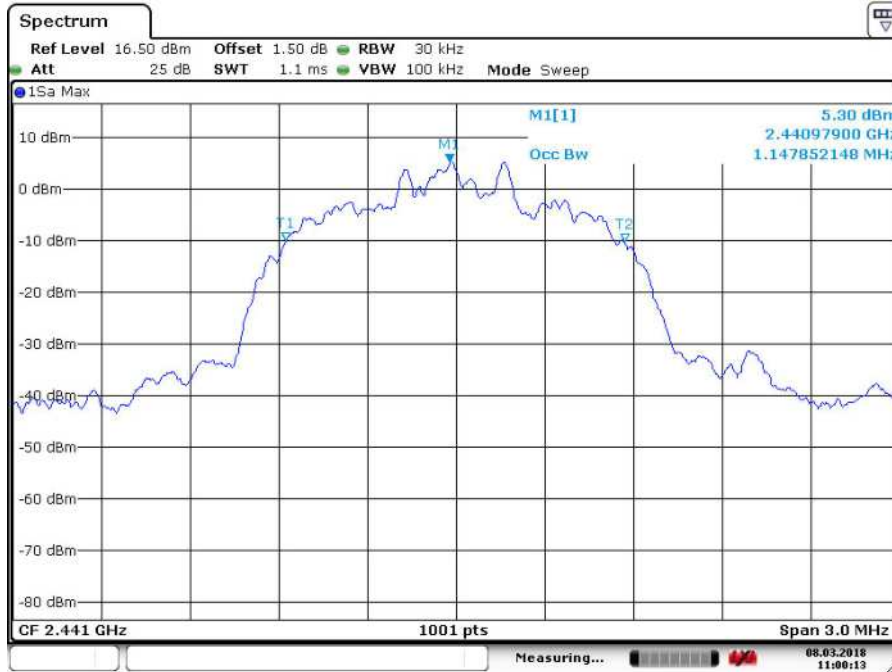
Middle Channel

Date: 8.MAR.2018 11:00:13

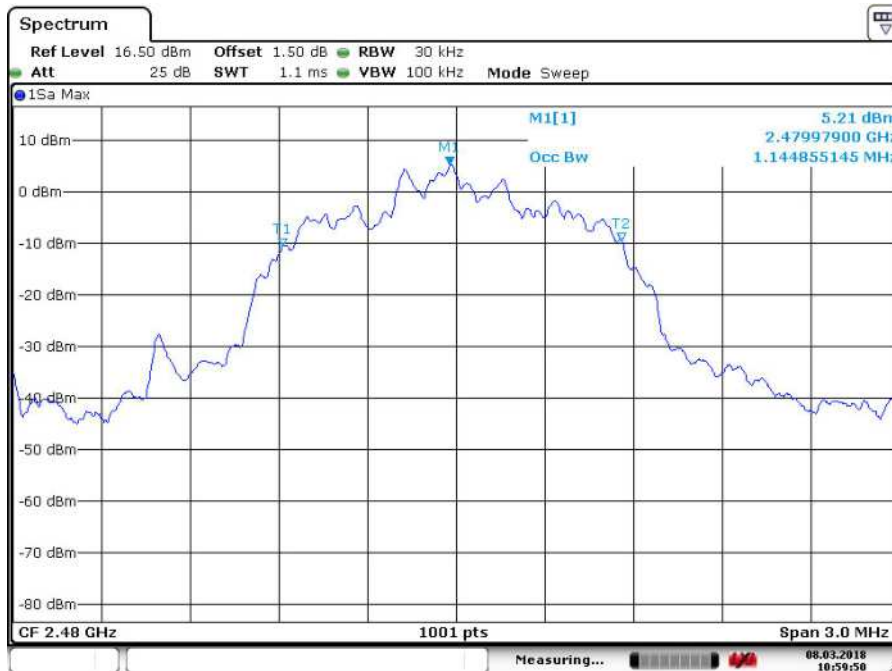
High Channel

Date: 8.MAR.2018 10:59:50

5.1.5 Conducted spurious emissions and Frequency Band Edge measured in 100kHz Bandwidth

RESULT:**Passed**

Test standard	:	FCC part 15.247(d), RSS-247 5.5 LP0002(2016): 3.10.1.5
Basic standard	:	ANSI C63.10:2013 LP0002(2016) Appendix II
Limit	:	20dB (below that in the 100kHz bandwidth within the band that contains the highest level of the desired power)
Kind of test site	:	Shielded room

Test setup

Test Channel	:	Low/ Mid/ High for spurious, Low/ High for Band Edge
Operation Mode	:	A
Ambient temperature	:	22-26°C
Relative humidity	:	50-65%
Atmospheric pressure	:	100-103 kPa

All emissions are more than 20dB below fundamental, details refer to following test plot, and compliance is achieved as well.

Due to the small size of the product and that there are no inductive components of significant size, 9kHz to 30MHz frequency range is not tested based on technical judgment.

Test Plot of 100kHz Conducted Emissions, GFSK modulation

Low Channel

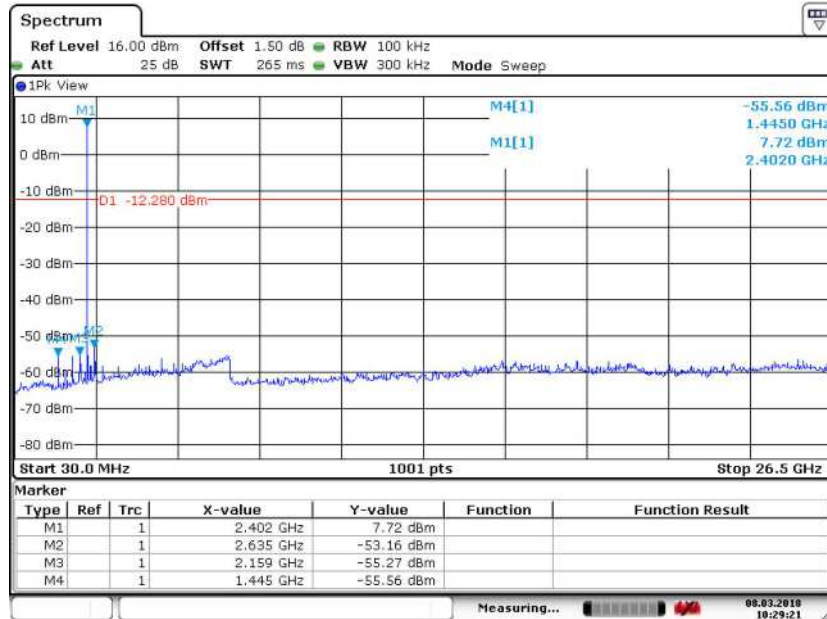

Date: 8.MAR.2018 10:29:21

Middle Channel

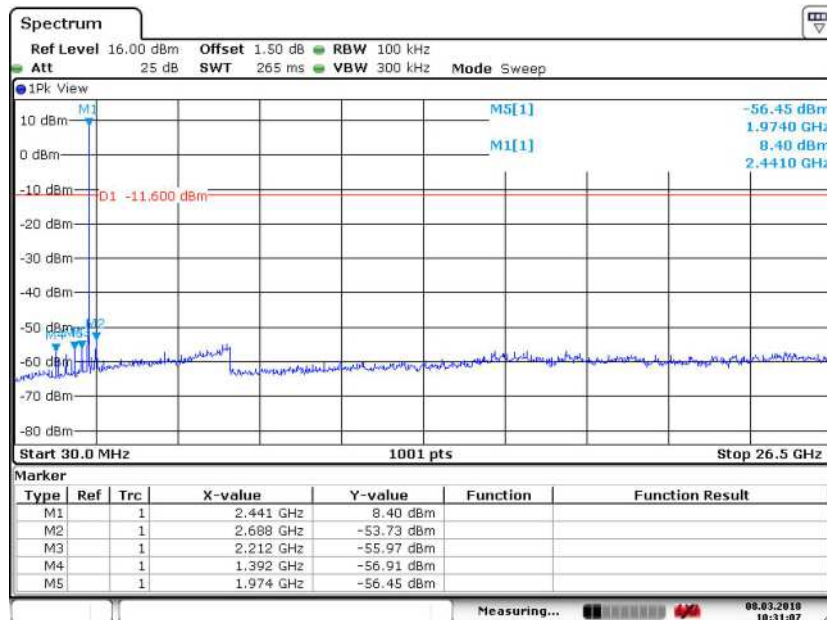

Date: 8.MAR.2018 10:31:07

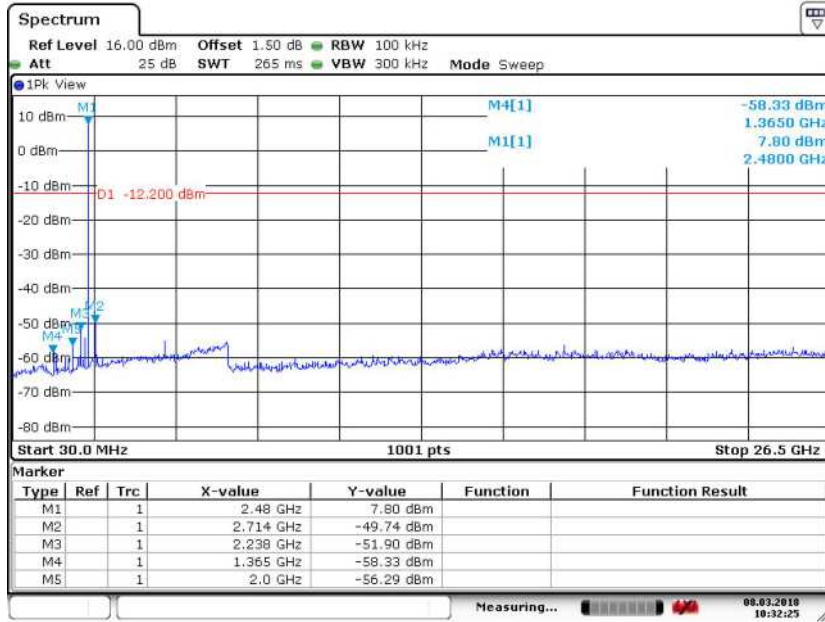
High Channel

Date: 8 MAR 2018 10:32:25

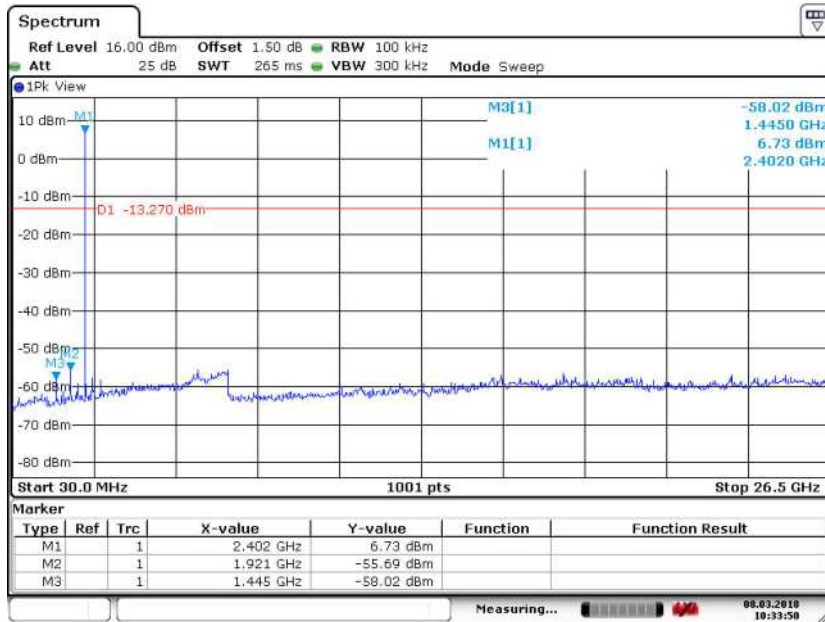
Test Plot of 100kHz Conducted Emissions, 8DPSK modulation
Low Channel

Date: 8 MAR 2018 10:33:51

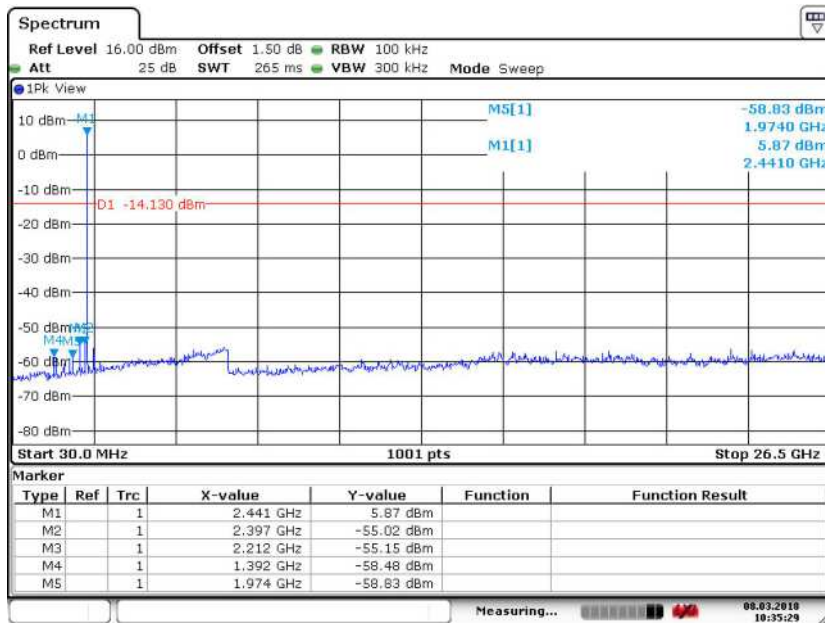
Middle Channel

Date: 8.MAR.2018 10:35:28

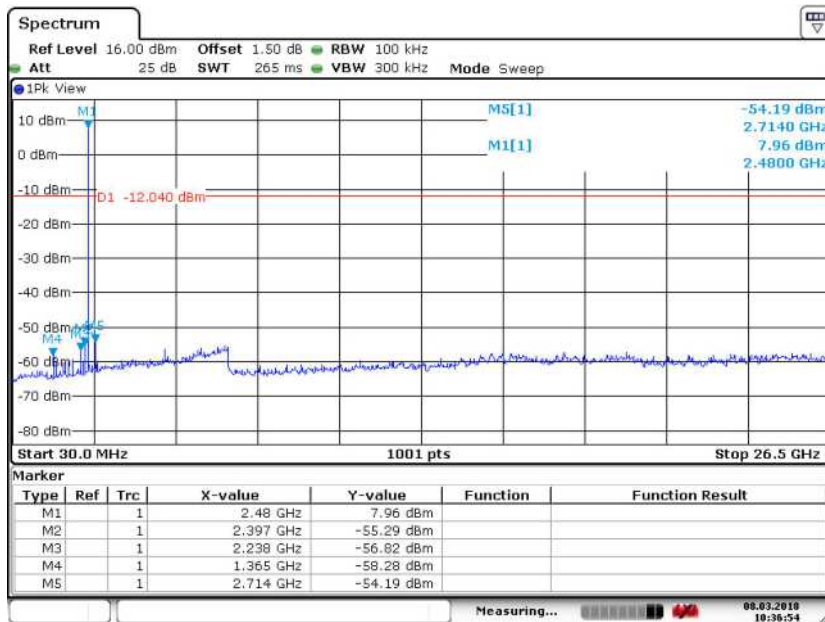
High Channel

Date: 8.MAR.2018 10:36:54

Test Plot of 100kHz Bandwidth of Frequency Band Edge, GFSK modulation

Low Channel

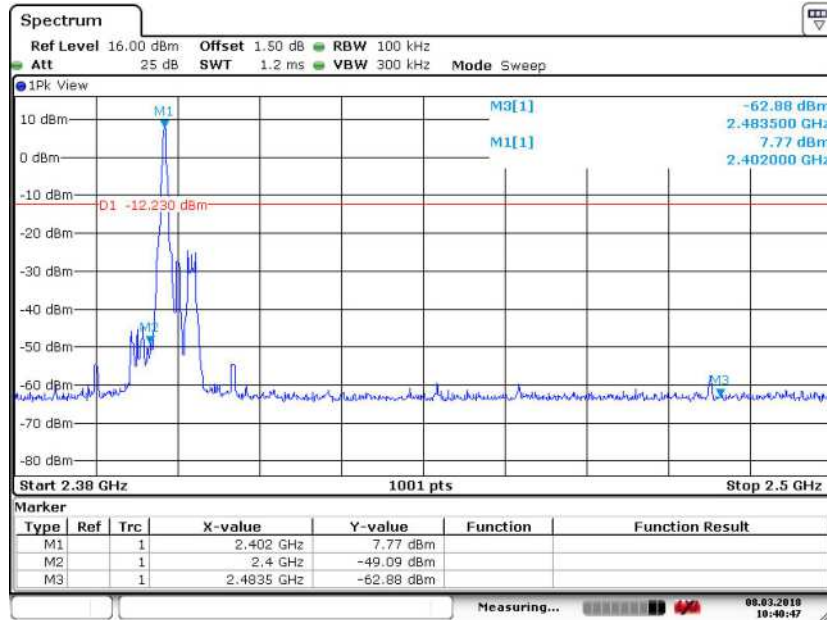

Date: 8.MAR.2018 10:40:47

High Channel

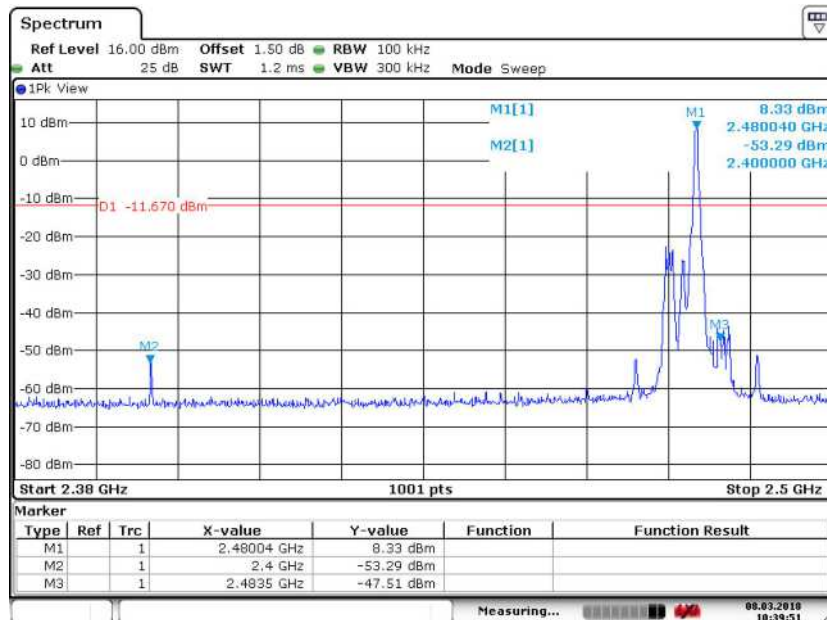

Date: 8.MAR.2018 10:39:51

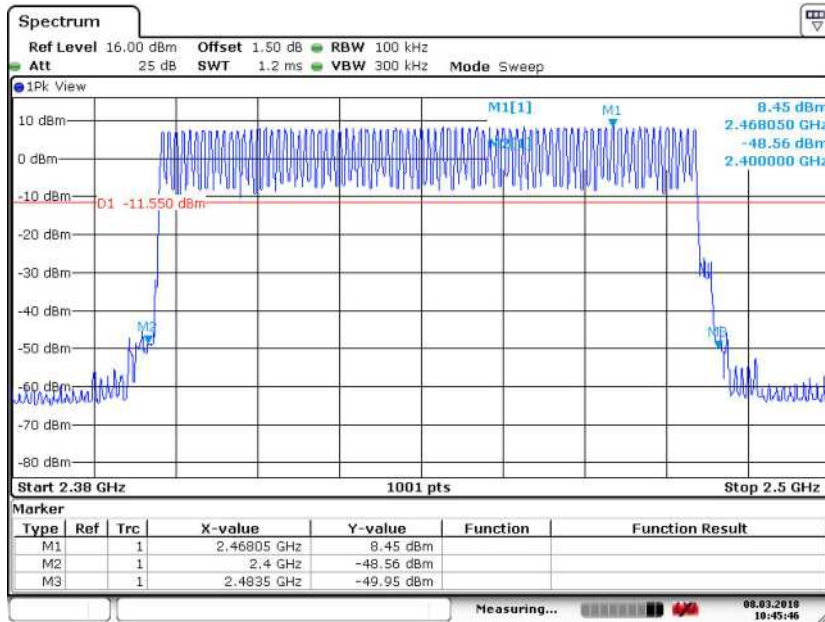
Hopping ON

Date: 8 MAR 2018 10:45:46

Test Plot of 100kHz Bandwidth of Frequency Band Edge, 8DPSK modulation

Low Channel

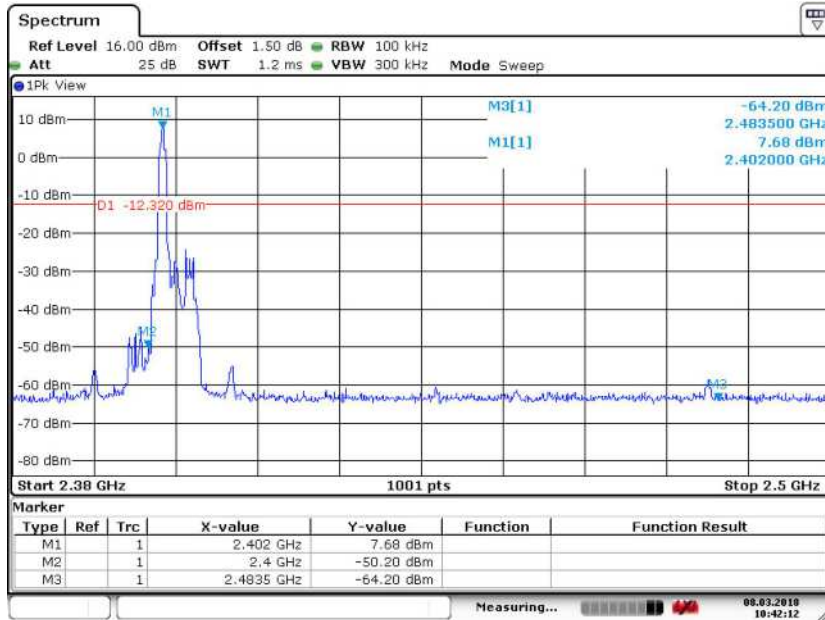

Date: 8.MAR.2018 10:42:12

High Channel

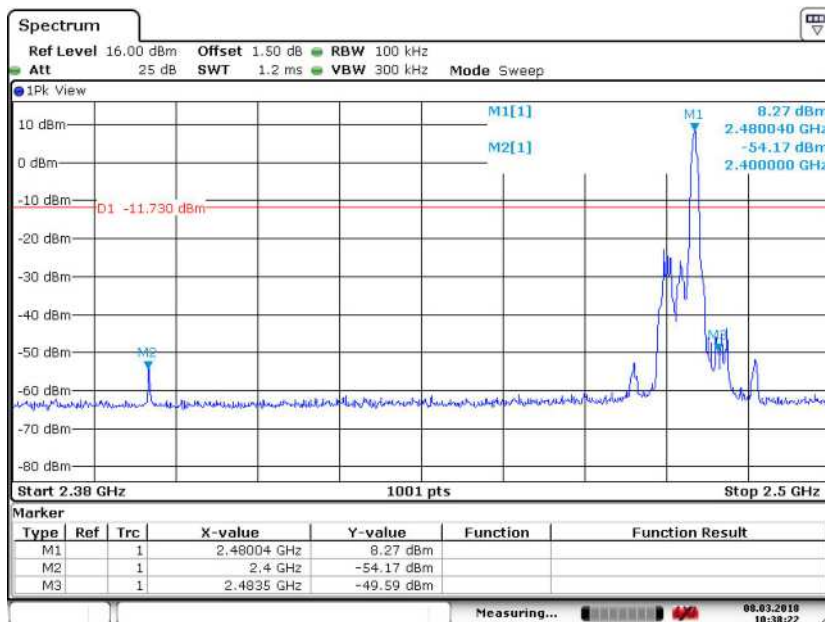

Date: 8.MAR.2018 10:38:22

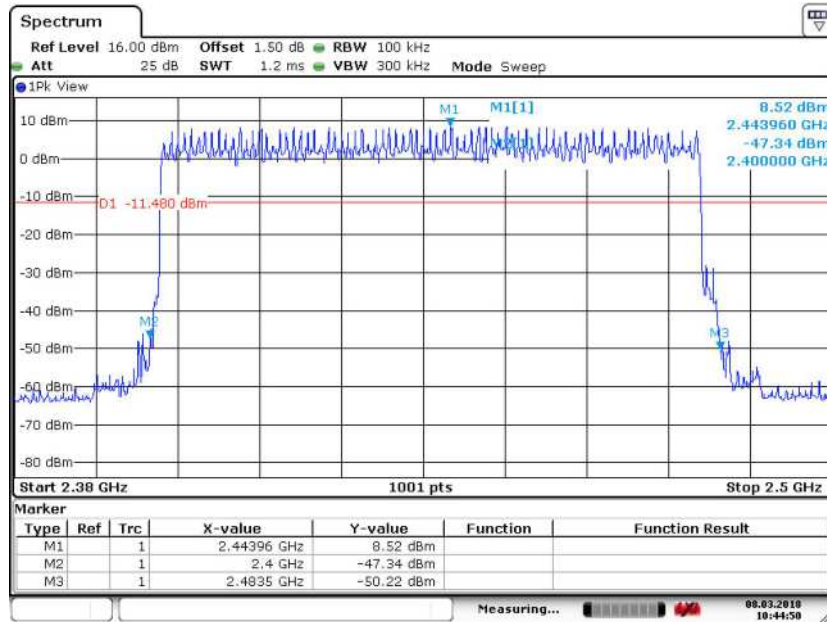
Hopping ON

Date: 8 MAR 2018 10:44:50

5.1.6 Spurious Emission

RESULT:**Passed**

Test standard	:	FCC part 15.247(d), FCC 15.205, FCC 15.209, RSS-247 5.5 and RSS-Gen 8.9 LP0002(2016): 3.10.1.5
Basic standard	:	ANSI C63.10
Limits	:	Radiated emissions which fall in the restricted bands, as defined in FCC 15.205(a) and RSS-Gen i5, 8.10 (Table 7), must comply with the radiated emission limits specified in FCC 15.209(a) and RSS-Gen i5, 8.9 (Table 5 and 6). Radiated emissions which fall in the restricted bands, as defined in LP0002(2016): 2.7 , must comply with the radiated emission limits specified in LP0002(2016): 2.8 Emission radiated outside the specified frequency bands must comply with the radiated emission limits specified in FCC 15.209(a) and FCC 15.249(a), RSS-Gen i5, 8.9 (Table 5 and 6). Emission radiated outside the specified frequency bands must comply with the radiated emission limits specified in LP0002(2016): 2.8
Kind of test site	:	3m Semi-Anechoic Chamber

Test setup

Test Channel	:	Low/ Middle/ High
Operation Mode	:	A, B

For details refer to Appendix D.

The Radiated Emissions testing was performed in the X, Y and Z axis orientation. The worst-case Axis orientation is recorded in this test report.

5.1.7 Frequency Separation

RESULT:
Passed

Test standard : FCC part 15.247(a)(1)
 RSS-247 5.1
 LP0002(2016): 3.10.1.6 (1) (A)
 Basic standard : ANSI C63.10:2013
 LP0002(2016) Appendix II
 Limit : $\geq 25\text{kHz}$ or $2/3$ of 20dB bandwidth, whichever is greater

Test setup

Test Channel : Middle
 Operation Mode : A
 Ambient temperature : 24°C
 Relative humidity : 53%

Table 14: Test result of Frequency Separation (GFSK)

Channel	Channel Frequency (MHz)	Measured Channel Separation (MHz)	Limit (kHz)	Result
Record Channel	2440	1	$\geq 25\text{kHz}$ or $2/3$ of 20dB bandwidth	Pass
Record Channel adj 1	2441			
Record Channel adj 2	2442			

Table 15: Test result of Frequency Separation (8DPSK)

Channel	Channel Frequency (MHz)	Measured Channel Separation (MHz)	Limit (kHz)	Result
Record Channel	2440	1	$\geq 25\text{kHz}$ or $2/3$ of 20dB bandwidth	Pass
Record Channel adj 1	2441			
Record Channel adj 2	2442			

Test Plot of Frequency Separation

GFSK

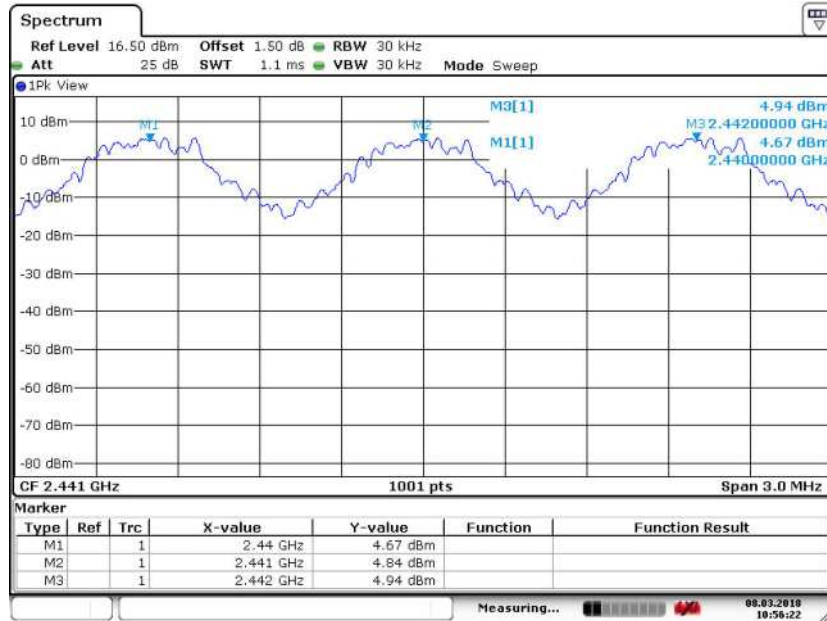

Date: 8. MAR.2018 10:56:23

8DPSK

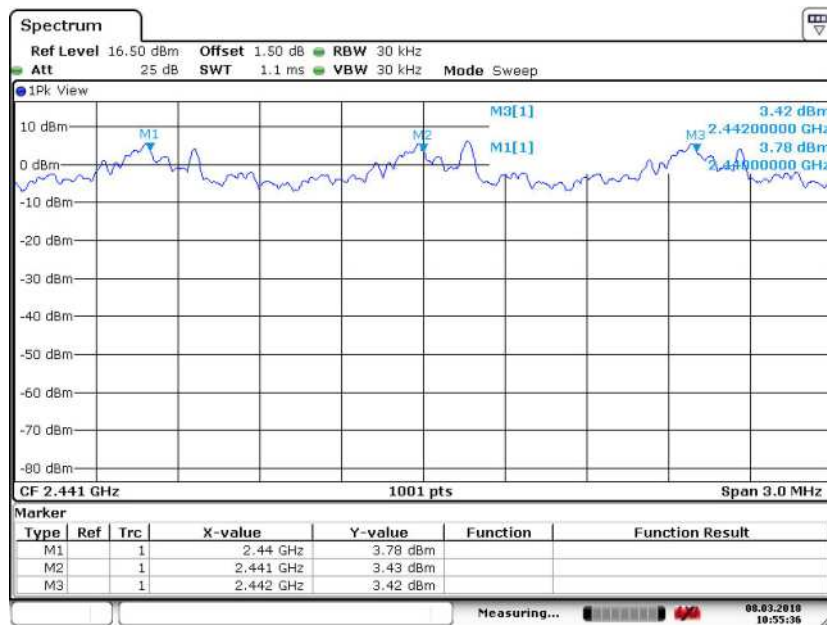

Date: 8. MAR.2018 10:55:36

5.1.8 Number of hopping frequency

RESULT:**Passed**

Test standard : FCC part 15.247(a)(1)(iii)
RSS-247 5.1(5)
LP0002(2016): 3.10.1.6 (1) (A) (a)

Basic standard : ANSI C63.10:2013
LP0002(2016) Appendix II

Test setup

Test Channel : Hopping On

Ambient temperature : 22-26°C
Relative humidity : 50-65%
Atmospheric pressure : 100-103 kPa

Table 16: Test result of Number of hopping frequency

Frequency Range	Measured Quantity of Hopping Channel	Limit	Result
<u>2400</u> to <u>2483.5</u> MHz	79	≥15	Pass

Test Plot of Number of hopping frequencies

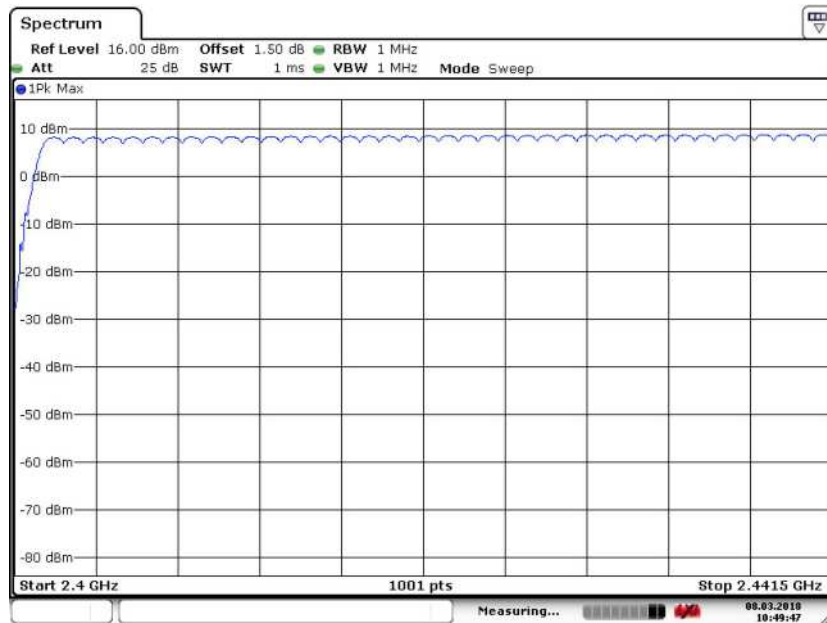
GFSK

Date: 8. MAR.2018 10:49:48

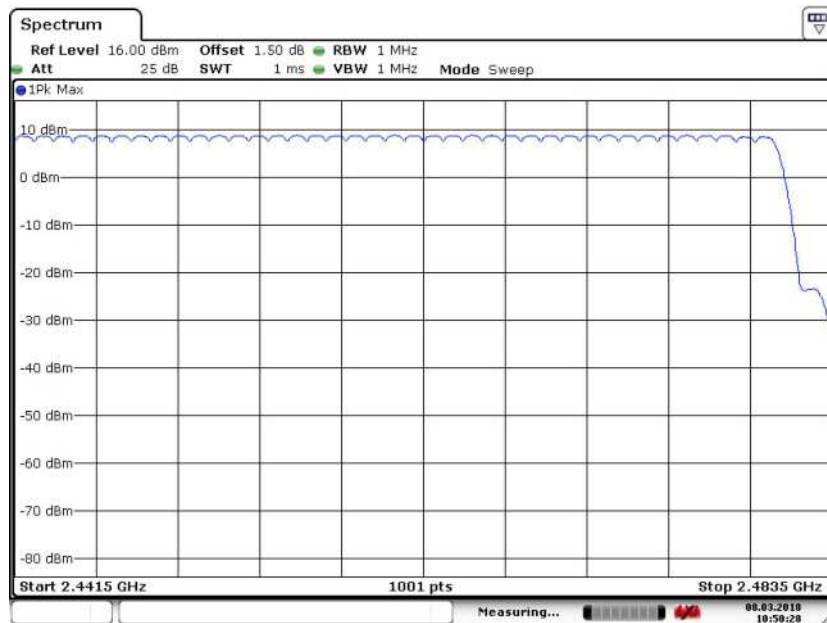

Date: 8. MAR.2018 10:50:29

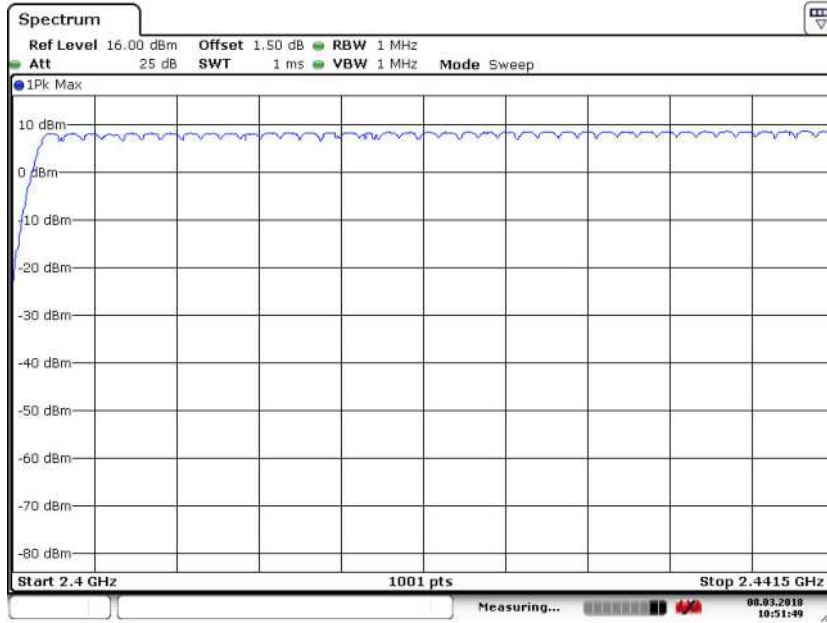
8DPSK

Date: 8.MAR.2018 10:51:49

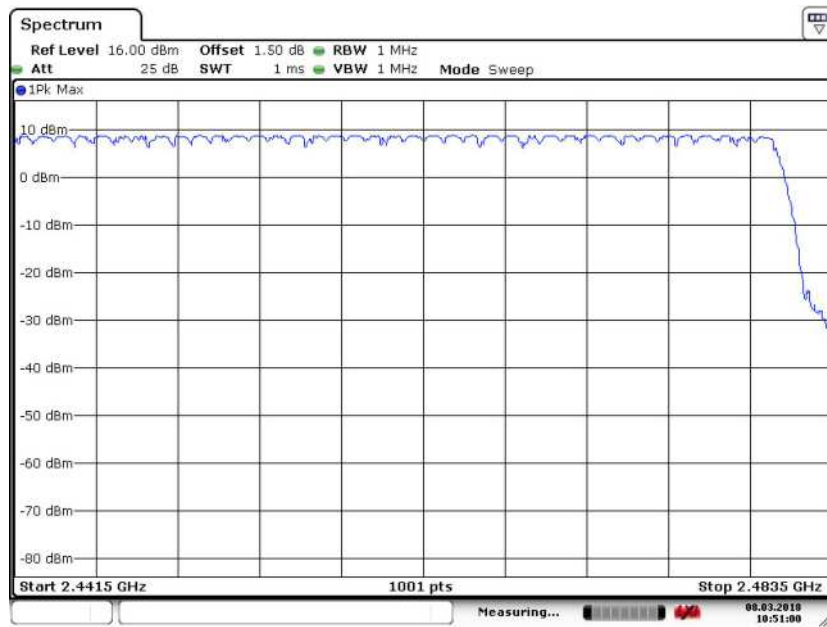

Date: 8.MAR.2018 10:51:00

5.1.9 Time of Occupancy

RESULT:
Passed

Test standard : FCC part 15.247(a)(1)(iii)
 RSS-247 5.1(5)
 LP0002(2016): 3.10.1.6 (1) (A) (a)
 Basic standard : ANSI C63.10:2013
 LP0002(2016) Appendix II
 Limits : 0.4s
 Kind of test site : Shield room

Test setup

Test Channel : Low/ Middle/ High
 Operation Mode : A
 Ambient temperature : 22-26°C
 Relative humidity : 50-65%
 Atmospheric pressure : 100-103 kPa

Table 17: Test result of Time of Occupancy

Data Mode	Captured Burst (s)	Dwell time (s)	On+Off time (s)	Limit (s)	Result
DH5	0.00291	0.3104	0.00375	0.4	Pass
3DH5	0.00296	0.3141	0.00377	0.4	Pass

Note:

$$\text{Dwell time} = \text{Pulse width} \times (\text{Hopping rate} / \text{Number of channels}) \times \text{Period}$$

$$\text{Period} = 0.4 \text{ (seconds/ channel)} \times 79 \text{ (channel)} = 31.6 \text{ seconds.}$$

$$\text{Hopping rate} = 1 / (\text{On+Off time}) = 266 \text{ Hz}$$

Test Plot of Time of Occupancy, GFSK modulation

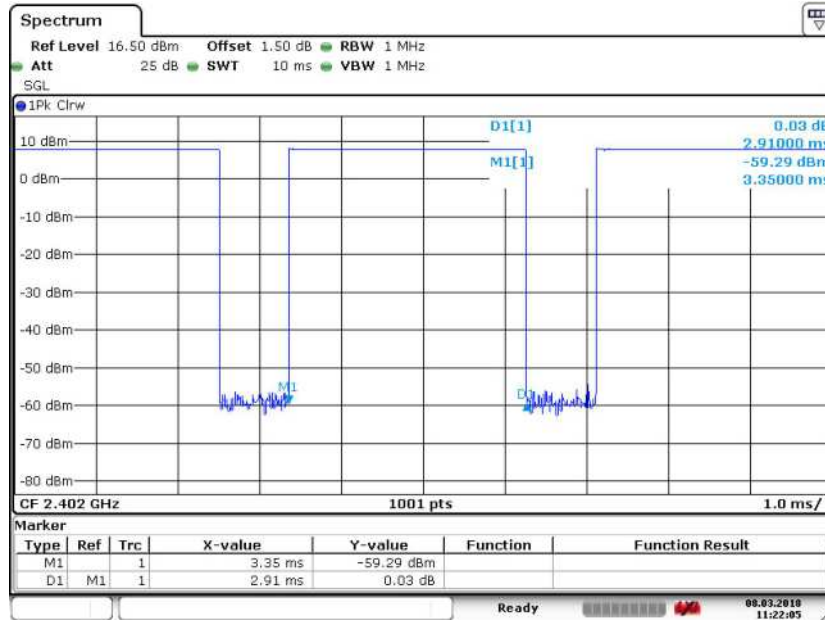

Date: 8 MAR 2018 11:22:05

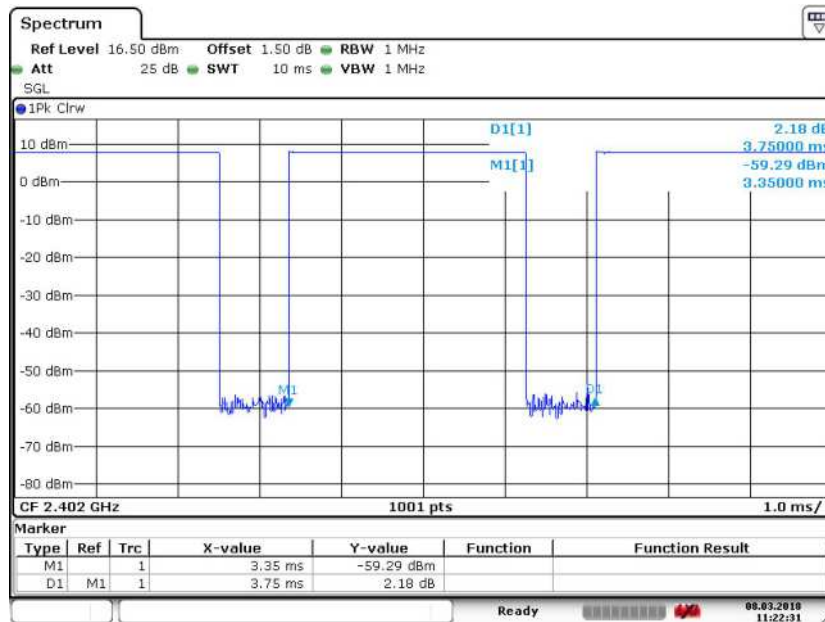

Date: 8 MAR 2018 11:22:31

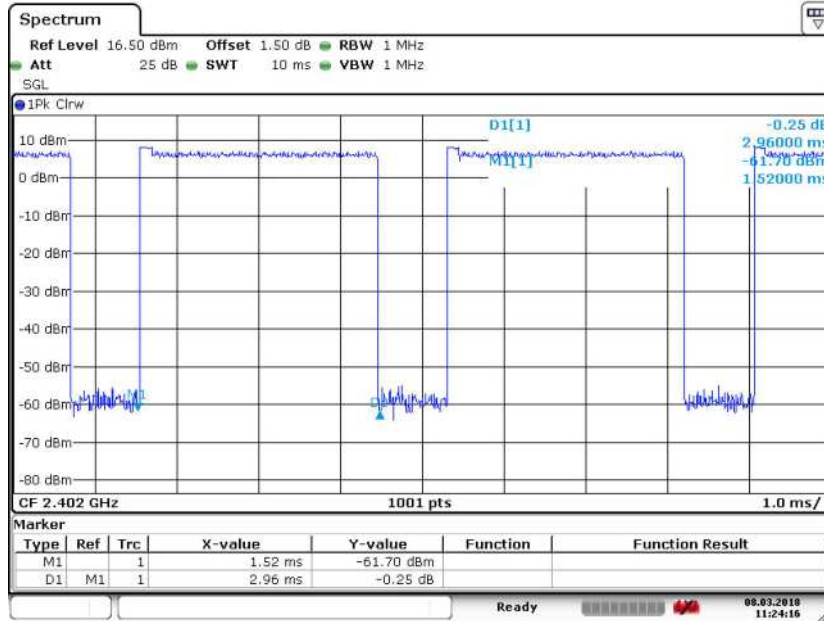
Test Plot of Time of Occupancy, 8DPSK modulation

Date: 8.MAR.2018 11:24:16

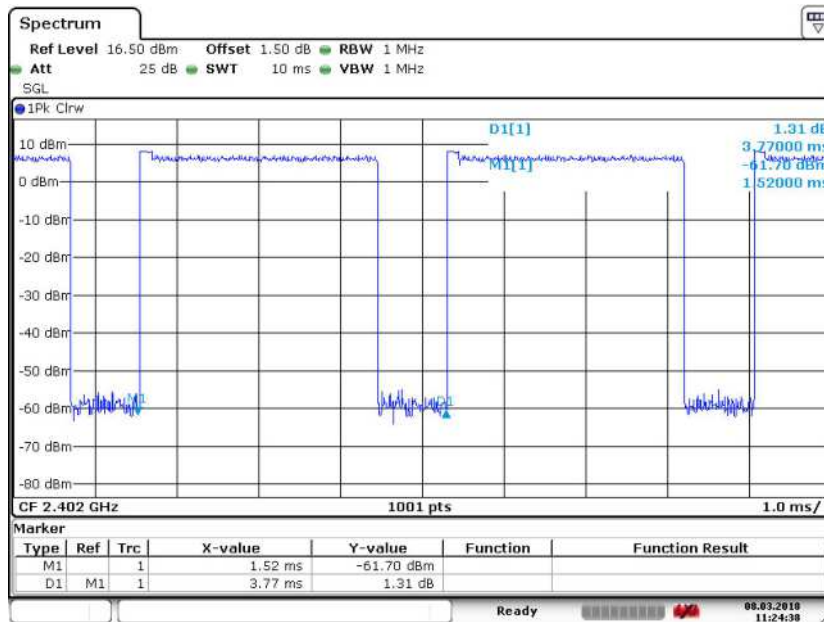

Date: 8.MAR.2018 11:24:38

5.2 Mains Emissions

5.2.1 Mains Conducted Emissions

RESULT:**Passed**

Test standard	:	FCC Part 15.207 FCC Part 15.107 RSS-Gen 8.8 LP0002: 2.3
Limits	:	Mains Conducted emissions as defined in above test standards must comply with the mains conducted emission limits specified
Kind of test site	:	Shielded Room

Test setup

Test Channel	:	Middle
Operation mode	:	A

Remark: For details refer to Appendix D.

6. Safety Human exposure

6.1 Radio Frequency Exposure Compliance

6.1.1 Electromagnetic Fields

RESULT:**Passed**

Test standard : FCC KDB Publication 447498 D01 v06
47CFR 1.1310
47CFR 2.1091
RSS-102 issue 5, Table 4

FCC:

Therefore the maximum output power of the transmitter is 8.77mW < 396mW (Distance: 80 mm), hence the EUT is excluded from SAR evaluation according to FCC KDB publication 447498 D01: Mobile Portable RF Exposure.

Canada:

Maximum conducted peak power: 8.77 mW
Antenna Gain: 5 dbi
Maximum EIRP available 27.7 mW

Since maximum output power of the transmitter is 27.7mW < 309mW (distance ≥50 mm), hence the EUT is excluded from SAR evaluation according to Table 1 in RSS-102

---End---

7. Photographs of the Test Set-Up

Photograph 1: Set-up for Spurious Emissions (Front View 1)- RFA-02-5-C7H1-ANT

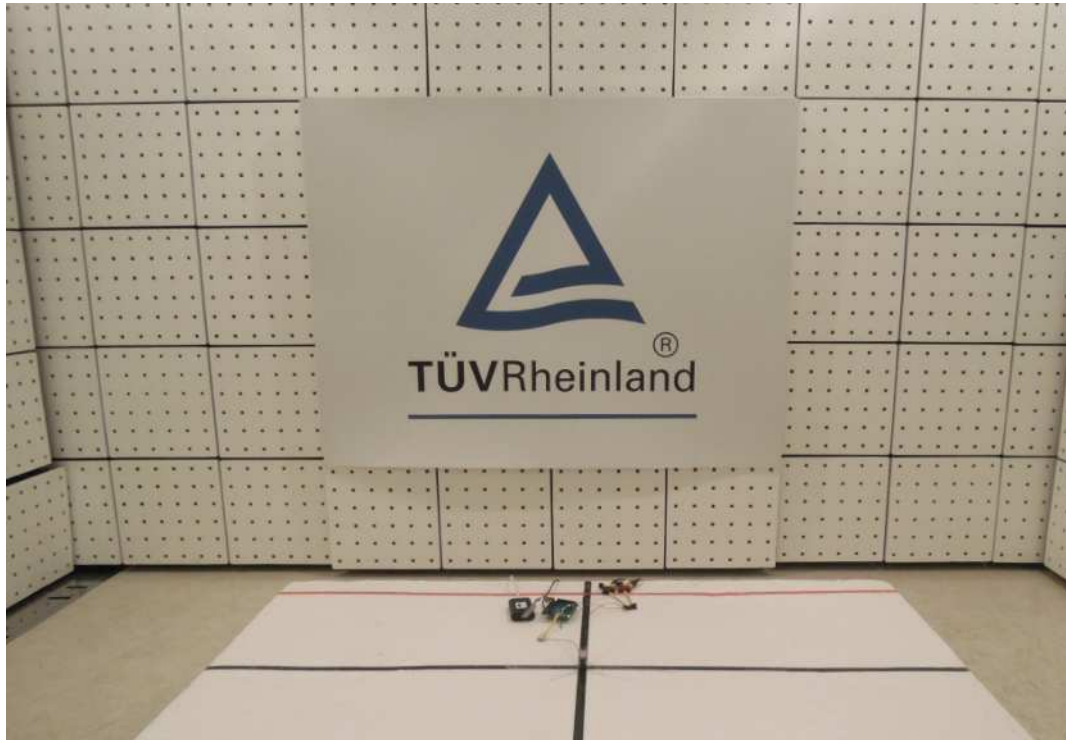

Photograph 2: Set-up for Spurious Emissions (Back View 1)- RFA-02-5-C7H1-ANT

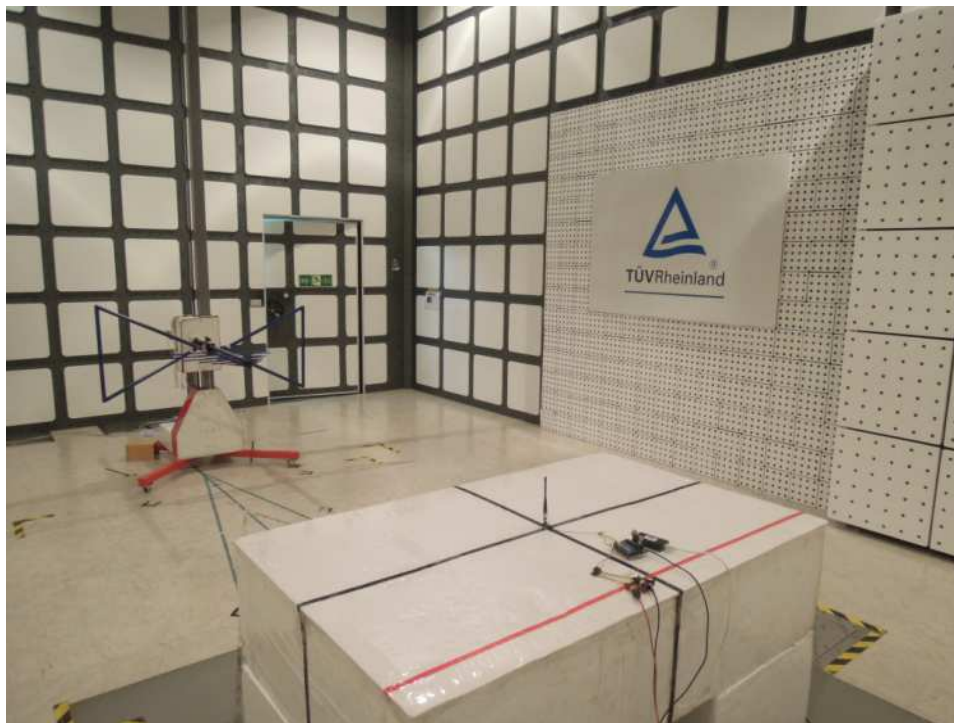

Photograph 3: Set-up for Spurious Emissions (Front View 2)- RFA-02-5-C7H1-ANT

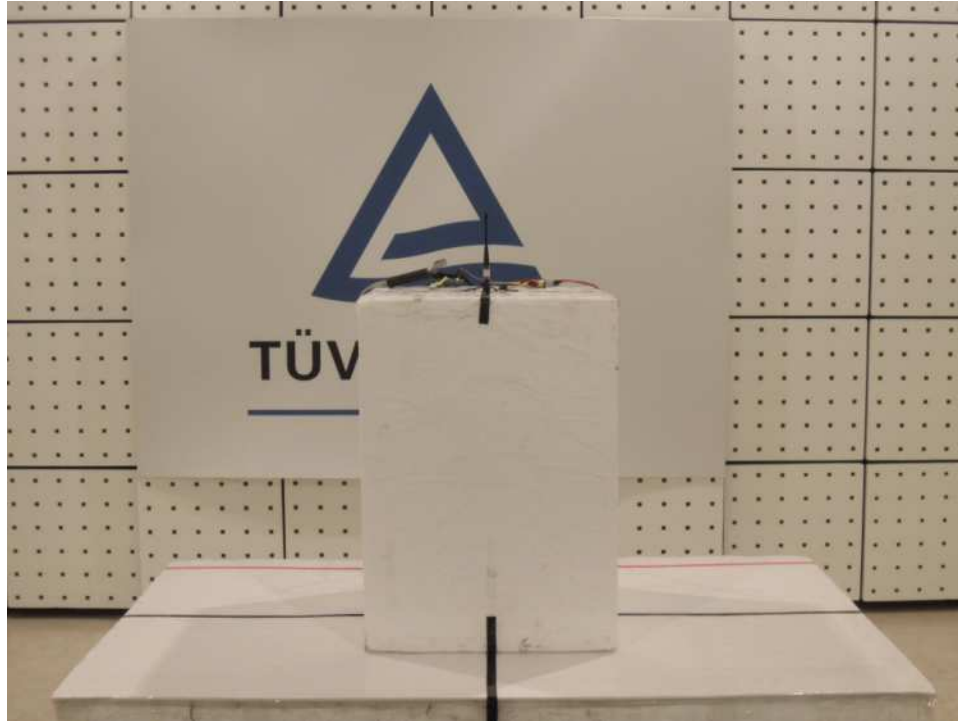

Photograph 4: Set-up for Spurious Emissions (Back View 2)- RFA-02-5-C7H1-ANT



Photograph 5: Set-up for Spurious Emissions (Back View 3)- RFA-02-5-C7H1-ANT

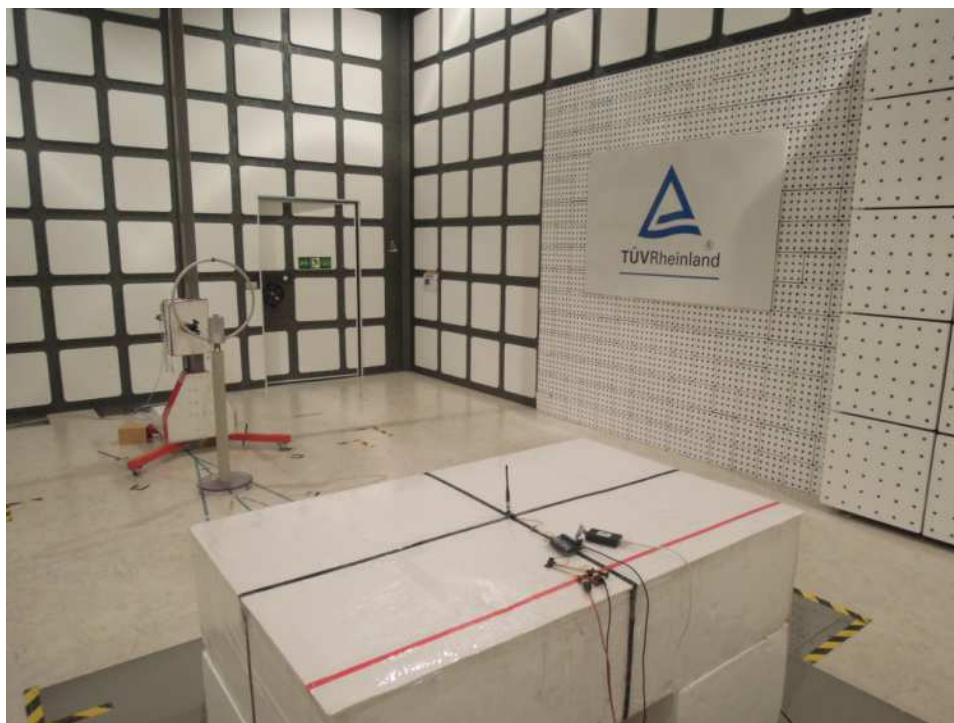

Photograph 6: Set-up for Spurious Emissions (Back View 4)- RFA-02-5-C7H1-ANT

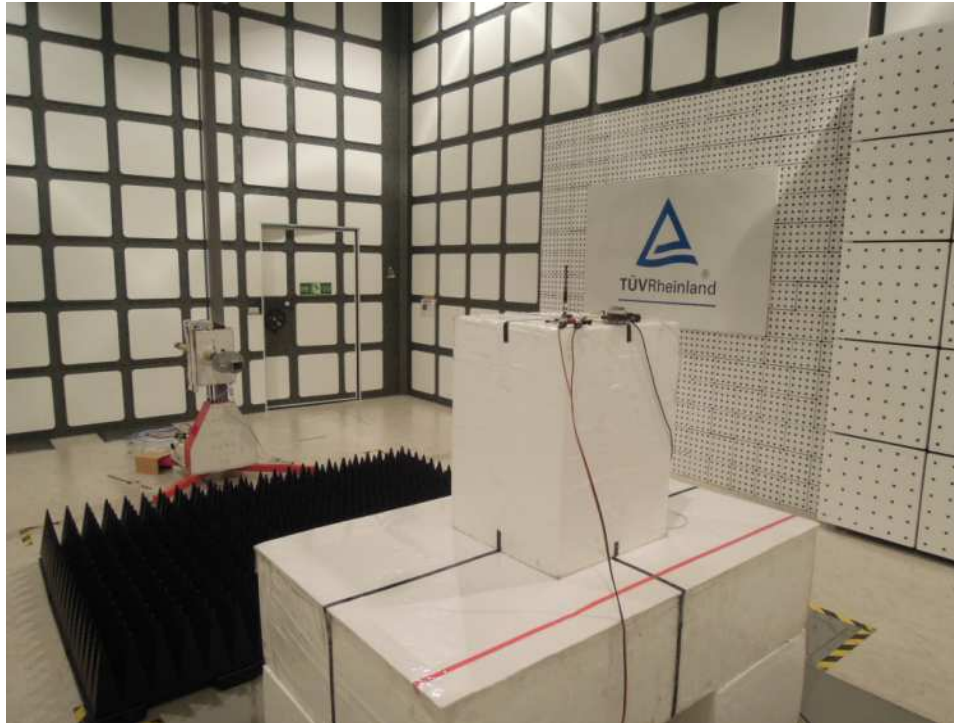

Photograph 7: Set-up for Spurious Emissions (Front View 1)- RFMTA331215-ANT

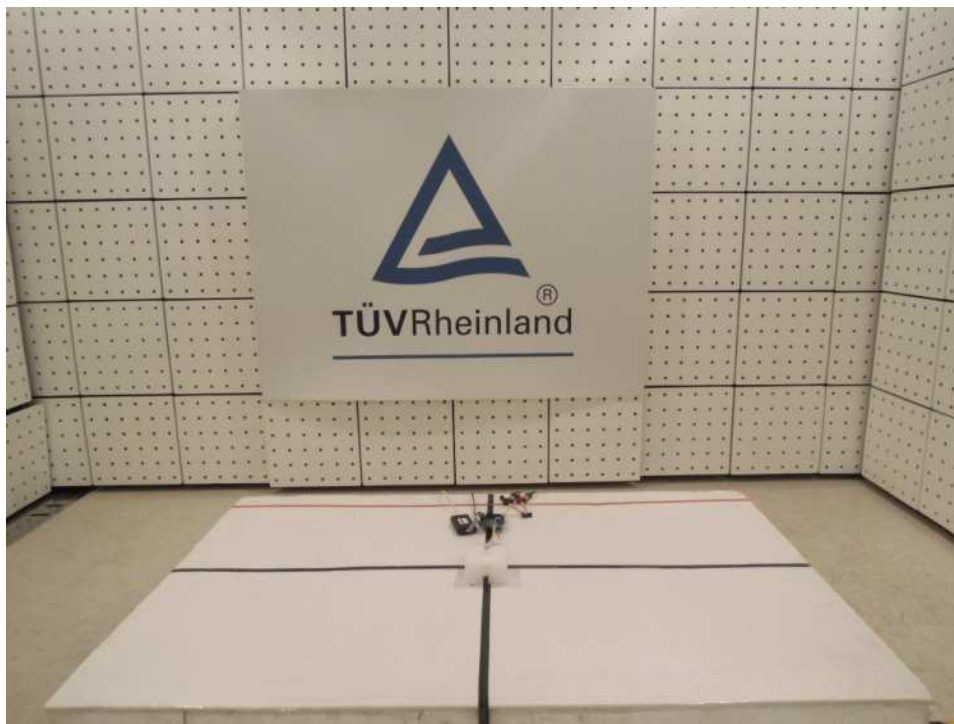

Photograph 8: Set-up for Spurious Emissions (Back View 1)- RFMTA331215-ANT

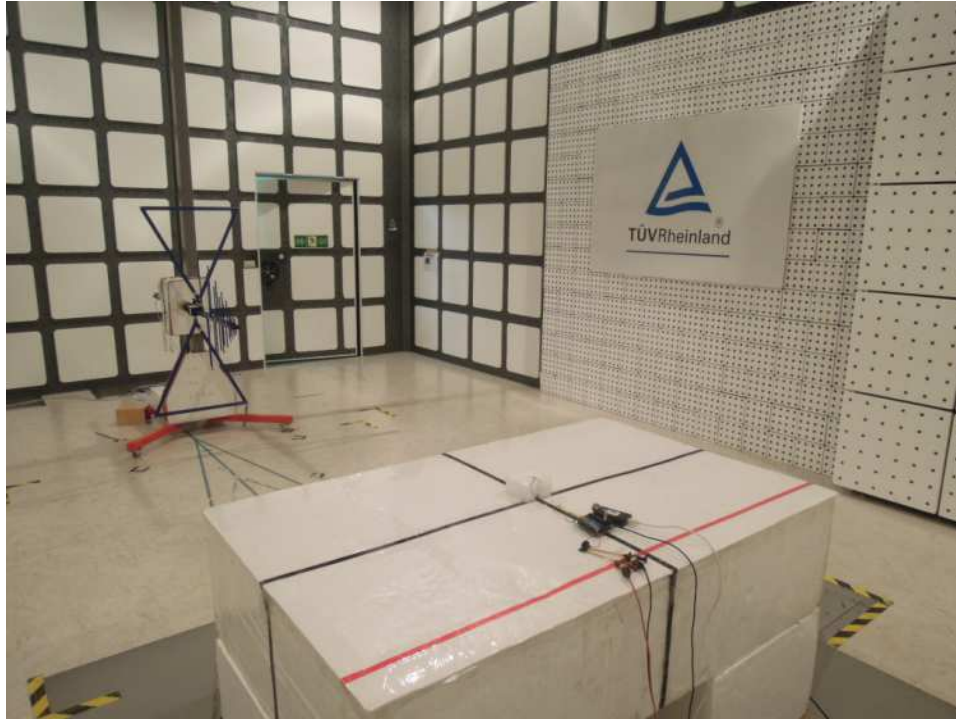

Photograph 9: Set-up for Spurious Emissions (Front View 2)- RFMTA331215-ANT

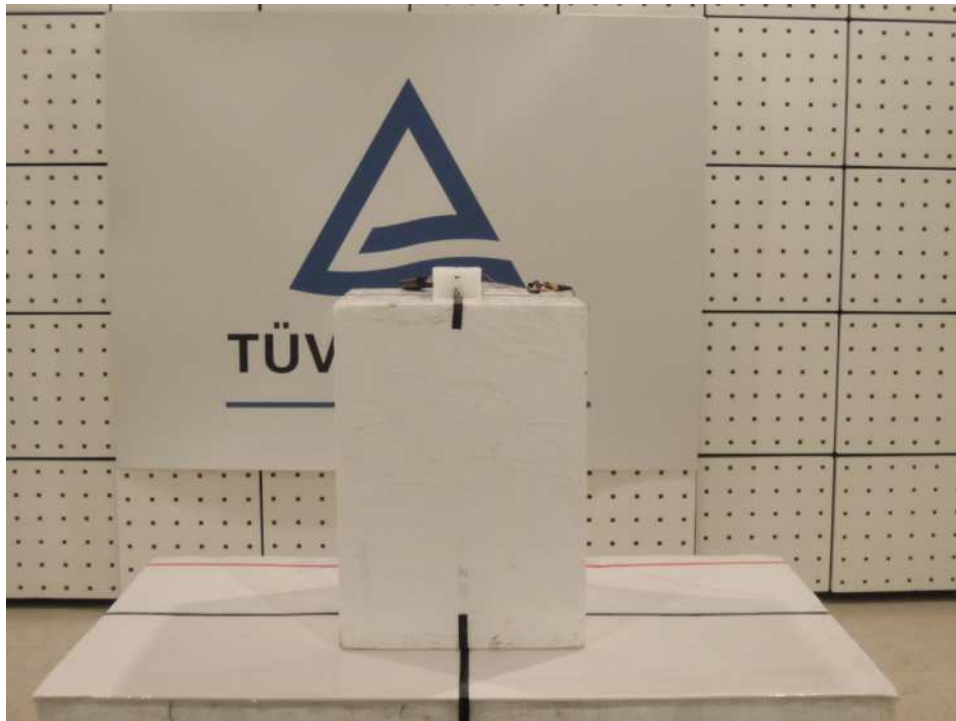

Photograph 10: Set-up for Spurious Emissions (Back View 2)- RFMTA331215-ANT

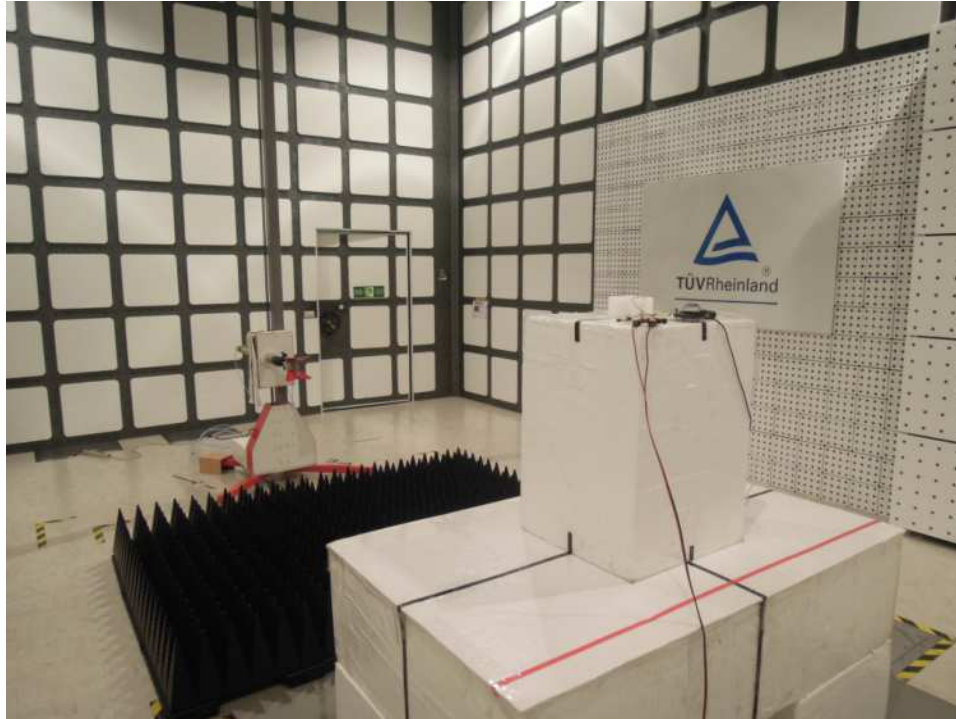

Photograph 11: Set-up for Spurious Emissions (Back View 3)- RFMTA331215-ANT

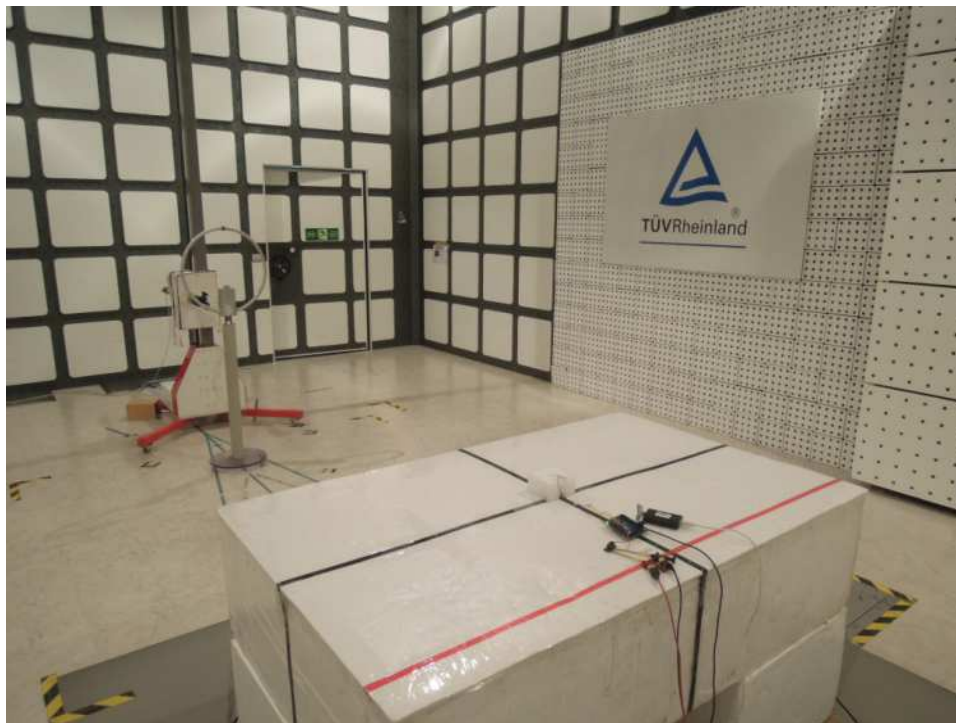

Photograph 12: Set-up for Spurious Emissions (Back View 4)- RFMTA331215-ANT



Photograph 13: Set-up for Spurious Emissions (Front View 1)- RFPCA381013IMAB701-ANT

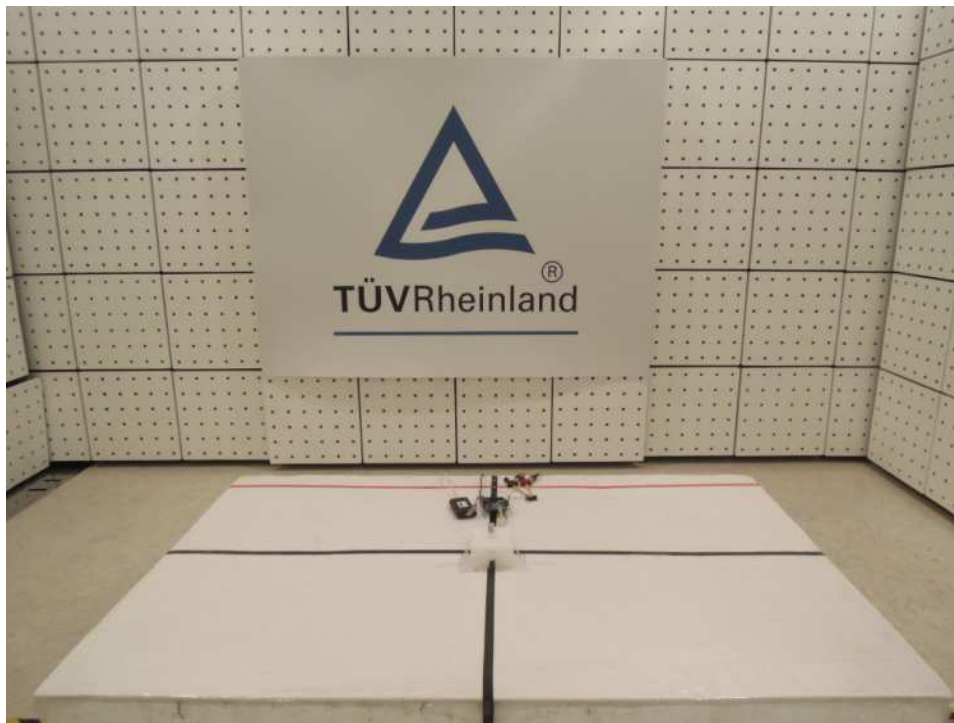

Photograph 14: Set-up for Spurious Emissions (Back View 1)- RFPCA381013IMAB701-ANT

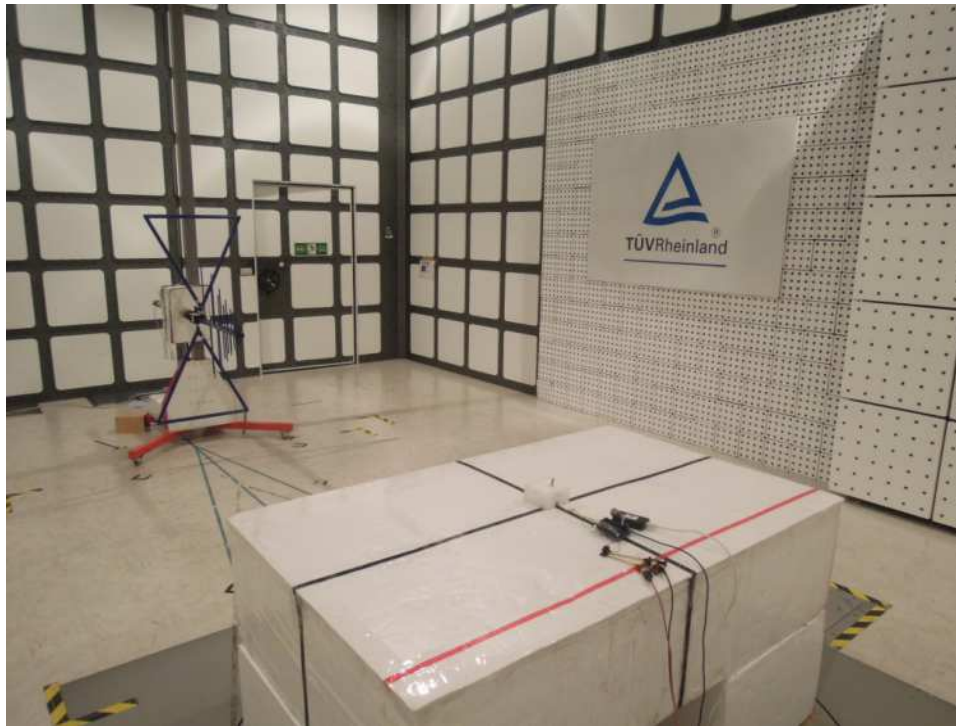

Photograph 15: Set-up for Spurious Emissions (Front View 2)- RFPCA381013IMAB701-ANT

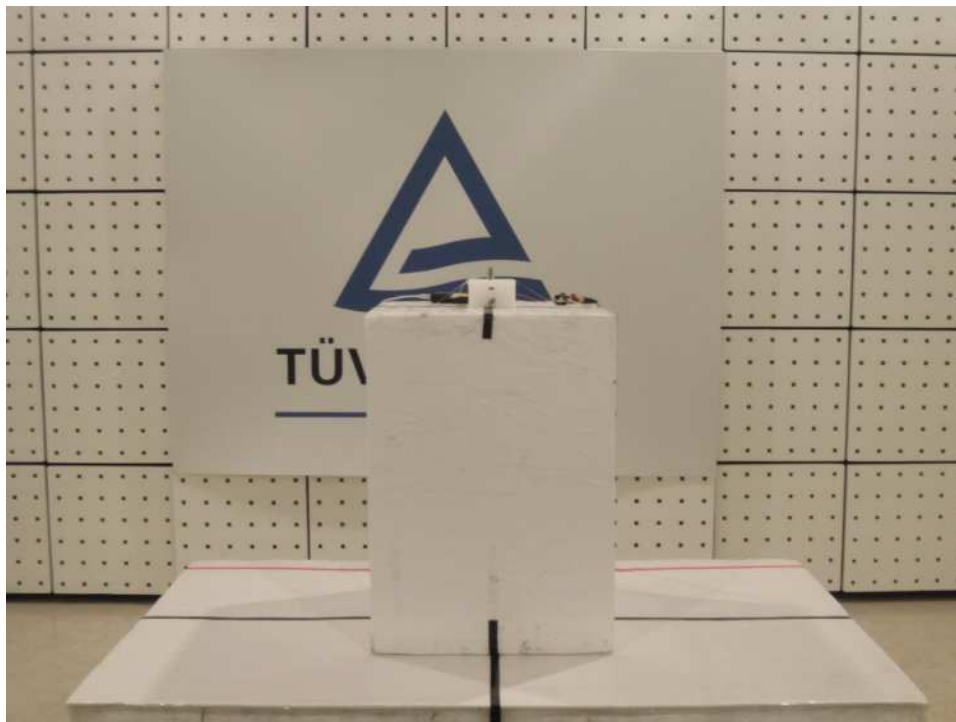

Photograph 16: Set-up for Spurious Emissions (Back View 2)- RFPCA381013IMAB701-ANT



Photograph 17: Set-up for Spurious Emissions (Back View 3)- RFPCA381013IMAB701-ANT

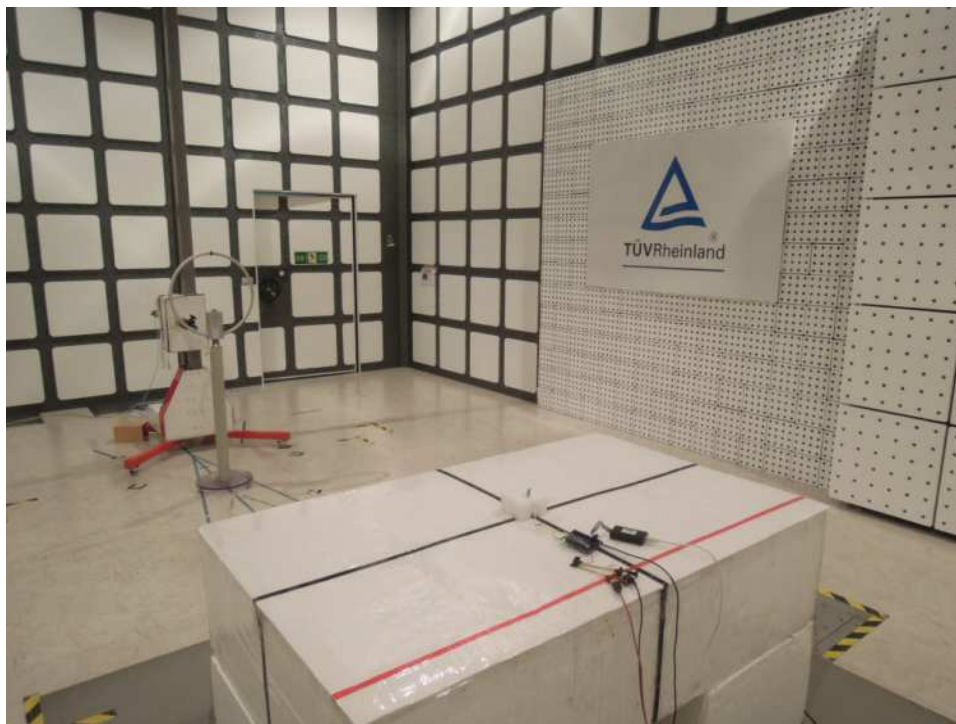

Photograph 18: Set-up for Spurious Emissions (Back View 4)- RFPCA381013IMAB701-ANT

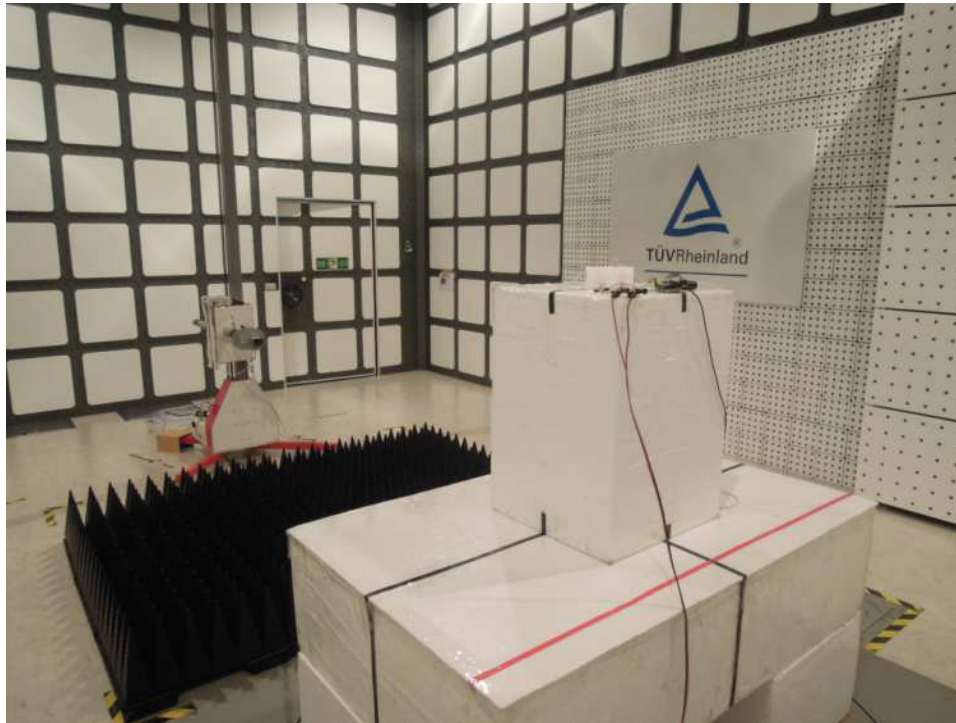

Photograph 19: Set-up for Conducted testing



Photograph 20: Set-up for Conducted testing



Photograph 21: Set-up for Mains Conducted testing (Front View)



Photograph 22: Set-up for Mains Conducted testing (Back View)



8. List of Tables

Table 1: Applied Standard and Test Levels	5
Table 2: List of Test and Measurement Equipment	7
Table 3: Emission Measurement Uncertainty.....	8
Table 4: Basic Information of EUT	9
Table 5: Technical Specification of EUT	9
Table 6: External Antenna list.....	10
Table 7: Frequency hopping information.....	11
Table 8: Test result of Peak Output Power, GFSK modulation.....	17
Table 9: Test result of Peak Output Power, 8DPSK modulation.....	17
Table 10: Test result of 20dB Bandwidth, GFSK modulation.....	18
Table 11: Test result of 20dB Bandwidth, 8DPSK modulation.....	18
Table 12: Test result of 99% Bandwidth, GFSK modulation.....	22
Table 13: Test result of 99% Bandwidth, PSK modulation.....	22
Table 14: Test result of Frequency Separation (GFSK).....	35
Table 15: Test result of Frequency Separation (8DPSK).....	35
Table 16: Test result of Number of hopping frequency.....	37
Table 17: Test result of Time of Occupancy.....	40

9. List of Photographs

Photograph 1: Set-up for Spurious Emissions (Front View 1)- RFA-02-5-C7H1-ANT	45
Photograph 2: Set-up for Spurious Emissions (Back View 1)- RFA-02-5-C7H1-ANT	45
Photograph 3: Set-up for Spurious Emissions (Front View 2)- RFA-02-5-C7H1-ANT	46
Photograph 4: Set-up for Spurious Emissions (Back View 2)- RFA-02-5-C7H1-ANT	47
Photograph 5: Set-up for Spurious Emissions (Back View 3)- RFA-02-5-C7H1-ANT	47
Photograph 6: Set-up for Spurious Emissions (Back View 4)- RFA-02-5-C7H1-ANT	48
Photograph 7: Set-up for Spurious Emissions (Front View 1)- RFMTA331215-ANT	48
Photograph 8: Set-up for Spurious Emissions (Back View 1)- RFMTA331215-ANT	49
Photograph 9: Set-up for Spurious Emissions (Front View 2)- RFMTA331215-ANT	49
Photograph 10: Set-up for Spurious Emissions (Back View 2)- RFMTA331215-ANT	50
Photograph 11: Set-up for Spurious Emissions (Back View 3)- RFMTA331215-ANT	50
Photograph 12: Set-up for Spurious Emissions (Back View 4)- RFMTA331215-ANT	51
Photograph 13: Set-up for Spurious Emissions (Front View 1)- RFPCA381013IMAB701-ANT	51
Photograph 14: Set-up for Spurious Emissions (Back View 1)- RFPCA381013IMAB701-ANT	52
Photograph 15: Set-up for Spurious Emissions (Front View 2)- RFPCA381013IMAB701-ANT	52
Photograph 16: Set-up for Spurious Emissions (Back View 2)- RFPCA381013IMAB701-ANT	53
Photograph 17: Set-up for Spurious Emissions (Back View 3)- RFPCA381013IMAB701-ANT	53
Photograph 18: Set-up for Spurious Emissions (Back View 4)- RFPCA381013IMAB701-ANT	54
Photograph 19: Set-up for Conducted testing	54
Photograph 20: Set-up for Conducted testing	55
Photograph 21: Set-up for Mains Conducted testing (Front View).....	55
Photograph 22: Set-up for Mains Conducted testing (Back View).....	56