



Prüfbericht-Nr.: <i>Test report no.:</i>	CN242VUR 001	Auftrags-Nr.: <i>Order no.:</i>	48225375	Seite 1 von 35 Page 1 of 35
Kunden-Referenz-Nr.: <i>Client reference no.:</i>	N/A	Auftragsdatum: <i>Order date:</i>	2023-12-28	
Auftraggeber: <i>Client:</i>	Microchip Technology Inc. 2355 West Chandler Blvd. Chandler, Arizona 85224-6199, United States			
Prüfgegenstand: <i>Test item:</i>	Wireless MCU module with BLE 5.2 compliant and Zigbee 3.0 Radio			
Bezeichnung / Typ-Nr.: <i>Identification / Type no.:</i>	WBZ451HPE, WBZ451HUE			
Auftrags-Inhalt: <i>Order content:</i>	FCC Part 15C Test report (ZigBee)			
Prüfgrundlage: <i>Test specification:</i>	FCC 47CFR Part 15: Subpart C Section 15.247			
Wareneingangsdatum: <i>Date of sample receipt:</i>	2023-10-26			
Prüfmuster-Nr.: <i>Test sample no.:</i>	A003589924-008 & 009 A003589924-011 A003119783-009 A003130881-021 A003589924-010			
Prüfzeitraum: <i>Testing period:</i>	2023-12-08 - 2024-02-20			
Ort der Prüfung: <i>Place of testing:</i>	EMC/RF Taipei Testing Site			
Prüflaboratorium: <i>Testing laboratory:</i>	Taipei Testing Laboratories			
Prüfergebnis*: <i>Test result*:</i>	Pass			
zusammengestellt von: <i>compiled by:</i>			genehmigt von: <i>authorized by:</i>	
Datum: <i>Date:</i>	2024-03-12	Ausstellungsdatum: <i>Issue date:</i>	2024-03-12	
Stellung / Position:	David Huang Project Manager	Stellung / Position:	Brenda Chen Senior Project Manager	
Sonstiges / Other:				
Zustand des Prüfgegenstandes bei Anlieferung: <i>Condition of the test item at delivery:</i>	Prüfmuster vollständig und unbeschädigt <i>Test item complete and undamaged</i>			
* Legende:	1 = sehr gut P(ass) = entspricht o.g. Prüfgrundlage(n)	2 = gut F(ail) = entspricht nicht o.g. Prüfgrundlage(n)	3 = befriedigend N/A = nicht anwendbar	4 = ausreichend N/T = nicht getestet
* Legend:	1 = very good P(ass) = passed a.m. test specification(s)	2 = good F(ail) = failed a.m. test specification(s)	3 = satisfactory N/A = not applicable	4 = sufficient N/T = not tested
Dieser Prüfbericht bezieht sich nur auf das o.g. Prüfmuster und darf ohne Genehmigung der Prüfstelle nicht auszugsweise vervielfältigt werden. Dieser Bericht berechtigt nicht zur Verwendung eines Prüfzeichens. <i>This test report only relates to the a. m. test sample. Without permission of the test center this test report is not permitted to be duplicated in extracts. This test report does not entitle to carry any test mark.</i>				

Prüfbericht-Nr.:
Test report no.:

CN242VUR 001

Seite 2 von 35
Page 2 of 35

Anmerkungen
Remarks

1	<p>Alle eingesetzten Prüfmittel waren zum angegebenen Prüfzeitraum gemäß eines festgelegten Kalibrierungsprogramms unseres Prüfhauses kalibriert. Sie entsprechen den in den Prüfprogrammen hinterlegten Anforderungen. Die Rückverfolgbarkeit der eingesetzten Prüfmittel ist durch die Einhaltung der Regelungen unseres Managementsystems gegeben. Detaillierte Informationen bezüglich Prüfkonditionen, Prüfequipment und Messunsicherheiten sind im Prüflabor vorhanden und können auf Wunsch bereitgestellt werden.</p> <p><i>The equipment used during the specified testing period was calibrated according to our test laboratory calibration program. The equipment fulfils the requirements included in the relevant standards. The traceability of the test equipment used is ensured by compliance with the regulations of our management system. Detailed information regarding test conditions, equipment and measurement uncertainty is available in the test laboratory and could be provided on request.</i></p>
2	<p>Wie vertraglich vereinbart, wurde dieses Dokument nur digital unterzeichnet. Der TÜV Rheinland hat nicht überprüft, welche rechtlichen oder sonstigen diesbezüglichen Anforderungen für dieses Dokument gelten. Diese Überprüfung liegt in der Verantwortung des Benutzers dieses Dokuments. Auf Verlangen des Kunden kann der TÜV Rheinland die Gültigkeit der digitalen Signatur durch ein gesondertes Dokument bestätigen. Diese Anfrage ist an unseren Vertrieb zu richten. Eine Umweltgebühr für einen solchen zusätzlichen Service wird erhoben. Informationen zur Verifizierung der Authentizität unserer Dokumente erhalten Sie auf folgender Webseite: go.tuv.com/digital-signature</p> <p><i>As contractually agreed, this document has been signed digitally only. TUV Rheinland has not verified and unable to verify which legal or other pertaining requirements are applicable for this document. Such verification is within the responsibility of the user of this document. Upon request by its client, TUV Rheinland can confirm the validity of the digital signature by a separate document. Such request shall be addressed to our Sales department. An environmental fee for such additional service will be charged. For information on verifying the authenticity of our documents, please visit the following website: go.tuv.com/digital-signature</i></p>
3	<p>Prüfklausel mit der Note * wurden an qualifizierte Unterauftragnehmer vergeben und sind unter der jeweiligen Prüfklausel des Berichts beschrieben. Abweichungen von Prüfspezifikation(en) oder Kundenanforderungen sind in der jeweiligen Prüfklausel im Bericht aufgeführt.</p> <p><i>Test clauses with remark of * are subcontracted to qualified subcontractors and described under the respective test clause in the report. Deviations of testing specification(s) or customer requirements are listed in specific test clause in the report.</i></p>
4	<p>Die Entscheidungsregel für Konformitätserklärungen basierend auf numerischen Messergebnissen in diesem Prüfbericht basiert auf der "Null-Grenzwert-Regel" und der "Einfachen Akzeptanz" gemäß ILAC G8:2019 und IEC Guide 115:2021, es sei denn, in der auf Seite 1 dieses Berichts genannten angewandten Norm ist etwas anderes festgelegt oder vom Kunden gewünscht. Dies bedeutet, dass die Messunsicherheit nicht berücksichtigt wird und daher auch nicht im Prüfbericht angegeben wird. Zu weiteren Informationen bezüglich des Risikos durch diese Entscheidungsregel siehe ILAC G8:2019.</p> <p><i>The decision rule for statements of conformity, based on numerical measurement results, in this test report is based on the "Zero Guard Band Rule" and "Simple Acceptance" in accordance with ILAC G8:2019 and IEC Guide 115:2021, unless otherwise specified in the applied standard mentioned on Page 1 of this report or requested by the customer. This means that measurement uncertainty is not taken in account and hence also not declared in the test report. For additional information to the resulting risk based of this decision rule please refer to ILAC G8:2019.</i></p>

Prüfbericht-Nr.: CN242VUR 001
Test report no.:Seite 3 von 35
Page 3 of 35

TEST SUMMARY

Report Section	FCC Clause	Test Item	Result
5.1.1	15.247(b) & 15.203	Antenna Requirement	Pass
5.1.2	15.247(b)(3)	Peak Output Power	Pass
5.1.3	15.247(a)(2)	6 dB Bandwidth	Pass
5.1.3	2.1049	99% Occupied Bandwidth	Pass
5.1.4	15.247(e)	Power Spectral Density	Pass
5.1.5	15.247(d)	Conducted Spurious Emissions and Band Edges	Pass
5.1.6	15.247(d) & 15.205 & 15.209	Radiated Spurious Emissions and Band Edges	Pass
5.2.1	15.207	Mains Conducted Emission	Pass

Note: Determining compliance based on the results of the compliance measurement, not taking into account measurement instrumentation uncertainty.

Prüfbericht-Nr.: CN242VUR 001
Test report no.:

 Seite 4 von 35
 Page 4 of 35

Contents

HISTORY OF THIS TEST REPORT	6
1. GENERAL REMARKS	7
1.1 COMPLEMENTARY MATERIALS.....	7
1.2 DECISION RULE OF CONFORMITY	7
2. TEST SITES	8
2.1 TEST LABORATORY	8
2.2 TEST FACILITY.....	8
2.3 TRACEABILITY	9
2.4 CALIBRATION	9
2.5 MEASUREMENT UNCERTAINTY	9
3. GENERAL PRODUCT INFORMATION.....	10
3.1 PRODUCT FUNCTION AND INTENDED USE	10
3.2 SYSTEM DETAILS AND RATINGS.....	10
3.3 NOISE GENERATING AND NOISE SUPPRESSING PARTS	12
3.4 SUBMITTED DOCUMENTS.....	12
4. TEST SET-UP AND OPERATION MODES	13
4.1 PRINCIPLE OF CONFIGURATION SELECTION	13
4.2 CARRIER FREQUENCY AND CHANNEL.....	13
4.3 TEST OPERATION AND TEST SOFTWARE.....	14
4.4 SPECIAL ACCESSORIES AND AUXILIARY EQUIPMENT	16
4.5 TEST SETUP DIAGRAM	18
5. TEST RESULTS	22
5.1 TRANSMITTER REQUIREMENT & TEST SUITES	22
5.1.1 <i>Antenna Requirement</i>	<i>22</i>
5.1.2 <i>Peak Output Power</i>	<i>23</i>
5.1.3 <i>6 dB Bandwidth and 99% Occupied Bandwidth.....</i>	<i>26</i>
5.1.4 <i>Power Spectral Density.....</i>	<i>27</i>
5.1.5 <i>Conducted Spurious Emissions and Frequency Band Edges Measured in 100kHz Bandwidth</i>	<i>28</i>
5.1.6 <i>Radiated Spurious Emissions and Band Edges</i>	<i>29</i>
5.2 MAINS EMISSION	34
5.2.1 <i>Mains Conducted Emission.....</i>	<i>34</i>

Prüfbericht-Nr.: CN242VUR 001
Test report no.:

Seite 5 von 35
Page 5 of 35

APPENDIX A - TEST RESULT OF CONDUCTED for UFL Antenna

APPENDIX B - TEST RESULT OF RADIATED EMISSIONS & MAINS CONDUCTED EMISSION FOR PCB Antenna

APPENDIX C - TEST RESULT OF RADIATED EMISSIONS & MAINS CONDUCTED EMISSION FOR UFL ANTENNA

APPENDIX SP - PHOTOGRAPHS OF TEST SETUP

APPENDIX EP - PHOTOGRAPHS OF EUT

Prüfbericht-Nr.: **CN242VUR 001**
Test report no.:

Seite 6 von 35
Page 6 of 35

HISTORY OF THIS TEST REPORT

Revision	Description	Date Issued
R01	Original Release	2024-03-12

Prüfbericht-Nr.: **CN242VUR 001**
Test report no.:Seite 7 von 35
Page 7 of 35

1. General Remarks

1.1 Complementary Materials

All attachments are integral parts of this test report. This applies especially to the following appendix:

Appendix A - Test Result of Conducted for UFL Antenna

Appendix B - Test Result of Radiated Emissions & Mains Conducted Emission for PCB Antenna

Appendix C - Test Result of Radiated Emissions & Mains Conducted Emission for UFL Antenna

Appendix SP - Photographs of Test Setup

Appendix EP - Photographs of EUT

Applied Standard and Test Levels

Radio
FCC 47CFR Part 15: Subpart C Section 15.247
FCC 47CFR Part 2: Subpart J Section 2.1049
ANSI C63.10:2013
KDB 558074 D01 15.247 Meas Guidance v05r02

1.2 Decision Rule of Conformity

The decision rule of conformity of this test report is following the requirements of the requested standard in the quotation, and agreed among testing laboratory and manufacturer (applicant) to exclude the consideration of Measurement Uncertainty, unless it is required by the specific standard.

Prüfbericht-Nr.: **CN242VUR 001**
Test report no.:

Seite 8 von 35
Page 8 of 35

2. Test Sites

2.1 Test Laboratory

Taipei Testing Laboratories

11F. No.758, Sec. 4, Bade Rd., Songshan Dist.
Taipei City 105
Taiwan (R.O.C.)

2.2 Test Facility

Taipei Testing Laboratories

No.458-18, Sec. 2, Fenliao Rd., Linkou Dist.,
New Taipei City 244
Taiwan (R.O.C.)
FCC Registration No.: 180491
ISED Registration No.: 25563

Prüfbericht-Nr.: CN242VUR 001
Test report no.:Seite 9 von 35
Page 9 of 35

2.3 Traceability

All measurement equipment calibrations are traceable to NML(Taiwan)/NIST(USA) or where calibration is performed outside Taiwan, to equivalent nationally recognized standards organizations.

2.4 Calibration

Equipment requiring calibration is calibrated periodically in a suitably accredited Calibration Lab. Additionally all equipment is verified for proper performance on a regular basis using in house standards or comparisons.

2.5 Measurement Uncertainty

All measurement uncertainty values are shown with a coverage factor of $k=2$ to indicate a 95% level of confidence.

Emission Measurement Uncertainty

Parameter	Uncertainty
Radiated Emission (9 kHz ~ 30 MHz)	± 1.15 dB
Radiated Emission (30 MHz ~ 200 MHz)	± 1.32 dB
Radiated Emission (200 MHz ~ 1 GHz)	± 1.31 dB
Radiated Emission (1 GHz ~ 18 GHz)	± 1.53 dB
Radiated Emission (18 GHz ~ 40 GHz)	± 2.50 dB
Mains Conducted Emission	± 1.65 dB

Prüfbericht-Nr.: CN242VUR 001
Test report no.:

 Seite 10 von 35
 Page 10 of 35

3. General Product Information

3.1 Product Function and Intended Use

The EUT is a Wireless MCU module with BLE 5.2 compliant and Zigbee 3.0 Radio. It contains a Bluetooth compatible module enabling the user to communicate data through a Wireless interface. For details refer to the User Guide, Data Sheet and Circuit Diagram.

3.2 System Details and Ratings

Basic Information of EUT

Item	EUT information
Kind of Equipment/Test Item	Wireless MCU module with BLE 5.2 compliant and Zigbee 3.0 Radio
Type Identification	WBZ451HPE, WBZ451HUE
FCC ID	2ADHKWBZ451H

Technical Specification of EUT

Item	EUT information
Operating Frequency	2405 MHz ~ 2480 MHz
Channel Spacing	2 MHz
Channel Number	16
Data Rate	1Mbps, 2Mbps, 250kbps, 500kbps
Operation Voltage	1.9Vdc to 3.6Vdc
Modulation	OQPSK
Maximum Output Power (mW)	118.58
Antenna Information	Refer to 5.1.1
Accessory Device	Refer to 4.4

Note:

- All models are listed as below.

Type Identification	Difference
WBZ451HPE	PCB Antenna without Trust and Go Chip
WBZ451HUE	U.FL Antenna without Trust and Go Chip

Prüfbericht-Nr.: CN242VUR 001
Test report no.:

 Seite 11 von 35
 Page 11 of 35

2. Antenna List:

Ant No.	Manufacturer	Part No.	Cable Length (mm)	Antenna Type	Antenna Gain (dBi)	Placement	Remark
1	Pulse	W3525B039	100	PCB	2	External	Applied to model no. WBZ451HUE
2	Laird Connectivity Inc.	001-0016	Flex PIFA antenna	PIFA	2.5	External	
3	LSR	001-0001	RPSMA connector	Dipole	2	External	
4	Molex	1461530100	100 (Dual band)	PCB	3	External	
5	TE Connectivity Linx	ANT-2.4-LPW-125	125	Dipole	2.8	External	
6	Alead	RFA-02-P05-D034	150	PCB	2	External	
7	Alead	RFA-02-P33-D034	150	PCB	2	External	
8	ABRACON	ABAR1504-S2450	250	PCB	2.28	External	
9	Microchip	WBZ451HPA LGA	On-board PCB antenna	PCB	4.08	Internal	Applied to model no. WBZ451HPE

Prüfbericht-Nr.: **CN242VUR 001**
Test report no.:

Seite 12 von 35
Page 12 of 35

3.3 Noise Generating and Noise Suppressing Parts

Refer to the Circuit Diagram.

3.4 Submitted Documents

- Circuit Diagram
- Instruction Manual
- Rating Label
- Technical Description

4. Test Set-up and Operation Modes

4.1 Principle of Configuration Selection

The test modes were adapted accordingly in reference to the instructions for use.

During testing, Channel and Power Controlling Software provided by the customer was used to control the operating channel as well as the output power level. The RF output power selection is for the setting of RF output expected by the customer and is going to be fixed on the firmware of the final end product.

Table for Parameters of Test Software Setting

Power Setting					
Channel	Frequency (MHz)	250kbps	500kbps	1Mbps	2Mbps
11	2405	0	0	0	0
18	2440	0	0	0	0
25	2475	0	0	0	0
26	2480	11	11	11	11

4.2 Carrier Frequency and Channel

Channel	Freq. (MHz)	Channel	Freq. (MHz)
11	2405	19	2445
12	2410	20	2450
13	2415	21	2455
14	2420	22	2460
15	2425	23	2465
16	2430	24	2470
17	2435	25	2475
18	2440	26	2480

Prüfbericht-Nr.: CN242VUR 001
Test report no.:

 Seite 14 von 35
 Page 14 of 35

4.3 Test Operation and Test Software

Setup for testing: Test samples are provided with a USB interface which makes it possible to control them through a test software installed on a notebook computer.

This software was running on the laptop computer connected to the EUT. It was used to enable the operation modes listed as below.

Test Software	MCHPRT3_Setup_v1.0.2.7299
---------------	---------------------------

The samples were used as follows:

Radiated test:

PCB Antenna (Ant No. 9):

A003589924-008 & 009

UFL Antenna (Ant No. 2 & 4 & 5):

A003589924-011, A003119783-009, A003130881-021

Conducted test:

A003589924-010

Full test was applied on all test modes, but only worst case was shown.

EUT Configure Mode	Applicable To				Description
	Antenna Port Conducted Measurement	Radiated Spurious Emissions above 1 GHz	Radiated Spurious Emissions below 1 GHz	Mains Conducted Emission	
Onboard PCB	-	√	√	√	-
uFL	√	√	√	√	-

Note:

1. The EUT had been pre-tested on the positioned of each 3 axis. The worst case was found when position on **Z-plane**.
2. All antennas have been evaluated, with only the worst antennas 2, 4, 5, and the onboard PCB recorded in the report.
3. "-" means no effect.

Antenna Port Conducted Measurement

- Pre-Scan full test was applied on all test modes, but only worst case was shown.
- Following channel(s) was (were) selected for the final test as listed below.

EUT Configure Mode	Available Frequency (MHz)	Tested Frequency (MHz)	Date Rate (Mbps)
uFL	2405 to 2480	2405, 2440, 2480	0.25
	2405 to 2480	2405, 2440, 2480	2

Radiated Spurious Emissions (Above 1 GHz)

- Pre-Scan full test was applied on all test modes, but only worst case was shown.
- Following channel(s) was (were) selected for the final test as listed below.

EUT Configure Mode	Available Frequency (MHz)	Tested Frequency (MHz)	Date Rate (Mbps)
Onboard PCB	2405 to 2480	2405, 2440, 2480	0.25
	2405 to 2480	2405, 2440, 2480	2
uFL	2405 to 2480	2405, 2440, 2480	0.25
	2405 to 2480	2405, 2440, 2480	2

Prüfbericht-Nr.: CN242VUR 001
Test report no.:

 Seite 15 von 35
 Page 15 of 35

Radiated Spurious Emissions (Below 1 GHz)

- Pre-Scan full test was applied on all test modes, but only worst case was shown.
 Following channel(s) was (were) selected for the final test as listed below.

EUT Configure Mode	Available Frequency (MHz)	Tested Frequency (MHz)	Date Rate (Mbps)
Onboard PCB	2405 to 2480	2440	0.25
uFL	2405 to 2480	2480	0.25
	2405 to 2480	2480	2

Mains Conducted Emission

- Pre-Scan full test was applied on all test modes, but only worst case was shown.
 Following channel(s) was (were) selected for the final test as listed below.

EUT Configure Mode	Available Frequency (MHz)	Tested Frequency (MHz)	Date Rate (Mbps)
Onboard PCB	2405 to 2480	2440	0.25
uFL	2405 to 2480	2480	0.25
	2405 to 2480	2480	2

Test Condition

Test Item	Ambient Temperature	Relative Humidity	Tested by
Conducted Measurement	22.5-25.8 °C	55-64 %	Nick Guan
Radiated Spurious Emissions above 1 GHz	23.7-24.6 °C	52-55 %	Ray Huang
Radiated Spurious Emissions below 1 GHz	23.7-24.6 °C	52-55 %	Ray Huang
Mains Conducted Emission	20.1-25.9 °C	50.2-58.9 %	Roger Liao

Prüfbericht-Nr.: CN242VUR 001
Test report no.:

 Seite 16 von 35
 Page 16 of 35

4.4 Special Accessories and Auxiliary Equipment

The product has been tested together with the following additional accessories:

Accessory of EUT

None.

Support Unit

No.	Description	Brand	Model	S/N	Remark
Conducted Test					
-	Notebook	HP	TPN-Q222	5CD2206L9Y	-
PCB Antenna					
Radiated Test					
1	USB to TYPE C	TUV	TUV-01	N/A	180cm non-shielded cable w/o core
2	Notebook	HP	15-da1046TX	CND9111RJB	-
Mains Conducted Test					
1	Adapter	HP	PPP009D	N/A	179cm shielded cable w/o core
2	Notebook	Lenovo	81BL	MP1DCD6Y	-
3	TYPE C to USB	TUV	TUV-01	NO	180cm non-shielded cable w/o core
UFL Antenna					
Radiated Test, Ant No. 2					
A	Antenna PIFA	Mircochip	001-0016	-	10cm A003119783-011
1	USB to TYPE C	TUV	TUV-01	N/A	180cm non-shielded cable w/o core
2	Notebook	HP	15-da1046TX	CND9111RJB	-
Mains Conducted Test, Ant No. 2					
A	Antenna PIFA	Mircochip	001-0016	-	10cm A003119783-011
1	Adapter	HP	PPP009D	N/A	179cm shielded cable w/o core
2	Notebook	Lenovo	81BL	MP1DCD6Y	-
3	TYPE C to USB	TUV	TUV-01	NO	180cm non-shielded cable w/o core
Radiated Test, Ant No. 4					
A	Antenna PCB	Mircochip	1461530100	-	10cm A003119783-009
1	USB to TYPE C	TUV	TUV-01	N/A	180cm non-shielded cable w/o core
2	Notebook	HP	15-da1046TX	CND9111RJB	-
Mains Conducted Test, Ant No. 4					
A	Antenna PCB	Mircochip	1461530100	-	10cm A003119783-009

Prüfbericht-Nr.: CN242VUR 001
Test report no.:

 Seite 17 von 35
 Page 17 of 35

1	Adapter	HP	PPP009D	N/A	179cm shielded cable w/o core
2	Notebook	Lenovo	81BL	MP1DCD6Y	-
3	TYPE C to USB	TUV	TUV-01	NO	180cm non-shielded cable w/o core
Radiated Test, Ant No. 5					
A	Antenna Dipole	Mircochip	2.2-LPW-125	-	20cm A0031300881-021
1	USB to TYPE C	TUV	TUV-01	N/A	180cm non-shielded cable w/o core
2	Notebook	HP	15-da1046TX	CND9111RJB	-
Mains Conducted Test, Ant No. 5					
A	Antenna Dipole	Mircochip	2.2-LPW-125	-	20cm A0031300881-021
1	Adapter	HP	PPP009D	N/A	179cm shielded cable w/o core
2	Notebook	Lenovo	81BL	MP1DCD6Y	-
3	TYPE C to USB	TUV	TUV-01	NO	180cm non-shielded cable w/o core

4.5 Test Setup Diagram

<Radiated Spurious Emissions mode for PCB Antenna>

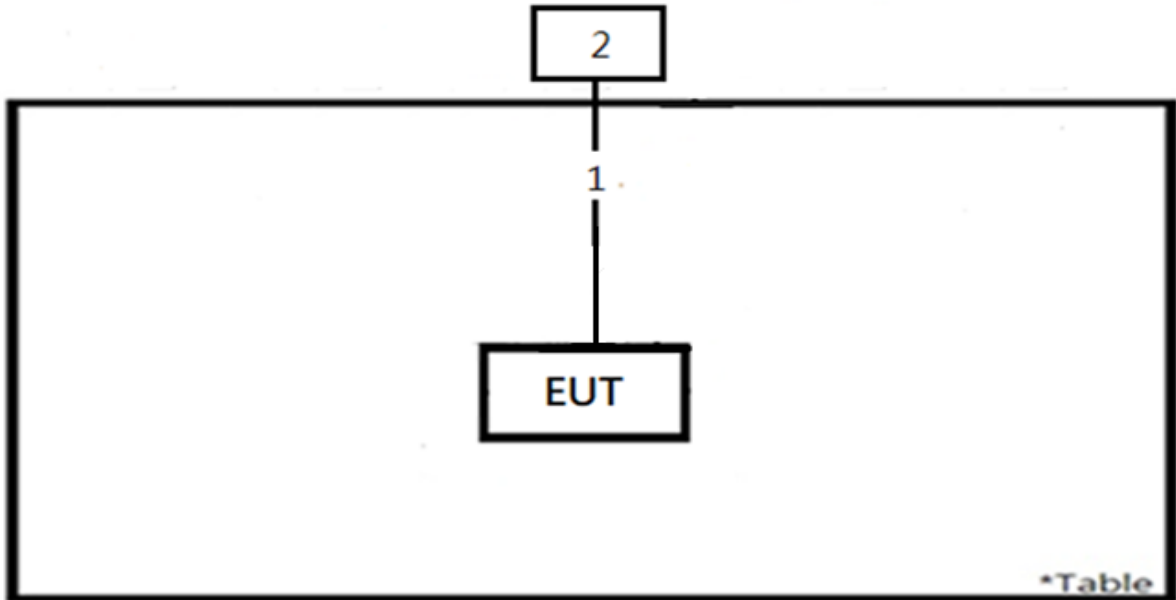

<Mains Conducted Emission mode for PCB Antenna >

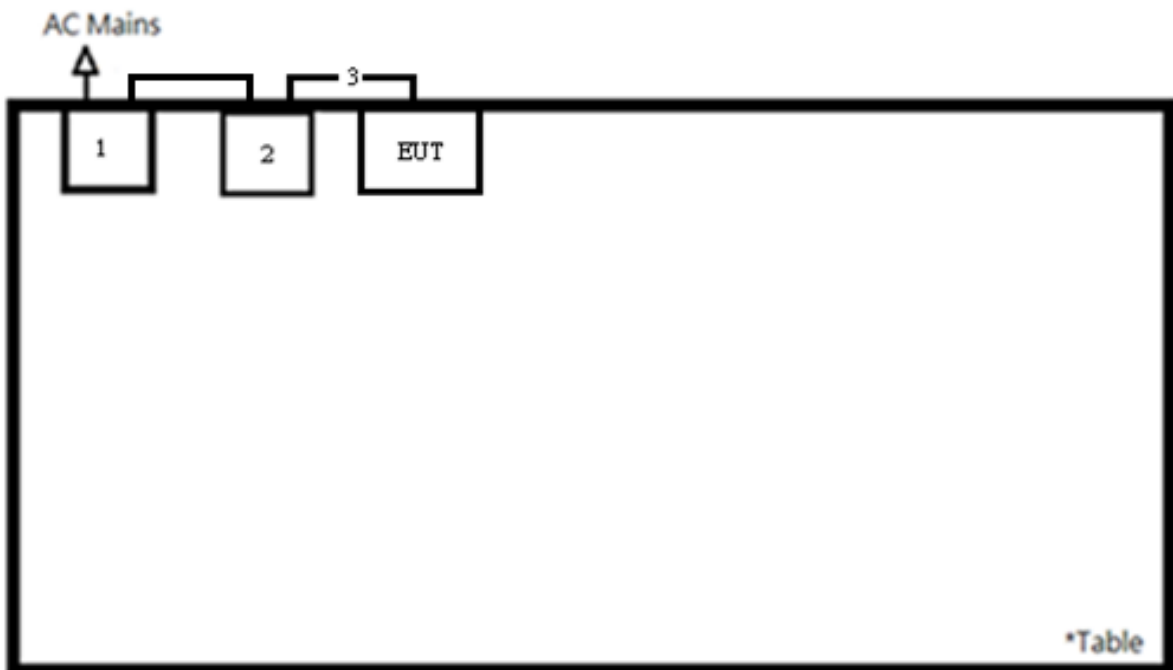

<Radiated Spurious Emissions for UFL Antenna>

Ant No. 2

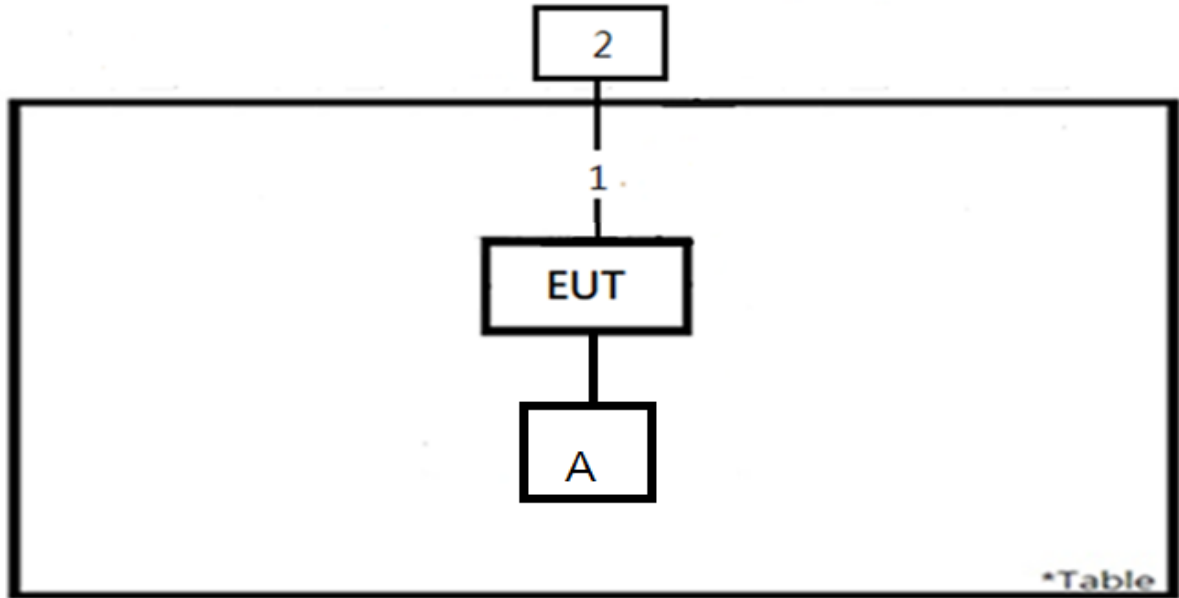

Ant No. 4

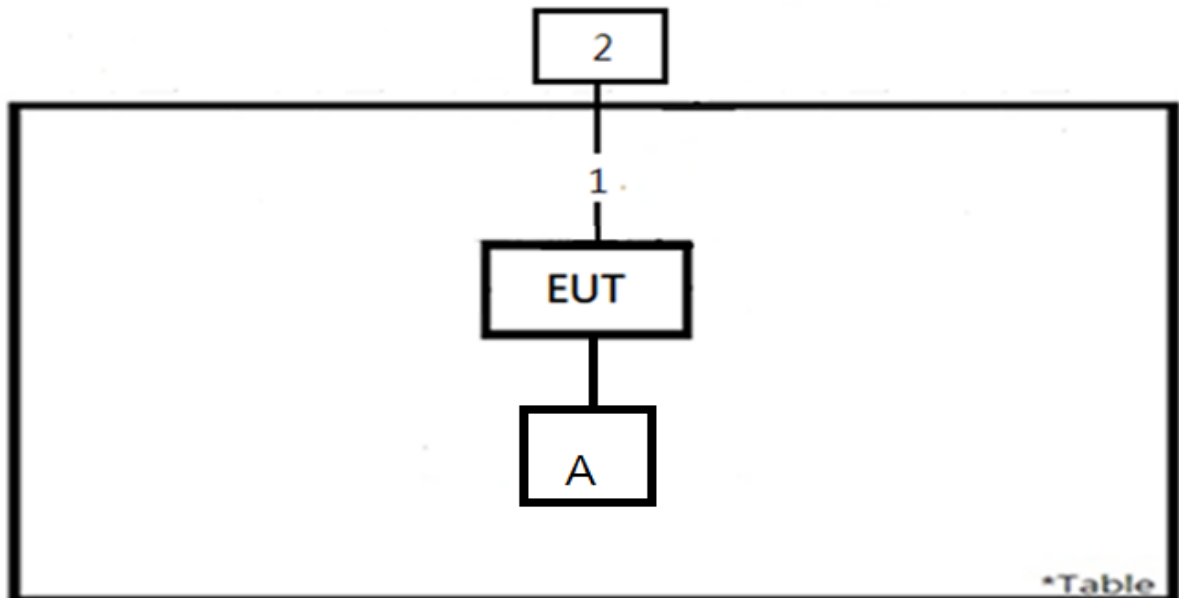

Ant No. 5

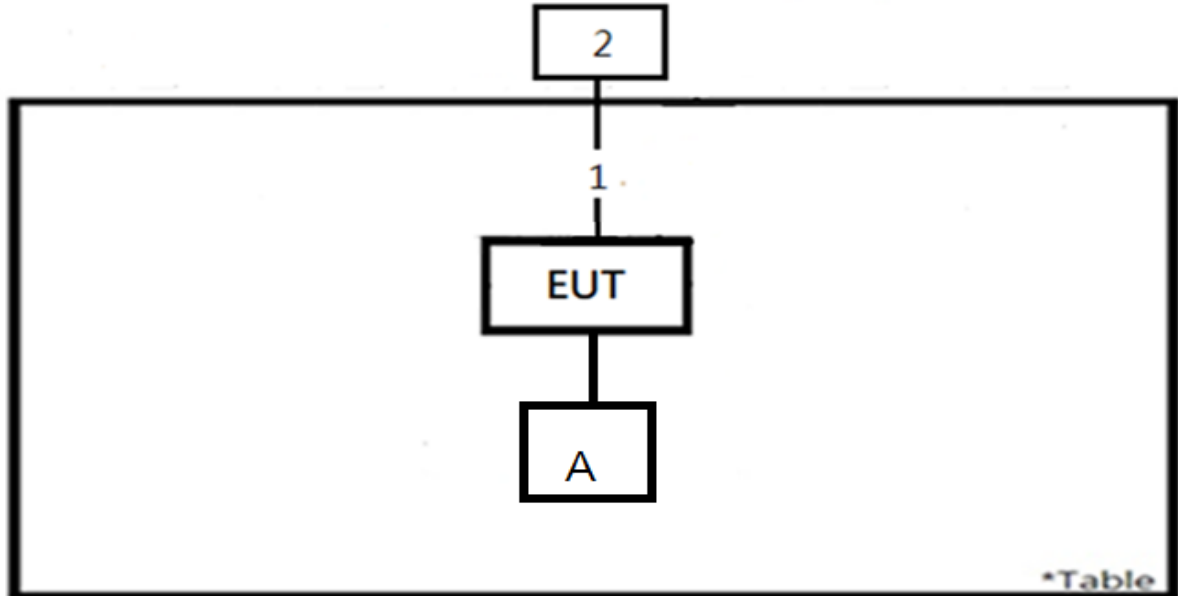

<Mains Conducted Emission mode for UFL Antenna >

Ant No. 2

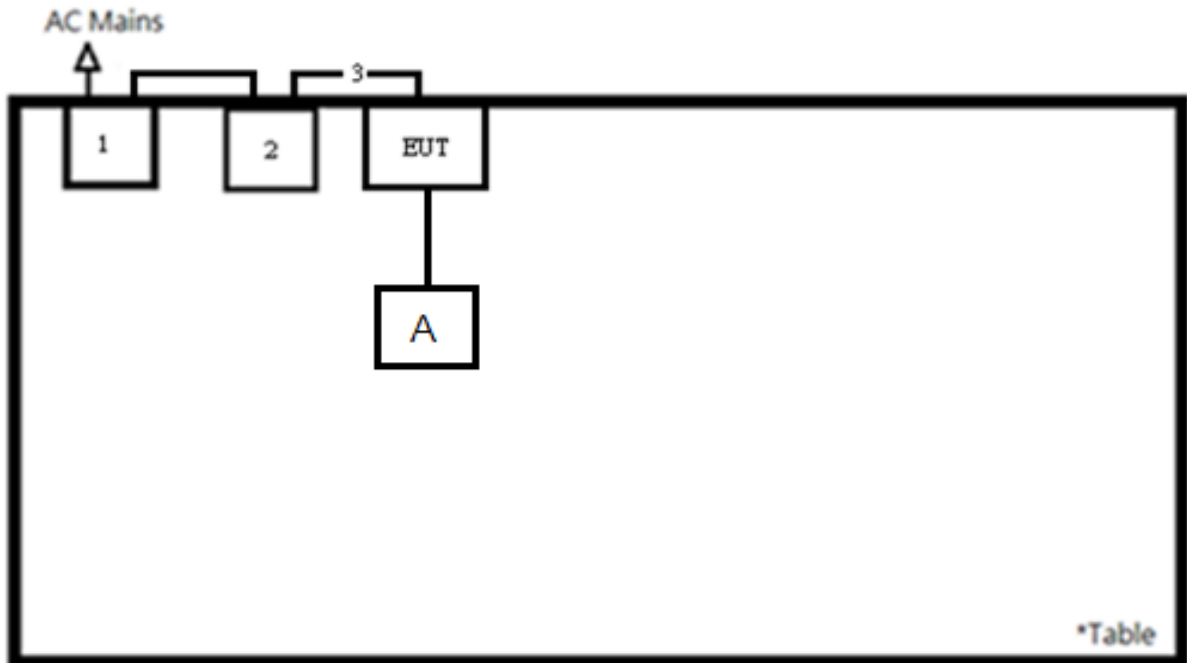

Ant No. 4

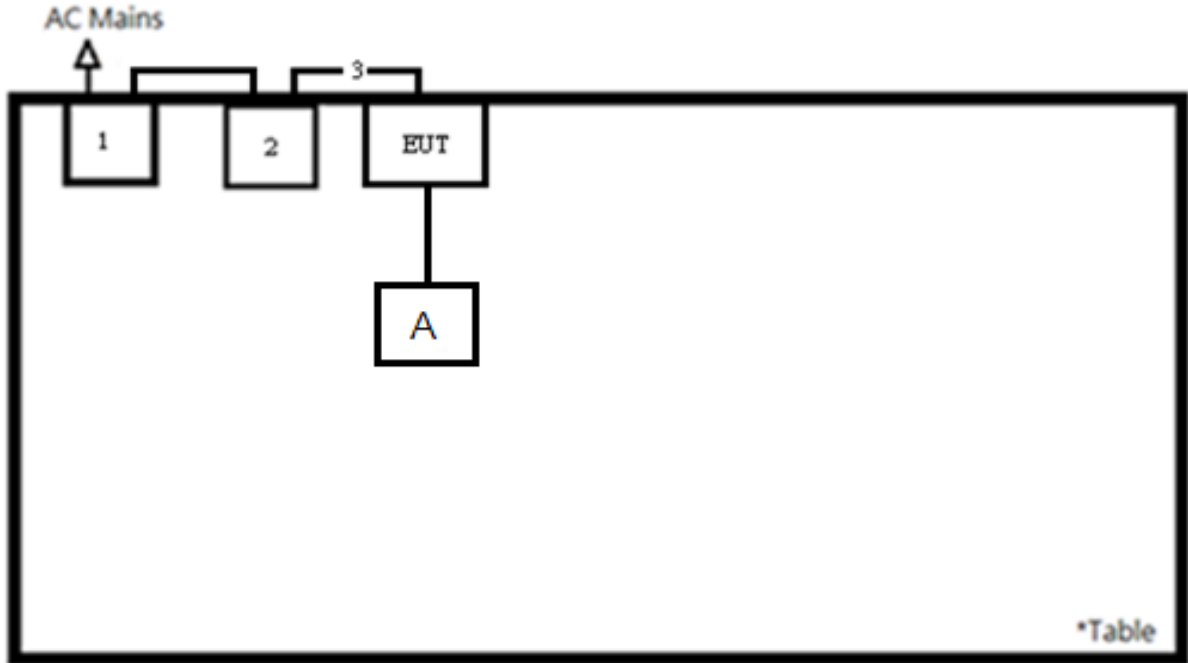

Ant No. 5

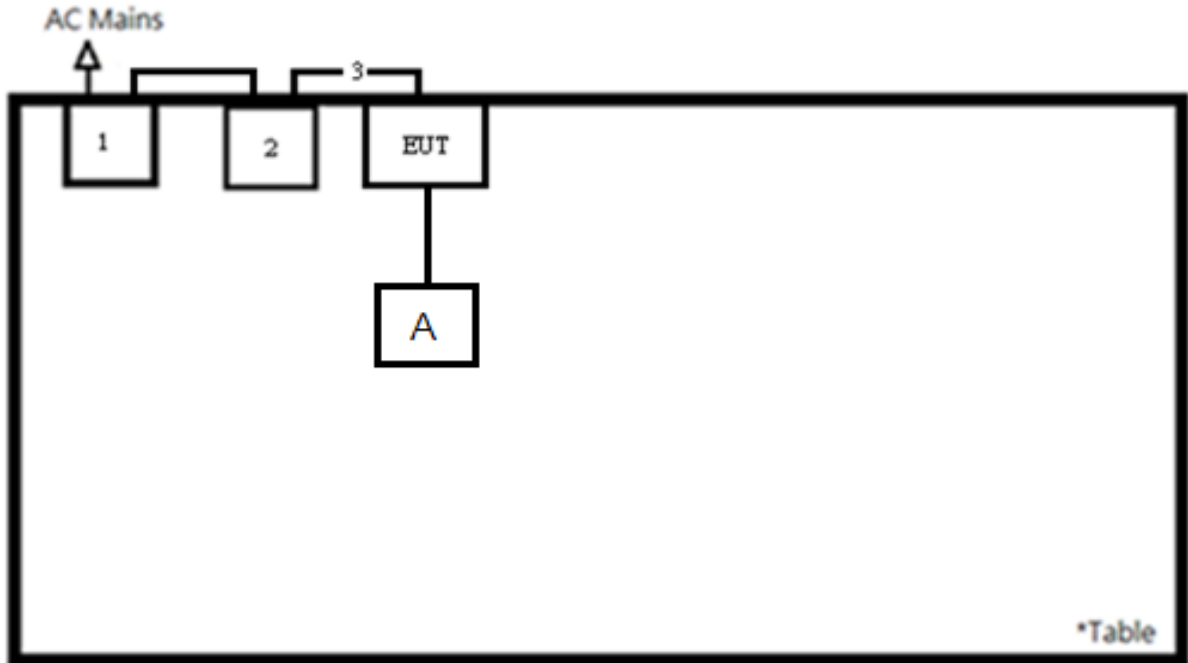

Prüfbericht-Nr.: CN242VUR 001
Test report no.:

 Seite 22 von 35
 Page 22 of 35

5. Test Results

5.1 Transmitter Requirement & Test Suites

5.1.1 Antenna Requirement

Requirement Use of approved antennas only

According to the manufacturer declaration, the antenna information is as listed below.
 The antenna is with no possibility of replacement with a non-approved antenna by the end-user.
 Therefore, the EUT is considered to comply with this provision.

Ant No.	Manufacturer	Part No.	Cable Length (mm)	Antenna Type	Antenna Gain (dBi)	Placement	Remark
1	Pulse	W3525B039	100	PCB	2	External	Applied to model no. WBZ451HUE
2	Laird Connectivity Inc.	001-0016	Flex PIFA antenna	PIFA	2.5	External	
3	LSR	001-0001	RPSMA connector	Dipole	2	External	
4	Molex	1461530100	100 (Dual band)	PCB	3	External	
5	TE Connectivity Linx	ANT-2.4-LPW-125	125	Dipole	2.8	External	
6	Alead	RFA-02-P05-D034	150	PCB	2	External	
7	Alead	RFA-02-P33-D034	150	PCB	2	External	
8	ABRACON	ABAR1504-S2450	250	PCB	2.28	External	
9	Microchip	WBZ451HPA LGA	On-board PCB antenna	PCB	4.08	Internal	Applied to model no. WBZ451HPE

Prüfbericht-Nr.: CN242VUR 001
Test report no.:

 Seite 23 von 35
 Page 23 of 35

5.1.2 Peak Output Power

Limit 1 watt (30 dBm)

Kind of Test Site Shielded room

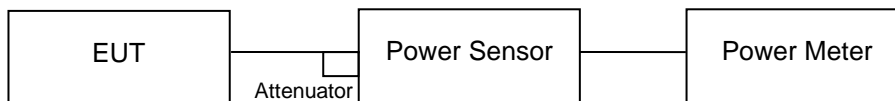
Test Setup

Test Instruments

Kind of Equipment	Manufacturer	Type	S/N	Calibration Date	Calibration Due Date	Test Date	
						From	Until
Power Meter	Anritsu	ML2495A	1901008	2023/03/17	2024/03/16	2023/12/08	2024/02/01
Power Sensor	Anritsu	MA2411B	1725269	2023/03/17	2024/03/16	2023/12/08	2024/02/01

Test Procedures

A peak power sensor was used on the output port of the EUT. A power meter was used to read the response of the peak power sensor. Record the power level.

Average power sensor was used to perform output power measurement, trigger and gating function of wide band power meter is enabled to measure max output power of TX on burst. Duty factor is not added to measured value.

Prüfbericht-Nr.: CN242VUR 001
Test report no.:
Test Result
Peak Output Power
<250kbps, by UFL Antenna Ant No. 2>

Channel	Channel Frequency	Peak Output Power		Limit (dBm)
	(MHz)	(dBm)	(mW)	
11	2405	20.08	101.86	30
18	2440	20.74	118.58	30
25	2475	20.49	111.94	30
26	2480	7.27	5.33	30

<500kbps, by UFL Antenna Ant No. 2>

Channel	Channel Frequency	Peak Output Power		Limit (dBm)
	(MHz)	(dBm)	(mW)	
11	2405	20.03	100.69	30
18	2440	20.69	117.22	30
25	2475	20.45	110.92	30
26	2480	7.23	5.28	30

<1Mbps, by UFL Antenna Ant No. 2>

Channel	Channel Frequency	Peak Output Power		Limit (dBm)
	(MHz)	(dBm)	(mW)	
11	2405	20.04	100.93	30
18	2440	20.71	117.76	30
25	2475	20.46	111.17	30
26	2480	7.24	5.30	30

<2Mbps, by UFL Antenna Ant No. 2>

Channel	Channel Frequency	Peak Output Power		Limit (dBm)
	(MHz)	(dBm)	(mW)	
11	2405	20.06	101.39	30
18	2440	20.73	118.30	30
25	2475	20.48	111.69	30
26	2480	7.26	5.32	30

Prüfbericht-Nr.: CN242VUR 001
Test report no.:

 Seite 25 von 35
 Page 25 of 35

Average Power
<250kbps, by UFL Antenna Ant No. 2>

Channel	Channel Frequency	Average Power	
	(MHz)	(dBm)	(mW)
11	2405	19.02	79.80
18	2440	19.91	97.95
25	2475	19.68	92.90
26	2480	6.24	4.21

<500kbps, by UFL Antenna Ant No. 2>

Channel	Channel Frequency	Average Power	
	(MHz)	(dBm)	(mW)
11	2405	18.97	78.89
18	2440	19.86	96.83
25	2475	19.63	91.83
26	2480	6.20	4.17

<1Mbps, by UFL Antenna Ant No. 2>

Channel	Channel Frequency	Average Power	
	(MHz)	(dBm)	(mW)
11	2405	18.99	79.25
18	2440	19.87	97.05
25	2475	19.65	92.26
26	2480	6.22	4.19

<2Mbps, by UFL Antenna Ant No. 2>

Channel	Channel Frequency	Average Power	
	(MHz)	(dBm)	(mW)
11	2405	19.00	79.43
18	2440	19.90	97.72
25	2475	19.66	92.47
26	2480	6.23	4.20

Prüfbericht-Nr.: CN242VUR 001
Test report no.:

 Seite 26 von 35
 Page 26 of 35

5.1.3 6 dB Bandwidth and 99% Occupied Bandwidth

Limit The minimum 6 dB bandwidth shall be at least 500 kHz.

Kind of Test Site Shielded room

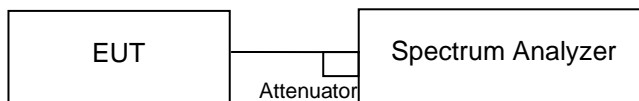
Test Setup

Test Instruments

Kind of Equipment	Manufacturer	Type	S/N	Calibration Date	Calibration Due Date	Test Date	
						From	Until
Spectrum Analyzer	R&S	FSV	101512	2023/02/23	2024/02/22	2023/12/08	2024/02/01

Test Procedure

- a. Set resolution bandwidth (RBW) = 100 kHz
- b. Set the video bandwidth (VBW) $\geq 3 \times$ RBW, Detector = Peak.
- c. Trace mode = max hold.
- d. Sweep = auto couple.
- e. Measure the maximum width of the emission that is constrained by the frequencies associated with the two amplitude points (upper and lower) that are attenuated by 6 dB relative to the maximum level measured in the fundamental emission.
- f. For 99% occupied bandwidth measurement, the transmitter output was connected to the spectrum analyzer through an attenuator. The bandwidth of the fundamental frequency was measured by spectrum analyzer with resolution bandwidth in the range of 1% to 5% of the anticipated emission bandwidth, and a video bandwidth at least 3x the resolution bandwidth and set the detector to PEAK. The width of a frequency band such that, below the lower and above the upper frequency limits, the mean powers emitted are each equal to a specified percentage 0.5% of the total mean power of a given emission.

Test Results

Please refer to Appendix A.

Prüfbericht-Nr.: CN242VUR 001
Test report no.:

 Seite 27 von 35
 Page 27 of 35

5.1.4 Power Spectral Density

Limit

The power spectral density shall not be greater than 8 dBm in any 3 kHz band.

Kind of Test Site Shielded room

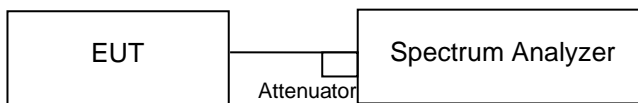
Test Setup

Test Instruments

Kind of Equipment	Manufacturer	Type	S/N	Calibration Date	Calibration Due Date	Test Date	
						From	Until
Spectrum Analyzer	R&S	FSV	101512	2023/02/23	2024/02/22	2023/12/08	2024/02/01

Test Procedure

- a. Set analyzer center frequency to DTS channel center frequency.
- b. Set the span to 1.5 times the DTS bandwidth.
- c. Set the RBW to: $3 \text{ kHz} \leq \text{RBW} \leq 100 \text{ kHz}$.
- d. Set the VBW $\geq 3 \times \text{RBW}$.
- e. Detector = peak.
- f. Sweep time = auto couple.
- g. Trace mode = max hold.
- h. Allow trace to fully stabilize.
- i. Use the peak marker function to determine the maximum amplitude level within the RBW.

Test Results

Please refer to Appendix A.

Prüfbericht-Nr.: CN242VUR 001
Test report no.:

 Seite 28 von 35
 Page 28 of 35

5.1.5 Conducted Spurious Emissions and Frequency Band Edges Measured in 100kHz Bandwidth

Limit

20dB (below that in the 100 kHz bandwidth within the band that contains the highest level of the desired power.)

Kind of Test Site Shielded room

Test Setup

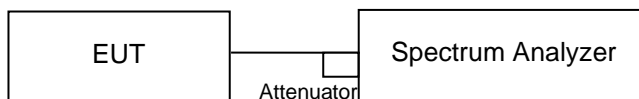

Test Instruments

Kind of Equipment	Manufacturer	Type	S/N	Calibration Date	Calibration Due Date	Test Date	
						From	Until
Spectrum Analyzer	R&S	FSV	101512	2023/02/23	2024/02/22	2023/12/08	2024/02/01

Test Procedure

Measurement procedure REF

1. Set the RBW = 100 kHz.
2. Set the VBW \geq 300 kHz.
3. Detector = peak.
4. Sweep time = auto couple.
5. Trace mode = max hold.
6. Allow trace to fully stabilize.
7. Use the peak marker function to determine the maximum power level in any 100 kHz band segment within the fundamental EBW.

Measurement procedure OOBE

1. Set RBW = 100 kHz.
2. Set VBW \geq 300 kHz.
3. Detector = peak.
4. Sweep = auto couple.
5. Trace Mode = max hold.
6. Allow trace to fully stabilize.
7. Use the peak marker function to determine the maximum amplitude level.

Test Results

Please refer to Appendix A.

5.1.6 Radiated Spurious Emissions and Band Edges

Limit

Radiated emissions which fall in the restricted bands, as defined in §15.205(a), must comply with the radiated emission limits specified in §15.209(a).

Emissions radiated outside the restricted and authorized frequency bands must either comply with the radiated emission limits specified for the restricted bands or in §15.247(d).

Kind of Test Site 3m Semi-Anechoic Chamber

Test Setup

<Radiated Emissions below 30 MHz>

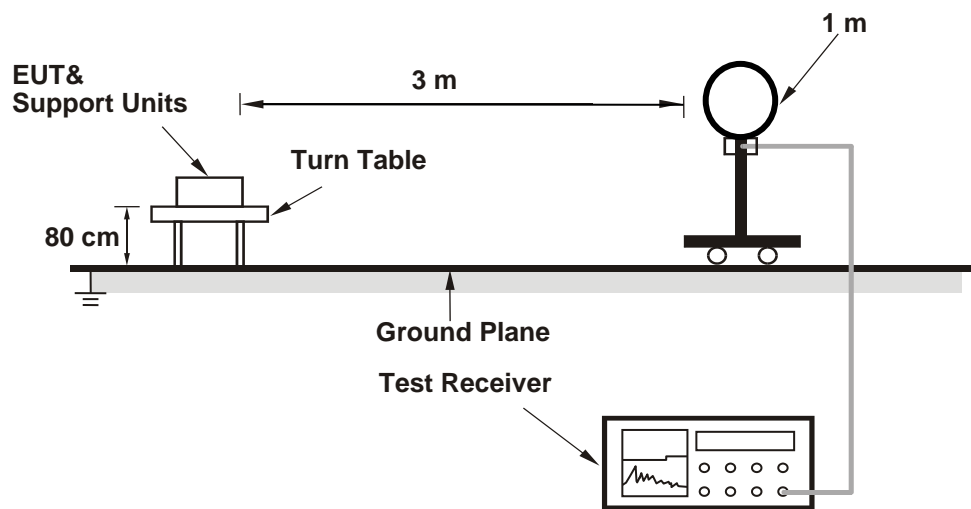

<Radiated Emissions 30 MHz to 1 GHz>

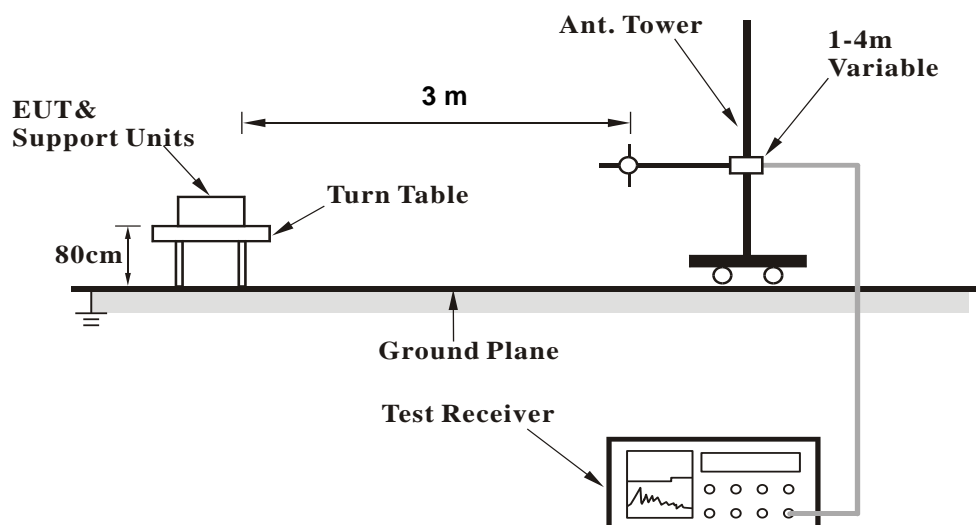

<Radiated Emissions above 1 GHz>

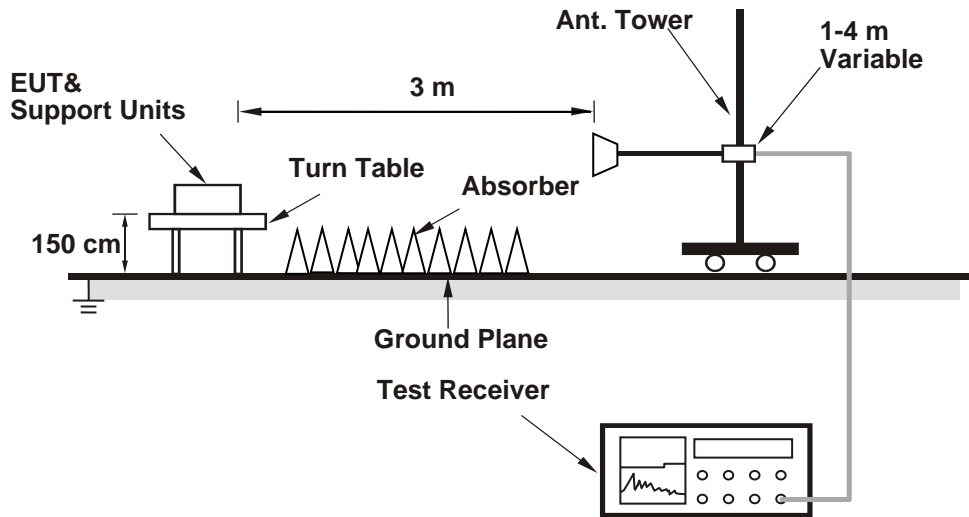

For the actual test configuration, please refer to the attached file (Test Setup Photo).

Prüfbericht-Nr.: CN242VUR 001
Test report no.:
Test Instruments

Kind of Equipment	Manufacturer	Type	S/N	Calibration Date	Calibration Due Date
Above 1GHz					
Signal Analyzer	R&S	FSV40	101509	2023/4/26	2024/4/24
Horn Antenna	ETS-Lindgren	3117	00218929	2023/11/17	2024/11/15
Horn Antenna	SCHWARZBECK	BBHA 9170	00890	2023/5/4	2024/5/2
HF-AMP + AC source	EMCI	EMC051845SE	980635	2023/2/16	2024/2/15
HF-AMP + AC source	EMCI	EMC051845SE	980633	2024/1/24	2025/1/22
HF-AMP + AC source	EMCI	EMC051845SE	980657	2023/2/16	2024/2/15
HF-AMP + AC source	EMCI	EMC051845SE	980656	2024/1/18	2025/1/16
30MHz-1GHz					
Receiver	R&S	ESR7	102109	2023/2/24	2024/2/23
Bilog Antenna	SCHWARZBECK	VULB-9168	00951	2023/3/31	2024/3/29
LF-AMP	Agilent	8447D	2944A107722	2023/3/22	2024/3/20
Below 30MHz					
Receiver	R&S	ESR7	102109	2023/2/24	2024/2/23
Loop Antenna	SCHWARZBECK	FMZB 1519B	00215	2023/1/4	2024/1/3
Loop Antenna	SCHWARZBECK	FMZB 1519B	00215	2024/1/4	2025/1/2

Prüfbericht-Nr.: **CN242VUR 001**
Test report no.:Seite 32 von 35
Page 32 of 35**Test Procedures****For Radiated Emissions below 30 MHz**

- a. The EUT was placed on the top of a rotating table 0.8 meters above the ground at a 3 meter chamber room. The table was rotated 360 degrees to determine the position of the highest radiation.
- b. The EUT was set 3 meters away from the interference-receiving antenna, which was mounted on the top of a variable-height antenna tower.
- c. Parallel (OPEN), perpendicular (CLOSE), and ground-parallel (GROUND) orientations of the antenna are set to make the measurement.
- d. For each suspected emission, the EUT was arranged to its worst case and the rotatable table was turned from 0 degrees to 360 degrees to find the maximum reading.
- e. The test-receiver system was set to Quasi-Peak Detect Function and Specified Bandwidth with Maximum Hold Mode.

Note:

1. The resolution bandwidth and video bandwidth of test receiver/spectrum analyzer is 9 kHz at frequency below 30 MHz.
2. All modes of operation were investigated and the worst-case emissions are reported.

For Radiated Emissions above 30 MHz

- a. The EUT was placed on the top of a rotating table 0.8 meters (for 30 MHz ~ 1 GHz) / 1.5 meters (for above 1 GHz) above the ground at 3 meter chamber room for test. The table was rotated 360 degrees to determine the position of the highest radiation.
- b. The EUT was set 3 meters away from the interference-receiving antenna, which was mounted on the top of a variable-height antenna tower.
- c. The height of antenna is varied from one meter to four meters above the ground to determine the maximum value of the field strength. Both horizontal and vertical polarizations of the antenna are set to make the measurement.
- d. For each suspected emission, the EUT was arranged to its worst case and then the antenna was tuned to heights from 1 meter to 4 meters and the rotatable table was turned from 0 degrees to 360 degrees to find the maximum reading.
- e. The test-receiver system was set to quasi-peak detect function and specified bandwidth with maximum hold mode when the test frequency is below 1 GHz.
- f. The test-receiver system was set to peak and average detected function and specified bandwidth with maximum hold mode when the test frequency is above 1 GHz. If the peak reading value also meets average limit, measurement with the average detector is unnecessary.

Note:

1. The resolution bandwidth and video bandwidth of test receiver/spectrum analyzer is 120 kHz for Quasi-peak detection (QP) or Peak detection (PK) at frequency below 1 GHz.
2. The resolution bandwidth of test receiver/spectrum analyzer is 1 MHz and the video bandwidth is 3 MHz for Peak detection (PK) at frequency above 1 GHz.
3. The resolution bandwidth of test receiver/spectrum analyzer is 1 MHz and the video bandwidth is $\geq 1/T$ (Duty cycle < 98 %) or 10 Hz (Duty cycle ≥ 98 %) for Average detection (AV) at frequency above 1 GHz.
4. All modes of operation were investigated and the worst-case emissions are reported.
5. The Radiated Emissions testing was performed in the X(E1), Y(E2) and Z(E3) axis orientation. The worst-case Axis orientation is recorded in this test report.
6. The emission levels of other frequencies (including the 10th harmonic of the highest fundamental frequency) are very lower than the limit and are not shown in the test report.

Prüfbericht-Nr.: **CN242VUR 001**
Test report no.:

Seite 33 von 35
Page 33 of 35

Test Results

Factor (dB/m) = Antenna Factor (dB/m) + Cable Loss (dB)

Level (dBuV/m) = Reading (dBuV) + Factor (dB/m)

Please refer to Appendix B for PCB antenna and Appendix C for UFL antennas.

Prüfbericht-Nr.: CN242VUR 001
Test report no.:

 Seite 34 von 35
 Page 34 of 35

5.2 Mains Emission

5.2.1 Mains Conducted Emission

Limit

Mains Conducted Emission as defined in §15.207 must comply with the mains conducted emission limits.

Kind of Test Site Shielded room

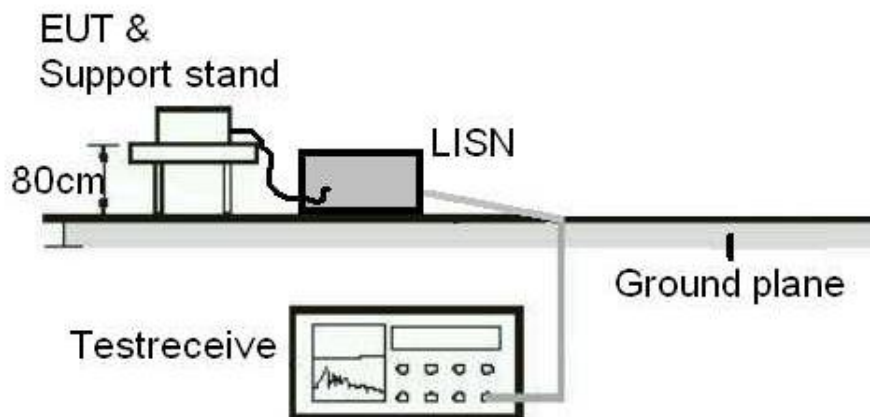
Test Setup

Test Instruments

Kind of Equipment	Manufacturer	Type	S/N	Calibration Date	Calibration Due Date
Two-Line V-Network	Rohde & Schwarz	ENV216	101938	2023/10/23	2024/10/21
EMI Test Receiver	R&S	ESCI	100797	2023/7/21	2024/7/19

Prüfbericht-Nr.: **CN242VUR 001**
Test report no.:

Seite 35 von 35
Page 35 of 35

Test Procedures

- a. The EUT was placed 0.4 meters from the conducting wall of the shielded room with EUT being connected to the power mains through a line impedance stabilization network (LISN). Other support units were connected to the power mains through another LISN. The two LISNs provide 50 ohm/50 uH of coupling impedance for the measuring instrument.
- b. Both lines of the power mains connected to the EUT were checked for maximum conducted interference.
- c. The frequency range from 150 kHz to 30 MHz was searched. Emission levels under (Limit – 20 dB) was not recorded.

Note: The resolution bandwidth and video bandwidth of test receiver is 9 kHz for quasi-peak detection (QP) and average detection (AV) at frequency 0.15 MHz – 30 MHz.

Test Results

Please refer to Appendix B for PCB antenna and Appendix C for UFL antennas.