

Prüfbericht-Nr.: <i>Test report no.:</i>	CN23I8SK (P15C-ZigBee) 001	Auftrags-Nr.: <i>Order no.:</i>	48219811	Seite 1 von 36 Page 1 of 36
Kunden-Referenz-Nr.: <i>Client reference no.:</i>	N/A	Auftragsdatum: <i>Order date:</i>	2023-06-01	
Auftraggeber: <i>Client:</i>	Microchip Technology Inc. 2355 West Chandler Blvd. Chandler, Arizona 85224-6199, United States			
Prüfgegenstand: <i>Test item:</i>	Wireless MCU module with BLE 5.2 compliant and Zigbee 3.0 Radio			
Bezeichnung / Typ-Nr.: <i>Identification / Type no.:</i>	WBZ350PE,WBZ350UE,WBZ350PC,WBZ350UC,RNBD350PE,RNBD350UE,RNBD350PC,RNBD350UC			
Auftrags-Inhalt: <i>Order content:</i>	FCC Part 15C Test report (ZigBee)			
Prüfgrundlage: <i>Test specification:</i>	FCC 47CFR Part 15: Subpart C Section 15.247			
Wareneingangsdatum: <i>Date of sample receipt:</i>	2023-07-10 2023-08-30			
Prüfmuster-Nr.: <i>Test sample no.:</i>	A003513812-001, 002, A003513812-008, 009, A003513812-010, 011			
Prüfzeitraum: <i>Testing period:</i>	2023-07-15 - 2023-08-16, 2023-10-06			
Ort der Prüfung: <i>Place of testing:</i>	EMC/RF Taipei Testing Site			
Prüflaboratorium: <i>Testing laboratory:</i>	Taipei Testing Laboratories			
Prüfergebnis*: <i>Test result*:</i>	Pass			
zusammengestellt von: <i>compiled by:</i>	 Ryan Chen			
Datum: <i>Date:</i>	2023-10-12	Ausstellungsdatum: <i>Issue date:</i>	2023-10-12	
Stellung / Position:	Senior Project Manager	Stellung / Position:	Senior Project Manager	
Sonstiges / Other:	The 2nd source (16MHz Crystal, RF frontend and antenna matching) has been evaluated in this report, and the parameter of component is the same as the original one. The difference is the manufacturer.			
Zustand des Prüfgegenstandes bei Anlieferung: <i>Condition of the test item at delivery:</i>	Prüfmuster vollständig und unbeschädigt <i>Test item complete and undamaged</i>			
* Legende:	1 = sehr gut P(ass) = entspricht o.g. Prüfgrundlage(n)	2 = gut F(ail) = entspricht nicht o.g. Prüfgrundlage(n)	3 = befriedigend F(ail) = entspricht nicht o.g. Prüfgrundlage(n)	4 = ausreichend N/A = nicht anwendbar
* Legend:	1 = very good P(ass) = passed a.m. test specification(s)	2 = good F(ail) = failed a.m. test specification(s)	3 = satisfactory F(ail) = failed a.m. test specification(s)	4 = sufficient N/A = not applicable
<p>Dieser Prüfbericht bezieht sich nur auf das o.g. Prüfmuster und darf ohne Genehmigung der Prüfstelle nicht auszugsweise vervielfältigt werden. Dieser Bericht berechtigt nicht zur Verwendung eines Prüfzeichens. <i>This test report only relates to the a. m. test sample. Without permission of the test center this test report is not permitted to be duplicated in extracts. This test report does not entitle to carry any test mark.</i></p>				

v05

TEST SUMMARY

Report Section	FCC Clause	Test Item	Result
5.1.1	15.247(b) & 15.203	Antenna Requirement	Pass
5.1.2	15.247(b)(3)	Peak Output Power	Pass
5.1.3	15.247(a)(2)	6 dB Bandwidth	Pass
5.1.3	2.1049	99% Occupied Bandwidth	Pass
5.1.4	15.247(e)	Power Spectral Density	Pass
5.1.5	15.247(d)	Conducted Spurious Emissions and Band Edges	Pass
5.1.6	15.247(d) & 15.205 & 15.209	Radiated Spurious Emissions and Band Edges	Pass
5.2.1	15.207	Mains Conducted Emission	Pass

Note: Determining compliance based on the results of the compliance measurement, not taking into account measurement instrumentation uncertainty.

Contents

HISTORY OF THIS TEST REPORT	5
1. GENERAL REMARKS	6
1.1 COMPLEMENTARY MATERIALS.....	6
1.2 DECISION RULE OF CONFORMITY	6
2. TEST SITES	7
2.1 TEST LABORATORY	7
2.2 TEST FACILITY.....	7
2.3 TRACEABILITY	8
2.4 CALIBRATION	8
2.5 MEASUREMENT UNCERTAINTY	8
3. GENERAL PRODUCT INFORMATION.....	9
3.1 PRODUCT FUNCTION AND INTENDED USE	9
3.2 SYSTEM DETAILS AND RATINGS.....	9
3.3 NOISE GENERATING AND NOISE SUPPRESSING PARTS	11
3.4 SUBMITTED DOCUMENTS.....	11
4. TEST SET-UP AN OPERATION MODES	12
4.1 PRINCIPLE OF CONFIGURATION SELECTION	12
4.2 CARRIER FREQUENCY AND CHANNEL.....	12
4.3 TEST OPERATION AND TEST SOFTWARE.....	13
4.4 SPECIAL ACCESSORIES AND AUXILIARY EQUIPMENT	15
4.5 TEST SETUP DIAGRAM	17
5. TEST RESULTS	21
5.1 TRANSMITTER REQUIREMENT & TEST SUITES	21
5.1.1 <i>Antenna Requirement</i>	<i>21</i>
5.1.2 <i>Peak Output Power</i>	<i>22</i>
5.1.3 <i>6 dB Bandwidth and 99% Occupied Bandwidth.....</i>	<i>27</i>
5.1.4 <i>Power Spectral Density.....</i>	<i>28</i>
5.1.5 <i>Conducted Spurious Emissions and Frequency Band Edges Measured in 100kHz Bandwidth</i>	<i>29</i>
5.1.6 <i>Radiated Spurious Emissions and Band Edges</i>	<i>30</i>
5.2 MAINS EMISSION	35
5.2.1 <i>Mains Conducted Emission.....</i>	<i>35</i>

Prüfbericht - Nr.: CN23I8SK (P15C-ZigBee) 001
Test Report No.

Seite 4 von 36
Page 4 of 36

Appendix A - Test Result of Conducted

**Appendix B - Test Result of Radiated Emissions & Mains Conducted Emission
for PCB Antenna**

**Appendix C- Test Result of Radiated Emissions & Mains Conducted Emission
for UFL Antenna**

**Appendix D- Test Result of Radiated Emissions & Mains Conducted Emission
for PIFA Antenna**

Appendix SP - Photographs of Test Setup

Appendix EP - Photographs of EUT

HISTORY OF THIS TEST REPORT

Report No.	Description	Date Issued
CN23I8SK (P15C-ZigBee) 001	Original Release	2023-10-12

1. General Remarks

1.1 Complementary Materials

All attachments are integral parts of this test report. This applies especially to the following appendix:

Appendix A - Test Result of Conducted

Appendix B - Test Result of Radiated Emissions & Mains Conducted Emission for PCB Antenna

Appendix C- Test Result of Radiated Emissions & Mains Conducted Emission for UFL Antenna

Appendix D- Test Result of Radiated Emissions & Mains Conducted Emission for PIFA Antenna

Appendix SP - Photographs of Test Setup

Appendix EP - Photographs of EUT

Applied Standard and Test Levels

Radio
FCC 47CFR Part 15: Subpart C Section 15.247
FCC 47CFR Part 2: Subpart J Section 2.1049
ANSI C63.10:2013
KDB 558074 D01 15.247 Meas Guidance v05r02

1.2 Decision Rule of Conformity

The decision rule of conformity of this test report is following the requirements of the requested standard in the quotation, and agreed among testing laboratory and manufacturer (applicant) to exclude the consideration of Measurement Uncertainty, unless it is required by the specific standard.

2. Test Sites

2.1 Test Laboratory

Taipei Testing Laboratories

11F. No.758, Sec. 4, Bade Rd., Songshan Dist.
Taipei City 105
Taiwan (R.O.C.)

2.2 Test Facility

Taipei Testing Laboratories

No.458-18, Sec. 2, Fenliao Rd., Linkou Dist.,
New Taipei City 244
Taiwan (R.O.C.)
FCC Registration No.: 180491
ISED Registration No.: 25563

2.3 Traceability

All measurement equipment calibrations are traceable to NML(Taiwan)/NIST(USA) or where calibration is performed outside Taiwan, to equivalent nationally recognized standards organizations.

2.4 Calibration

Equipment requiring calibration is calibrated periodically in a suitably accredited Calibration Lab. Additionally all equipment is verified for proper performance on a regular basis using in house standards or comparisons.

2.5 Measurement Uncertainty

All measurement uncertainty values are shown with a coverage factor of $k=2$ to indicate a 95% level of confidence.

Emission Measurement Uncertainty

Parameter	Uncertainty
Radiated Emission (9 kHz ~ 30 MHz)	± 1.15 dB
Radiated Emission (30 MHz ~ 200 MHz)	± 1.32 dB
Radiated Emission (200 MHz ~ 1 GHz)	± 1.31 dB
Radiated Emission (1 GHz ~ 18 GHz)	± 1.53 dB
Radiated Emission (18 GHz ~ 40 GHz)	± 2.50 dB
Mains Conducted Emission	± 1.65 dB

3. General Product Information

3.1 Product Function and Intended Use

The EUT is a Wireless MCU module with BLE 5.2 compliant and Zigbee 3.0 Radio. It contains a ZigBee compatible module enabling the user to communicate data through a Wireless interface.

For details refer to the User Guide, Data Sheet and Circuit Diagram.

3.2 System Details and Ratings

Basic Information of EUT

Item	EUT information
Kind of Equipment/Test Item	Wireless MCU module with BLE 5.2 compliant and Zigbee 3.0 Radio
Type Identification	WBZ350PE, WBZ350UE, WBZ350PC, WBZ350UC, RNBD350PE, RNBD350UE, RNBD350PC, RNBD350UC
FCC ID	2ADHKWBZ350

Technical Specification of EUT

Item	EUT information
Operating Frequency	2405 MHz ~ 2480 MHz
Channel Spacing	5 MHz
Channel Number	16
Data Rate	1Mbps, 2Mbps, 250kbps, 500kbps
Operation Voltage	Non ECC variants: 1.9Vdc to 3.6Vdc ECC variant : 2Vdc to 3.6Vdc
Modulation	OQPSK
Maximum Output Power (mW)	14.62
Antenna Information	Refer to 5.1.1
Accessory Device	Refer to 4.4

Note:

- All models are listed as below.

Type Identification	Difference
WBZ350PE	PCB antenna without Trust and Go Chip
WBZ350UE	u.FL antenna without Trust and Go Chip
WBZ350PC	PCB antenna with Trust and Go Chip
WBZ350UC	u.FL antenna with Trust and Go Chip
RNBD350PE	same as WBZ350PE with different application software
RNBD350UE	same as WBZ350UE with different application software
RNBD350PC	same as WBZ350PC with different application software
RNBD350UC	same as WBZ350UC with different application software

2. Antenna List:

ANT No.	Brand Name	SN/Model #	Cable Length (mm)	Type	Gain (dBi)	Placement	Remark
1	Pulse	W3525B039	100	PCB	2	External	Applied to model no. WBZ350UE and WBZ350UC
2	PSA	RFDPA870915IMAB306	150	Dipole	1.82	External	
3	Laird	001-0016	100	PIFA	2.5	External	
4	LSR	001-0001	RPSMA connector	Dipole	2	External	
5	Molex	1461530100	100 (Dual Band)	PCB	3	External	
6	Linx	ANT-2.4-LPW-125	125	Dipole	2.8	External	
7	ALEAD	RFA-02-P05-D034	150	PCB	2	External	
8	ALEAD	RFA-02-P33-D034	150	PCB	2	External	
9	ABRACON	ABAR1504-S2450	250	PCB	2.28	External	
10	Microchip	WBZ350	-	PCB	2.9	Internal	Applied to model no. WBZ350PE and WBZ350PC

3.3 Noise Generating and Noise Suppressing Parts

Refer to the Circuit Diagram.

3.4 Submitted Documents

- Circuit Diagram
- Instruction Manual
- Rating Label
- Technical Description

4. Test Set-up an Operation Modes

4.1 Principle of Configuration Selection

The test modes were adapted accordingly in reference to the instructions for use.

During testing, Channel and Power Controlling Software provided by the customer was used to control the operating channel as well as the output power level. The RF output power selection is for the setting of RF output expected by the customer and is going to be fixed on the firmware of the final end product.

Table for Parameters of Test Software Setting

Power Setting					
Channel	Frequency (MHz)	250kbps	500kbps	1Mbps	2Mbps
11	2405	Level 0	Level 0	Level 0	Level 0
18	2440	Level 0	Level 0	Level 0	Level 0
26	2480	Level 0	Level 0	Level 0	Level 0

4.2 Carrier Frequency and Channel

Channel	Freq. (MHz)	Channel	Freq. (MHz)
11	2405	19	2445
12	2410	20	2450
13	2415	21	2455
14	2420	22	2460
15	2425	23	2465
16	2430	24	2470
17	2435	25	2475
18	2440	26	2480

4.3 Test Operation and Test Software

Setup for testing: Test samples are provided with a USB interface which makes it possible to control them through a test software installed on a notebook computer.

This software was running on the laptop computer connected to the EUT. It was used to enable the operation modes listed as below.

Test Software	MCHPRT3 v.6710, HUT 5.4.3
---------------	---------------------------

The samples were used as follows:

Radiated test:

PCB Antenna (Ant No. 10):

A003513812-002 (Main Source, ECC), A003513812-009 (Non-ECC), A003513812-011 (2nd Source)

UFL Antenna (Ant No. 5 & 6):

A003513812-001 (Main Source, ECC), A003513812-008 (Non-ECC), A003513812-010 (2nd Source)

PIFA Antenna (Ant No. 3):

A003513812-001 (Main Source, ECC), A003513812-008 (Non-ECC), A003513812-010 (2nd Source)

Conducted test:

A003513812-007 (Main Source), A003513812-012 (2nd Source)

Full test was applied on all test modes, but only worst case was shown.

EUT Configure Mode	Applicable To				Description
	Antenna Port Conducted Measurement	Radiated Spurious Emissions above 1 GHz	Radiated Spurious Emissions below 1 GHz	Mains Conducted Emission	
OnBoard PCB (ECC)	-	√	√	√	-
OnBoard PCB (Non-ECC)	-	-	√	-	-
uFL (ECC)	√	√	√	√	-
uFL (Non-ECC)	-	-	√	-	-
PIFA (ECC)	-	√	√	√	-
PIFA (Non-ECC)	-	-	√	-	-

Note:

- The EUT had been pre-tested on the positioned of each 3 axis. The worst case was found when position on Y-plane.
- "-" means no effect.
- For the 2nd source, we only evaluate the worst case of the output power and RSE tests.
- ECC (Trust and Go IC)

Antenna Port Conducted Measurement

Pre-Scan full test was applied on all test modes, but only worst case was shown.

Following channel(s) was (were) selected for the final test as listed below.

EUT Configure Mode	Available Frequency (MHz)	Tested Frequency (MHz)	Date Rate (Mbps)
uFL (ECC)	2405 to 2480	2405, 2440, 2480	0.25
	2405 to 2480	2405, 2440, 2480	0.50
	2405 to 2480	2405, 2440, 2480	1
	2405 to 2480	2405, 2440, 2480	2

Radiated Spurious Emissions (Above 1 GHz)

- Pre-Scan full test was applied on all test modes, but only worst case was shown.
 Following channel(s) was (were) selected for the final test as listed below.

EUT Configure Mode	Available Frequency (MHz)	Tested Frequency (MHz)	Date Rate (Mbps)
OnBoard PCB (ECC)	2405 to 2480	2405, 2440, 2480	0.25
	2405 to 2480	2405, 2440, 2480	1
uFL (ECC)	2405 to 2480	2405, 2440, 2480	0.25
	2405 to 2480	2405, 2440, 2480	1
PIFA (ECC)	2405 to 2480	2405, 2440, 2480	0.25
	2405 to 2480	2405, 2440, 2480	1

Radiated Spurious Emissions (Below 1 GHz)

- Pre-Scan full test was applied on all test modes, but only worst case was shown.
 Following channel(s) was (were) selected for the final test as listed below.

EUT Configure Mode	Available Frequency (MHz)	Tested Frequency (MHz)	Date Rate (Mbps)
OnBoard PCB (ECC), OnBoard PCB (Non-ECC)	2405 to 2480	2480	0.25
uFL (ECC), uFL (Non-ECC)	2405 to 2480	2480	0.25
PIFA (ECC), PIFA (Non-ECC)	2405 to 2480	2480	0.25

Mains Conducted Emission

- Pre-Scan full test was applied on all test modes, but only worst case was shown.
 Following channel(s) was (were) selected for the final test as listed below.

EUT Configure Mode	Available Frequency (MHz)	Tested Frequency (MHz)	Date Rate (Mbps)
OnBoard PCB (ECC)	2405 to 2480	2480	0.25
uFL (ECC)	2405 to 2480	2480	0.25
PIFA (ECC)	2405 to 2480	2480	0.25

Test Condition

Test Item	Ambient Temperature	Relative Humidity	Tested by
Conducted Measurement	22.5-24.5 °C	58-62 %	Blake Wang
Radiated Spurious Emissions above 1 GHz	22.6-24.5 °C	52-54 %	Roger Liao
Radiated Spurious Emissions below 1 GHz	22.6-24.5 °C	52-54 %	Roger Liao
Mains Conducted Emission	19.1-25.9 °C	50.2-58.9 %	Ray Huang

4.4 Special Accessories and Auxiliary Equipment

The product has been tested together with the following additional accessories:

Accessory of EUT

None.

Support Unit

No.	Description	Brand	Model	S/N	Remark
Conducted Test					
-	Notebook	HP	TPN-C135	CND9111MY2	NB-13
PCB Antenna (ECC/Non-ECC Mode)					
Radiated Test					
1	USB to Micro	TUV	TUV-01	-	50cm non-shielded cable w/o core
2	USB to USB	TUV	TUV-02	-	300 cm non-shielded cable w/o core
3	Notebook	Lenovo	81BL	MP1DCD6Y	-
Mains Conducted Test					
1	Adapter	HP	PPP009D	-	179cm shielded cable w/o core
2	Notebook	Lenovo	81BL	MP1DCD6Y	-
3	USB to Micro	TUV	TUV-01	-	50cm non-shielded cable w/o core
UFL Antenna (ECC/Non-ECC Mode)					
Radiated Test, Ant No. 5					
A	PCB Antenna	Molex	1461530100	-	100mm (Dual Band) A00310881-020
1	USB to Micro	TUV	TUV-01	-	50cm non-shielded cable w/o core
2	USB to USB	TUV	TUV-02	-	300 cm non-shielded cable w/o core
3	Notebook	Lenovo	81BL	MP1DCD6Y	-
Mains Conducted Test, Ant No. 5					
A	PCB Antenna	Molex	1461530100	-	100mm (Dual Band) A00310881-020
1	Adapter	HP	PPP009D	-	179 cm shielded cable w/o core
2	Notebook	Lenovo	81BL	MP1DCD6Y	-
3	USB to Micro	TUV	TUV-01	-	50cm non-shielded cable w/o core
Radiated Test, Ant No. 6					
A	Dipoel Antenna	Linx Technologies	ANT-2.4-LPW-125	-	125mm A003130881-021
1	USB to Micro	TUV	TUV-01	-	50cm non-shielded cable w/o core
2	USB to USB	TUV	TUV-02	-	300 cm non-shielded cable w/o core

3	Notebook	Lenovo	81BL	MP1DCD6Y	-
Mains Conducted Test, Ant No. 6					
A	Dipoel Antenna	Linx Technologies	ANT-2.4-LPW-125	-	125mm A003130881-021
1	Adapter	HP	PPP009D	-	179cm shielded cable w/o core
2	Notebook	Lenovo	81BL	MP1DCD6Y	-
3	USB to Micro	TUV	TUV-01	-	50cm non-shielded cable w/o core
PIFA Antenna (ECC/Non-ECC Mode)					
Radiated Test, Ant No. 3					
A	PIFA Antenna	Laird	001-0016	-	100mm A003119783-011
1	USB to Micro	TUV	TUV-01	-	50cm non-shielded cable w/o core
2	USB to USB	TUV	TUV-02	-	300cm non-shielded cable w/o core
3	Notebook	Lenovo	81BL	MP1DCD6Y	-
Mains Conducted Test, Ant No. 3					
A	PIFA Antenna	Laird	001-0016	-	100mm A003119783-011
1	Adapter	HP	PPP009D	-	179cm shielded cable w/o core
2	Notebook	Lenovo	81BL	MP1DCD6Y	-
3	USB to Micro	TUV	TUV-001	-	300cm non-shielded cable w/o core

4.5 Test Setup Diagram

<Radiated Spurious Emissions for PCB Antenna (ECC/Non-ECC Mode)>

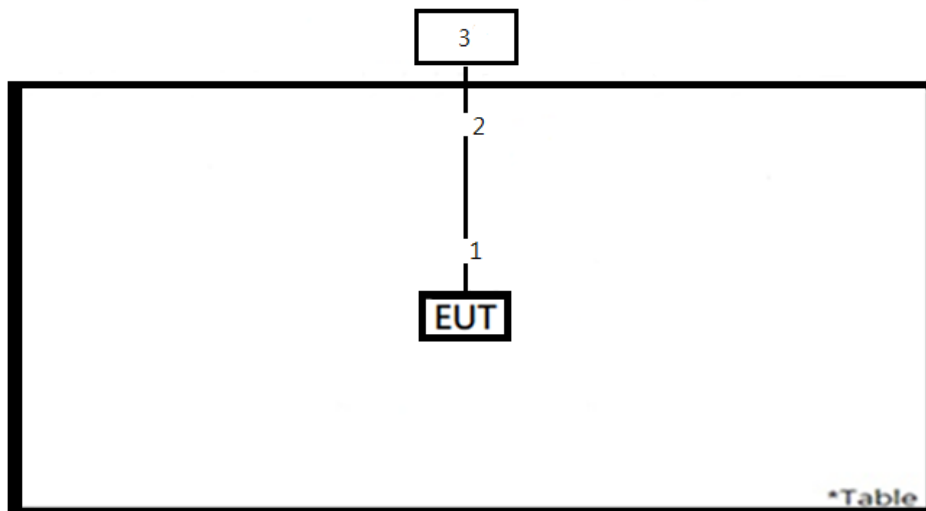

<Mains Conducted Emission for PCB Antenna (ECC Mode)>

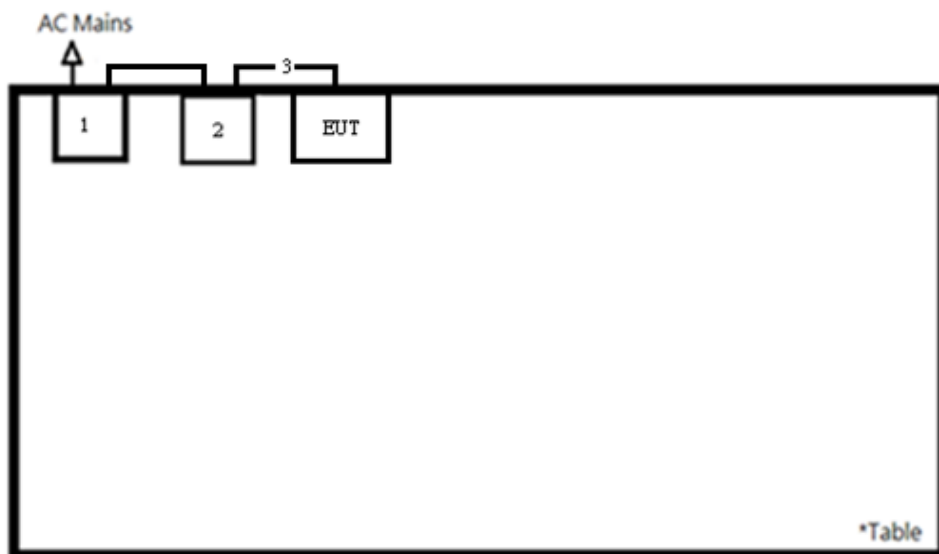

<Radiated Spurious Emissions for UFL Antenna (ECC/Non-ECC Mode)>

Ant No. 5

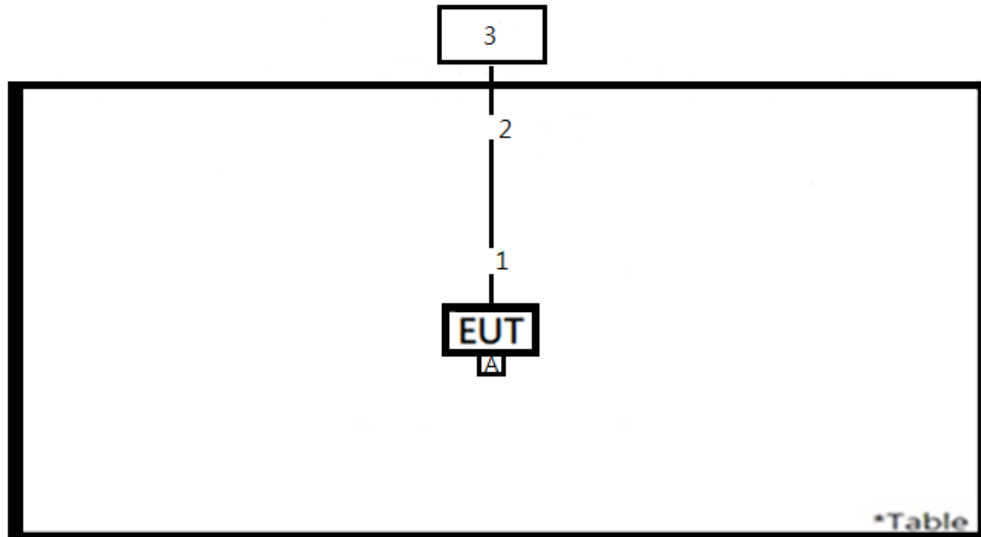

Ant No. 6

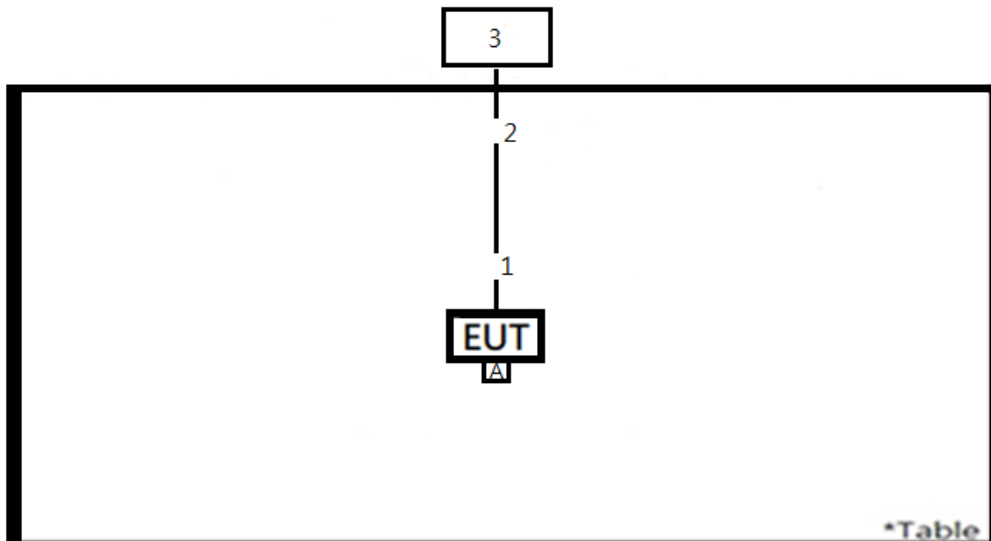

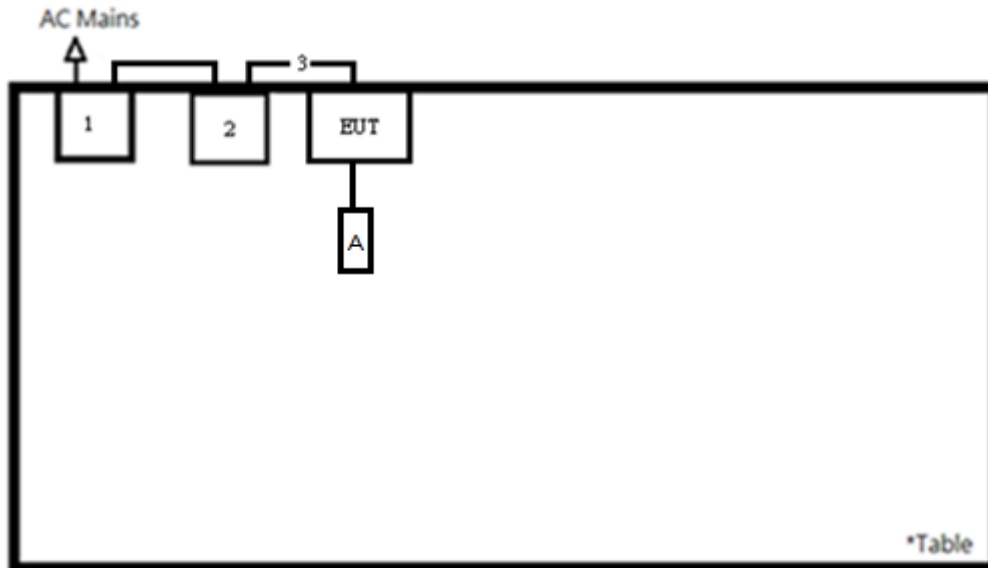
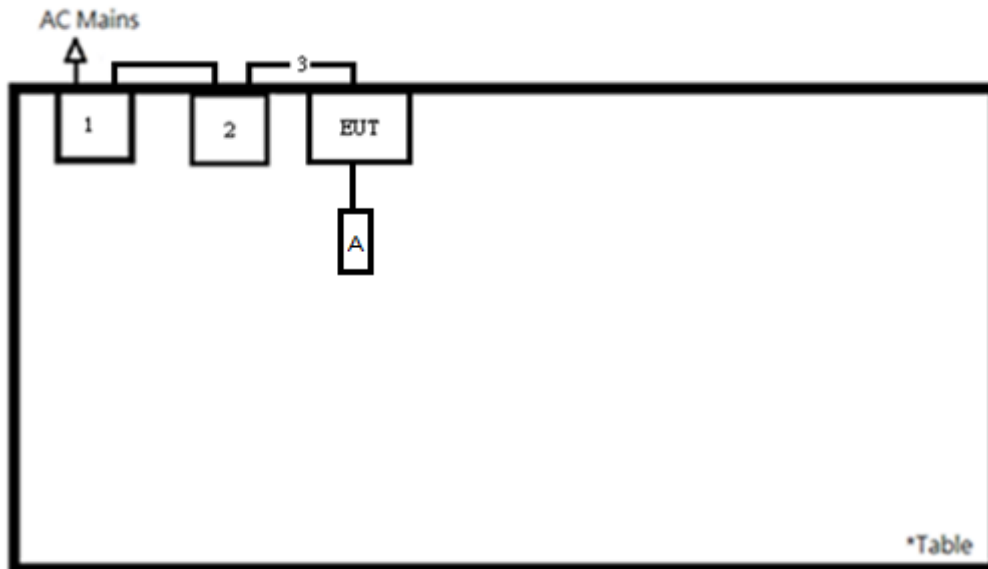
<Mains Conducted Emission for UFL Antenna (ECC/Non-ECC Mode)>
Ant No. 5

Ant No. 6

<Radiated Spurious Emissions for PIFA Antenna (ECC/Non-ECC Mode)>

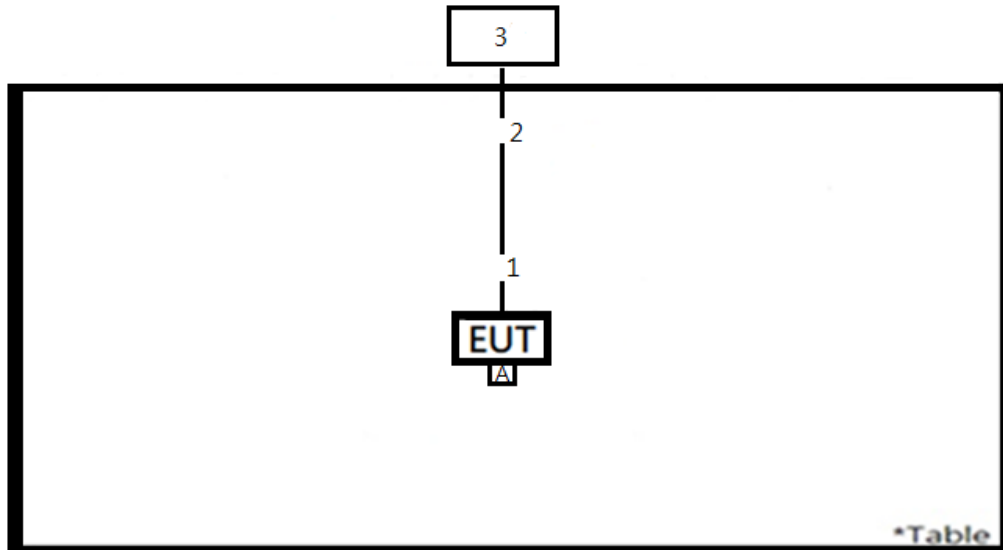
Ant No. 3



<Mains Conducted Emission for PIFA Antenna (ECC/Non-ECC Mode)>

Ant No. 3

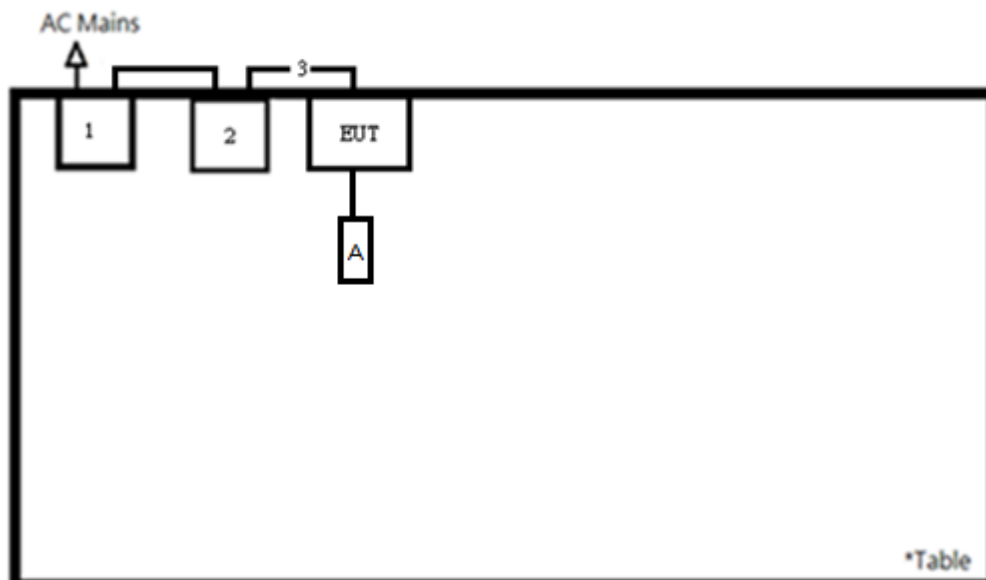

5. Test Results

5.1 Transmitter Requirement & Test Suites

5.1.1 Antenna Requirement

Requirement Use of approved antennas only

According to the manufacturer declaration, the antenna information is as listed below.
 The antenna is with no possibility of replacement with a non-approved antenna by the end-user.
 Therefore, the EUT is considered to comply with this provision.

ANT No.	Brand Name	SN/Model #	Cable Length (mm)	Type	Gain (dBi)	Placement	Remark
1	Pulse	W3525B039	100	PCB	2	External	Applied to model no. WBZ351UE and WBZ351UC
2	PSA	RFDPA870915IMAB306	150	Dipole	1.82	External	
3	Laird	001-0016	100	PIFA	2.5	External	
4	LSR	001-0001	RPSMA connector	Dipole	2	External	
5	Molex	1461530100	100 (Dual Band)	PCB	3	External	
6	Linx	ANT-2.4-LPW-125	125	Dipole	2.8	External	
7	ALEAD	RFA-02-P05-D034	150	PCB	2	External	
8	ALEAD	RFA-02-P33-D034	150	PCB	2	External	
9	ABRACON	ABAR1504-S2450	250	PCB	2.28	External	
10	Microchip	WBZ350	-	PCB	2.9	Internal	Applied to model no. WBZ351PE and WBZ351PC

5.1.2 Peak Output Power

Limit 1 watt (30 dBm)

Kind of Test Site Shielded room

Test Setup



Test Instruments

Kind of Equipment	Manufacturer	Type	S/N	Calibration Date	Calibration Due Date	Test Date	
						From	Until
Power Meter	Anritsu	ML2495A	1901008	2023/3/17	2024/3/15	2023/7/24	2023/7/24
Power Sensor	Anritsu	MA2411B	1725269	2023/3/17	2024/3/15	2023/7/24	2023/7/24

Test Procedures

A peak power sensor was used on the output port of the EUT. A power meter was used to read the response of the peak power sensor. Record the power level.

Average power sensor was used to perform output power measurement, trigger and gating function of wide band power meter is enabled to measure max output power of TX on burst. Duty factor is not added to measured value.

Test Result
Peak Output Power
<250kbps>

Channel	Channel Frequency	Peak Output Power		Limit (dBm)
	(MHz)	(dBm)	(mW)	
11	2405	11.65	14.62	30
18	2440	11.63	14.55	30
26	2480	11.60	14.45	30

<500kbps>

Channel	Channel Frequency	Peak Output Power		Limit (dBm)
	(MHz)	(dBm)	(mW)	
11	2405	11.64	14.59	30
18	2440	11.62	14.52	30
26	2480	11.59	14.42	30

<1Mbps>

Channel	Channel Frequency	Peak Output Power		Limit (dBm)
	(MHz)	(dBm)	(mW)	
11	2405	11.65	14.62	30
18	2440	11.63	14.55	30
26	2480	11.59	14.42	30

<2Mbps>

Channel	Channel Frequency	Peak Output Power		Limit (dBm)
	(MHz)	(dBm)	(mW)	
11	2405	11.64	14.59	30
18	2440	11.62	14.52	30
26	2480	11.58	14.39	30

<250kbps, 2nd Source>

Channel	Channel Frequency	Peak Output Power		Limit (dBm)
	(MHz)	(dBm)	(mW)	
11	2405	11.56	14.32	30
18	2440	11.53	14.22	30
26	2480	11.50	14.13	30

<500kbps, 2nd Source>

Channel	Channel Frequency	Peak Output Power		Limit (dBm)
	(MHz)	(dBm)	(mW)	
11	2405	11.54	14.26	30
18	2440	11.52	14.19	30
26	2480	11.49	14.09	30

<1Mbps, 2nd Source>

Channel	Channel Frequency	Peak Output Power		Limit (dBm)
	(MHz)	(dBm)	(mW)	
11	2405	11.56	14.32	30
18	2440	11.53	14.22	30
26	2480	11.50	14.13	30

<2Mbps, 2nd Source>

Channel	Channel Frequency	Peak Output Power		Limit (dBm)
	(MHz)	(dBm)	(mW)	
11	2405	11.54	14.26	30
18	2440	11.52	14.19	30
26	2480	11.49	14.09	30

Average Power
<250kbps>

Channel	Channel Frequency	Average Power	
	(MHz)	(dBm)	(mW)
11	2405	11.60	14.45
18	2440	11.59	14.42
26	2480	11.56	14.32

<500kbps>

Channel	Channel Frequency	Average Power	
	(MHz)	(dBm)	(mW)
11	2405	11.59	14.42
18	2440	11.58	14.39
26	2480	11.55	14.29

<1Mbps>

Channel	Channel Frequency	Average Power	
	(MHz)	(dBm)	(mW)
11	2405	11.60	14.45
18	2440	11.59	14.42
26	2480	11.55	14.29

<2Mbps>

Channel	Channel Frequency	Average Power	
	(MHz)	(dBm)	(mW)
11	2405	11.59	14.42
18	2440	11.58	14.39
26	2480	11.54	14.26

Average Power
<250kbps, 2nd Source>

Channel	Channel Frequency	Average Power	
	(MHz)	(dBm)	(mW)
11	2405	11.50	14.13
18	2440	11.48	14.06
26	2480	11.45	13.96

<500kbps, 2nd Source>

Channel	Channel Frequency	Average Power	
	(MHz)	(dBm)	(mW)
11	2405	11.49	14.09
18	2440	11.47	14.03
26	2480	11.44	13.93

<1Mbps, 2nd Source>

Channel	Channel Frequency	Average Power	
	(MHz)	(dBm)	(mW)
11	2405	11.50	14.13
18	2440	11.48	14.06
26	2480	11.45	13.96

<2Mbps, 2nd Source>

Channel	Channel Frequency	Average Power	
	(MHz)	(dBm)	(mW)
11	2405	11.49	14.09
18	2440	11.47	14.03
26	2480	11.44	13.93

5.1.3 6 dB Bandwidth and 99% Occupied Bandwidth

Limit The minimum 6 dB bandwidth shall be at least 500 kHz.

Kind of Test Site Shielded room

Test Setup

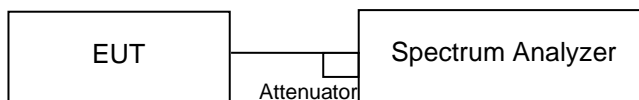

Test Instruments

Kind of Equipment	Manufacturer	Type	S/N	Calibration Date	Calibration Due Date	Test Date	
						From	Until
Spectrum Analyzer	R&S	FSV	101513	2023/5/10	2024/5/8	2023/7/24	2023/7/24

Test Procedure

- a. Set resolution bandwidth (RBW) = 100 kHz
- b. Set the video bandwidth (VBW) $\geq 3 \times$ RBW, Detector = Peak.
- c. Trace mode = max hold.
- d. Sweep = auto couple.
- e. Measure the maximum width of the emission that is constrained by the frequencies associated with the two amplitude points (upper and lower) that are attenuated by 6 dB relative to the maximum level measured in the fundamental emission.
- f. For 99% occupied bandwidth measurement, the transmitter output was connected to the spectrum analyzer through an attenuator. The bandwidth of the fundamental frequency was measured by spectrum analyzer with resolution bandwidth in the range of 1% to 5% of the anticipated emission bandwidth, and a video bandwidth at least 3x the resolution bandwidth and set the detector to PEAK. The width of a frequency band such that, below the lower and above the upper frequency limits, the mean powers emitted are each equal to a specified percentage 0.5% of the total mean power of a given emission.

Test Results

Please refer to Appendix A.

5.1.4 Power Spectral Density

Limit

The power spectral density shall not be greater than 8 dBm in any 3 kHz band.

Kind of Test Site Shielded room

Test Setup

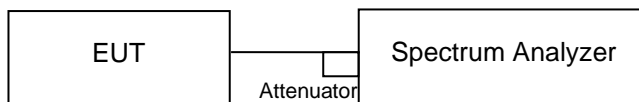

Test Instruments

Kind of Equipment	Manufacturer	Type	S/N	Calibration Date	Calibration Due Date	Test Date	
						From	Until
Spectrum Analyzer	R&S	FSV	101513	2023/5/10	2024/5/8	2023/7/24	2023/7/24

Test Procedure

- a. Set analyzer center frequency to DTS channel center frequency.
- b. Set the span to 1.5 times the DTS bandwidth.
- c. Set the RBW to: $3 \text{ kHz} \leq \text{RBW} \leq 100 \text{ kHz}$.
- d. Set the VBW $\geq 3 \times \text{RBW}$.
- e. Detector = peak.
- f. Sweep time = auto couple.
- g. Trace mode = max hold.
- h. Allow trace to fully stabilize.
- i. Use the peak marker function to determine the maximum amplitude level within the RBW.

Test Results

Please refer to Appendix A.

5.1.5 Conducted Spurious Emissions and Frequency Band Edges Measured in 100kHz Bandwidth

Limit

20dB (below that in the 100 kHz bandwidth within the band that contains the highest level of the desired power.)

Kind of Test Site Shielded room

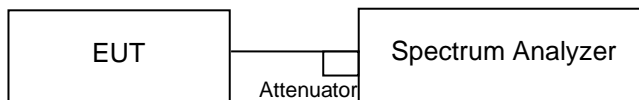
Test Setup

Test Instruments

Kind of Equipment	Manufacturer	Type	S/N	Calibration Date	Calibration Due Date	Test Date	
						From	Until
Spectrum Analyzer	R&S	FSV	101513	2023/5/10	2024/5/8	2023/7/24	2023/7/24

Test Procedure

Measurement procedure REF

1. Set the RBW = 100 kHz.
2. Set the VBW \geq 300 kHz.
3. Detector = peak.
4. Sweep time = auto couple.
5. Trace mode = max hold.
6. Allow trace to fully stabilize.
7. Use the peak marker function to determine the maximum power level in any 100 kHz band segment within the fundamental EBW.

Measurement procedure OOBE

1. Set RBW = 100 kHz.
2. Set VBW \geq 300 kHz.
3. Detector = peak.
4. Sweep = auto couple.
5. Trace Mode = max hold.
6. Allow trace to fully stabilize.
7. Use the peak marker function to determine the maximum amplitude level.

Test Results

Please refer to Appendix A.

5.1.6 Radiated Spurious Emissions and Band Edges

Limit

Radiated emissions which fall in the restricted bands, as defined in §15.205(a), must comply with the radiated emission limits specified in §15.209(a).

Emissions radiated outside the restricted and authorized frequency bands must either comply with the radiated emission limits specified for the restricted bands or in §15.247(d).

Kind of Test Site 3m Semi-Anechoic Chamber

Test Setup

<Radiated Emissions below 30 MHz>

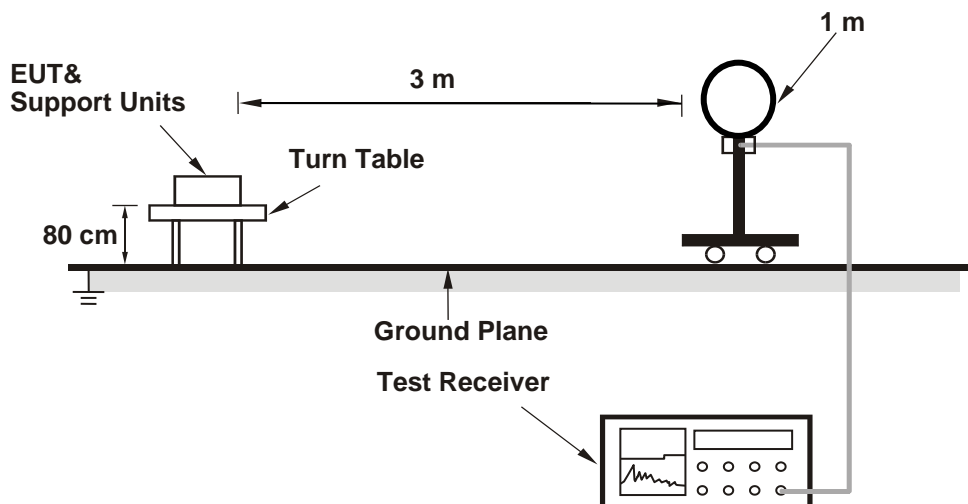

<Radiated Emissions 30 MHz to 1 GHz>

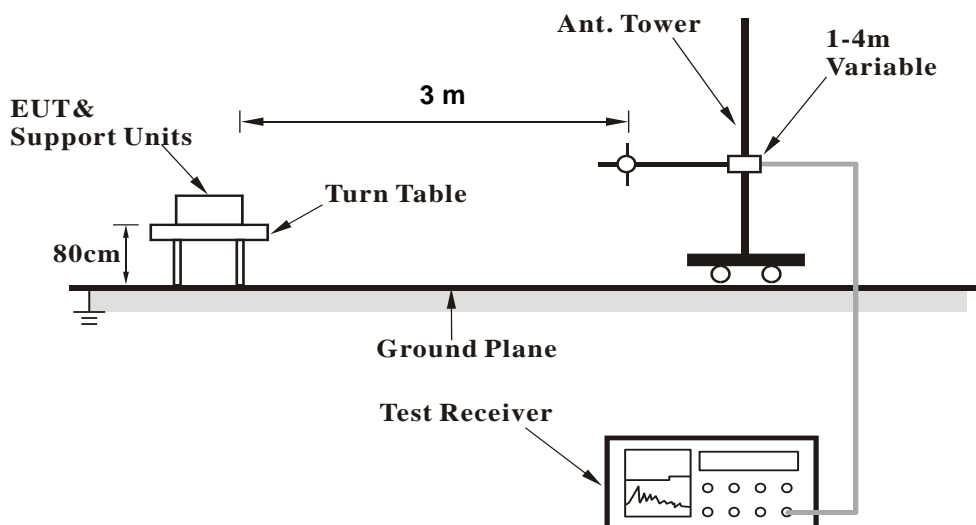

<Radiated Emissions above 1 GHz>

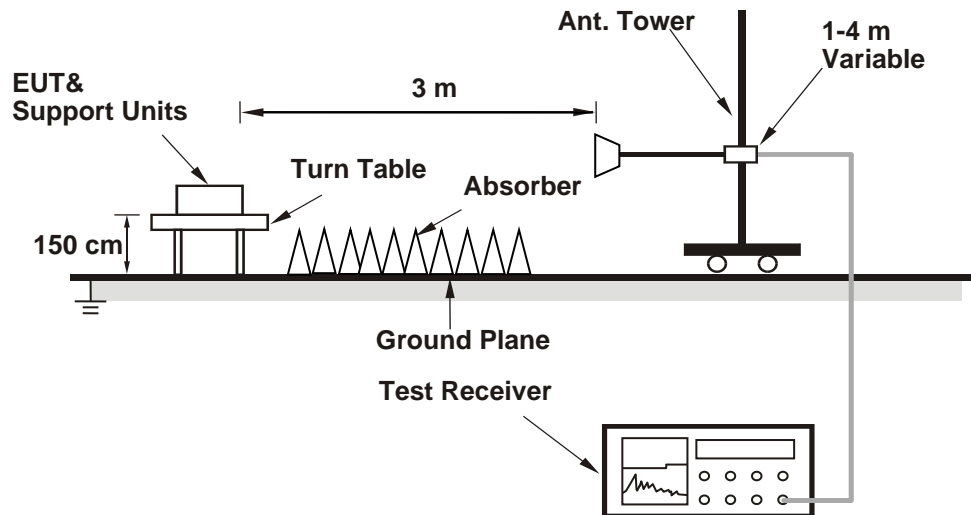

For the actual test configuration, please refer to the attached file (Test Setup Photo).

Test Instruments

Test Date: 2023/7/15 ~ 2023/8/16, 2023/10/6

Kind of Equipment	Manufacturer	Type	S/N	Calibration Date	Calibration Due Date
Above 1GHz					
Signal Analyzer	R&S	FSV40	101509	2023/4/26	2024/4/24
Horn Antenna	ETS-Lindgren	3117	00218929	2022/11/17	2023/11/16
Horn Antenna	SCHWARZBECK	BBHA 9170	00890	2023/5/4	2024/5/2
HF-AMP + AC source	EMCI	EMC051845SE	980635	2023/2/16	2024/2/15
HF-AMP + AC source	EMCI	EMC051845SE	980656	2023/1/16	2024/1/15
30MHz-1GHz					
Receiver	R&S	ESR7	102109	2023/2/24	2024/2/23
Bilog Antenna	SCHWARZBECK	VULB-9168	00951	2023/3/31	2024/3/29
LF-AMP	Agilent	8447D	2944A107722	2023/3/22	2024/3/20
Below 30MHz					
Receiver	R&S	ESR7	102109	2023/2/24	2024/2/23
Loop Antenna	SCHWARZBECK	FMZB 1519B	00215	2023/1/4	2024/1/3

Test Procedures**For Radiated Emissions below 30 MHz**

- a. The EUT was placed on the top of a rotating table 0.8 meters above the ground at a 3 meter chamber room. The table was rotated 360 degrees to determine the position of the highest radiation.
- b. The EUT was set 3 meters away from the interference-receiving antenna, which was mounted on the top of a variable-height antenna tower.
- c. Parallel (OPEN), perpendicular (CLOSE), and ground-parallel (GROUND) orientations of the antenna are set to make the measurement.
- d. For each suspected emission, the EUT was arranged to its worst case and the rotatable table was turned from 0 degrees to 360 degrees to find the maximum reading.
- e. The test-receiver system was set to Quasi-Peak Detect Function and Specified Bandwidth with Maximum Hold Mode.

Note:

1. The resolution bandwidth and video bandwidth of test receiver/spectrum analyzer is 9 kHz at frequency below 30 MHz.
2. All modes of operation were investigated and the worst-case emissions are reported.

For Radiated Emissions above 30 MHz

- a. The EUT was placed on the top of a rotating table 0.8 meters (for 30 MHz ~ 1 GHz) / 1.5 meters (for above 1 GHz) above the ground at 3 meter chamber room for test. The table was rotated 360 degrees to determine the position of the highest radiation.
- b. The EUT was set 3 meters away from the interference-receiving antenna, which was mounted on the top of a variable-height antenna tower.
- c. The height of antenna is varied from one meter to four meters above the ground to determine the maximum value of the field strength. Both horizontal and vertical polarizations of the antenna are set to make the measurement.
- d. For each suspected emission, the EUT was arranged to its worst case and then the antenna was tuned to heights from 1 meter to 4 meters and the rotatable table was turned from 0 degrees to 360 degrees to find the maximum reading.
- e. The test-receiver system was set to quasi-peak detect function and specified bandwidth with maximum hold mode when the test frequency is below 1 GHz.
- f. The test-receiver system was set to peak and average detected function and specified bandwidth with maximum hold mode when the test frequency is above 1 GHz. If the peak reading value also meets average limit, measurement with the average detector is unnecessary.

Note:

1. The resolution bandwidth and video bandwidth of test receiver/spectrum analyzer is 120 kHz for Quasi-peak detection (QP) or Peak detection (PK) at frequency below 1 GHz.
2. The resolution bandwidth of test receiver/spectrum analyzer is 1 MHz and the video bandwidth is 3 MHz for Peak detection (PK) at frequency above 1 GHz.
3. The resolution bandwidth of test receiver/spectrum analyzer is 1 MHz and the video bandwidth is $\geq 1/T$ (Duty cycle < 98 %) or 10 Hz (Duty cycle ≥ 98 %) for Average detection (AV) at frequency above 1 GHz.
4. All modes of operation were investigated and the worst-case emissions are reported.
5. The Radiated Emissions testing was performed in the X(E1), Y(H) and Z(E2) axis orientation. The worst-case Axis orientation is recorded in this test report.

Test Results

Factor (dB/m) = Antenna Factor (dB/m) + Cable Loss (dB)

Level (dBuV/m) = Reading (dBuV) + Factor (dB/m)

Please refer to Appendix B for PCB antenna, Appendix C for UFL antennas and Appendix D for PIFA antenna.

5.2 Mains Emission

5.2.1 Mains Conducted Emission

Limit

Mains Conducted Emission as defined in §15.207 must comply with the mains conducted emission limits.

Kind of Test Site Shielded room

Test Setup

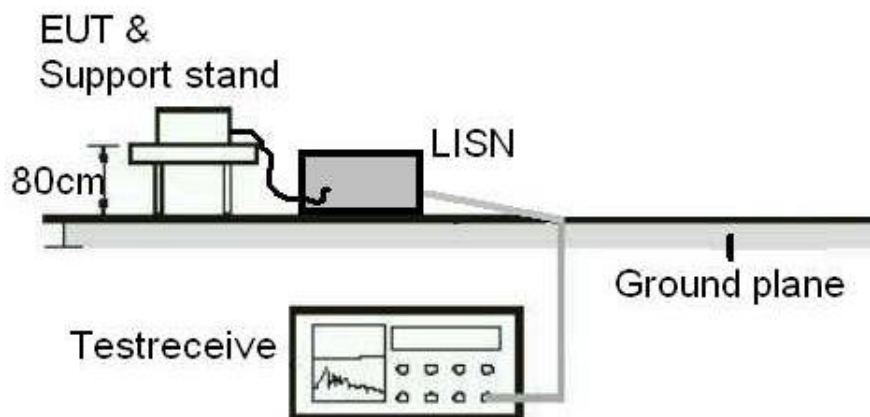

Test Instruments

Test Date: 2023/7/20, 2023/10/6

Kind of Equipment	Manufacturer	Type	S/N	Calibration Date	Calibration Due Date
Two-Line V-Network	Rohde & Schwarz	ENV216	101262	2022/12/26	2023/12/25
EMI Test Receiver	R&S	ESCI	101094	2022/11/24	2023/11/23

Test Procedures

- a. The EUT was placed 0.4 meters from the conducting wall of the shielded room with EUT being connected to the power mains through a line impedance stabilization network (LISN). Other support units were connected to the power mains through another LISN. The two LISNs provide 50 ohm/50 uH of coupling impedance for the measuring instrument.
- b. Both lines of the power mains connected to the EUT were checked for maximum conducted interference.
- c. The frequency range from 150 kHz to 30 MHz was searched. Emission levels under (Limit – 20 dB) was not recorded.

Note: The resolution bandwidth and video bandwidth of test receiver is 9 kHz for quasi-peak detection (QP) and average detection (AV) at frequency 0.15 MHz – 30 MHz.

Test Results

Please refer to Appendix B for PCB antenna, Appendix C for UFL antennas and Appendix D for PIFA antenna.