

Prüfbericht-Nr.: <i>Test Report No.:</i>	50116065 001	Auftrags-Nr.: <i>Order No.:</i>	114071471	Seite 1 von 34 <i>Page 1 of 34</i>	
Kunden-Referenz-Nr.: <i>Client Reference No.:</i>	N/A	Auftragsdatum: <i>Order date:</i>	20-Nov-2017		
Auftraggeber: <i>Client:</i>	Microchip Technology Inc. 2355 West Chandler Blvd. Chandler, Arizona 85224-6199, United States.				
Prüfgegenstand: <i>Test item:</i>	IEEE 802.11 b/g/n Link Controller Module				
Bezeichnung / Typ-Nr.: <i>Identification / Type No.:</i>	ATWILC1000-MR110UB				
Auftrags-Inhalt: <i>Order content:</i>	FCC Part 15C / IC RSS-247 (Class II Permissive Change) Test report (WiFi 2.4GHz) spurious radiated emissions only				
Prüfgrundlage: <i>Test specification:</i>	FCC 47CFR Part 15: Subpart C Section 15.247 RSS-247 (05-2015)				
Wareneingangsdatum: <i>Date of receipt:</i>	20-Nov-2017				
Prüfmuster-Nr.: <i>Test sample No.:</i>	A000654209-005				
Prüfzeitraum: <i>Testing period:</i>	28-Nov-2017 - 07-Mar-2018				
Ort der Prüfung: <i>Place of testing:</i>	EMC Laboratory Taipei				
Prüflaboratorium: <i>Testing laboratory:</i>	TUV Rheinland Taiwan Ltd.				
Prüfergebnis*: <i>Test result*:</i>	Pass				
geprüft von / tested by:			kontrolliert von / reviewed by:		
13-Mar-2018	Jack Chang /Project Manager		13-Mar-2018	Arvin Ho /Vice General Manager	
Datum <i>Date</i>	Name / Stellung <i>Name / Position</i>	Unterschrift <i>Signature</i>	Datum <i>Date</i>	Name / Stellung <i>Name / Position</i>	Unterschrift <i>Signature</i>
Sonstiges / Other: Reference the Test Report D51020R1 of Compatible Electronics Inc.					
Zustand des Prüfgegenstandes bei Anlieferung: <i>Condition of the test item at delivery:</i>			Prüfmuster vollständig und unbeschädigt <i>Test item complete and undamaged</i>		
* Legende: 1 = sehr gut 2 = gut 3 = befriedigend 4 = ausreichend 5 = mangelhaft P(ass) = entspricht o.g. Prüfgrundlage(n) F(ail) = entspricht nicht o.g. Prüfgrundlage(n) N/A = nicht anwendbar N/T = nicht getestet					
Legend: 1 = very good 2 = good 3 = satisfactory 4 = sufficient 5 = poor P(ass) = passed a.m. test specification(s) F(ail) = failed a.m. test specification(s) N/A = not applicable N/T = not tested					
Dieser Prüfbericht bezieht sich nur auf das o.g. Prüfmuster und darf ohne Genehmigung der Prüfstelle nicht auszugsweise vervielfältigt werden. Dieser Bericht berechtigt nicht zur Verwendung eines Prüfzeichens. <i>This test report only relates to the a. m. test sample. Without permission of the test center this test report is not permitted to be duplicated in extracts. This test report does not entitle to carry any test mark.</i>					

TEST SUMMARY

5.1.1 6dB BANDWIDTH AND 99% BANDWIDTH

RESULT: Passed

5.1.2 SPURIOUS EMISSION

RESULT: Passed

Contents

1.	GENERAL REMARKS	4
1.1	COMPLEMENTARY MATERIALS.....	4
2.	TEST SITES	5
2.1	TEST LABORATORY	5
2.2	TEST FACILITIES.....	5
2.3	LIST OF TEST AND MEASUREMENT INSTRUMENTS.....	6
2.4	TRACEABILITY	7
2.5	CALIBRATION	7
2.6	MEASUREMENT UNCERTAINTY	7
3.	GENERAL PRODUCT INFORMATION.....	8
3.1	PRODUCT FUNCTION AND INTENDED USE	8
3.2	SYSTEM DETAILS AND RATINGS.....	8
3.3	INDEPENDENT OPERATION MODES.....	11
3.4	NOISE GENERATING AND NOISE SUPPRESSING PARTS	11
3.5	SUBMITTED DOCUMENTS.....	11
4.	TEST SET-UP AND OPERATION MODES.....	12
4.1	PRINCIPLE OF CONFIGURATION SELECTION	12
4.2	TEST OPERATION AND TEST SOFTWARE.....	12
4.3	CIAL ACCESSORIES AND AUXILIARY EQUIPMENT	13
4.4	COUNTERMEASURES TO ACHIEVE EMC COMPLIANCE.....	13
4.5	TEST SETUP DIAGRAM	13
5.	TEST RESULTS	15
5.1	TRANSMITTER REQUIREMENT & TEST SUITES	15
5.1.1	<i>6dB Bandwidth and 99% Bandwidth.....</i>	<i>15</i>
5.1.2	<i>Spurious Emission</i>	<i>22</i>
6.	PHOTOGRAPHS OF THE TEST SET-UP.....	23
7.	LIST OF TABLES	34
8.	LIST OF PHOTOGRAPHS.....	34

1. General Remarks

1.1 Complementary Materials

The following attachments are integral parts of this test report:

Appendix P: Photo Documentation
(File Name: 50116065APPENDIX P)

Appendix D: Test Result of Radiated Emissions
(File Name: 50116065APPENDIX D)

Test Specifications

The following standards were applied (in bold: product standards, otherwise: basic standards).

Table 1: Applied Standard and Test Levels

Radio

FCC CFR47 Part 15: Subpart C Section 15.247

RSS-247 Issue 1 May 2015

RSS-Gen, Issue 4, November 2014

ANSI C63.10:2013

KDB558074 D01 DTS Meas Guidance v03r05
--

2. Test Sites

2.1 Test Laboratory

TUV Rheinland Taiwan Ltd.
Taichung Branch Office

No.9, Lane 36, Minsheng Rd., Sec. 3, Daya District,
Taichung City 428
Taiwan (R.O.C.)

2.2 Test Facilities

TUV Rheinland Taiwan Ltd.
Taipei Office

11F. No.758, Sec. 4, Bade Rd., Songshan Dist.
Taipei City 105
Taiwan (R.O.C.)

FCC RegistrationNo.: 340738
IC Canada Registration No.: 9465A-1
TAF Accredited NCC Test Lab. No.:0759
TAF ISO17025 Certification effective periods: 2016-Jul-1st to 2019-Jun-30th



Testing Laboratory
0759

2.3 List of Test and Measurement Instruments

Table 2: List of Test and Measurement Equipment

Kind of Equipment	Manu-facturer	Type	S/N	Last Calibration	Next Calibration
Test Software	Farad	EZ_EMC	Ver. TUV3A1	N/A	N/A
EMI Test Receiver	R&S	ESR7	101062	2017/09/25	2018/09/25
Spectrum Analyzer	R&S	FSV 40	100921	2017/05/02	2018/05/02
Spectrum Analyzer	Agilent	N9010A	MY53470241	2017/05/23	2018/05/23
Preamplifier (30MHz -1GHz)	HP	8447F	2805A03335	2017/08/14	2018/08/14
Preamplifier (18 GHz -40 GHz)	COM-POWER	PAM-840	461257	2016/12/01	2018/03/31
Pre-Amplifier (1GHz~18GHz)	EM Electronics	EM01G18G	060649	2017/07/28	2018/07/28
Bilog Antenna	TESEQ	CBL6111D	29802	2017/07/12	2018/07/12
Horn Antenna	ETS-Lindgren	3117	138160	2017/05/25	2018/05/25
Horn Antenna (18GHz~40GHz)	COM-POWER	AH840	101031	2017/11/28	2018/11/28
Loop Antenna	Schwarzbeck	FMZB 1513	1513-076	2017/06/14	2018/06/14
Spectrum Analyzer	R&S	FSV-40	100921	2017/05/02	2018/05/02
Temp. & Humid. Chamber	WISEWIND	1509	509Q24R	2017/05/24	2018/05/24
LISN (1 phase)	R&S	ENV216	101243	2017/05/24	2018/05/24
LISN	R&S	ENV216	101262	2017/06/22	2018/06/22
Test Software	Audix	e3	Ver. 9	N/A	N/A

2.4 Traceability

All measurement equipment calibrations are traceable to NML(Taiwan)/NIST(USA) or where calibration is performed outside Taiwan, to equivalent nationally recognized standards organizations.

2.5 Calibration

Equipment requiring calibration is calibrated periodically by the manufacturer or according to manufacturer's specifications. Additionally all equipment is verified for proper performance on a regular basis using in house standards or comparisons.

2.6 Measurement Uncertainty

The estimated combined standard uncertainty for radiated emissions and conducted emissions measurements are ± 3 dB.

Table 3: Emission Measurement Uncertainty

Parameter	Uncertainty
RF power, conducted	± 1.5 dB
Adjacent channel power	± 3 dB
Radiated emission of transmitter, valid up to 26 GHz	± 6 dB
Radiated emission of receiver, valid up to 26 GHz	± 6 dB
Temperature	± 2 °C
Humidity	± 10 %

3. General Product Information

3.1 Product Function and Intended Use

The EUT is an IEEE 802.11 b/g/n Link Controller Module. The Module has RF Shield and u.FL connector due External Antenna(s).
For details refer to the User Guide, Data Sheet and Circuit Diagram.

3.2 System Details and Ratings

Table 4: Basic Information of EUT

Item	EUT information
Kind of Equipment	IEEE 802.11 b/g/n Link Controller Module
Type Designation	ATWILC1000-MR110UB
Brand Name	Microchip
FCC ID	2ADHKATWILC1000U
Canada ID	20266-WILC1000UB
Canada HVIN	ATWILC1000-MR110UB

Table 5: Technical Specification of EUT

Technical Specification	Value
Operating Frequencies	2412 MHz ~ 2462 MHz
Channel Spacing	20 MHz
Channel number	802.11b/g/n : 11 (2412 MHz ~ 2462 MHz)
Operation Voltage	3.0V to 4.2V (Typical = 3.3v)
Modulation	802.11b: DSSS ; 802.11g/n: OFDM
Antenna gain	Refer below antenna list

Table 6: External Antenna list
Antennas no.4, 6 and 9 selected for testing and no. 3, 8, 11, 12 selected for spot check

Sino.	P/N	Vendor	Antenna Gain @ 2.4GHz Band	Antenna type	Remarks
1	W3525B039 (Used in Original certification)	Pulse Electronics Corporation	2 dBi	PCB	Cable length 100mm
2	RN-SMA-4	Microchip	2.2 dBi	Dipole	
3	RFDPA870920IMLB301	WALSIN	1.84 dBi	Dipole-DB	Dual Band
4	RFMTA331215IMAB701	WALSIN	3.8 dBi	PIFA (Metal Stamp)	Cable length 150mm
5	RFMTA331240IMAB701	WALSIN	3.0 dBi	PIFA (Metal Stamp)	Antenna same as SIno.4, cable length 400 mm
6	RFPCA381013IMAB701	WALSIN	4.50 dBi	PCB	Cable length 130mm
7	RFPCA381035IMAB701	WALSIN	2.7 dBi	PCB	Antenna same as SIno.6, cable length 350mm
8	RFA-02-3-C5H1	Aristotle	3 dBi	Dipole	
9	RFA-02-5-C7H1	Aristotle	5 dBi	Dipole-Long	
10	RFA-02-P33	Aristotle	2 dBi	PCB	Cable length 150mm
11	1461530100	Molex	3 dBi	PCB/Flexi	Cable length 100mm Dual Band
12	RN-SMA-S	Microchip	0.56 dBi	Dipole-short	
13	RN-SMA-7	Microchip	5 dBi	Dipole-Long	
14	RFA-02-5-F7H1	Aristotle	5 dBi	Dipole-Long	
15	RFA-02-D3	Aristotle	2 dBi	Dipole-no encl.	
16	RFA-02-G03	Aristotle	2 dBi	PIFA (Metal Stamp)	Cable length 150mm
17	RFA-02-L2H1	Aristotle	2 dBi	Dipole	
18	RFA-02-P05	Aristotle	2 dBi	PCB	Cable length 150mm
19	RFA-02-C2M2	Aristotle	2 dBi	Dipole	

3.3 Independent Operation Modes

Basic operation modes are:

- A. Transmitting
 - 1. Low channel
 - 2. Middle channel
 - 3. High channel
- B. Receiving
- C. Standby
- D. Off

3.4 Noise Generating and Noise Suppressing Parts

Refer to the Circuit Diagram.

3.5 Submitted Documents

- Bill of Material
- PCB Layout
- Photo Document
- Technical Description
- Circuit Diagram
- Instruction Manual
- Rating Label

4. Test Set-up and Operation Modes

4.1 Principle of Configuration Selection

The equipment under test (EUT) was configured to measure its maximum power level. The test modes were adapted accordingly in reference to the instructions for use.

4.2 Test Operation and Test Software

Setup for testing: Test samples are provided with an I2C to USB Adaptor which makes it possible to control them through the test software installed on a notebook computer.

This software was running on the laptop computer connected to the EUT. It was used to enable the operation modes listed in section 3.3 as appropriate.

The samples were used as follows:

Radiation: A000654209-005

Full test was applied on all test modes, but only worst case was shown

IEEE 802.11b mode:

Channel Low (2412MHz), Channel Mid (2437MHz) and Channel High (2462MHz) with 1Mbps data rate were chosen for full testing.

IEEE 802.11g mode:

Channel Low (2412MHz), Channel Mid (2437MHz) and Channel High (2462MHz) with 6Mbps data rate were chosen for full testing.

IEEE 802.11n HT 20 mode:

Channel Low (2412MHz), Channel Mid (2437MHz) and Channel High (2462MHz) with 6.5Mbps data rate were chosen for full testing.

IEEE 802.11g mode (Spot check):

Based on External Antenna list, Channel Mid (2437MHz) with 6Mbps data rate were chosen for spot check test.

4.3 Special Accessories and Auxiliary Equipment

The product has been tested together with the following additional accessories:

Description	Manufacturer	Model No.	Serial No.
Notebook(EMC-06)	Lenovo	TP00048A	PB-0F8B2

4.4 Countermeasures to achieve EMC Compliance

The test sample which has been tested contained the noise suppression parts as described in the Constructional Data Form or the Technical Construction File. No additional measures were employed to achieve compliance.

4.5 Test Setup Diagram

Diagram of Measurement Configuration for Radiation Test

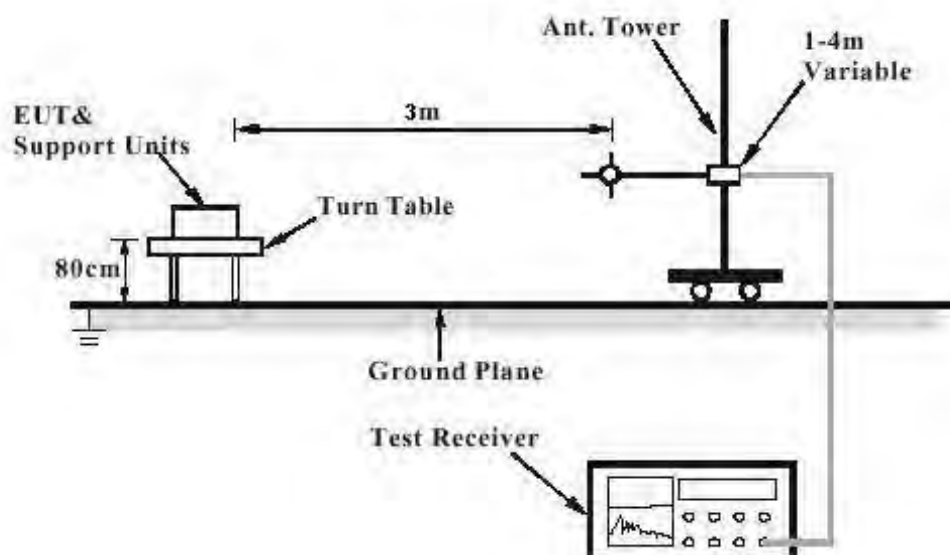

Note: Measurements above 1 GHz are done with a table height of 1.5m.

Diagram of Measurement Equipment Configuration for Mains Conduction Measurement (if applicable)

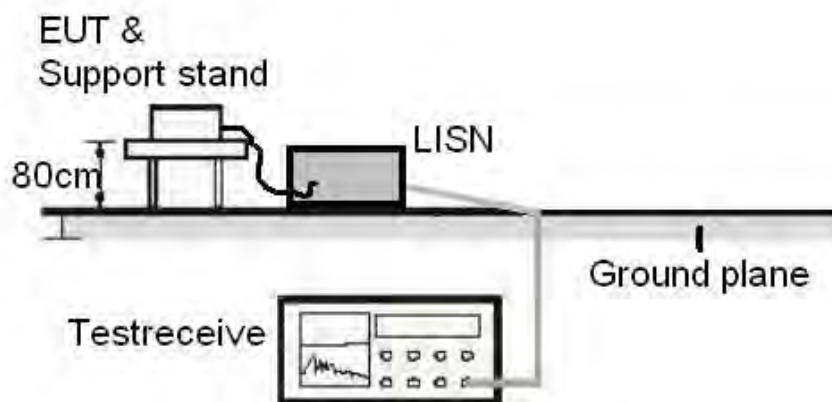
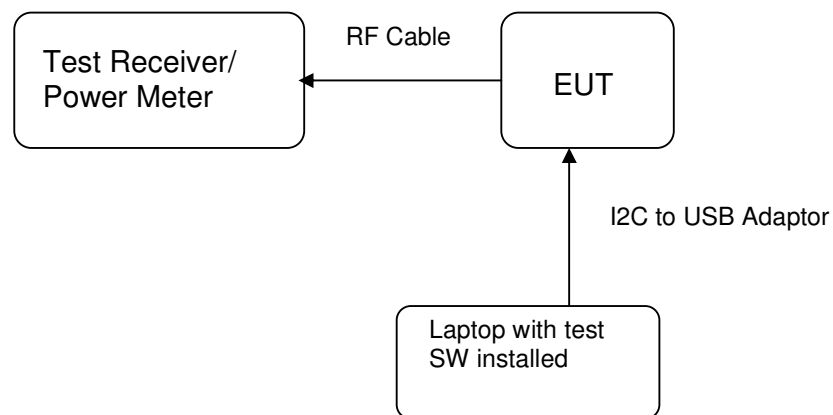

Diagram of Measurement Equipment Configuration for Conducted Transmitter Measurement



5. Test Results

5.1 Transmitter Requirement & Test Suites

5.1.1 99% Bandwidth

RESULT:**Passed**

Test standard : LP0002(2016): 3.10.1, (5)
FCC Part 15.247(a)(2), RSS-247 5.2(1)
Basic standard : ANSI C63.10:2013, KDB558074
Kind of test site : Shielded room

Test setup

Test Channel : Low/ Middle/ High
Operation Mode : A

Ambient temperature : 22-26°C
Relative humidity : 55-65%
Atmospheric pressure : 100-103 kPa

Table 7: Test result of 99% Bandwidth (802.11b)

Channel	Channel Frequency (MHz)	99% Bandwidth (MHz)
Low Channel	2412	14.023
Mid Channel	2437	14.066
High Channel	2462	14.066

Table 8: Test result of 99% Bandwidth (802.11g)

Channel	Channel Frequency (MHz)	99% Bandwidth (MHz)
Low Channel	2412	16.931
Mid Channel	2437	23.878
High Channel	2462	16.975

Table 9: Test result of 99% Bandwidth (802.11n HT20)

Channel	Channel Frequency (MHz)	99% Bandwidth (MHz)
Low Channel	2412	18.017
Mid Channel	2437	28.615
High Channel	2462	17.973

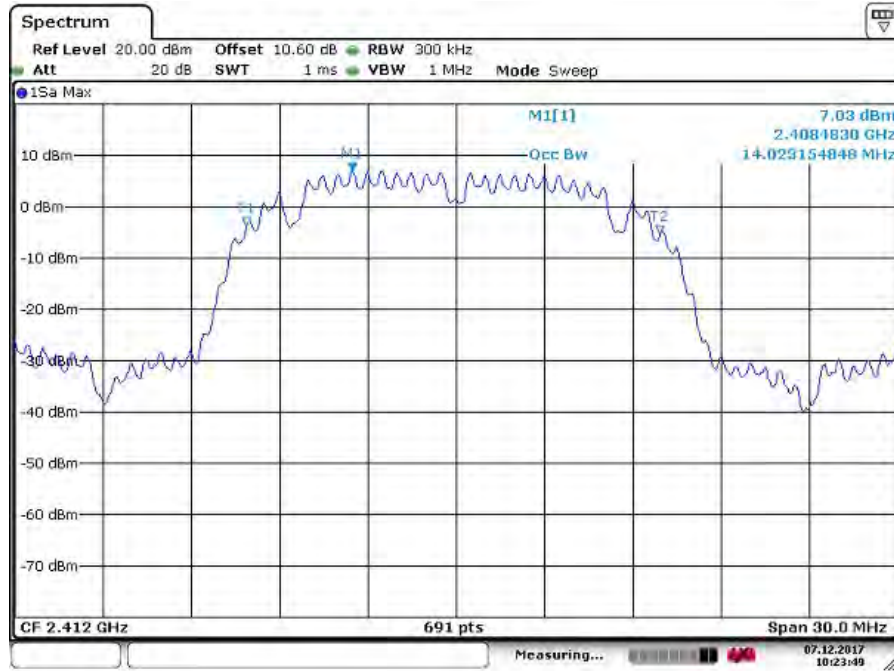
Test Plot of 99% Bandwidth (802.11b)
Low Channel

Date: 7.DEC 2017 10:23:49

Middle Channel



Date: 7.DEC 2017 10:25:39

High Channel

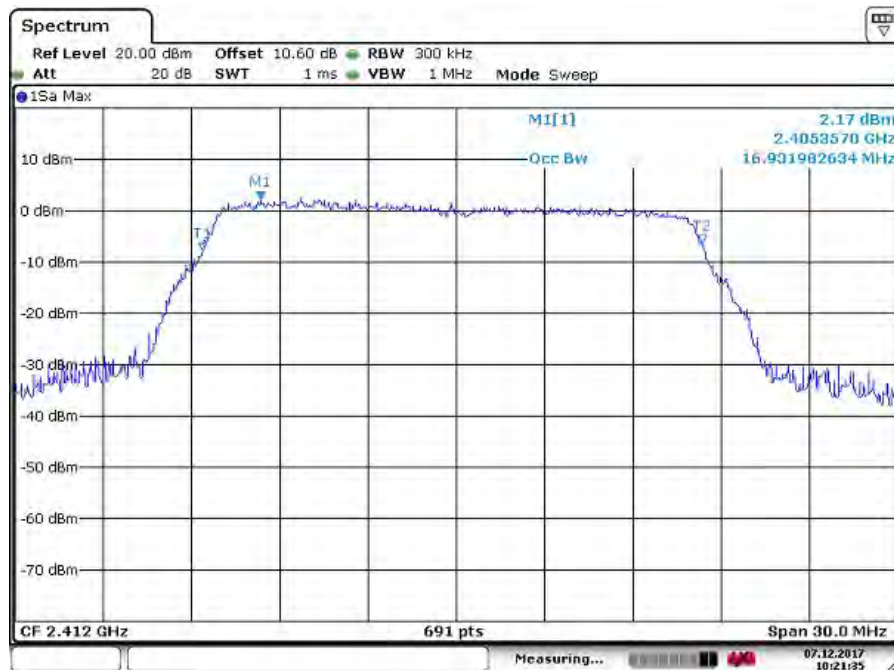

Date: 7 DEC 2017 10:31:35

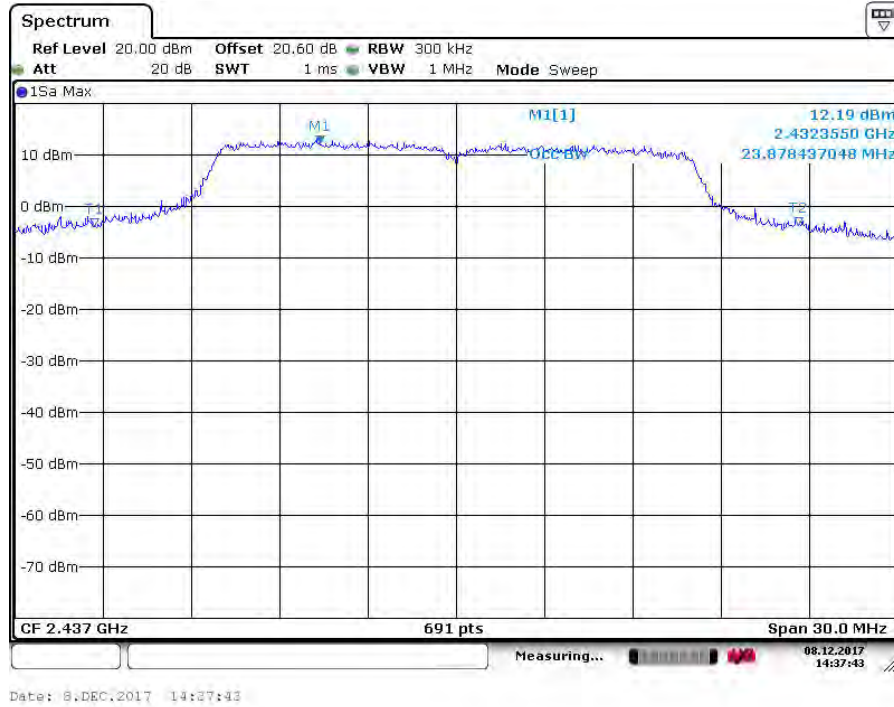
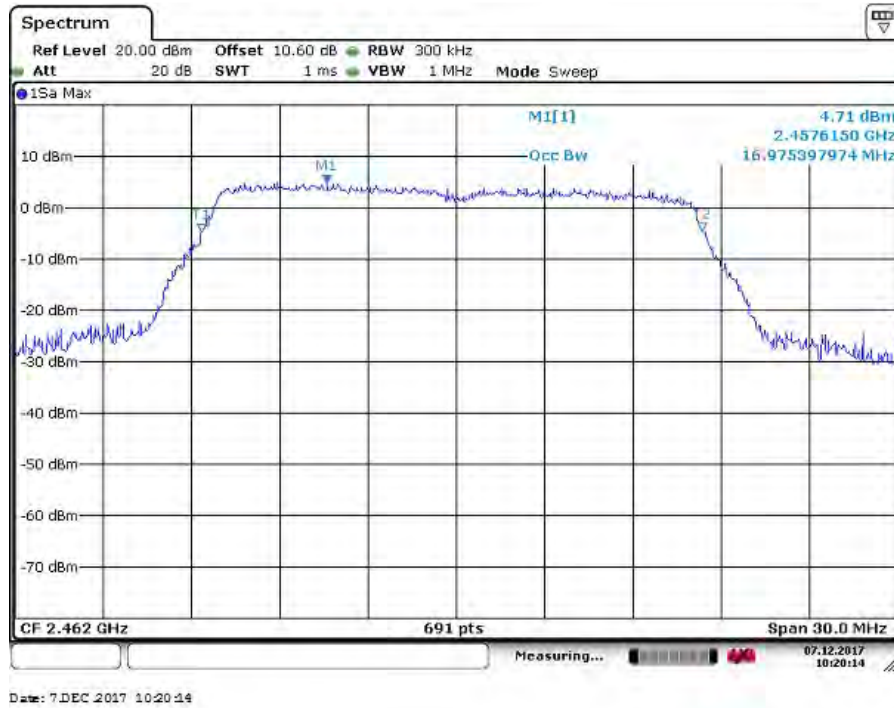
Test Plot of 99% Bandwidth (802.11g)
Low Channel

Date: 7 DEC 2017 10:21:35

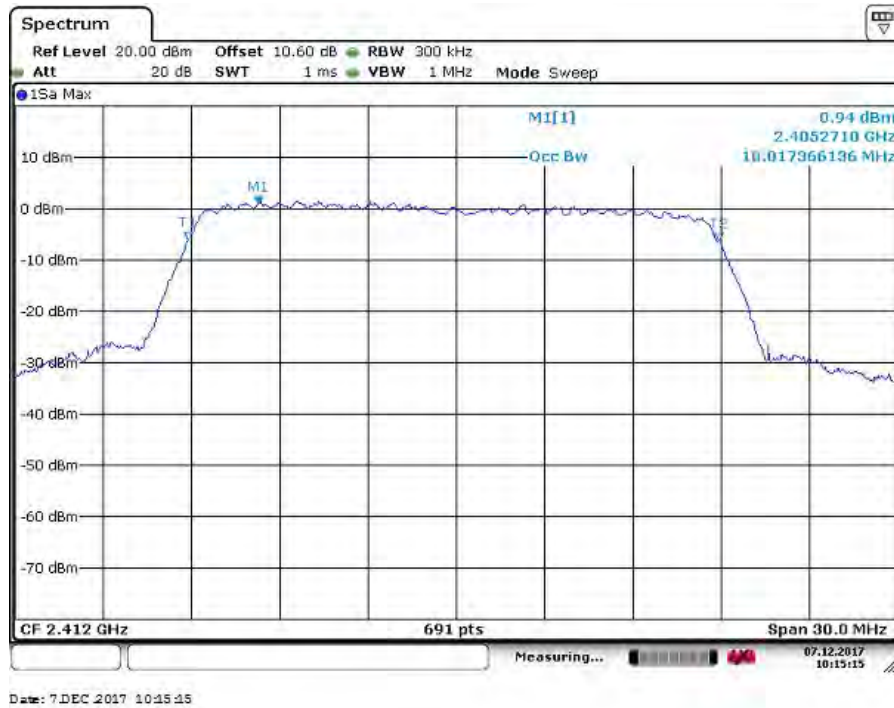
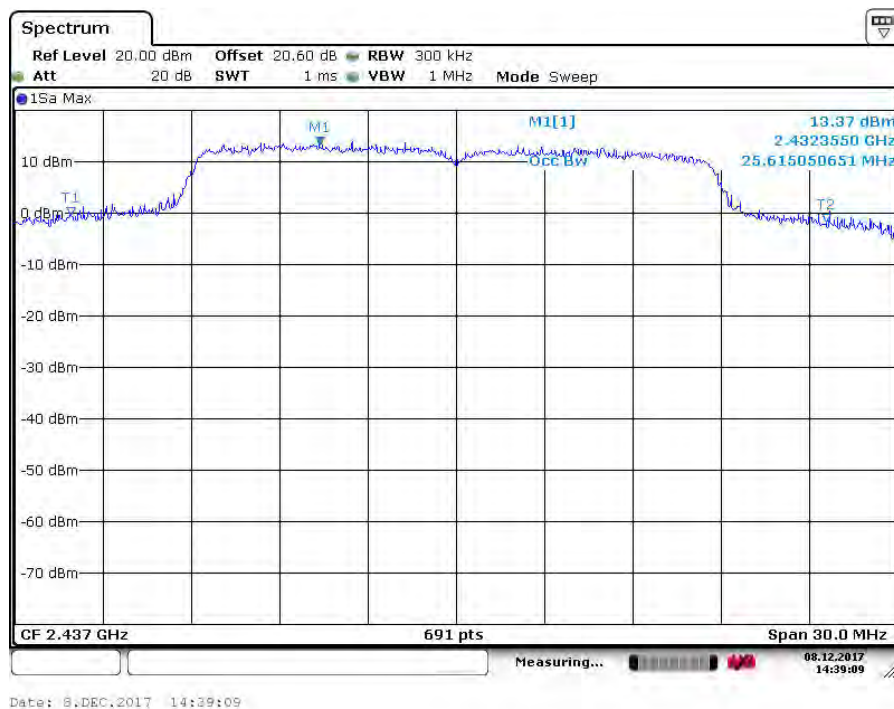
Middle Channel

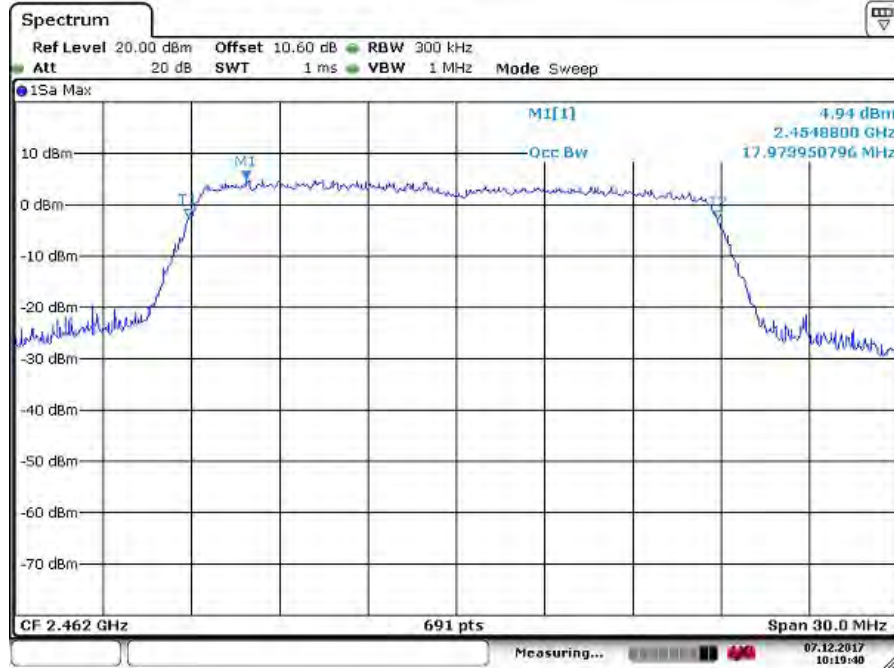
High Channel

Test Plot of 99% Bandwidth (802.11n HT20)
Low Channel

Middle Channel

High Channel

Date: 7 DEC 2017 10:19:41

5.1.2 Spurious Emission

RESULT:**Passed**

Test standard	:	FCC part 15.247(d), FCC 15.205, FCC 15.209, RSS-247 5.5 and RSS-Gen 8.9 LP0002(2016): 3.10.1, (5)
Basic standard	:	ANSI C63.10: 2009
Limits	:	Radiated emissions which fall in the restricted bands, as defined in FCC 15.205(a) and RSS-Gen i4, 8.9 (Table 6), must comply with the radiated emission limits specified in FCC 15.209(a) and RSS-Gen i4, 8.9 (Table 4 and 5). Radiated emissions which fall in the restricted bands, as defined in LP0002(2016): 2.7 , must comply with the radiated emission limits specified in LP0002(2016): 2.8 Emission radiated outside the specified frequency bands must comply with the radiated emission limits specified in FCC 15.209(a), RSS-Gen i4, 8.9 (Table 4 and 5). Emission radiated outside the specified frequency bands must comply with the radiated emission limits specified in LP0002(2016): 2.8
Kind of test site	:	3m Semi-Anechoic Chamber

Test setup

Test Channel	:	Low/ Middle/ High
Operation mode	:	A, B

Remark: Testing was carried out within frequency range 30MHz to the tenth harmonic.

For details refer to Appendix D.

The Radiated Emissions testing was performed in the X, Y and Z axis orientation. The X Axis orientation is the worst-case and recorded in this test report. Due to the small size of the product and that there are no inductive components of significant size, 9kHz to 30MHz frequency range is not tested based on technical judgment.

6. Photographs of the Test Set-Up

Photograph 1: Set-up for Spurious Emissions (Front View)- RFA-02-5-C7H1-ANT

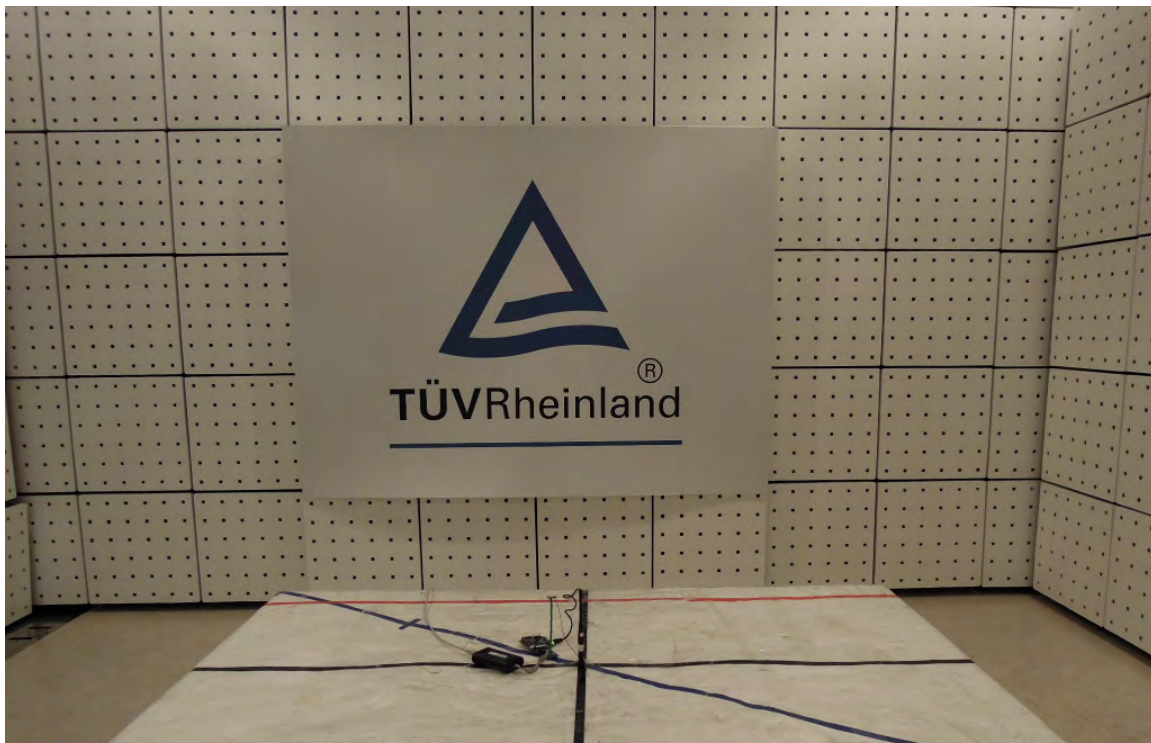

Photograph 2: Set-up for Spurious Emissions (Back View 1)- RFA-02-5-C7H1-ANT

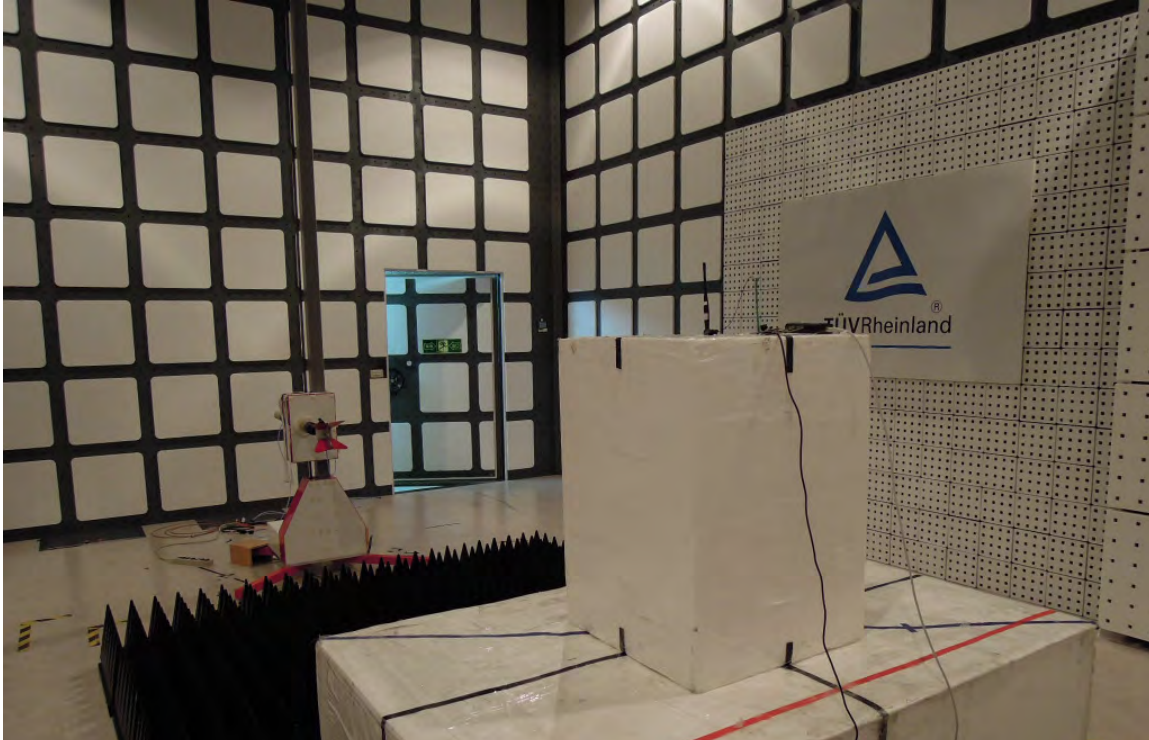

Photograph 3: Set-up for Spurious Emissions (Back View 2)- RFA-02-5-C7H1-ANT

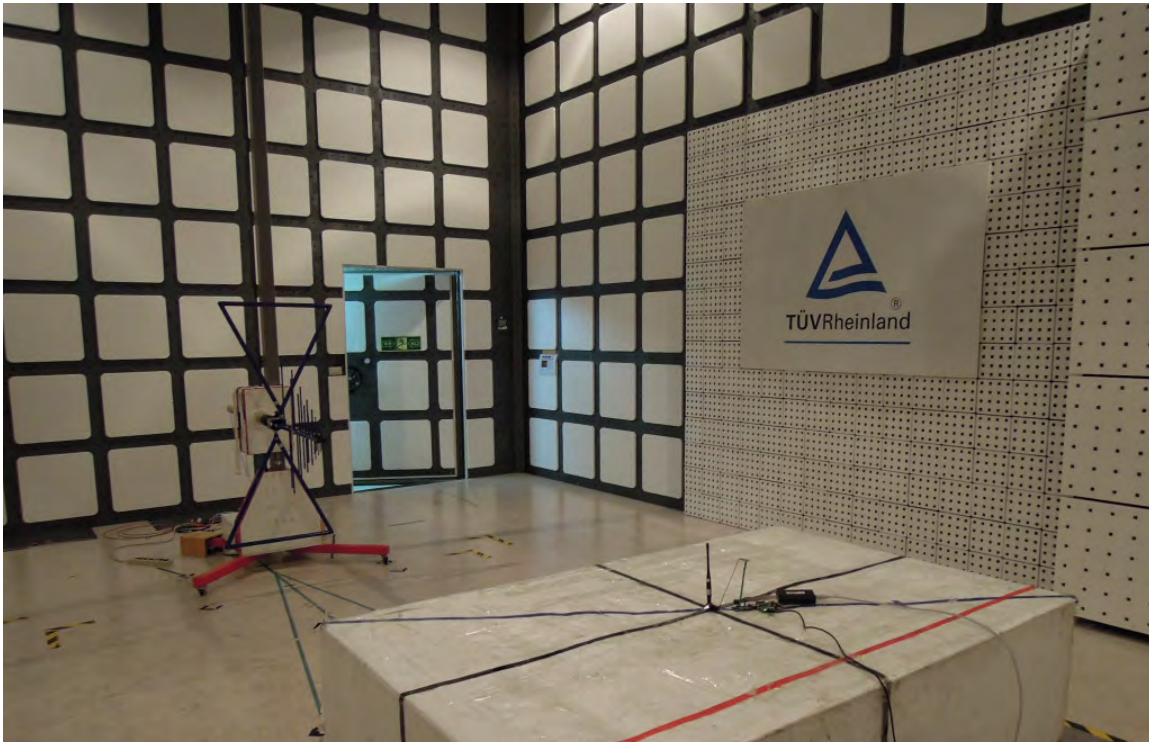

Photograph 4: Set-up for Spurious Emissions (Back View 3)- RFA-02-5-C7H1-ANT

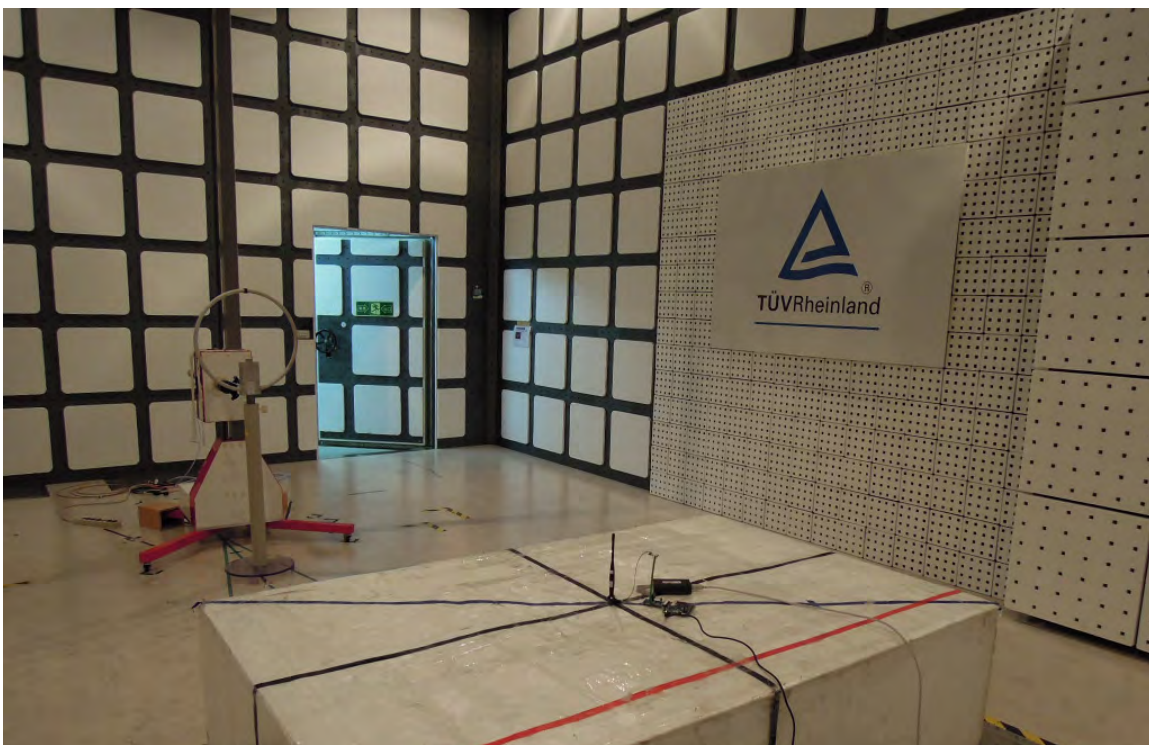

Photograph 5: Set-up for Spurious Emissions (Front View)- RFMTA331215IMAB701-ANT

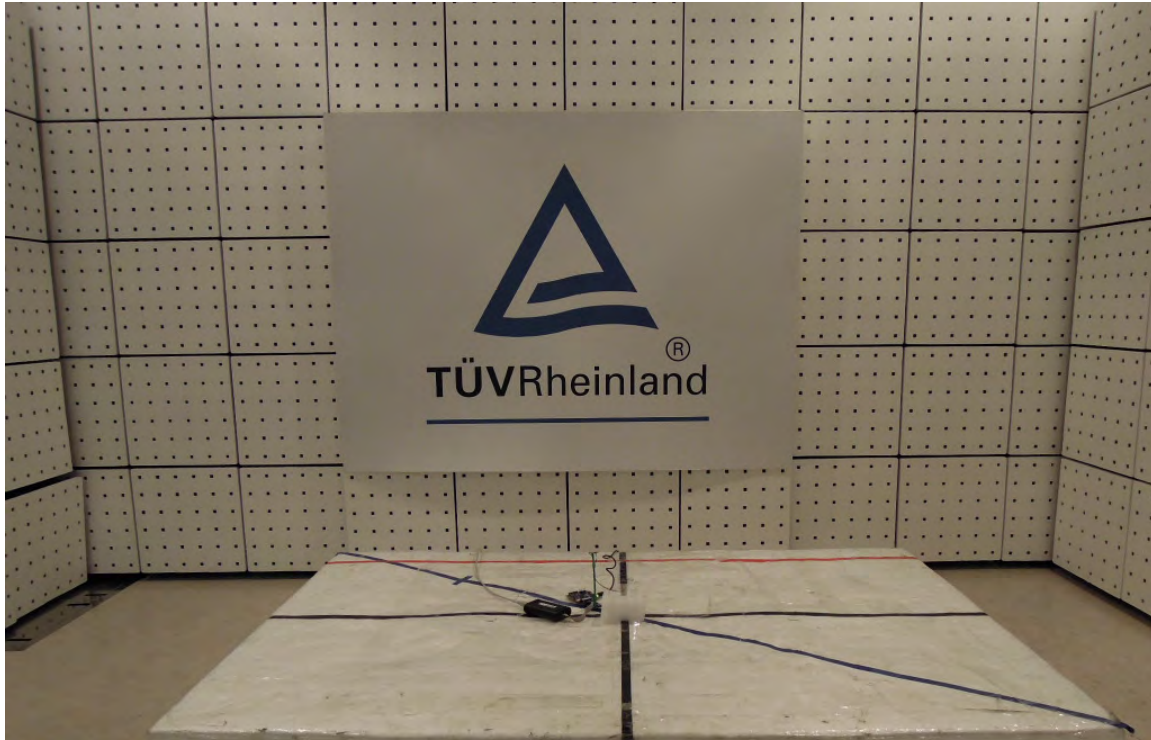

Photograph 6: Set-up for Spurious Emissions (Back View 1)- RFMTA331215IMAB701-ANT

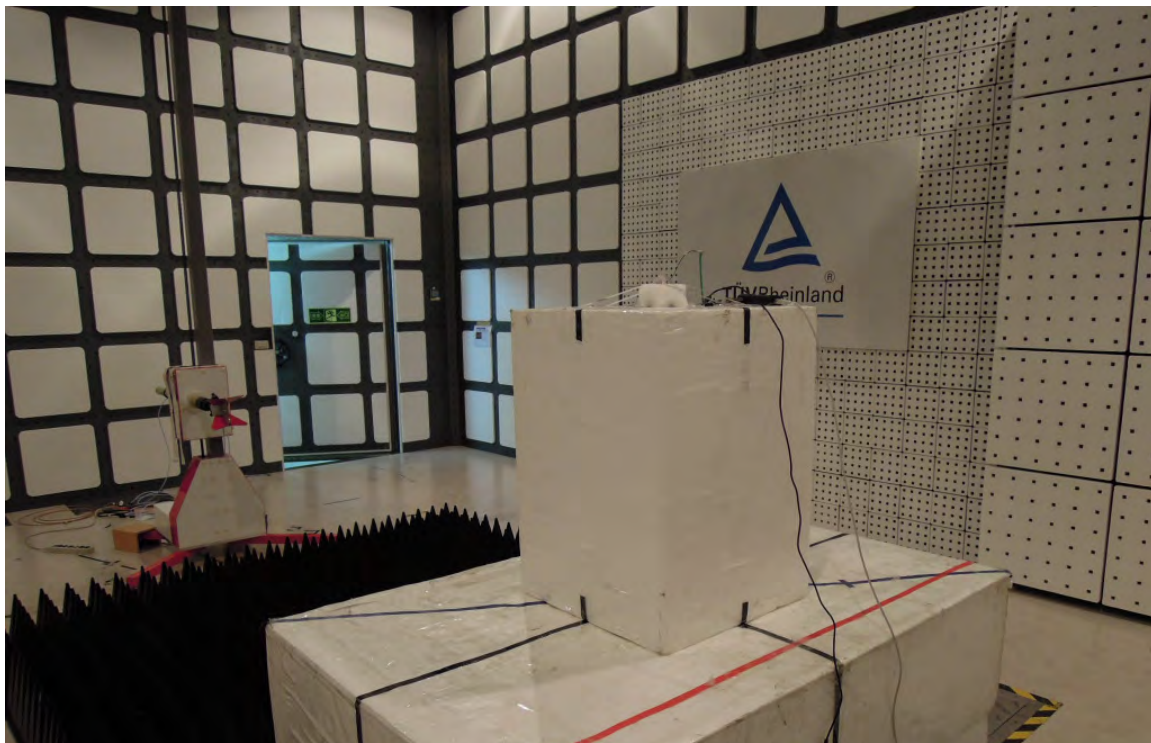

Photograph 7: Set-up for Spurious Emissions (Back View 2)- RFMTA331215IMAB701-ANT

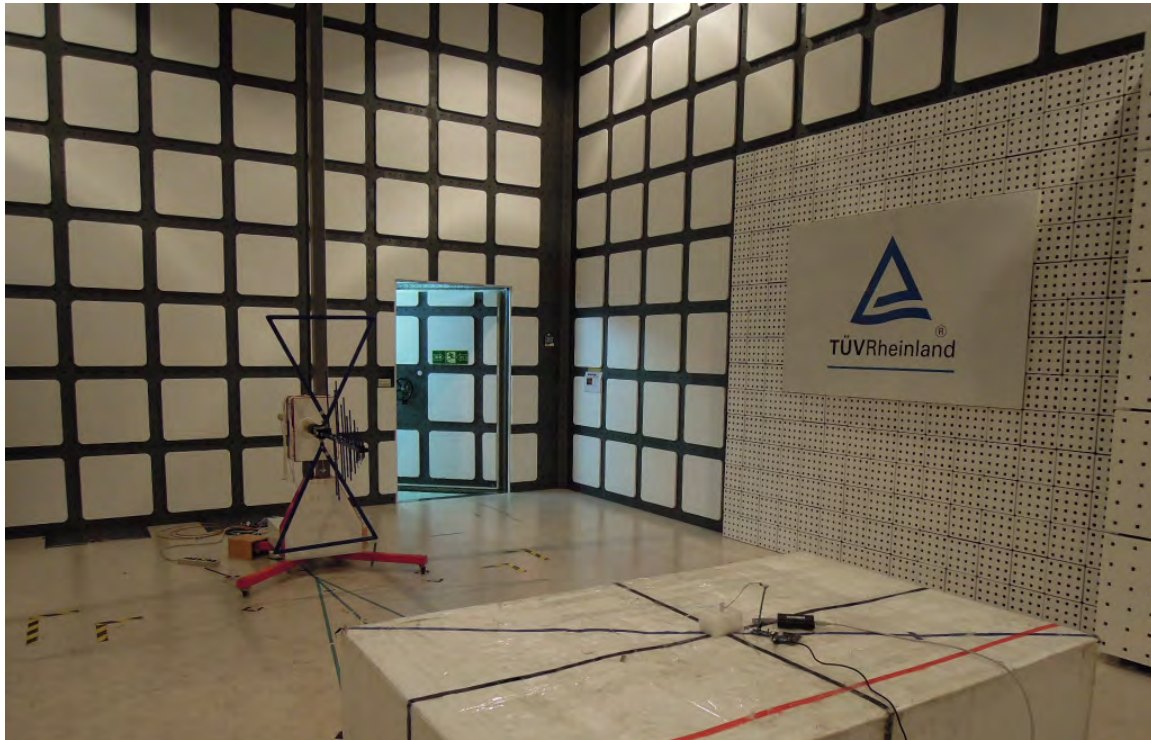

Photograph 8: Set-up for Spurious Emissions (Back View 3)- RFMTA331215IMAB701-ANT

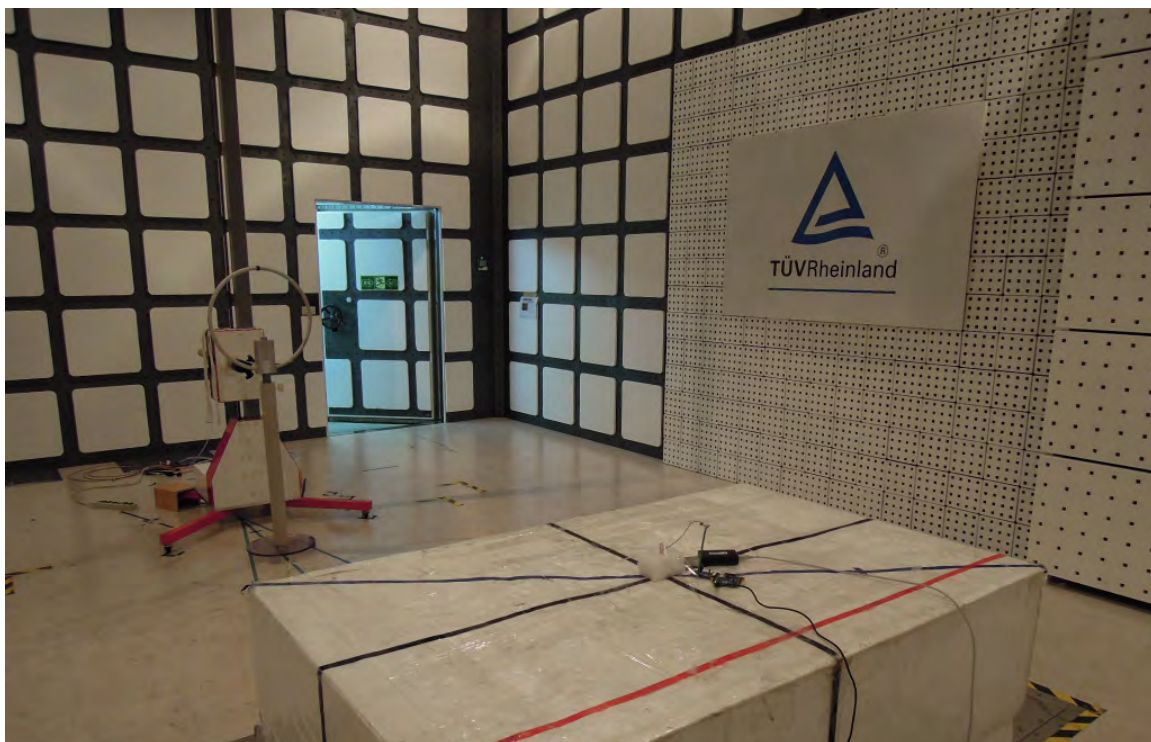

Photograph 9: Set-up for Spurious Emissions (Front View)- RFPCA381013IMAB701-ANT

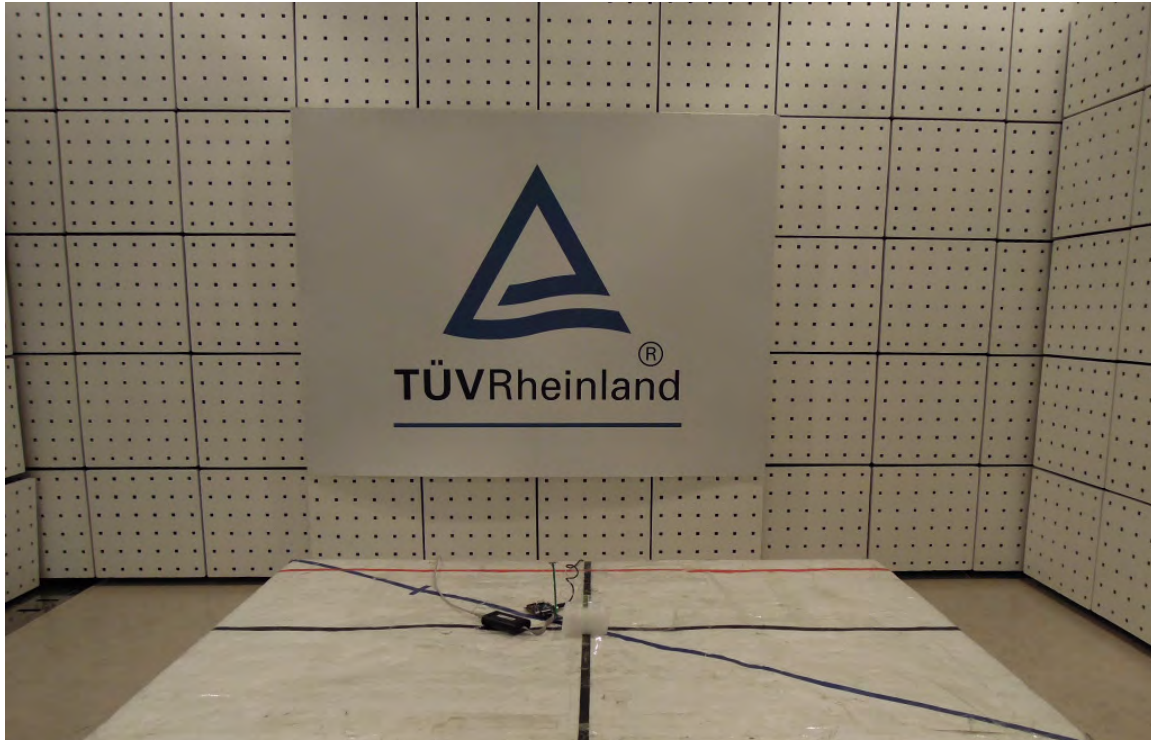

Photograph 10: Set-up for Spurious Emissions (Back View 1)- RFPCA381013IMAB701-ANT

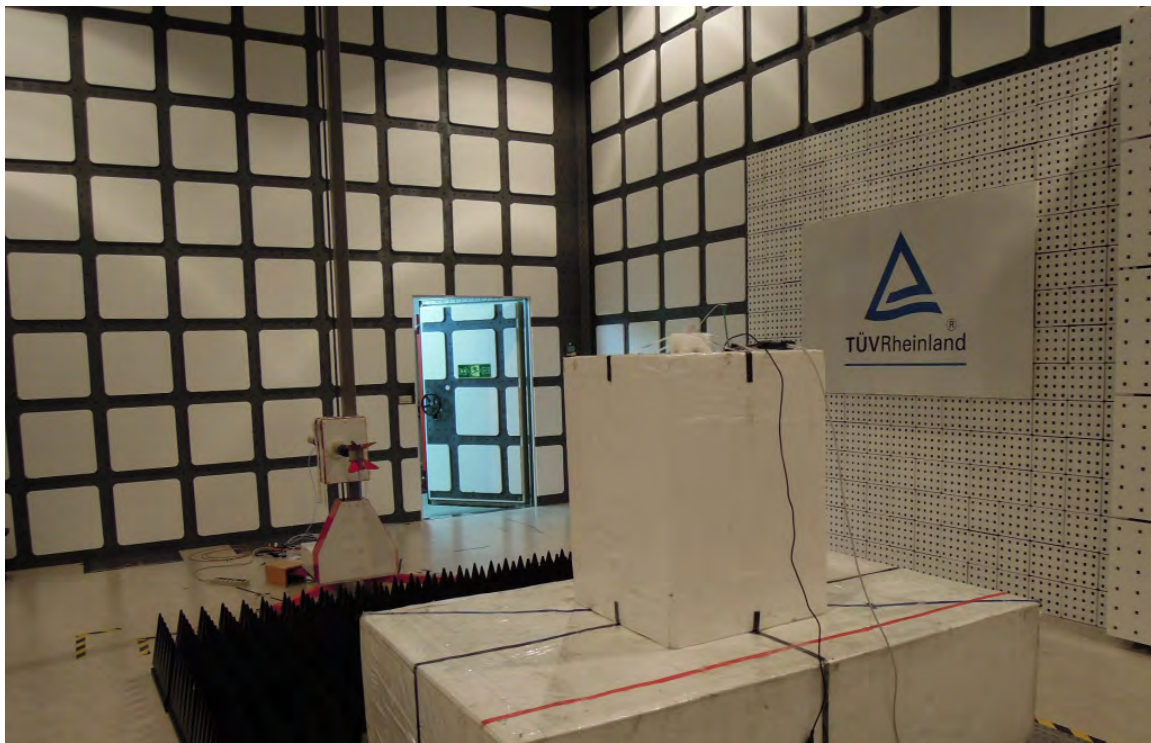

Photograph 11: Set-up for Spurious Emissions (Back View 2)- RFPCA381013IMAB701-ANT

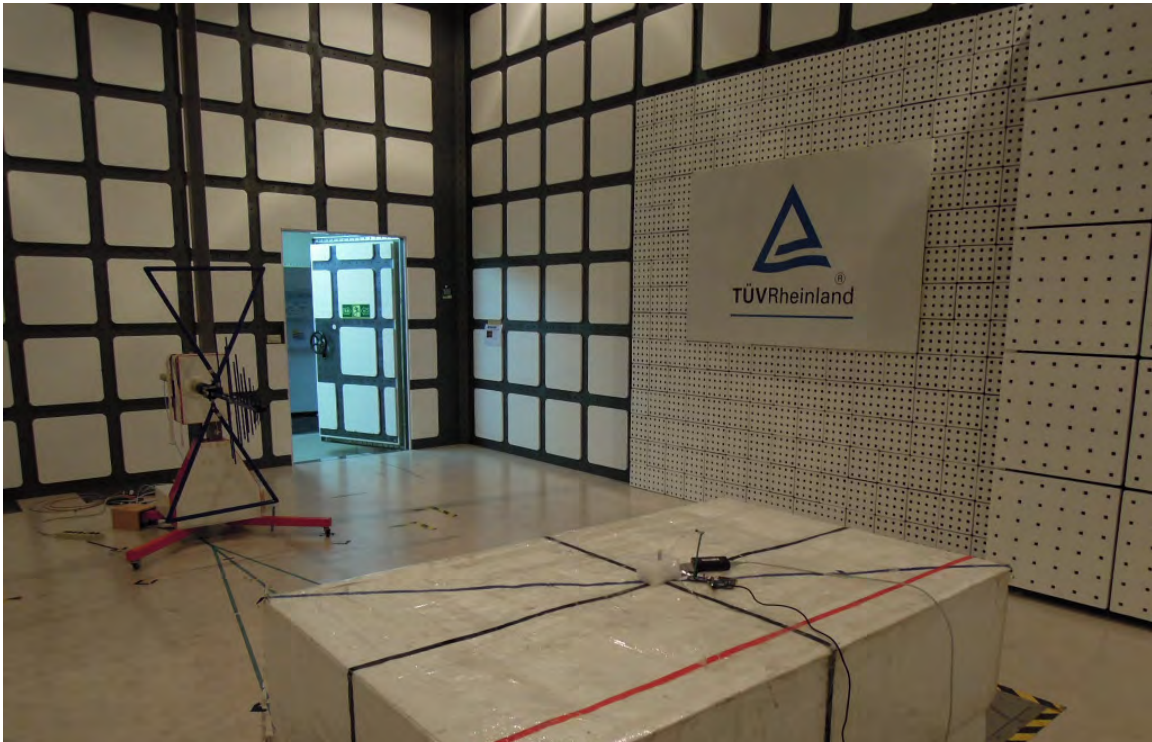

Photograph 12: Set-up for Spurious Emissions (Back View 3)- RFPCA381013IMAB701-ANT

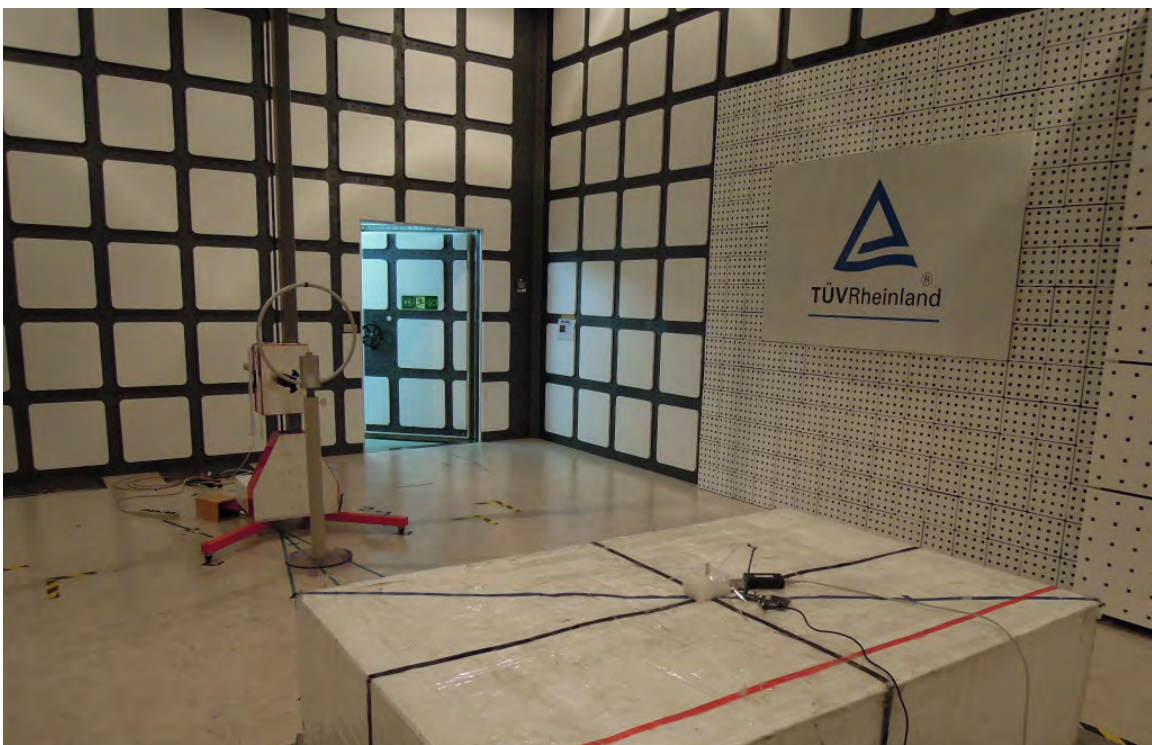

Photograph 13: Set-up for Spurious Emissions (Front View)- RFDPA870920IMLB301-ANT

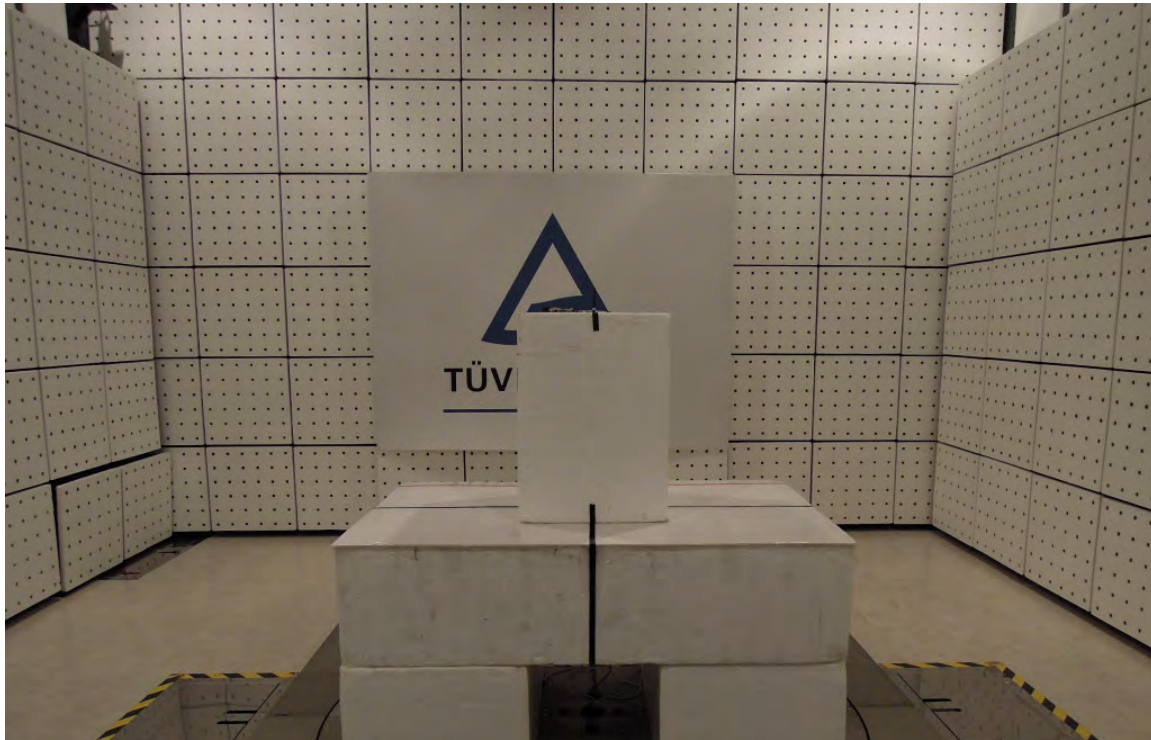

Photograph 14: Set-up for Spurious Emissions (Back View)- RFDPA870920IMLB301-ANT

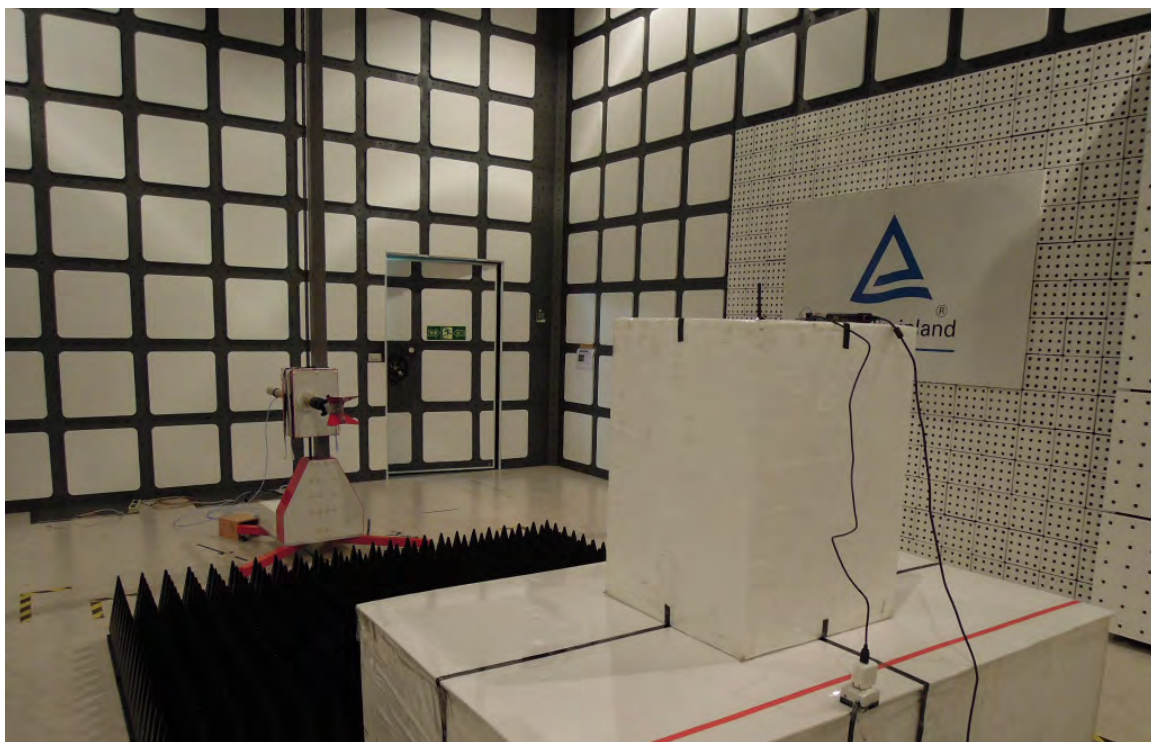

Photograph 15: Set-up for Spurious Emissions (Front View)- RFA-02-3-C5H1 -ANT

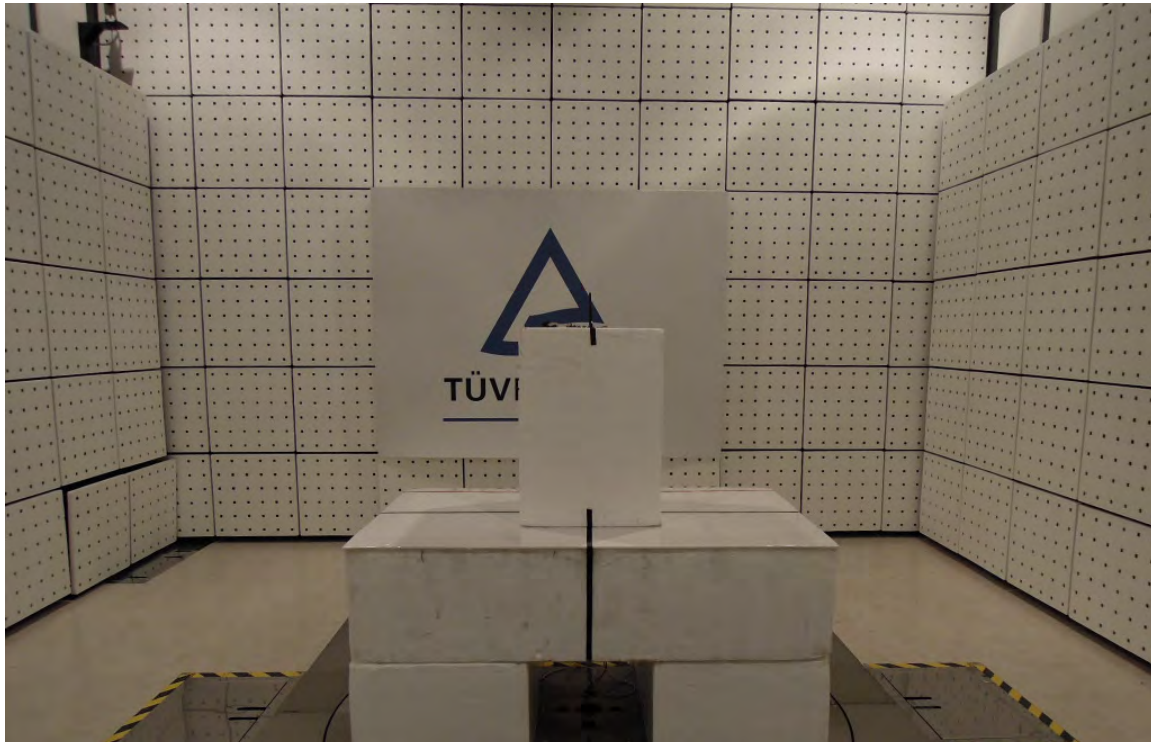

Photograph 16: Set-up for Spurious Emissions (Back View)- RFA-02-3-C5H1 -ANT

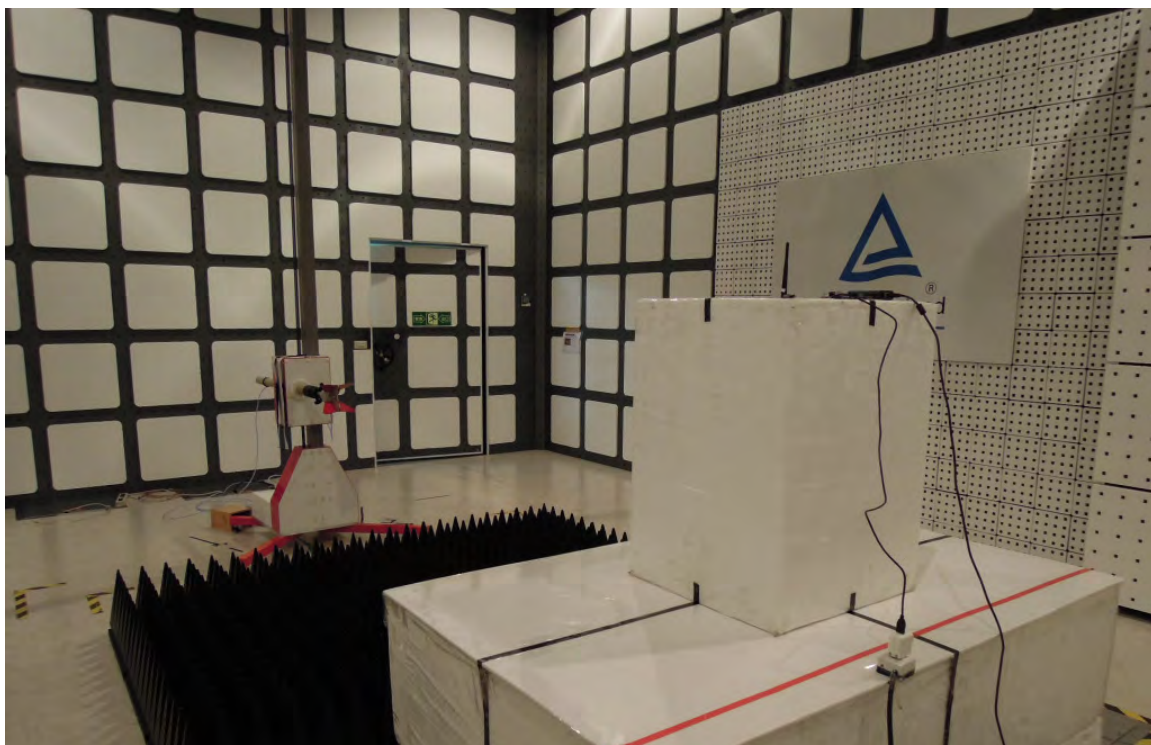

Photograph 17: Set-up for Spurious Emissions (Front View)- 14615300100 -ANT



Photograph 18: Set-up for Spurious Emissions (Back View)- 14615300100 -ANT

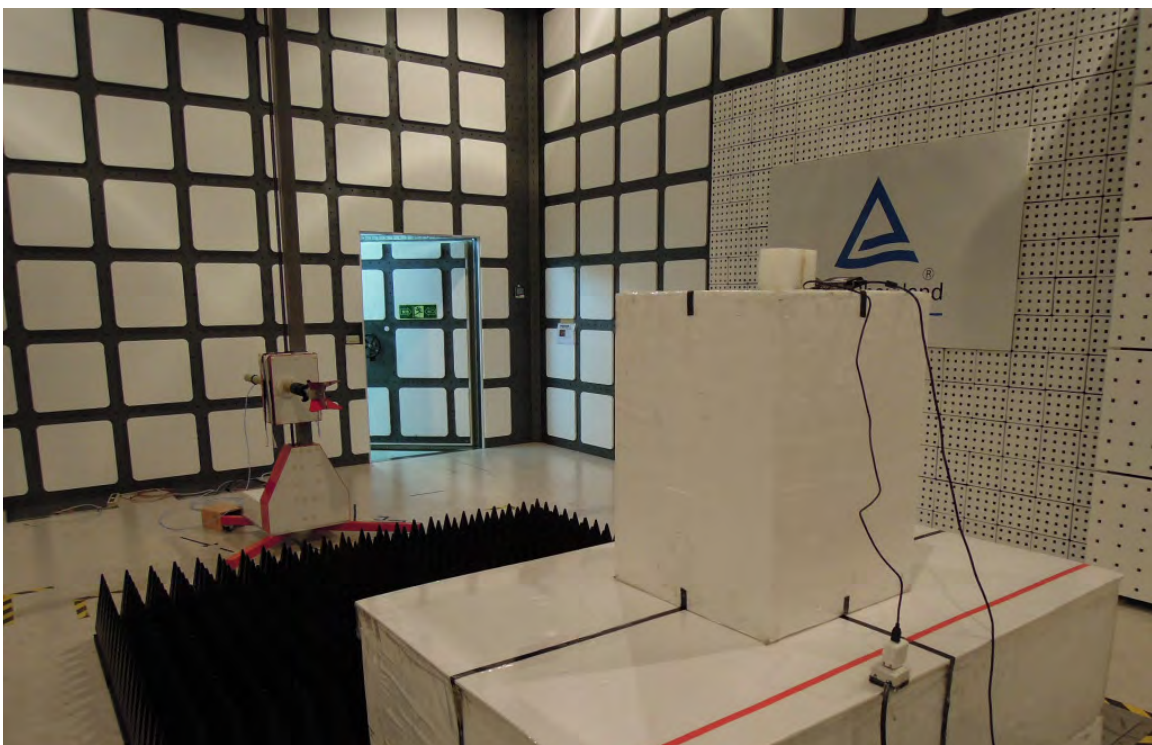

Photograph 19: Set-up for Spurious Emissions (Front View)- ACC-RN-SMA-S-DS -ANT



Photograph 20: Set-up for Spurious Emissions (Back View)- ACC-RN-SMA-S-DS -ANT

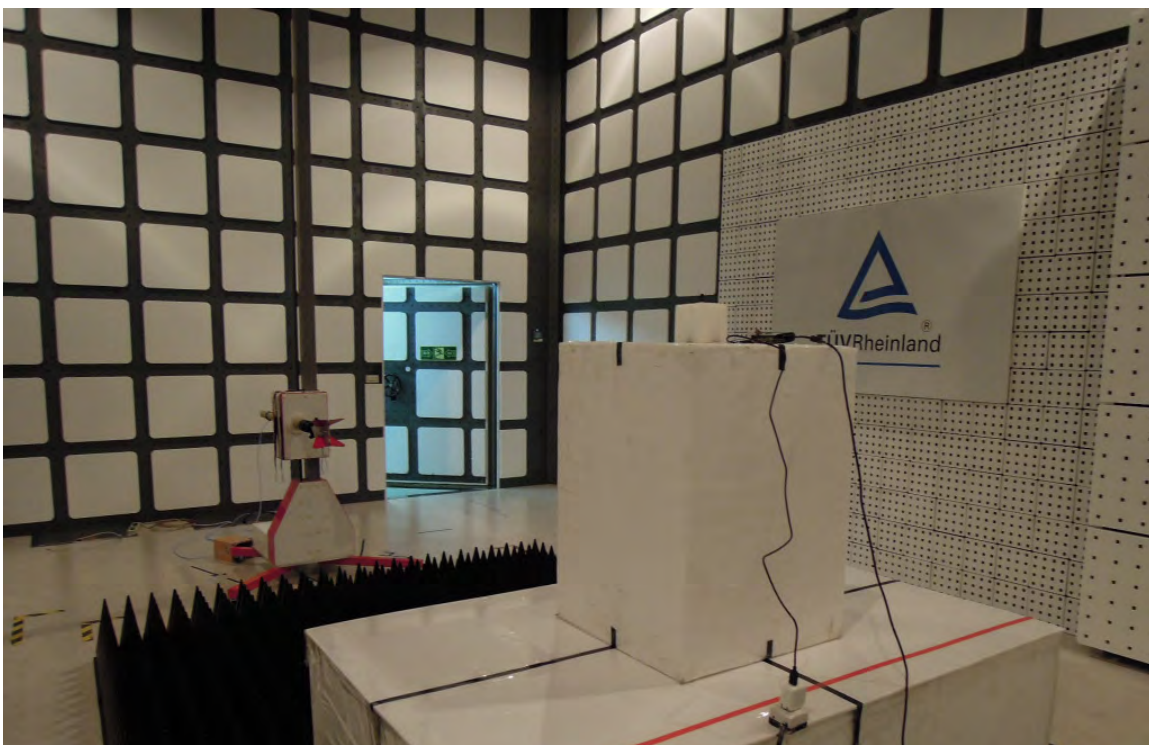

7. List of Tables

Table 1: Applied Standard and Test Levels	4
Table 2: List of Test and Measurement Equipment	6
Table 3: Emission Measurement Uncertainty.....	7
Table 4: Basic Information of EUT	8
Table 5: Technical Specification of EUT	9
Table 6: External Antenna list.....	10
Table 7: Test result of 99% Bandwidth (802.11b)	16
Table 8: Test result of 99% Bandwidth (802.11g)	16
Table 9: Test result of 99% Bandwidth (802.11n HT20)	16

8. List of Photographs

Photograph 1: Set-up for Spurious Emissions (Front View)- RFA-02-5-C7H1-ANT.....	23
Photograph 2: Set-up for Spurious Emissions (Back View 1)- RFA-02-5-C7H1-ANT	24
Photograph 3: Set-up for Spurious Emissions (Back View 2)- RFA-02-5-C7H1-ANT	25
Photograph 4: Set-up for Spurious Emissions (Back View 3)- RFA-02-5-C7H1-ANT	25
Photograph 5: Set-up for Spurious Emissions (Front View)- RFMTA331215IMAB701-ANT	26
Photograph 6: Set-up for Spurious Emissions (Back View 1)- RFMTA331215IMAB701-ANT	26
Photograph 7: Set-up for Spurious Emissions (Back View 2)- RFMTA331215IMAB701-ANT	27
Photograph 8: Set-up for Spurious Emissions (Back View 3)- RFMTA331215IMAB701-ANT	27
Photograph 9: Set-up for Spurious Emissions (Front View)- RFPCA381013IMAB701-ANT.....	28
Photograph 10: Set-up for Spurious Emissions (Back View 1)- RFPCA381013IMAB701-ANT	28
Photograph 11: Set-up for Spurious Emissions (Back View 2)- RFPCA381013IMAB701-ANT	29
Photograph 12: Set-up for Spurious Emissions (Back View 3)- RFPCA381013IMAB701-ANT	29
Photograph 13: Set-up for Spurious Emissions (Front View)- RFDPA870920IMLB301-ANT	30
Photograph 14: Set-up for Spurious Emissions (Back View)- RFDPA870920IMLB301-ANT	30
Photograph 15: Set-up for Spurious Emissions (Front View)- RFA-02-3-C5H1 -ANT	31
Photograph 16: Set-up for Spurious Emissions (Back View)- RFA-02-3-C5H1 -ANT	31
Photograph 17: Set-up for Spurious Emissions (Front View)- 14615300100 -ANT.....	32
Photograph 18: Set-up for Spurious Emissions (Back View)- 14615300100 -ANT	32
Photograph 19: Set-up for Spurious Emissions (Front View)- ACC-RN-SMA-S-DS -ANT	33
Photograph 20: Set-up for Spurious Emissions (Back View)- ACC-RN-SMA-S-DS -ANT	33