



PHOENIX
TESTLAB

Königswinkel 10
32825 Blomberg, Germany
Phone: +49 (0) 52 35 / 95 00-0
Fax: +49 (0) 52 35 / 95 00-10
office@phoenix-testlab.de
www.phoenix-testlab.de

Test Report

Report Number:

F170923E1 3rd version

Equipment under Test (EUT):

B&R radio board with 13.56 MHz NFC and onboard BTLE+WiFi Module

RFM-1-BTWNF

Applicant:

B&R Industrial Automation GmbH

Manufacturer:

B&R Industrial Automation GmbH



Deutsche
Akkreditierungsstelle
D-PL-17186-01-01
D-PL-17186-01-02
D-PL-17186-01-03



References

- [1] **ANSI C63.10: 2013** American National Standard of Procedures for Compliance Testing of Unlicensed Wireless Devices
- [2] **FCC CFR 47 Part 15** Radio Frequency Devices
- [3] **RSS-210 Issue 9 (August 2016)** Licence-exempt Radio Apparatus (All Frequency Bands): Category I Equipment
- [4] **RSS-Gen Issue 4 (November 2014)** General Requirements for Compliance of Radio Apparatus

Test result

The requirements of the tests performed as shown in the overview (clause 4) **were fulfilled** by the equipment under test.

The complete test results are presented in the following.

Test engineer:	Michael DINTER		09.05.2018
	Name	Signature	Date
Authorized reviewer:	Bernd STEINER		09.05.2018
	Name	Signature	Date

This test report is only valid in its original form.

Any reproduction of its contents in extracts without written permission of the accredited test laboratory PHOENIX TESTLAB GmbH is prohibited.

The test results herein refer only to the tested sample. PHOENIX TESTLAB GmbH is not responsible for any generalisations or conclusions drawn from these test results concerning further samples. Any modification of the tested samples is prohibited and leads to the invalidity of this test report. Each page necessarily contains the PHOENIX TESTLAB Logo and the TEST REPORT NUMBER.

Contents:	Page
1 Identification	4
1.1 Applicant	4
1.2 Manufacturer	4
1.3 Test Laboratory	4
1.4 EUT (Equipment Under Test)	5
1.5 Technical data of equipment.....	5
1.6 Ancillary equipment used for test.....	6
1.7 Dates.....	6
2 Operational states and test setup.....	6
3 Additional information.....	7
4 Overview	7
5 Results	8
5.1 Conducted emission measurement on ac mains (150 kHz to 30 MHz)	8
5.1.1 Method of measurement conducted emission.....	8
5.1.2 Test result (conducted emission measurement on AC mains).....	9
5.2 Radiated emissions	11
5.2.1 Method of measurement (radiated emissions)	11
5.2.2 Results preliminary measurement 9 kHz to 1 GHz.....	18
5.2.3 Result final measurement from 9 kHz to 30 MHz	20
5.2.4 Result final measurement from 30 MHz to 1 GHz	21
5.3 99 % bandwidth.....	23
5.3.1 Method of measurement.....	23
5.3.2 Test results	24
6 Test equipment.....	25
7 Report history.....	26
8 List of annexes	26

1 Identification

1.1 Applicant

Name:	B&R Industrial Automation GmbH
Address:	B&R Straße 1 5142 Eggelsberg
Country:	Austria
Name for contact purposes:	Bernhard Falch
Phone:	+43 7748 6586 1323
Fax:	+43 7748 6586 26
eMail Address:	Bernhard.falch@br-automation.com
Applicant represented during the test by the following person:	-

1.2 Manufacturer

Name:	B&R Industrial Automation GmbH
Address:	B&R Straße 1 5142 Eggelsberg
Country:	Austria
Name for contact purposes:	Bernhard Falch
Phone:	+43 7748 6586 1323
Fax:	+43 7748 6586 26
eMail Address:	Bernhard.falch@br-automation.com
Manufacturer represented during the test by the following person:	-

1.3 Test Laboratory

The tests were carried out at:

PHOENIX TESTLAB GmbH
Königswinkel 10
32825 Blomberg
Germany

accredited by Deutsche Akkreditierungsstelle GmbH (DAkkS) in compliance with DIN EN ISO/IEC 17025 under Reg. No. D-PL-17186-01-02, FCC Test Firm Accreditation with the registration number 469623, designation number DE0004 and Industry Canada Test site registration SITE# IC3469A-1.

1.4 EUT (Equipment Under Test)

Test object: *	B&R radio board with 13.56 MHz NFC and onboard BTLE+WiFi Module
Type / PMN: *	RFM-1-BTWNF
FCC ID: *	2ADFV-RFM-1-BTWNF
IC Certification Number: *	12444A-RFM1BTWNF
Serial number: *	Engineering sample
PCB identifier: *	WIFI-BT-NFC
MAC Address:*	5C-F3-70-41-6D-92
HVIN (Hardware Version Identification Number): *	RFM-1-BTWNF
FVIN (Firmware Version Identification Number): *	v1.0
Lowest internal frequency: *	13.56 MHz of the relevant NFC part
Highest internal frequency: *	27.12 MHz OSC of the relevant NFC part

*: Declared by the applicant. The EUT was not labeled during the tests.

1.5 Technical data of equipment

Channel 1	RX:	13.56 MHz	TX:	13.56 MHz		
Rated RF output power: *	<20 mW					
Antenna type: *	SMD wire antenna with 13.75 mm ²					
Number of channels: *	1					
Antenna connector: *	None					
Modulation: *	ON/OFF Keying (OOKà 100% square wave amplitude modulation)					
Data rate: *	1.212 kbit/s					
Supply Voltage: *	U _{Nom} =	5.0 V DC	U _{Min} =	4.75V DC	U _{Max} =	5.25 V DC
Temperature range: *	-0 °C to +75 °C					
Ancillary used for test:	5 V DC USB (EUT was supplied by a Laptop via USB and the Laptop via 120 V AC 60 Hz AC mains) AC Adapter Lenovo Model: 42T4416					

*: declared by the applicant.

Ports / Connectors			
Identification	Connector		Length during test
	EUT	Ancillary	
System connector (DC and data lines USB used)	Mini plug	USB	2.5 m
-	-	-	-

1.6 Ancillary equipment used for test

TAG Type: ISO14443A/MIFARE (56 Bit).
Laptop: Lenovo ThinkPad X201T
AC Adapter Lenovo Model: 42T4416

1.7 Dates

Date of receipt of test sample:	07.07.2017
Start of test:	18.07.2017
End of test:	31.08.2017

2 Operational states and test setup

The EUT is a radio module that incorporates a 13.56 MHz RFID transponder and an additional already FCC/IC certified Bluetooth Low Energy&WiFi Module.

All tests were carried out with an unmodified test sample, which operates in normal mode.

During all tests the EUT was supplied via USB interface from a Laptop and reading a TAG.

The transponder code was shown on the Laptop with software delivered by the applicant.

No spurious emission measurement of the receiver was carried out, because the self-located RFID transmitter transmits continuously.

During all tests the EUT was supplied via 5 V DC USB interface from a Laptop Lenovo ThinkPad X201T with an AC adapter Lenovo Model: 42T4416 supplied by 120 V AC / 60 Hz.

Physical boundaries of the Equipment Under Test

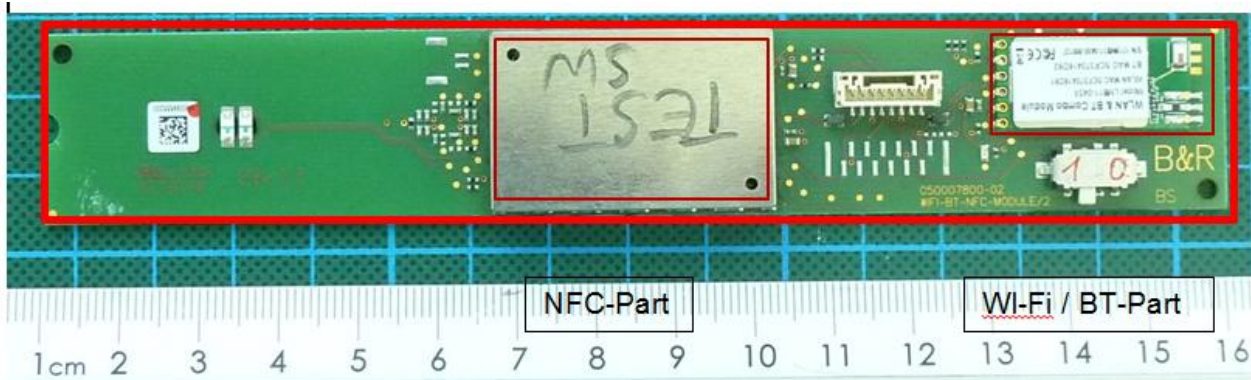

3 Additional information

This test report covers the measurement results of the 13.56 MHz RFID transmitter only - the additional BT/WiFi module has been simply switched off. The simultaneous transmission measurements of the 13.56 MHz RFID and the combo BT/WiFi module are covered by separate test reports.

The EUT was not labeled as required by FCC / IC.

4 Overview

Application	Frequency range [MHz]	FCC 47 CFR Part 15 section [2]	RSS-Gen, Issue 4 [4] and RSS 210, Issue 9 [3]	Status	Refer page
Conducted emissions on supply line	0.15 – 30	15.207	8.8 [4]	Passed	8 et seq.
Radiated emissions	0.009 – 1.000	15.205 15.209	8.9 [4] 4.4 [3]	Passed	11 et seq.
99 % bandwidth	13.56	-	6.6 [4]	-	21 et seq.
Antenna requirement	-	15.203	8.3 [4]	Passed **	-

** : Integrated antenna only, requirement fulfilled.

5 Results

5.1 Conducted emission measurement on ac mains (150 kHz to 30 MHz)

5.1.1 Method of measurement conducted emission

This test will be carried out in a shielded chamber. Table top devices will set up on a non-conducting support with a size of 1 m by 1.5 m and a height of 80 cm above the ground plane. Floor-standing devices will be placed directly on the ground plane. The setup of the Equipment under test will be in accordance to [1].

The frequency range 150 kHz to 30 MHz will be measured with an EMI Receiver set to MAX Hold mode with peak and average detector and a resolution bandwidth of 9 kHz. A scan will be carried out on the phase (or plus pole in case of DC powered devices) of the AC mains network. If levels detected 10 dB below the appropriate limit, this emission will be measured with the average and quasi-peak detector on all lines.

Frequency range	Resolution bandwidth
150 kHz to 30 MHz	9 kHz

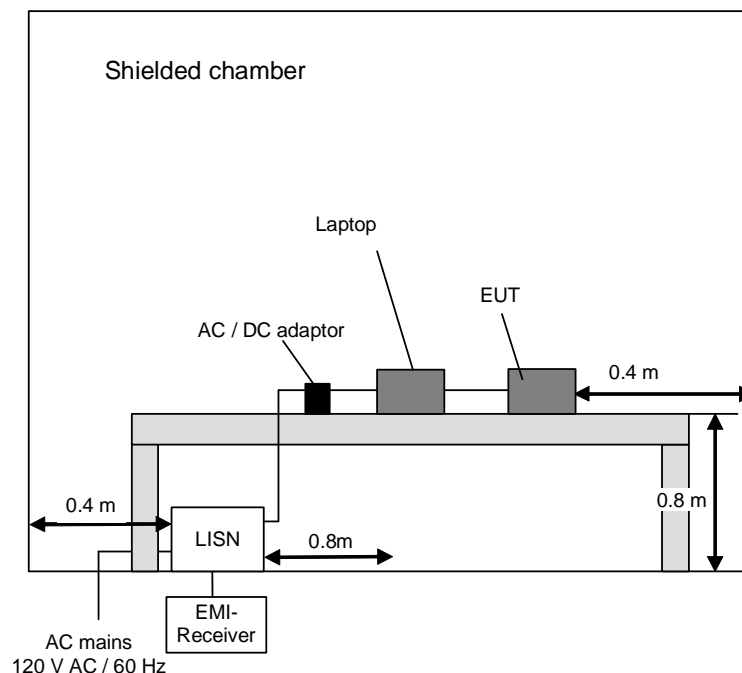

5.1.2 Test result (conducted emission measurement on AC mains)

Ambient temperature:	20 °C	Relative humidity:	45 %
----------------------	-------	--------------------	------

- Position of EUT: The EUT was set-up on a wooden table of a height of 0.8 m.
- Cable guide: The cable of the EUT was fixed on the wooden table. For further information of the cable guide refer to the pictures in annex A of this test report.
- Test record: The test was carried out in normal operation mode of the EUT (reading a TAG). All results are shown in the following.
- Power supply: During this test the EUT was supplied with 5.00 V DC via USB by a laptop Lenovo ThinkPad X201T powered with 120 V AC / 60 Hz AC-mains network.(AC Adapter Lenovo Model: 42T4416)
- Operation states: As described in chapter 2.

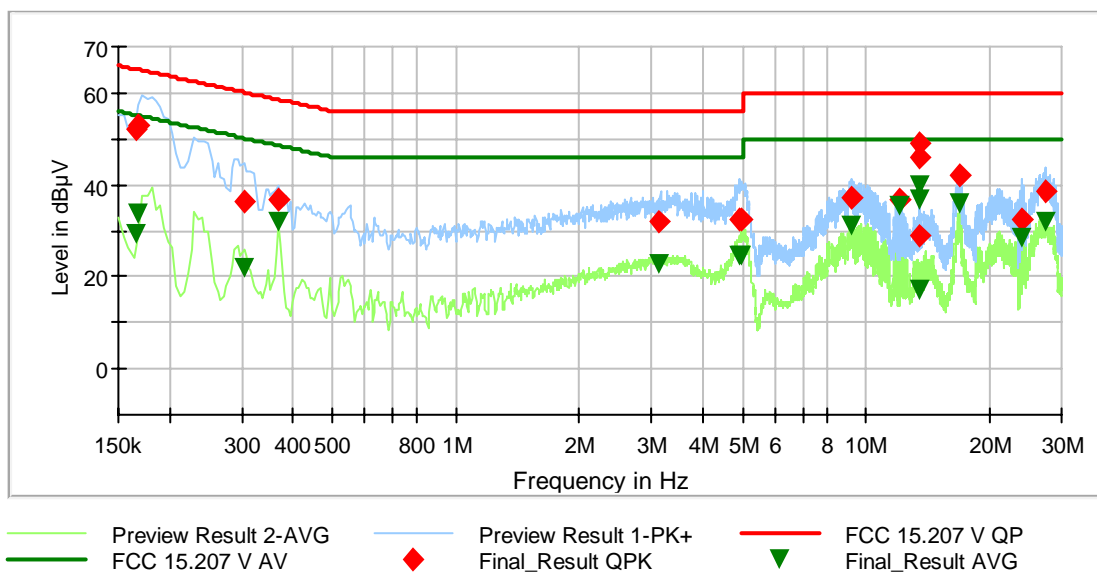

170923vAC209NFCB

Final Result

Frequency (MHz)	QuasiPeak (dBµV)	Average (dBµV)	Limit (dBµV)	Margin (dB)	Meas. Time (ms)	Bandwidth (kHz)	Line	PE	Corr. (dB)
0.165300	---	29.33	55.19	25.87	5000.0	9.000	L1	FLO	9.8
0.165300	52.00	---	65.19	13.20	5000.0	9.000	L1	FLO	9.8
0.168000	52.84	---	65.06	12.22	5000.0	9.000	L1	GND	9.8
0.168000	---	33.85	55.06	21.21	5000.0	9.000	L1	GND	9.8
0.304800	36.54	---	60.11	23.57	5000.0	9.000	L1	GND	9.9
0.304800	---	21.72	50.11	28.39	5000.0	9.000	L1	GND	9.9
0.370500	36.99	---	58.49	21.50	5000.0	9.000	L1	GND	9.9
0.370500	---	31.93	48.49	16.56	5000.0	9.000	L1	GND	9.9
3.141600	31.76	---	56.00	24.24	5000.0	9.000	L1	FLO	10.2
3.141600	---	22.98	46.00	23.02	5000.0	9.000	L1	FLO	10.2
4.887600	32.36	---	56.00	23.64	5000.0	9.000	L1	FLO	10.3
4.887600	---	24.66	46.00	21.34	5000.0	9.000	L1	FLO	10.3
4.933500	32.20	---	56.00	23.80	5000.0	9.000	L1	FLO	10.3
4.933500	---	24.47	46.00	21.53	5000.0	9.000	L1	FLO	10.3
9.175200	---	31.13	50.00	18.87	5000.0	9.000	L1	GND	10.5
9.175200	37.28	---	60.00	22.72	5000.0	9.000	L1	GND	10.5
11.999400	36.73	---	60.00	23.27	5000.0	9.000	N	FLO	10.7
11.999400	---	35.25	50.00	14.75	5000.0	9.000	N	FLO	10.7
13.454700	---	17.23	50.00	32.77	5000.0	9.000	N	FLO	10.8
13.454700	28.98	---	60.00	31.02	5000.0	9.000	N	FLO	10.8
13.559100	48.96	---	60.00	11.04	5000.0	9.000	N	FLO	10.8
13.559100	---	39.88	50.00	10.12	5000.0	9.000	N	FLO	10.8
13.560000	---	36.86	50.00	13.14	5000.0	9.000	L1	GND	10.7
13.560000	45.86	---	60.00	14.14	5000.0	9.000	L1	GND	10.7
16.836000	---	36.09	50.00	13.91	5000.0	9.000	L1	GND	10.8
16.836000	42.15	---	60.00	17.85	5000.0	9.000	L1	GND	10.8
24.008100	32.34	---	60.00	27.66	5000.0	9.000	N	GND	11.0
24.008100	---	28.30	50.00	21.70	5000.0	9.000	N	GND	11.0
27.535200	38.35	---	60.00	21.65	5000.0	9.000	L1	GND	11.1
27.535200	---	32.05	50.00	17.95	5000.0	9.000	L1	GND	11.1

Measurement uncertainty: +2.76 dB / -2.76 dB

Test: Passed

TEST EQUIPMENT USED:

20 - 22

5.2 Radiated emissions

5.2.1 Method of measurement (radiated emissions)

The radiated emission measurement is subdivided into six stages.

- A preliminary measurement carried out in a fully anechoic chamber with a fixed antenna height in the frequency range 9 kHz to 1 GHz.
- A final measurement carried out on an outdoor test site without reflecting ground plane and a fixed antenna height in the frequency range 9 kHz to 30 MHz.
- A preliminary measurement carried out in a fully anechoic chamber with a fixed antenna height in the frequency range 30 MHz to 1 GHz.
- A final measurement carried out on an open area test site with reflecting ground plane and various antenna heights in the frequency range 30 MHz to 1 GHz.
- A preliminary measurement carried out in a fully anechoic chamber with a fixed antenna height in the frequency range 1 GHz to 40 GHz.
- A final measurement carried out in a fully anechoic chamber with a fixed antenna height in the frequency range 1 GHz to 40 GHz.

Preliminary measurement (9 kHz to 30 MHz):

In the first stage a preliminary measurement will be performed in a shielded room with a measuring distance of 3 meters. Table-top devices will set up on a non-conducting support with a size of 1 m by 1.5 m and a height of 80 cm. Floor-standing devices will be placed directly on the turntable/ground plane. The set up of the Equipment under test will be in accordance to [1].

The frequency range 9 kHz to 30 MHz will be monitored with a spectrum analyser while the system and its cables will be manipulated to find out the configuration with the maximum emission levels if applicable. The EMI Receiver will be set to MAX Hold mode. The EUT and the measuring antenna will be rotated around their vertical axis to found the maximum emissions.

The resolution bandwidth of the spectrum analyser will be set to the following values:

Frequency range	Resolution bandwidth
9 kHz to 150 kHz	200 Hz
150 kHz to 30 MHz	10 kHz

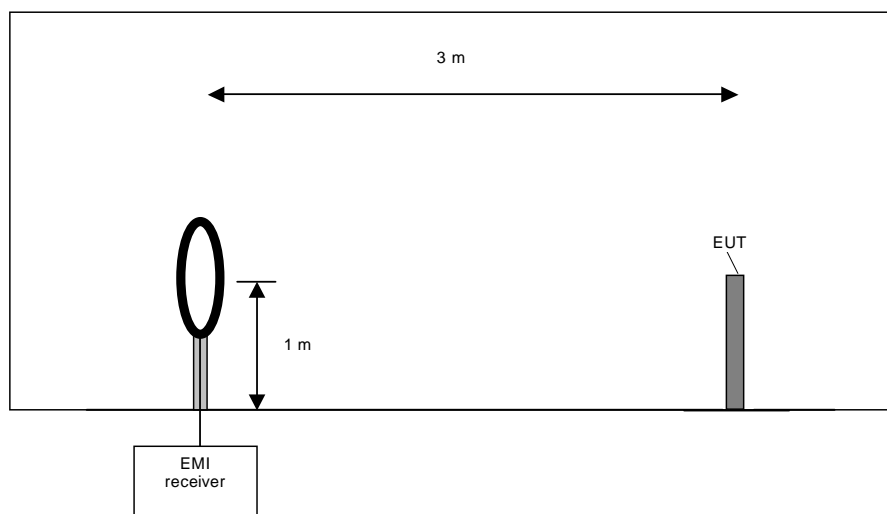

Preliminary measurement procedure:

Prescans were performed in the frequency range 9 kHz to 150 kHz and 150 kHz to 30 MHz.

The following procedure will be used:

- 1) Monitor the frequency range at horizontal polarisation and a EUT azimuth of 0 °.
- 2) Manipulate the system cables within the range to produce the maximum level of emission.
- 3) Rotate the EUT by 360 ° to maximize the detected signals.
- 4) Make a hardcopy of the spectrum.
- 5) Measure the frequencies of highest detected emission with a lower span and resolution bandwidth to increase the accuracy and note the frequency value.
- 6) Repeat steps 1) to 5) with the other orthogonal axes of the EUT (because of EUT is a module and might be used in a handheld equipment application).
- 7) Rotate the measuring antenna and repeat steps 1) to 5).

Final measurement (9 kHz to 30 MHz):

In the second stage a final measurement will be performed on an open area test site with no conducting ground plane in a measuring distances of 3 m, 10 m and 30 m. In the case where larger measuring distances are required the results will be extrapolated based on the values measured on the closer distances according to Section 15.31 (f) (2) [2]. The final measurement will be performed with a EMI Receiver set to Quasi Peak detector except for the frequency bands 9 kHz to 90 kHz and 110 kHz to 490 kHz where an average detector will be used according Section 15.209 (d) [2].

On the frequencies, which were detected during the preliminary measurements, the final measurement will be performed while rotating the EUT and the measuring antenna in the range of 0 ° to 360 ° around their vertical axis until the maximum value is found.

The resolution bandwidth of the EMI Receiver will be set to the following values:

Frequency range	Resolution bandwidth
9 kHz to 150 kHz	200 Hz
150 kHz to 30 MHz	9 kHz

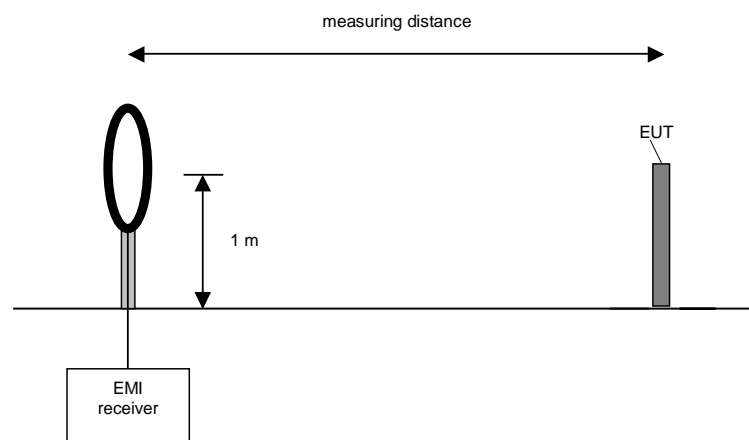

Final measurement procedure:

The following procedure will be used:

- 1) Monitor the frequency range with the measuring antenna at vertical orientation parallel to the EUT at an azimuth of 0 °.
- 2) Rotate the EUT by 360 ° to maximize the detected signals and note the azimuth and orientation.
- 3) Rotate the measuring antenna to find the maximum and note the value.
- 4) Rotate the measuring antenna and repeat steps 1) to 3) until the maximum value is found.
- 5) Repeat steps 1) to 4) with the other orthogonal axes of the EUT (if the EUT is a module and might be used in a handheld equipment application).

Preliminary measurement (30 MHz to 1 GHz)

In the first stage a preliminary measurement will be performed in a fully anechoic chamber with a measuring distance of 3 meter. Tabletop devices will set up on a non-conducting support with a size of 1 m by 1.5 m and a height of 80 cm. Floor-standing devices will be placed directly on the turntable/ground plane. The set up of the Equipment under test will be in accordance to [1].

The frequency range 30 MHz to 1 GHz will be measured with an EMI Receiver set to MAX Hold mode and a resolution bandwidth of 120 kHz. The measurement will be performed in horizontal and vertical polarisation of the measuring antenna and while rotating the EUT in its vertical axis in the range of 0 ° to 360 °.

The resolution bandwidth of the EMI Receiver will be set to the following values:

Frequency range	Resolution bandwidth
30 MHz to 1 GHz	120 kHz

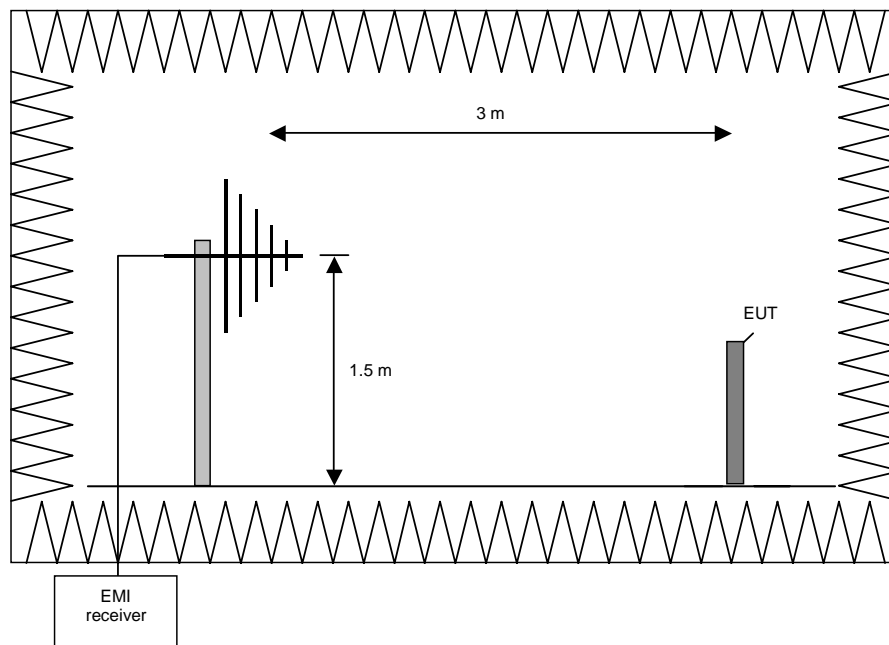

Procedure preliminary measurement:

Prescans were performed in the frequency range 30 MHz to 1 GHz.

The following procedure will be used:

1. Monitor the frequency range at horizontal polarisation and a EUT azimuth of 0 °.
2. Manipulate the system cables within the range to produce the maximum level of emission.
3. Rotate the EUT by 360 ° to maximize the detected signals.
4. Make a hardcopy of the spectrum.
5. Measure the frequency of the detected emissions with a lower span and resolution bandwidth to increase the accuracy and note the frequency value.
6. Repeat 1) to 4) with the other orthogonal axes of the EUT if handheld equipment.
7. Repeat 1) to 5) with the vertical polarisation of the measuring antenna.

Final measurement (30 MHz to 1 GHz)

A final measurement on an open area test site will be performed on selected frequencies found in the preliminary measurement. During this test the EUT will be rotated in the range of 0 ° to 360 °, the measuring antenna will be set to horizontal and vertical polarisation and raised and lowered in the range from 1 m to 4 m to find the maximum level of emissions.

The resolution bandwidth of the EMI Receiver will be set to the following values:

Frequency range	Resolution bandwidth
30 MHz to 1 GHz	120 kHz

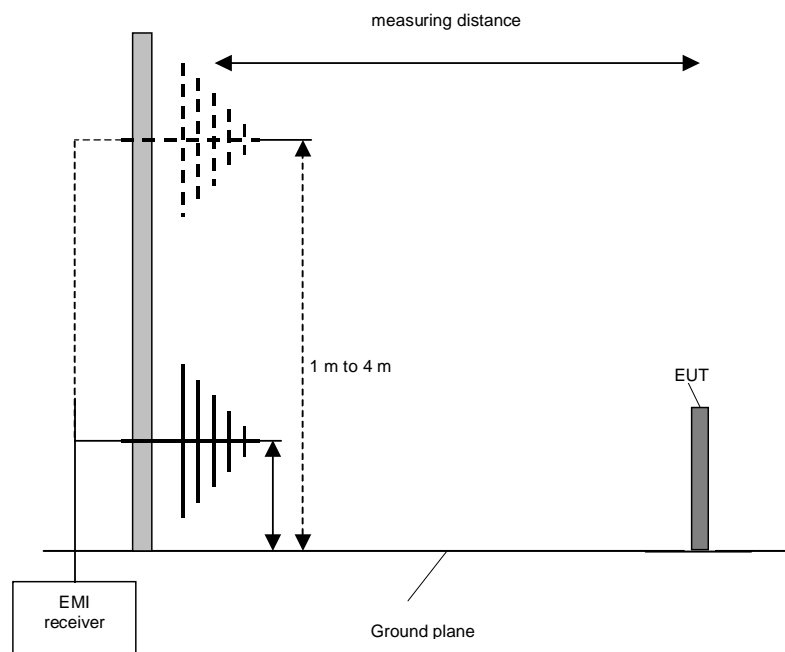

Procedure final measurement:

The following procedure will be used:

- 1) Measure on the selected frequencies at an antenna height of 1 m and a EUT azimuth of 23 °.
- 2) Move the antenna from 1 m to 4 m and note the maximum value at each frequency.
- 3) Rotate the EUT by 45 ° and repeat 2) until an azimuth of 337 ° is reached.
- 4) Repeat 1) to 3) for the other orthogonal antenna polarization.
- 5) Move the antenna and the turntable to the position where the maximum value is detected.
- 6) Measure while moving the antenna slowly +/- 1 m.
- 7) Set the antenna to the position where the maximum value is found.
- 8) Measure while moving the turntable +/- 45 °.
- 9) Set the turntable to the azimuth where the maximum value is found.
- 10) Measure with Final detector (QP and AV) and note the value.
- 11) Repeat 5) to 10) for each frequency.
- 12) Repeat 1) to 11) for each orthogonal axes of the EUT if handheld equipment.

Preliminary and final measurement (1 GHz to 110 GHz)

This measurement will be performed in a fully anechoic chamber. Table top devices will set up on a non-conducting turn device on the height of 1.5 m. The set-up of the Equipment under test will be in accordance to [1].

The frequency range will be divided into different sub ranges depending of the frequency range of the used horn antenna. The spectrum analyser set to MAX Hold mode and a resolution bandwidth of 100 kHz. The measurement will be performed in horizontal and vertical polarisation of the measuring antenna and while rotating the EUT in its vertical axis in the range of 0 ° to 360 °. This measurement is repeated after raising the EUT in 30 ° steps according 6.6.5.4 in [1].

The resolution bandwidth of the EMI Receiver will be set to the following values:

Frequency range	Resolution bandwidth
1 GHz to 4 GHz	1 MHz
4 GHz to 12 GHz	1 MHz
12 GHz to 18 GHz	1 MHz
18 GHz to 26.5 GHz	1 MHz
26.5 GHz to 40 GHz	1 MHz
40 GHz to 60 GHz	1 MHz
50 GHz to 75 GHz	1 MHz
75 GHz to 110 GHz	1 MHz

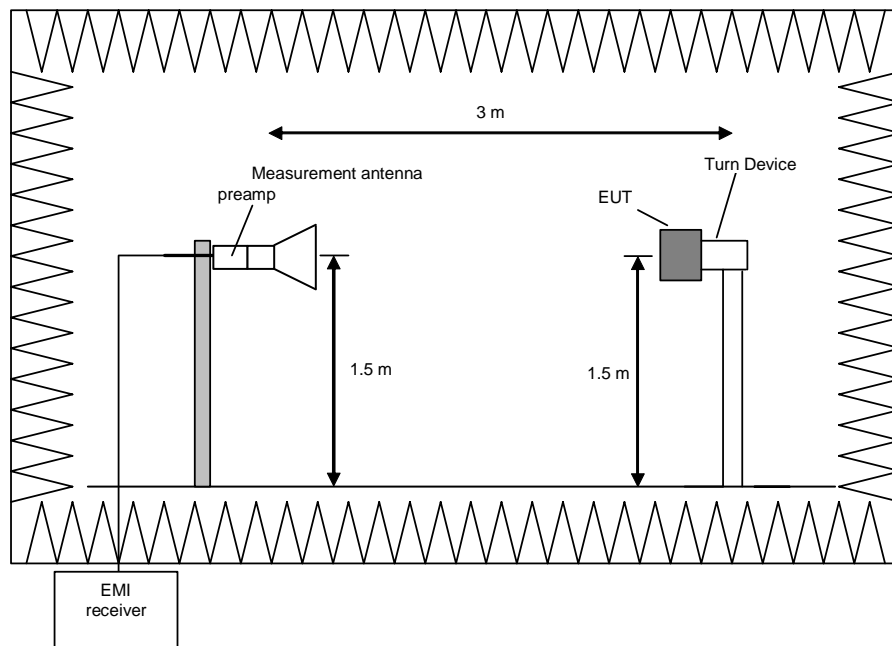

Procedure preliminary measurement:

Prescans were performed in the frequency range 1 to 110 GHz.

The following procedure will be used:

1. Monitor the frequency range at horizontal polarisation and a EUT azimuth of 0 °.
2. Rotate the EUT by 360° to maximize the detected signals.
3. Repeat 1) to 2) with the vertical polarisation of the measuring antenna.
4. Make a hardcopy of the spectrum.
5. Repeat 1) to 4) with the EUT raised by an angle of 30° (60°, 90°, 120° and 150°) according to 6.6.5.4 in [1].
6. Measure the frequency of the detected emissions with a lower span and resolution bandwidth to increase the accuracy and note the frequency value.
7. The measurement antenna polarisation, with the according EUT position (Turntable and Turn device) which produces the highest emission for each frequency will be used for the final measurement. The six closest values to the applicable limit will be used for the final measurement.

Final measurement (1 GHz to 110 GHz)

The frequency range will be divided into different sub ranges depending of the frequency range of the used antenna. The EMI Receiver set to peak and average mode and a resolution bandwidth of 1 MHz. The measurement will be performed by rotating the turntable through 0 to 360° in the worst-case EUT orientation which was obtained during the preliminary measurements.

The resolution bandwidth of the EMI Receiver will be set to the following values:

Frequency range	Resolution bandwidth
1 GHz to 4 GHz	1 MHz
4 GHz to 12 GHz	1 MHz
12 GHz to 18 GHz	1 MHz
18 GHz to 26.5 GHz	1 MHz
26.5 GHz to 40 GHz	1 MHz
40 GHz to 60 GHz	1 MHz
50 GHz to 75 GHz	1 MHz
75 GHz to 110 GHz	1 MHz

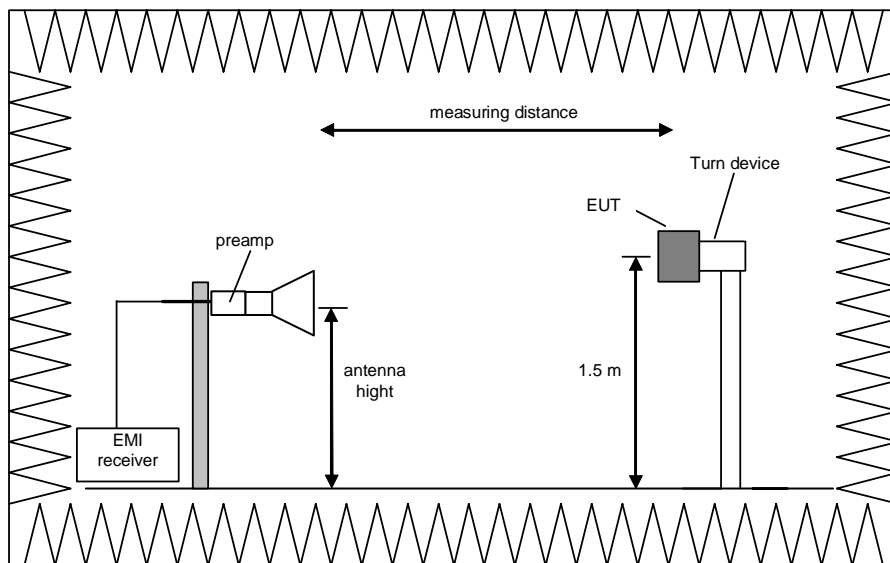

Procedure of measurement:

The measurements were performed in the frequency range 1 GHz to 110 GHz.

The following procedure will be used:

- 1) Set the turntable and the turn device to obtain the worst-case emission for the first frequency identified in the preliminary measurements.
- 2) Set the measurement antenna polarisation to the orientation with the highest emission for the first frequency identified in the preliminary measurements.
- 3) Set the spectrum analyser to EMI mode with peak and average detector activated.
- 4) Rotate the turntable from 0° to 360° to find the EUT angle that produces the highest emissions.
- 5) Note the highest displayed peak and average values
- 6) Repeat the steps 1) to 5) for each frequency detected during the preliminary measurements.

5.2.2 Results preliminary measurement 9 kHz to 1 GHz

Ambient temperature	22 °C	Relative humidity	49 %
---------------------	-------	-------------------	------

Position of EUT:	The EUT was set-up on a non-conducting table.
Cable guide:	The cable of the EUT was fixed on the non-conducting table. For further information of the cable guide refer to the pictures in annex A of this test report.
Test record:	The test was carried out in TX-test mode of the EUT (refer also clause 2 of this test report). All results are shown in the following.
Power supply:	During this test the EUT was powered with 5.00 V DC via USB by a laptop.
Frequency range:	According to [2] from 9 kHz to 1 GHz.

170923: Spurious emissions from 9 kHz to 30 MHz

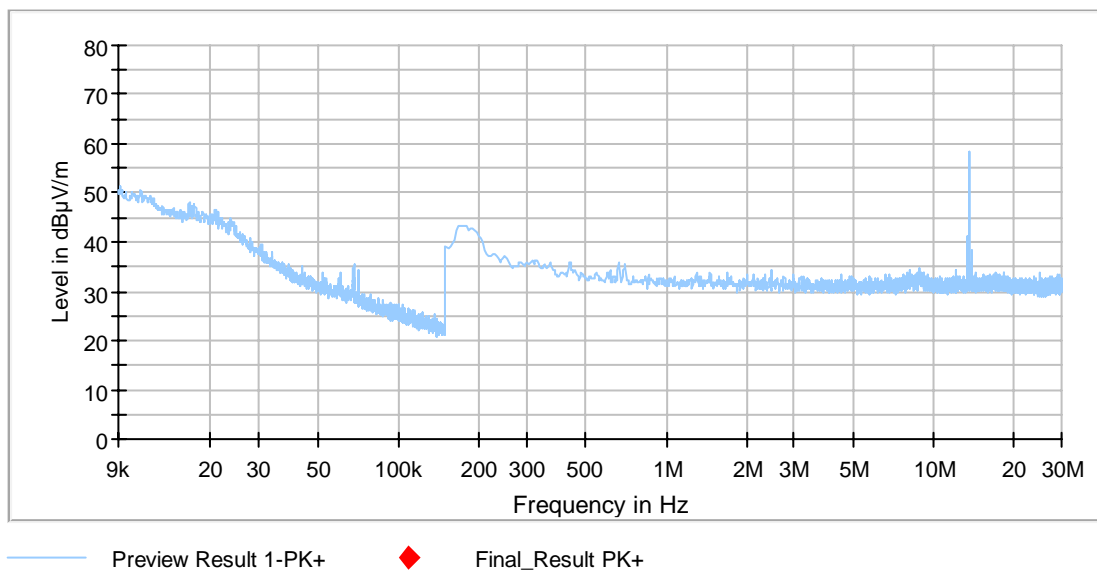

Except the fundamental of the EUT at no frequency was a value above the noise of the system therefore only a final measurement for the fundamental on the open area test site was carried out. No spurious emissions caused by the equipment under test were found.

The following emission was found according to [2] and [3]. (fundamental of transmitter)

13.56 MHz.

Remark: No further emissions caused by the equipment under were found.

170923FCCah2: Spurious emissions from 30 MHz to 1000 MHz

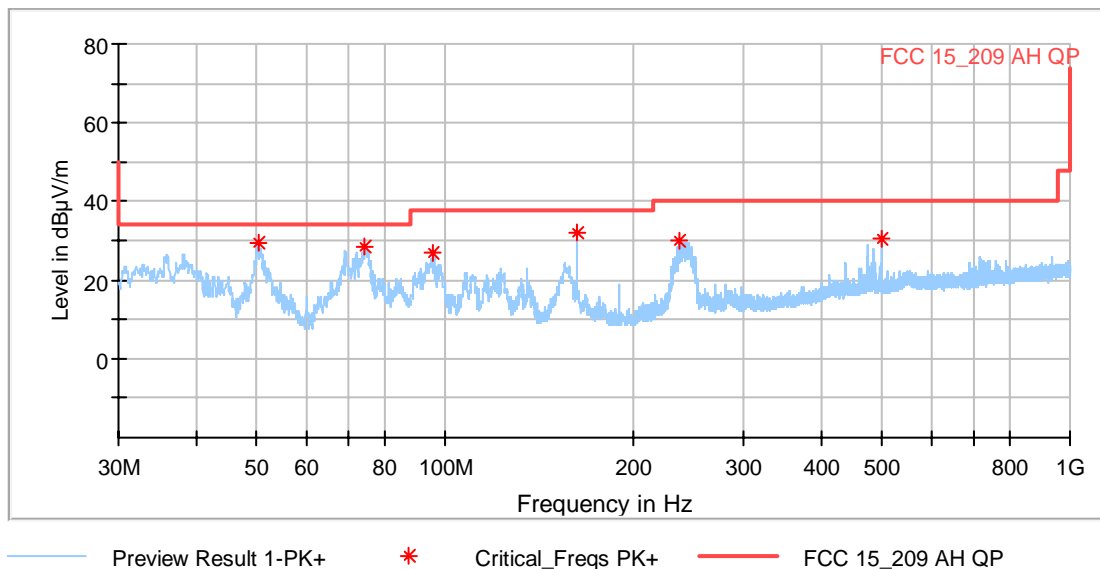

The following frequencies were found outside and inside the restricted bands found according to FCC 47 CFR Part 15 section 15.209.

Frequency (MHz)
50.273000
74.571500
95.911500
162.730180
237.531500
499.965000

Test equipment used (see chapter 6)

30 , 32 – 35, 44, 51

5.2.3 Result final measurement from 9 kHz to 30 MHz

Ambient temperature	16 °C	Relative humidity	56 %
---------------------	-------	-------------------	------

Position of EUT: The EUT was set-up on a non-conducting table of a height of 0.8 m. The distance between EUT and antenna was 3 m and 10 m.

Cable guide: The cable of the EUT was fixed on the non-conducting support. For further information of the cable guide refer to the pictures in annex A of this test report.

Test record: The test was carried out in TX-test mode of the EUT (refer also clause 2 of this test report). All results are shown in the following.

Power supply: During this test the EUT was supplied with 5.00 V DC via USB by a laptop Lenovo ThinkPad X201T.

Test results: The test results were calculated with the following formula:

$$\text{Result [dB}\mu\text{V/m]} = \text{reading [dB}\mu\text{V]} + \text{antenna factor [dB/m]} - \text{distance correction (dB)}$$

Results 9kHz - 30 MHz								
Frequency [MHz]	Reading [dBμV]	Result* [dBμV/m]	Limit acc. 15.209 [dBμV/m]	Margin [dB]	Detector (acc. to §15.209 (d)	Antenna factor [dB/m]	Measuring Distance [m]	Distance correction factor** [dB]
13.560000	35.2	15.1 @ 30m	29.5	14.4	QP	19.9	3	40.0
Measurement uncertainty			+/- 4.69 dB					

Note: *Result @ norm dist = Reading + Antenna factor - Distance Extrapolation Factor

** 40dB/decade according Part §15.31 (f) (2)

Remark: At 10m measuring distance the signal of the EUT was below the sensitivity of the measuring system.

Test: Passed

Test equipment used for the test:

31, 51 – 53

5.2.4 Result final measurement from 30 MHz to 1 GHz

Ambient temperature	21 °C	Relative humidity	59 %
---------------------	-------	-------------------	------

In this case it was not necessary to carry out subsequent measurements because at no frequency was a value above the noise of the system.

Position of EUT: The EUT was setup on a non-conducting table of a height of 0.8 m. The distance between EUT and antenna was 3 m.

Test record: The test was carried out in TX-test mode of the EUT (refer also clause 2 of this test report). All results are shown in the following.

Power supply: During this test the EUT was powered with 5.00 V DC via USB by a laptop.

Test results: The test results were calculated with the following formula:

$$\text{Result [dB}\mu\text{V/m]} = \text{reading [dB}\mu\text{V]} + \text{cable loss [dB]} + \text{antenna factor [dB/m]}$$

The results of the standard subsequent measurement on the open area test site are indicated in the table below. The limits as well as the measured results (levels) refer to the above mentioned standard while taking account of the specified requirements for a 3 m measuring distance.

The measurement time with the quasi-peak measuring detector is 1 seconds.

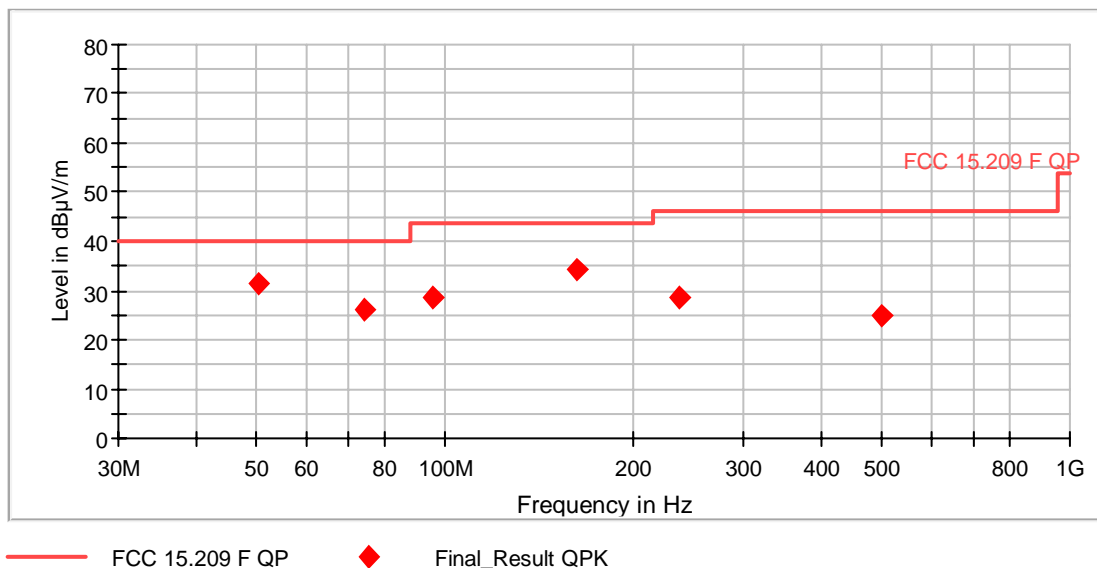

170923_FCC_Coloc_BT_NFC209

31.08.2017

Final Result

Frequency (MHz)	QuasiPeak (dB μ V/m)	Limit (dB μ V/m)	Margin (dB)	Meas. Time (ms)	Bandwidth (kHz)	Height (cm)	Pol	Azimuth (deg)	Corr. (dB)
50.273000	31.51	40.00	8.49	1000.0	120.000	102.0	V	78.0	16.2
74.571500	26.00	40.00	14.00	1000.0	120.000	162.0	V	262.0	14.8
95.911500	28.39	43.50	15.11	1000.0	120.000	127.0	V	10.0	18.2
162.730180	34.15	43.50	9.35	1000.0	120.000	102.0	V	93.0	19.3
237.531500	28.41	46.00	17.59	1000.0	120.000	112.0	H	142.0	20.3
499.965000	24.89	46.00	21.11	1000.0	120.000	104.0	V	231.0	27.5
Measurement uncertainty				+/- 4.8 dB					

Test: Passed

Test equipment used (see chapter 6):

14 – 21

5.3 99 % bandwidth

5.3.1 Method of measurement

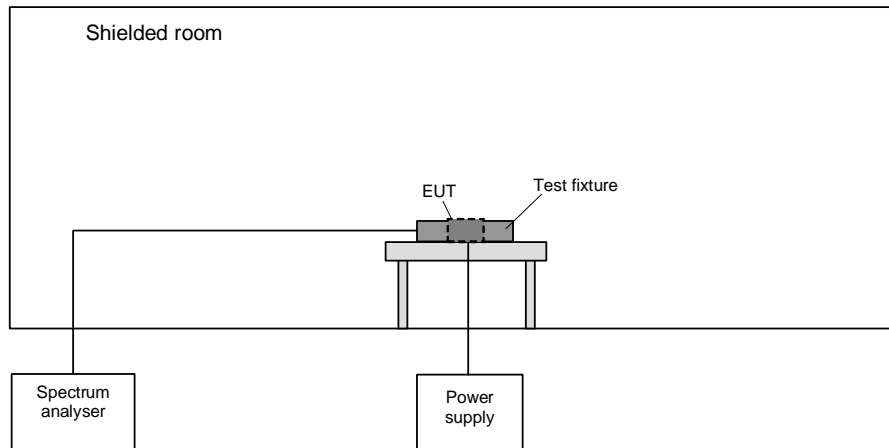

The following procedure will be used for the occupied bandwidth measurement according to [1]:

The span of the analyzer shall be set to capture all products of the modulation process, including the emission skirts. The resolution bandwidth shall be set to as close to 1% of the selected span as is possible without being below 1%. The video bandwidth shall be set to 3 times the resolution bandwidth. Video averaging is not permitted. Where practical, a sampling detector shall be used since a peak or, peak hold, may produce a wider bandwidth than actual.

The trace data points are recovered and are directly summed in linear terms. The recovered amplitude data points, beginning at the lowest frequency, are placed in a running sum until 0.5% of the total is reached and that frequency recorded. The process is repeated for the highest frequency data points. This frequency is recorded.

The span between the two recorded frequencies is the occupied bandwidth.

5.3.2 Test results

Ambient temperature:	21 °C	Relative humidity:	62 %
----------------------	-------	--------------------	------

Test record: The test was carried out in TX-test mode of the EUT (refer also clause 2 of this test report). All results are shown in the following.

Power supply: During this test the EUT was supplied with 5.00 V DC via USB by a laptop Lenovo ThinkPad X201T.

170923_99.wmf: 99 % bandwidth:

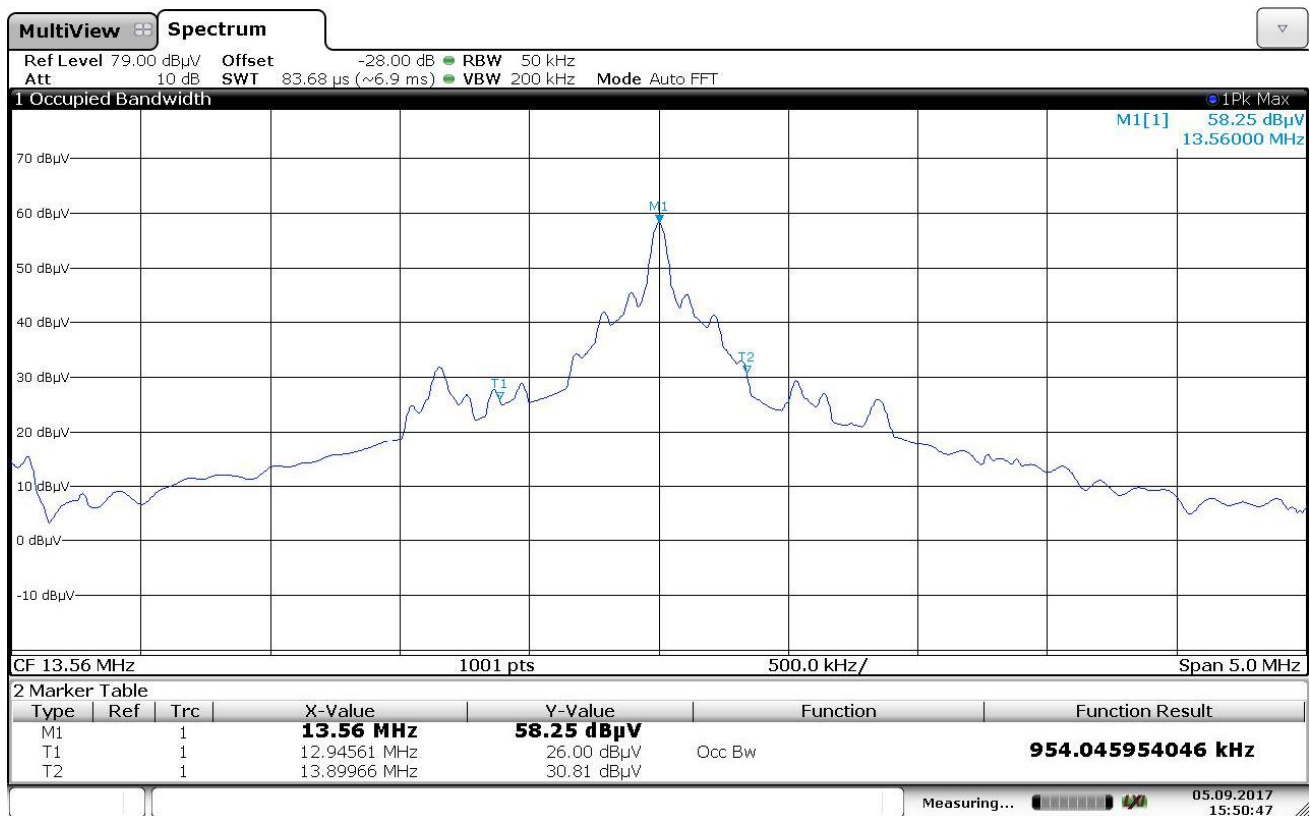

Date: 5.SEP.2017 15:50:47

F_L	F_U	BW ($F_U - F_L$)
12.94561 MHz	13.89966 MHz	909.04595 kHz
Measurement uncertainty		$< 1 \cdot 10^{-7}$

Test equipment used (see chapter 6)

43, 54

6 Test equipment

No.	Test equipment	Type	Manufacturer	Serial No.	PM. No.	Cal. Date	Cal. due
14	Open area test site	-	Phoenix Testlab	-	480085	Weekly verification (system cal.)	
15	Measuring receiver	ESIB7	Rohde & Schwarz	100304	480521	02/18/2016	02/2018
16	Controller	HD100	Deisel	100/670	480139	-	-
17	Turntable	DS420HE	Deisel	420/620/80	480087	-	-
18	Antenna support	AS615P	Deisel	615/310	480086	-	-
19	Antenna	CBL6111 D	Chase	25761	480894	09/18/2014	09/2017
20	EMI-Software	EMC 32	Rohde & Schwarz	-	481022	-	-
21	6 dB attenuator	R412706000	Radiall	9833	410082	Annual verification	
30	Fully anechoic chamber M20	-	Albatross Projects	B83107-E2439-T232	480303	Weekly verification (system cal.)	
31	Measuring receiver	ESI 40	Rohde & Schwarz	100064	480355	02/15/2017	02/2018
32	Controller	MCU	Maturo	MCU/043/971107	480832	-	-
33	Turntable	DS420HE	Deisel	420/620/80	480315	-	-
34	Antenna support	AS615P	Deisel	615/310	480187	-	-
35	Antenna	CBL6112 B	Chase	2688	480328	19/06/2017	06/2020
43	Signal & Spectrum Analyzer	FSW43	Rohde & Schwarz	100586	481720	02/24/2016	02/2018
44	RF-cable No. 36	Sucoflex 106B	Suhner	0522/6B	480571	Weekly verification (system cal.)	
51	Loop antenna	HFH2-Z2	Rohde & Schwarz	832609/014	480059	02/29/2016	02/2018
53	Outdoor test site	-	Phoenix Testlab	-	480293	-	-
54	Loop Antenna $\lambda E = 110$ mm	-	Phoenix Testlab	-	410084	Weekly verification (system cal.)	

