

FCC TEST REPORT  
for  
Winner Wave Limited

EZCast Pro Box  
Model No.: B02

Prepared for : Winner Wave Limited  
Address : 4F-5, No.736, Jhongjheng Road, Jhonghe Dist., New Taipei City,  
Taiwan

Prepared By : Shenzhen Anbotek Compliance Laboratory Limited  
Address : 1/F., Building 1, SEC Industrial Park, No.0409 Qianhai Road,  
Nanshan District, Shenzhen, Guangdong, China  
Tel: (86) 755-26066544  
Fax: (86) 755-26014772

Report Number : R0116061074Y  
Date of Test : Jun. 30~Sept. 09, 2016  
Date of Report : Sept. 12, 2016

## TABLE OF CONTENT

Description	Page
Test Report	
<b>1. GENERAL INFORMATION.....</b>	<b>5</b>
1.1. Description of Device (EUT).....	5
1.2. Auxiliary Equipment Used during Test.....	6
1.3. Description of Test Facility.....	6
1.4. Measurement Uncertainty.....	6
<b>2. TEST METHODOLOGY.....</b>	<b>7</b>
2.1. Summary of Test Results.....	7
2.2. Description of Test Modes.....	7
<b>3. CONDUCTED EMISSION TEST.....</b>	<b>8</b>
3.1. Block Diagram of Test Setup.....	8
3.2. Power Line Conducted Emission Measurement Limits (15.207).....	8
3.3. Configuration of EUT on Measurement.....	8
3.4. Operating Condition of EUT.....	8
3.5. Test Procedure.....	9
3.6. Test equipment.....	9
3.7. Power Line Conducted Emission Measurement Results.....	9
<b>4.BANDWIDTH.....</b>	<b>14</b>
4.1. Test Limit.....	14
4.2. Test Setup.....	14
4.3. Test Procedure.....	14
4.4. Test Equipment.....	15
4.5. Test Results.....	15
<b>5. MAXIMUM CONDUCTED OUTPUT POWER TEST.....</b>	<b>26</b>
5.1. Test Limit.....	26
5.2. Test Setup.....	27
5.3. Test Procedure.....	27
5.4. Test Equipment.....	28
5.5. Test Results.....	29
<b>6. PEAK POWER SPECTRUAL DENSITY TEST.....</b>	<b>35</b>
6.1. Test Limit.....	35
6.2. Test Setup.....	36
6.3. Test Procedure.....	36
6.4. Test Equipment.....	37
6.5. Test Results.....	37
<b>7. RADIATED EMISSION TEST.....</b>	<b>44</b>

7.1. Test Limit.....	44
7.2. Test Setup.....	45
7.3. Test Procedure.....	46
7.4. Test Equipment.....	46
7.5. Test Results.....	47
<b>8. BAND EDGE TEST.....</b>	<b>54</b>
8.1. Test Limit.....	54
8.2. Test Setup.....	54
8.3. Test Procedure.....	54
8.4. Test Equipment.....	55
8.5. Test Results.....	55
<b>9. ANTENNA APPLICATION.....</b>	<b>72</b>
9.1. Antenna requirement.....	72
9.2. Result.....	72
<b>10. PHOTOGRAPH.....</b>	<b>73</b>
10.1. Photo of Conducted Emission Measurement.....	73
10.2. Photo of Radiation Emission Test.....	74
<b>APPENDIX I (EXTERNAL PHOTOS).....</b>	<b>76</b>
<b>APPENDIX II (INTERNAL PHOTOS).....</b>	<b>80</b>

## TEST REPORT

Applicant : Winner Wave Limited  
Manufacturer : BIWIN STORAGE TECHNOLOGY LIMITED  
EUT : EZCast Pro Box  
Model No. : B02  
Serial No. : N.A.  
Trade Mark : EZCast  
Rating : DC 5V

Measurement Procedure Used:  
FCC Part15 Subpart E 2015, Paragraph 15.407

The device described above is tested by Shenzhen Anbotek Compliance Laboratory Limited to determine the maximum emission levels emanating from the device and the severe levels of the device can endure and its performance criterion. The measurement results are contained in this test report and Shenzhen Anbotek Compliance Laboratory Limited is assumed full of responsibility for the accuracy and completeness of these measurements. Also, this report shows that the EUT (Equipment Under Test) is technically compliant with the FCC Part 15 Subpart E requirements.

This report applies to above tested sample only and shall not be reproduced in part without written approval of Shenzhen Anbotek Compliance Laboratory Limited.

Date of Test : Jun. 30~Sept. 09, 2016

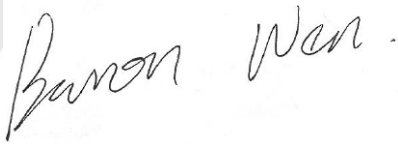
Prepared by :   
(Tested Engineer / Baron Wen)

Reviewer :   
(Project Manager / Amy Ding)

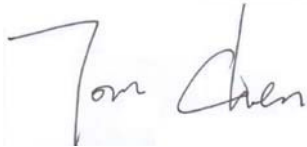
Approved & Authorized Signer :   
(Manager / Tom Chen)



## 1. GENERAL INFORMATION

### 1.1. Description of Device (EUT)

EUT	: EZCast Pro Box
Model Number	: B02
Test Power Supply	: AC 120V, 60Hz for adapter/ AC 240V, 60Hz for adapter
Adapter	: Model: BX-0501500 Input: AC 100-240V, 50/60Hz Output: DC 5.0V, 1500mA
RF Transmission Frequency	: WiFi: 2412MHz~2462MHz (802.11b/802.11g/802.11n(HT20)) 2422MHz~2452MHz (802.11n(HT40)) 5G: 5180MHz~5240MHz 5745MHz~5825MHz (802.11n(HT20)) 5G: 5190MHz~5230MHz 5755MHz~5795MHz (802.11n(HT40)) (802.11ac(HT40)) 5G: 5210MHz 5775MHz (802.11ac(HT80))
Antenna Specification	: WiFi: 4.91dBi 5G: 4.75dBi
Modulation	: WiFi&5G: 802.11b CCK; 802.11g OFDM; 802.11n MCS;802.11ac MCS
Applicant Address	: Winner Wave Limited 4F-5, No.736, Jhongjheng Road, Jhonghe Dist., New Taipei City, Taiwan
Manufacturer Address	: BIWIN STORAGE TECHNOLOGY LIMITED 1F, 2F, 4F, 5F, Block 4, Tongfuyu Industrial Park, Taoyuan Street, Nanshan, Shenzhen, Guangdong, P.R. China
Factory Address	: Biwin Semiconductor (HK) Company Limited 5/F, Block4, Tongfuyu Industrial Park, Tanglang, Xili, NanShan, Shenzhen, China
Date of receipt	: Jun. 30, 2016
Date of Test	: Jun. 30~Sept. 09, 2016

## 1.2. Auxiliary Equipment Used during Test

TV : Manufacturer: SONY  
M/N: KDL-26EX550  
S/N: 1012240  
CE , FCC: DOC

## 1.3. Description of Test Facility

The test facility is recognized, certified, or accredited by the following organizations:

### **FCC-Registration No.: 752021**

Shenzhen Anbotek Compliance Laboratory Limited, EMC Laboratory has been registered and fully described in a report filed with the (FCC) Federal Communications Commission. The acceptance letter from the FCC is maintained in our files. Registration 752021, July 06, 2016.

### **IC-Registration No.: 8058A-1**

Shenzhen Anbotek Compliance Laboratory Limited., EMC Laboratory has been registered and fully described in a report filed with the (IC) Industry Canada. The acceptance letter from the IC is maintained in our files. Registration 8058A, Jun. 13, 2016.

### **Test Location**

All Emissions tests were performed at  
Shenzhen Anbotek Compliance Laboratory Limited. at 1/F., Building 1, SEC  
Industrial Park, No.0409 Qianhai Road, Nanshan District, Shenzhen, Guangdong,  
China

## 1.4. Measurement Uncertainty

Radiation Uncertainty : Ur = 4.1 dB (Horizontal)  
Ur = 4.3 dB (Vertical)  
Conduction Uncertainty : Uc = 3.4dB

## 2. TEST METHODOLOGY

The tests documented in this report were performed in accordance with ANSI C63.10: 2013 and FCC Part 15, Paragraph 15.247.

### 2.1. Summary of Test Results

The EUT has been tested according to the following specifications:

Standard	Test Type	Result
FCC Part 15, Paragraph 15.207 & 15.407	Conducted Emission	PASS
FCC Part 15, Paragraph 15.407(b)(1)(4)(5)(7)	Undesireable Emission Restricted Band	PASS
FCC Part 15, Paragraph 15.407(a)(1)	26dB Bandwidth	PASS
FCC Part 15, Paragraph 15.407(a)(1)(2)(3)	Maximum Conducted Output Power	PASS
FCC Part 15, Paragraph 15.407(a)(1)(2)(3)	Peak Power Spectrual Density	PASS
FCC Part 15, Paragraph 15.203	Antenna Requirement	PASS

### 2.2. Description of Test Modes

The EUT has been tested under operating condition.

Software used to control the EUT for staying in continuous transmitting and receiving mode is programmed.

Mode	Test channel	Mode	Test channel
IEEE802.11n(HT20)	5180MHz	IEEE802.11n(HT20)	5745MHz
	5200MHz		5785MHz
	5240MHz		5825MHz
IEEE802.11n(HT40)	5190MHz	IEEE802.11n(HT40)	5755MHz
	5230MHz		5795MHz
IEEE802.11ac(HT20)	5180MHz	IEEE802.11ac(HT20)	5745MHz
	5200MHz		5785MHz
	5240MHz		5825MHz
IEEE802.11ac(HT40)	5190MHz	IEEE802.11ac(HT40)	5755MHz
	5230MHz		5795MHz
IEEE802.11ac(HT80)	5210MHz	IEEE802.11ac(HT80)	5775MHz

### 3. Conducted Emission Test

#### 3.1. Block Diagram of Test Setup

##### 3.1.1. Block diagram of connection between the EUT and simulators

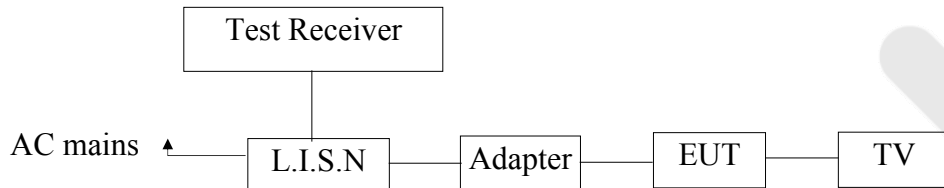

#### 3.2. Power Line Conducted Emission Measurement Limits (15.207)

Frequency MHz	Limits dB(μV)	
	Quasi-peak Level	Average Level
0.15 ~ 0.50	66 ~ 56*	56 ~ 46*
0.50 ~ 5.00	56	46
5.00 ~ 30.00	60	50

- Notes: 1. \*Decreasing linearly with logarithm of frequency.  
2. The lower limit shall apply at the transition frequencies.

#### 3.3. Configuration of EUT on Measurement

The following equipments are installed on Power Line Conducted Emission Measurement to meet the commission requirement and operating regulations in a manner which tends to maximize its emission characteristics in a normal application.

#### 3.4. Operating Condition of EUT

- 3.4.1. Setup the EUT and simulator as shown as Section 3.1.
- 3.4.2. Turn on the power of all equipment.
- 3.4.3. Let the EUT work in test mode (Playing video+HDMI output+Internet connect mode, Playing video+VGA output+Internet connect+WiFi operating mode) and measure it.

### 3.5. Test Procedure

The EUT system is connected to the power mains through a line impedance stabilization network (L.I.S.N.). This provides a 50ohm coupling impedance for the EUT system. Please refer the block diagram of the test setup and photographs. Both sides of AC line are checked to find out the maximum conducted emission. In order to find the maximum emission levels, the relative positions of equipment and all of the interface cables shall be changed according to FCC ANSI C63.10-2013 on Conducted Emission Measurement.

The bandwidth of test receiver (ESCI) set at 9KHz.

The frequency range from 150KHz to 30MHz is checked.

The test results are reported on Section 3.6.

### 3.6. Test equipment

Item	Equipment	Manufacturer	Model No.	Serial No.	Last Cal.	Cal. Interval
1.	Two-Line V-network	Rohde & Schwarz	ENV216	100055	Apr. 16, 2016	1 Year
2.	EMI Test Receiver	Rohde & Schwarz	ESCI	100627	Apr. 16, 2016	1 Year
3.	RF Switching Unit	Compliance Direction	RSU-M2	38303	Apr. 16, 2016	1 Year

### 3.7. Power Line Conducted Emission Measurement Results

**PASS.**

The frequency range from 150KHz to 30 MHz is investigated.

The EUT was tested on (Playing video+HDMI output+Internet connect mode, Playing video+VGA output+Internet connect+WiFi operating mode) modes, only the worst data of (Playing video+HDMI output+Internet connect mode) is attached in the following pages.

**CONDUCTED EMISSION TEST DATA**

Test Site: 1# Shielded Room  
 Operating Condition: Playing video+HDMI output+Internet connect mode  
 Test Specification: AC 120V, 60Hz for adapter  
 Comment: Live Line  
 Tem.:25°C Hum.:50%

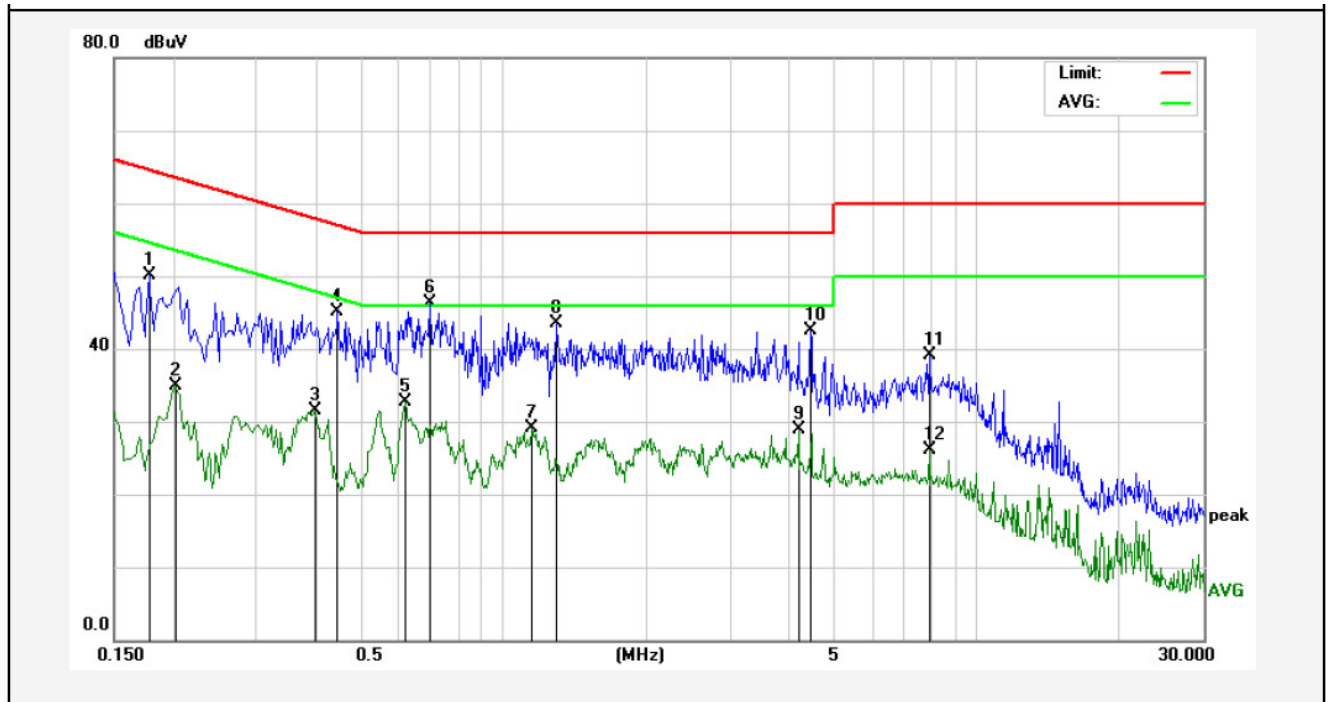

No.	Freq. (MHz)	Reading (dBuV)	Factor (dB)	Result (dBuV)	Limit (dBuV)	Over Limit (dB)	Detector	Remark
1	0.1780	30.06	19.90	49.96	64.57	-14.61	QP	
2	0.2020	14.96	19.90	34.86	53.52	-18.66	AVG	
3	0.3980	11.53	19.89	31.42	47.89	-16.47	AVG	
4	0.4460	25.06	19.96	45.02	56.95	-11.93	QP	
5	0.6180	12.70	20.01	32.71	46.00	-13.29	AVG	
6	0.6980	26.22	20.02	46.24	56.00	-9.76	QP	
7	1.1420	9.18	20.12	29.30	46.00	-16.70	AVG	
8	1.2900	23.59	20.13	43.72	56.00	-12.28	QP	
9	4.1979	8.97	20.18	29.15	46.00	-16.85	AVG	
10	4.4540	22.56	20.18	42.74	56.00	-13.26	QP	
11	7.9260	19.16	20.26	39.42	60.00	-20.58	QP	
12	7.9260	6.04	20.26	26.30	50.00	-23.70	AVG	

**CONDUCTED EMISSION TEST DATA**

Test Site: 1# Shielded Room  
 Operating Condition: Playing video+HDMI output+Internet connect mode  
 Test Specification: AC 120V, 60Hz for adapter  
 Comment: Neutral Line  
 Tem.:25°C Hum.:50%

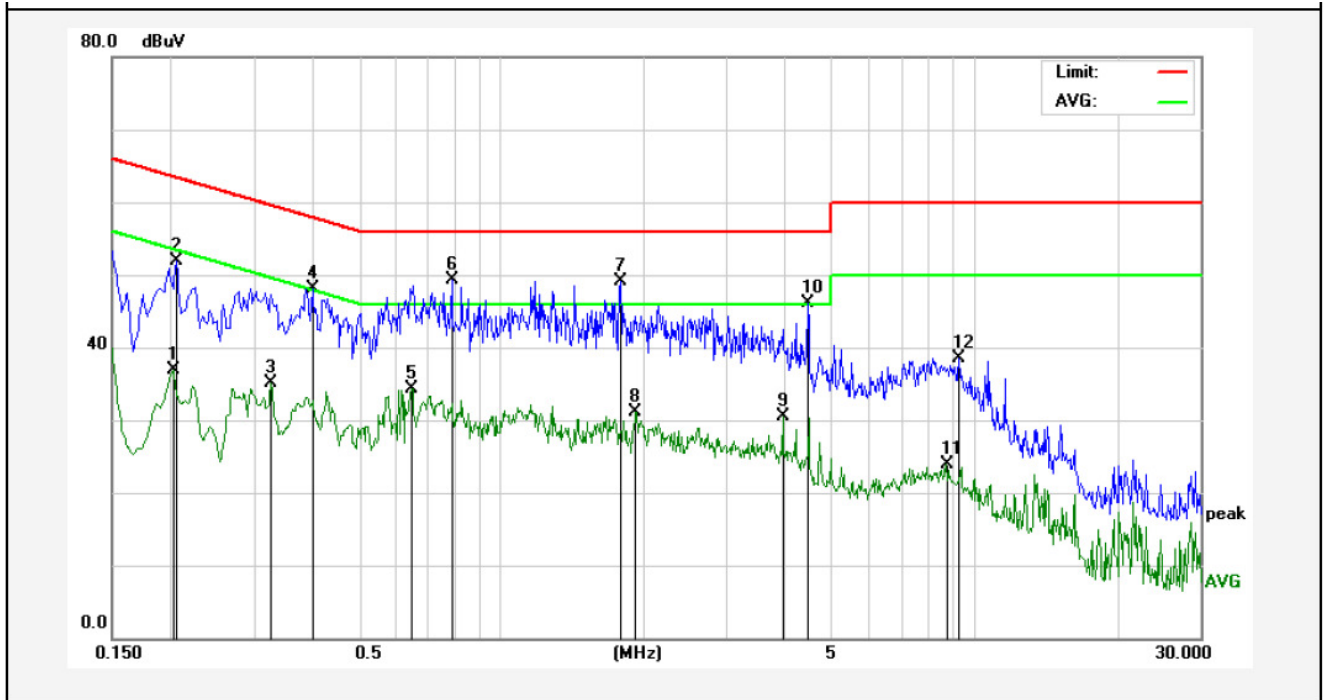

No.	Freq. (MHz)	Reading (dBuV)	Factor (dB)	Result (dBuV)	Limit (dBuV)	Over Limit (dB)	Detector	Remark
1	0.2020	16.83	19.90	36.73	53.52	-16.79	AVG	
2	0.2060	31.93	19.90	51.83	63.36	-11.53	QP	
3	0.3260	15.09	19.89	34.98	49.55	-14.57	AVG	
4	0.3980	28.19	19.93	48.12	57.89	-9.77	QP	
5	0.6460	14.25	20.02	34.27	46.00	-11.73	AVG	
6	0.7860	29.26	20.04	49.30	56.00	-6.70	QP	
7	1.7820	29.01	20.04	49.05	56.00	-6.95	QP	
8	1.9220	11.01	20.14	31.15	46.00	-14.85	AVG	
9	3.9340	10.55	20.17	30.72	46.00	-15.28	AVG	
10	4.4460	26.09	20.19	46.28	56.00	-9.72	QP	
11	8.7180	3.84	20.26	24.10	50.00	-25.90	AVG	
12	9.2660	18.45	20.28	38.73	60.00	-21.27	QP	



**CONDUCTED EMISSION TEST DATA**

Test Site: 1# Shielded Room  
 Operating Condition: Playing video+HDMI output+Internet connect mode  
 Test Specification: AC 240V, 60Hz for adapter  
 Comment: Live Line  
 Tem.:25°C Hum.:50%

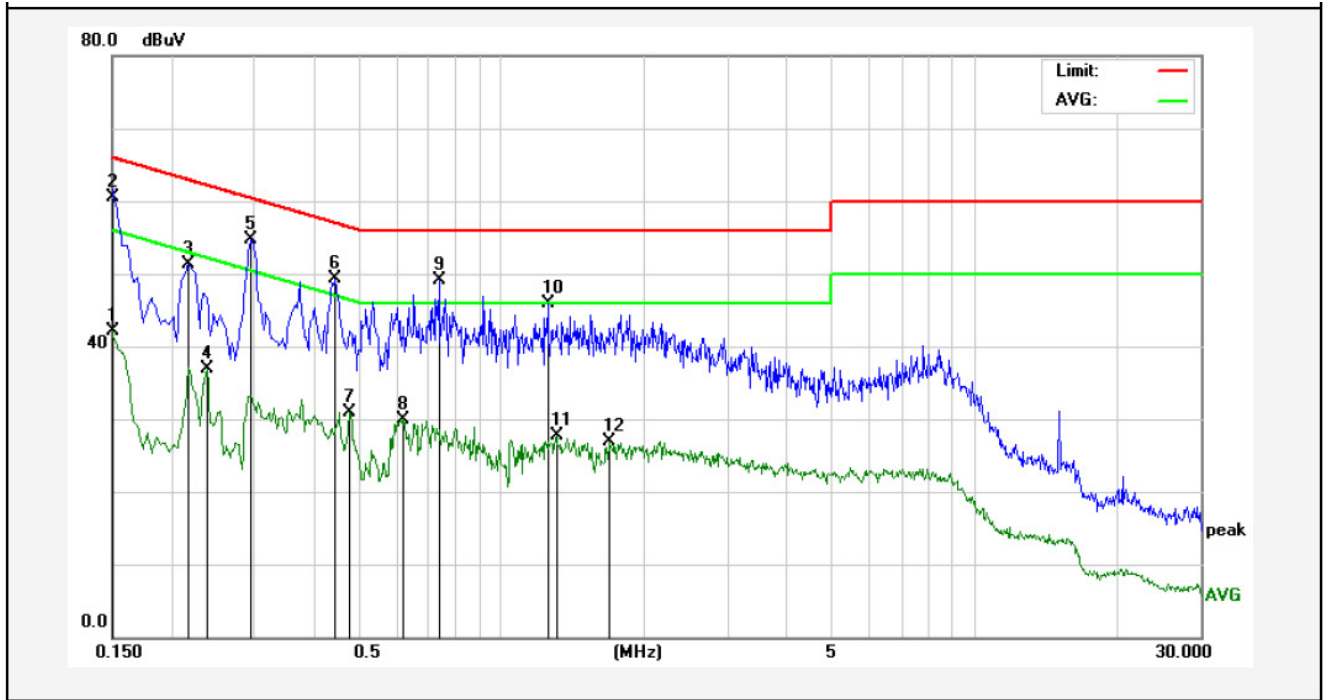

No.	Freq. (MHz)	Reading (dBuV)	Factor (dB)	Result (dBuV)	Limit (dBuV)	Over Limit (dB)	Detector	Remark
1	0.1499	22.07	19.90	41.97	56.00	-14.03	AVG	
2	0.1500	40.47	19.90	60.37	65.99	-5.62	QP	
3	0.2180	31.38	19.90	51.28	62.89	-11.61	QP	
4	0.2380	16.88	19.89	36.77	52.16	-15.39	AVG	
5	0.2940	34.69	19.89	54.58	60.41	-5.83	QP	
6	0.4460	29.23	19.91	49.14	56.95	-7.81	QP	
7	0.4780	10.96	19.92	30.88	46.37	-15.49	AVG	
8	0.6180	10.00	19.93	29.93	46.00	-16.07	AVG	
9	0.7380	29.09	19.95	49.04	56.00	-6.96	QP	
10	1.2500	26.00	20.12	46.12	56.00	-9.88	QP	
11	1.3060	7.66	20.13	27.79	46.00	-18.21	AVG	
12	1.6900	7.00	20.13	27.13	46.00	-18.87	AVG	



**CONDUCTED EMISSION TEST DATA**

Test Site: 1# Shielded Room  
 Operating Condition: Playing video+HDMI output+Internet connect mode  
 Test Specification: AC 240V, 60Hz for adapter  
 Comment: Neutral Line  
 Tem.:25°C Hum.:50%

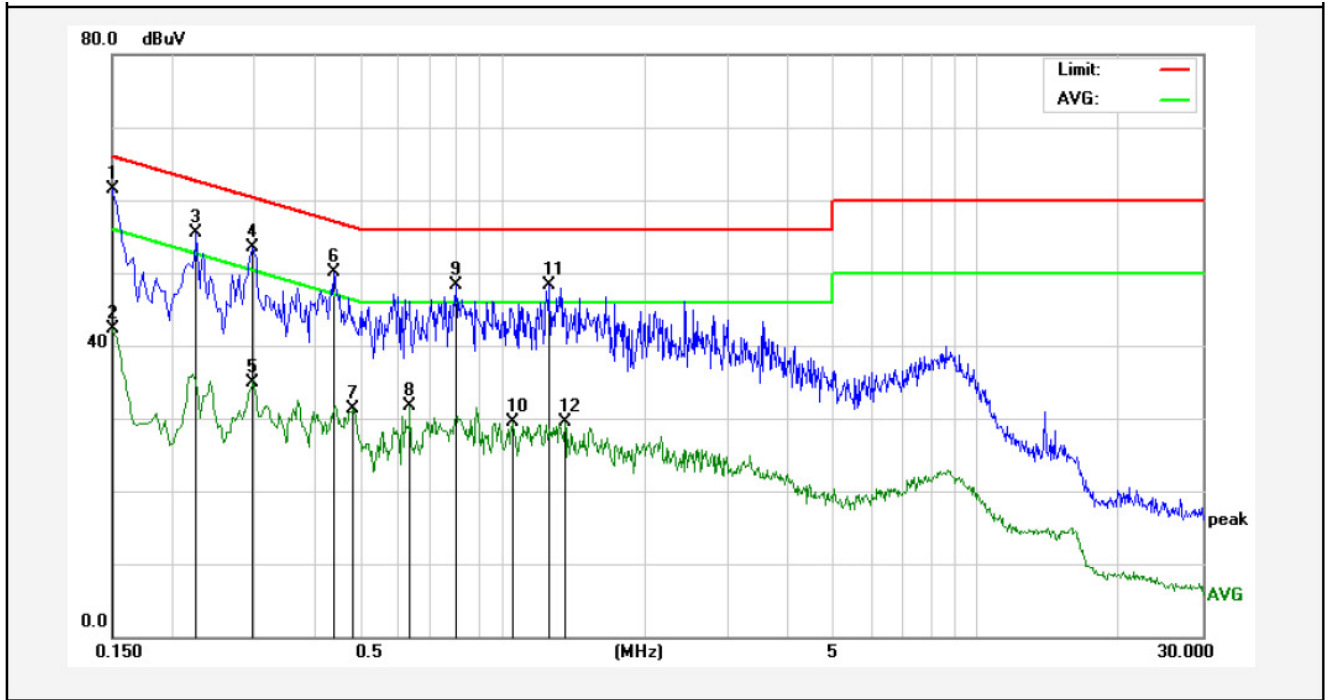

No.	Freq. (MHz)	Reading (dBuV)	Factor (dB)	Result (dBuV)	Limit (dBuV)	Over Limit (dB)	Detector	Remark
1	0.1499	41.52	19.91	61.43	66.00	-4.57	QP	
2	0.1499	22.28	19.91	42.19	56.00	-13.81	AVG	
3	0.2260	35.49	19.89	55.38	52.59	2.79	QP	
4	0.2980	33.41	19.89	53.30	60.30	-7.00	QP	
5	0.2980	15.00	19.89	34.89	50.30	-15.41	AVG	
6	0.4420	30.01	19.91	49.92	57.02	-7.10	QP	
7	0.4860	11.28	19.95	31.23	46.24	-15.01	AVG	
8	0.6380	11.68	20.01	31.69	46.00	-14.31	AVG	
9	0.7980	28.23	20.05	48.28	56.00	-7.72	QP	
10	1.0540	9.57	20.12	29.69	46.00	-16.31	AVG	
11	1.2579	28.35	20.13	48.48	56.00	-7.52	QP	
12	1.3580	9.46	20.13	29.59	46.00	-16.41	AVG	

## 4. Bandwidth

### 4.1. Test Limit

The maximum power spectral density is measured as a conducted emission by direct connection of a calibrated test instrument to the equipment under test. If the device cannot be connected directly, alternative techniques acceptable to the Commission may be used. Measurements in the 5.725-5.85 GHz band are made over a reference bandwidth of 500 kHz or the 26 dB emission bandwidth of the device, whichever is less. Measurements in the 5.15-5.25 GHz, 5.25-5.35 GHz, and the 5.47-5.725 GHz bands are made over a bandwidth of 1 MHz or the 26 dB emission bandwidth of the device, whichever is less. A narrower resolution bandwidth can be used, provided that the measured power is integrated over the full reference bandwidth.

Within the 5.725-5.85 GHz band, the minimum 6 dB bandwidth of U-NII devices shall be at least 500 kHz.

### 4.2. Test Setup

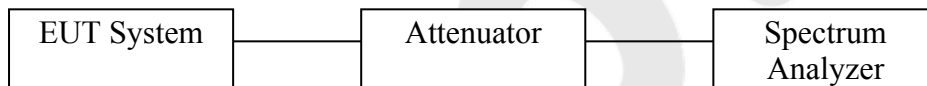

### 4.3. Test Procedure

1. Place the EUT on the table and set it in the transmitting mode.
2. Remove the antenna from the EUT and then connect a low loss RF cable from the antenna port to the spectrum analyzer.
3. Set the spectrum analyzer as:
  - 26 dB & 99% bandwidth**
  - RBW = approximately 1% of the emission bandwidth;
  - Set the VBW > RBW;
  - Detector= Peak
  - Trace mode= Max hold.
  - Sweep- auto couple.
  - 6 dB bandwidth**
  - RBW = 100kHz;
  - Set the video bandwidth (VBW)  $\geq 3$  RBW ;
  - Detector= Peak
  - Trace mode= Max hold.
  - Sweep- auto couple.

4. Measure the maximum width of the emission that is 26dB /6dB down from the maximum of the emission. Compare this with the RBW setting of the analyzer.
5. Repeat until all the rest channels are investigated.

#### 4.4. Test Equipment

Item	Equipment	Manufacturer	Model No.	Serial No.	Last Cal.	Cal. Interval
1.	Spectrum Analysis	Agilent	E4407B	US39390582	Apr. 16, 2016	1 Year
2.	Preamplifier	Instruments corporation	EMC011830	980100	Apr. 16, 2016	1 Year
3.	EMI Test Receiver	Rohde & Schwarz	ESPI	101604	Apr. 16, 2016	1 Year
4.	Double Ridged Horn Antenna	Instruments corporation	GTH-0118	351600	Apr. 19, 2016	1 Year
5.	Bilog Broadband Antenna	Schwarzbeck	VULB9163	VULB 9163-289	Apr. 19, 2016	1 Year
6.	Pre-amplifier	SONOMA	310N	186860	Apr. 16, 2016	1 Year
7.	EMI Test Software EZ-EMC	SHURPLE	N/A	N/A	N/A	N/A
8	Power Sensor	DAER	RPR3006W	15I00041SN046	Jun 30, 2016	1 Year
9	MXA Spectrum Analysis	Agilent	N9020A	MY51170037	Jun 30, 2016	1 Year
10	MXG RF Vector Signal Generator	Agilent	N5182A	MY48180656	Jun 30, 2016	1 Year
11	Signal Generator	Agilent	E4421B	MY41000743	Jun 30, 2016	1 Year
12	DC Power supply	IV	IV-8080	YQSB0096	Jun 30, 2016	1 Year
13	TEMP&HUMI PROGRAMMABLE CHAMBER	Bell Group	BE-THK-150M8	SE-0137	Mar. 16, 2016	1 Year

#### 4.5. Test Results

Pass.

Please refer to the following data.

**Bandwidth:**

Test mode: IEEE 802.11n(HT20)

Channel	Frequency (MHz)	6dB Bandwidth (MHz)	26dB Bandwidth (MHz)	99% Bandwidth (MHz)
Low	5180	17.65	21.97	17.877
Mid	5200	17.63	22.36	17.960
High	5240	17.57	21.38	17.837
Channel	Frequency (MHz)	6dB Bandwidth (MHz)	26dB Bandwidth (MHz)	99% Bandwidth (MHz)
Low	5745	15.86	23.78	18.049
Mid	5785	16.49	23.09	18.504
High	5825	16.28	20.23	17.955

Test mode: IEEE 802.11n(HT40)

Channel	Frequency (MHz)	6dB Bandwidth (MHz)	26dB Bandwidth (MHz)	99% Bandwidth (MHz)
Low	5190	35.39	42.84	36.376
High	5230	26.26	42.82	36.367
Channel	Frequency (MHz)	6dB Bandwidth (MHz)	26dB Bandwidth (MHz)	99% Bandwidth (MHz)
Low	5755	35.56	39.65	36.266
High	5795	35.86	40.12	36.417

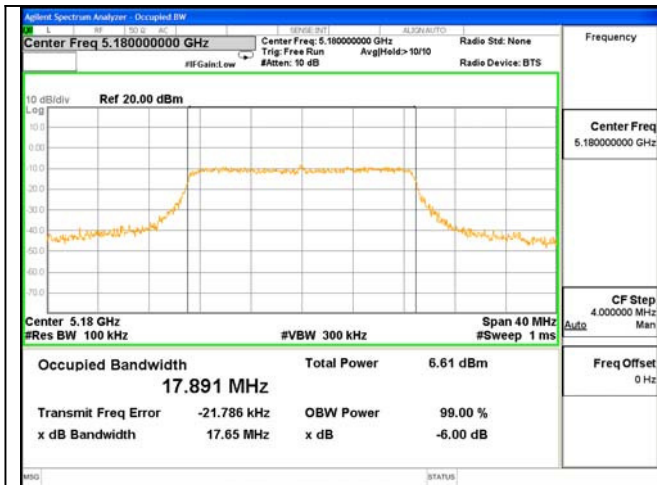

6dB Bandwidth  
Test Mode: 802.11n(HT20)--5180

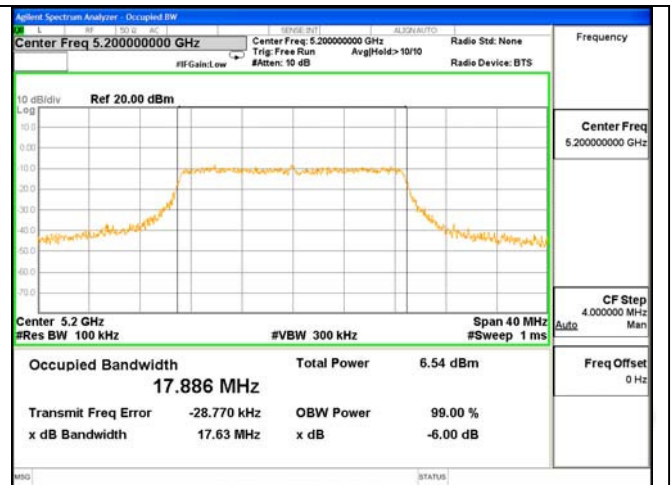

6dB Bandwidth  
Test Mode: 802.11n(HT20)---5200

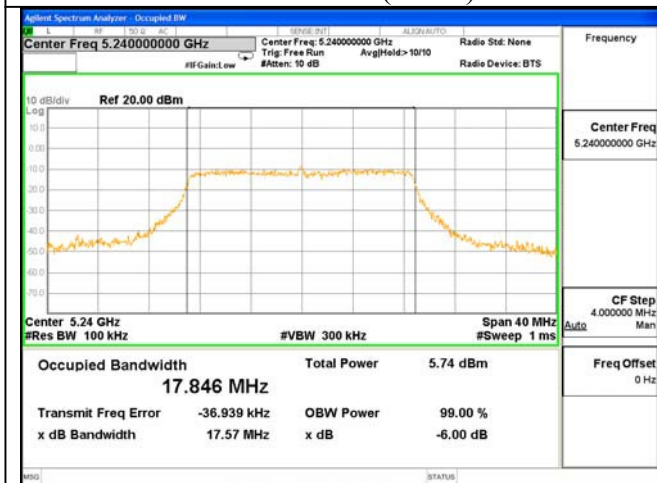

6dB Bandwidth  
Test Mode: 802.11n(HT20)--5240

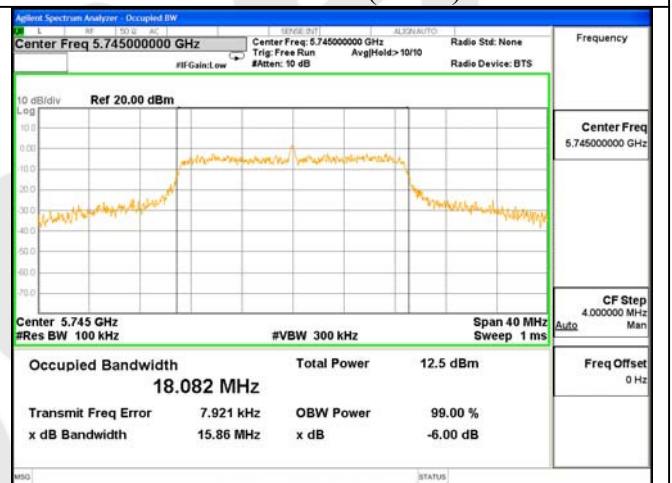

6dB Bandwidth  
Test Mode: 802.11n(HT20)---5745

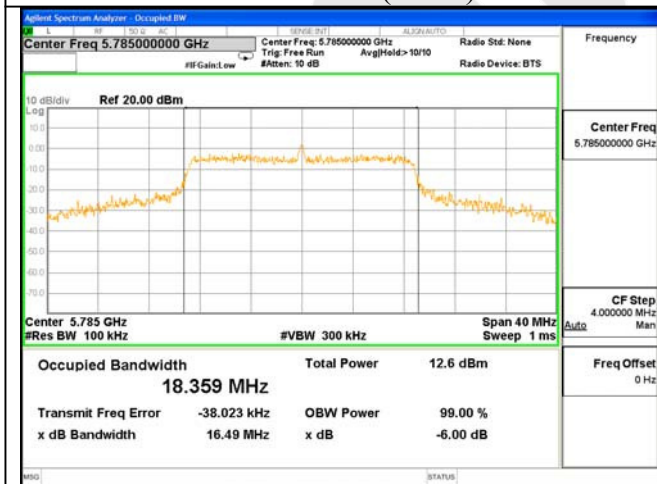

6dB Bandwidth  
Test Mode: 802.11n(HT20)--5785

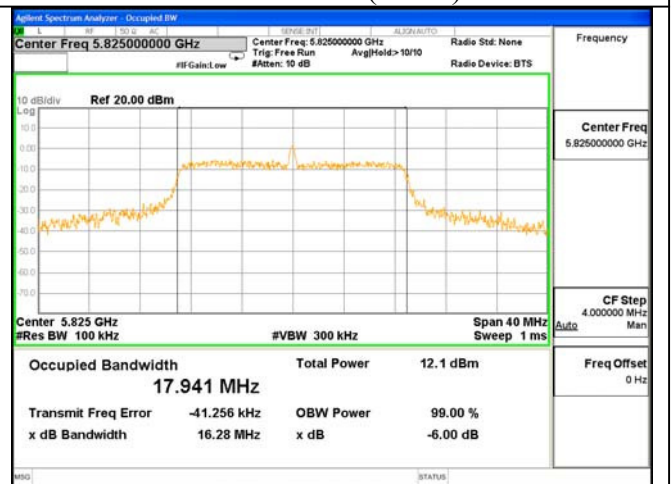

6dB Bandwidth  
Test Mode: 802.11n(HT20)---5825

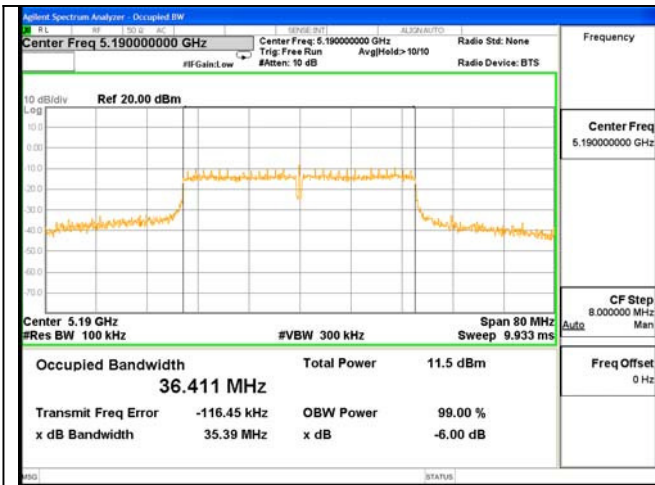

6dB Bandwidth  
Test Mode: 802.11n(HT40)--5190

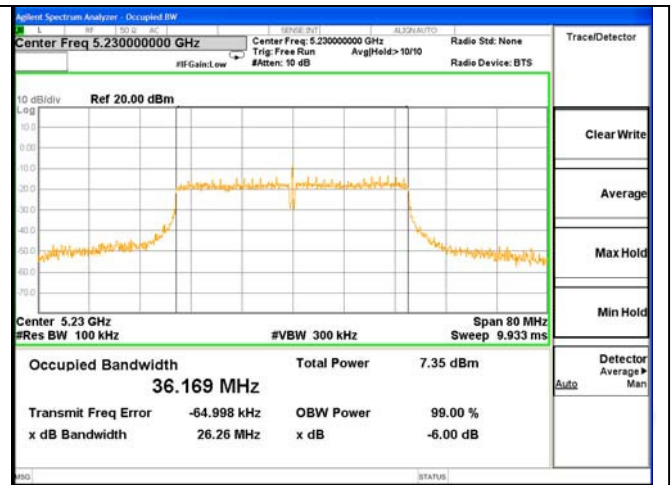

6dB Bandwidth  
Test Mode: 802.11n(HT40)---5230

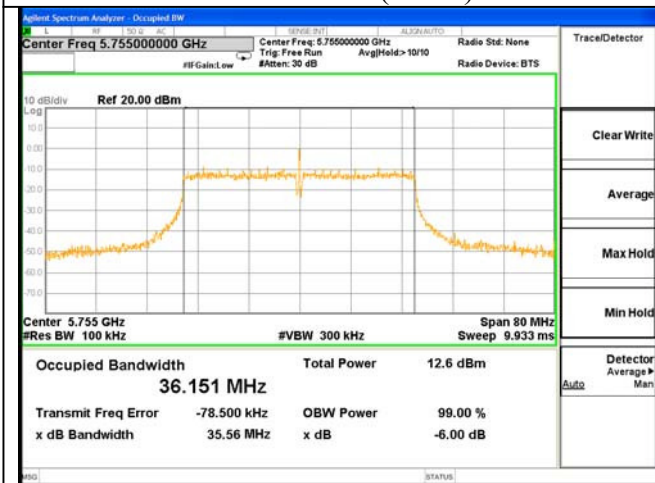

6dB Bandwidth  
Test Mode: 802.11n(HT40)--5755

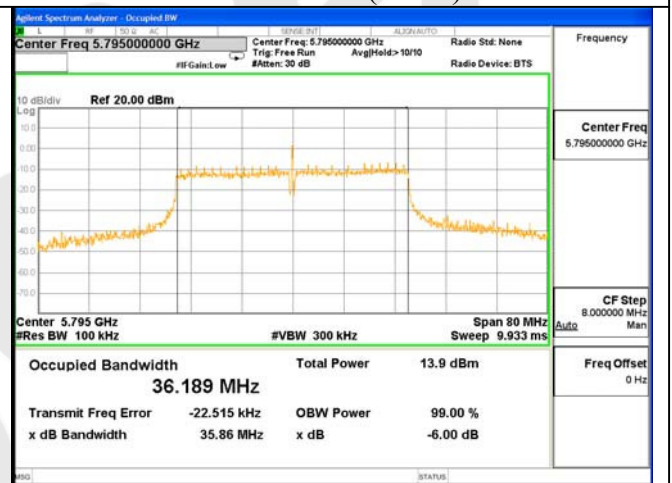

6dB Bandwidth  
Test Mode: 802.11n(HT40)---5795



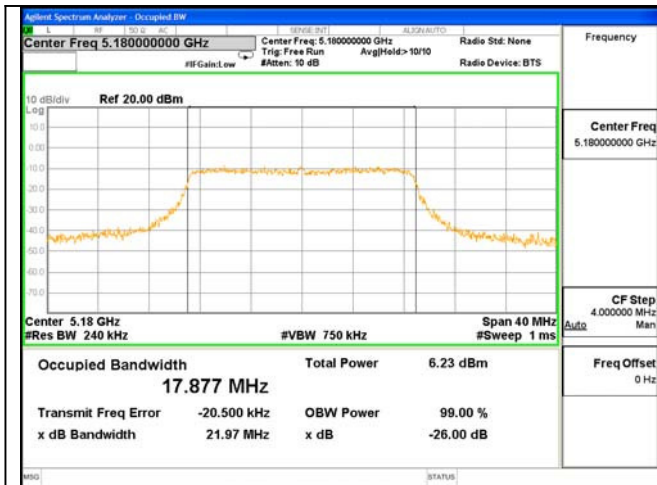

26dB & 99% Bandwidth  
Test Mode: 802.11n(HT20)--5180

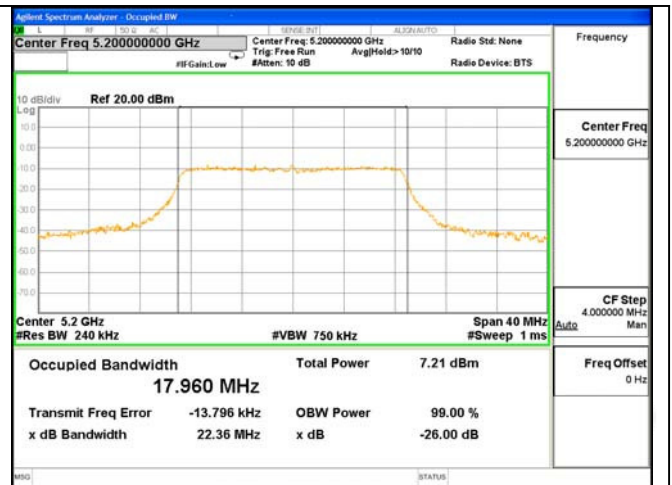

26dB & 99% Bandwidth  
Test Mode: 802.11n(HT20)---5200

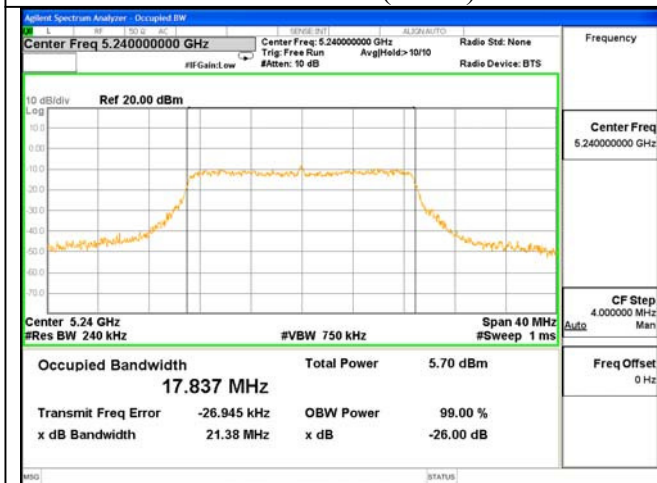

26dB & 99% Bandwidth  
Test Mode: 802.11n(HT20)--5240

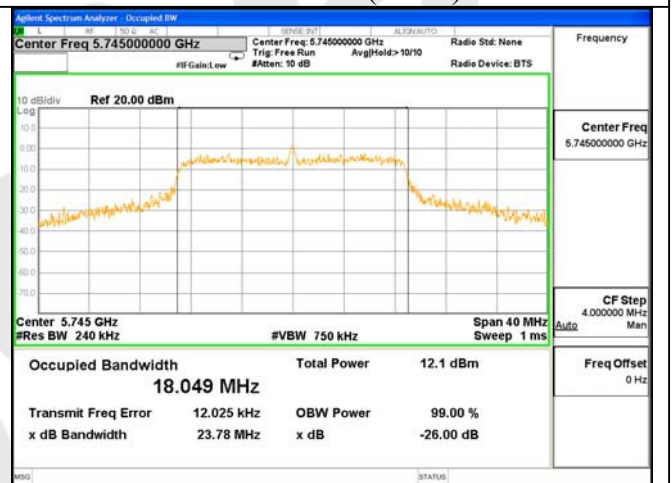

26dB & 99% Bandwidth  
Test Mode: 802.11n(HT20)---5745

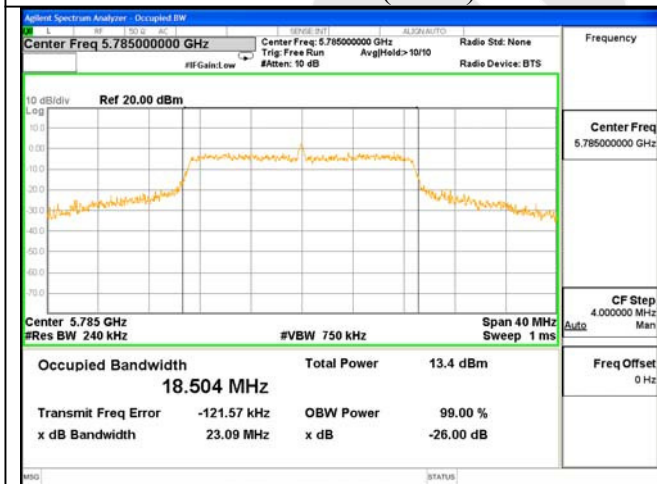

26dB & 99% Bandwidth  
Test Mode: 802.11n(HT20)--5785

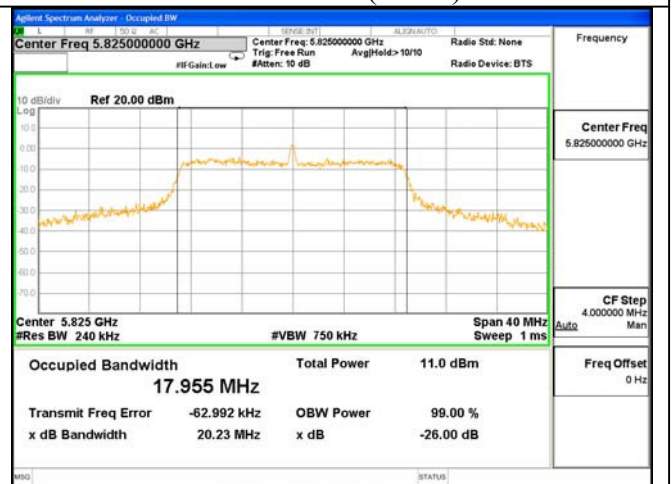

26dB & 99% Bandwidth  
Test Mode: 802.11n(HT20)---5825

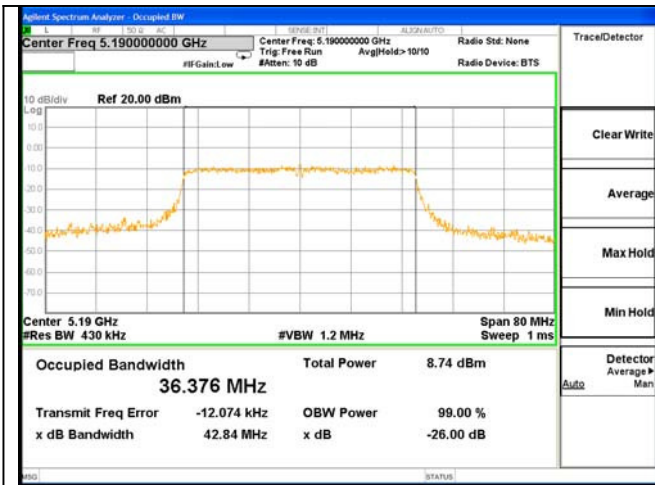

26dB & 99% Bandwidth  
Test Mode: 802.11n(HT40)--5190

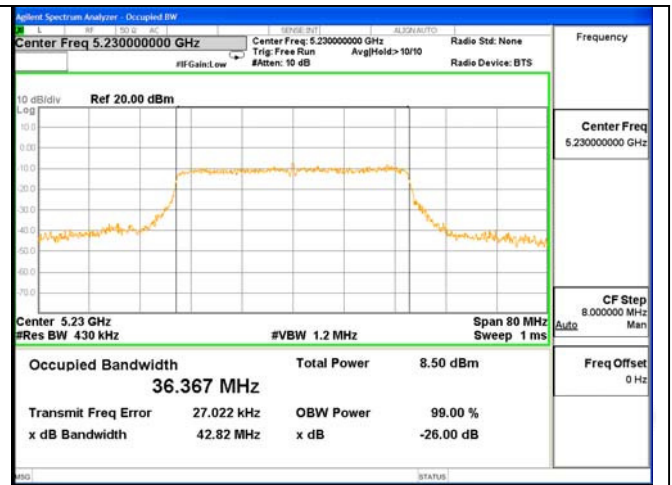

26dB & 99% Bandwidth  
Test Mode: 802.11n(HT40)---5230

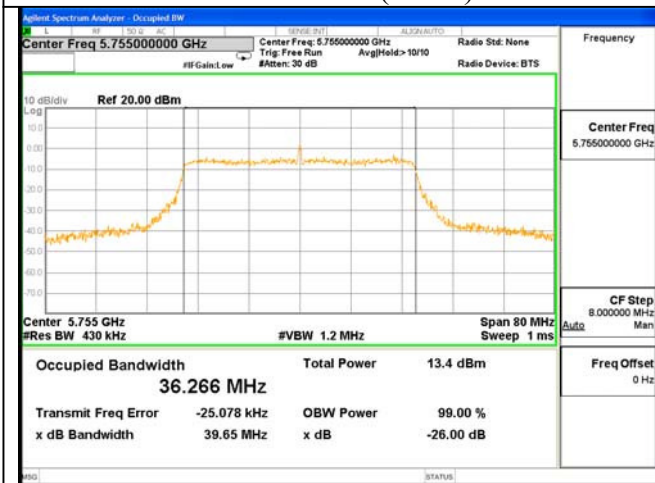

26dB & 99% Bandwidth  
Test Mode: 802.11n(HT40)--5755

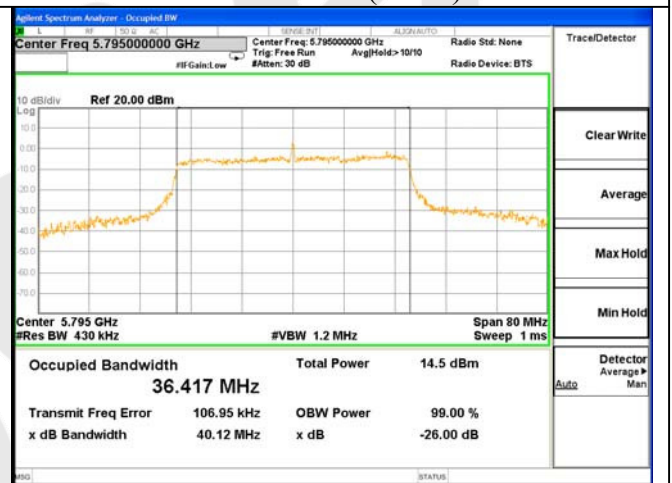

26dB & 99% Bandwidth  
Test Mode: 802.11n(HT40)---5795



Test mode: IEEE 802.11AC(HT20)

Channel	Frequency (MHz)	6dB Bandwidth (MHz)	26dB Bandwidth (MHz)	99% Bandwidth (MHz)
Low	5180	16.37	22.62	16.767
Mid	5200	16.39	22.86	16.777
High	5240	16.33	21.97	16.652
Channel	Frequency (MHz)	6dB Bandwidth (MHz)	26dB Bandwidth (MHz)	99% Bandwidth (MHz)
Low	5745	16.07	20.09	16.868
Mid	5785	15.96	20.64	16.934
High	5825	16.32	19.36	16.747

Test mode: IEEE 802.11AC(HT40)

Channel	Frequency (MHz)	6dB Bandwidth (MHz)	26dB Bandwidth (MHz)	99% Bandwidth (MHz)
Low	5190	36.40	42.62	38.282
High	5230	36.35	42.53	36.977
Channel	Frequency (MHz)	6dB Bandwidth (MHz)	26dB Bandwidth (MHz)	99% Bandwidth (MHz)
Low	5755	35.54	41.95	36.511
High	5795	35.59	42.50	36.967

Test mode: IEEE 802.11AC(HT80)

Frequency (MHz)	6dB Bandwidth (MHz)	26dB Bandwidth (MHz)	99% Bandwidth (MHz)
5210	63.44	82.94	75.529
Frequency (MHz)	6dB Bandwidth (MHz)	26dB Bandwidth (MHz)	99% Bandwidth (MHz)
5755	64.33	76.64	75.521

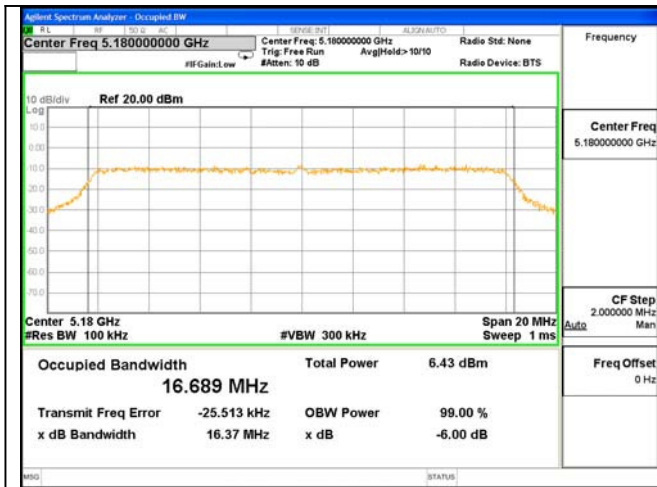

6dB Bandwidth  
Test Mode: 802.11AC(20)--5180

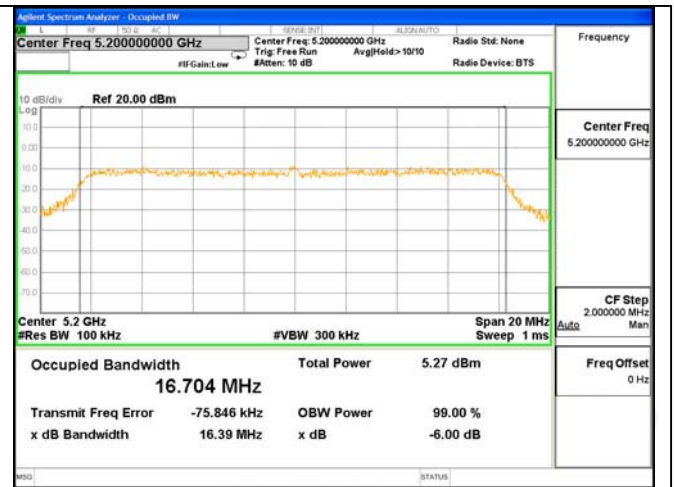

6dB Bandwidth  
Test Mode: 802.11AC(20)---5200

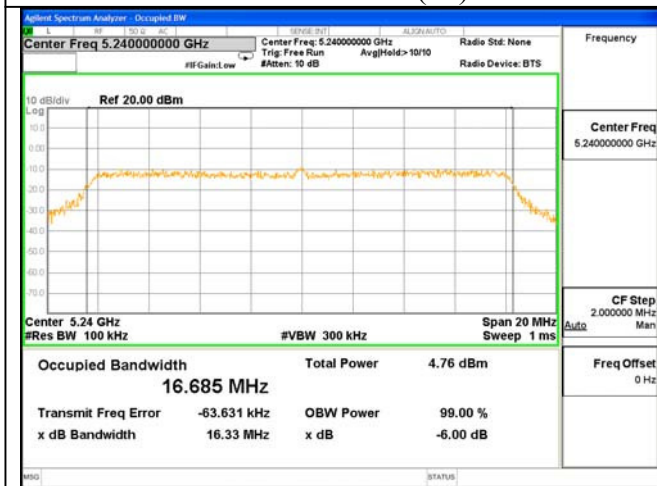

6dB Bandwidth  
Test Mode: 802.11AC(20)--5240

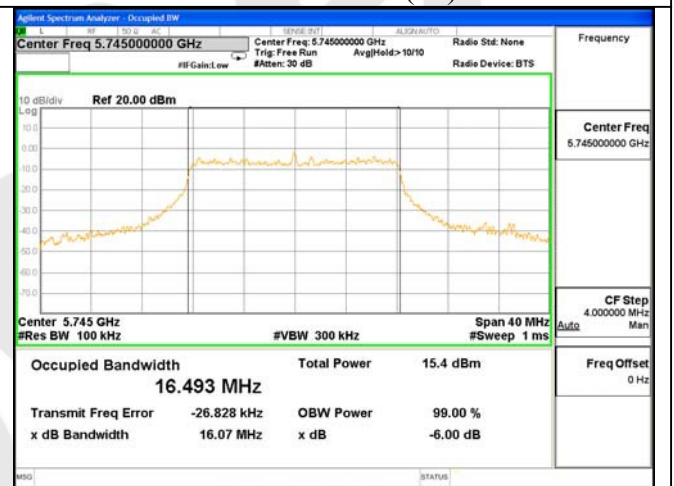

6dB Bandwidth  
Test Mode: 802.11AC(20)---5745

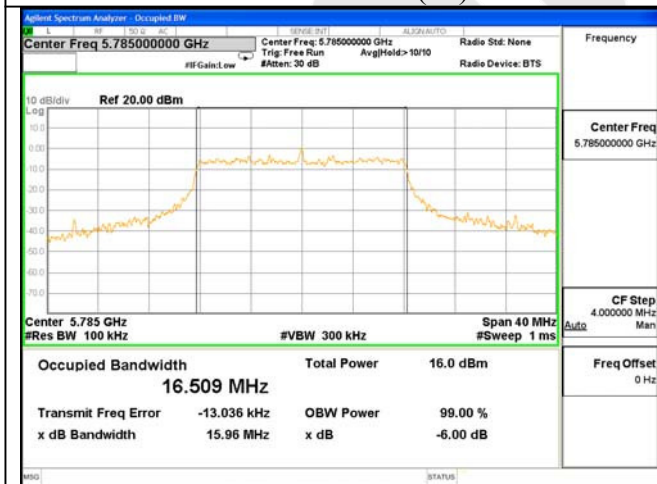

6dB Bandwidth  
Test Mode: 802.11AC(20)--5785

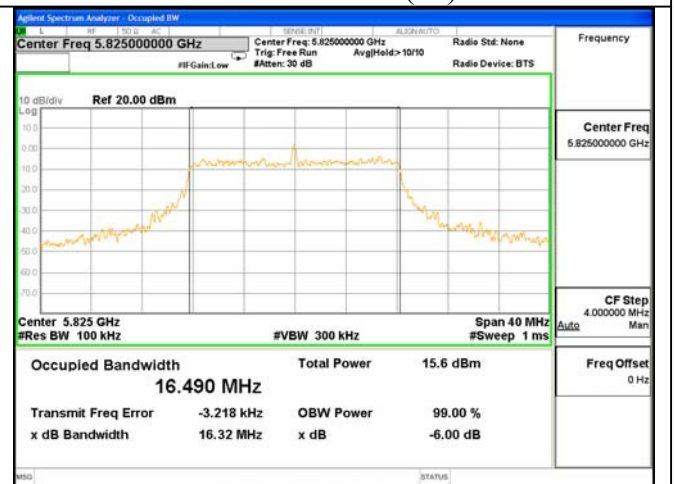

6dB Bandwidth  
Test Mode: 802.11AC(20)---5825

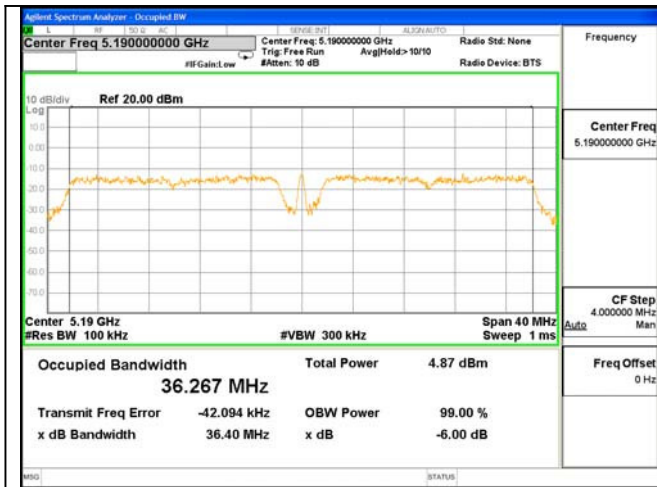

6dB Bandwidth  
Test Mode: 802.11AC(40)--5190

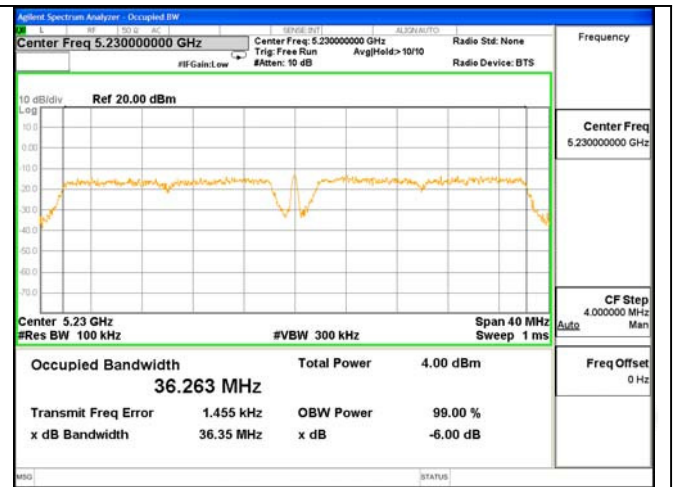

6dB Bandwidth  
Test Mode: 802.11AC(40)---5230

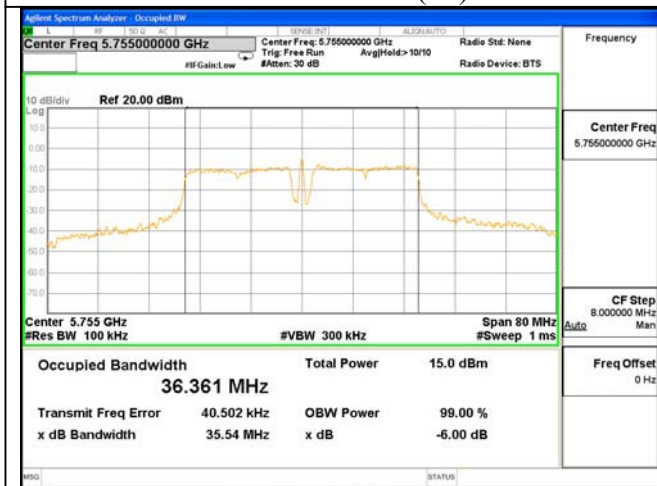

6dB Bandwidth  
Test Mode: 802.11AC(40)--5755

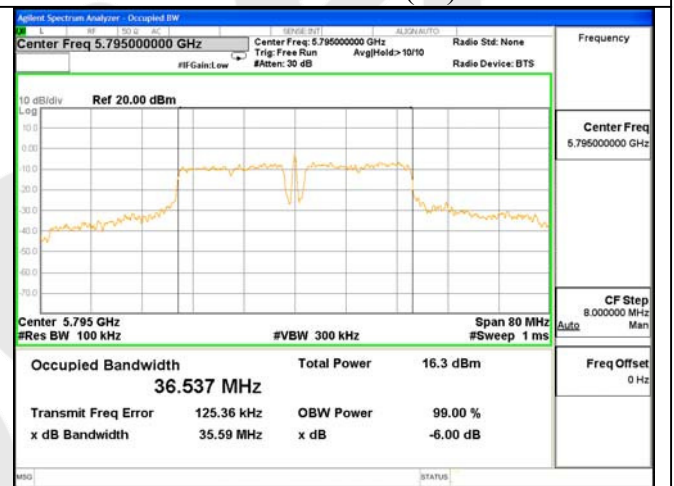

6dB Bandwidth  
Test Mode: 802.11AC(40)---5795

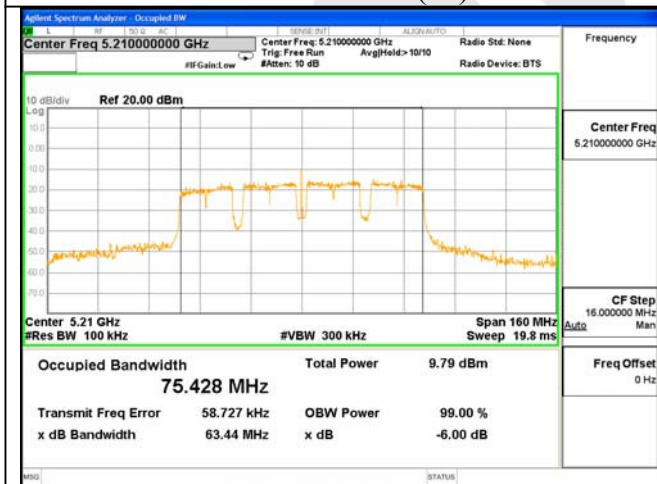

6dB Bandwidth  
Test Mode: 802.11AC(80)--5210

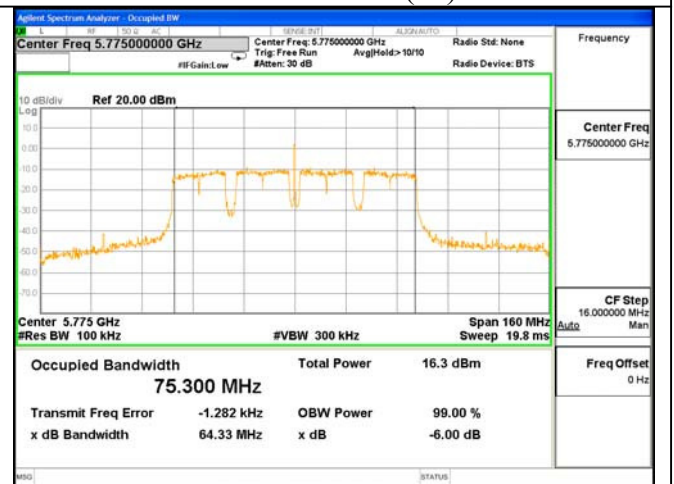

6dB Bandwidth  
Test Mode: 802.11AC(80)---5755

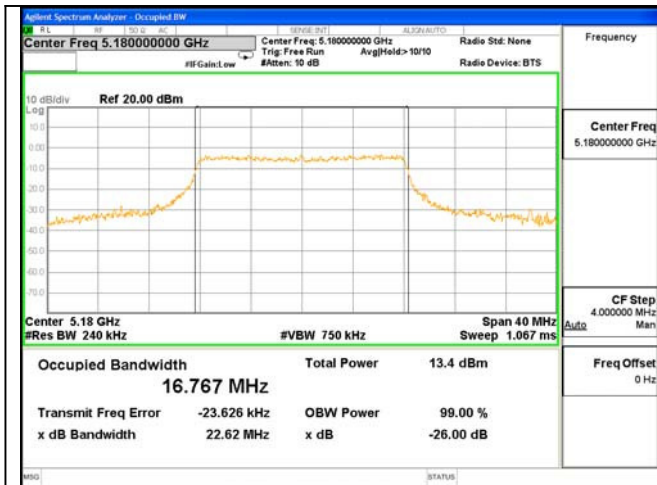

26dB & 99% Bandwidth  
Test Mode: 802.11AC(20)--5180

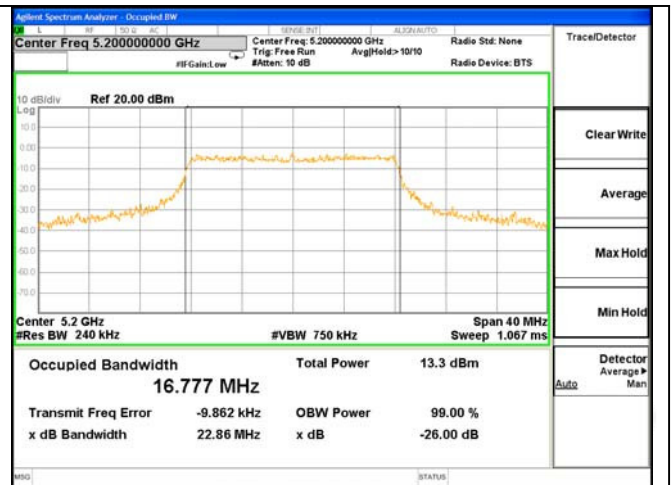

26dB & 99% Bandwidth  
Test Mode: 802.11AC(20)---5200

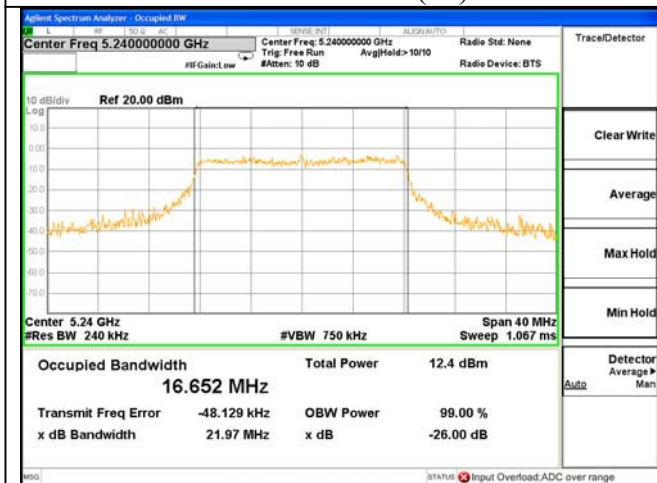

26dB & 99% Bandwidth  
Test Mode: 802.11AC(20)--5240

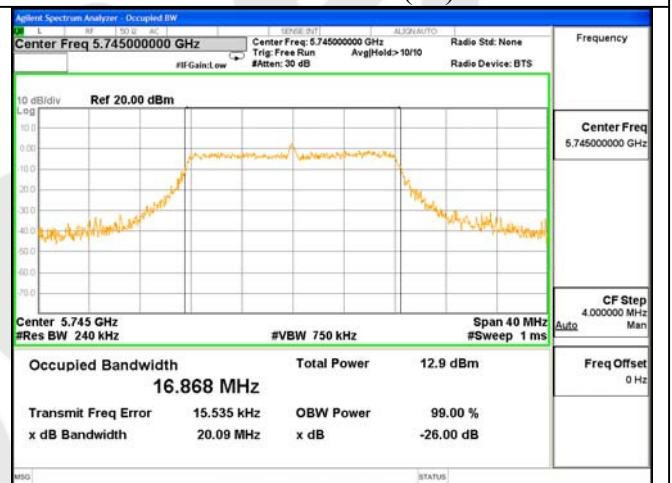

26dB & 99% Bandwidth  
Test Mode: 802.11AC(20)---5745

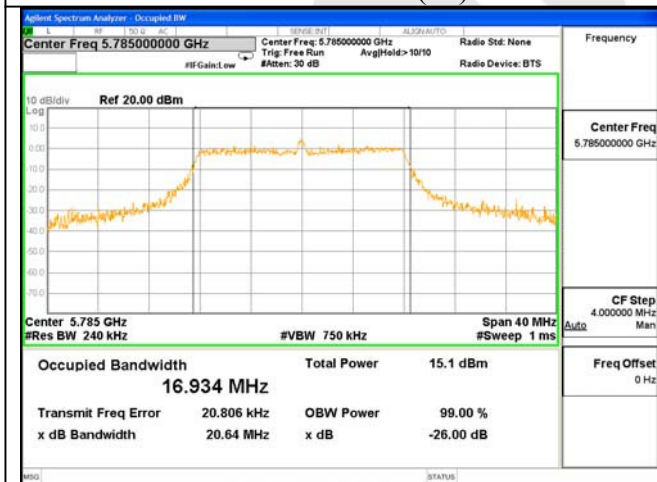

26dB & 99% Bandwidth  
Test Mode: 802.11AC(20)--5785

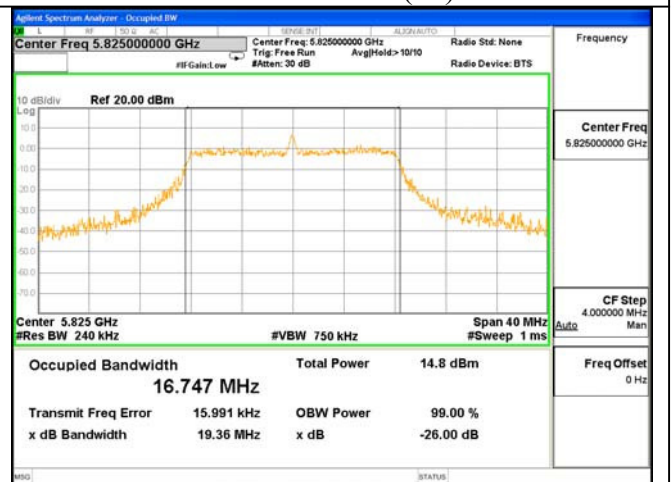

26dB & 99% Bandwidth  
Test Mode: 802.11AC(20)---5825



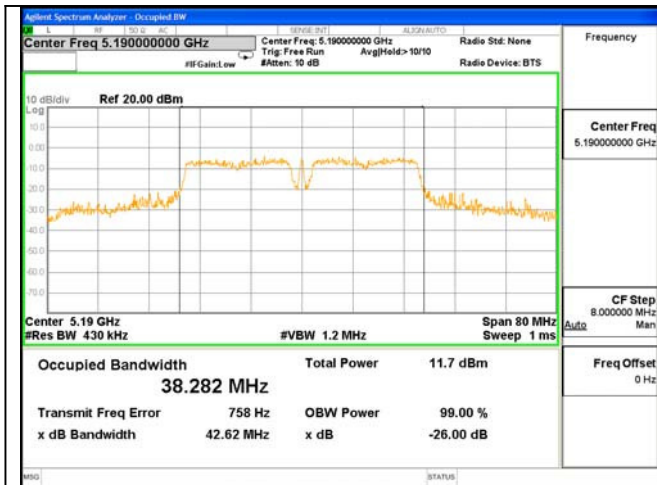

26dB & 99% Bandwidth  
Test Mode: 802.11AC(40)--5190

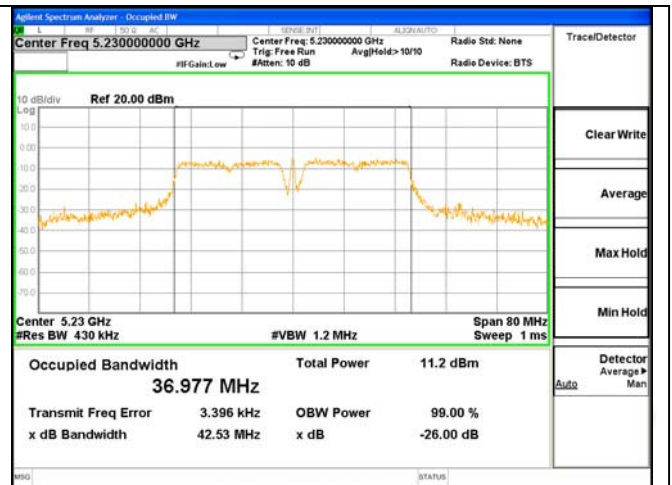

26dB & 99% Bandwidth  
Test Mode: 802.11AC(40)---5230

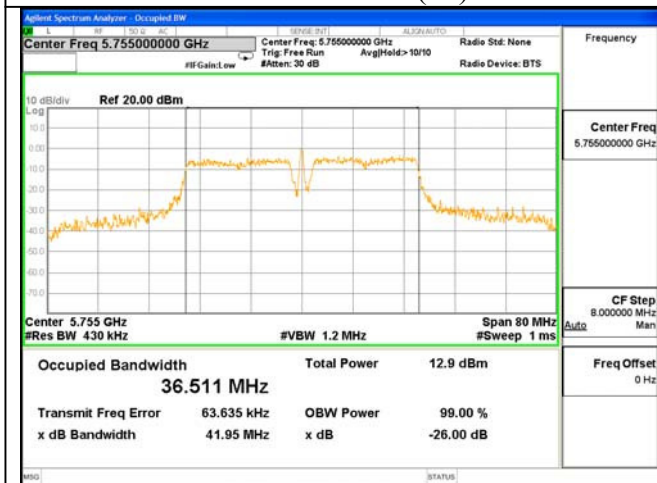

26dB & 99% Bandwidth  
Test Mode: 802.11AC(40)--5755

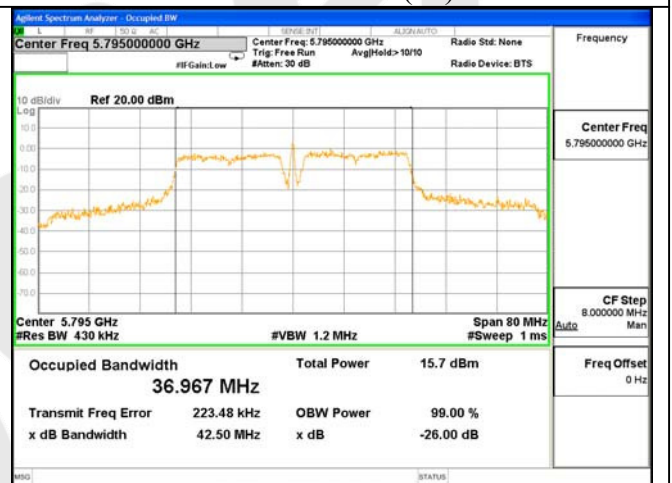

26dB & 99% Bandwidth  
Test Mode: 802.11AC(40)---5795

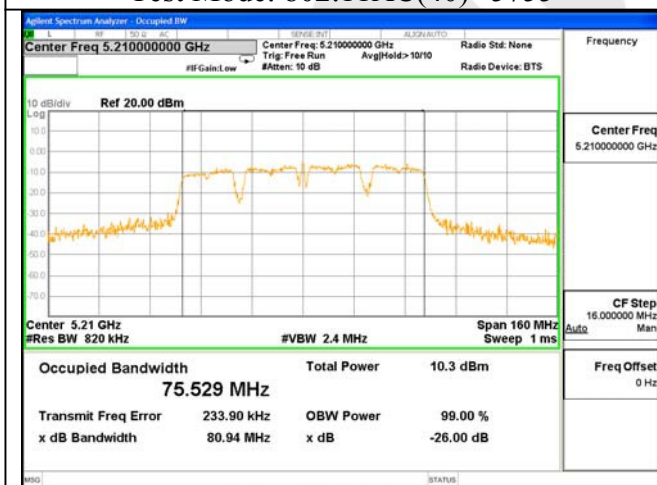

26dB & 99% Bandwidth  
Test Mode: 802.11AC(80)--5210

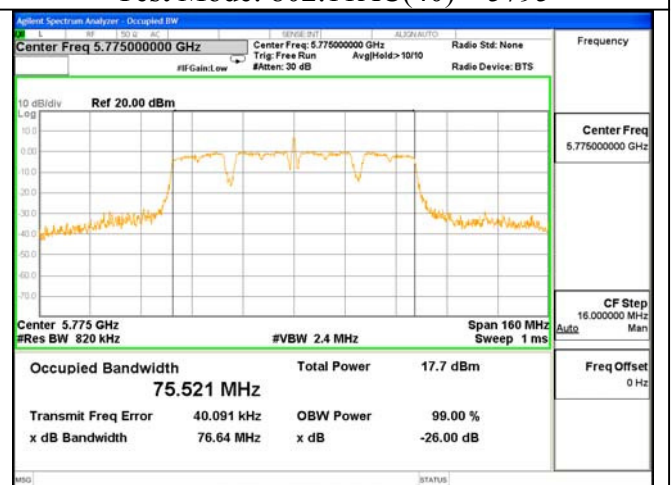

26dB & 99% Bandwidth  
Test Mode: 802.11AC(80)---5775

## 5. Maximum Conducted Output Power Test

### 5.1. Test Limit

1) For the band 5.15-5.25 GHz.

(i) For an outdoor access point operating in the band 5.15-5.25 GHz, the maximum conducted output power over the frequency band of operation shall not exceed 1 W provided the maximum antenna gain does not exceed 6 dBi. In addition, the maximum power spectral density shall not exceed 17 dBm in any 1 megahertz band. If transmitting antennas of directional gain greater than 6 dBi are used, both the maximum conducted output power and the maximum power spectral density shall be reduced by the amount in dB that the directional gain of the antenna exceeds 6 dBi. The maximum e.i.r.p. at any elevation angle above 30 degrees as measured from the horizon must not exceed 125 mW (21 dBm).

(ii) For an indoor access point operating in the band 5.15-5.25 GHz, the maximum conducted output power over the frequency band of operation shall not exceed 1 W provided the maximum antenna gain does not exceed 6 dBi. In addition, the maximum power spectral density shall not exceed 17 dBm in any 1 megahertz band. If transmitting antennas of directional gain greater than 6 dBi are used, both the maximum conducted output power and the maximum power spectral density shall be reduced by the amount in dB that the directional gain of the antenna exceeds 6 dBi.

(iii) For fixed point-to-point access points operating in the band 5.15-5.25 GHz, the maximum conducted output power over the frequency band of operation shall not exceed 1 W. In addition, the maximum power spectral density shall not exceed 17 dBm in any 1 megahertz band. Fixed point-to-point U-NII devices may employ antennas with directional gain up to 23 dBi without any corresponding reduction in the maximum conducted output power or maximum power spectral density. For fixed point-to-point transmitters that employ a directional antenna gain greater than 23 dBi, a 1 dB reduction in maximum conducted output power and maximum power spectral density is required for each 1 dB of antenna gain in excess of 23 dBi. Fixed, point-to-point operations exclude the use of point-to-multipoint systems, omnidirectional applications, and multiple collocated transmitters transmitting the same information. The operator of the U-NII device, or if the equipment is professionally installed, the installer, is responsible for ensuring that systems employing high gain directional antennas are used exclusively for fixed, point-to-point operations.

(iv) For mobile and portable client devices in the 5.15-5.25 GHz band, the maximum conducted output power over the frequency band of operation shall not exceed 250 mW provided the maximum antenna gain does not exceed 6 dBi. In addition, the maximum power spectral density shall not exceed 11 dBm in any 1 megahertz band. If transmitting antennas of directional gain greater than 6 dBi are used, both the maximum conducted output power and the maximum power spectral density shall be reduced by the amount in dB that the directional gain of the antenna exceeds 6 dBi.

(2) For the 5.25-5.35 GHz and 5.47-5.725 GHz bands, the maximum conducted output power over the frequency bands of operation shall not exceed the lesser of 250 mW or  $11 \text{ dBm} + 10 \log B$ , where B is the 26 dB emission bandwidth in megahertz. In addition, the maximum power spectral density shall not exceed 11 dBm in any 1 megahertz band. If transmitting antennas of directional

gain greater than 6 dBi are used, both the maximum conducted output power and the maximum power spectral density shall be reduced by the amount in dB that the directional gain of the antenna exceeds 6 dBi.

(3) For the band 5.725-5.85 GHz, the maximum conducted output power over the frequency band of operation shall not exceed 1 W. In addition, the maximum power spectral density shall not exceed 30 dBm in any 500-kHz band. If transmitting antennas of directional gain greater than 6 dBi are used, both the maximum conducted output power and the maximum power spectral density shall be reduced by the amount in dB that the directional gain of the antenna exceeds 6 dBi. However, fixed point-to-point U-NII devices operating in this band may employ transmitting antennas with directional gain greater than 6 dBi without any corresponding reduction in transmitter conducted power. Fixed, point-to-point operations exclude the use of point-to-multipoint systems, omnidirectional applications, and multiple collocated transmitters transmitting the same information. The operator of the U-NII device, or if the equipment is professionally installed, the installer, is responsible for ensuring that systems employing high gain directional antennas are used exclusively for fixed, point-to-point operations.

## 5.2. Test Setup

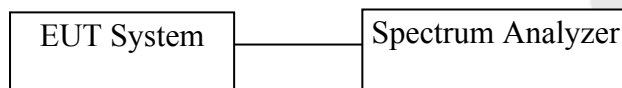

## 5.3. Test Procedure

1. Set span to encompass the entire emission bandwidth (EBW) (or, alternatively, the entire 99% occupied bandwidth) of the signal.
2. Set RBW = 1 MHz.
3. Set VBW  $\geq$  3 MHz.
4. Number of points in sweep  $\geq 2 \times \text{span} / \text{RBW}$ . (This ensures that bin-to-bin spacing is  $\leq \text{RBW}/2$ , so that narrowband signals are not lost between frequency bins.)
5. Sweep time = auto.
6. Detector = power averaging (rms), if available. Otherwise, use sample detector mode.
7. If transmit duty cycle  $< 98\%$ , use a video trigger with the trigger level set to enable triggering only on full power pulses. Transmitter must operate at maximum power control level for the entire duration of every sweep. If the EUT transmits continuously (i.e., with no off intervals) or at duty cycle  $\geq 98\%$ , and if each transmission is entirely at the maximum power control level, then the trigger shall be set to “free run.”
8. Trace average at least 100 traces in power averaging (rms) mode.
9. Compute power by integrating the spectrum across the EBW (or, alternatively, the entire 99% occupied bandwidth) of the signal using the instrument’s band power measurement function with band limits set equal to the EBW (or occupied bandwidth) band edges. If the instrument does not have a band power function, sum the spectrum levels (in power units) at 1 MHz intervals extending across the EBW (or, alternatively, the entire 99% occupied bandwidth) of the spectrum.

#### 5.4. Test Equipment

Item	Equipment	Manufacturer	Model No.	Serial No.	Last Cal.	Cal. Interval
1.	Spectrum Analysis	Agilent	E4407B	US39390582	Apr. 16, 2016	1 Year
2.	Preamplifier	Instruments corporation	EMC011830	980100	Apr. 16, 2016	1 Year
3.	EMI Test Receiver	Rohde & Schwarz	ESPI	101604	Apr. 16, 2016	1 Year
4.	Double Ridged Horn Antenna	Instruments corporation	GTH-0118	351600	Apr. 19, 2016	1 Year
5.	Bilog Broadband Antenna	Schwarzbeck	VULB9163	VULB 9163-289	Apr. 19, 2016	1 Year
6.	Pre-amplifier	SONOMA	310N	186860	Apr. 16, 2016	1 Year
7.	EMI Test Software EZ-EMC	SHURPLE	N/A	N/A	N/A	N/A
8	Power Sensor	DAER	RPR3006W	15I00041SN046	Jun 30, 2016	1 Year
9	MXA Spectrum Analysis	Agilent	N9020A	MY51170037	Jun 30, 2016	1 Year
10	MXG RF Vector Signal Generator	Agilent	N5182A	MY48180656	Jun 30, 2016	1 Year
11	Signal Generator	Agilent	E4421B	MY41000743	Jun 30, 2016	1 Year
12	DC Power supply	IV	IV-8080	YQSB0096	Jun 30, 2016	1 Year
13	TEMP&HUMI PROGRAMMABLE CHAMBER	Bell Group	BE-THK-150M8	SE-0137	Mar. 16, 2016	1 Year



### 5.5. Test Results

Pass.

Please refer to the following data.

Test mode: IEEE 802.11n(HT20)

Channel	Frequency (MHz)	Maximum transmit power (dBm)	Limit (dBm)	Result
Low	5180	17.53	24	Pass
Mid	5200	16.81	24	Pass
High	5240	15.84	24	Pass
Low	5745	12.92	30	Pass
Mid	5785	15.13	30	Pass
High	5825	15.76	30	Pass

Test mode: IEEE 802.11n(HT40)

Channel	Frequency (MHz)	Maximum transmit power (dBm)	Limit (dBm)	Result
Low	5190	13.07	24	Pass
High	5230	13.81	24	Pass
Low	5755	17.18	30	Pass
High	5795	17.19	30	Pass



Test Mode: 802.11n(HT20)---5180



Test Mode: 802.11n(HT20)---5200

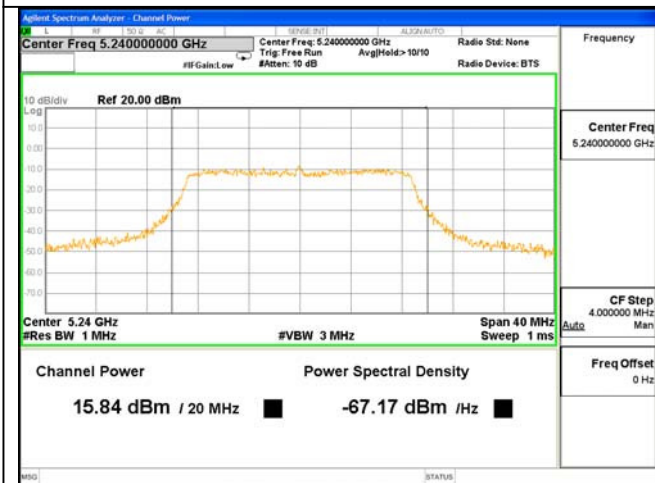

Test Mode: 802.11n(HT20)---5240

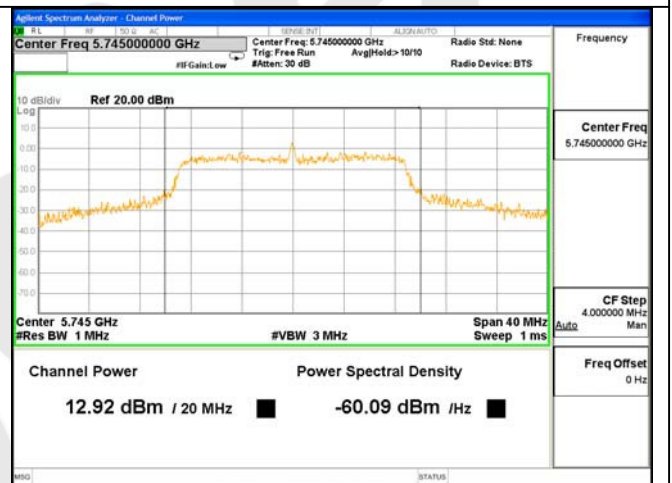

Test Mode: 802.11n(HT20)---5745

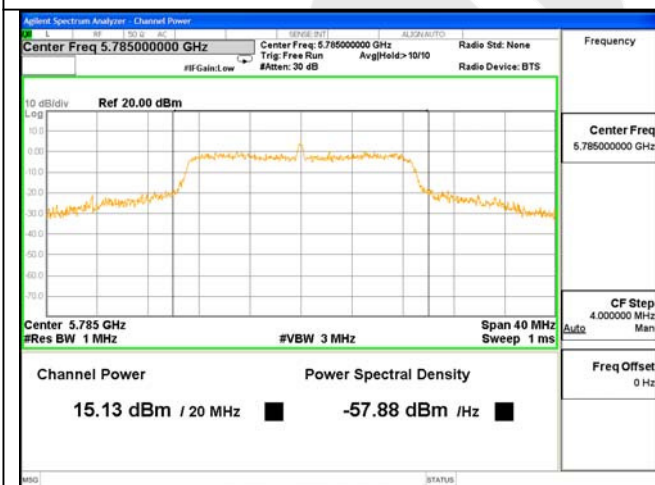

Test Mode: 802.11n(HT20)---5785

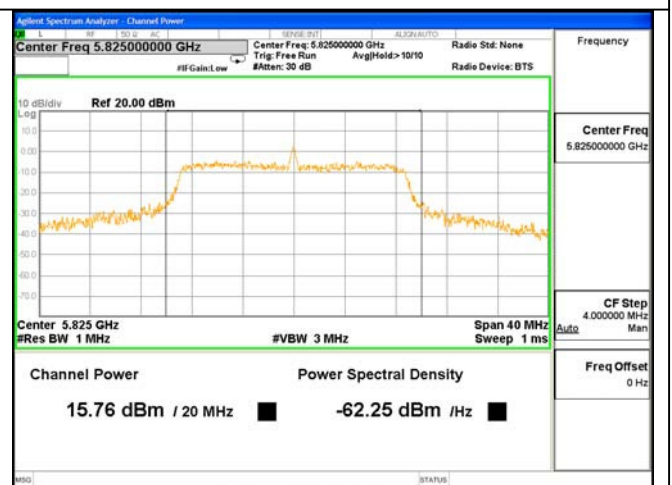

Test Mode: 802.11n(HT20)---5825



Test Mode: 802.11n(HT40)---5190



Test Mode: 802.11n(HT40)---5230



Test Mode: 802.11n(HT40)---5755

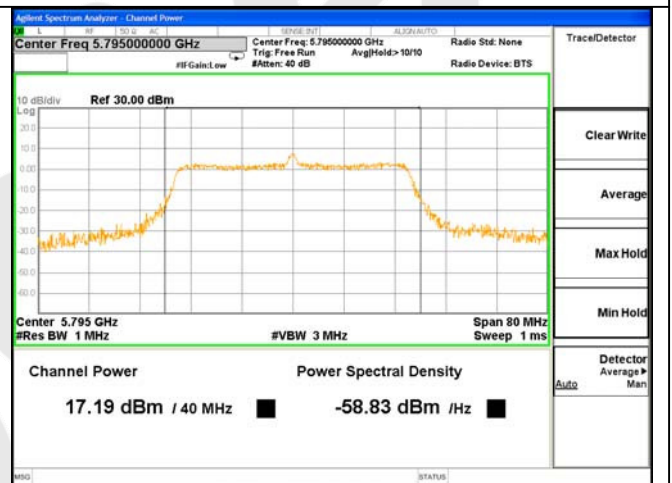

Test Mode: 802.11n(HT40)---5795

Test mode: IEEE 802.11AC(20)

Channel	Frequency (MHz)	Maximum transmit power (dBm)	Limit (dBm)	Result
Low	5180	12.68	24	Pass
Mid	5200	12.49	24	Pass
High	5240	12.53	24	Pass
Low	5745	12.80	30	Pass
Mid	5785	14.18	30	Pass
High	5825	15.03	30	Pass

Test mode: IEEE 802.11AC(40)

Channel	Frequency (MHz)	Maximum transmit power (dBm)	Limit (dBm)	Result
Low	5190	12.97	24	Pass
High	5230	12.12	24	Pass
Low	5755	18.41	30	Pass
High	5795	18.03	30	Pass

Test mode: IEEE 802.11AC(80)

Frequency (MHz)	Maximum transmit power (dBm)	Limit (dBm)	Result
5210	10.75	24	Pass
5775	17.95	30	Pass

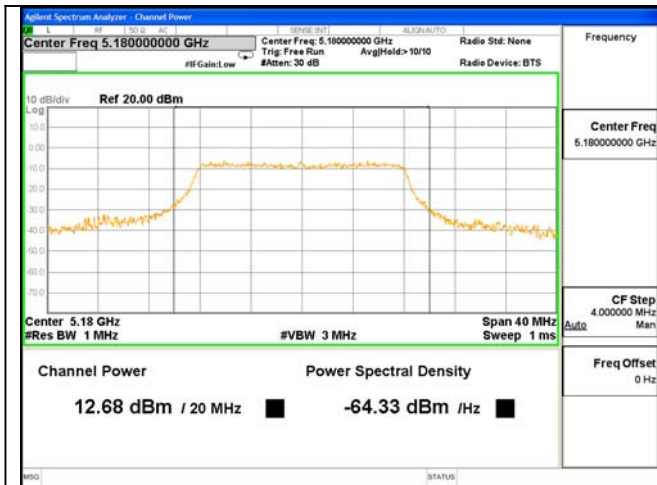

Test Mode: 802.11AC(20)---5180



Test Mode: 802.11AC(20)---5200

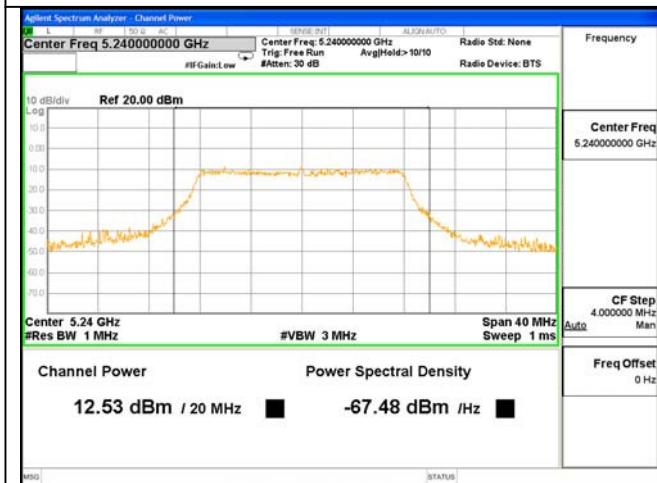

Test Mode: 802.11AC(20)---5240



Test Mode: 802.11AC(20)---5745

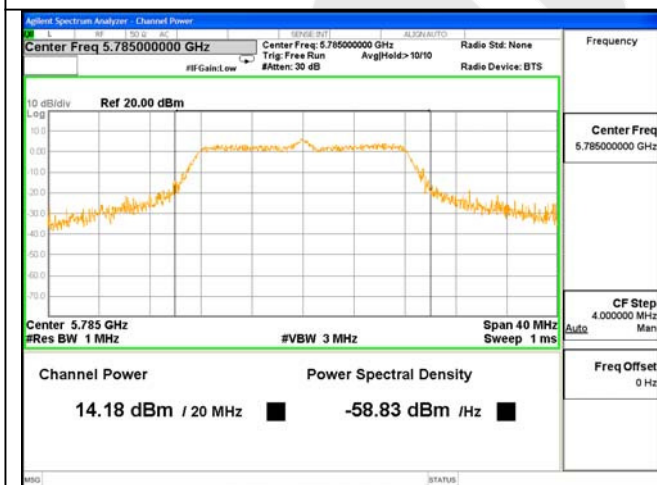

Test Mode: 802.11AC(20)---5785

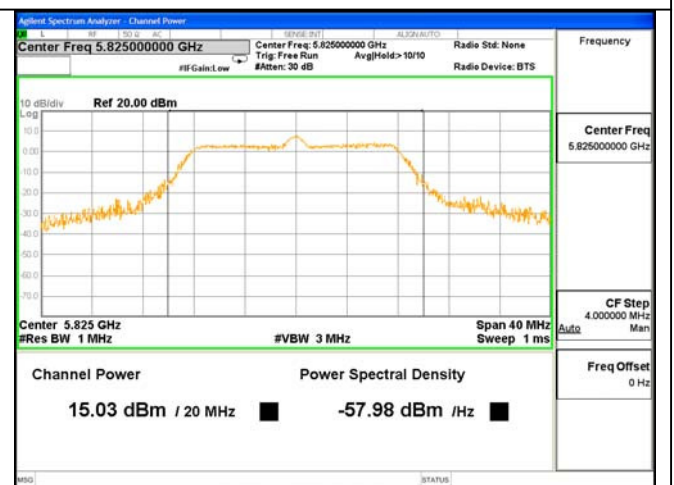

Test Mode: 802.11AC(20)---5825

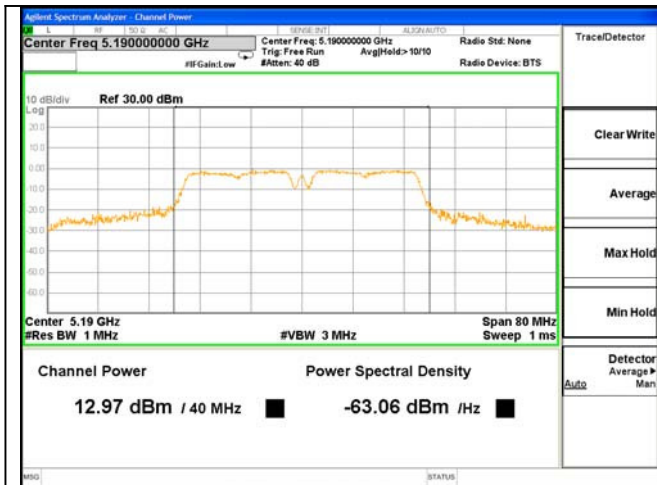

Test Mode: 802.11AC(40)---5190



Test Mode: 802.11AC(40)---5230



Test Mode: 802.11AC(40)---5755



Test Mode: 802.11AC(40)---5795



Test Mode: 802.11AC(80)---5210

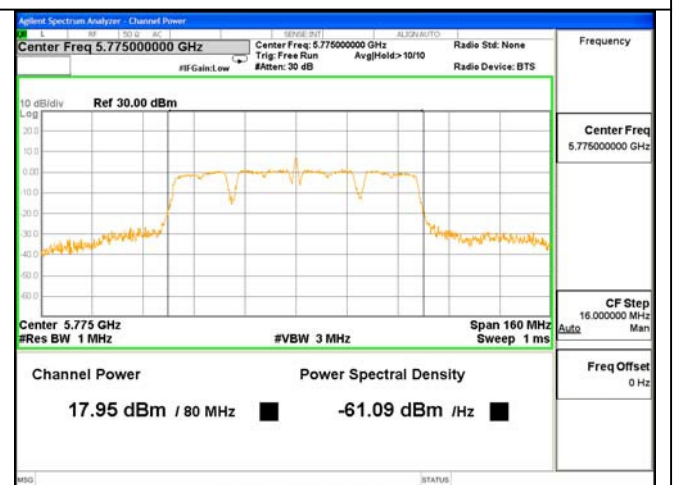

Test Mode: 802.11AC(80)---5755



## 6. Peak Power Spectral Density Test

### 6.1. Test Limit

1) For the band 5.15-5.25 GHz.

(i) For an outdoor access point operating in the band 5.15-5.25 GHz, the maximum conducted output power over the frequency band of operation shall not exceed 1 W provided the maximum antenna gain does not exceed 6 dBi. In addition, the maximum power spectral density shall not exceed 17 dBm in any 1 megahertz band. If transmitting antennas of directional gain greater than 6 dBi are used, both the maximum conducted output power and the maximum power spectral density shall be reduced by the amount in dB that the directional gain of the antenna exceeds 6 dBi. The maximum e.i.r.p. at any elevation angle above 30 degrees as measured from the horizon must not exceed 125 mW (21 dBm).

(ii) For an indoor access point operating in the band 5.15-5.25 GHz, the maximum conducted output power over the frequency band of operation shall not exceed 1 W provided the maximum antenna gain does not exceed 6 dBi. In addition, the maximum power spectral density shall not exceed 17 dBm in any 1 megahertz band. If transmitting antennas of directional gain greater than 6 dBi are used, both the maximum conducted output power and the maximum power spectral density shall be reduced by the amount in dB that the directional gain of the antenna exceeds 6 dBi.

(iii) For fixed point-to-point access points operating in the band 5.15-5.25 GHz, the maximum conducted output power over the frequency band of operation shall not exceed 1 W. In addition, the maximum power spectral density shall not exceed 17 dBm in any 1 megahertz band. Fixed point-to-point U-NII devices may employ antennas with directional gain up to 23 dBi without any corresponding reduction in the maximum conducted output power or maximum power spectral density. For fixed point-to-point transmitters that employ a directional antenna gain greater than 23 dBi, a 1 dB reduction in maximum conducted output power and maximum power spectral density is required for each 1 dB of antenna gain in excess of 23 dBi. Fixed, point-to-point operations exclude the use of point-to-multipoint systems, omnidirectional applications, and multiple collocated transmitters transmitting the same information. The operator of the U-NII device, or if the equipment is professionally installed, the installer, is responsible for ensuring that systems employing high gain directional antennas are used exclusively for fixed, point-to-point operations.

(iv) For mobile and portable client devices in the 5.15-5.25 GHz band, the maximum conducted output power over the frequency band of operation shall not exceed 250 mW provided the maximum antenna gain does not exceed 6 dBi. In addition, the maximum power spectral density shall not exceed 11 dBm in any 1 megahertz band. If transmitting antennas of directional gain greater than 6 dBi are used, both the maximum conducted output power and the maximum power spectral density shall be reduced by the amount in dB that the directional gain of the antenna exceeds 6 dBi.

(3) For the 5.25-5.35 GHz and 5.47-5.725 GHz bands, the maximum conducted output power over the frequency bands of operation shall not exceed the lesser of 250 mW or  $11 \text{ dBm} + 10 \log B$ , where B is the 26 dB emission bandwidth in megahertz. In addition, the maximum power spectral density shall not exceed 11 dBm in any 1 megahertz band. If transmitting antennas of directional

gain greater than 6 dBi are used, both the maximum conducted output power and the maximum power spectral density shall be reduced by the amount in dB that the directional gain of the antenna exceeds 6 dBi.

(3) For the band 5.725-5.85 GHz, the maximum conducted output power over the frequency band of operation shall not exceed 1 W. In addition, the maximum power spectral density shall not exceed 30 dBm in any 500-kHz band. If transmitting antennas of directional gain greater than 6 dBi are used, both the maximum conducted output power and the maximum power spectral density shall be reduced by the amount in dB that the directional gain of the antenna exceeds 6 dBi. However, fixed point-to-point U-NII devices operating in this band may employ transmitting antennas with directional gain greater than 6 dBi without any corresponding reduction in transmitter conducted power. Fixed, point-to-point operations exclude the use of point-to-multipoint systems, omnidirectional applications, and multiple collocated transmitters transmitting the same information. The operator of the U-NII device, or if the equipment is professionally installed, the installer, is responsible for ensuring that systems employing high gain directional antennas are used exclusively for fixed, point-to-point operations.

The maximum power spectral density is measured as a conducted emission by direct connection of a calibrated test instrument to the equipment under test. If the device cannot be connected directly, alternative techniques acceptable to the Commission may be used. Measurements in the 5.725-5.85 GHz band are made over a reference bandwidth of 500 kHz or the 26 dB emission bandwidth of the device, whichever is less. Measurements in the 5.15-5.25 GHz, 5.25-5.35 GHz, and the 5.47-5.725 GHz bands are made over a bandwidth of 1 MHz or the 26 dB emission bandwidth of the device, whichever is less. A narrower resolution bandwidth can be used, provided that the measured power is integrated over the full reference bandwidth.

## 6.2. Test Setup



## 6.3. Test Procedure

For devices operating in the bands 5.15-5.25 GHz, 5.25-5.35 GHz, and 5.47-5.725 GHz, the above procedures make use of 1 MHz RBW to satisfy directly the 1 MHz reference bandwidth specified in § 15.407(a)(5). For devices operating in the band 5.725-5.85 GHz, the rules specify a measurement bandwidth of 500 kHz. Many spectrum analyzers do not have 500 kHz RBW, thus a narrower RBW may need to be used. The rules permit the use of a RBWs less than 1 MHz, or 500 kHz, “provided that the measured power is integrated over the full reference bandwidth” to show the total power over the specified measurement bandwidth (i.e., 1 MHz, or 500 kHz).

1. The EUT is directly connected to the spectrum analyzer;
2. Set  $RBW \geq 1/T$ ;
3. Set  $VBW \geq 3 RBW$  .;
3. Set the span to encompass the entire emissions bandwidth (EBW) of the signal;
5. Detector=RMS;
6. Sweep time= auto couple;
7. Trace mode=max. hold;



#### 6.4. Test Equipment

Item	Equipment	Manufacturer	Model No.	Serial No.	Last Cal.	Cal. Interval
1.	Spectrum Analysis	Agilent	E4407B	US39390582	Apr. 16, 2016	1 Year
2.	Preamplifier	Instruments corporation	EMC011830	980100	Apr. 16, 2016	1 Year
3.	EMI Test Receiver	Rohde & Schwarz	ESPI	101604	Apr. 16, 2016	1 Year
4.	Double Ridged Horn Antenna	Instruments corporation	GTH-0118	351600	Apr. 19, 2016	1 Year
5.	Bilog Broadband Antenna	Schwarzbeck	VULB9163	VULB 9163-289	Apr. 19, 2016	1 Year
6.	Pre-amplifier	SONOMA	310N	186860	Apr. 16, 2016	1 Year
7.	EMI Test Software EZ-EMC	SHURPLE	N/A	N/A	N/A	N/A
8	Power Sensor	DAER	RPR3006W	15I00041SN046	Jun 30, 2016	1 Year
9	MXA Spectrum Analysis	Agilent	N9020A	MY51170037	Jun 30, 2016	1 Year
10	MXG RF Vector Signal Generator	Agilent	N5182A	MY48180656	Jun 30, 2016	1 Year
11	Signal Generator	Agilent	E4421B	MY41000743	Jun 30, 2016	1 Year
12	DC Power supply	IV	IV-8080	YQSB0096	Jun 30, 2016	1 Year
13	TEMP&HUMI PROGRAMMABLE CHAMBER	Bell Group	BE-THK-150M8	SE-0137	Mar. 16, 2016	1 Year

#### 6.5. Test Results

Pass.

Please refer to the following data.

Test mode: IEEE 802.11n(HT20)

Channel	Frequency (MHz)	Final Power Spectral Density (dBm)	Limit (dBm)	Result
Low	5180	0.081	11	Pass
Mid	5200	1.085	11	Pass
High	5240	-1.241	11	Pass
Low	5745	5.834	30	Pass
Mid	5785	7.527	30	Pass
High	5825	4.577	30	Pass

Test mode: IEEE 802.11n(HT40)

Channel	Frequency (MHz)	Final Power Spectral Density (dBm)	Limit (dBm)	Result
Low	5190	-1.463	11	Pass
High	5230	-3.382	11	Pass
Low	5755	4.489	30	Pass
High	5795	5.387	30	Pass

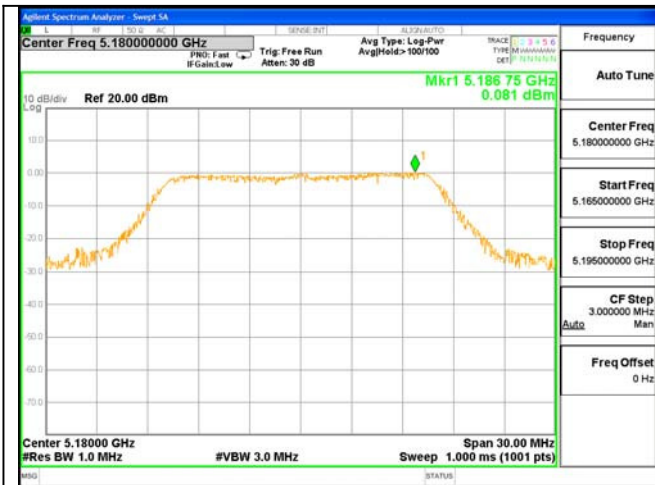

Test Mode: 802.11n(HT20)---5120

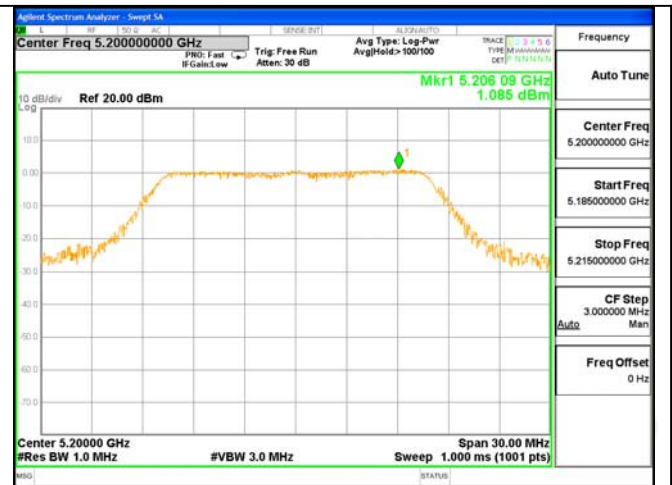

Test Mode: 802.11n(HT20)---5200



Test Mode: 802.11n(HT20)---5240



Test Mode: 802.11n(HT20)---5745

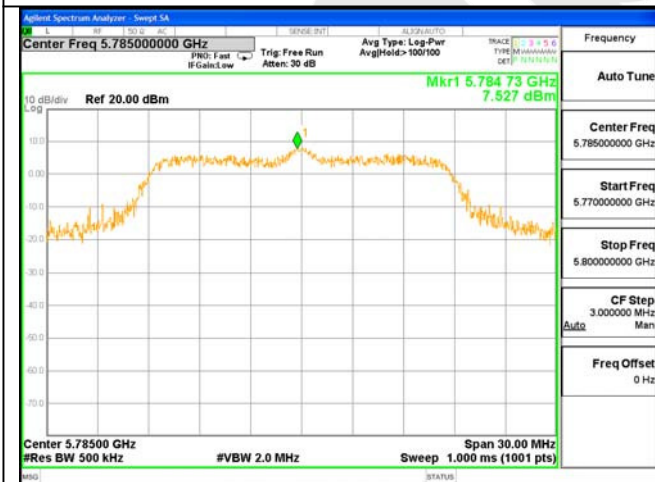

Test Mode: 802.11n(HT20)---5785



Test Mode: 802.11n(HT20)---5825

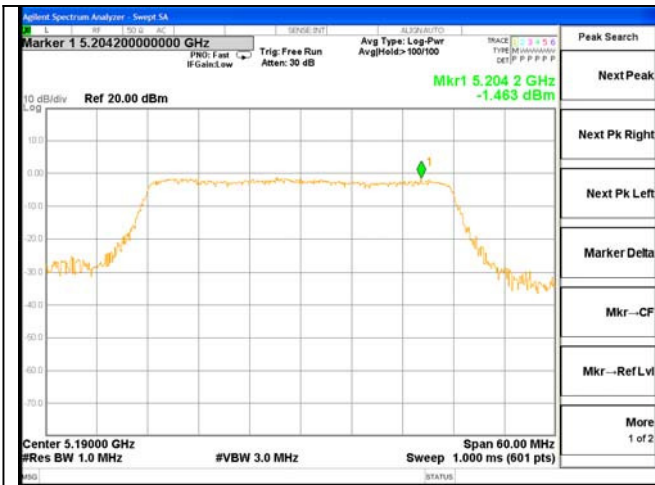

Test Mode: 802.11n(HT40)---5190

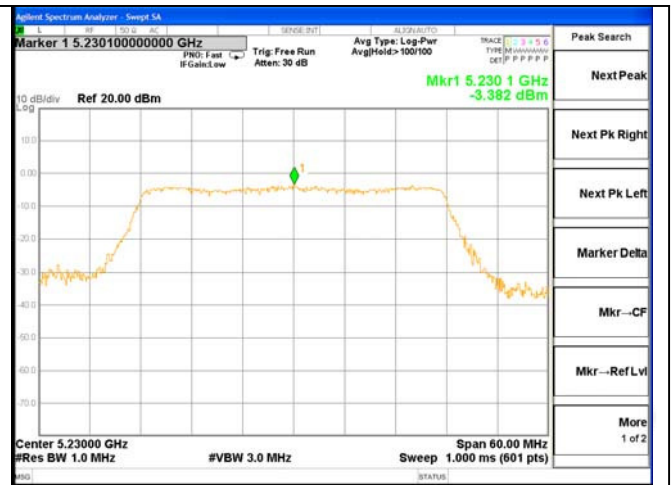

Test Mode: 802.11n(HT40)---5230



Test Mode: 802.11n(HT40)---5755

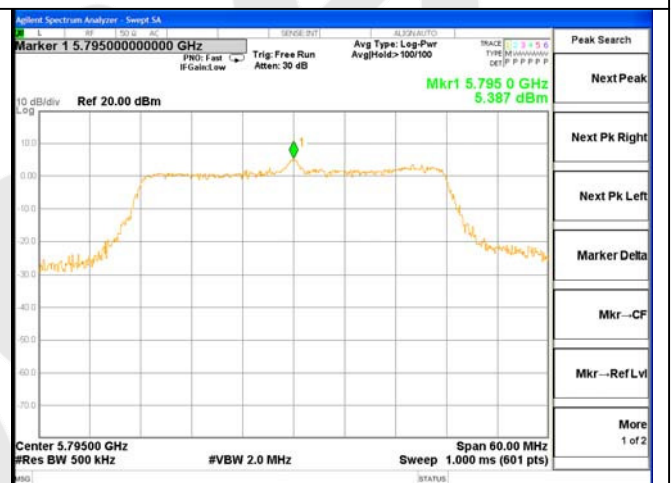

Test Mode: 802.11n(HT40)---5795

Test mode: IEEE 802.11AC(HT20)

Channel	Frequency (MHz)	Final Power Spectral Density (dBm)	Limit (dBm)	Result
Low	5180	-0.085	11	Pass
Mid	5200	-0.610	11	Pass
High	5240	-3.008	11	Pass
Low	5745	3.959	30	Pass
Mid	5785	5.261	30	Pass
High	5825	7.310	30	Pass

Test mode: IEEE 802.11AC(HT40)

Channel	Frequency (MHz)	Final Power Spectral Density (dBm)	Limit (dBm)	Result
Low	5190	-4.029	11	Pass
High	5230	-6.905	11	Pass
Low	5755	0.635	30	Pass
High	5795	2.656	30	Pass

Test mode: IEEE 802.11AC(HT80)

Frequency (MHz)	Final Power Spectral Density (dBm)	Limit (dBm)	Result
5210	-9.673	11	Pass
5755	5.303	30	Pass

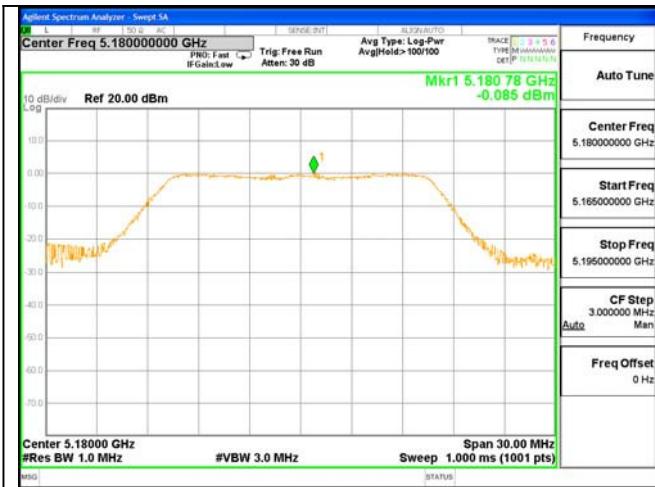

Test Mode: 802.11AC(20)---5120

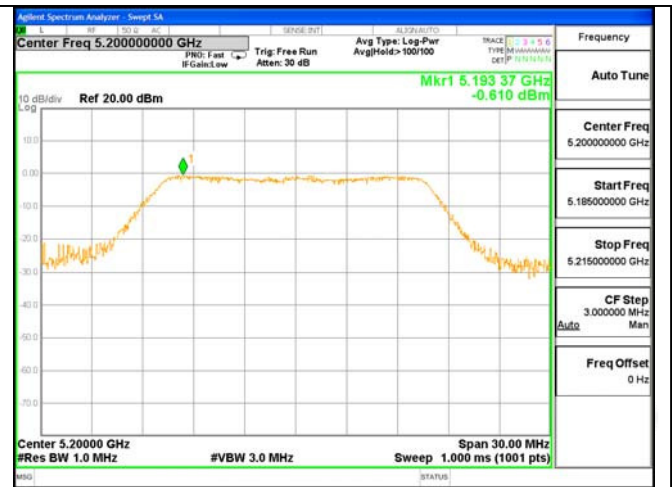

Test Mode: 802.11AC(20)---5200

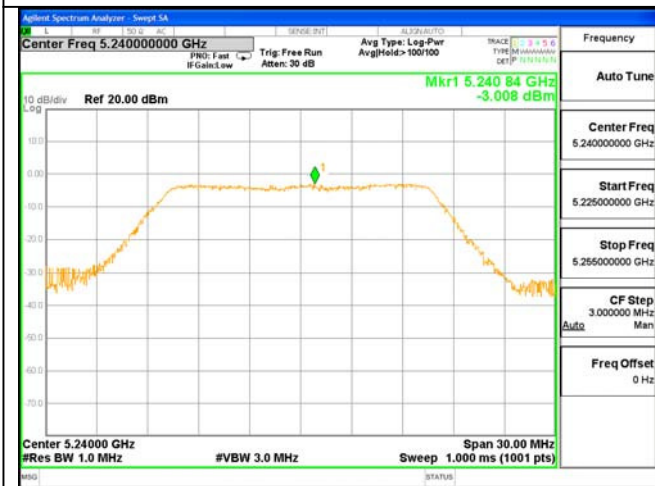

Test Mode: 802.11AC(20)---5240

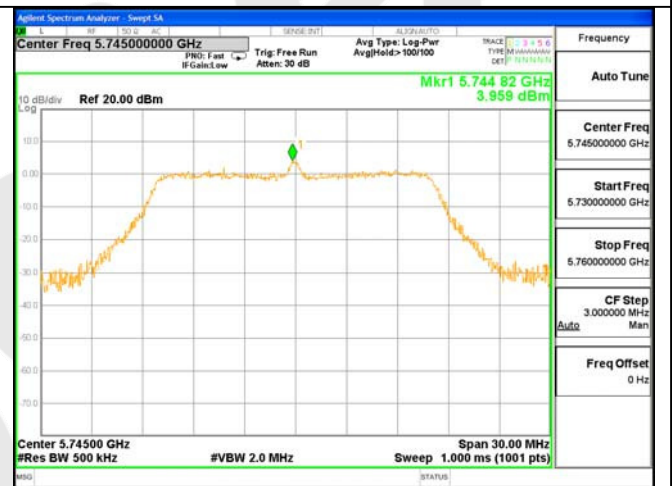

Test Mode: 802.11AC(20)---5745

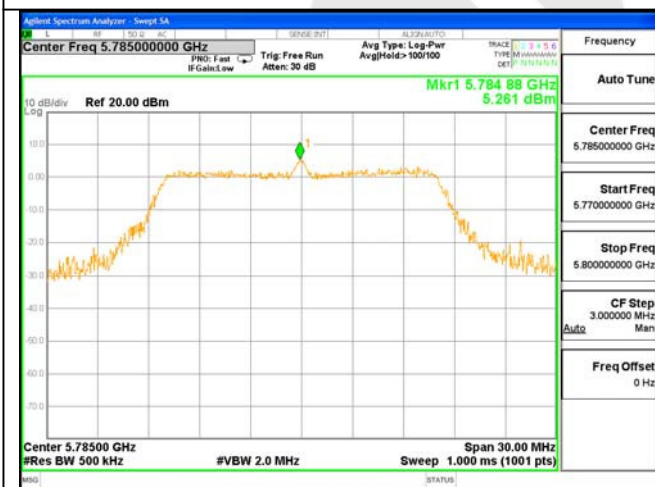

Test Mode: 802.11AC(20)---5785



Test Mode: 802.11AC(20)---5825



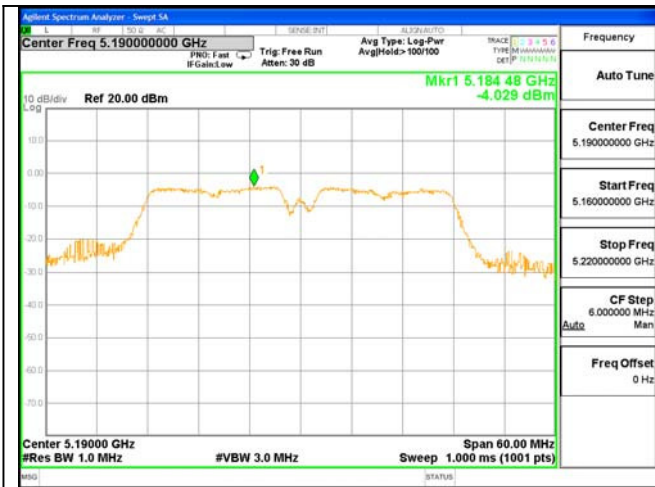

Test Mode: 802.11AC(40)---5190

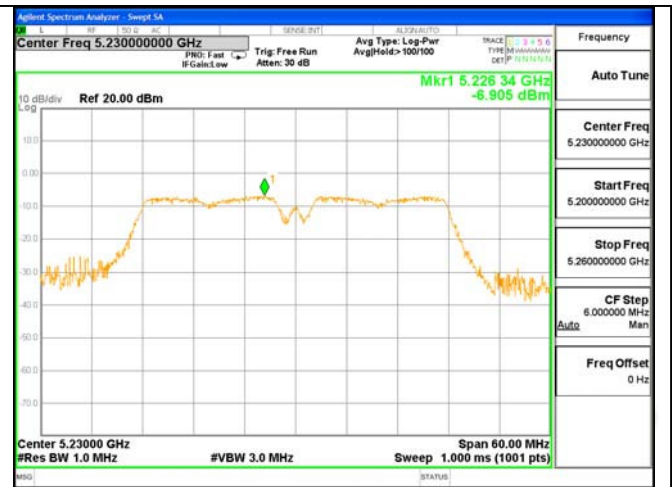

Test Mode: 802.11AC(40)---5230

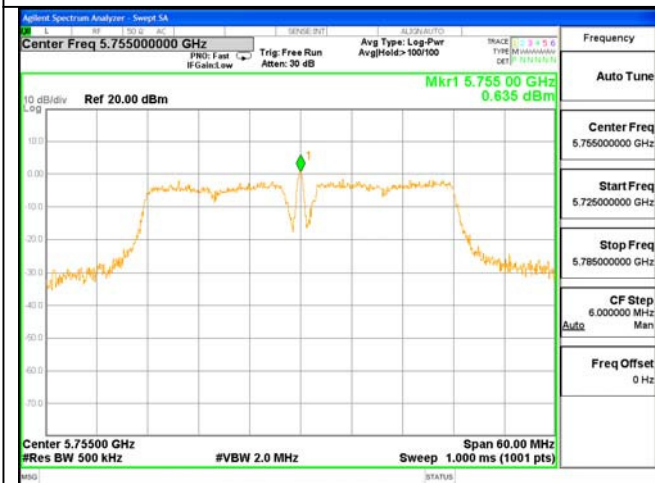

Test Mode: 802.11AC(40)---5755

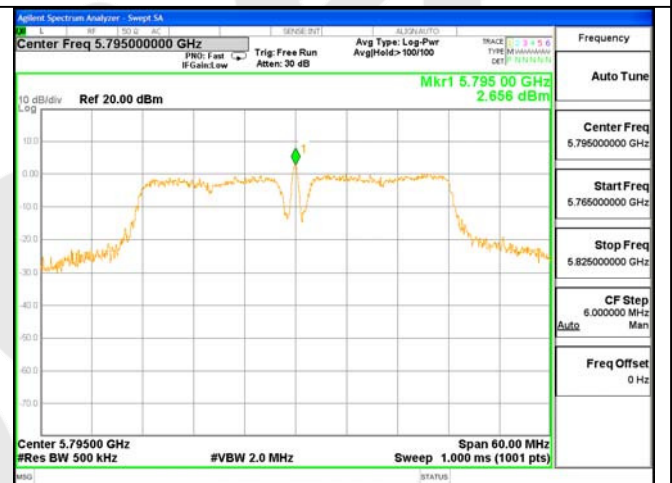

Test Mode: 802.11AC(40)---5795



Test Mode: 802.11AC(80)---5210



Test Mode: 802.11AC(80)---5775

## 7. Radiated Emission Test

### 7.1. Test Limit

#### 8.1.1. Test Limits (< 30 MHz)

Frequency (MHz)	Field Strength (microvolts/meter)	Measurement Distance (meter)
0.009-0.490	2400/F(kHz)	300
0.490-1.705	24000/F(kHz)	30
1.705-30.0	30	30

#### 7.1.2. Test Limits ( $\geq$ 30 MHz)

FIELD STRENGTH of Fundamental: @3M	FIELD STRENGTH of Harmonics	S15.209	
902-928 MHz		30 - 88 MHz	40 dBuV/m
2.4-2.4835 GHz		88 - 216 MHz	43.5
94 dB $\mu$ V/m @3m	54 dB $\mu$ V/m @3m	216 - 960 MHz	46
		ABOVE 960 MHz	54dBuV/m

#### 7.1.3. Restriction Band of Operation

MHz	MHz	MHz	GHz
0.090-0.110	16.42-16.423	399.9-410	4.5-5.15
10.495-0.505	16.69475-16.69525	608-614	5.35-5.46
2.1735-2.1905	16.80425-16.80475	960-1240	7.25-7.75
4.125-4.128	25.5-25.67	1300-1427	8.025-8.5
4.17725-4.17775	37.5-38.25	1435-1626.5	9.0-9.2
4.20725-4.20775	73-74.6	1645.5-1646.5	9.3-9.5
6.215-6.218	74.8-75.2	1660-1710	10.6-12.7
6.26775-6.26825	108-121.94	1718.8-1722.2	13.25-13.4
6.31175-6.31225	123-138	2200-2300	14.47-14.5
8.291-8.294	149.9-150.05	2310-2390	15.35-16.2
8.362-8.366	156.52475-156.52525	2483.5-2500	17.7-21.4
8.37625-8.38675	156.7-156.9	2690-2900	22.01-23.12
8.41425-8.41475	162.0125-167.17	3260-3267	23.6-24.0
12.29-12.293	167.72-173.2	3332-3339	31.2-31.8

All the emissions appearing within 15.205 restricted frequency bands shall not exceed the limits shown in 15.209, all the other emissions shall be at least 20dB below the fundamental emissions, or comply with 15.209 limits.

## 7.2. Test Setup

### 7.2.1. 9k to 30MHz emissions:

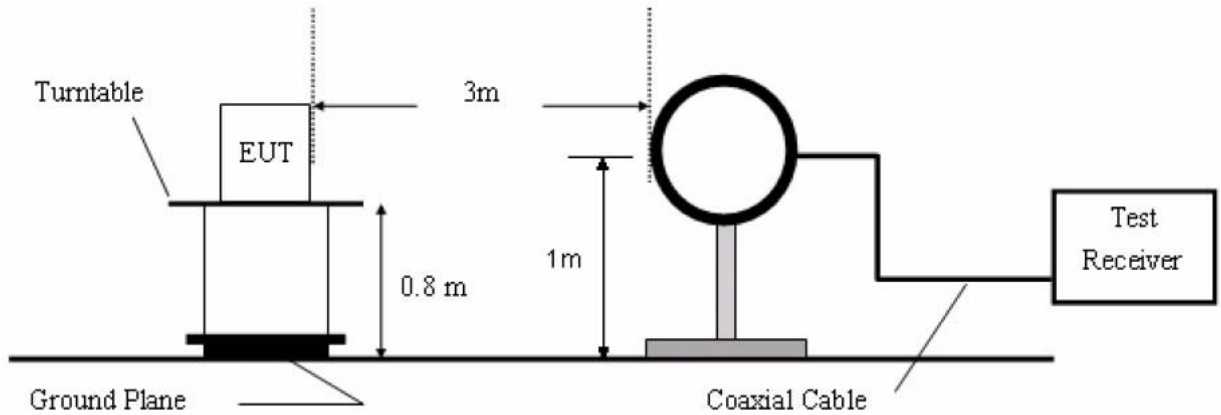

### 7.2.2. 30M to 1G emissions:

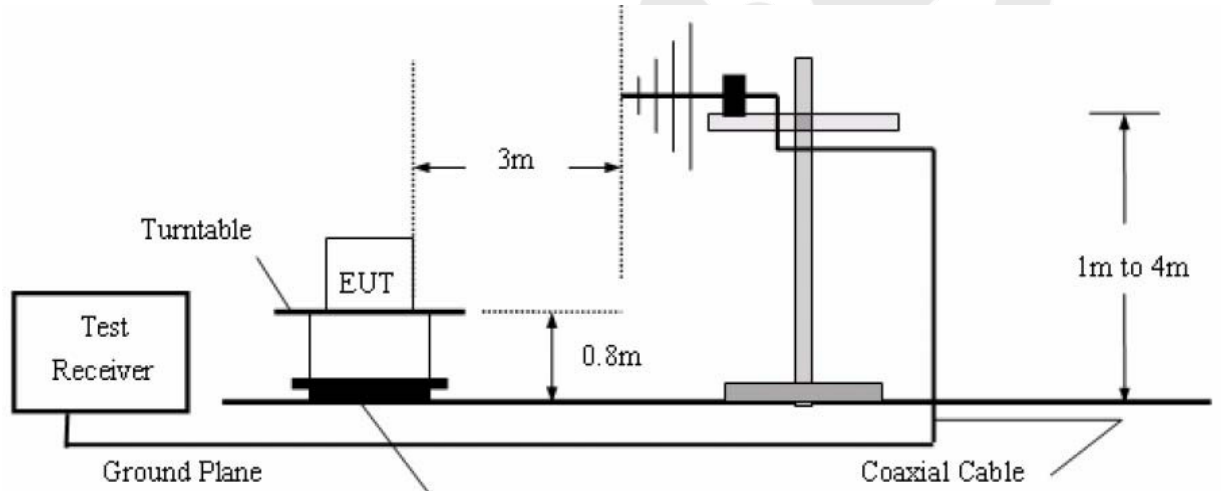

### 7.2.3. 1G to 40G emissions:

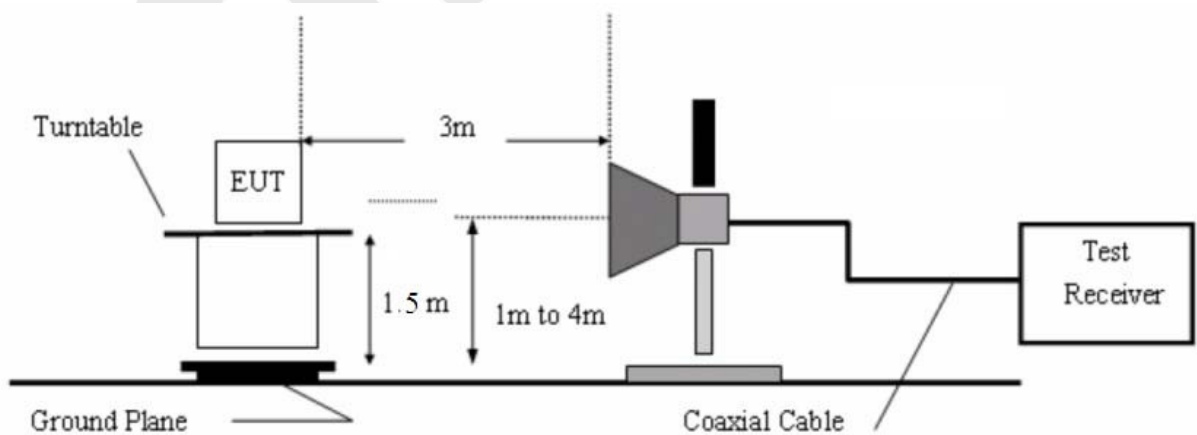

### 7.3. Test Procedure

For below 1GHz: The EUT is placed on a turntable, which is 0.8m above the ground plane.  
For above 1GHz: The EUT is placed on a turntable, which is 1.5m above the ground plane.

The turntable shall be rotated 360 degrees to determine the position of max. emission level.  
EUT is set 3m away from the receiving antenna, which is varied from 1m to 4m to find out the highest emission.

Measurements are made on 9KHz to 30MHz and 30MHz to 26GHz range with the transmitter set to the lowest, middle, and highest channels.

All readings from 30MHz to 1GHz are quasi-peak values with a resolution bandwidth of 120kHz. All reading are above 1GHz, peak & average values with a resolution bandwidth of 1MHz.

The EUT is tested in 9\*6\*6 Chamber. The device is evaluated in xyz orientation.

The test results are listed in Section 8.5.

### 7.4. Test Equipment

Item	Equipment	Manufacturer	Model No.	Serial No.	Last Cal.	Cal. Interval
1.	Spectrum Analysis	Agilent	E4407B	US39390582	Apr. 16, 2016	1 Year
2.	Preamplifier	Instruments corporation	EMC011830	980100	Apr. 16, 2016	1 Year
3.	EMI Test Receiver	Rohde & Schwarz	ESPI	101604	Apr. 16, 2016	1 Year
4.	Double Ridged Horn Antenna	Instruments corporation	GTH-0118	351600	Apr. 19, 2016	1 Year
5.	Bilog Broadband Antenna	Schwarzbeck	VULB9163	VULB 9163-289	Apr. 19, 2016	1 Year
6.	Pre-amplifier	SONOMA	310N	186860	Apr. 16, 2016	1 Year
7.	EMI Test Software EZ-EMC	SHURPLE	N/A	N/A	N/A	N/A
8	Power Sensor	DAER	RPR3006W	15I00041SN046	Jun 30, 2016	1 Year
9	MXA Spectrum Analysis	Agilent	N9020A	MY51170037	Jun 30, 2016	1 Year
10	MXG RF Vector Signal Generator	Agilent	N5182A	MY48180656	Jun 30, 2016	1 Year
11	Signal Generator	Agilent	E4421B	MY41000743	Jun 30, 2016	1 Year
12	DC Power supply	IV	IV-8080	YQSB0096	Jun 30, 2016	1 Year
13	TEMP&HUMI PROGRAMMABLE CHAMBER	Bell Group	BE-THK-150M8	SE-0137	Mar 16, 2016	1 Year
14	Spectrum Analysis	Rohde & Schwarz	FSV40	132.1.3008K39	Mar 17, 2016	1 Year

				-100965		
15	Pre-amplifier	Agilent	8449B	3008A00252	Mar 17, 2016	1 Year
16	Horn Antenna	SCHWARZBECK	BBHA917 0	9170-068	Mar 17, 2016	1 Year

### 7.5. Test Results

The EUT was tested on (Playing video+HDMI output+Internet connect mode, Playing video+VGA output+Internet connect+WiFi operating mode) modes, only the worst data of (Playing video+HDMI output+Internet connect mode) is attached in the following pages. Only the worst case (x orientation).

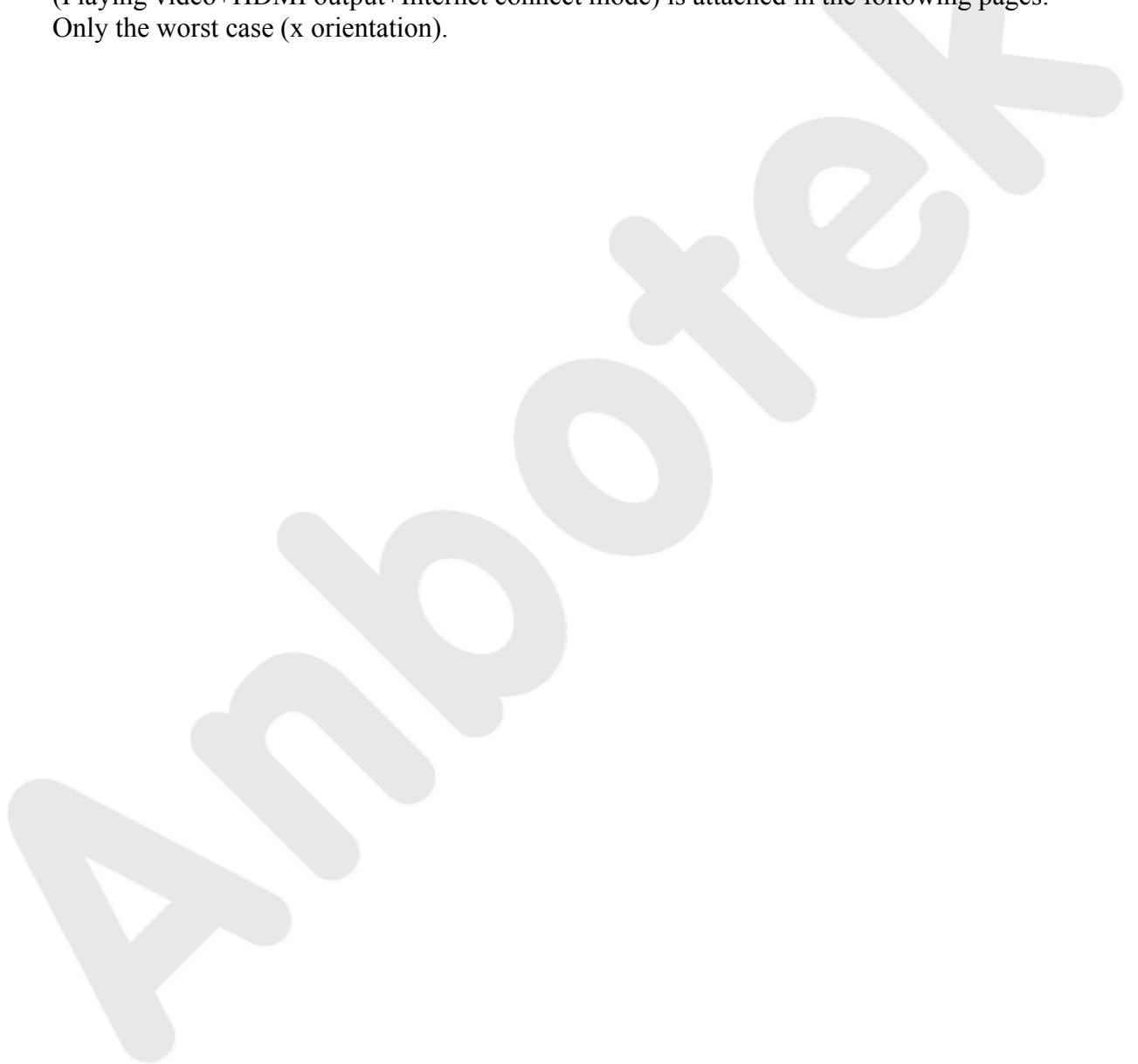

Job No.:	0116061074I	Plarization:	Horizontal
Standard:	(RE)FCC PART15 C_3m	Power Source:	AC 120V, 60Hz for adapter
Test item:	Radiation Test	Temp.(C)/Hum. (%RH):	24.3(C)/55 % RH
Test Mode:	Playing video+HDMI output+Internet connect mode	Distance:	3m

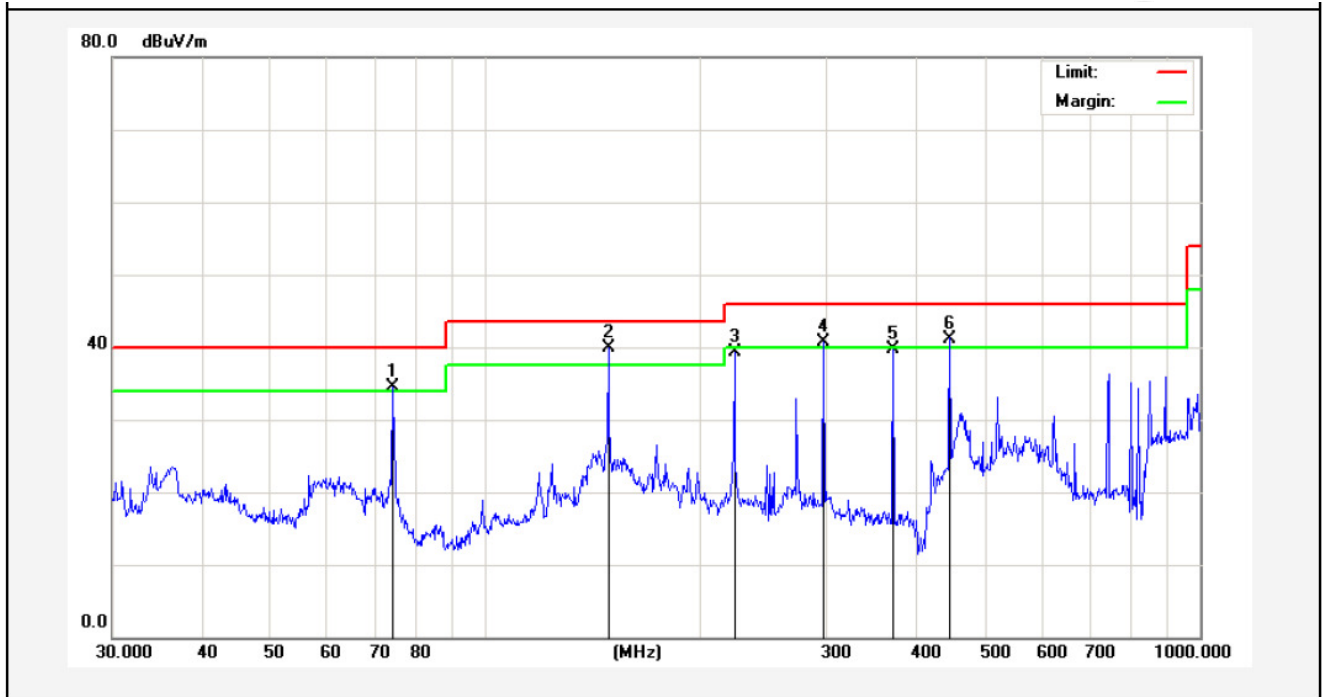

No.	Freq. (MHz)	Reading (dBuV/m)	Factor (dB/m)	Result (dBuV/m)	Limit (dBuV/)	Over Limit (dB)	Detector	Height (cm)	degree (deg)	Remark
1	74.1350	54.84	-20.42	34.42	40.00	-5.58	QP	300	360	
2	148.4410	63.17	-23.36	39.81	43.50	-3.69	QP	300	0	
3	222.9501	59.08	-19.82	39.26	46.00	-6.74	peak			
4	297.2241	58.56	-17.76	40.80	46.00	-5.20	QP	300	360	
5	372.0045	53.21	-13.43	39.78	46.00	-6.22	peak			
6	446.4141	53.37	-12.17	41.20	46.00	-4.80	QP	300	0	



Job No.:	0116061074I	Plarization:	Vertical
Standard:	(RE)FCC PART15 C _3m	Power Source:	AC 120V, 60Hz for adapter
Test item:	Radiation Test	Temp.(C)/Hum.(%RH):	24.3(C)/55%RH
Test Mode:	Playing video+HDMI output+Internet connect mode	Distance:	3m

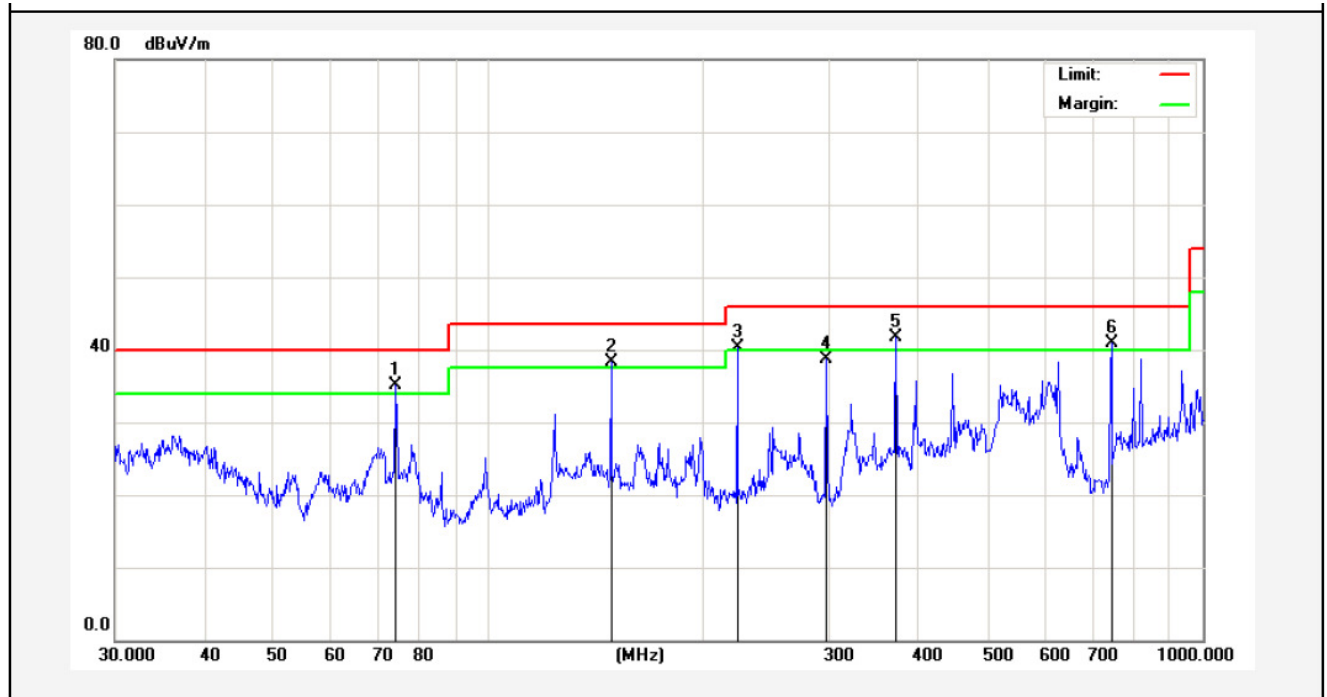

No.	Freq. (MHz)	Reading (dBuV/m)	Factor (dB/m)	Result (dBuV/m)	Limit (dBuV/)	Over Limit (dB)	Detector	Height (cm)	degree (deg)	Remark
1	74.1350	55.52	-20.42	35.10	40.00	-4.90	QP	100	360	
2	148.4410	56.74	-18.36	38.38	43.50	-5.12	QP	100	360	
3	222.9500	55.24	-14.97	40.27	46.00	-5.73	QP	100	0	
4	297.2241	53.37	-14.76	38.61	46.00	-7.39	peak			
5	372.0045	54.20	-12.43	41.77	46.00	-4.23	QP	100	0	
6	744.8659	48.13	-7.15	40.98	46.00	-5.02	QP	100	0	

The EUT was tested on (IEEE 802.11n(HT20) ;IEEE 802.11n(HT40);IEEE 802.11ac(HT20);IEEE 802.11ac(HT40);802.11ac(HT80))modes, only the worst data of (IEEE 802.11n(HT20)) is attached in the following pages.

**Test mode: IEEE 802.11n(HT20)**

**Low Channel(5180MHz)**

Frequency	Antenna	Reading	Cable Loss	Ant Factor	Amplifier	Corrected Level	Limits	Det
(MHz)	Polarization	(dBuV/m)	(dB)	(dB)	(dB)	(dBuV/m)	(dBuV/m)	Mode
10360	H	46.87	3.55	38.2	32.1	56.52	74	PK
10360	H	40.53	3.55	38.2	32.1	50.18	54	AV
10360	V	48.12	3.55	38.2	32.1	57.77	74	PK
10360	V	40.28	3.55	38.2	32.1	49.93	54	AV
15540	H	48.64	5.81	39.8	31.75	62.50	74	PK
15540	H	36.97	5.81	39.8	31.75	50.83	54	AV
15540	V	44.67	5.81	39.8	31.75	58.53	74	PK
15540	V	36.37	5.81	39.8	31.75	50.23	54	AV
20720	H	--	7.85	40.2	40.4	--	74	PK
20720	H	--	7.85	40.2	40.4	--	54	AV
20720	V	--	7.85	40.2	40.4	--	74	PK
20720	V	--	7.85	40.2	40.4	--	54	AV

**Middle Channel(5200MHz)**

Frequency	Antenna	Reading	Cable Loss	Ant Factor	Amplifier	Corrected Level	Limits	Det
(MHz)	Polarization	(dBuV/m)	(dB)	(dB)	(dB)	(dBuV/m)	(dBuV/m)	Mode
10400	H	47.15	3.61	38.2	32.1	56.86	74	PK
10400	H	40.42	3.61	38.2	32.1	50.13	54	AV
10400	V	48.08	3.61	38.2	32.1	57.79	74	PK
10400	V	40.07	3.61	38.2	32.1	49.78	54	AV
15600	H	47.72	5.83	39.8	31.75	61.60	74	PK
15600	H	36.13	5.83	39.8	31.75	50.01	54	AV
15600	V	44.66	5.83	39.8	31.75	58.54	74	PK
15600	V	36.91	5.83	39.8	31.75	50.79	54	AV
20800	H	--	7.92	40.2	40.4	--	74	PK
20800	H	--	7.92	40.2	40.4	--	54	AV
20800	V	--	7.92	40.2	40.4	--	74	PK
20800	V	--	7.92	40.2	40.4	--	54	AV

**High Channel(5240MHz)**

Frequency	Antenna	Reading	Cable Loss	Ant Factor	Amplifier	Corrected Level	Limits	Det
(MHz)	Polarization	(dBuV/m)	(dB)	(dB)	(dB)	(dBuV/m)	(dBuV/m)	Mode
10480	H	46.84	3.62	38.2	32.1	56.56	74	PK
10480	H	39.56	3.62	38.2	32.1	49.28	54	AV
10480	V	48.70	3.62	38.2	32.1	58.42	74	PK
10480	V	39.22	3.62	38.2	32.1	48.94	54	AV
15720	H	47.28	5.86	39.8	31.75	61.19	74	PK
15720	H	36.58	5.86	39.8	31.75	50.49	54	AV
15720	V	44.11	5.86	39.8	31.75	58.02	74	PK
15720	V	36.79	5.86	39.8	31.75	50.70	54	AV
20960	H	--	7.95	40.2	40.4	--	74	PK
20960	H	--	7.95	40.2	40.4	--	54	AV
20960	V	--	7.95	40.2	40.4	--	74	PK
20960	V	--	7.95	40.2	40.4	--	54	AV

Note: 1. Level = Reading + AF + Cable - Preamp + Filter - Dist, Margin = Level - Limit

Note: 2. Remark “---” means that the emissions level is too low to be measured

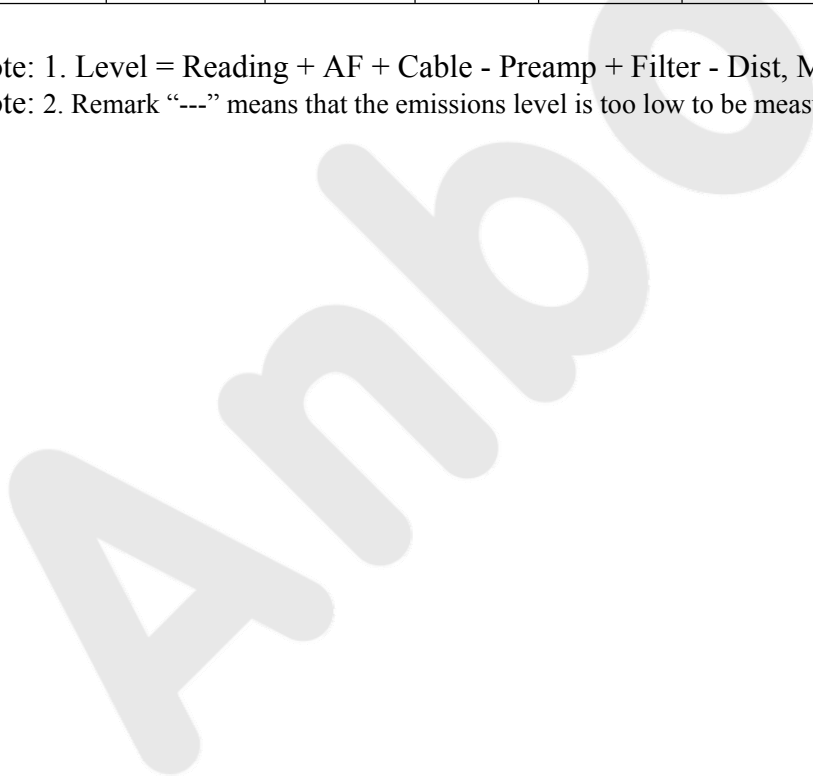

**Low Channel(5745MHz)**

Frequency	Antenna	Reading	Cable Loss	Ant Factor	Amplifier	Corrected Level	Limits	Det
(MHz)	Polarization	(dBuV/m)	(dB)	(dB)	(dB)	(dBuV/m)	(dBuV/m)	Mode
11490	H	46.95	3.63	38.2	32.1	56.68	74	PK
11490	H	40.18	3.63	38.2	32.1	49.91	54	AV
11490	V	48.44	3.63	38.2	32.1	58.17	74	PK
11490	V	40.07	3.63	38.2	32.1	49.80	54	AV
17235	H	48.57	5.85	39.8	31.75	62.47	74	PK
17235	H	36.81	5.85	39.8	31.75	50.71	54	AV
17235	V	45.25	5.85	39.8	31.75	59.15	74	PK
17235	V	36.91	5.85	39.8	31.75	50.81	54	AV
22980	H	--	7.97	40.2	40.4	--	74	PK
22980	H	--	7.97	40.2	40.4	--	54	AV
22980	V	--	7.97	40.2	40.4	--	74	PK
22980	V	--	7.97	40.2	40.4	--	54	AV

**Middle Channel(5785MHz)**

Frequency	Antenna	Reading	Cable Loss	Ant Factor	Amplifier	Corrected Level	Limits	Det
(MHz)	Polarization	(dBuV/m)	(dB)	(dB)	(dB)	(dBuV/m)	(dBuV/m)	Mode
11570	H	47.55	3.66	38.2	32.1	57.31	74	PK
11570	H	40.41	3.66	38.2	32.1	50.17	54	AV
11570	V	47.51	3.66	38.2	32.1	57.27	74	PK
11570	V	39.11	3.66	38.2	32.1	48.87	54	AV
17355	H	47.12	5.88	39.8	31.75	61.05	74	PK
17355	H	37.21	5.88	39.8	31.75	51.14	54	AV
17355	V	45.20	5.88	39.8	31.75	59.13	74	PK
17355	V	37.55	5.88	39.8	31.75	51.48	54	AV
23140	H	--	7.95	40.2	40.4	--	74	PK
23140	H	--	7.95	40.2	40.4	--	54	AV
23140	V	--	7.95	40.2	40.4	--	74	PK
23140	V	--	7.95	40.2	40.4	--	54	AV

**High Channel(5825MHz)**

Frequency	Antenna	Reading	Cable Loss	Ant Factor	Amplifier	Corrected Level	Limits	Det
(MHz)	Polarization	(dBuV/m)	(dB)	(dB)	(dB)	(dBuV/m)	(dBuV/m)	Mode
11650	H	46.75	3.68	38.2	32.1	56.53	74	PK
11650	H	40.63	3.68	38.2	32.1	50.41	54	AV
11650	V	48.01	3.68	38.2	32.1	57.79	74	PK
11650	V	40.55	3.68	38.2	32.1	50.33	54	AV
17475	H	48.38	5.89	39.8	31.75	62.32	74	PK
17475	H	36.78	5.89	39.8	31.75	50.72	54	AV
17475	V	45.78	5.89	39.8	31.75	59.72	74	PK
17475	V	37.08	5.89	39.8	31.75	51.02	54	AV
23300	H	--	7.98	40.2	40.4	--	74	PK
23300	H	--	7.98	40.2	40.4	--	54	AV
23300	V	--	7.98	40.2	40.4	--	74	PK
23300	V	--	7.98	40.2	40.4	--	54	AV

Note: 1. Level = Reading + AF + Cable - Preamp + Filter - Dist, Margin = Level - Limit  
 Note: 2. Remark “---” means that the emissions level is too low to be measured

## 8. Band Edge Test

### 8.1. Test Limit

For transmitter operating in the 5.15-5.25GHz band: all emissions outside of the 5.15-5.35GHz outside of the 5.15-5.35GHz band shall not exceed an EIRP of -27dBm/MHz.

For transmitters operating in the 5.25-5.35GHz band: all emissions outside of the 5.15-5.35GHz band shall not exceed an EIRP of -27dBm/MHz. Devices operating in the 5.25-5.35GHz band that generate emissions in the 5.15-5.25GHz band must meet all applicable technical requirements for operation in the 5.15-5.25GHz band (including indoor use) or alternatively meet an out-of-band emission EIRP limit of -27dBm/MHz in the 5.15-5.25GHz band.

For transmitters operating in the 5.45-5.725GHz band: all emissions outside of the 5.47-5.725GHz band shall not exceed an EIRP of -27dBm/MHz.

For transmitters operating in the 5.725-5.825GHz band: all emissions within the frequency range from the band edge to 10MHz above or below the band edge shall not exceed an EIRP of -17dBm/MHz; for frequencies 10MHz or greater above or below the band edge, emissions shall not exceed an EIRP of -27dBm/MHz.

### 8.2. Test Setup

Same as clause 7.2.

### 8.3. Test Procedure

For below 1GHz: The EUT is placed on a turntable, which is 0.8m above the ground plane.  
For above 1GHz: The EUT is placed on a turntable, which is 1.5m above the ground plane.

The turntable shall be rotated 360 degrees to determine the position of max. emission level. EUT is set 3m away from the receiving antenna, which is varied from 1m to 4m to find out the highest emission.

Measurements are made on 9KHz to 30MHz and 30MHz to 26GHz range with the transmitter set to the lowest, middle, and highest channels.

All readings from 30MHz to 1GHz are quasi-peak values with a resolution bandwidth of 120kHz. All reading are above 1GHz, peak & average values with a resolution bandwidth of 1MHz.

The EUT is tested in 9\*6\*6 Chamber.

The test results are listed in Section 9.5.



### 8.4. Test Equipment

Item	Equipment	Manufacturer	Model No.	Serial No.	Last Cal.	Cal. Interval
1.	Spectrum Analysis	Agilent	E4407B	US39390582	Apr. 16, 2016	1 Year
2.	Preamplifier	Instruments corporation	EMC011830	980100	Apr. 16, 2016	1 Year
3.	EMI Test Receiver	Rohde & Schwarz	ESPI	101604	Apr. 16, 2016	1 Year
4.	Double Ridged Horn Antenna	Instruments corporation	GTH-0118	351600	Apr. 19, 2016	1 Year
5.	Bilog Broadband Antenna	Schwarzbeck	VULB9163	VULB 9163-289	Apr. 19, 2016	1 Year
6.	Pre-amplifier	SONOMA	310N	186860	Apr. 16, 2016	1 Year
7.	EMI Test Software EZ-EMC	SHURPLE	N/A	N/A	N/A	N/A
8	Power Sensor	DAER	RPR3006W	15I00041SN046	Jun 30, 2016	1 Year
9	MXA Spectrum Analysis	Agilent	N9020A	MY51170037	Jun 30, 2016	1 Year
10	MXG RF Vector Signal Generator	Agilent	N5182A	MY48180656	Jun 30, 2016	1 Year
11	Signal Generator	Agilent	E4421B	MY41000743	Jun 30, 2016	1 Year
12	DC Power supply	IV	IV-8080	YQSB0096	Jun 30, 2016	1 Year
13	TEMP&HUMI PROGRAMMABLE CHAMBER	Bell Group	BE-THK-150M8	SE-0137	Mar 16, 2016	1 Year
14	Spectrum Analysis	Rohde & Schwarz	FSV40	132.1.3008K39-100965	Mar 17, 2016	1 Year
15	Pre-amplifier	Agilent	8449B	3008A00252	Mar 17, 2016	1 Year
16	Horn Antenna	SCHWARZBECK	BBHA9170	9170-068	Mar 17, 2016	1 Year

### 8.5. Test Results

Please refer to the following pages.

The EUT was tested on (IEEE 802.11n(HT20) ;IEEE 802.11n(HT40);IEEE 802.11ac(HT20);IEEE 802.11ac(HT40);802.11ac(HT80))modes, only the worst data of (IEEE 802.11n(HT20)) is attached in the following pages.

Job No.:	0116061074I	Plarization:	Horizontal-PEAK
Standard:	(RE)FCC PART15 E_3m	Power Source:	AC 120V, 60Hz for adapter
Test item:	Radiation Test	Temp.(C)/Hum. (%RH):	24.3(C)/55 % RH
Test Mode:	IEEE 802.11n(HT20) (5180MHz)	Distance:	3m

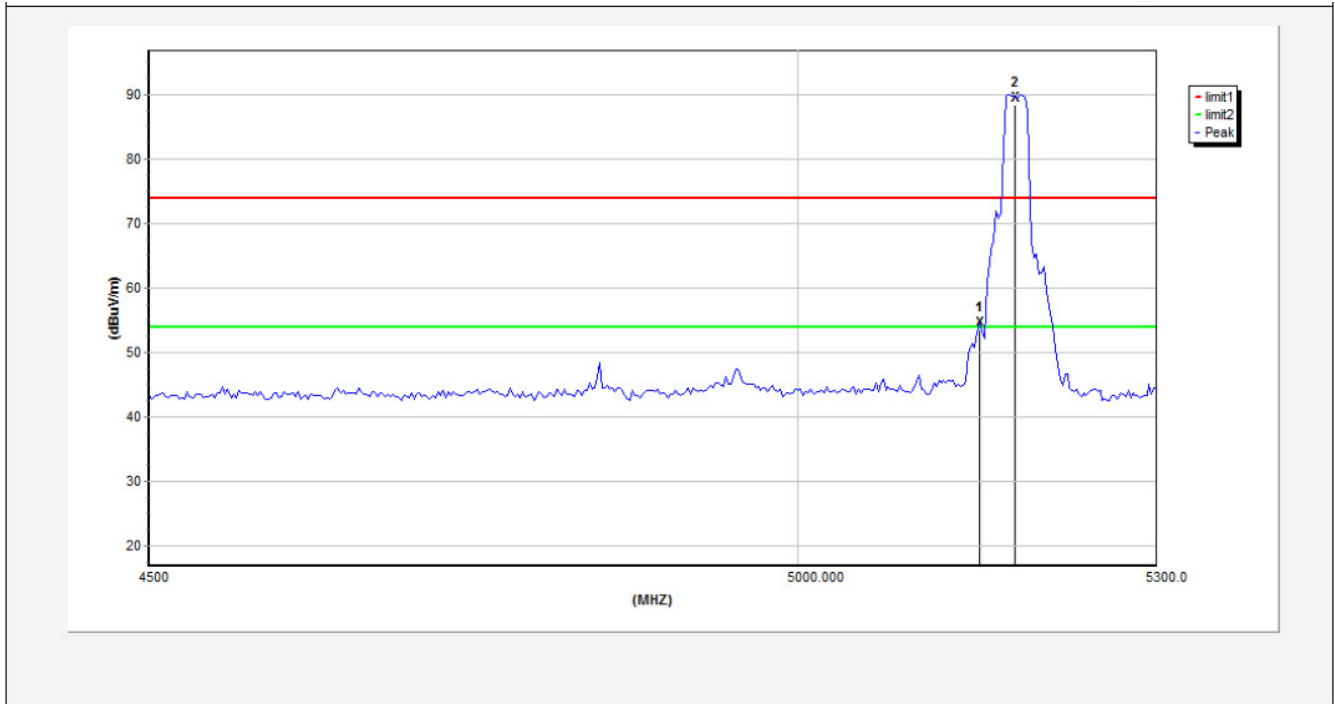

Frequency	CableLoss	AntFactor	PreampFactor	ReadLevel	Level	Limit	Over Limit	Remark
MHz	dB	dB/m	dB	dBμV	dBμV/m	dBμV/m	dB	
5150.000	3.85	37.51	32.60	44.84	53.60	74.00	-20.40	Peak

**Remark:**

According to KDB 789033 section g (2), for measurement above 1000MHz @3m distance, out-of-band emission that complies with both the peak and average limits of § 15.209 is not required to satisfy the -27 dBm/MHz or -17 dBm/MHz maximum emission limit.

Job No.:	0116061074I	Plarization:	Vertical-PEAK
Standard:	(RE)FCC PART15 E_3m	Power Source:	AC 120V, 60Hz for adapter
Test item:	Radiation Test	Temp.(C)/Hum.(%RH):	24.3(C)/55% RH
Test Mode:	IEEE 802.11n(HT20) (5180MHz)	Distance:	3m

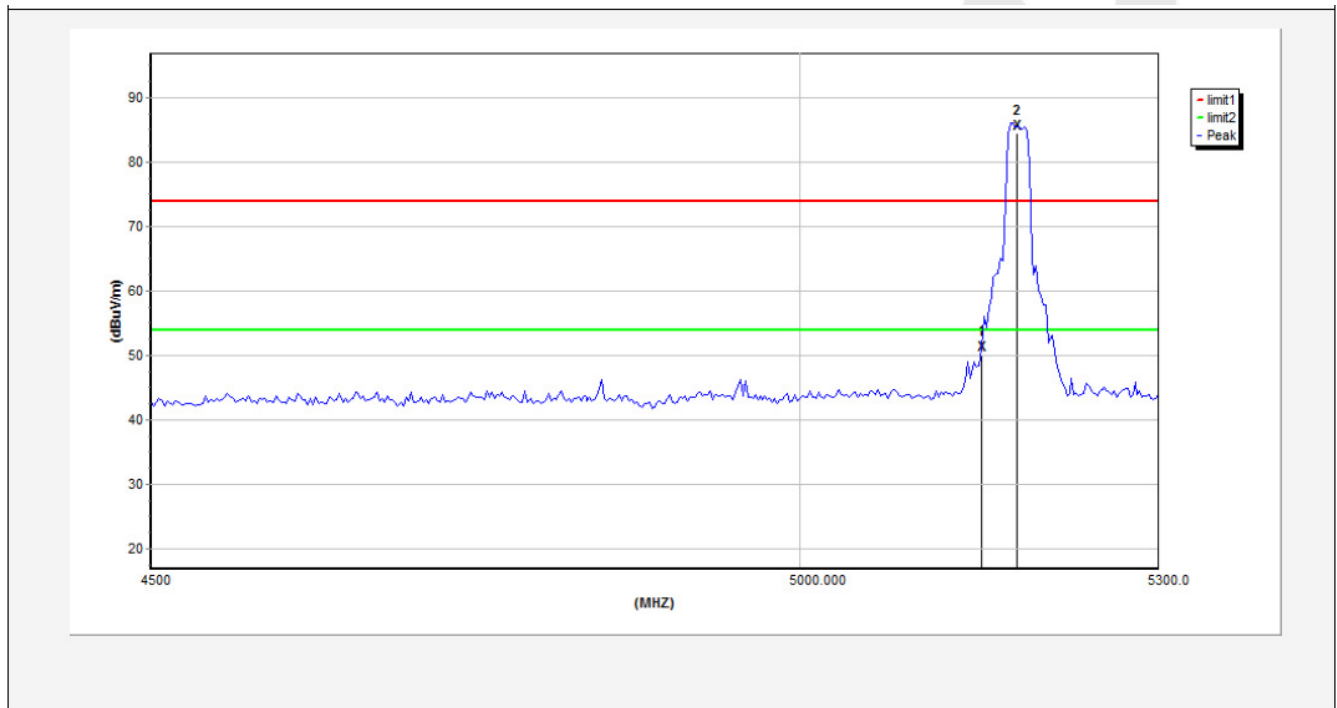

Frequency	CableLoss	AntFactor	PreampFactor	ReadLevel	Level	Limit	Over Limit	Remark
MHz	dB	dB/m	dB	dBμV	dBμV/m	dBμV/m	dB	
5150.000	3.85	37.51	32.60	43.79	52.55	74.00	-21.45	Peak

**Remark:**

According to KDB 789033 section g (2), for measurement above 1000MHz @3m distance, out-of-band emission that complies with both the peak and average limits of § 15.209 is not required to satisfy the -27 dBm/MHz or -17 dBm/MHz maximum emission limit.

Job No.:	0116061074I	Plarization:	Horizontal-AV
Standard:	(RE)FCC PART15 E_3m	Power Source:	AC 120V, 60Hz for adapter
Test item:	Radiation Test	Temp.(C)/Hum.(%RH):	24.3(C)/55%RH
Test Mode:	IEEE 802.11n(HT20) (5180MHz)	Distance:	3m

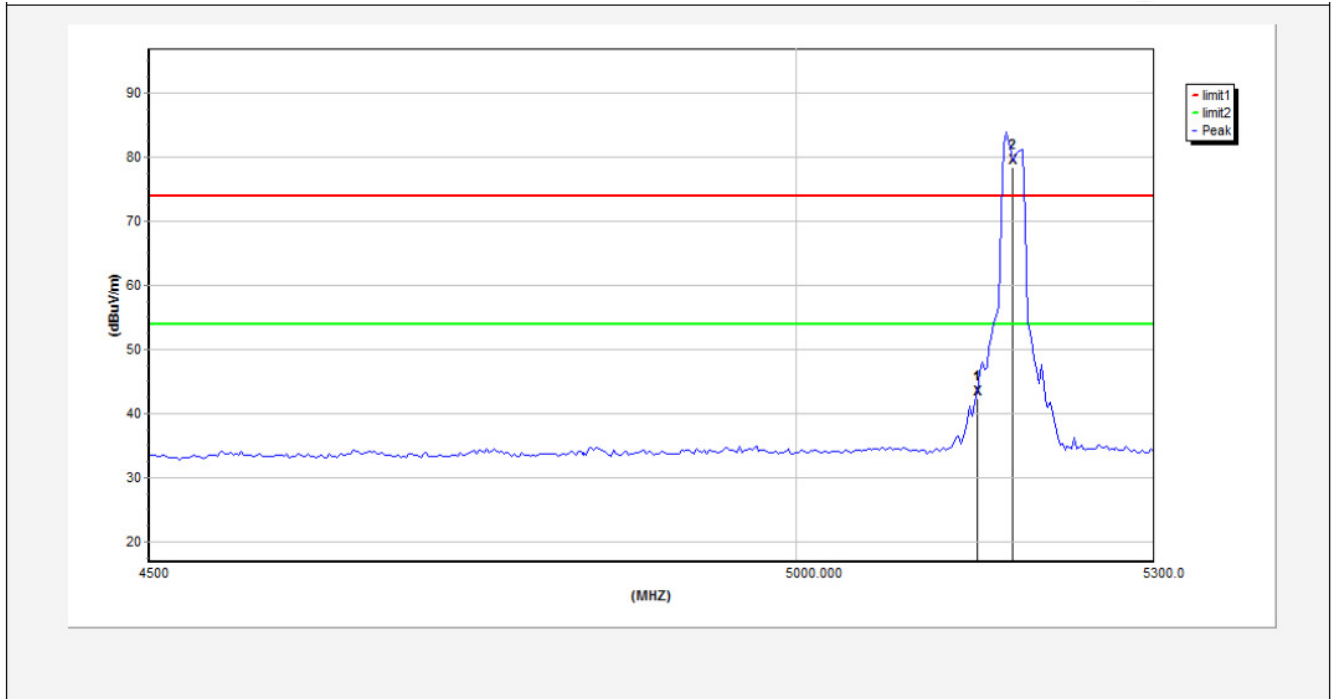

Frequency	CableLoss	AntFactor	PreampFactor	ReadLevel	Level	Limit	Over Limit	Remark
MHz	dB	dB/m	dB	dBμV	dBμV/m	dBμV/m	dB	
5150.000	3.85	37.51	32.60	36.91	45.67	54.00	-8.33	AVG

**Remark:**

According to KDB 789033 section g (2), for measurement above 1000MHz @3m distance, out-of-band emission that complies with both the peak and average limits of § 15.209 is not required to satisfy the -27 dBm/MHz or -17 dBm/MHz maximum emission limit.

Job No.:	0116061074I	Plarization:	Vertical-AV
Standard:	(RE)FCC PART15 E_3m	Power Source:	AC 120V, 60Hz for adapter
Test item:	Radiation Test	Temp.(C)/Hum.(%RH):	24.3(C)/55%RH
Test Mode:	IEEE 802.11n(HT20) (5180MHz)	Distance:	3m

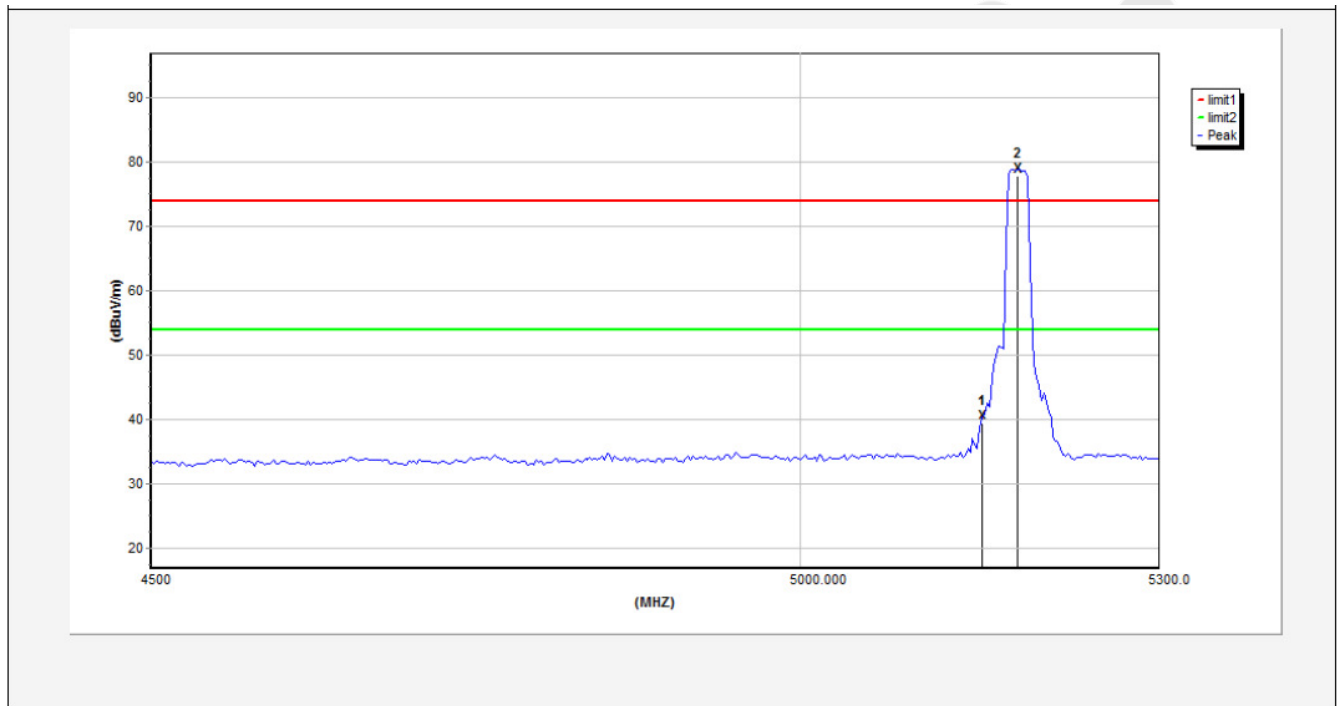

Frequency	CableLoss	AntFactor	PreampFactor	ReadLevel	Level	Limit	Over Limit	Remark
MHz	dB	dB/m	dB	dBμV	dBμV/m	dBμV/m	dB	
5150.000	3.85	37.51	32.60	32.47	41.23	54.00	-12.77	AVG

Remark:

According to KDB 789033 section g (2), for measurement above 1000MHz @3m distance, out-of-band emission that complies with both the peak and average limits of § 15.209 is not required to satisfy the -27 dBm/MHz or -17 dBm/MHz maximum emission limit.

Job No.:	0116061074I	Plarization:	Horizontal-PEAK
Standard:	(RE)FCC PART15 E_3m	Power Source:	AC 120V, 60Hz for adapter
Test item:	Radiation Test	Temp.(C)/Hum.(%RH):	24.3(C)/55% RH
Test Mode:	IEEE 802.11n(HT20) (5240MHz)	Distance:	3m

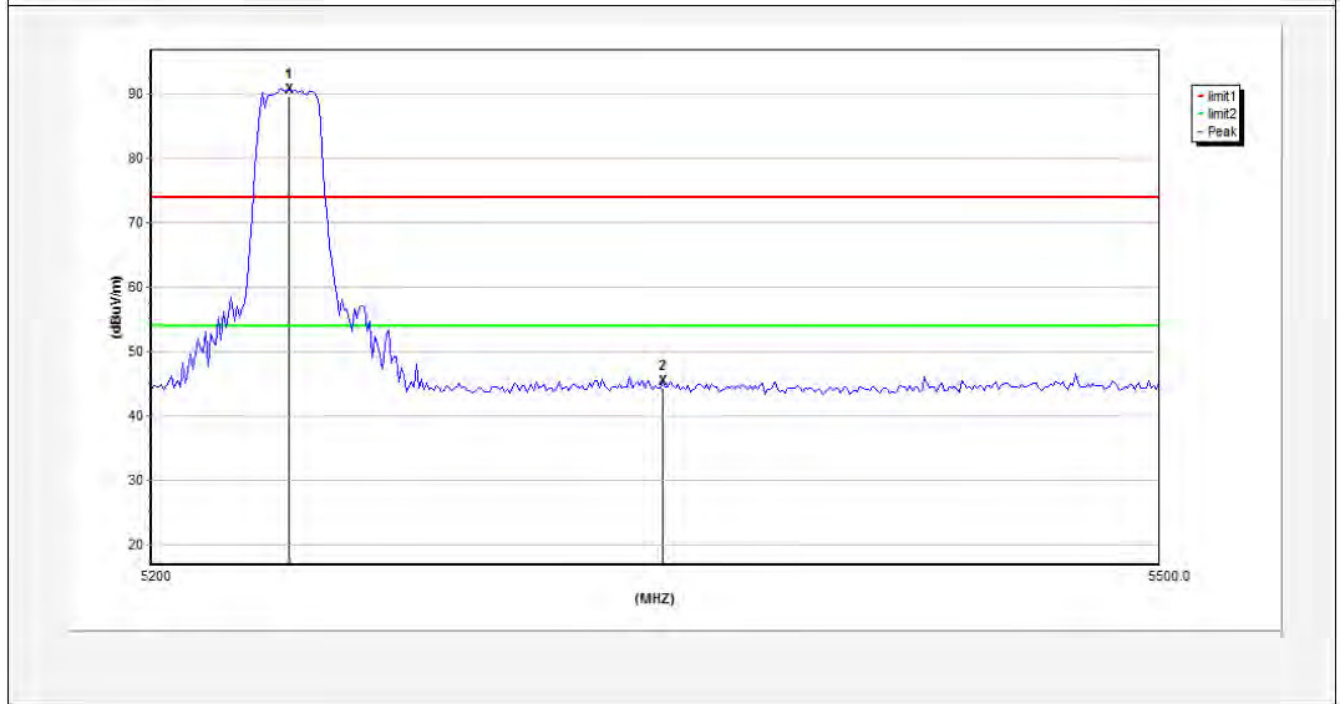

Frequency	CableLoss	AntFactor	PreampFactor	ReadLevel	Level	Limit	Over Limit	Remark
MHz	dB	dB/m	dB	dBµV	dBµV/m	dBµV/m	dB	
5350.000	3.87	37.59	32.60	37.38	46.24	74.00	-27.76	Peak

**Remark:**

According to KDB 789033 section g (2), for measurement above 1000MHz @3m distance, out-of-band emission that complies with both the peak and average limits of § 15.209 is not required to satisfy the -27 dBm/MHz or -17 dBm/MHz maximum emission limit.



Job No.:	0116061074I	Polarization:	Vertical-PEAK
Standard:	(RE)FCC PART15 E_3m	Power Source:	AC 120V, 60Hz for adapter
Test item:	Radiation Test	Temp.(C)/Hum.(%RH):	24.3(C)/55% RH
Test Mode:	IEEE 802.11n(HT20) (5240MHz)	Distance:	3m

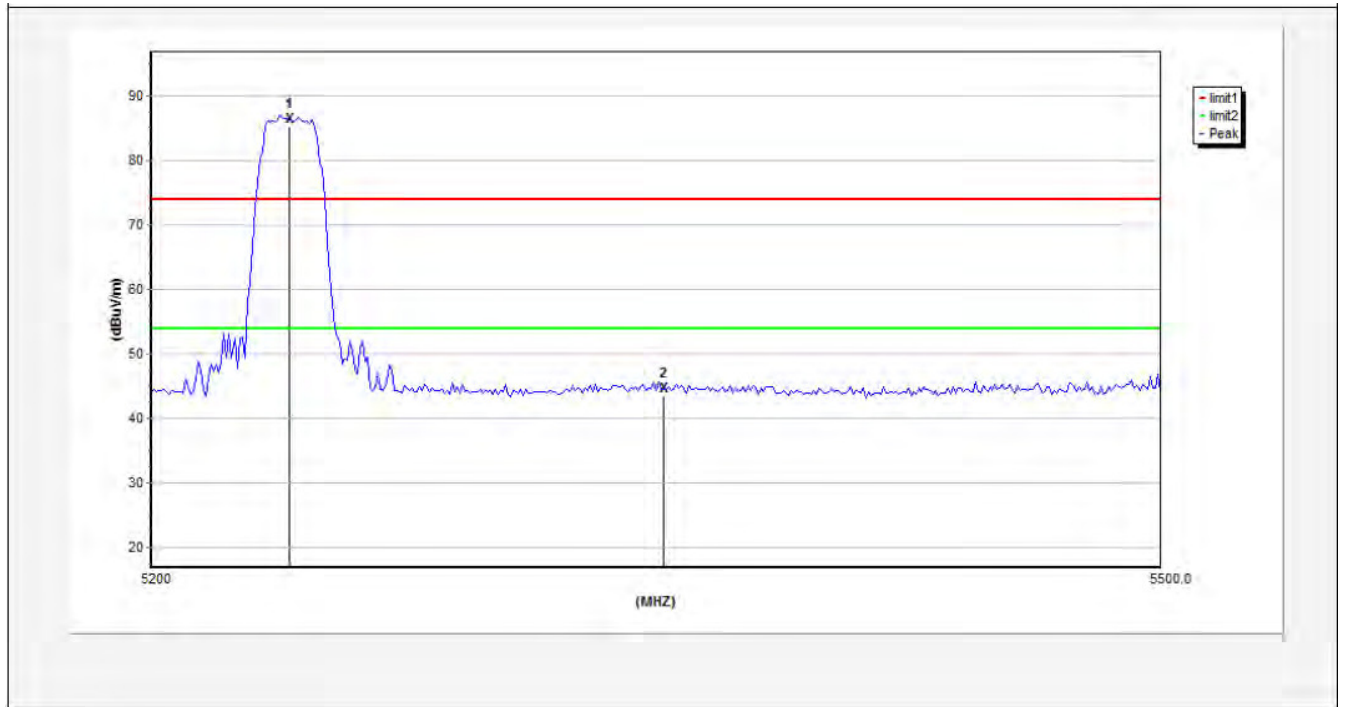

Frequency	CableLoss	AntFactor	PreampFactor	ReadLevel	Level	Limit	Over Limit	Remark
MHz	dB	dB/m	dB	dBμV	dBμV/m	dBμV/m	dB	
5350.000	3.87	37.59	32.60	38.19	47.05	74.00	-26.95	Peak

**Remark:**

According to KDB 789033 section g (2), for measurement above 1000MHz @3m distance, out-of-band emission that complies with both the peak and average limits of § 15.209 is not required to satisfy the -27 dBm/MHz or -17 dBm/MHz maximum emission limit.

Job No.:	0116061074I	Plarization:	Horizontal-AV
Standard:	(RE)FCC PART15 E_3m	Power Source:	AC 120V, 60Hz for adapter
Test item:	Radiation Test	Temp.(C)/Hum.(%RH):	24.3(C)/55% RH
Test Mode:	IEEE 802.11n(HT20) (5240MHz)	Distance:	3m

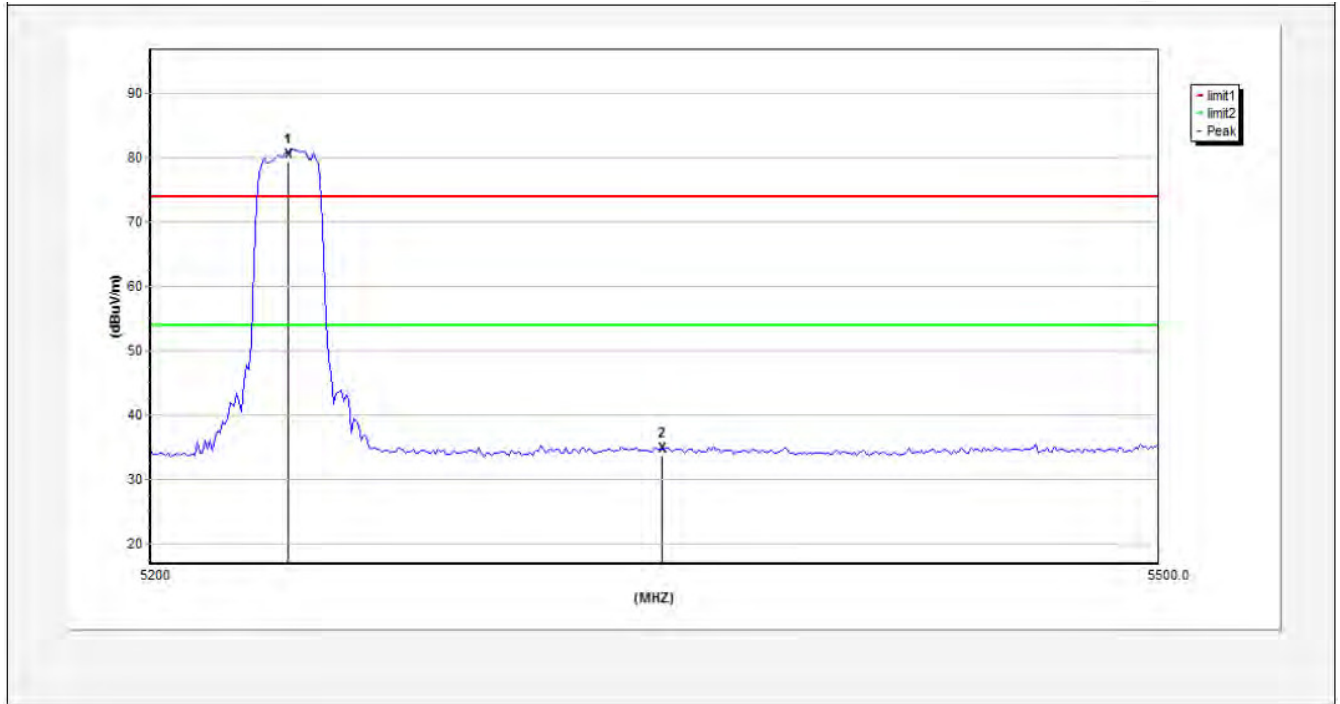

Frequency	CableLoss	AntFactor	PreampFactor	ReadLevel	Level	Limit	Over Limit	Remark
MHz	dB	dB/m	dB	dBμV	dBμV/m	dBμV/m	dB	
5350.000	3.85	37.51	32.60	29.88	38.64	54.00	-15.36	AVG

**Remark:**

According to KDB 789033 section g (2), for measurement above 1000MHz @3m distance, out-of-band emission that complies with both the peak and average limits of § 15.209 is not required to satisfy the -27 dBm/MHz or -17 dBm/MHz maximum emission limit.

Job No.:	0116061074I	Plarization:	Vertical-AV
Standard:	(RE)FCC PART15 E_3m	Power Source:	AC 120V, 60Hz for adapter
Test item:	Radiation Test	Temp.(C)/Hum.(%RH):	24.3(C)/55%RH
Test Mode:	IEEE 802.11n(HT20) (5240MHz)	Distance:	3m

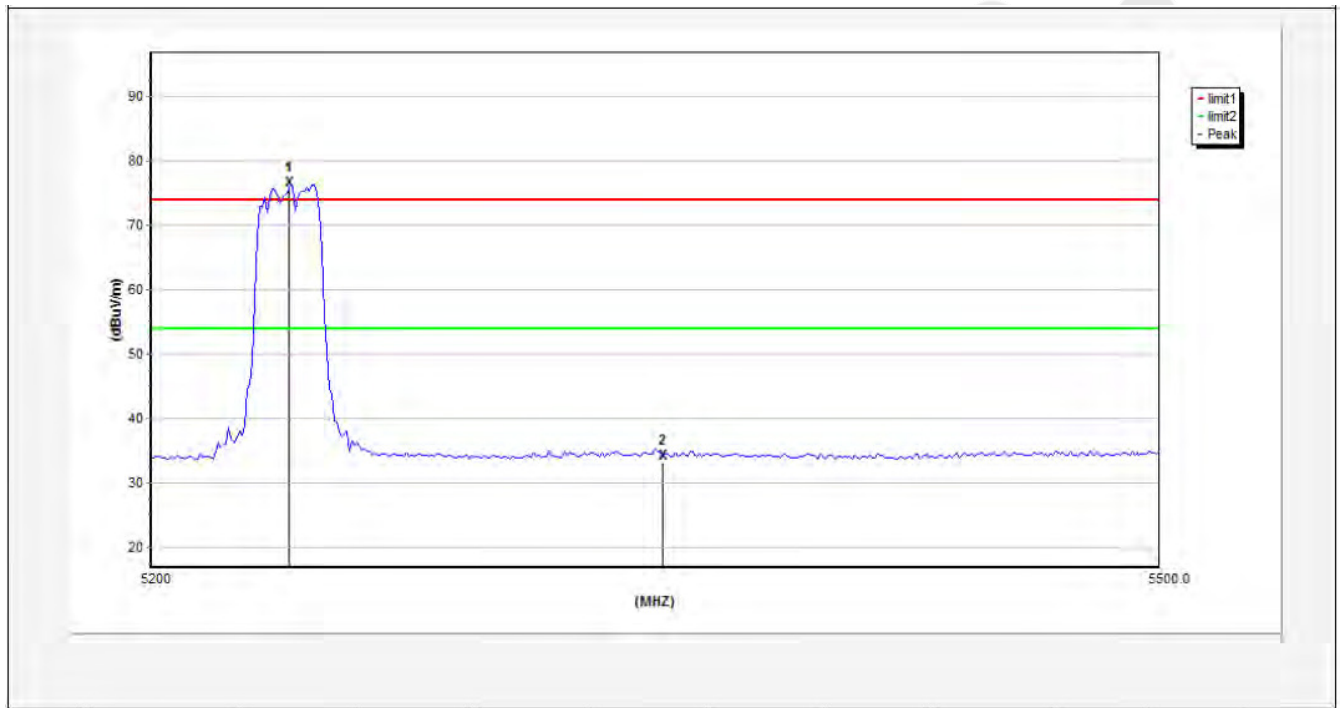

Frequency	CableLoss	AntFactor	PreampFactor	ReadLevel	Level	Limit	Over Limit	Remark
MHz	dB	dB/m	dB	dB $\mu$ V	dB $\mu$ V/m	dB $\mu$ V/m	dB	
5350.000	3.85	37.51	32.60	30.17	38.93	54.00	-15.07	AVG

**Remark:**

According to KDB 789033 section g (2), for measurement above 1000MHz @3m distance, out-of-band emission that complies with both the peak and average limits of § 15.209 is not required to satisfy the -27 dBm/MHz or -17 dBm/MHz maximum emission limit.

Job No.:	0116061074I	Plarization:	Horizontal-PEAK
Standard:	(RE)FCC PART15 E_3m	Power Source:	AC 120V, 60Hz for adapter
Test item:	Radiation Test	Temp.(C)/Hum.(%RH):	24.3(C)/55% RH
Test Mode:	IEEE 802.11n(HT20) (5745MHz)	Distance:	3m

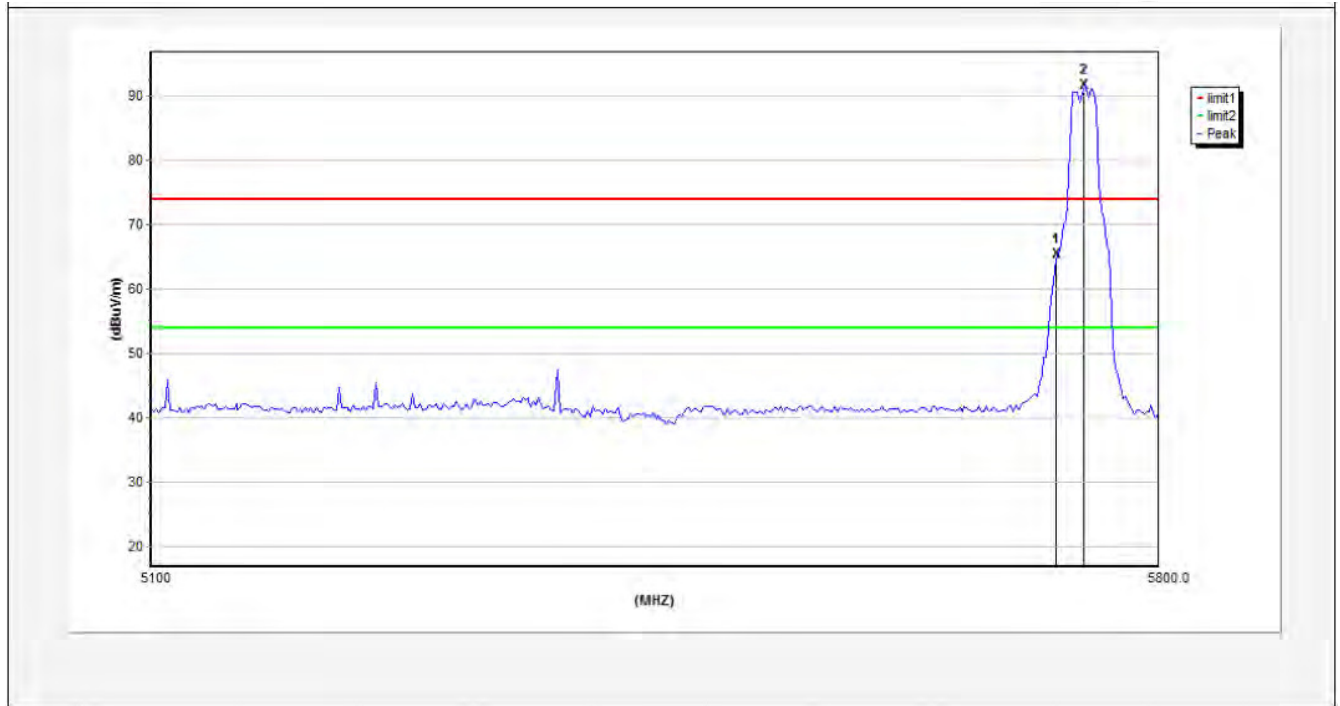

Frequency	CableLoss	AntFactor	PreampFactor	ReadLevel	Level	Limit	Over Limit	Remark
MHz	dB	dB/m	dB	dBμV	dBμV/m	dBμV/m	dB	
5725.000	3.92	37.63	32.60	57.22	66.17	74.00	-7.83	Peak

**Remark:**

According to KDB 789033 section g (2), for measurement above 1000MHz @3m distance, out-of-band emission that complies with both the peak and average limits of § 15.209 is not required to satisfy the -27 dBm/MHz or -17 dBm/MHz maximum emission limit.

Job No.:	0116061074I	Plarization:	Vertical-PEAK
Standard:	(RE)FCC PART15 E_3m	Power Source:	AC 120V, 60Hz for adapter
Test item:	Radiation Test	Temp.(C)/Hum.(%RH):	24.3(C)/55% RH
Test Mode:	IEEE 802.11n(HT20) (5745MHz)	Distance:	3m

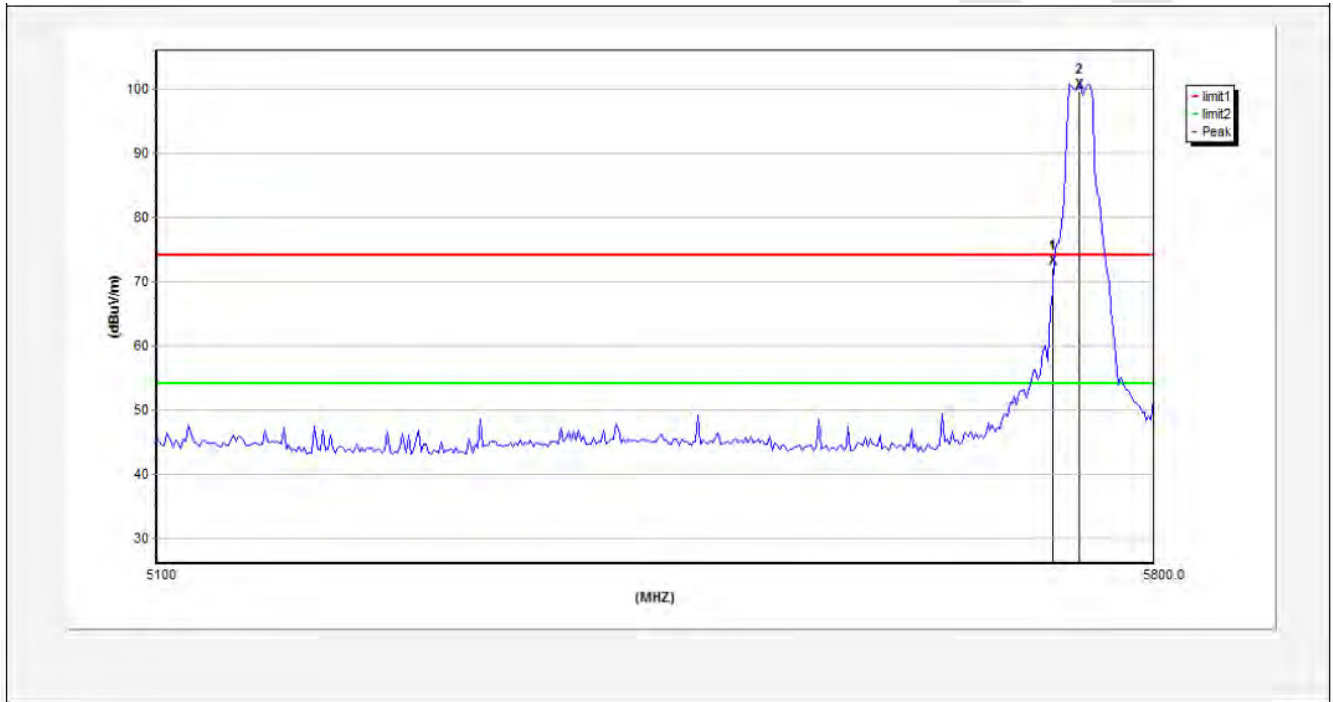

Frequency	CableLoss	AntFactor	Preamplifier	ReadLevel	Level	Limit	Over Limit	Remark
MHz	dB	dB/m	dB	dBμV	dBμV/m	dBμV/m	dB	
5725.000	3.92	37.63	32.60	63.67	72.62	74.00	-1.38	Peak

**Remark:**

According to KDB 789033 section g (2), for measurement above 1000MHz @3m distance, out-of-band emission that complies with both the peak and average limits of § 15.209 is not required to satisfy the -27 dBm/MHz or -17 dBm/MHz maximum emission limit.

Job No.:	0116061074I	Plarization:	Horizontal-AV
Standard:	(RE)FCC PART15 E_3m	Power Source:	AC 120V, 60Hz for adapter
Test item:	Radiation Test	Temp.(C)/Hum.(%RH):	24.3(C)/55% RH
Test Mode:	IEEE 802.11n(HT20) (5745MHz)	Distance:	3m

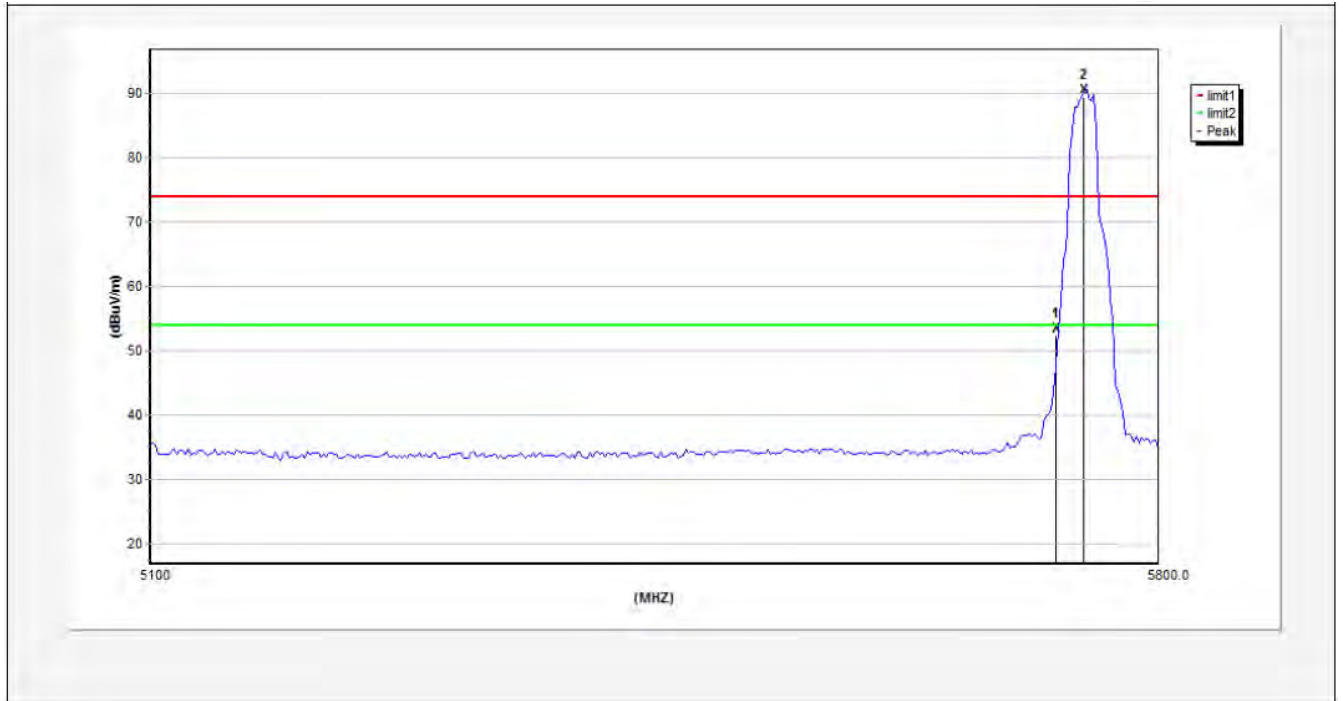

Frequency	CableLoss	AntFactor	Preamplifier	ReadLevel	Level	Limit	Over Limit	Remark
MHz	dB	dB/m	dB	dBμV	dBμV/m	dBμV/m	dB	
5725.000	3.92	37.63	32.60	44.27	53.22	54.00	-0.78	AVG

**Remark:**

According to KDB 789033 section g (2), for measurement above 1000MHz @3m distance, out-of-band emission that complies with both the peak and average limits of § 15.209 is not required to satisfy the -27 dBm/MHz or -17 dBm/MHz maximum emission limit.



Job No.:	0116061074I	Plarization:	Vertical-AV
Standard:	(RE)FCC PART15 E_3m	Power Source:	AC 120V, 60Hz for adapter
Test item:	Radiation Test	Temp.(C)/Hum.(%RH):	24.3(C)/55% RH
Test Mode:	IEEE 802.11n(HT20) (5745MHz)	Distance:	3m

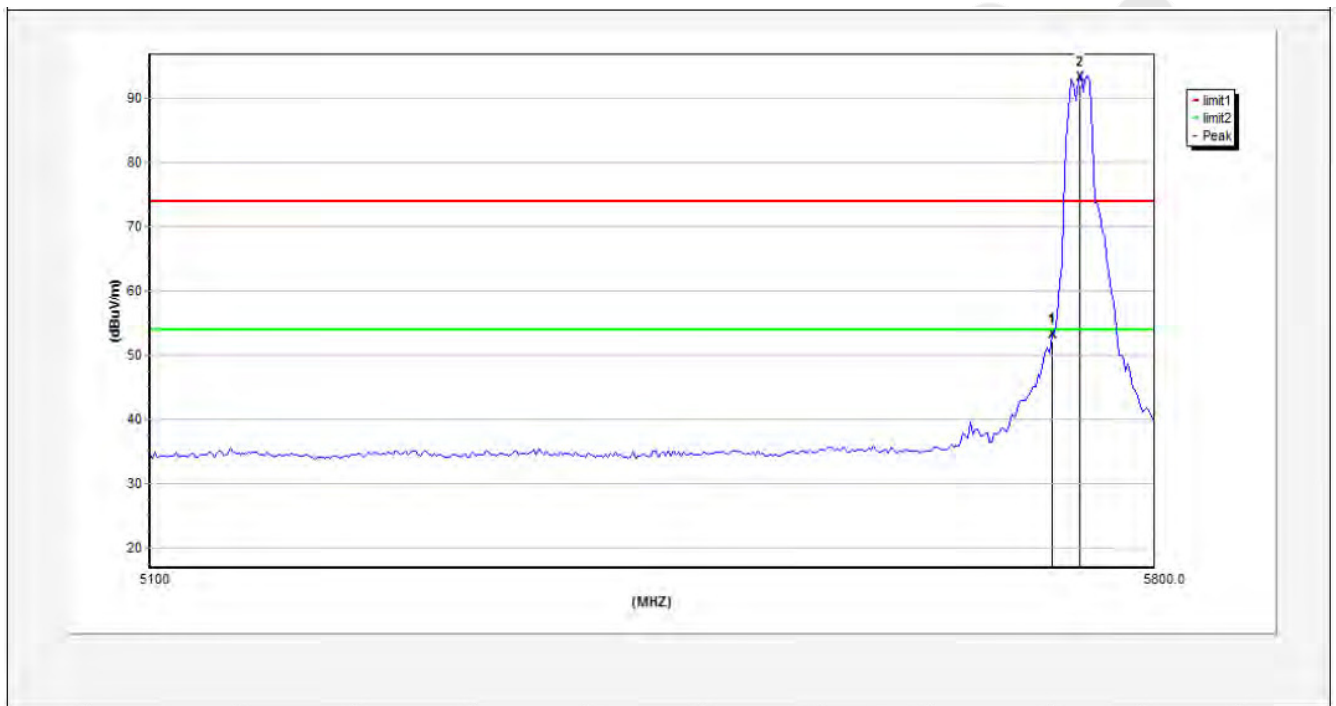

Frequency	CableLoss	AntFactor	PreampFactor	ReadLevel	Level	Limit	Over Limit	Remark
MHz	dB	dB/m	dB	dBµV	dBµV/m	dBµV/m	dB	
5725.000	3.92	37.63	32.60	44.21	53.16	54.00	-0.84	AVG

**Remark:**

According to KDB 789033 section g (2), for measurement above 1000MHz @3m distance, out-of-band emission that complies with both the peak and average limits of § 15.209 is not required to satisfy the -27 dBm/MHz or -17 dBm/MHz maximum emission limit.

Job No.:	0116061074I	Plarization:	Horizontal-PEAK
Standard:	(RE)FCC PART15 E_3m	Power Source:	AC 120V, 60Hz for adapter
Test item:	Radiation Test	Temp.(C)/Hum. (%RH):	24.3(C)/55% RH
Test Mode:	IEEE 802.11n(HT20) (5825MHz)	Distance:	3m

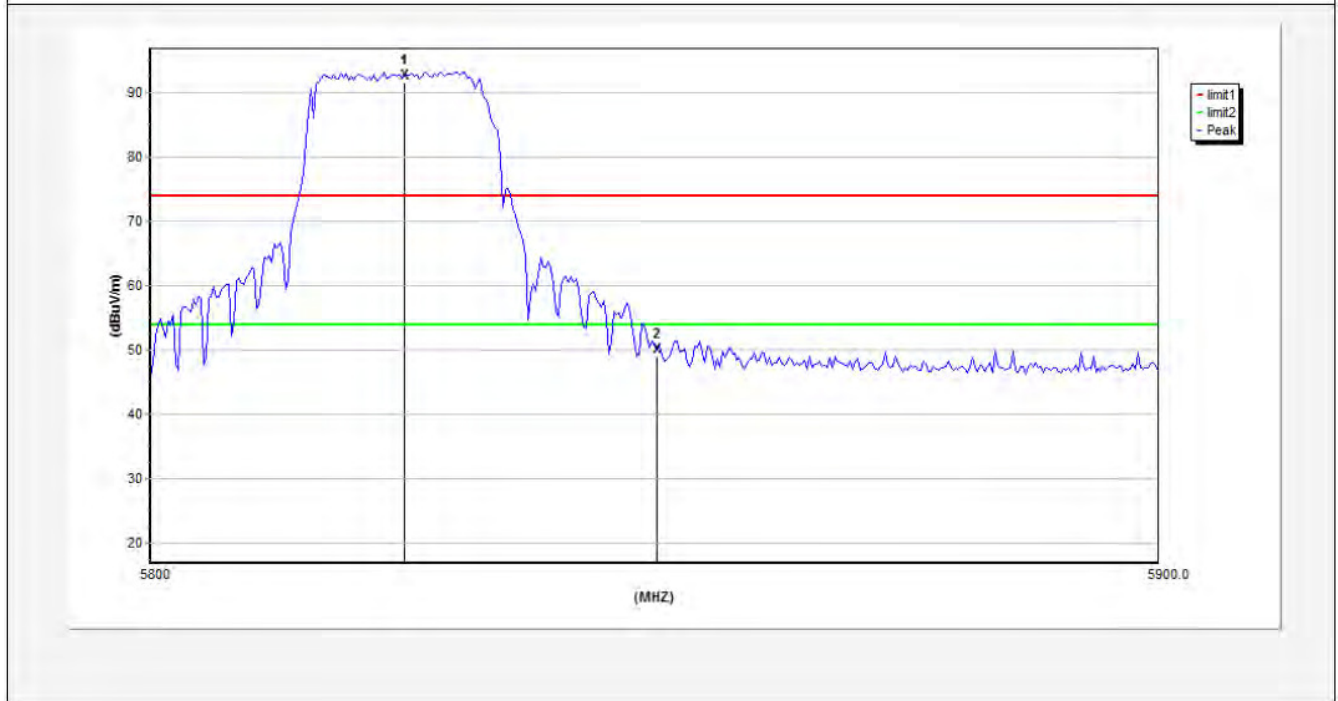

Frequency	CableLoss	AntFactor	PreampFactor	ReadLevel	Level	Limit	Over Limit	Remark
MHz	dB	dB/m	dB	dBμV	dBμV/m	dBμV/m	dB	
5850.000	3.95	37.67	32.60	43.29	52.31	74.00	-21.69	Peak

**Remark:**

According to KDB 789033 section g (2), for measurement above 1000MHz @3m distance, out-of-band emission that complies with both the peak and average limits of § 15.209 is not required to satisfy the -27 dBm/MHz or -17 dBm/MHz maximum emission limit.

Job No.:	0116061074I	Plarization:	Vertical-PEAK
Standard:	(RE)FCC PART15 E_3m	Power Source:	AC 120V, 60Hz for adapter
Test item:	Radiation Test	Temp.(C)/Hum.(%RH):	24.3(C)/55% RH
Test Mode:	IEEE 802.11n(HT20) (5825MHz)	Distance:	3m

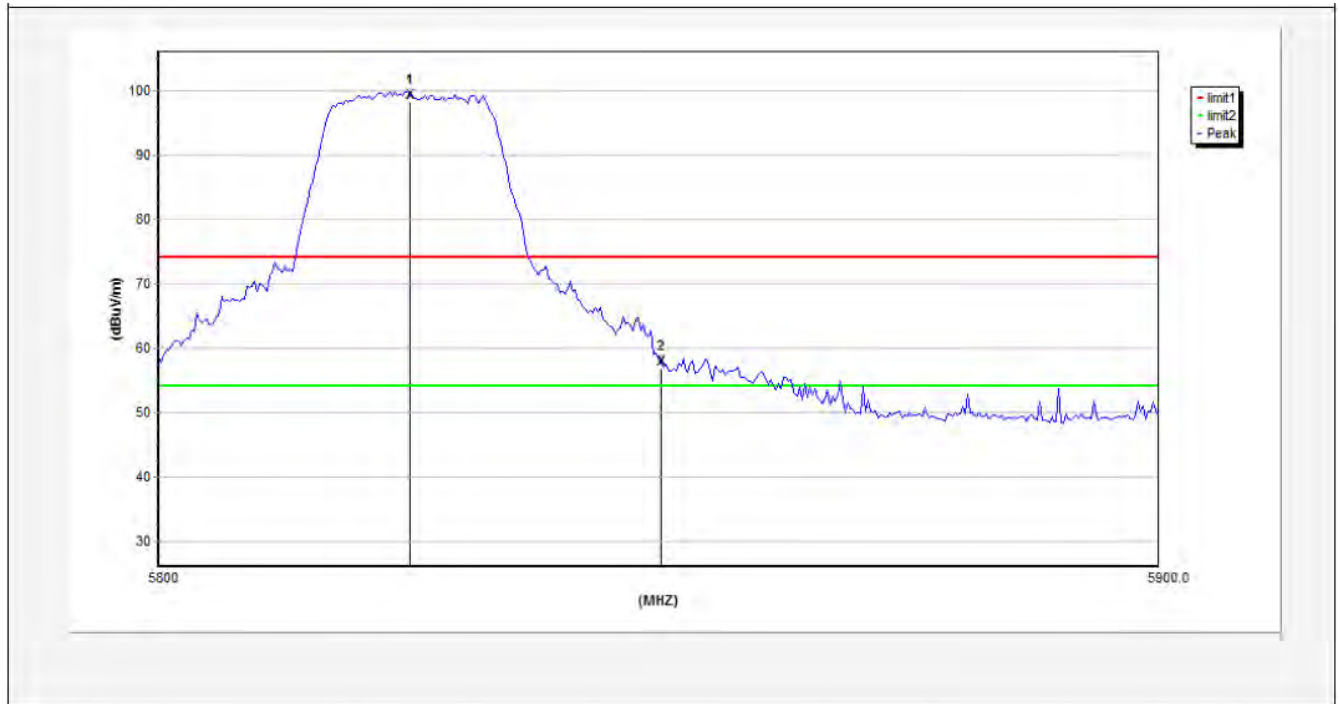

Frequency	CableLoss	AntFactor	PreampFactor	ReadLevel	Level	Limit	Over Limit	Remark
MHz	dB	dB/m	dB	dBμV	dBμV/m	dBμV/m	dB	
5850.000	3.95	37.67	32.60	48.85	57.87	74.00	-16.13	Peak

**Remark:**

According to KDB 789033 section g (2), for measurement above 1000MHz @3m distance, out-of-band emission that complies with both the peak and average limits of § 15.209 is not required to satisfy the -27 dBm/MHz or -17 dBm/MHz maximum emission limit.

Job No.:	0116061074I	Plarization:	Horizontal-AV
Standard:	(RE)FCC PART15 E_3m	Power Source:	AC 120V, 60Hz for adapter
Test item:	Radiation Test	Temp.(C)/Hum.(%RH):	24.3(C)/55% RH
Test Mode:	IEEE 802.11n(HT20) (5825MHz)	Distance:	3m

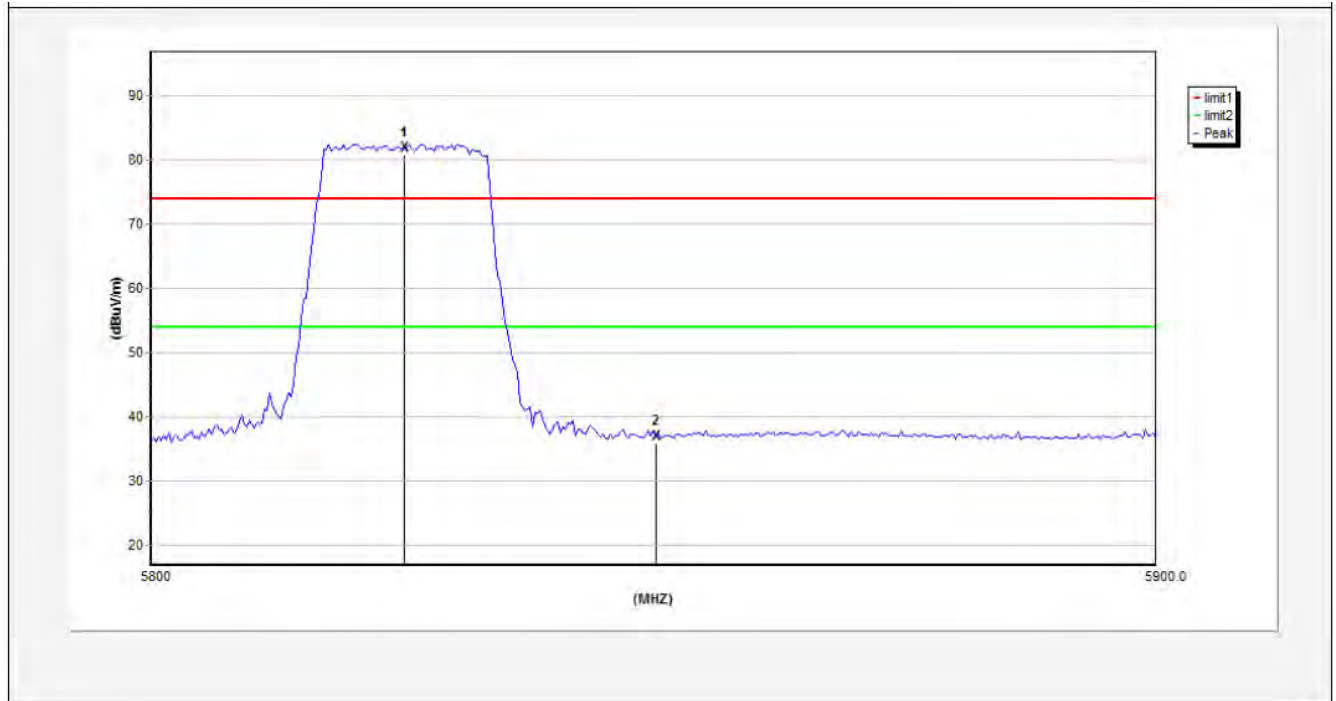

Frequency	CableLoss	AntFactor	PreampFactor	ReadLevel	Level	Limit	Over Limit	Remark
MHz	dB	dB/m	dB	dBμV	dBμV/m	dBμV/m	dB	
5850.000	3.95	37.67	32.60	30.23	39.25	54.00	-14.75	AVG

**Remark:**

According to KDB 789033 section g (2), for measurement above 1000MHz @3m distance, out-of-band emission that complies with both the peak and average limits of § 15.209 is not required to satisfy the -27 dBm/MHz or -17 dBm/MHz maximum emission limit.

<b>Job No.:</b>	<b>0116061074I</b>	<b>Plarization:</b>	<b>Vertical-AV</b>
<b>Standard:</b>	<b>(RE)FCC PART15 E_3m</b>	<b>Power Source:</b>	<b>AC 120V, 60Hz for adapter</b>
<b>Test item:</b>	<b>Radiation Test</b>	<b>Temp.(C)/Hum.(%RH):</b>	<b>24.3(C)/55%RH</b>
<b>Test Mode:</b>	<b>IEEE 802.11n(HT20) (5825MHz)</b>	<b>Distance:</b>	<b>3m</b>

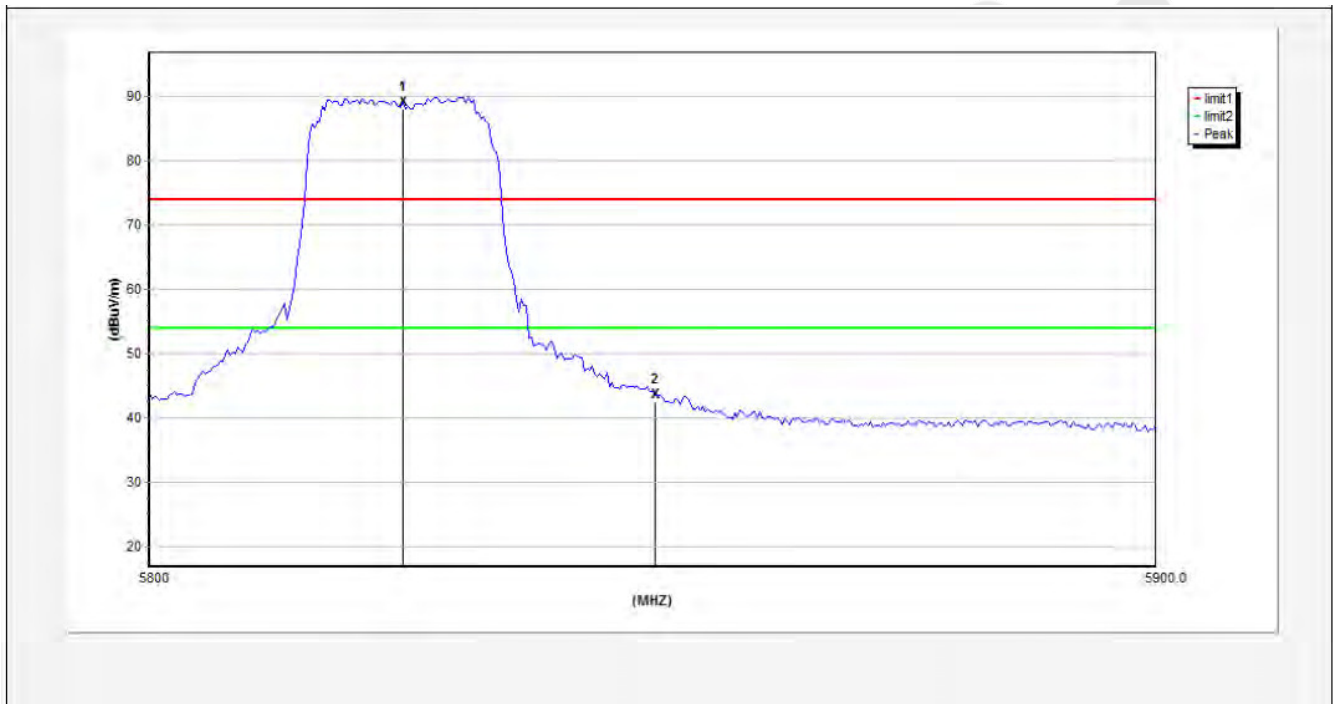

Frequency	CableLoss	AntFactor	PreampFactor	ReadLevel	Level	Limit	Over Limit	Remark
MHz	dB	dB/m	dB	dBμV	dBμV/m	dBμV/m	dB	
5850.000	3.95	37.67	32.60	36.60	45.62	54.00	-8.38	AVG

**Remark:**

According to KDB 789033 section g (2), for measurement above 1000MHz @3m distance, out-of-band emission that complies with both the peak and average limits of § 15.209 is not required to satisfy the -27 dBm/MHz or -17 dBm/MHz maximum emission limit.

## 9. ANTENNA APPLICATION

### 9.1. Antenna requirement

The EUT'S antenna is met the requirement of FCC part 15C section 15.407.

An intentional radiator shall be designed to ensure that no antenna other than that furnished by the responsible party shall be used with the device. The use of a permanently attached antenna or of an antenna that uses a unique coupling to the intentional radiator shall be considered sufficient to comply with the provisions of this section. The manufacturer may design the unit so that a broken antenna can be replaced by the user, but the use of a standard antenna jack or electrical connector is prohibited. This requirement does not apply to carrier current devices or to devices operated under the provisions of §15.211, §15.213, §15.217, §15.219, or §15.221. Further, this requirement does not apply to intentional radiators that must be professionally installed, such as perimeter protection systems and some field disturbance sensors, or to other intentional radiators which, in accordance with §15.31(d), must be measured at the installation site. However, the installer shall be responsible for ensuring that the proper antenna is employed so that the limits in this part are not exceeded.

### 9.2. Result

The EUT's antenna used a external antenna which is permanently attached, The antenna's gain is 4.75dBi and meets the requirement.

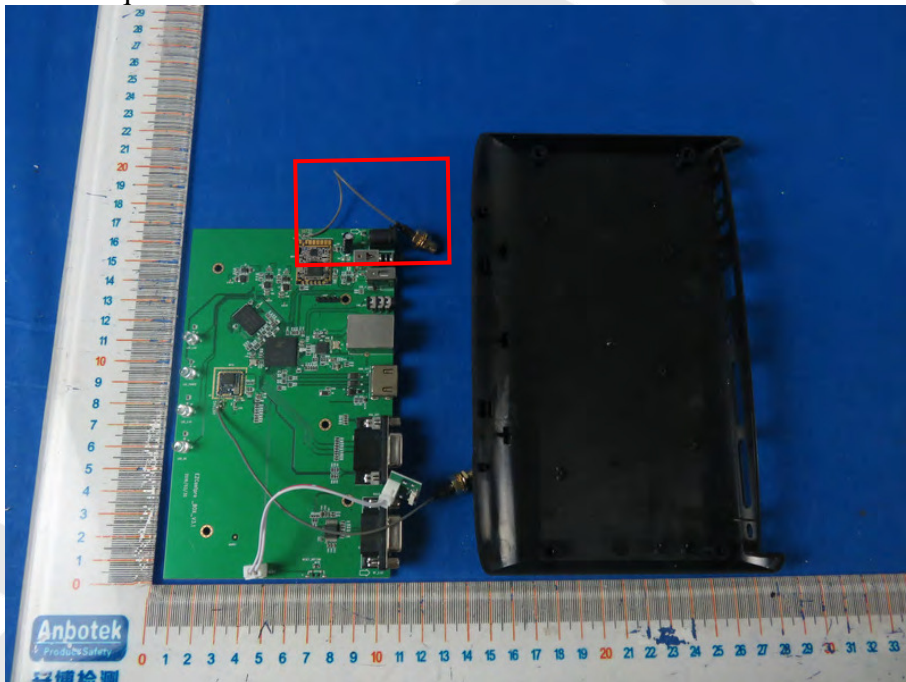



## 10. PHOTOGRAPH

### 10.1. Photo of Conducted Emission Measurement

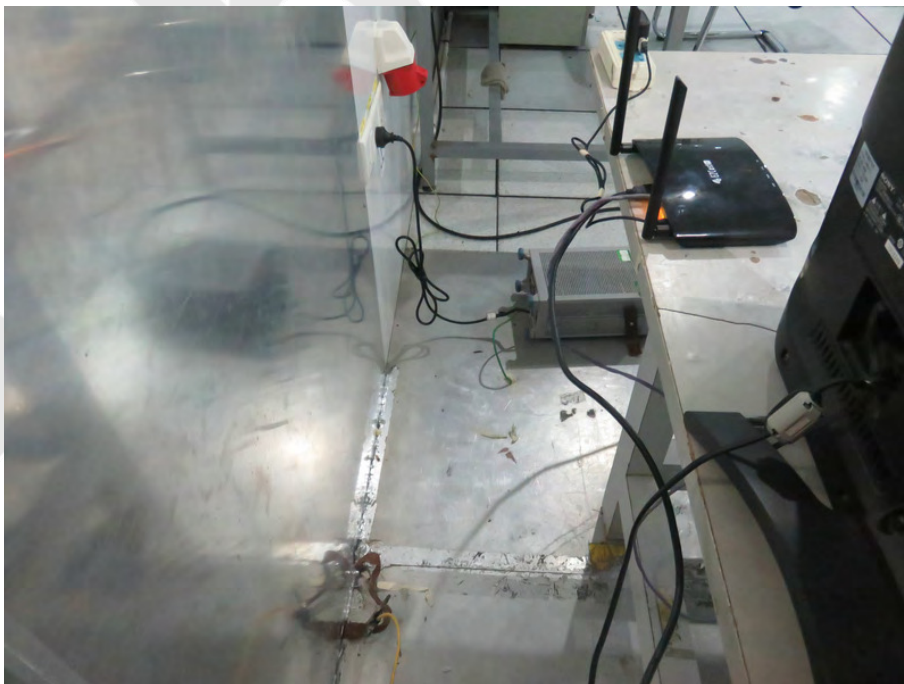

### 10.2. Photo of Radiation Emission Test



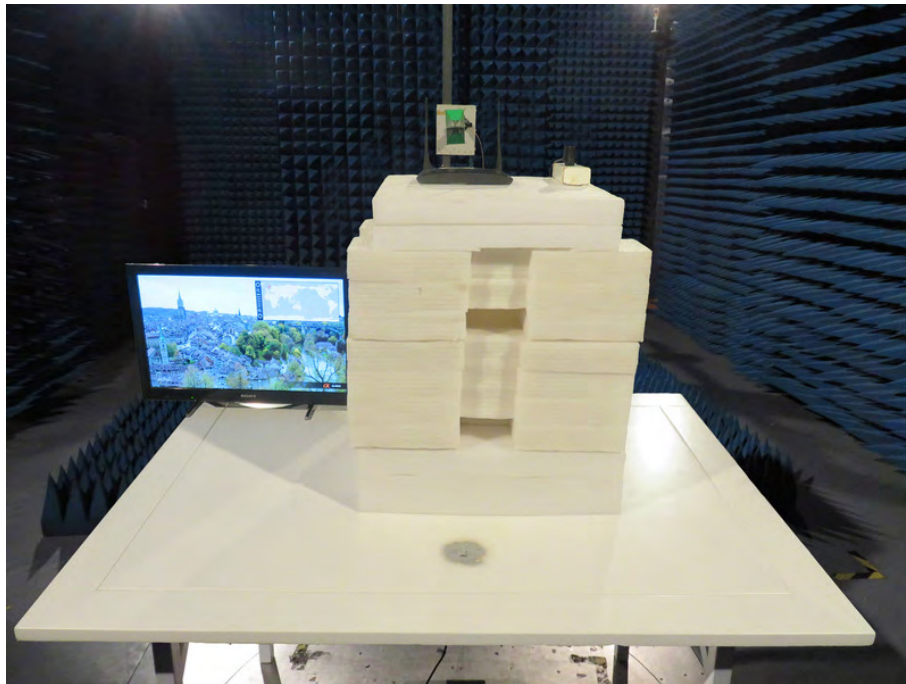

Anbotek



## APPENDIX I (EXTERNAL PHOTOS)

1. Figure  
The EUT-Overall View



2. Figure  
The EUT-Top View



3. Figure  
The EUT-Bottom View



4. Figure  
The EUT-Front View



5. Figure  
The EUT-Back View

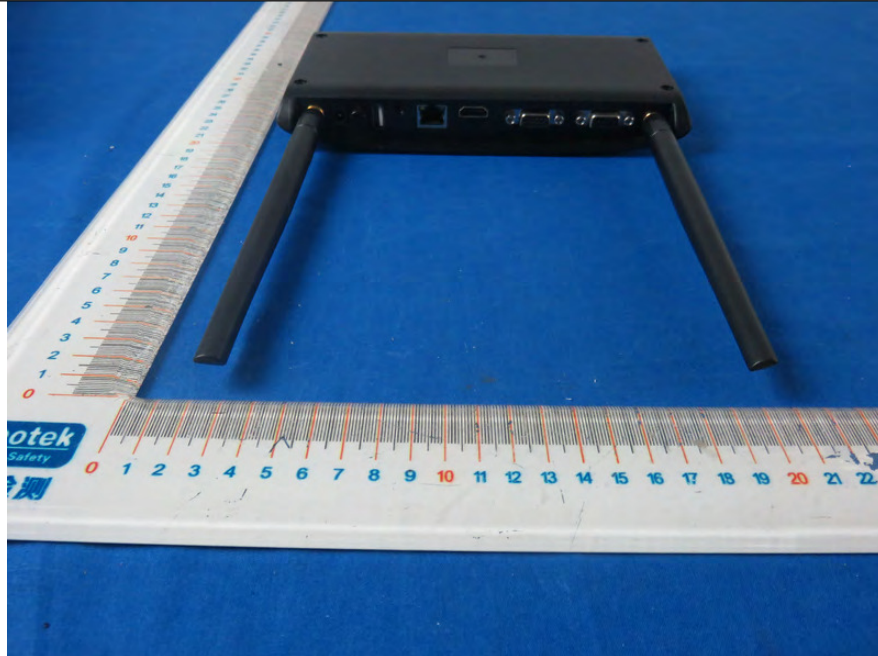

6. Figure  
The EUT-Right View

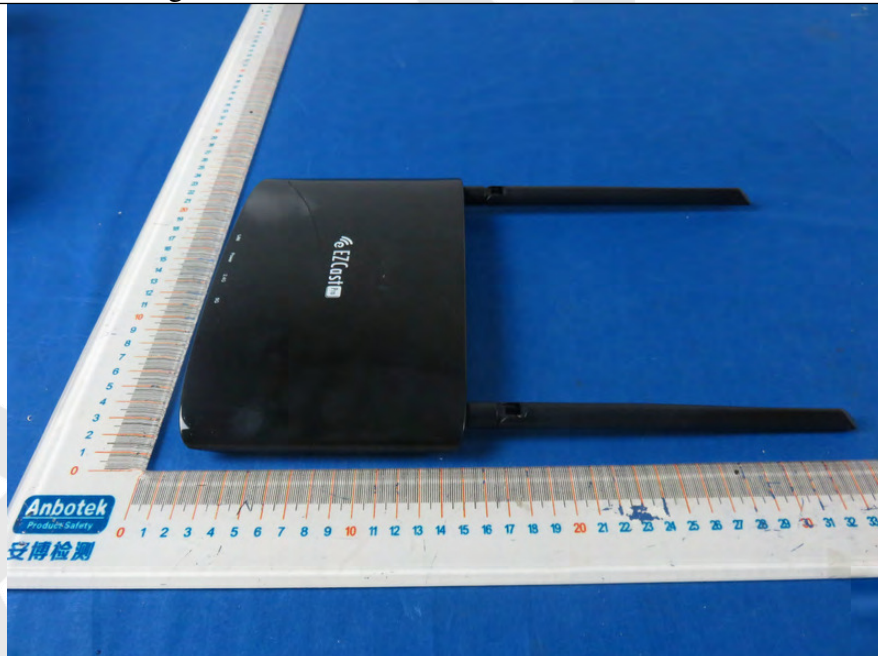



7. Figure  
The EUT-Left View



## APPENDIX II (INTERNAL PHOTOS)

1. Figure  
The EUT-Inside View



2. Figure  
The EUT-Inside View



3. Figure  
PCB of the EUT-Front View

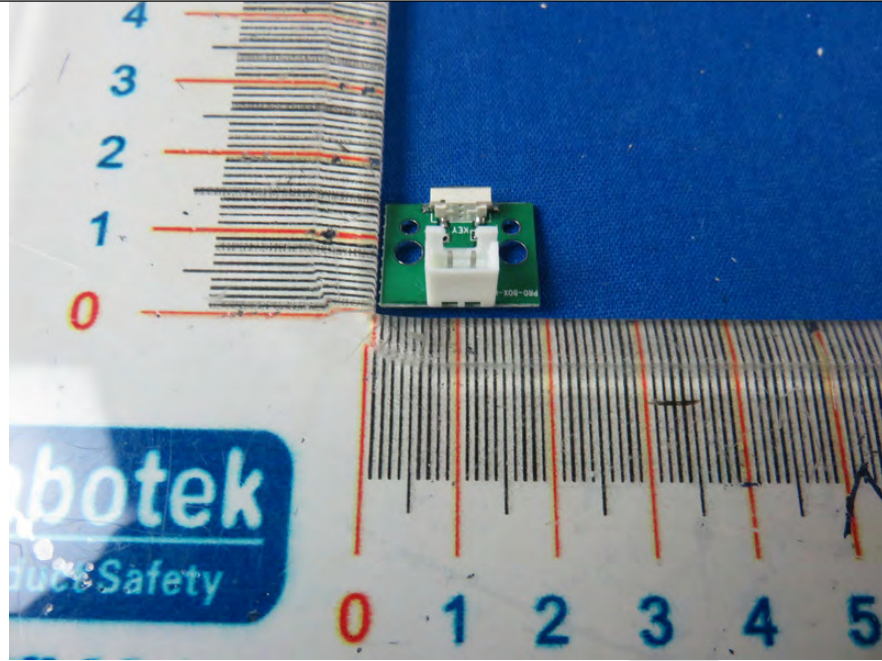

4. Figure  
PCB of the EUT-Back View

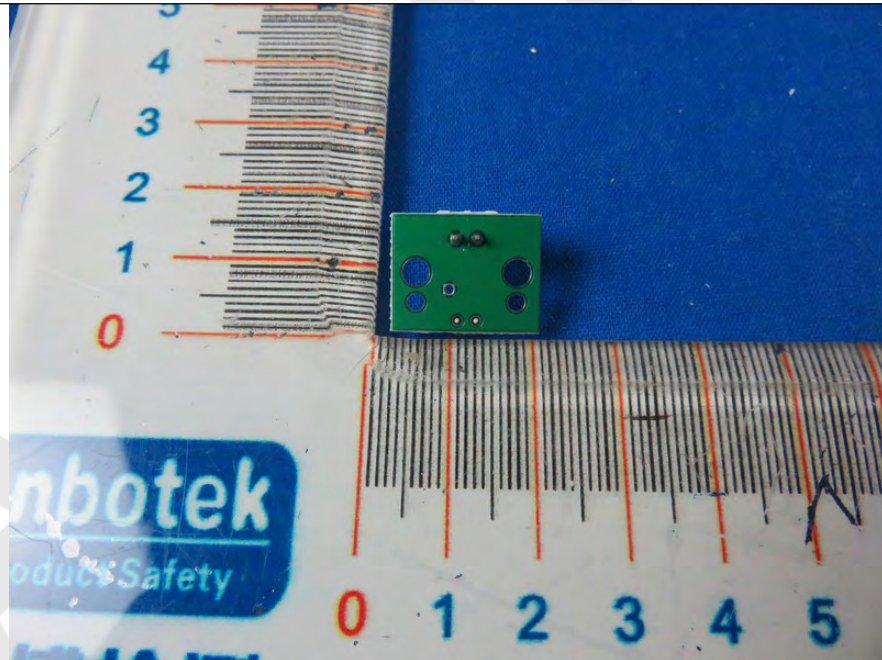



5. Figure  
PCB of the EUT-Front View

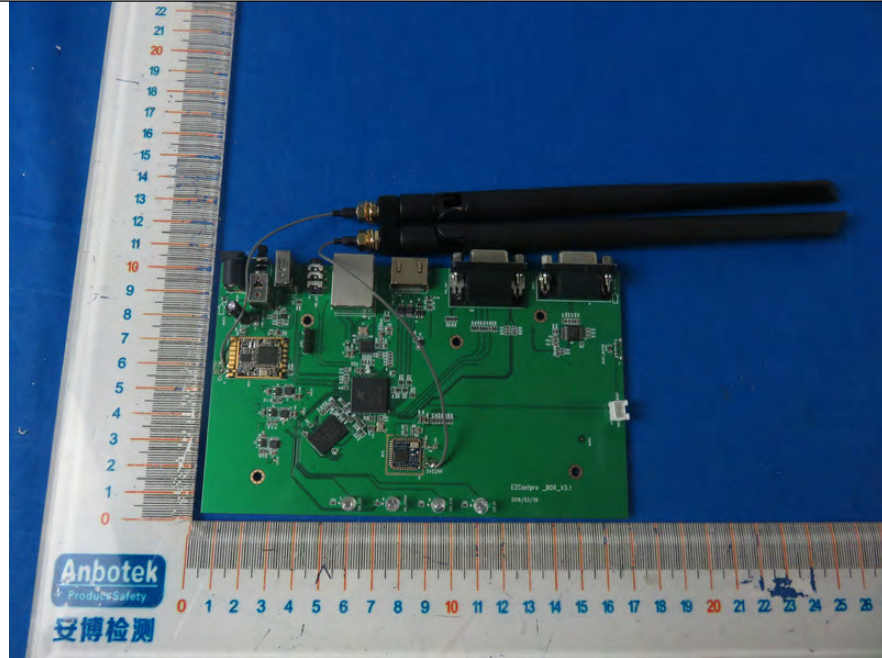

6. Figure  
PCB of the EUT-Back View

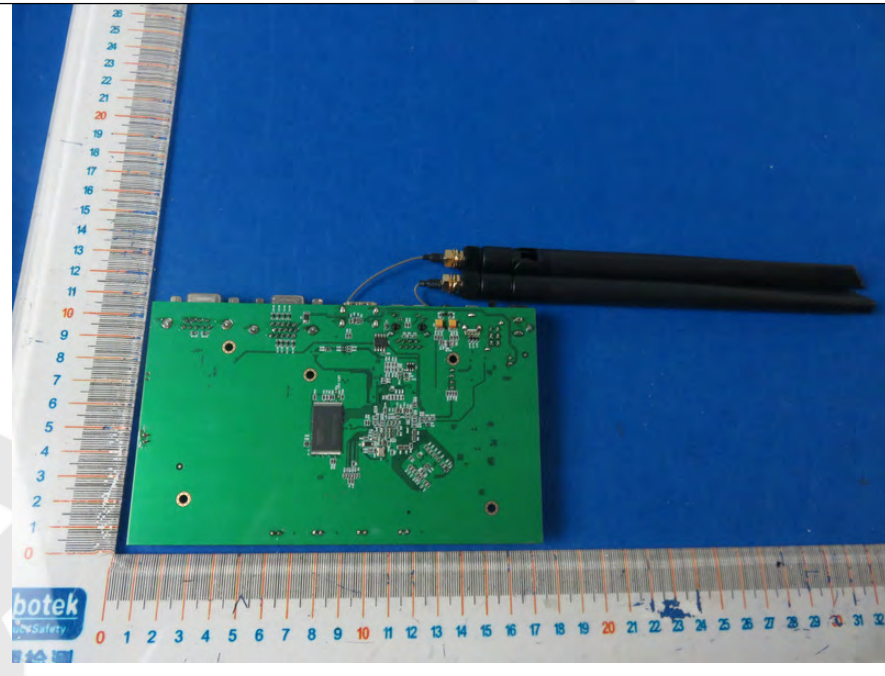

7. Figure  
PCB of the EUT-Front View (5G Module)



8. Figure  
PCB of the EUT-Back View (5G Module)

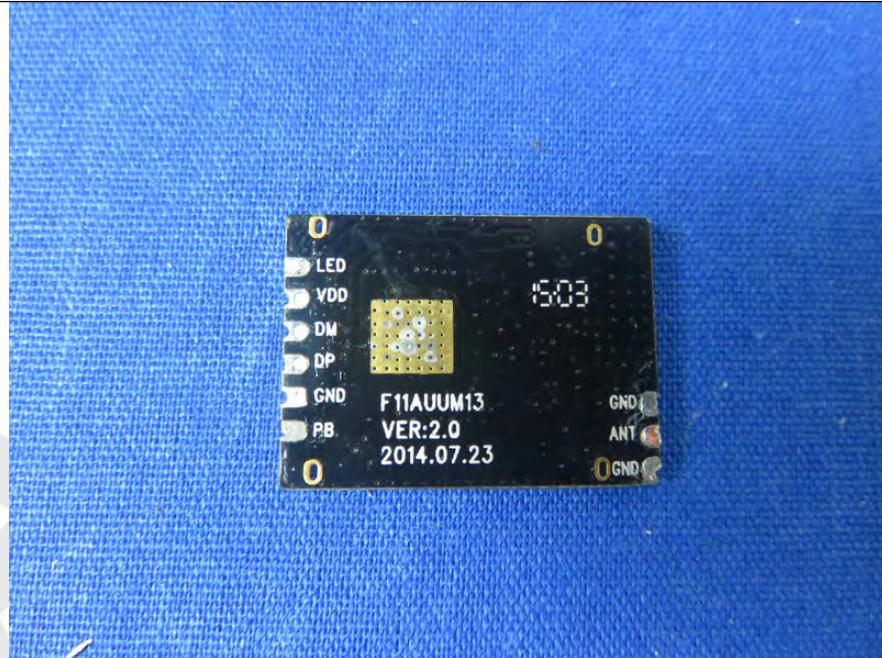



9. Figure  
PCB of the EUT-Front View (2.4G Module)

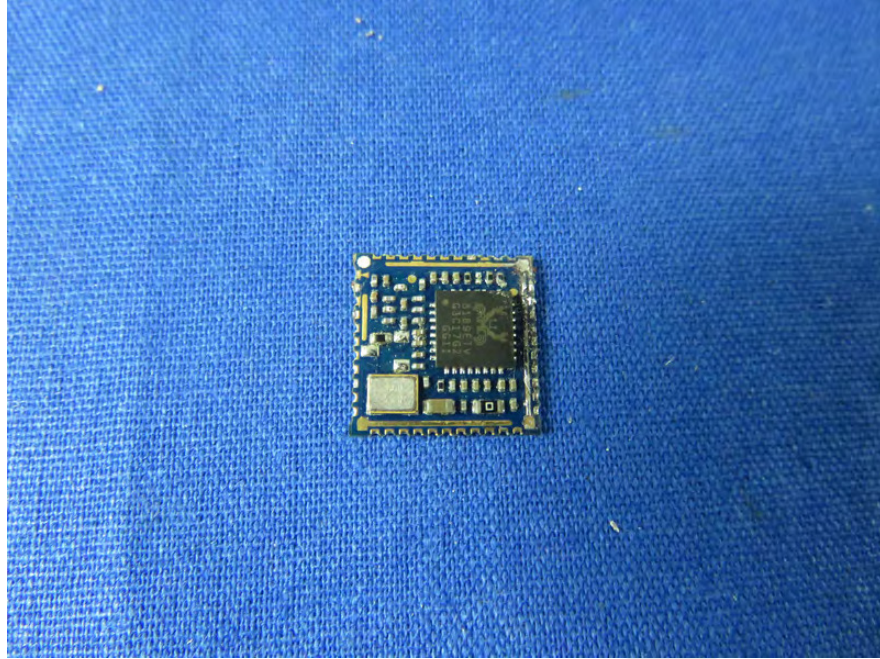

10. Figure  
PCB of the EUT-Back View (2.4G Module)

