



# FCC REPORT

**Report Reference No.**..... : **CHEW20020022** Report verification: 

**Project No.** ..... : **SHT1912068505EW**

**FCC ID**..... : **2ADE3NMC002**

**Applicant's name**..... : **WUXI IDATA TECHNOLOGY COMPANY LTD.**

**Address**..... : Floor 11,Building B1,Wuxi Binhu National Sensing Information Center,No.999 Gaolang East Road,Wuxi ,China

**Manufacturer**..... : WUXI IDATA TECHNOLOGY COMPANY LTD.

**Address**..... : Floor 11,Building B1,Wuxi Binhu National Sensing Information Center,No.999 Gaolang East Road,Wuxi ,China

**Test item description** ..... : **New Mobile Computer**

**Trade Mark** ..... : iData

**Model/Type reference**..... : iData 50

**Listed Model(s)** ..... : See page 3 of the report

**Standard** ..... : **FCC CFR Title 47 Part 2**  
**FCC CFR Title 47 Part 22**  
**FCC CFR Title 47 Part 24**  
**FCC CFR Title 47 Part 27**

**Date of receipt of test sample**..... : Dec.20, 2019

**Date of testing**..... : Dec.21, 2019- Feb.25, 2020

**Date of issue**..... : Feb.26, 2020

**Result**..... : **Pass**

Compiled by  
 ( position+printedname+signature).... : File administrators Fanghui Zhu

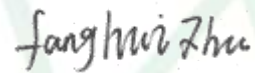

Supervised by  
 (position+printedname+signature).... : Project Engineer Edward Pan



Approved by  
 (position+printedname+signature).... : Manager Hans Hu

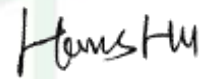

**Testing Laboratory Name** ..... : **Shenzhen Huatongwei International Inspection Co., Ltd.**

**Address**..... : 1/F, Bldg 3, Hongfa Hi-tech Industrial Park, Genyu Road, Tianliao, Gongming, Shenzhen, China

**Shenzhen Huatongwei International Inspection Co., Ltd. All rights reserved.**

This publication may be reproduced in whole or in part for non-commercial purposes as long as the Shenzhen Huatongwei International Inspection Co., Ltd. is acknowledged as copyright owner and source of the material. Shenzhen Huatongwei International Inspection Co., Ltd. takes no responsibility for and will not assume liability for damages resulting from the reader's interpretation of the reproduced material due to its placement and context.

*The test report merely correspond to the test sample.*

## Contents

<b>1.</b>	<b><u>TEST STANDARDS AND REPORT VERSION</u></b>	<b>3</b>
1.1.	Applicable Standards	3
1.2.	Report version information	3
<b>2.</b>	<b><u>TEST DESCRIPTION</u></b>	<b>4</b>
<b>3.</b>	<b><u>SUMMARY</u></b>	<b>5</b>
3.1.	Client Information	5
3.2.	Product Description	5
3.3.	Operation state	7
3.4.	EUT operation mode	9
3.5.	EUT configuration	10
3.6.	Modifications	10
<b>4.</b>	<b><u>TEST ENVIRONMENT</u></b>	<b>11</b>
4.1.	Address of the test laboratory	11
4.2.	Test Facility	11
4.3.	Equipments Used during the Test	12
4.4.	Environmental conditions	13
4.5.	Statement of the measurement uncertainty	13
<b>5.</b>	<b><u>TEST CONDITIONS AND RESULTS</u></b>	<b>14</b>
5.1.	Conducted Output Power	14
5.2.	Peak-to-Average Ratio	15
5.3.	99% Occupied Bandwidth & 26 dB Bandwidth	16
5.4.	Band Edge	17
5.5.	Conducted Spurious Emissions	18
5.6.	Frequency stability VS Temperature measurement	19
5.7.	Frequency stability VS Voltage measurement	20
5.8.	ERP and EIRP	21
5.9.	Radiated Spurious Emission	32
<b>6.</b>	<b><u>TEST SETUP PHOTOS OF THE EUT</u></b>	<b>49</b>
<b>7.</b>	<b><u>EXTERNAL AND INTERNAL PHOTOS OF THE EUT</u></b>	<b>49</b>
<b>8.</b>	<b><u>APPENDIX REPORT</u></b>	<b>49</b>

# **1. TEST STANDARDS AND REPORT VERSION**

## **1.1. Applicable Standards**

The tests were performed according to following standards:

[FCC Rules Part 2](#): FREQUENCY ALLOCATIONS AND RADIO TREATY MATTERS; GENERAL RULES AND REGULATIONS

[FCC Rules Part 22](#): PUBLIC MOBILE SERVICES

[FCC Rules Part 24](#): PERSONAL COMMUNICATIONS SERVICES

[FCC Rules Part 27](#): MISCELLANEOUS WIRELESS COMMUNICATIONS SERVICES

[ANSI C63.26: 2015](#): American National Standard for Compliance Testing of Transmitters Used in Licensed Radio Services

[KDB 971168 D01 Power Meas License Digital Systems v03](#): MEASUREMENT GUIDANCE FOR CERTIFICATION OF LICENSED DIGITAL TRANSMITTERS

## **1.2. Report version information**

Revision No.	Date of issue	Description
N/A	2020-02-26	Original

Listed Model(s):

50,50P,50S,50T,55,55HC,50F,iData 50P,iData 50S,iData 50T,iData 50 Pro,iData 50 Plus,iData 50F,iData 55,iData 55HC,iData 55HC Pro,iData 55HC Plus,iData 50 5G,Q5000,iData Q5000,iData Q5000 Plus,iData Q5000 Pro,iData 1500,iData 55,55HC,iData 1500-YH,QS-I50P,RF-RW316,SPD50,NBP-60,MT6550,NX2,A50BDT,SPD55,QCC S8,HYE 920,PT500,PT500UHF,XT-GZ1005,XT-GZ1008,KP 60P

## 2. Test Description

Test Item	Section in CFR 47	Result	Test Engineer
Conducted Output Power	Part 2.1046 Part 22.913(a) Part 24.232(c) Part 27.50	Pass	Jiongsheng Feng
Peak-to-Average Ratio	Part 24.232 Part 27.50	Pass	Jiongsheng Feng
99% Occupied Bandwidth & 26 dB Bandwidth	Part 2.1049 Part 22.917(b) Part 24.238(b) Part 27.53	Pass	Jiongsheng Feng
Band Edge	Part 2.1051 Part 22.917 Part 24.238 Part 27.53	Pass	Jiongsheng Feng
Conducted Spurious Emissions	Part 2.1051 Part 22.917 Part 24.238 Part 27.53	Pass	Jiongsheng Feng
Frequency stability VS Temperature	Part 2.1055(a)(1)(b) Part 22.355 Part 24.235 Part 27.54	Pass	Jiongsheng Feng
Frequency stability VS Voltage	Part 2.1055(d)(1)(2) Part 22.355 Part 24.235 Part 27.54	Pass	Jiongsheng Feng
ERP and EIRP	Part 22.913(a) Part 24.232(b) Part 27.50	Pass	Pan Xie
Radiated Spurious Emissions	Part 2.1053 Part 22.917 Part 24.238 Part 27.53	Pass	Pan Xie

Note: The measurement uncertainty is not included in the test result.

### 3. SUMMARY

#### 3.1. Client Information

Applicant:	WUXI IDATA TECHNOLOGY COMPANY LTD.
Address:	Floor 11,Building B1,Wuxi Binhu National Sensing Information Center,No.999 Gaolang East Road,Wuxi ,China
Manufacturer:	WUXI IDATA TECHNOLOGY COMPANY LTD.
Address:	Floor 11,Building B1,Wuxi Binhu National Sensing Information Center,No.999 Gaolang East Road,Wuxi ,China

#### 3.2. Product Description

Name of EUT:	New Mobile Computer		
Trade Mark:	iData		
Model No.:	iData 50		
Listed Model(s):	See page 3 of the report		
SIM Information:	Support One SIM Card		
Power supply:	DC 3.8V		
Adapter information 1:	Model:FJ-SW1260502000UN Input:100-240Va.c., 50/60Hz, 0.4A Max Output:5Vd.c., 2000mA		
Adapter information 2:	Model:FJ-SW1202000N Input:100-240Va.c., 50/60Hz, 0.6A Max Output:12Vd.c., 2000mA		
Hardware version:	M102		
Software version:	A5P_V400R001C01B016_EN06		
<b>4G</b>			
Operation Band:	<input checked="" type="checkbox"/> FDD Band 2	<input checked="" type="checkbox"/> FDD Band 4	<input checked="" type="checkbox"/> FDD Band 5
	<input checked="" type="checkbox"/> FDD Band 7	<input checked="" type="checkbox"/> FDD Band 12	<input checked="" type="checkbox"/> FDD Band 17
	<input checked="" type="checkbox"/> TDD Band 41		
Transmit frequency:	FDD Band 2:	1850.7 MHz – 1909.3 MHz	
	FDD Band 4:	1710.7 MHz – 1754.3 MHz	
	FDD Band 5:	824.7 MHz – 848.3 MHz	
	FDD Band 7:	2502.5 MHz – 2567.5 MHz	
	FDD Band 12:	699.7 MHz – 715.3 MHz	
	FDD Band 17:	706.5 MHz – 713.5 MHz	
	TDD Band 41:	2555 MHz – 2655 MHz	
Receive frequency:	FDD Band 2:	1930.7 MHz – 1989.3 MHz	
	FDD Band 4:	2110.7 MHz – 2154.3 MHz	
	FDD Band 5:	869.7 MHz – 893.3 MHz	
	FDD Band 7:	2622.5 MHz – 2687.5 MHz	
	FDD Band 12:	729.7 MHz – 745.3 MHz	

	FDD Band 17: 736.5 MHz – 743.5 MHz TDD Band 41: 2555 MHz – 2655 MHz
Channel bandwidth:	FDD Band 2: 1.4MHz, 3MHz, 5MHz, 10MHz, 15MHz, 20MHz FDD Band 4: 1.4MHz, 3MHz, 5MHz, 10MHz, 15MHz, 20MHz FDD Band 5: 1.4MHz, 3MHz, 5MHz, 10MHz FDD Band 7: 5MHz, 10MHz, 15MHz, 20MHz FDD Band 12: 1.4MHz, 3MHz, 5MHz, 10MHz FDD Band 17: 5MHz, 10MHz TDD Band 41: 5MHz, 10MHz, 15MHz, 20MHz
Power Class:	Class 3
Modulation type:	QPSK, 16QAM
Antenna type	PIFA Antenna
Antenna Gain	Band2: 0dBi Band4: 0.9dBi Band5: -1dBi Band7: 0dBi Band12: 0dBi Band17: 0dBi Band41: 0dBi

### 3.3. Operation state

➤ **Test frequency list**

<p>FDD Band 2</p>	<table border="1"> <thead> <tr> <th>Test Frequency ID</th> <th>Bandwidth [MHz]</th> <th>N<sub>UL</sub></th> <th>Frequency of Uplink [MHz]</th> <th>N<sub>DL</sub></th> <th>Frequency of Downlink [MHz]</th> </tr> </thead> <tbody> <tr> <td rowspan="5">Low Range</td> <td>1.4</td> <td>18607</td> <td>1850.7</td> <td>607</td> <td>1930.7</td> </tr> <tr> <td>3</td> <td>18615</td> <td>1851.5</td> <td>615</td> <td>1931.5</td> </tr> <tr> <td>5</td> <td>18625</td> <td>1852.5</td> <td>625</td> <td>1932.5</td> </tr> <tr> <td>10</td> <td>18650</td> <td>1855</td> <td>650</td> <td>1935</td> </tr> <tr> <td>15<sup>III</sup></td> <td>18675</td> <td>1857.5</td> <td>675</td> <td>1937.5</td> </tr> <tr> <td rowspan="2">Mid Range</td> <td>20<sup>III</sup></td> <td>18700</td> <td>1860</td> <td>700</td> <td>1940</td> </tr> <tr> <td>1.4/3/5/10/15<sup>III</sup>/20<sup>III</sup></td> <td>18900</td> <td>1880</td> <td>900</td> <td>1960</td> </tr> <tr> <td rowspan="6">High Range</td> <td>1.4</td> <td>19193</td> <td>1909.3</td> <td>1193</td> <td>1989.3</td> </tr> <tr> <td>3</td> <td>19195</td> <td>1908.5</td> <td>1185</td> <td>1988.5</td> </tr> <tr> <td>5</td> <td>19175</td> <td>1907.5</td> <td>1175</td> <td>1987.5</td> </tr> <tr> <td>10</td> <td>19150</td> <td>1905</td> <td>1150</td> <td>1985</td> </tr> <tr> <td>15<sup>III</sup></td> <td>19125</td> <td>1902.5</td> <td>1125</td> <td>1982.5</td> </tr> <tr> <td>20<sup>III</sup></td> <td>19100</td> <td>1900</td> <td>1100</td> <td>1980</td> </tr> </tbody> </table> <p>NOTE 1: Bandwidth for which a relaxation of the specified UE receiver sensitivity requirement (TS 36.101 [27] Clause 7.3) is allowed.</p>	Test Frequency ID	Bandwidth [MHz]	N <sub>UL</sub>	Frequency of Uplink [MHz]	N <sub>DL</sub>	Frequency of Downlink [MHz]	Low Range	1.4	18607	1850.7	607	1930.7	3	18615	1851.5	615	1931.5	5	18625	1852.5	625	1932.5	10	18650	1855	650	1935	15 <sup>III</sup>	18675	1857.5	675	1937.5	Mid Range	20 <sup>III</sup>	18700	1860	700	1940	1.4/3/5/10/15 <sup>III</sup> /20 <sup>III</sup>	18900	1880	900	1960	High Range	1.4	19193	1909.3	1193	1989.3	3	19195	1908.5	1185	1988.5	5	19175	1907.5	1175	1987.5	10	19150	1905	1150	1985	15 <sup>III</sup>	19125	1902.5	1125	1982.5	20 <sup>III</sup>	19100	1900	1100	1980
Test Frequency ID	Bandwidth [MHz]	N <sub>UL</sub>	Frequency of Uplink [MHz]	N <sub>DL</sub>	Frequency of Downlink [MHz]																																																																						
Low Range	1.4	18607	1850.7	607	1930.7																																																																						
	3	18615	1851.5	615	1931.5																																																																						
	5	18625	1852.5	625	1932.5																																																																						
	10	18650	1855	650	1935																																																																						
	15 <sup>III</sup>	18675	1857.5	675	1937.5																																																																						
Mid Range	20 <sup>III</sup>	18700	1860	700	1940																																																																						
	1.4/3/5/10/15 <sup>III</sup> /20 <sup>III</sup>	18900	1880	900	1960																																																																						
High Range	1.4	19193	1909.3	1193	1989.3																																																																						
	3	19195	1908.5	1185	1988.5																																																																						
	5	19175	1907.5	1175	1987.5																																																																						
	10	19150	1905	1150	1985																																																																						
	15 <sup>III</sup>	19125	1902.5	1125	1982.5																																																																						
	20 <sup>III</sup>	19100	1900	1100	1980																																																																						
<p>FDD Band 4</p>	<table border="1"> <thead> <tr> <th>Test Frequency ID</th> <th>Bandwidth [MHz]</th> <th>N<sub>UL</sub></th> <th>Frequency of Uplink [MHz]</th> <th>N<sub>DL</sub></th> <th>Frequency of Downlink [MHz]</th> </tr> </thead> <tbody> <tr> <td rowspan="5">Low Range</td> <td>1.4</td> <td>19957</td> <td>1710.7</td> <td>1957</td> <td>2110.7</td> </tr> <tr> <td>3</td> <td>19965</td> <td>1711.5</td> <td>1965</td> <td>2111.5</td> </tr> <tr> <td>5</td> <td>19975</td> <td>1712.5</td> <td>1975</td> <td>2112.5</td> </tr> <tr> <td>10</td> <td>20000</td> <td>1715</td> <td>2000</td> <td>2115</td> </tr> <tr> <td>15</td> <td>20025</td> <td>1717.5</td> <td>2025</td> <td>2117.5</td> </tr> <tr> <td rowspan="2">Mid Range</td> <td>20</td> <td>20050</td> <td>1720</td> <td>2050</td> <td>2120</td> </tr> <tr> <td>1.4/3/5/10/15/20</td> <td>20175</td> <td>1732.5</td> <td>2175</td> <td>2132.5</td> </tr> <tr> <td rowspan="6">High Range</td> <td>1.4</td> <td>20393</td> <td>1754.3</td> <td>2393</td> <td>2154.3</td> </tr> <tr> <td>3</td> <td>20385</td> <td>1753.5</td> <td>2385</td> <td>2153.5</td> </tr> <tr> <td>5</td> <td>20375</td> <td>1752.5</td> <td>2375</td> <td>2152.5</td> </tr> <tr> <td>10</td> <td>20350</td> <td>1750</td> <td>2350</td> <td>2150</td> </tr> <tr> <td>15</td> <td>20325</td> <td>1747.5</td> <td>2325</td> <td>2147.5</td> </tr> <tr> <td>20</td> <td>20300</td> <td>1745</td> <td>2300</td> <td>2145</td> </tr> </tbody> </table>	Test Frequency ID	Bandwidth [MHz]	N <sub>UL</sub>	Frequency of Uplink [MHz]	N <sub>DL</sub>	Frequency of Downlink [MHz]	Low Range	1.4	19957	1710.7	1957	2110.7	3	19965	1711.5	1965	2111.5	5	19975	1712.5	1975	2112.5	10	20000	1715	2000	2115	15	20025	1717.5	2025	2117.5	Mid Range	20	20050	1720	2050	2120	1.4/3/5/10/15/20	20175	1732.5	2175	2132.5	High Range	1.4	20393	1754.3	2393	2154.3	3	20385	1753.5	2385	2153.5	5	20375	1752.5	2375	2152.5	10	20350	1750	2350	2150	15	20325	1747.5	2325	2147.5	20	20300	1745	2300	2145
Test Frequency ID	Bandwidth [MHz]	N <sub>UL</sub>	Frequency of Uplink [MHz]	N <sub>DL</sub>	Frequency of Downlink [MHz]																																																																						
Low Range	1.4	19957	1710.7	1957	2110.7																																																																						
	3	19965	1711.5	1965	2111.5																																																																						
	5	19975	1712.5	1975	2112.5																																																																						
	10	20000	1715	2000	2115																																																																						
	15	20025	1717.5	2025	2117.5																																																																						
Mid Range	20	20050	1720	2050	2120																																																																						
	1.4/3/5/10/15/20	20175	1732.5	2175	2132.5																																																																						
High Range	1.4	20393	1754.3	2393	2154.3																																																																						
	3	20385	1753.5	2385	2153.5																																																																						
	5	20375	1752.5	2375	2152.5																																																																						
	10	20350	1750	2350	2150																																																																						
	15	20325	1747.5	2325	2147.5																																																																						
	20	20300	1745	2300	2145																																																																						
<p>FDD Band 5</p>	<table border="1"> <thead> <tr> <th>Test Frequency ID</th> <th>Bandwidth [MHz]</th> <th>N<sub>UL</sub></th> <th>Frequency of Uplink [MHz]</th> <th>N<sub>DL</sub></th> <th>Frequency of Downlink [MHz]</th> </tr> </thead> <tbody> <tr> <td rowspan="4">Low Range</td> <td>1.4</td> <td>20407</td> <td>824.7</td> <td>2407</td> <td>869.7</td> </tr> <tr> <td>3</td> <td>20416</td> <td>825.5</td> <td>2415</td> <td>870.5</td> </tr> <tr> <td>5</td> <td>20426</td> <td>826.5</td> <td>2425</td> <td>871.5</td> </tr> <tr> <td>10<sup>III</sup></td> <td>20450</td> <td>829</td> <td>2450</td> <td>874</td> </tr> <tr> <td>Mid Range</td> <td>1.4/3/5/10<sup>III</sup></td> <td>20625</td> <td>836.5</td> <td>2525</td> <td>881.5</td> </tr> <tr> <td rowspan="4">High Range</td> <td>1.4</td> <td>20643</td> <td>848.3</td> <td>2643</td> <td>893.3</td> </tr> <tr> <td>3</td> <td>20636</td> <td>847.5</td> <td>2635</td> <td>892.5</td> </tr> <tr> <td>5</td> <td>20626</td> <td>846.5</td> <td>2625</td> <td>891.5</td> </tr> <tr> <td>10<sup>III</sup></td> <td>20600</td> <td>844</td> <td>2600</td> <td>889</td> </tr> </tbody> </table> <p>NOTE 1: Bandwidth for which a relaxation of the specified UE receiver sensitivity requirement (TS 36.101 [27] Clause 7.3) is allowed.</p>	Test Frequency ID	Bandwidth [MHz]	N <sub>UL</sub>	Frequency of Uplink [MHz]	N <sub>DL</sub>	Frequency of Downlink [MHz]	Low Range	1.4	20407	824.7	2407	869.7	3	20416	825.5	2415	870.5	5	20426	826.5	2425	871.5	10 <sup>III</sup>	20450	829	2450	874	Mid Range	1.4/3/5/10 <sup>III</sup>	20625	836.5	2525	881.5	High Range	1.4	20643	848.3	2643	893.3	3	20636	847.5	2635	892.5	5	20626	846.5	2625	891.5	10 <sup>III</sup>	20600	844	2600	889																				
Test Frequency ID	Bandwidth [MHz]	N <sub>UL</sub>	Frequency of Uplink [MHz]	N <sub>DL</sub>	Frequency of Downlink [MHz]																																																																						
Low Range	1.4	20407	824.7	2407	869.7																																																																						
	3	20416	825.5	2415	870.5																																																																						
	5	20426	826.5	2425	871.5																																																																						
	10 <sup>III</sup>	20450	829	2450	874																																																																						
Mid Range	1.4/3/5/10 <sup>III</sup>	20625	836.5	2525	881.5																																																																						
High Range	1.4	20643	848.3	2643	893.3																																																																						
	3	20636	847.5	2635	892.5																																																																						
	5	20626	846.5	2625	891.5																																																																						
	10 <sup>III</sup>	20600	844	2600	889																																																																						
<p>FDD Band 7</p>	<table border="1"> <thead> <tr> <th>Test Frequency ID</th> <th>Bandwidth [MHz]</th> <th>N<sub>UL</sub></th> <th>Frequency of Uplink [MHz]</th> <th>N<sub>DL</sub></th> <th>Frequency of Downlink [MHz]</th> </tr> </thead> <tbody> <tr> <td rowspan="4">Low Range</td> <td>5</td> <td>20775</td> <td>2502.5</td> <td>2775</td> <td>2622.5</td> </tr> <tr> <td>10</td> <td>20800</td> <td>2505</td> <td>2800</td> <td>2625</td> </tr> <tr> <td>15</td> <td>20825</td> <td>2507.5</td> <td>2825</td> <td>2627.5</td> </tr> <tr> <td>20<sup>III</sup></td> <td>20850</td> <td>2510</td> <td>2850</td> <td>2630</td> </tr> <tr> <td>Mid Range</td> <td>5/10/15/20<sup>III</sup></td> <td>21100</td> <td>2535</td> <td>3100</td> <td>2655</td> </tr> <tr> <td rowspan="4">High Range</td> <td>5</td> <td>21425</td> <td>2567.5</td> <td>3425</td> <td>2687.5</td> </tr> <tr> <td>10</td> <td>21400</td> <td>2565</td> <td>3400</td> <td>2685</td> </tr> <tr> <td>15</td> <td>21375</td> <td>2562.5</td> <td>3375</td> <td>2682.5</td> </tr> <tr> <td>20<sup>III</sup></td> <td>21350</td> <td>2560</td> <td>3350</td> <td>2680</td> </tr> </tbody> </table> <p>NOTE 1: Bandwidth for which a relaxation of the specified UE receiver sensitivity requirement (TS 36.101 [27] Clause 7.3) is allowed.</p>	Test Frequency ID	Bandwidth [MHz]	N <sub>UL</sub>	Frequency of Uplink [MHz]	N <sub>DL</sub>	Frequency of Downlink [MHz]	Low Range	5	20775	2502.5	2775	2622.5	10	20800	2505	2800	2625	15	20825	2507.5	2825	2627.5	20 <sup>III</sup>	20850	2510	2850	2630	Mid Range	5/10/15/20 <sup>III</sup>	21100	2535	3100	2655	High Range	5	21425	2567.5	3425	2687.5	10	21400	2565	3400	2685	15	21375	2562.5	3375	2682.5	20 <sup>III</sup>	21350	2560	3350	2680																				
Test Frequency ID	Bandwidth [MHz]	N <sub>UL</sub>	Frequency of Uplink [MHz]	N <sub>DL</sub>	Frequency of Downlink [MHz]																																																																						
Low Range	5	20775	2502.5	2775	2622.5																																																																						
	10	20800	2505	2800	2625																																																																						
	15	20825	2507.5	2825	2627.5																																																																						
	20 <sup>III</sup>	20850	2510	2850	2630																																																																						
Mid Range	5/10/15/20 <sup>III</sup>	21100	2535	3100	2655																																																																						
High Range	5	21425	2567.5	3425	2687.5																																																																						
	10	21400	2565	3400	2685																																																																						
	15	21375	2562.5	3375	2682.5																																																																						
	20 <sup>III</sup>	21350	2560	3350	2680																																																																						
<p>FDD Band 12</p>	<p><b>Table 4.3.1.1.12-1: Test frequencies for E-UTRA channel bandwidth for operating band 12</b></p> <table border="1"> <thead> <tr> <th>Test Frequency ID</th> <th>Bandwidth [MHz]</th> <th>N<sub>UL</sub></th> <th>Frequency of Uplink [MHz]</th> <th>N<sub>DL</sub></th> <th>Frequency of Downlink [MHz]</th> </tr> </thead> <tbody> <tr> <td rowspan="4">Low Range</td> <td>1.4</td> <td>23017</td> <td>699.7</td> <td>5017</td> <td>729.7</td> </tr> <tr> <td>3</td> <td>23025</td> <td>700.5</td> <td>5025</td> <td>730.5</td> </tr> <tr> <td>5<sup>III</sup></td> <td>23035</td> <td>701.5</td> <td>5035</td> <td>731.5</td> </tr> <tr> <td>10<sup>III</sup></td> <td>23050</td> <td>704</td> <td>5060</td> <td>734</td> </tr> <tr> <td>Mid Range</td> <td>1.4/3/5<sup>III</sup>/10<sup>III</sup></td> <td>23095</td> <td>707.5</td> <td>5095</td> <td>737.5</td> </tr> <tr> <td rowspan="4">High Range</td> <td>1.4</td> <td>23173</td> <td>715.3</td> <td>5173</td> <td>745.3</td> </tr> <tr> <td>3</td> <td>23165</td> <td>714.5</td> <td>5165</td> <td>744.5</td> </tr> <tr> <td>5<sup>III</sup></td> <td>23155</td> <td>713.5</td> <td>5155</td> <td>743.5</td> </tr> <tr> <td>10<sup>III</sup></td> <td>23130</td> <td>711</td> <td>5130</td> <td>741</td> </tr> </tbody> </table> <p>NOTE 1: Bandwidth for which a relaxation of the specified UE receiver sensitivity requirement (TS 36.101 [27] Clause 7.3) is allowed.</p>	Test Frequency ID	Bandwidth [MHz]	N <sub>UL</sub>	Frequency of Uplink [MHz]	N <sub>DL</sub>	Frequency of Downlink [MHz]	Low Range	1.4	23017	699.7	5017	729.7	3	23025	700.5	5025	730.5	5 <sup>III</sup>	23035	701.5	5035	731.5	10 <sup>III</sup>	23050	704	5060	734	Mid Range	1.4/3/5 <sup>III</sup> /10 <sup>III</sup>	23095	707.5	5095	737.5	High Range	1.4	23173	715.3	5173	745.3	3	23165	714.5	5165	744.5	5 <sup>III</sup>	23155	713.5	5155	743.5	10 <sup>III</sup>	23130	711	5130	741																				
Test Frequency ID	Bandwidth [MHz]	N <sub>UL</sub>	Frequency of Uplink [MHz]	N <sub>DL</sub>	Frequency of Downlink [MHz]																																																																						
Low Range	1.4	23017	699.7	5017	729.7																																																																						
	3	23025	700.5	5025	730.5																																																																						
	5 <sup>III</sup>	23035	701.5	5035	731.5																																																																						
	10 <sup>III</sup>	23050	704	5060	734																																																																						
Mid Range	1.4/3/5 <sup>III</sup> /10 <sup>III</sup>	23095	707.5	5095	737.5																																																																						
High Range	1.4	23173	715.3	5173	745.3																																																																						
	3	23165	714.5	5165	744.5																																																																						
	5 <sup>III</sup>	23155	713.5	5155	743.5																																																																						
	10 <sup>III</sup>	23130	711	5130	741																																																																						

<p>FDD Band 17</p>	<table border="1"> <thead> <tr> <th>Test Frequency ID</th> <th>Bandwidth [MHz]</th> <th>N<sub>UL</sub></th> <th>Frequency of Uplink [MHz]</th> <th>N<sub>DL</sub></th> <th>Frequency of Downlink [MHz]</th> </tr> </thead> <tbody> <tr> <td rowspan="2">Low Range</td> <td>5<sup>1M</sup></td> <td>23755</td> <td>706.5</td> <td>5755</td> <td>736.5</td> </tr> <tr> <td>10<sup>1M</sup></td> <td>23780</td> <td>709</td> <td>5780</td> <td>739</td> </tr> <tr> <td>Mid Range</td> <td>5<sup>1M</sup>/10<sup>1M</sup></td> <td>23790</td> <td>710</td> <td>5790</td> <td>740</td> </tr> <tr> <td rowspan="2">High Range</td> <td>5<sup>1M</sup></td> <td>23825</td> <td>713.5</td> <td>5825</td> <td>743.5</td> </tr> <tr> <td>10<sup>1M</sup></td> <td>23800</td> <td>711</td> <td>5800</td> <td>741</td> </tr> </tbody> </table> <p>NOTE 1: Bandwidth for which a relaxation of the specified UE receiver sensitivity requirement (TS 36.101 [27] Clause 7.3) is allowed.</p>	Test Frequency ID	Bandwidth [MHz]	N <sub>UL</sub>	Frequency of Uplink [MHz]	N <sub>DL</sub>	Frequency of Downlink [MHz]	Low Range	5 <sup>1M</sup>	23755	706.5	5755	736.5	10 <sup>1M</sup>	23780	709	5780	739	Mid Range	5 <sup>1M</sup> /10 <sup>1M</sup>	23790	710	5790	740	High Range	5 <sup>1M</sup>	23825	713.5	5825	743.5	10 <sup>1M</sup>	23800	711	5800	741
Test Frequency ID	Bandwidth [MHz]	N <sub>UL</sub>	Frequency of Uplink [MHz]	N <sub>DL</sub>	Frequency of Downlink [MHz]																														
Low Range	5 <sup>1M</sup>	23755	706.5	5755	736.5																														
	10 <sup>1M</sup>	23780	709	5780	739																														
Mid Range	5 <sup>1M</sup> /10 <sup>1M</sup>	23790	710	5790	740																														
High Range	5 <sup>1M</sup>	23825	713.5	5825	743.5																														
	10 <sup>1M</sup>	23800	711	5800	741																														
<p>TDD Band 41</p>	<table border="1"> <thead> <tr> <th>Test Frequency ID</th> <th>Bandwidth [MHz]</th> <th>EARFCN</th> <th>Frequency (UL and DL) [MHz]</th> </tr> </thead> <tbody> <tr> <td rowspan="4">Low Range</td> <td>5</td> <td>39675</td> <td>2498.5</td> </tr> <tr> <td>10</td> <td>39700</td> <td>2501</td> </tr> <tr> <td>15</td> <td>39725</td> <td>2503.5</td> </tr> <tr> <td>20</td> <td>39750</td> <td>2506</td> </tr> <tr> <td>Mid Range</td> <td>5/10/15/20</td> <td>40620</td> <td>2593</td> </tr> <tr> <td rowspan="4">High Range</td> <td>5</td> <td>41565</td> <td>2687.5</td> </tr> <tr> <td>10</td> <td>41540</td> <td>2685</td> </tr> <tr> <td>15</td> <td>41515</td> <td>2682.5</td> </tr> <tr> <td>20</td> <td>41490</td> <td>2680</td> </tr> </tbody> </table>	Test Frequency ID	Bandwidth [MHz]	EARFCN	Frequency (UL and DL) [MHz]	Low Range	5	39675	2498.5	10	39700	2501	15	39725	2503.5	20	39750	2506	Mid Range	5/10/15/20	40620	2593	High Range	5	41565	2687.5	10	41540	2685	15	41515	2682.5	20	41490	2680
Test Frequency ID	Bandwidth [MHz]	EARFCN	Frequency (UL and DL) [MHz]																																
Low Range	5	39675	2498.5																																
	10	39700	2501																																
	15	39725	2503.5																																
	20	39750	2506																																
Mid Range	5/10/15/20	40620	2593																																
High Range	5	41565	2687.5																																
	10	41540	2685																																
	15	41515	2682.5																																
	20	41490	2680																																



### 3.4. EUT operation mode

For RF test items

The EUT has been tested under typical operating condition. Testing was performed by configuring EUT to maximum output power status.

Test Items	Band	Bandwidth (MHz)						Modulation		RB #		
		1.4	3	5	10	15	20	QPSK	16QAM	1	Half	Full
Conducted Output Power	2	o	o	o	o	o	o	o	o	o	o	o
	4	o	o	o	o	o	o	o	o	o	o	o
	5	o	o	o	o	-	-	o	o	o	o	o
	7	-	-	o	o	o	o	o	o	o	o	o
	12	o	o	o	o	-	-	o	o	o	o	o
	17	-	-	o	o	-	-	o	o	o	o	o
	41	-	-	o	o	o	o	o	o	o	o	o
Peak-to-Average Ratio	2	o	o	o	o	o	o	o	o	o	-	o
	4	o	o	o	o	o	o	o	o	o	-	o
	5	o	o	o	o	-	-	o	o	o	-	o
	7	-	-	o	o	o	o	o	o	o	-	o
	12	o	o	o	o	-	-	o	o	o	-	o
	17	-	-	o	o	-	-	o	o	o	-	o
	41	-	-	o	o	o	o	o	o	o	-	o
99% Occupied Bandwidth & 26 dB Bandwidth	2	o	o	o	o	o	o	o	o	-	-	o
	4	o	o	o	o	o	o	o	o	-	-	o
	5	o	o	o	o	-	-	o	o	-	-	o
	7	-	-	o	o	o	o	o	o	-	-	o
	12	o	o	o	o	-	-	o	o	o	-	o
	17	-	-	o	o	-	-	o	o	-	-	o
	41	-	-	o	o	o	o	o	o	-	-	o
Band Edge	2	o	o	o	o	o	o	o	o	o	-	o
	4	o	o	o	o	o	o	o	o	o	-	o
	5	o	o	o	o	-	-	o	o	o	-	o
	7	-	-	o	o	o	o	o	o	o	-	o
	12	o	o	o	o	-	-	o	o	o	-	o
	17	-	-	o	o	-	-	o	o	o	-	o
	41	-	-	o	o	o	o	o	o	o	-	o
Conducted Spurious Emission	2	o	o	o	o	o	o	o	o	o	-	-
	4	o	o	o	o	o	o	o	o	o	-	-
	5	o	o	o	o	-	-	o	o	o	-	-
	7	-	-	o	o	o	o	o	o	o	-	-
	12	o	o	o	o	-	-	o	o	o	-	-
	17	-	-	o	o	-	-	o	o	o	-	-
	41	-	-	o	o	o	o	o	o	o	-	-
Frequency Stability	2	o	o	o	o	o	o	o	o	-	-	o
	4	o	o	o	o	o	o	o	o	-	-	o
	5	o	o	o	o	-	-	o	o	-	-	o
	7	-	-	o	o	o	o	o	o	-	-	o
	12	o	o	o	o	-	-	o	o	-	-	o
	17	-	-	o	o	-	-	o	o	-	-	o
	41	-	-	o	o	o	o	o	o	-	-	o
ERP and EIRP	2	o	o	o	o	o	o	o	o	o	-	-
	4	o	o	o	o	o	o	o	o	o	-	-
	5	o	o	o	o	-	-	o	o	o	-	-
	7	-	-	o	o	o	o	o	o	o	-	-
	12	o	o	o	o	-	-	o	o	o	-	-
	17	-	-	o	o	-	-	o	o	o	-	-

	41	-	-	o	o	o	o	o	o	o	-	-
Radiated Spurious Emission	2	o	o	o	o	o	o	o	o	o	-	-
	4	o	o	o	o	o	o	o	o	o	-	-
	5	o	o	o	o	-	-	o	o	o	-	-
	7	-	-	o	o	o	o	o	o	o	-	-
	12	o	o	o	o	-	-	o	o	o	-	-
	17	-	-	o	o	-	-	o	o	o	-	-
	41	--	-	o	o	o	o	o	o	o	-	-
Remark	<ol style="list-style-type: none"> <li>The mark "o" means that this configuration is chosen for testing</li> <li>The mark "- " means that this bandwidth is not test.</li> <li>The device is investigated from 30MHz to 10 times of fundamental signal for radiated spurious emission test under different RB size/offset and modulations in exploratory test. Subsequently, only the worst case emissions are reported.</li> </ol>											

### 3.5. EUT configuration

The following peripheral devices and interface cables were connected during the measurement:

- - supplied by the manufacturer
- - supplied by the lab

○ /	Manufacturer:	/
	Model No.:	/
○ /	Manufacturer:	/
	Model No.:	/

### 3.6. Modifications

No modifications were implemented to meet testing criteria.

## **4. TEST ENVIRONMENT**

### **4.1. Address of the test laboratory**

Laboratory: Shenzhen Huatongwei International Inspection Co., Ltd.

Address: 1/F, Bldg 3, Hongfa Hi-tech Industrial Park, Genyu Road, Tianliao, Gongming, Shenzhen, China

### **4.2. Test Facility**

#### **CNAS-Lab Code: L1225**

Shenzhen Huatongwei International Inspection Co., Ltd. has been assessed and proved to be in compliance with CNAS-CL01 Accreditation Criteria for Testing and Calibration Laboratories (identical to ISO/IEC17025: 2005 General Requirements) for the Competence of Testing and Calibration Laboratories.

#### **A2LA-Lab Cert. No.: 3902.01**

Shenzhen Huatongwei International Inspection Co., Ltd. EMC Laboratory has been accredited by A2LA for technical competence in the field of electrical testing, and proved to be in compliance with ISO/IEC 17025: 2005 General Requirements for the Competence of Testing and Calibration Laboratories and any additional program requirements in the identified field of testing.

#### **FCC-Registration No.: 762235**

Shenzhen Huatongwei International Inspection Co., Ltd. EMC Laboratory has been registered and fully described in a report filed with the FCC (Federal Communications Commission). The acceptance letter from the FCC is maintained in our files.

#### **IC-Registration No.:5377A**

Two 3m Alternate Test Site of Shenzhen Huatongwei International Inspection Co., Ltd. has been registered by Certification and Engineering Bureau of Industry Canada for the performance of radiated measurements with Registration No.: 5377A.

#### **ACA**

Shenzhen Huatongwei International Inspection Co., Ltd. EMC Laboratory can also perform testing for the Australian C-Tick mark as a result of our A2LA accreditation.

### 4.3. Equipments Used during the Test

Used	Test Equipment	Manufacturer	Equipment No.	Model No.	Serial No.	Last Cal. Date (YY-MM-DD)	Next Cal. Date (YY-MM-DD)
●	Signal and spectrum Analyzer	R&S	HTWE0242	FSV40	100048	2019/10/26	2020/10/25
●	Spectrum Analyzer	Agilent	HTWE0286	N9020A	MY50510187	2019/10/26	2020/10/25
●	Radio communication tester	R&S	HTWE0287	CMW500	137688-Lv	2019/10/26	2020/10/25
●	Test software	Tonscend	N/A	JS1120	N/A	N/A	N/A

#### ● Radiated Spurious Emission

Used	Test Equipment	Manufacturer	Equipment No.	Model No.	Serial No.	Last Cal. Date (YY-MM-DD)	Next Cal. Date (YY-MM-DD)
●	Semi-Anechoic Chamber	Albatross projects	HTWE0122	SAC-3m-01	N/A	2018/09/27	2021/09/26
●	Spectrum Analyzer	R&S	HTWE0098	FSP40	100597	2019/10/26	2020/10/25
●	Loop Antenna	R&S	HTWE0170	HFH2-Z2	100020	2018/04/02	2021/04/01
●	Broadband Horn Antenna	SCHWARZBECK	HTWE0103	BBHA9170	BBHA9170472	2018/10/11	2021/10/11
●	Ultra-Broadband Antenna	SCHWARZBECK	HTWE0123	VULB9163	538	2018/04/04	2021/04/03
●	Horn Antenna	SCHWARZBECK	HTWE0126	9120D	1011	2017/04/01	2020/03/31
●	Pre-amplifier	CD	HTWE0071	PAP-0102	12004	2019/11/14	2020/11/13
●	Broadband Preamplifier	SCHWARZBECK	HTWE0201	BBV 9718	9718-248	2019/05/23	2020/05/22
●	RF Connection Cable	HUBER+SUHNER	HTWE0120-01	6m 18GHz S Serisa	N/A	2019/05/10	2020/05/09
●	RF Connection Cable	HUBER+SUHNER	HTWE0120-02	6m 3GHz RG Serisa	N/A	2019/05/10	2020/05/09
●	RF Connection Cable	HUBER+SUHNER	HTWE0120-03	6m 3GHz RG Serisa	N/A	2019/05/10	2020/05/09
●	RF Connection Cable	HUBER+SUHNER	HTWE0120-04	6m 3GHz RG Serisa	N/A	2019/05/10	2020/05/09
●	RF Connection Cable	HUBER+SUHNER	HTWE0121-01	6m 18GHz S Serisa	N/A	2019/05/10	2020/05/09
●	EMI Test Software	Audix	N/A	E3	N/A	N/A	N/A

#### ● Auxiliary Equipment

Used	Test Equipment	Manufacturer	Equipment No.	Model No.	Serial No.	Last Cal. Date (YY-MM-DD)	Next Cal. Date (YY-MM-DD)
●	Climate chamber	ESPEC	HTWE0254	GPL-2	N/A	2019/10/23	2020/10/22
●	DC Power Supply	Gwinstek	HTWE0274	SPS-2415	GER835793	N/A	N/A

#### 4.4. Environmental conditions

During the measurement the environmental conditions were within the listed ranges:

Voltage	VN=Nominal Voltage	DC 3.80V
	VL=Lower Voltage	DC 3.60V
	VH=Higher Voltage	DC 4.35V
Temperature	TN=Normal Temperature	25 °C
	Extreme Temperature	From -30° to + 50° centigrade
Humidity	30~60 %	
Air Pressure	950-1050 hPa	

#### 4.5. Statement of the measurement uncertainty

The data and results referenced in this document are true and accurate. The reader is cautioned that there may be errors within the calibration limits of the equipment and facilities. The measurement uncertainty was calculated for all measurements listed in this test report acc. to TR-100028-01 "Electromagnetic compatibility and Radio spectrum Matters (ERM); Uncertainties in the measurement of mobile radio equipment characteristics; Part 1" and TR-100028-02 "Electromagnetic compatibility and Radio spectrum Matters (ERM); Uncertainties in the measurement of mobile radio equipment characteristics; Part 2" and is documented in the Shenzhen Huatongwei International Inspection Co., Ltd quality system acc. to DIN EN ISO/IEC 17025. Furthermore, component and process variability of devices similar to that tested may result in additional deviation. The manufacturer has the sole responsibility of continued compliance of the device.

Hereafter the best measurement capability for Shenzhen Huatongwei laboratory is reported:

Test Items	Measurement Uncertainty	Notes
Transmitter power conducted	0.51 dB	(1)
Transmitter power Radiated	2.66dB for <1GHz 3.44dB for >1GHz	(1)
Conducted spurious emissions 9kHz~40GHz	0.51 dB	(1)
Radiated spurious emissions	2.66dB for <1GHz 3.44dB for >1GHz	(1)
Occupied Bandwidth	15Hz for <1GHz 70Hz for >1GHz	(1)
Frequency error	15Hz for <1GHz 70Hz for >1GHz	(1)

(1) This uncertainty represents an expanded uncertainty expressed at approximately the 95% confidence level using a coverage factor of  $k=1.96$ .

## **5. TEST CONDITIONS AND RESULTS**

### **5.1. Conducted Output Power**

**LIMIT**

N/A

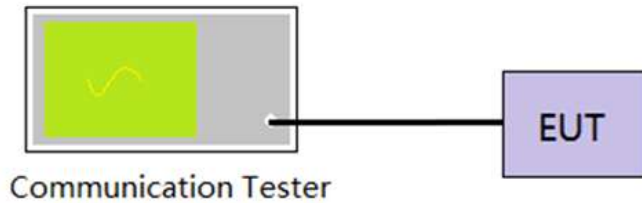
**TEST CONFIGURATION****TEST PROCEDURE**

1. The EUT output port was connected to communication tester.
2. Set EUT at maximum power through communication tester.
3. Select lowest, middle, and highest channels for each band and different modulation.
4. Measure the maximum burst average power.

**TEST MODE:**

Please refer to the clause 3.3

**TEST RESULTS** **Passed**       **Not Applicable**

Refer to appendix A on the section 8 appendix report

## 5.2. Peak-to-Average Ratio

### LIMIT

13dB

### TEST CONFIGURATION

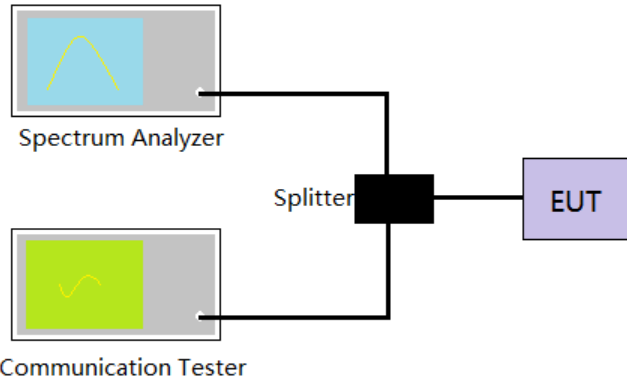

### TEST PROCEDURE

1. The EUT was connected to the spectrum analyzer and communication tester via a power splitter
2. Set EUT in maximum power output.
3. Center Frequency = Carrier frequency, RBW > Emission bandwidth of signal
4. The signal analyzer was set to collect one million samples to generate the CCDF curve
5. The measurement interval was set depending on the type of signal analyzed.
  - i. For continuous signals (>98% duty cycle), the measurement interval was set to 1ms.
  - ii. For burst transmissions, the spectrum analyzer is set to use an internal " RF Burst" trigger that issynced with an incoming pulse and the measurement interval is set to less than the durationof the " on time" of one burst to ensure that energy is only captured during a time in whichthetransmitter is operating at maximum power
6. Record the maximum PAPR level associated with a probability of 0.1%.

### TEST MODE:

Please refer to the clause 3.3

### TEST RESULTS

Passed       Not Applicable

Refer to appendix B on the section 8 appendix report

### 5.3. 99% Occupied Bandwidth & 26 dB Bandwidth

**LIMIT**

N/A

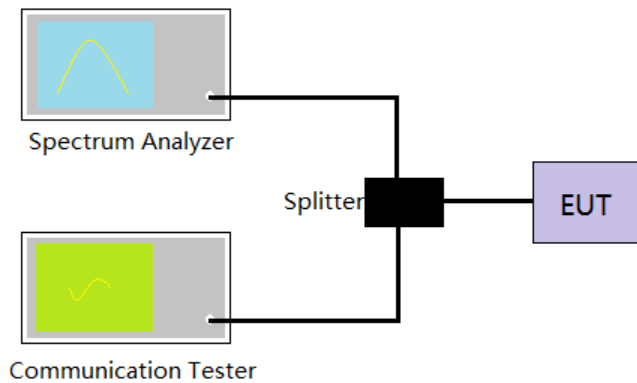
**TEST CONFIGURATION****TEST PROCEDURE**

1. The EUT was connected to the spectrum analyzer and communication tester via a power splitter
2. Set EUT in maximum power output.
3. Spectrum analyzer setting as follow:  
Center Frequency= Carrier frequency, RBW=1% to 5% of the anticipated OBW, VBW= 3 \* RBW,  
Detector=Peak,  
Trace maximum hold.
4. Record the value of 99% Occupied bandwidth and 26dB bandwidth.

**TEST MODE:**

Please refer to the clause 3.3

**TEST RESULTS** **Passed**       **Not Applicable**

Refer to appendix C on the section 8 appendix report



## 5.4. Band Edge

### LIMIT

Part 24.238 and Part 22.917 and Part 27.53 specify that the power of any emission outside of the authorized operating frequency ranges must be attenuated below the transmitting power (P) by a factor of at least  $43 + 10 \log(P)$  dB.

The specification that emissions shall be attenuated below the transmitter power (P) by at least  $43 + 10 \log(P)$  dB, translates in the relevant power range (1 to 0.001 W) to -13 dBm. At 1 W the specified minimum attenuation becomes 43 dB and relative to a 30 dBm (1 W) carrier becomes a limit of -13 dBm. At 0.001 W (0 dBm) the minimum attenuation is 13 dB, which again yields a limit of -13 dBm. In this way a translation of the specification from relative to absolute terms is carried out.

### LTE Band 7

Part 27.53 m(4) For mobile digital stations, the attenuation factor shall be not less than  $40 + 10 \log(P)$  dB on all frequencies between the channel edge and 5 megahertz from the channel edge,  $43 + 10 \log(P)$  dB on all frequencies between 5 megahertz and X megahertz from the channel edge, and  $55 + 10 \log(P)$  dB on all frequencies more than X megahertz from the channel edge, where X is the greater of 6 megahertz or the actual emission bandwidth as defined in paragraph (m)(6) of this section.

### TEST CONFIGURATION

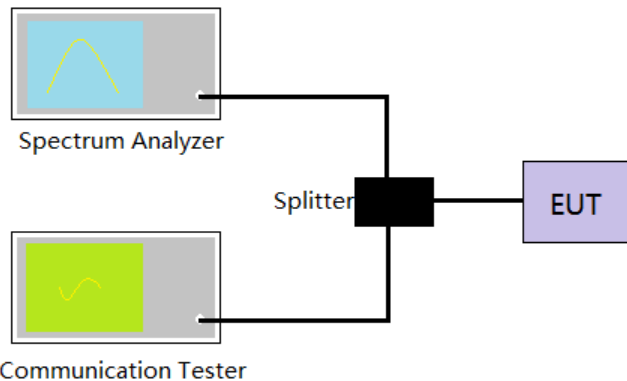

### TEST PROCEDURE

1. The EUT was connected to the spectrum analyzer and communication tester via a power splitter
2. Set EUT in maximum power output.
3. The band edges of low and high channels were measured.
4. Spectrum analyzer setting as follow:  
 RBW= no less than 1% of the OBW, VBW =3 \* RBW, Sweep time= Auto
5. Record the test plot.

### TEST MODE:

Please refer to the clause 3.3

### TEST RESULTS

Passed       Not Applicable

Refer to appendix D on the section 8 appendix report

## 5.5. Conducted Spurious Emissions

### LIMIT

Part 24.238 and Part 22.917 and Part 27.53 specify that the power of any emission outside of the authorized operating frequency ranges must be attenuated below the transmitting power (P) by a factor of at least  $43 + 10 \log(P)$  dB.

The specification that emissions shall be attenuated below the transmitter power (P) by at least  $43 + 10 \log(P)$  dB, translates in the relevant power range (1 to 0.001 W) to -13 dBm. At 1 W the specified minimum attenuation becomes 43 dB and relative to a 30 dBm (1 W) carrier becomes a limit of -13 dBm. At 0.001 W (0 dBm) the minimum attenuation is 13 dB, which again yields a limit of -13 dBm. In this way a translation of the specification from relative to absolute terms is carried out.

LTE Band 7

Part 27.53 m(4) For mobile digital stations, the attenuation factor shall be not less than  $40 + 10 \log(P)$  dB on all frequencies between the channel edge and 5 megahertz from the channel edge,  $43 + 10 \log(P)$  dB on all frequencies between 5 megahertz and X megahertz from the channel edge, and  $55 + 10 \log(P)$  dB on all frequencies more than X megahertz from the channel edge, where X is the greater of 6 megahertz or the actual emission bandwidth as defined in paragraph (m)(6) of this section. In addition, the attenuation factor shall not be less than  $43 + 10 \log(P)$  dB on all frequencies between 2490.5 MHz and 2496 MHz and  $55 + 10 \log(P)$  dB at or below 2490.5 MHz. Mobile Satellite Service licensees operating on frequencies below 2495 MHz may also submit a documented interference complaint against BRS licensees operating on channel BRS Channel 1 on the same terms and conditions as adjacent channel BRS or EBS licensees. Limit  $< -25$  dBm

### TEST CONFIGURATION

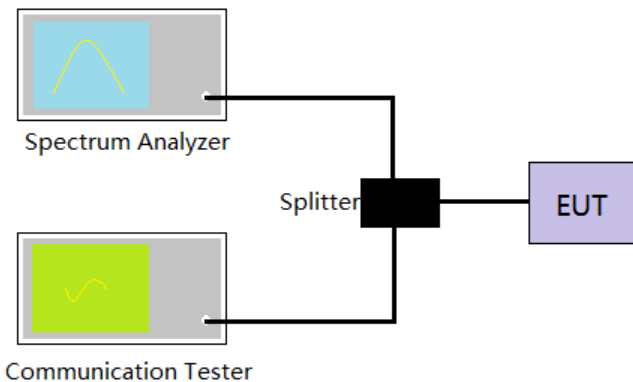

### TEST PROCEDURE

1. The EUT was connected to the spectrum analyzer and communication tester via a power splitter
2. Set EUT in maximum power output.
3. Spectrum analyzer setting as follow:
  - Below 1GHz, RBW=100KHz, VBW = 300KHz, Detector=Peak, Sweep time= Auto
  - Above 1GHz, RBW=1MHz, VBW=3MHz, Detector=Peak, Sweep time= Auto
  - Scan frequency range up to 10<sup>th</sup> harmonic.
4. Record the test plot.

### TEST MODE:

Please refer to the clause 3.3

### TEST RESULTS

**Passed**       **Not Applicable**

Refer to appendix E on the section 8 appendix report

## 5.6. Frequency stability VS Temperature measurement

### LIMIT

2.5ppm

### TEST CONFIGURATION

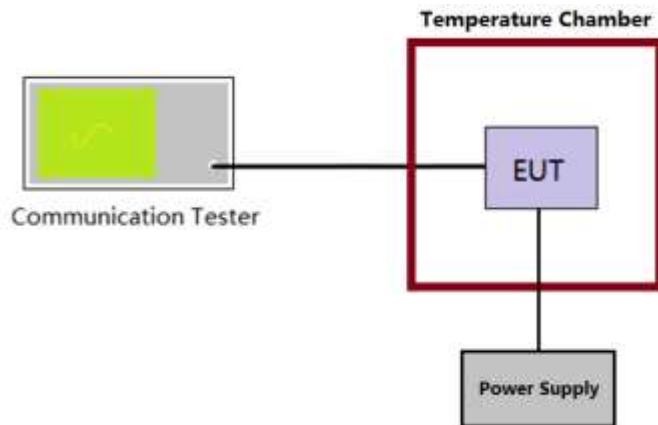

### TEST PROCEDURE

1. The equipment under test was connected to an external DC power supply and input rated voltage.
2. The EUT output port was connected to communication tester.
3. The EUT was placed inside the temperature chamber.
4. Turn EUT off and set the chamber temperature to  $-30^{\circ}\text{C}$ . After the temperature stabilized for approximately 30 minutes recorded the frequency.
5. Repeat step 4 measure with  $10^{\circ}\text{C}$  increased per stage until the highest temperature of  $+50^{\circ}\text{C}$  reached.

### TEST MODE:

Please refer to the clause 3.3

### TEST RESULTS

Passed       Not Applicable

Refer to appendix F on the section 8 appendix report

## 5.7. Frequency stability VS Voltage measurement

### LIMIT

2.5ppm

### TEST CONFIGURATION

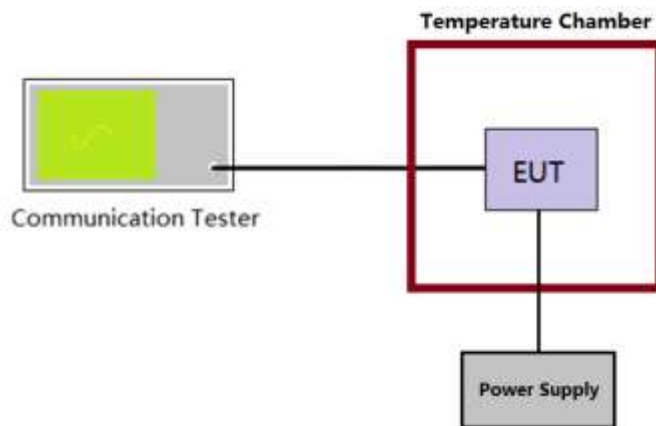

### TEST PROCEDURE

1. The equipment under test was connected to an external DC power supply and input rated voltage.
2. The EUT output port was connected to communication tester.
3. The EUT was placed inside the temperature chamber at 25°C
4. The power supply voltage to the EUT was varied  $\pm 15\%$  of the nominal value measured at the input to the EUT
5. Record the maximum frequency change.

### TEST MODE:

Please refer to the clause 3.3

### TEST RESULTS

Passed       Not Applicable

Refer to appendix F on the section 8 appendix report

## 5.8. ERP and EIRP

### LIMIT

LTE Band 2/7/41: 2W(33dBm) EIRP

LTE Band 4: 1W(30dBm) EIRP

LTE Band 5: 7W(38.50dBm) ERP

LTE Band 12/17: 3W(34.77dBm) ERP

### TEST CONFIGURATION

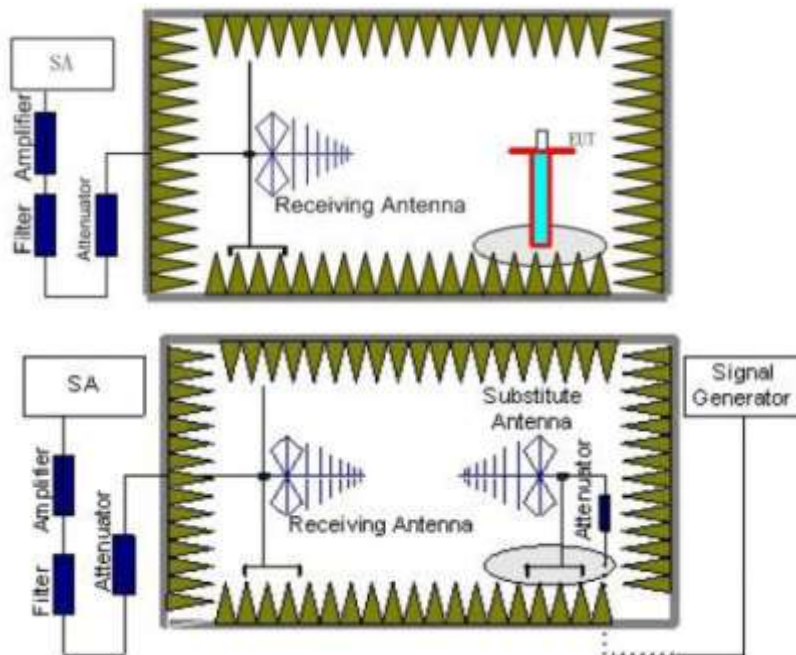

### TEST PROCEDURE

- Place the EUT in the center of the turntable.
  - For radiated emissions measurements performed at frequencies less than or equal to 1 GHz, the EUT shall be placed on a RF-transparent table at a nominal height of 80 cm above the reference ground plane
  - For radiated measurements performed at frequencies above 1 GHz, the EUT shall be placed on an RF transparent table at a nominal height of 1.5 m above the ground plane.
- Unless the EUT uses an integral antenna, the EUT shall be terminated with a non-radiating transmitter load. In cases where the EUT uses an adjustable antenna, the antenna shall be adjusted through typical positions and lengths to maximize emissions levels.
- The EUT shall be tested while operating on the frequency per manufacturer specification. Set the transmitter to operate in continuous transmit mode.
- Receiver or Spectrum set as follow:  
Below 1GHz, RBW=100kHz, VBW=300kHz, Detector=Peak, Sweep time=Auto  
Above 1GHz, RBW=1MHz, VBW=3MHz, Detector=Peck, Sweep time=Auto
- Each emission under consideration shall be evaluated:
  - Raise and lower the measurement antenna from 1 m to 4 m, as necessary to enable detection of the maximum emission amplitude relative to measurement antenna height.
  - Rotate the EUT through 360° to determine the maximum emission level relative to the axial position.
  - Return the turntable to the azimuth where the highest emission amplitude level was observed.

- d) Vary the measurement antenna height again through 1 m to 4 m again to find the height associated with the maximum emission amplitude.
  - e) Record the measured emission amplitude level and frequency
6. Repeat step 5 for each emission frequency with the measurement antenna oriented in both the horizontal and vertical polarizations to determine the orientation that gives the maximum emissions amplitude.
  7. Set-up the substitution measurement with the reference point of the substitution antenna located as near as possible to where the center of the EUT radiating element was located during the initial EUT measurement.
  8. Maintain the previous measurement instrument settings and test set-up, with the exception that the EUT is removed and replaced by the substitution antenna.
  9. Connect a signal generator to the substitution antenna; locate the signal generator so as to minimize any potential influences on the measurement results. Set the signal generator to the frequency where emissions are detected, and set an output power level such that the radiated signal can be detected by the measurement instrument, with sufficient dynamic range relative to the noise floor.
  10. For each emission that was detected and measured in the initial test
    - a) Vary the measurement antenna height between 1 m to 4 m to maximize the received (measured) signal amplitude.
    - b) Adjust the signal generator output power level until the amplitude detected by the measurement instrument equals the amplitude level of the emission previously measured directly in step 5 and step 6.
    - c) Record the output power level of the signal generator when equivalence is achieved in step b).
  11. Repeat step 8 through step 10 with the measurement antenna oriented in the opposite polarization.
  12. Calculate the emission power in dBm referenced to a half-wave dipole using the following equation:  
$$P_e = P_s(\text{dBm}) - \text{cable loss (dB)} + \text{antenna gain (dBd)}$$
where  
 $P_e$  = equivalent emission power in dBm  
 $P_s$  = source (signal generator) power in dBm  
*NOTE—dBd refers to the measured antenna gain in decibels relative to a half-wave dipole.*
  13. Correct the antenna gain of the substitution antenna if necessary to reference the emission power to a half-wave dipole. When using measurement antennas with the gain specified in dBi, the equivalent dipole-referenced gain can be determined from:  
$$\text{gain (dBd)} = \text{gain (dBi)} - 2.15 \text{ dB.}$$
If necessary, the antenna gain can be calculated from calibrated antenna factor information
  14. Provide the complete measurement results as a part of the test report.

**TEST MODE:**

Please refer to the clause 3.3

**TEST RESULTS**

Passed       Not Applicable

LTE Band 2-1.4MHz					
Modulation	Channel	EIRP (dBm)		Limit (dBm)	Result
		Vertical	Horizontal		
QPSK	Low	20.95	18.45	≤33.00	PASS
	Mid	21.18	18.38		
	High	20.91	18.43		
16QAM	Low	19.57	17.23		PASS
	Mid	19.85	17.30		
	High	19.51	17.43		

LTE Band 2-3MHz					
Modulation	Channel	EIRP (dBm)		Limit (dBm)	Result
		Vertical	Horizontal		
QPSK	Low	20.78	18.13	≤33.00	PASS
	Mid	21.07	18.37		
	High	20.73	18.30		
16QAM	Low	20.02	17.69		PASS
	Mid	20.10	17.54		
	High	19.53	17.53		

LTE Band 2-5MHz					
Modulation	Channel	EIRP (dBm)		Limit (dBm)	Result
		Vertical	Horizontal		
QPSK	Low	21.52	18.83	≤33.00	PASS
	Mid	21.74	18.70		
	High	21.59	18.78		
16QAM	Low	20.21	17.59		PASS
	Mid	20.39	17.63		
	High	20.02	17.73		

LTE Band 2-10MHz					
Modulation	Channel	EIRP (dBm)		Limit (dBm)	Result
		Vertical	Horizontal		
QPSK	Low	21.49	18.89	≤33.00	PASS
	Mid	21.71	18.76		
	High	21.55	18.91		
16QAM	Low	20.18	17.69		PASS
	Mid	20.36	17.77		
	High	19.99	17.83		

LTE Band 2-15MHz						
Modulation	Channel	EIRP (dBm)		Limit (dBm)	Result	
		Vertical	Horizontal			
QPSK	Low	21.25	18.52	≤33.00	PASS	
	Mid	21.53	18.70			
	High	21.29	18.72			
16QAM	Low	20.55	18.09		≤33.00	PASS
	Mid	20.55	17.95			
	High	19.95	17.87			

LTE Band 2-20MHz						
Modulation	Channel	EIRP (dBm)		Limit (dBm)	Result	
		Vertical	Horizontal			
QPSK	Low	21.38	18.63	≤33.00	PASS	
	Mid	21.73	18.85			
	High	21.49	18.85			
16QAM	Low	20.73	18.35		≤33.00	PASS
	Mid	20.71	18.08			
	High	20.10	17.94			



LTE Band 4-1.4MHz						
Modulation	Channel	EIRP (dBm)		Limit (dBm)	Result	
		Vertical	Horizontal			
QPSK	Low	22.12	20.35	≤30.00	PASS	
	Mid	22.53	20.71			
	High	22.55	20.40			
16QAM	Low	20.29	19.01		≤30.00	PASS
	Mid	20.66	19.40			
	High	20.57	19.20			

LTE Band 4-3MHz						
Modulation	Channel	EIRP (dBm)		Limit (dBm)	Result	
		Vertical	Horizontal			
QPSK	Low	22.46	20.35	≤30.00	PASS	
	Mid	22.46	20.51			
	High	22.29	20.27			
16QAM	Low	20.52	19.36		≤30.00	PASS
	Mid	20.83	18.98			
	High	20.82	19.36			

LTE Band 4-5MHz						
Modulation	Channel	EIRP (dBm)		Limit (dBm)	Result	
		Vertical	Horizontal			
QPSK	Low	22.95	20.78	≤30.00	PASS	
	Mid	23.21	21.13			
	High	23.20	20.85			
16QAM	Low	20.91	19.32		≤30.00	PASS
	Mid	21.21	20.13			
	High	21.02	19.44			

LTE Band 4-10MHz						
Modulation	Channel	EIRP (dBm)		Limit (dBm)	Result	
		Vertical	Horizontal			
QPSK	Low	22.59	20.65	≤30.00	PASS	
	Mid	22.92	20.99			
	High	22.92	20.68			
16QAM	Low	20.64	19.25		≤30.00	PASS
	Mid	20.97	19.61			
	High	20.83	19.38			

LTE Band 4-15MHz						
Modulation	Channel	EIRP (dBm)		Limit (dBm)	Result	
		Vertical	Horizontal			
QPSK	Low	22.96	20.61	≤30.00	PASS	
	Mid	22.87	20.76			
	High	22.68	20.54			
16QAM	Low	20.89	19.54		≤30.00	PASS
	Mid	21.16	19.42			
	High	21.09	19.50			

LTE Band 4-20MHz						
Modulation	Channel	EIRP (dBm)		Limit (dBm)	Result	
		Vertical	Horizontal			
QPSK	Low	23.01	20.66	≤30.00	PASS	
	Mid	23.06	20.84			
	High	22.84	20.58			
16QAM	Low	20.87	19.60		≤30.00	PASS
	Mid	21.34	19.37			
	High	21.29	19.63			

LTE Band 5-1.4MHz					
Modulation	Channel	ERP (dBm)		Limit (dBm)	Result
		Vertical	Horizontal		
QPSK	Low	22.05	20.71	≤38.50	PASS
	Mid	22.26	21.00		
	High	22.24	20.93		
16QAM	Low	20.77	19.43		PASS
	Mid	20.81	19.87		
	High	20.84	19.65		

LTE Band 5-3MHz					
Modulation	Channel	ERP (dBm)		Limit (dBm)	Result
		Vertical	Horizontal		
QPSK	Low	22.88	20.35	≤38.50	PASS
	Mid	22.64	20.62		
	High	22.18	20.39		
16QAM	Low	20.82	19.90		PASS
	Mid	20.90	19.70		
	High	20.93	19.50		

LTE Band 5-5MHz					
Modulation	Channel	ERP (dBm)		Limit (dBm)	Result
		Vertical	Horizontal		
QPSK	Low	22.56	20.55	≤38.50	PASS
	Mid	22.42	20.82		
	High	22.01	20.50		
16QAM	Low	21.19	19.91		PASS
	Mid	21.08	20.19		
	High	21.04	20.04		

LTE Band 5-10MHz					
Modulation	Channel	ERP (dBm)		Limit (dBm)	Result
		Vertical	Horizontal		
QPSK	Low	22.51	20.57	≤38.50	PASS
	Mid	22.37	20.84		
	High	21.98	20.51		
16QAM	Low	21.08	19.59		PASS
	Mid	21.16	20.05		
	High	21.22	19.85		

LTE Band 7-5MHz					
Modulation	Channel	EIRP (dBm)		Limit (dBm)	Result
		Vertical	Horizontal		
QPSK	Low	21.14	19.35	≤33.00	PASS
	Mid	21.29	19.32		
	High	21.15	19.01		
16QAM	Low	19.67	18.77		PASS
	Mid	19.83	18.71		
	High	19.72	18.69		

LTE Band 7-10MHz					
Modulation	Channel	EIRP (dBm)		Limit (dBm)	Result
		Vertical	Horizontal		
QPSK	Low	21.03	19.15	≤33.00	PASS
	Mid	21.11	18.99		
	High	20.99	18.97		
16QAM	Low	20.01	18.85		PASS
	Mid	20.00	18.62		
	High	19.92	18.52		

LTE Band 7-15MHz					
Modulation	Channel	EIRP (dBm)		Limit (dBm)	Result
		Vertical	Horizontal		
QPSK	Low	21.03	19.21	≤33.00	PASS
	Mid	21.17	19.32		
	High	21.03	19.20		
16QAM	Low	19.79	18.59		PASS
	Mid	19.92	18.50		
	High	19.81	18.50		

LTE Band 7-20MHz					
Modulation	Channel	EIRP (dBm)		Limit (dBm)	Result
		Vertical	Horizontal		
QPSK	Low	21.00	19.29	≤33.00	PASS
	Mid	21.08	19.12		
	High	20.95	19.11		
16QAM	Low	20.08	18.93		PASS
	Mid	20.29	19.00		
	High	20.11	18.95		

LTE Band 12-1.4MHz					
Modulation	Channel	ERP (dBm)		Limit (dBm)	Result
		Vertical	Horizontal		
QPSK	Low	21.80	19.89	≤34.77	PASS
	Mid	21.91	20.09		
	High	21.82	19.90		
16QAM	Low	20.60	19.29		PASS
	Mid	20.80	19.45		
	High	20.80	19.35		

LTE Band 12-3MHz					
Modulation	Channel	ERP (dBm)		Limit (dBm)	Result
		Vertical	Horizontal		
QPSK	Low	21.64	19.88	≤34.77	PASS
	Mid	21.83	20.11		
	High	21.58	19.82		
16QAM	Low	20.83	19.43		PASS
	Mid	20.80	19.58		
	High	20.80	19.40		

LTE Band 12-5MHz					
Modulation	Channel	ERP (dBm)		Limit (dBm)	Result
		Vertical	Horizontal		
QPSK	Low	21.31	19.70	≤34.77	PASS
	Mid	21.44	19.87		
	High	21.40	19.71		
16QAM	Low	20.96	19.53		PASS
	Mid	21.11	19.73		
	High	21.09	19.57		

LTE Band 12-10MHz					
Modulation	Channel	ERP (dBm)		Limit (dBm)	Result
		Vertical	Horizontal		
QPSK	Low	21.62	19.84	≤34.77	PASS
	Mid	21.80	20.02		
	High	21.56	19.78		
16QAM	Low	20.91	19.43		PASS
	Mid	21.24	19.65		
	High	21.22	19.53		

LTE Band 17-5MHz						
Modulation	Channel	ERP (dBm)		Limit (dBm)	Result	
		Vertical	Horizontal			
QPSK	Low	21.50	19.38	≤34.77	PASS	
	Mid	21.88	19.44			
	High	21.34	19.24			
16QAM	Low	19.91	18.20		≤34.77	PASS
	Mid	20.33	18.51			
	High	19.97	18.42			

LTE Band 17-10MHz						
Modulation	Channel	ERP (dBm)		Limit (dBm)	Result	
		Vertical	Horizontal			
QPSK	Low	21.46	19.03	≤34.77	PASS	
	Mid	21.84	19.30			
	High	21.31	19.11			
16QAM	Low	19.95	18.26		≤34.77	PASS
	Mid	20.36	18.55			
	High	20.00	18.44			

LTE Band 41-5MHz						
Modulation	Channel	EIRP (dBm)		Limit (dBm)	Result	
		Vertical	Horizontal			
QPSK	Low	21.22	19.40	≤33.00	PASS	
	Mid	21.38	19.38			
	High	21.24	19.03			
16QAM	Low	19.58	18.75		≤33.00	PASS
	Mid	19.75	18.69			
	High	19.64	18.68			

LTE Band 41-10MHz						
Modulation	Channel	EIRP (dBm)		Limit (dBm)	Result	
		Vertical	Horizontal			
QPSK	Low	21.10	19.17	≤33.00	PASS	
	Mid	21.18	19.00			
	High	21.06	18.99			
16QAM	Low	19.96	18.84		≤33.00	PASS
	Mid	19.94	18.60			
	High	19.87	18.49			

LTE Band 41-15MHz						
Modulation	Channel	EIRP (dBm)		Limit (dBm)	Result	
		Vertical	Horizontal			
QPSK	Low	21.10	19.24	≤33.00	PASS	
	Mid	21.25	19.37			
	High	21.11	19.24			
16QAM	Low	19.71	18.55		≤33.00	PASS
	Mid	19.86	18.46			
	High	19.75	18.46			

LTE Band 41-20MHz						
Modulation	Channel	EIRP (dBm)		Limit (dBm)	Result	
		Vertical	Horizontal			
QPSK	Low	21.07	19.33	≤33.00	PASS	
	Mid	21.15	19.15			
	High	21.03	19.15			
16QAM	Low	20.03	18.92		≤33.00	PASS
	Mid	20.26	19.01			
	High	20.07	18.97			

## 5.9. Radiated Spurious Emission

### LIMIT

LTE Band 2/4/5/12/13/17: -13dBm;

LTE Band 7: -25dBm

### TEST CONFIGURATION

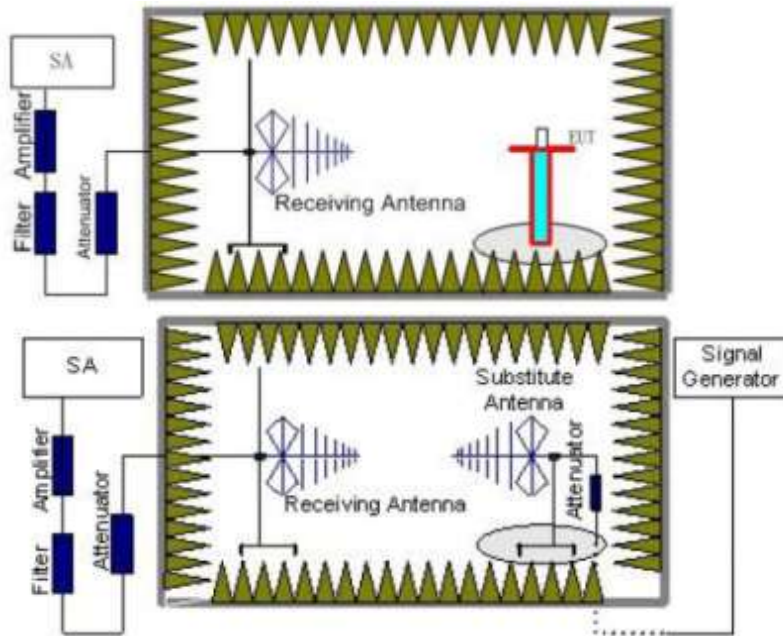

### TEST PROCEDURE

1. Place the EUT in the center of the turntable.
  - a) For radiated emissions measurements performed at frequencies less than or equal to 1 GHz, the EUT shall be placed on a RF-transparent table at a nominal height of 80 cm above the reference ground plane
  - b) For radiated measurements performed at frequencies above 1 GHz, the EUT shall be placed on an RF transparent table at a nominal height of 1.5 m above the ground plane.
2. Unless the EUT uses an integral antenna, the EUT shall be terminated with a non-radiating transmitter load. In cases where the EUT uses an adjustable antenna, the antenna shall be adjusted through typical positions and lengths to maximize emissions levels.
3. The EUT shall be tested while operating on the frequency per manufacturer specification. Set the transmitter to operate in continuous transmit mode.
4. Receiver or Spectrum set as follow:
  - Below 1GHz, RBW=100kHz, VBW=300kHz, Detector=Peak, Sweep time=Auto
  - Above 1GHz, RBW=1MHz, VBW=3MHz, Detector=Peck, Sweep time=Auto
5. Each emission under consideration shall be evaluated:
  - a) Raise and lower the measurement antenna from 1 m to 4 m, as necessary to enable detection of the maximum emission amplitude relative to measurement antenna height.
  - b) Rotate the EUT through 360° to determine the maximum emission level relative to the axial position.
  - c) Return the turntable to the azimuth where the highest emission amplitude level was observed.
  - d) Vary the measurement antenna height again through 1 m to 4 m again to find the height associated with the maximum emission amplitude.
  - e) Record the measured emission amplitude level and frequency



6. Repeat step 5 for each emission frequency with the measurement antenna oriented in both the horizontal and vertical polarizations to determine the orientation that gives the maximum emissions amplitude.
7. Set-up the substitution measurement with the reference point of the substitution antenna located as near as possible to where the center of the EUT radiating element was located during the initial EUT measurement.
8. Maintain the previous measurement instrument settings and test set-up, with the exception that the EUT is removed and replaced by the substitution antenna.
9. Connect a signal generator to the substitution antenna; locate the signal generator so as to minimize any potential influences on the measurement results. Set the signal generator to the frequency where emissions are detected, and set an output power level such that the radiated signal can be detected by the measurement instrument, with sufficient dynamic range relative to the noise floor.
10. For each emission that was detected and measured in the initial test
  - a) Vary the measurement antenna height between 1 m to 4 m to maximize the received (measured) signal amplitude.
  - b) Adjust the signal generator output power level until the amplitude detected by the measurement instrument equals the amplitude level of the emission previously measured directly in step 5 and step 6.
  - c) Record the output power level of the signal generator when equivalence is achieved in step b).
11. Repeat step 8 through step 10 with the measurement antenna oriented in the opposite polarization.
12. Calculate the emission power in dBm referenced to a half-wave dipole using the following equation:  
$$P_e = P_s(\text{dBm}) - \text{cable loss (dB)} + \text{antenna gain (dBd)}$$
where  
 $P_e$  = equivalent emission power in dBm  
 $P_s$  = source (signal generator) power in dBm  
*NOTE—dBd refers to the measured antenna gain in decibels relative to a half-wave dipole.*
13. Correct the antenna gain of the substitution antenna if necessary to reference the emission power to a half-wave dipole. When using measurement antennas with the gain specified in dBi, the equivalent dipole-referenced gain can be determined from:  
$$\text{gain (dBd)} = \text{gain (dBi)} - 2.15 \text{ dB.}$$
If necessary, the antenna gain can be calculated from calibrated antenna factor information
14. Provide the complete measurement results as a part of the test report.

**TEST MODE:**

Please refer to the clause 3.3

**TEST RESULTS**

**Passed**       **Not Applicable**

Note: only show the worse case for QPSK modulation.

LTE Band 2-1.4MHz					
Channel	Frequency (MHz)	Spurious Emission		Limit (dBm)	Result
		Polarization	Level (dBm)		
Low	3701.40	Vertical	-35.81	≤-13.00	Pass
	5552.10	V	-39.52		
	7402.80	V	-40.54		
	3701.40	Horizontal	-37.05	≤-13.00	Pass
	5552.10	H	-40.69		
	7402.80	H	-41.53		
Mid	3760.00	Vertical	-34.88	≤-13.00	Pass
	5640.00	V	-38.64		
	7520.00	V	-39.71		
	3760.00	Horizontal	-35.91	≤-13.00	Pass
	5640.00	H	-39.77		
	7520.00	H	-40.65		
High	3818.60	Vertical	-33.29	≤-13.00	Pass
	5727.90	V	-37.19		
	7637.20	V	-38.33		
	3818.60	Horizontal	-35.35	≤-13.00	Pass
	5727.90	H	-39.25		
	7637.20	H	-40.20		

LTE Band 2-3MHz					
Channel	Frequency (MHz)	Spurious Emission		Limit (dBm)	Result
		Polarization	Level (dBm)		
Low	3703.00	Vertical	-32.26	≤-13.00	Pass
	5554.50	V	-34.28		
	7406.00	V	-36.21		
	3703.00	Horizontal	-32.83	≤-13.00	Pass
	5554.50	H	-36.26		
	7406.00	H	-38.64		
Mid	3760.00	Vertical	-29.41	≤-13.00	Pass
	5640.00	V	-31.59		
	7520.00	V	-33.28		
	3760.00	Horizontal	-30.45	≤-13.00	Pass
	5640.00	H	-34.60		
	7520.00	H	-36.73		
High	3817.00	Vertical	-26.80	≤-13.00	Pass
	5725.50	V	-29.70		
	7634.00	V	-32.04		
	3817.00	Horizontal	-27.95	≤-13.00	Pass
	5725.50	H	-32.70		
	7634.00	H	-33.38		

LTE Band 2-5MHz					
Channel	Frequency (MHz)	Spurious Emission		Limit (dBm)	Result
		Polarization	Level (dBm)		
Low	3705.00	Vertical	-24.00	≤-13.00	Pass
	5557.50	V	-25.45		
	7410.00	V	-28.85		
	3705.00	Horizontal	-30.08	≤-13.00	Pass
	5557.50	H	-36.50		
	7410.00	H	-35.24		
Mid	3760.00	Vertical	-25.37	≤-13.00	Pass
	5640.00	V	-27.99		
	7520.00	V	-31.05		
	3760.00	Horizontal	-33.25	≤-13.00	Pass
	5640.00	H	-38.65		
	7520.00	H	-36.88		
High	3815.00	Vertical	-28.83	≤-13.00	Pass
	5722.50	V	-30.45		
	7630.00	V	-33.17		
	3815.00	Horizontal	-35.73	≤-13.00	Pass
	5722.50	H	-40.95		
	7630.00	H	-38.63		

LTE Band 2-10MHz					
Channel	Frequency (MHz)	Spurious Emission		Limit (dBm)	Result
		Polarization	Level (dBm)		
Low	3710.00	Vertical	-26.53	≤-13.00	Pass
	5565.00	V	-29.21		
	7420.00	V	-31.68		
	3710.00	Horizontal	-39.24	≤-13.00	Pass
	5565.00	H	-43.35		
	7420.00	H	-41.39		
Mid	3760.00	Vertical	-29.26	≤-13.00	Pass
	5640.00	V	-31.49		
	7520.00	V	-34.43		
	3760.00	Horizontal	-41.04	≤-13.00	Pass
	5640.00	H	-46.03		
	7520.00	H	-43.51		
High	3810.00	Vertical	-30.27	≤-13.00	Pass
	5715.00	V	-33.77		
	7620.00	V	-37.07		
	3810.00	Horizontal	-38.87	≤-13.00	Pass
	5715.00	H	-44.77		
	7620.00	H	-41.83		

LTE Band 2-15MHz					
Channel	Frequency (MHz)	Spurious Emission		Limit (dBm)	Result
		Polarization	Level (dBm)		
Low	3715.00	Vertical	-28.42	≤-13.00	Pass
	5572.50	V	-32.10		
	7430.00	V	-35.28		
	3715.00	Horizontal	-40.62	≤-13.00	Pass
	5572.50	H	-46.42		
	7430.00	H	-43.23		
Mid	3760.00	Vertical	-29.74	≤-13.00	Pass
	5640.00	V	-33.34		
	7520.00	V	-36.44		
	3760.00	Horizontal	-38.96	≤-13.00	Pass
	5640.00	H	-44.69		
	7520.00	H	-42.25		
High	3805.00	Vertical	-28.37	≤-13.00	Pass
	5707.50	V	-30.78		
	7610.00	V	-33.90		
	3805.00	Horizontal	-41.14	≤-13.00	Pass
	5707.50	H	-48.22		
	7610.00	H	-45.88		

LTE Band 2-20MHz					
Channel	Frequency (MHz)	Spurious Emission		Limit (dBm)	Result
		Polarization	Level (dBm)		
Low	3720.00	Vertical	-30.53	≤-13.00	Pass
	5580.00	V	-33.24		
	7440.00	V	-35.75		
	3720.00	Horizontal	-41.58	≤-13.00	Pass
	5580.00	H	-48.64		
	7440.00	H	-46.23		
Mid	3760.00	Vertical	-30.86	≤-13.00	Pass
	5640.00	V	-33.55		
	7520.00	V	-36.04		
	3760.00	Horizontal	-41.87	≤-13.00	Pass
	5640.00	H	-48.88		
	7520.00	H	-46.45		
High	3800.00	Vertical	-29.29	≤-13.00	Pass
	5700.00	V	-31.44		
	7600.00	V	-34.52		
	3800.00	Horizontal	-42.18	≤-13.00	Pass
	5700.00	H	-49.17		
	7600.00	H	-46.70		

## Remark:

1. Remark"---" means that the emission level is too low to be measured
2. The emission levels of below 1 GHz are very lower than the limit and not show in test report.

LTE Band 4-1.4MHz					
Channel	Frequency (MHz)	Spurious Emission		Limit (dBm)	Result
		Polarization	Level (dBm)		
Low	3421.40	Vertical	-32.83	≤-13.00	Pass
	5132.10	V	-38.50		
	6842.80	V	-38.43		
	3421.40	Horizontal	-34.48	≤-13.00	Pass
	5132.10	H	-40.06		
	6842.80	H	-39.75		
Mid	3465.00	Vertical	-31.59	≤-13.00	Pass
	5197.50	V	-37.33		
	6930.00	V	-37.33		
	3465.00	Horizontal	-32.96	≤-13.00	Pass
	5197.50	H	-38.83		
	6930.00	H	-38.58		
High	3508.60	Vertical	-29.47	≤-13.00	Pass
	5262.90	V	-35.40		
	7017.20	V	-35.50		
	3508.60	Horizontal	-31.22	≤-13.00	Pass
	5262.90	H	-37.18		
	7017.20	H	-37.01		

LTE Band 4-3MHz					
Channel	Frequency (MHz)	Spurious Emission		Limit (dBm)	Result
		Polarization	Level (dBm)		
Low	3423.00	Vertical	-32.13	≤-13.00	Pass
	5134.50	V	-37.77		
	6846.00	V	-37.85		
	3423.00	Horizontal	-33.33	≤-13.00	Pass
	5134.50	H	-40.52		
	6846.00	H	-39.55		
Mid	3465.00	Vertical	-34.91	≤-13.00	Pass
	5197.50	V	-40.54		
	6930.00	V	-39.99		
	3465.00	Horizontal	-38.65	≤-13.00	Pass
	5197.50	H	-44.27		
	6930.00	H	-43.91		
High	3507.00	Vertical	-36.78	≤-13.00	Pass
	5260.50	V	-42.24		
	7014.00	V	-41.60		
	3507.00	Horizontal	-41.23	≤-13.00	Pass
	5260.50	H	-47.17		
	7014.00	H	-46.03		

LTE Band 4-5MHz					
Channel	Frequency (MHz)	Spurious Emission		Limit (dBm)	Result
		Polarization	Level (dBm)		
Low	3425.00	Vertical	-40.19	≤-13.00	Pass
	5137.50	V	-44.74		
	6850.00	V	-44.99		
	3425.00	Horizontal	-42.59	≤-13.00	Pass
	5137.50	H	-48.45		
	6850.00	H	-47.12		
Mid	3465.00	Vertical	-41.21	≤-13.00	Pass
	5197.50	V	-45.70		
	6930.00	V	-45.89		
	3465.00	Horizontal	-43.79	≤-13.00	Pass
	5197.50	H	-49.42		
	6930.00	H	-48.04		
High	3505.00	Vertical	-42.68	≤-13.00	Pass
	5257.50	V	-47.04		
	7010.00	V	-47.16		
	3505.00	Horizontal	-44.75	≤-13.00	Pass
	5257.50	H	-50.32		
	7010.00	H	-48.81		

LTE Band 4-10MHz					
Channel	Frequency (MHz)	Spurious Emission		Limit (dBm)	Result
		Polarization	Level (dBm)		
Low	3430.00	Vertical	-45.29	≤-13.00	Pass
	5145.00	V	-48.63		
	6860.00	V	-48.13		
	3430.00	Horizontal	-45.01	≤-13.00	Pass
	5145.00	H	-50.56		
	6860.00	H	-49.02		
Mid	3465.00	Vertical	-45.48	≤-13.00	Pass
	5197.50	V	-48.81		
	6930.00	V	-48.66		
	3465.00	Horizontal	-45.22	≤-13.00	Pass
	5197.50	H	-50.73		
	6930.00	H	-49.18		
High	3500.00	Vertical	-45.74	≤-13.00	Pass
	5250.00	V	-49.05		
	7000.00	V	-48.89		
	3500.00	Horizontal	-45.42	≤-13.00	Pass
	5250.00	H	-50.92		
	7000.00	H	-49.34		

LTE Band 4-15MHz					
Channel	Frequency (MHz)	Spurious Emission		Limit (dBm)	Result
		Polarization	Level (dBm)		
Low	3435.00	Vertical	-46.43	≤-13.00	Pass
	5152.50	V	-49.75		
	6870.00	V	-49.44		
	3435.00	Horizontal	-47.50	≤-13.00	Pass
	5152.50	H	-52.87		
	6870.00	H	-52.95		
Mid	3465.00	Vertical	-49.83	≤-13.00	Pass
	5197.50	V	-52.94		
	6930.00	V	-52.44		
	3465.00	Horizontal	-50.14	≤-13.00	Pass
	5197.50	H	-55.01		
	6930.00	H	-54.98		
High	3495.00	Vertical	-52.33	≤-13.00	Pass
	5242.50	V	-55.21		
	6990.00	V	-54.60		
	3495.00	Horizontal	-52.36	≤-13.00	Pass
	5242.50	H	-57.10		
	6990.00	H	-58.84		

LTE Band 4-20MHz					
Channel	Frequency (MHz)	Spurious Emission		Limit (dBm)	Result
		Polarization	Level (dBm)		
Low	3440.00	Vertical	-64.59	≤-13.00	Pass
	5160.00	V	-58.00		
	6880.00	V	-56.97		
	3440.00	Horizontal	-54.73	≤-13.00	Pass
	5160.00	H	-67.32		
	6880.00	H	-69.10		
Mid	3465.00	Vertical	-75.59	≤-13.00	Pass
	5197.50	V	-63.24		
	6930.00	V	-61.90		
	3465.00	Horizontal	-61.69	≤-13.00	Pass
	5197.50	H	-74.44		
	6930.00	H	-72.93		
High	3490.00	Vertical	-78.72	≤-13.00	Pass
	5235.00	V	-65.25		
	6980.00	V	-63.73		
	3490.00	Horizontal	-63.43	≤-13.00	Pass
	5235.00	H	-76.09		
	6980.00	H	-74.50		

## Remark:

1. Remark"---" means that the emission level is too low to be measured
2. The emission levels of below 1 GHz are very lower than the limit and not show in test report.

LTE Band 5-1.4MHz					
Channel	Frequency (MHz)	Spurious Emission		Limit (dBm)	Result
		Polarization	Level (dBm)		
Low	1649.40	Vertical	-35.72	≤-13.00	Pass
	2474.10	V	-43.29		
	3298.80	V	-43.84		
	1649.40	Horizontal	-38.10	≤-13.00	Pass
	2474.10	H	-46.09		
	3298.80	H	-46.39		
Mid	1673.00	Vertical	-35.01	≤-13.00	Pass
	2509.50	V	-42.63		
	3346.00	V	-43.07		
	1673.00	Horizontal	-37.38	≤-13.00	Pass
	2509.50	H	-45.41		
	3346.00	H	-45.75		
High	1696.60	Vertical	-34.20	≤-13.00	Pass
	2544.90	V	-41.98		
	3393.20	V	-42.45		
	1696.60	Horizontal	-34.57	≤-13.00	Pass
	2544.90	H	-41.64		
	3393.20	H	-43.03		

LTE Band 5-3MHz					
Channel	Frequency (MHz)	Spurious Emission		Limit (dBm)	Result
		Polarization	Level (dBm)		
Low	1651.00	Vertical	-32.73	≤-13.00	Pass
	2476.50	V	-40.60		
	3302.00	V	-41.28		
	1651.00	Horizontal	-33.61	≤-13.00	Pass
	2476.50	H	-40.73		
	3302.00	H	-42.26		
Mid	1673.00	Vertical	-32.01	≤-13.00	Pass
	2509.50	V	-39.92		
	3346.00	V	-40.64		
	1673.00	Horizontal	-32.32	≤-13.00	Pass
	2509.50	H	-39.68		
	3346.00	H	-41.27		
High	1695.00	Vertical	-30.42	≤-13.00	Pass
	2542.50	V	-38.48		
	3390.00	V	-39.27		
	1695.00	Horizontal	-31.14	≤-13.00	Pass
	2542.50	H	-38.57		
	3390.00	H	-40.33		



LTE Band 5-5MHz					
Channel	Frequency (MHz)	Spurious Emission		Limit (dBm)	Result
		Polarization	Level (dBm)		
Low	1653.00	Vertical	-27.48	≤-13.00	Pass
	2479.50	V	-36.65		
	3306.00	V	-36.86		
	1653.00	Horizontal	-31.85	≤-13.00	Pass
	2479.50	H	-39.23		
	3306.00	H	-40.89		
Mid	1673.00	Vertical	-28.01	≤-13.00	Pass
	2509.50	V	-37.15		
	3346.00	V	-37.33		
	1673.00	Horizontal	-32.00	≤-13.00	Pass
	2509.50	H	-39.35		
	3346.00	H	-41.01		
High	1693.00	Vertical	-28.66	≤-13.00	Pass
	2539.50	V	-37.74		
	3386.00	V	-37.89		
	1693.00	Horizontal	-30.78	≤-13.00	Pass
	2539.50	H	-38.20		
	3386.00	H	-40.03		

LTE Band 5-10MHz					
Channel	Frequency (MHz)	Spurious Emission		Limit (dBm)	Result
		Polarization	Level (dBm)		
Low	1658.00	Vertical	-27.83	≤-13.00	Pass
	2487.00	V	-37.03		
	3316.00	V	-37.29		
	1658.00	Horizontal	-31.73	≤-13.00	Pass
	2487.00	H	-39.09		
	3316.00	H	-40.79		
Mid	1673.00	Vertical	-28.54	≤-13.00	Pass
	2509.50	V	-37.70		
	3346.00	V	-37.92		
	1673.00	Horizontal	-31.92	≤-13.00	Pass
	2509.50	H	-39.24		
	3346.00	H	-40.94		
High	1688.00	Vertical	-28.77	≤-13.00	Pass
	2532.00	V	-37.91		
	3376.00	V	-38.12		
	1688.00	Horizontal	-32.10	≤-13.00	Pass
	2532.00	H	-39.41		
	3376.00	H	-41.08		

## Remark:

1. Remark"---" means that the emission level is too low to be measured
2. The emission levels of below 1 GHz are very lower than the limit and not show in test report.

LTE Band 7-5MHz					
Channel	Frequency (MHz)	Spurious Emission		Limit (dBm)	Result
		Polarization	Level (dBm)		
Low	5005.00	Vertical	-36.61	≤-25.00	Pass
	7507.50	V	-41.04		
	10010.00	V	-41.44		
	5005.00	Horizontal	-39.10	≤-25.00	Pass
	7507.50	H	-44.10		
	10010.00	H	-43.24		
Mid	5070.00	Vertical	-35.35	≤-25.00	Pass
	7605.00	V	-39.18		
	10140.00	V	-39.88		
	5070.00	Horizontal	-35.67	≤-25.00	Pass
	7605.00	H	-41.19		
	10140.00	H	-41.29		
High	5135.00	Vertical	-31.81	≤-25.00	Pass
	7702.50	V	-35.96		
	10270.00	V	-36.82		
	5135.00	Horizontal	-33.31	≤-25.00	Pass
	7702.50	H	-38.98		
	10270.00	H	-39.41		

LTE Band 7-10MHz					
Channel	Frequency (MHz)	Spurious Emission		Limit (dBm)	Result
		Polarization	Level (dBm)		
Low	5010.00	Vertical	-30.21	≤-25.00	Pass
	7515.00	V	-34.60		
	10020.00	V	-35.66		
	5010.00	Horizontal	-34.64	≤-25.00	Pass
	7515.00	H	-40.23		
	10020.00	H	-40.47		
Mid	5070.00	Vertical	-31.21	≤-25.00	Pass
	7605.00	V	-35.54		
	10140.00	V	-36.54		
	5070.00	Horizontal	-36.25	≤-25.00	Pass
	7605.00	H	-41.53		
	10140.00	H	-41.71		
High	5130.00	Vertical	-32.85	≤-25.00	Pass
	7695.00	V	-37.03		
	10260.00	V	-37.96		
	5130.00	Horizontal	-37.31	≤-25.00	Pass
	7695.00	H	-42.53		
	10260.00	H	-42.56		

LTE Band 7-15MHz					
Channel	Frequency (MHz)	Spurious Emission		Limit (dBm)	Result
		Polarization	Level (dBm)		
Low	5015.00	Vertical	-31.41	≤-25.00	Pass
	7522.50	V	-35.80		
	10030.00	V	-36.92		
	5015.00	Horizontal	-39.54	≤-25.00	Pass
	7522.50	H	-45.77		
	10030.00	H	-45.73		
Mid	5070.00	Vertical	-34.45	≤-25.00	Pass
	7605.00	V	-38.48		
	10140.00	V	-38.88		
	5070.00	Horizontal	-38.27	≤-25.00	Pass
	7605.00	H	-44.74		
	10140.00	H	-44.75		
High	5125.00	Vertical	-32.89	≤-25.00	Pass
	7687.50	V	-37.06		
	10250.00	V	-37.53		
	5125.00	Horizontal	-37.23	≤-25.00	Pass
	7687.50	H	-43.76		
	10250.00	H	-43.92		

LTE Band 7-20MHz					
Channel	Frequency (MHz)	Spurious Emission		Limit (dBm)	Result
		Polarization	Level (dBm)		
Low	5020.00	Vertical	-31.35	≤-25.00	Pass
	7530.00	V	-35.14		
	10040.00	V	-35.90		
	5020.00	Horizontal	-35.75	≤-25.00	Pass
	7530.00	H	-42.37		
	10040.00	H	-42.74		
Mid	5070.00	Vertical	-30.24	≤-25.00	Pass
	7605.00	V	-34.10		
	10140.00	V	-34.92		
	5070.00	Horizontal	-33.82	≤-25.00	Pass
	7605.00	H	-40.81		
	10140.00	H	-41.25		
High	5120.00	Vertical	-28.87	≤-25.00	Pass
	7680.00	V	-32.86		
	10240.00	V	-33.74		
	5120.00	Horizontal	-35.89	≤-25.00	Pass
	7680.00	H	-42.75		
	10240.00	H	-42.90		

## Remark:

1. Remark"---" means that the emission level is too low to be measured
2. The emission levels of below 1 GHz are very lower than the limit and not show in test report.

LTE Band 12-1.4MHz					
Channel	Frequency (MHz)	Spurious Emission		Limit (dBm)	Result
		Polarization	Level (dBm)		
Low	1399.40	Vertical	-34.68	≤-13.00	Pass
	2099.10	V	-40.41		
	2798.80	V	-42.08		
	1399.40	Horizontal	-36.80	≤-13.00	Pass
	2099.10	H	-41.44		
	2798.80	H	-43.23		
Mid	1415.00	Vertical	-33.29	≤-13.00	Pass
	2122.50	V	-39.11		
	2830.00	V	-40.70		
	1415.00	Horizontal	-35.11	≤-13.00	Pass
	2122.50	H	-40.30		
	2830.00	H	-41.84		
High	1430.60	Vertical	-31.27	≤-13.00	Pass
	2145.90	V	-36.97		
	2861.20	V	-39.00		
	1430.60	Horizontal	-32.79	≤-13.00	Pass
	2145.90	H	-38.76		
	2861.20	H	-40.56		

LTE Band 12-3MHz					
Channel	Frequency (MHz)	Spurious Emission		Limit (dBm)	Result
		Polarization	Level (dBm)		
Low	1401.00	Vertical	-30.18	≤-13.00	Pass
	2101.50	V	-36.05		
	2802.00	V	-38.22		
	1401.00	Horizontal	-31.45	≤-13.00	Pass
	2101.50	H	-37.45		
	2802.00	H	-37.99		
Mid	1415.00	Vertical	-27.76	≤-13.00	Pass
	2122.50	V	-33.78		
	2830.00	V	-36.08		
	1415.00	Horizontal	-33.71	≤-13.00	Pass
	2122.50	H	-39.28		
	2830.00	H	-39.73		
High	1429.00	Vertical	-29.40	≤-13.00	Pass
	2143.50	V	-35.27		
	2858.00	V	-37.50		
	1429.00	Horizontal	-35.48	≤-13.00	Pass
	2143.50	H	-40.94		
	2858.00	H	-41.14		

LTE Band 12-5MHz					
Channel	Frequency (MHz)	Spurious Emission		Limit (dBm)	Result
		Polarization	Level (dBm)		
Low	1403.00	Vertical	-30.60	≤-13.00	Pass
	2104.50	V	-36.29		
	2806.00	V	-38.37		
	1403.00	Horizontal	-36.29	≤-13.00	Pass
	2104.50	H	-41.71		
	2806.00	H	-41.79		
Mid	1415.00	Vertical	-31.21	≤-13.00	Pass
	2122.50	V	-37.08		
	2830.00	V	-39.11		
	1415.00	Horizontal	-37.66	≤-13.00	Pass
	2122.50	H	-42.82		
	2830.00	H	-42.84		
High	1427.00	Vertical	-32.68	≤-13.00	Pass
	2140.50	V	-38.42		
	2854.00	V	-40.38		
	1427.00	Horizontal	-38.87	≤-13.00	Pass
	2140.50	H	-43.97		
	2854.00	H	-43.93		

LTE Band 12-10MHz					
Channel	Frequency (MHz)	Spurious Emission		Limit (dBm)	Result
		Polarization	Level (dBm)		
Low	1408.00	Vertical	-33.71	≤-13.00	Pass
	2112.00	V	-39.40		
	2816.00	V	-41.31		
	1408.00	Horizontal	-40.43	≤-13.00	Pass
	2112.00	H	-45.43		
	2816.00	H	-45.17		
Mid	1415.00	Vertical	-34.88	≤-13.00	Pass
	2122.50	V	-40.50		
	2830.00	V	-42.34		
	1415.00	Horizontal	-41.63	≤-13.00	Pass
	2122.50	H	-47.34		
	2830.00	H	-46.94		
High	1422.00	Vertical	-36.57	≤-13.00	Pass
	2133.00	V	-42.10		
	2844.00	V	-43.86		
	1422.00	Horizontal	-43.08	≤-13.00	Pass
	2133.00	H	-48.71		
	2844.00	H	-48.24		

## Remark:

1. Remark"---" means that the emission level is too low to be measured
2. The emission levels of below 1 GHz are very lower than the limit and not show in test report.

LTE Band 17-5MHz					
Channel	Frequency (MHz)	Spurious Emission		Limit (dBm)	Result
		Polarization	Level (dBm)		
Low	1413.00	Vertical	-37.59	≤-13.00	Pass
	2119.50	V	-40.09		
	2826.00	V	-40.98		
	1413.00	Horizontal	-40.17	≤-13.00	Pass
	2119.50	H	-42.52		
	2826.00	H	-43.04		
Mid	1420.00	Vertical	-35.65	≤-13.00	Pass
	2130.00	V	-38.27		
	2840.00	V	-39.27		
	1420.00	Horizontal	-37.77	≤-13.00	Pass
	2130.00	H	-39.97		
	2840.00	H	-40.62		
High	1427.00	Vertical	-31.25	≤-13.00	Pass
	2140.50	V	-34.26		
	2854.00	V	-35.46		
	1427.00	Horizontal	-34.84	≤-13.00	Pass
	2140.50	H	-37.22		
	2854.00	H	-37.18		

LTE Band 17-10MHz					
Channel	Frequency (MHz)	Spurious Emission		Limit (dBm)	Result
		Polarization	Level (dBm)		
Low	1418.00	Vertical	-28.32	≤-13.00	Pass
	2127.00	V	-31.77		
	2836.00	V	-33.35		
	1418.00	Horizontal	-32.13	≤-13.00	Pass
	2127.00	H	-34.68		
	2836.00	H	-35.02		
Mid	1420.00	Vertical	-26.29	≤-13.00	Pass
	2130.00	V	-29.86		
	2840.00	V	-31.55		
	1420.00	Horizontal	-29.83	≤-13.00	Pass
	2130.00	H	-32.82		
	2840.00	H	-33.25		
High	1422.00	Vertical	-24.08	≤-13.00	Pass
	2133.00	V	-27.85		
	2844.00	V	-29.64		
	1422.00	Horizontal	-27.69	≤-13.00	Pass
	2133.00	H	-30.81		
	2844.00	H	-31.54		

## Remark:

1. Remark"---" means that the emission level is too low to be measured
2. The emission levels of below 1 GHz are very lower than the limit and not show in test report

LTE Band 41-5MHz					
Channel	Frequency (MHz)	Spurious Emission		Limit (dBm)	Result
		Polarization	Level (dBm)		
Low	5115.00	Vertical	-36.63	≤-25.00	Pass
	7672.50	V	-41.07		
	10230.00	V	-41.47		
	5115.00	Horizontal	-39.07	≤-25.00	Pass
	7672.50	H	-44.07		
	10230.00	H	-43.23		
Mid	5210.00	Vertical	-35.39	≤-25.00	Pass
	7815.00	V	-39.25		
	10420.00	V	-39.94		
	5210.00	Horizontal	-35.71	≤-25.00	Pass
	7815.00	H	-41.22		
	10420.00	H	-41.32		
High	5305.00	Vertical	-31.92	≤-25.00	Pass
	7957.50	V	-36.10		
	10610.00	V	-36.94		
	5305.00	Horizontal	-33.40	≤-25.00	Pass
	7957.50	H	-39.05		
	10610.00	H	-39.48		

LTE Band 41-10MHz					
Channel	Frequency (MHz)	Spurious Emission		Limit (dBm)	Result
		Polarization	Level (dBm)		
Low	5120.00	Vertical	-30.35	≤-25.00	Pass
	7680.00	V	-34.77		
	10240.00	V	-35.81		
	5120.00	Horizontal	-34.70	≤-25.00	Pass
	7680.00	H	-40.28		
	10240.00	H	-40.52		
Mid	5210.00	Vertical	-31.33	≤-25.00	Pass
	7815.00	V	-35.69		
	10420.00	V	-36.68		
	5210.00	Horizontal	-36.28	≤-25.00	Pass
	7815.00	H	-41.56		
	10420.00	H	-41.73		
High	5290.00	Vertical	-32.93	≤-25.00	Pass
	7935.00	V	-37.15		
	10580.00	V	-38.07		
	5290.00	Horizontal	-37.32	≤-25.00	Pass
	7935.00	H	-42.54		
	10580.00	H	-42.56		

LTE Band 41-15MHz					
Channel	Frequency (MHz)	Spurious Emission		Limit (dBm)	Result
		Polarization	Level (dBm)		
Low	5125.00	Vertical	-32.93	≤-25.00	Pass
	7687.50	V	-37.15		
	10250.00	V	-38.07		
	5125.00	Horizontal	-37.32	≤-25.00	Pass
	7687.50	H	-42.54		
	10250.00	H	-42.56		
Mid	5210.00	Vertical	-32.93	≤-25.00	Pass
	7815.00	V	-37.15		
	10420.00	V	-38.07		
	5210.00	Horizontal	-37.32	≤-25.00	Pass
	7815.00	H	-42.54		
	10420.00	H	-42.56		
High	5295.00	Vertical	-32.93	≤-25.00	Pass
	7942.50	V	-37.15		
	10590.00	V	-38.07		
	5295.00	Horizontal	-37.32	≤-25.00	Pass
	7942.50	H	-42.54		
	10590.00	H	-42.56		

LTE Band 41-20MHz					
Channel	Frequency (MHz)	Spurious Emission		Limit (dBm)	Result
		Polarization	Level (dBm)		
Low	5130.00	Vertical	-32.93	≤-25.00	Pass
	7695.00	V	-37.15		
	10260.00	V	-38.07		
	5130.00	Horizontal	-37.32	≤-25.00	Pass
	7695.00	H	-42.54		
	10260.00	H	-42.56		
Mid	5210.00	Vertical	-32.93	≤-25.00	Pass
	7815.00	V	-37.15		
	10420.00	V	-38.07		
	5210.00	Horizontal	-37.32	≤-25.00	Pass
	7815.00	H	-42.54		
	10420.00	H	-42.56		
High	5290.00	Vertical	-32.93	≤-25.00	Pass
	7935.00	V	-37.15		
	10580.00	V	-38.07		
	5290.00	Horizontal	-37.32	≤-25.00	Pass
	7935.00	H	-42.54		
	10580.00	H	-42.56		

## Remark:

- Remark"---" means that the emission level is too low to be measured
- The emission levels of below 1 GHz are very lower than the limit and not show in test report.



## **6. TEST SETUP PHOTOS OF THE EUT**

Refere to the test report No.: CHTEW20020020

## **7. EXTERNAL AND INTERNAL PHOTOS OF THE EUT**

Refere to the test report No.: CHTEW20020020

## **8. APPENDIX REPORT**