



TEST REPORT

FCC TEST REPORT under FCC 15 Subpart B

Report Reference No.....: EA1410010F 01001

Engineer (name + signature).....: Kelly Wu

Approved by (name + signature).....: Joe Long

Date of issue.....: Oct. 15, 2014

Testing Laboratory.....: Dong Guan Anci Electronic Technology Co., Ltd

Address.....: No. A222, Building A, Shifu Hardware Plaza, Changan Town,
Dongguan City, Guangdong Pr., China.

Applicant's name.....: Luen Ming Electric Works CO., Ltd.

Address.....: Flat G, 2F. & 10F., Wah Hing Industrial Mansions, 36 Tai Yau
Street, San Po Kong, Kowloon, Hong Kong

Manufacturer.....: Shen Zhen Luen Ming Hing Plastic & Electric Technology
Co.,Ltd.

Address.....: No. 103, Ao Yi Road, Heng Gang, Long Gang Town, Shen Zhen
City, Guang Dong, China

Test specification:

Test item description.....: WIRELESS REMOTE BATTERY PACKS

Trade Mark.....: N/A

Model/Type reference.....: BP037202-VB320R

Ratings.....: Input rating: 4.2Vdc, 0.5-1.2A
Output rating: 4.2Vdc, 1.2A

Table of Contents

Page

1 GENERAL INFORMATION	3
1.1 CERTIFICATE	3
1.2 GENERAL PRODUCT INFORMATION	4
1.3. NORMATIVE REFERENCES	4
2. SUMMARY OF TEST RESULTS	5
2.1 MEASUREMENT UNCERTAINTY	5
2.2 DESCRIPTION OF TEST MODES	6
2.3 BLOCK DIGRAM SHOWING THE CONFIGURATION OF SYSTEM TESTED	6
2.4 DESCRIPTION OF SUPPORT UNITS	7
3. CONDUCTED EMISSION TEST	8
3.1 CONDUCTED EMISSION MEASUREMENT	8
3.1.1 LIMITS OF CONDUCTED EMISSION (MAINS PORT)	8
3.1.2 MEASUREMENT INSTRUMENTS LIST	8
3.1.4 DEVIATION FROM TEST STANDARD	9
3.1.5 TEST SETUP	9
3.1.6 EUT OPERATING CONDITIONS	9
3.1.7 TEST RESULTS	9
3.2 RADIATED EMISSION MEASUREMENT	10
3.2.1 LIMITS OF RADIATED EMISSION MEASUREMENT	10
3.2.2 MEASUREMENT INSTRUMENTS LIST	11
3.2.3 TEST PROCEDURE	11
3.2.4 DEVIATION FROM TEST STANDARD	11
3.2.5 TEST SETUP	12
3.2.6 EUT OPERATING CONDITIONS	12
3.2.7 TEST RESULTS	13



1 GENERAL INFORMATION

1.1 CERTIFICATE

Testing Laboratory : Dong Guan Anci Electronic Technology Co., Ltd.
 Address..... : No. A222, Building A, Shifu Hardware Plaza, Changan Town, Dongguan City, Guangdong Pr., China.

Applicant's name..... : Luen Ming Electric Works CO., Ltd.
 Address..... : Flat G, 2F. & 10F., Wah Hing Industrial Mansions, 36 Tai Yau Street, San Po Kong, Kowloon, Hong Kong
 Manufacturer..... : Shen Zhen Luen Ming Hing Plastic & Electric Technology Co.,Ltd.
 Address..... : No. 103, Ao Yi Road, Heng Gang, Long Gang Town, Shen Zhen City, Guang Dong, China
 Factory..... : Shen Zhen Luen Ming Hing Plastic & Electric Technology Co.,Ltd.
 Address..... : No. 103, Ao Yi Road, Heng Gang, Long Gang Town, Shen Zhen City, Guang Dong, China

Test specification:

Test item description : WIRELESS REMOTE BATTERY PACKS
 Trade Mark..... : N/A
 Model/Type reference : BP037202-VB320R
 Test Sample: BP037202-VB320R
 Ratings..... : Input rating: 4.2Vdc, 0.5-1.2A
 Output rating: 4.2Vdc, 1.2A
 Standards : 47 CFR FCC Part 15 Subpart B: 2013
 ANSI C63.4: 2009

The device described above was tested by Dong Guan Anci Electronic Technology Co., Ltd. to determine the maximum emission levels emanated from the device and severity levels of the device endure and its performance criterion. The measurement results are contained in this test report and Dong Guan Anci Electronic Technology Co., Ltd. assumes full responsibility for the accuracy and completeness of these measurements. This report shows the EUT is technically compliance with the above official standards.

This report applies to the above sample only and shall not be reproduced in part without written approval of Dong Guan Anci Electronic Technology Co., Ltd.



1.2 GENERAL PRODUCT INFORMATION

Product	WIRELESS REMTOTE BATTERY PACKS
Brand Name	N/A
Model No.	BP037202-VB320R
Working Voltage	DC 4.2V
Frequency Range	315 MHz
Channel Number	1
Channel Separation	N/A
Type of Modulation	FSK
Antenna Type	Spring Antenna
Equipment type	Superheterodyne Receiver

1.3. NORMATIVE REFERENCES

[1] **ANSI C63.4:2009** American National Standard for Methods of Measuring of Radio-Noise Emissions from Low-Voltage Electrical and Electronic Equipment in the Range of 9 kHz to 40 GHz.

[2] **FCC 47 CFR Part 2** General Rules and Regulations

[3] **FCC 47 CFR Part 15** Radio Frequency Devices (Subpart B)

2. SUMMARY OF TEST RESULTS

Test procedures according to the technical standards:

Emission				
Standard	Test Item	Limit	Judgment	Remark
FCC Part 15B	Conducted Emission	Class B	PASS	
	Radiated Emission	Class B	PASS	

2.1 MEASUREMENT UNCERTAINTY

The reported uncertainty of measurement $y \pm U$, where expanded uncertainty U is based on a standard uncertainty multiplied by a coverage factor of $k=2$, providing a level of confidence of approximately 95 %.

A. Conducted Measurement :

Test Site	Method	Measurement Frequency Range	U, (dB)	NOTE
C01	ANSI	150 KHz ~ 30MHz	2.54	

B. Radiated Measurement :

Test Site	Method	Measurement Frequency Range	Ant. H / V	U, (dB)	NOTE
OS02	ANSI	30MHz ~ 200MHz	V	3.0	
		30MHz ~ 200MHz	H	3.0	
		200MHz ~ 1,000MHz	V	3.0	
		200MHz ~ 1,000MHz	H	3.0	

2.2 DESCRIPTION OF TEST MODES

The EUT was tested together with the below additional components, and configuration (refer to clause 2.3 & 2.4), which produced the worst emission levels, was selected and recorded in this report.

The measurement was performed at 3 axis for lie orientation, side orientation and stand orientation. The lie orientation is the worst mode, so only the worst mode test data was reported.

The following test mode was recorder in this report.

Test Item	Test mode
Conduct Emission	N/A
Radiation Emission	Continuously Rx mode

2.3 BLOCK DIGRAM SHOWING THE CONFIGURATION OF SYSTEM TESTED

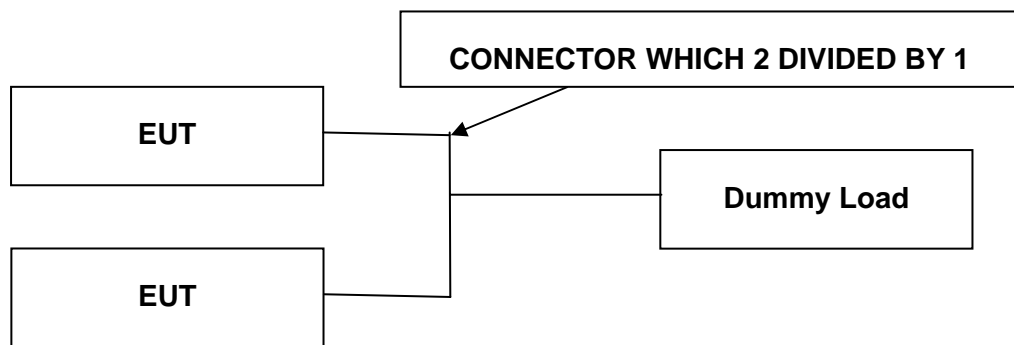

Note :

This is a WIRELESS REMOTE BATTERY PACKS which contain a remote, two battery packs with receiving function, a connector which 2 divided by 1 and a adaptor.

The battery packs will stop receiving when charging, and will return to receive when discharging,

Two battery packs can work at the same time, which will produce the worst emission levels, was selected and recorded in the report.



2.4 DESCRIPTION OF SUPPORT UNITS

The EUT has been tested as an independent unit together with other necessary accessories or support units. The following support units or accessories were used to form a representative test configuration during the tests.

No.	Equipment	Model No.	Serial No.	FCC ID	Trade Name	Data Cable	Power Cord
1	Load	BXT-15	/	/	ND	Unshielded, detachable,0.5m	/

Note:

- 1) All the equipment/cables were placed in the worst-case configuration to maximize the emission during the test.
- 2) Grounding was established in accordance with the manufacturer's requirements and conditions for the intended use.

2.5 EUT SYSTEM OPERATION

1. Set up EUT with the relative support equipments.
2. Make sure the EUT worked normally during the test

3. CONDUCTED EMISSION TEST

3.1 CONDUCTED EMISSION MEASUREMENT

3.1.1 LIMITS OF CONDUCTED EMISSION (MAINS PORT) (Frequency Range 150KHz-30MHz)

FREQUENCY (MHz)	Class A (dBuV)		Class B (dBuV)	
	Quasi-peak	Average	Quasi-peak	Average
0.15 -0.5	79.00	66.00	66 - 56 *	56 - 46 *
0.50 -5.0	73.00	60.00	56.00	46.00
5.0 -30.0	73.00	60.00	60.00	50.00

Note:

- (1) The tighter limit applies at the band edges.
- (2) The limit of " * " marked band means the limitation decreases linearly with the logarithm of the frequency in the range.

3.1.2 MEASUREMENT INSTRUMENTS LIST

Item	Kind of Equipment	Manufacturer	Type No.	Serial No.	Calibrated until
1	LISN	SCHWARZBECK MESS-ELEKTRONIK	NSLK 8127	8127-669	2015-06-27
2	Pulse Limiter	ROHDE&SCHWARZ	ESH3-Z2	101661	2015-06-27
3	Test Cable	N/A	C01	N/A	2015-06-27
4	EMI Test Receiver	ROHDE&SCHWARZ	ESCI	101358	2015-06-27

Remark: " N/A" denotes No Model No. , Serial No. or No Calibration specified.

3.1.3 TEST PROCEDURE

The EUT is put on the table that is 0.8m high above the ground and at least away from other Metallic surface 0.4m. The EUT is connected to the power mains through a line impedance stabilization network (L.I.S.N.). This provides a 50 ohms coupling impedance for the testing equipment; and the peripheral equipment powers form other L.I.S.N. Please refer to the block diagram of the test setup and photographs. Both sides of AC line (Line & Neutral) are checked for maximum conducted interference. In order to find the maximum emission levels, the relative positions of equipment and all of the interface cables must be changed according to FCC part 15 B.

The bandwidth of the field strength meter (R&S Test Receiver ESCI) is set at 120 KHz.

The frequency range from 150KHz to 30MHz is checked. The details of test modes are listed as follows, and the test data has been listed in section **3.1.7**

3.1.4 DEVIATION FROM TEST STANDARD

No deviation

3.1.5 TEST SETUP

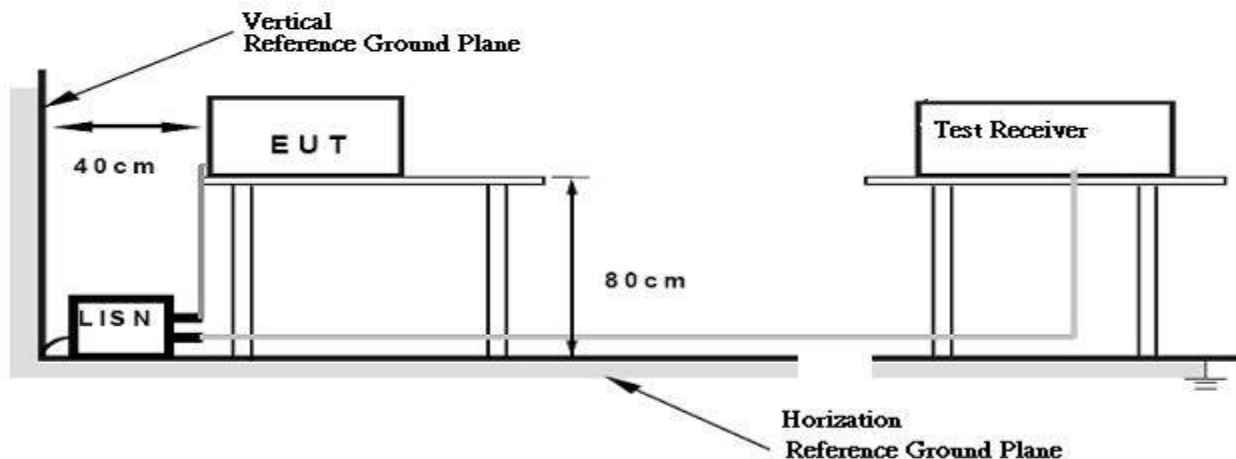

3.1.6 EUT OPERATING CONDITIONS

The EUT exercise program used during radiated and/or conducted emission measurement was designed to exercise the various system components in a manner similar to a typical use.

3.1.7 TEST RESULTS

No applicable to battery product.

3.2 RADIATED EMISSION MEASUREMENT

3.2.1 LIMITS OF RADIATED EMISSION MEASUREMENT (Below 1000MHz)

Frequency MHz	Class A (at 3m)	Class B (at 3m)
	dBuV/m	dBuV/m
30 ~ 88	49.0	40.0
88 ~ 216	53.5	43.5
216 ~ 960	56.4	46.0
960 ~ 1000	59.5	54.0

Notes:

- (1) The limit for radiated test was performed according to as following:
FCC PART 15B
- (2) The tighter limit applies at the band edges.
- (3) Emission level (dBuV/m)=20log Emission level (uV/m).

LIMITS OF RADIATED EMISSION MEASUREMENT (Above 1000MHz)

FREQUENCY (GHz)	Class A (dBuV/m) (at 3m)		Class B (dBuV/m) (at 3m)	
	PEAK	AVERAGE	PEAK	AVERAGE
Above 1000MHz	79.5	59.5	74.0	54.0

Notes:

- (1) The limit for radiated test was performed according to FCC PART 15B.
- (2) The tighter limit applies at the band edges.
- (3) Emission level (dBuV/m)=20log Emission level (uV/m).

FREQUENCY RANGE OF RADIATED MEASUREMENT (For unintentional radiators)

Highest frequency generated or Upper frequency of measurement used in the device or on which the device operates or tunes (MHz)	Range (MHz)
Below 1.705	30
1.705 – 108	1000
108 – 500	2000
500 – 1000	5000
Above 1000	5 th harmonic of the highest frequency or 40 GHz, whichever is lower



3.2.2 MEASUREMENT INSTRUMENTS LIST

Item	Kind of Equipment	Manufacturer	Type No.	Serial No.	Calibrated until
1	Log-Bicon Antenna	SCHWARZBECK MESS	VULB 9163	9163-588	2015-06-28
2	Test Cable	N/A	10M_OS01	N/A	2015-07-01
3	Test Cable	N/A	C01-1/-2	N/A	2015-07-01
4	Pre-Amplifier	HP	8447D	N/A	2015-07-01
5	Spectrum Analyzer	Agilent	E4407B	N/A	2015-06-28
6	Test Receiver	ROHDE&SCHWARZ	ESVD	832497/002	2015-06-27
7	Antenna Mast	N/A	N/A	N/A	N/A
8	Turn Table	N/A	N/A	N/A	N/A
9	Positioning Controller	Max-Full Antenna Corp.	MF7802	N/A	N/A

Remark: " N/A" denotes No Model No. / Serial No. and No Calibration specified.

3.2.3 TEST PROCEDURE

- The EUT was placed on a turn table which was 0.8 meter above ground. The turn table can rotate 360 degrees to determine the position of the maximum emission level. The EUT was set 3 meters away from the receiving antenna which was mounted on a antenna tower. At the frequency of 30 MHz~1000MHz ,the measuring antenna moved up and down to find out the maximum emission level. It moved from 1 to 4 m for horizontal and vertical polarizations. The broadband antenna was used as a receiving antenna. At the frequency of 1 GHz -5GHz ,the measuring antenna stands 1 m for horizontal and vertical polarizations. The horn antenna was used as a receiving antenna.
- The bandwidth setting on the test receiver was 120 KHz(30 MHz~1000MHz).
- The bandwidth setting on the test receiver was 1MHz(1 GHz~5GHz).
- The test data of the worst-case condition(s) was recorded.

3.2.4 DEVIATION FROM TEST STANDARD

No deviation

3.2.5 TEST SETUP

Below 1GHz

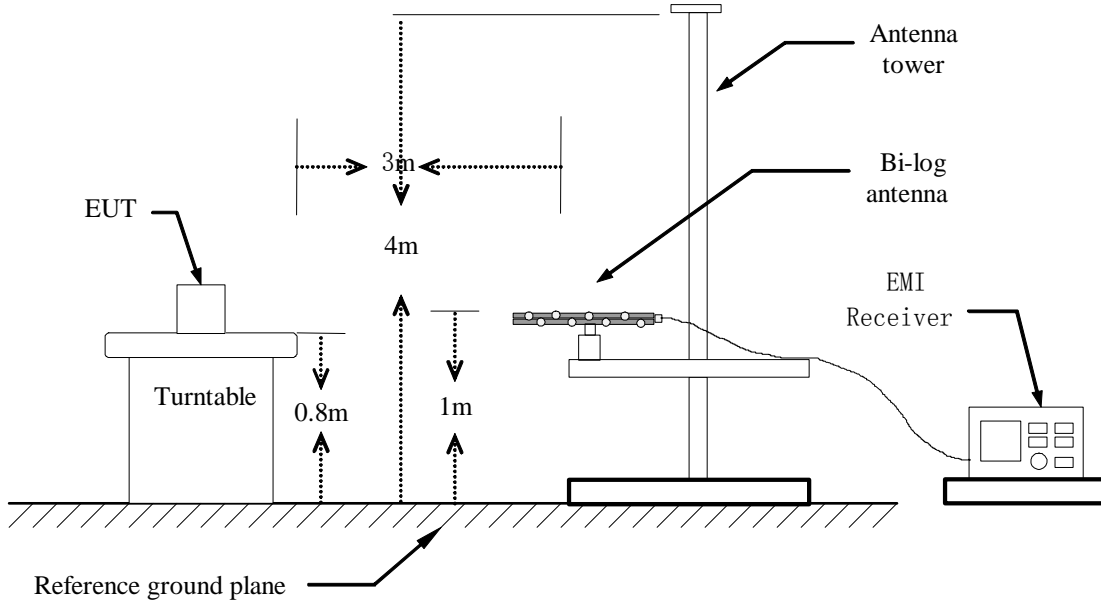

Above 1GHz

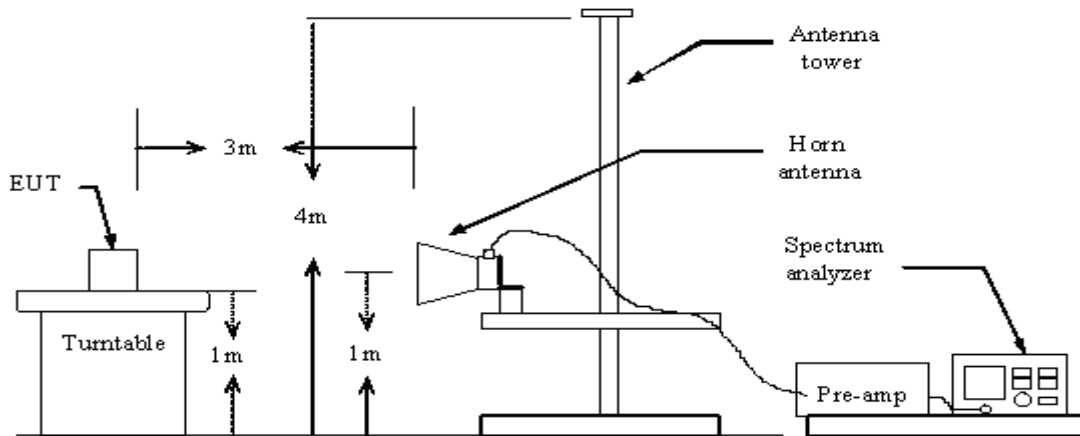

3.2.6 EUT OPERATING CONDITIONS

The EUT tested system was configured as the statements of 3.1.6 Unless otherwise a special operating condition is specified in the follows during the testing.



3.2.7 TEST RESULTS

EUT:	WIRELESS REMOTE BATTERY PACKS	Model No. :	BP037202-VB320R
Temperature:	24.5°C	Relative Humidity:	55 %
Pressure:	1008 hPa	Test Power :	DC 4.2V
Test Mode :	Discharging		

Remark:

- (1) Reading in which marked as QP or Peak means measurements by using are Quasi-Peak Detector or Peak Detector.
- (2) All readings are Peak unless otherwise stated QP in column of 『Note』 . Peak denotes that the Peak reading compliance with the QP Limits and then QP Mode measurement didn't perform.
- (3) Measuring frequency range from 30MHz to 1000MHz.
- (4) If the peak scan value lower limit more than 20dB, then this signal data does not how in table.



FCC ID: 2ADDXBP037202
 Report No.: EA1410010F 01001

14 of 17

Radiated Emission Test Result

Test Site : 966 Chamber F:\Test Data.EM6
Test Date : 2014-10-27 **Tested By** : Tiger
EUT : WIRELESS REMOTE BATTERY **Model Number** : BP037202-VB320R
 : PACKS
Power Supply : DC 4.2V **Test Mode** : Discharging
Condition : Temp:24.5°C ,Humi:55% **Antenna/Distance** : VULB9163-1/3m/VERTICAL
Memo :

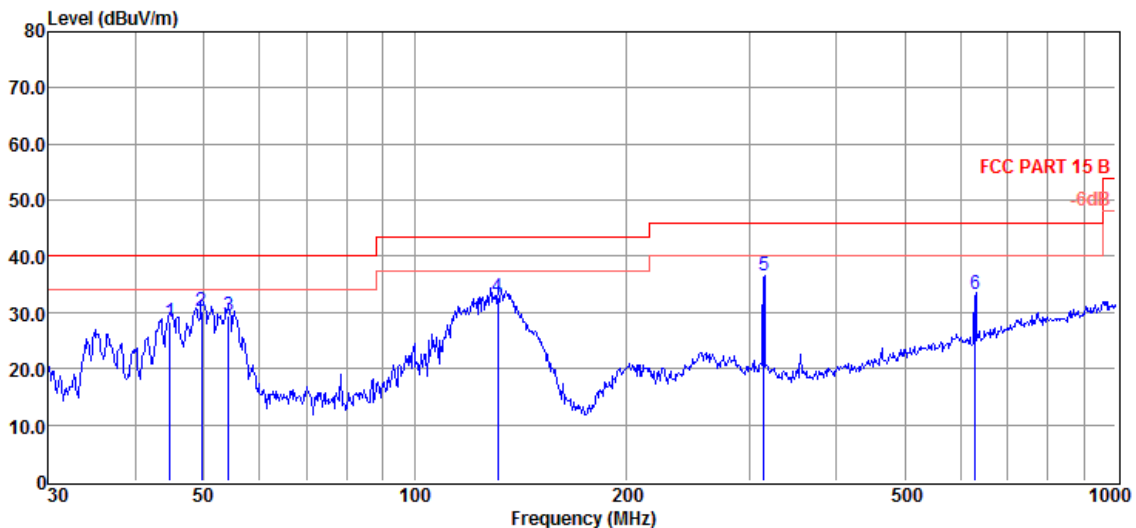

Item (Mark)	Freq (MHz)	Read Level (dBμV)	Antenna Factor (dB/m)	PRM Factor dB	Cable Loss dB	Result Level (dBμV/m)	Limit Line (dBμV/m)	Over Limit (dB)	Detector	Polarization
1	44.80	38.71	13.20	25.00	1.32	28.23	40.00	-11.77	QP	VERTICAL
2	49.71	40.58	13.25	25.00	1.35	30.18	40.00	-9.82	QP	VERTICAL
3	54.26	39.96	12.99	25.00	1.37	29.32	40.00	-10.68	QP	VERTICAL
4	131.20	48.20	7.60	25.00	1.80	32.60	43.50	-10.90	QP	VERTICAL
5	315.00	45.30	13.49	25.00	2.81	36.60	46.00	-9.40	QP	VERTICAL
6	630.00	34.51	19.17	25.00	4.54	33.22	46.00	-12.78	QP	VERTICAL

Note: 1. Result Level = Read Level + Antenna Factor + Cable loss - PRM Factor
 2. If Peak Result comply with QP limit, QP Result is deemed to comply with QP limit

Radiated Emission Test Result

Test Site	: 966 Chamber	F:\Test Data.EM6	
Test Date	: 2014-10-27	Tested By	: Tiger
EUT	: WIRELESS REMOTE BATTERY : PACKS	Model Number	: BP037202-VB320R
Power Supply	: DC 4.2V	Test Mode	: Discharging
Condition	: Temp:24.5°C,Humi:55%	Antenna/Distance	: VULB9163-1/3m/HORIZONTAL
Memo	:		

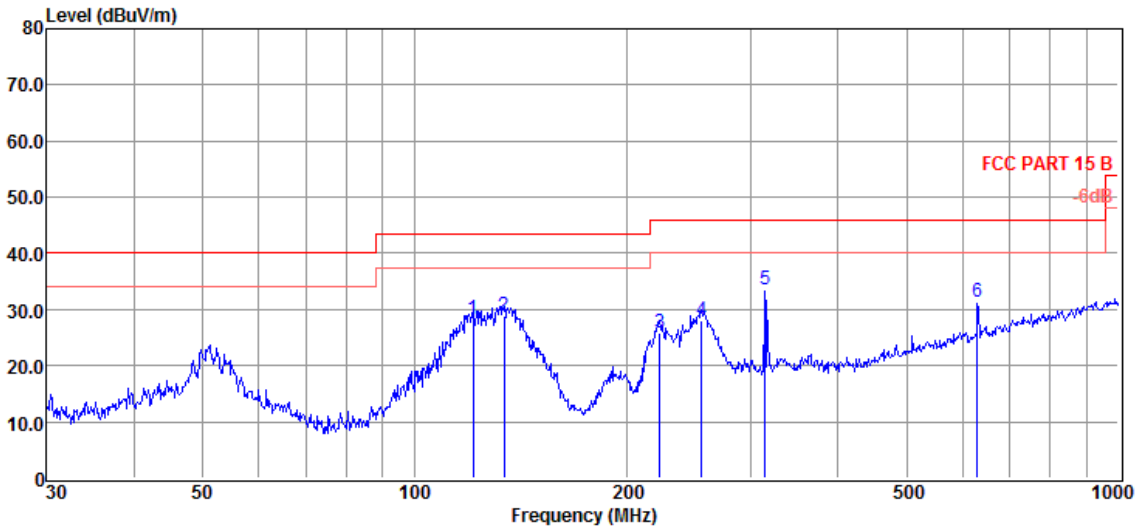

Item (Mark)	Freq (MHz)	Read Level (dBμV)	Antenna Factor (dB/m)	PRM Factor dB	Cable Loss dB	Result Level (dBμV/m)	Limit Line (dBμV/m)	Over Limit (dB)	Detector	Polarization
1	121.12	42.56	8.95	25.00	1.74	28.25	43.50	-15.25	QP	HORIZONTAL
2	134.09	44.51	7.42	25.00	1.81	28.74	43.50	-14.76	QP	HORIZONTAL
3	222.95	37.50	11.14	25.00	2.30	25.94	46.00	-20.06	QP	HORIZONTAL
4	255.62	38.21	12.30	25.00	2.48	27.99	46.00	-18.01	QP	HORIZONTAL
5	315.00	42.30	13.49	25.00	2.81	33.60	46.00	-12.40	QP	HORIZONTAL
6	630.00	32.51	19.17	25.00	4.54	31.22	46.00	-14.78	QP	HORIZONTAL

Note: 1. Result Level = Read Level + Antenna Factor + Cable loss - PRM Factor
 2. If Peak Result comply with QP limit, QP Result is deemed to comply with QP limit



Radiated Emission Test Result

Test Site	: 966 Chamber	F:\Test Data\-.EM6
Test Date	: 2014-10-27	Tested By : Tiger
EUT	: WIRELESS REMOTE BATTERY PACKS	Model Number : BP037202-VB320R
Power Supply	: DC 4.2V	Test Mode : Discharging
Condition	: Temp:24.5°C,Humi:55%	Antenna/Distance : ANT FACTOR >1G/(3m)

Memo :

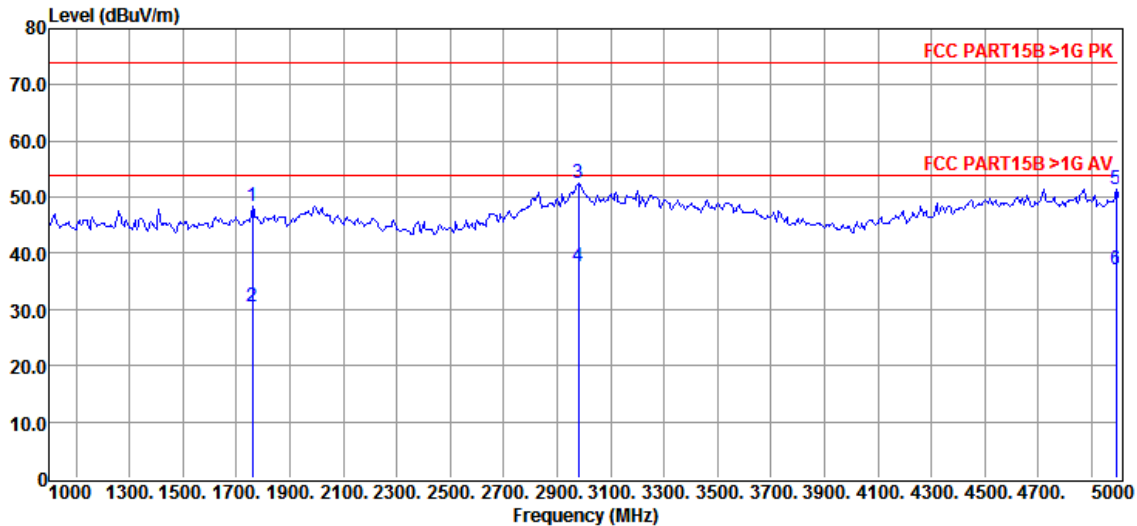

Item (Mark)	Freq (MHz)	Read Level (dBμV)	Factor dB	Level (dBμV/m)	Limit Line (dBμV/m)	Over Limit (dB)	Detector	Polarization
1	1760.00	38.39	10.08	48.47	74.00	-25.53	Peak	VERTICAL
2	1760.00	20.41	10.08	30.49	54.00	-23.51	Average	VERTICAL
3	2980.00	36.43	16.18	52.61	74.00	-21.39	Peak	VERTICAL
4	2980.00	21.60	16.18	37.78	54.00	-16.22	Average	VERTICAL
5	4992.00	30.67	20.79	51.46	74.00	-22.54	Peak	VERTICAL
6	4992.00	16.40	20.79	37.19	54.00	-16.81	Average	VERTICAL

Note: 1. Result Level = Read Level + Factor
 2. If PK Result complies with AV limit, AV Result is deemed to comply with AV limit



Radiated Emission Test Result

Test Site : 966 Chamber **F:\Test Data\-.EM6**
Test Date : 2014-10-27 **Tested By** : Tiger
EUT : WIRELESS REMOTE BATTERY PACKS **Model Number** : BP037202-VB320R
Power Supply : DC 4.2V **Test Mode** : Discharging
Condition : Temp:24.5°C,Humi:55% **Antenna/Distance** : ANT FACTOR >1G/(3m)
Memo :

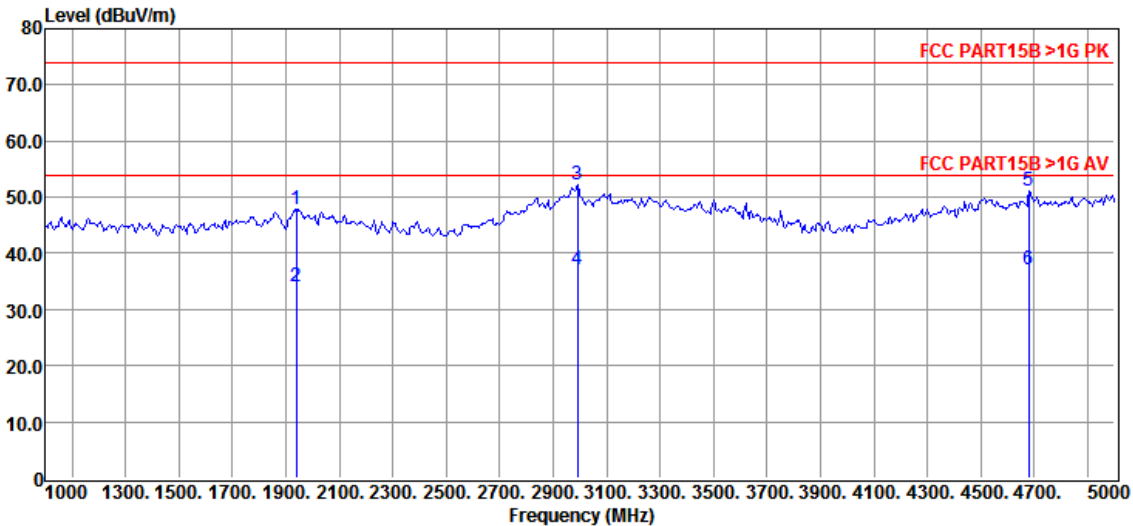

Item (Mark)	Freq (MHz)	Read Level (dBμV)	Factor dB	Level (dBμV/m)	Limit Line (dBμV/m)	Over Limit (dB)	Detector	Polarization
1	1940.00	36.24	11.68	47.92	74.00	-26.08	Peak	HORIZONTAL
2	1940.00	22.49	11.68	34.17	54.00	-19.83	Average	HORIZONTAL
3	2992.00	35.80	16.31	52.11	74.00	-21.89	Peak	HORIZONTAL
4	2992.00	20.80	16.31	37.11	54.00	-16.89	Average	HORIZONTAL
5	4680.00	30.89	20.23	51.12	74.00	-22.88	Peak	HORIZONTAL
6	4680.00	16.89	20.23	37.12	54.00	-16.88	Average	HORIZONTAL

Note: 1. Result Level = Read Level + Factor
 2. If PK Result complies with AV limit, AV Result is deemed to comply with AV limit