

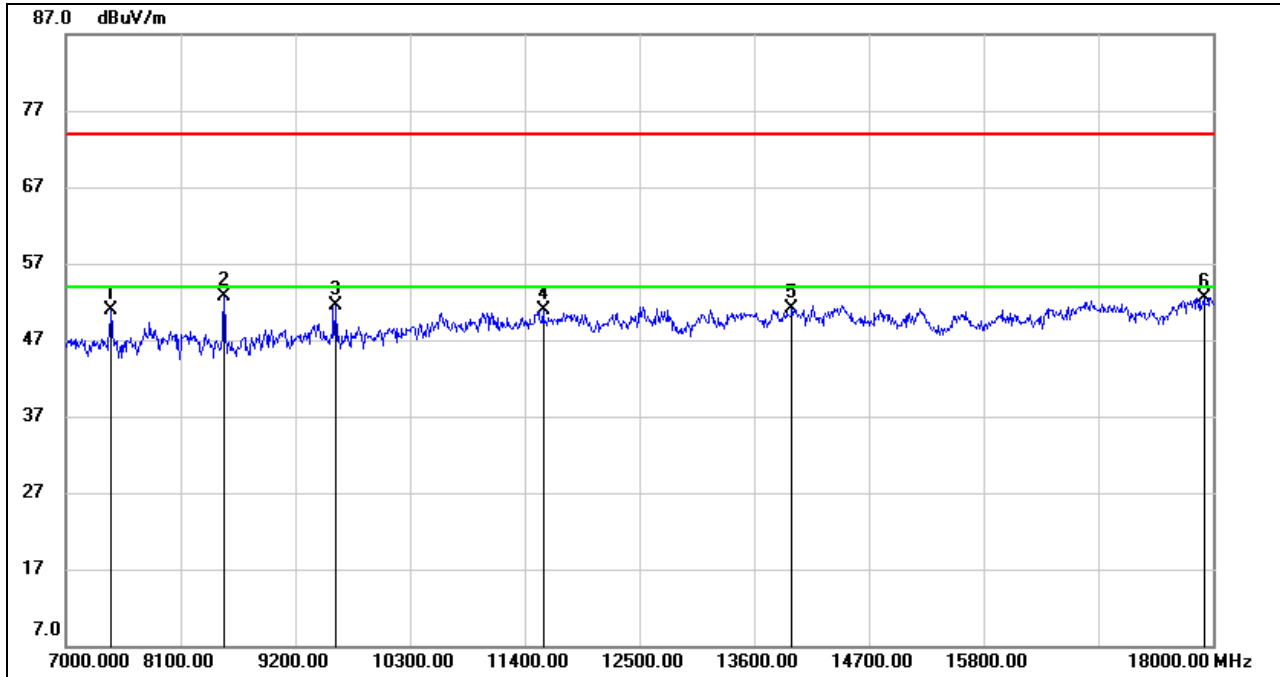

VERTICAL RESULTS
7-18GHz



No.	Frequency (MHz)	Reading (dBuV)	Correct (dB/m)	Result (dBuV/m)	Limit (dBuV/m)	Margin (dB)	Remark
1	7429.000	42.57	8.28	50.85	74.00	-23.15	peak
2	8518.000	43.49	9.21	52.70	74.00	-21.30	peak
3	9585.000	40.85	10.62	51.47	74.00	-22.53	peak
4	11576.000	36.29	14.60	50.89	74.00	-23.11	peak
5	13963.000	34.35	16.75	51.10	74.00	-22.90	peak
6	17912.000	29.02	23.40	52.42	74.00	-21.58	peak

Note: 1. Measurement = Reading Level + Correct Factor.
 2. If Peak Result complies with AV limit, AV Result is deemed to comply with AV limit.
 3. Peak: Peak detector.
 4. Filter losses were only considered in the spurious frequency bands and the authorized band was not corrected for HPF losses.
 5. Proper operation of the transmitter prior to adding the filter to the measurement chain.
 6. Owing to the highest peak level complies with the lowest limit of unwanted emission out of the restricted bands (Please refer to page 72), so all the test point were deemed to comply with the limits list in the standard.



HARMONICS AND SPURIOUS EMISSIONS HIGH CHANNEL

HORIZONTAL RESULTS
1-7GHz

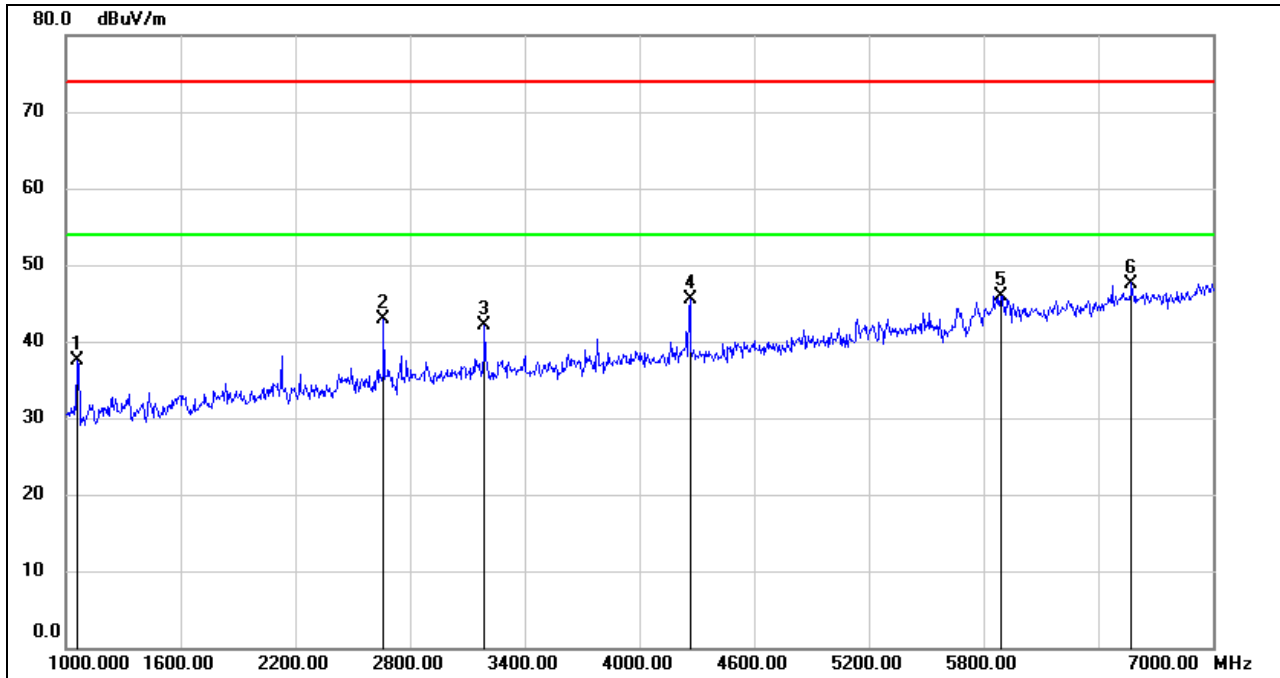

No.	Frequency (MHz)	Reading (dBuV)	Correct (dB/m)	Result (dBuV/m)	Limit (dBuV/m)	Margin (dB)	Remark
1	1060.000	51.93	-14.51	37.42	74.00	-36.58	peak
2	2662.000	51.06	-8.18	42.88	74.00	-31.12	peak
3	3190.000	48.06	-5.94	42.12	74.00	-31.88	peak
4	4264.000	48.54	-3.11	45.43	74.00	-28.57	peak
5	5890.000	41.25	4.68	45.93	74.00	-28.07	peak
6	6574.000	41.99	5.61	47.60	74.00	-26.40	peak

Note: 1. Measurement = Reading Level + Correct Factor.
 2. If Peak Result complies with AV limit, AV Result is deemed to comply with AV limit.
 3. Peak: Peak detector.
 4. Filter losses were only considered in then spurious frequency bands and the authorized band was not corrected for BRF losses.
 5. Proper operation of the transmitter prior to adding the filter to the measurement chain.
 6. Owing to the highest peak level complies with the lowest limit of unwanted emission out of the restricted bands (Please refer to page 72), so all the test point were deemed to comply with the limits list in the standard.



HORIZONTAL RESULTS
7-18GHz

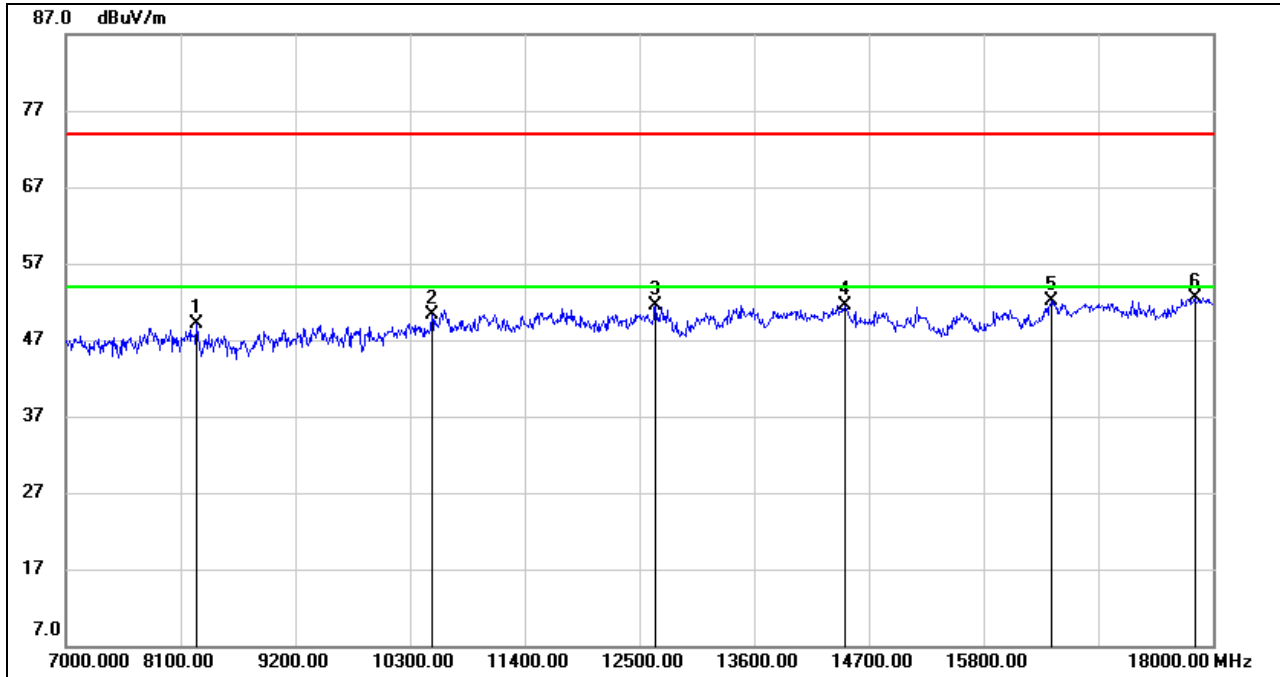

No.	Frequency (MHz)	Reading (dBuV)	Correct (dB/m)	Result (dBuV/m)	Limit (dBuV/m)	Margin (dB)	Remark
1	8254.000	39.34	9.67	49.01	74.00	-24.99	peak
2	10509.000	37.83	12.39	50.22	74.00	-23.78	peak
3	12654.000	36.71	14.73	51.44	74.00	-22.56	peak
4	14469.000	34.67	16.90	51.57	74.00	-22.43	peak
5	16449.000	32.44	19.61	52.05	74.00	-21.95	peak
6	17824.000	29.13	23.45	52.58	74.00	-21.42	peak

Note: 1. Measurement = Reading Level + Correct Factor.
 2. If Peak Result complies with AV limit, AV Result is deemed to comply with AV limit.
 3. Peak: Peak detector.
 4. Filter losses were only considered in the spurious frequency bands and the authorized band was not corrected for HPF losses.
 5. Proper operation of the transmitter prior to adding the filter to the measurement chain.
 6. Owing to the highest peak level complies with the lowest limit of unwanted emission out of the restricted bands (Please refer to page 72), so all the test point were deemed to comply with the limits list in the standard.



VERTICAL RESULTS

1-7GHz

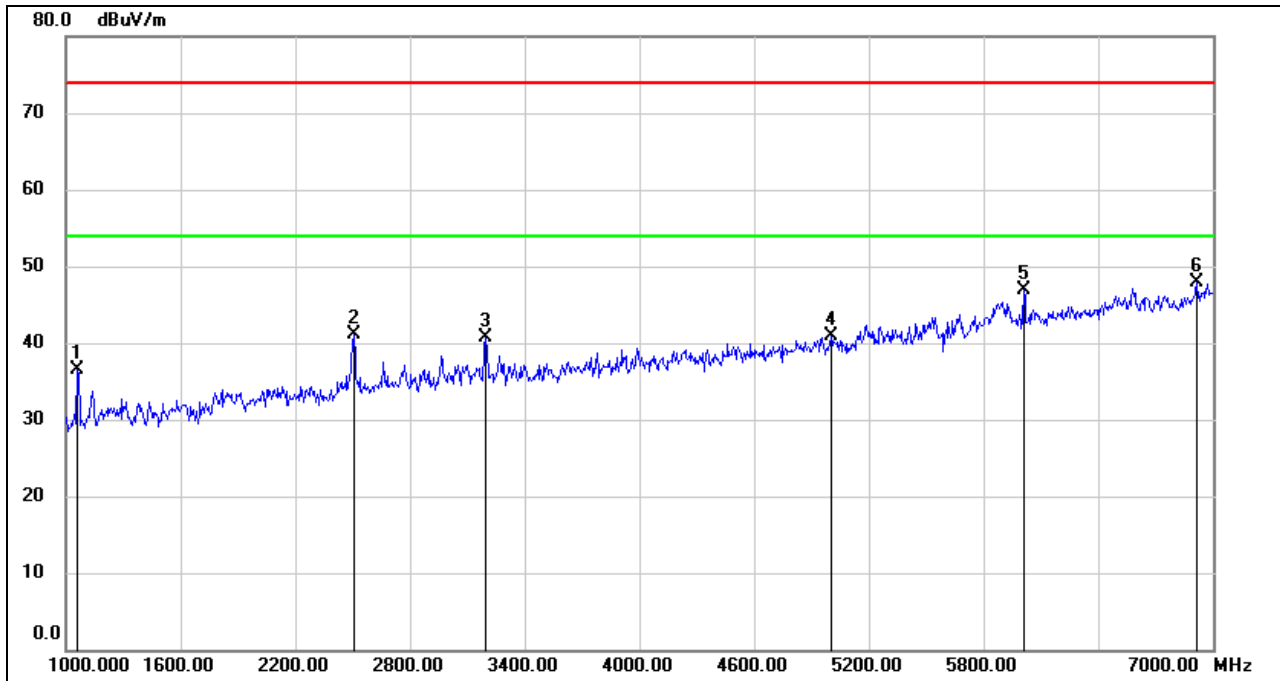

No.	Frequency (MHz)	Reading (dBuV)	Correct (dB/m)	Result (dBuV/m)	Limit (dBuV/m)	Margin (dB)	Remark
1	1060.000	51.01	-14.51	36.50	74.00	-37.50	peak
2	2506.000	49.23	-8.18	41.05	74.00	-32.95	peak
3	3196.000	46.75	-5.96	40.79	74.00	-33.21	peak
4	5002.000	40.97	-0.06	40.91	74.00	-33.09	peak
5	6010.000	43.61	3.30	46.91	74.00	-27.09	peak
6	6916.000	41.50	6.31	47.81	74.00	-26.19	peak

Note: 1. Measurement = Reading Level + Correct Factor.
 2. If Peak Result complies with AV limit, AV Result is deemed to comply with AV limit.
 3. Peak: Peak detector.
 4. Filter losses were only considered in then spurious frequency bands and the authorized band was not corrected for BRF losses.
 5. Proper operation of the transmitter prior to adding the filter to the measurement chain.
 6. Owing to the highest peak level complies with the lowest limit of unwanted emission out of the restricted bands (Please refer to page 72), so all the test point were deemed to comply with the limits list in the standard.



VERTICAL RESULTS
7-18GHz

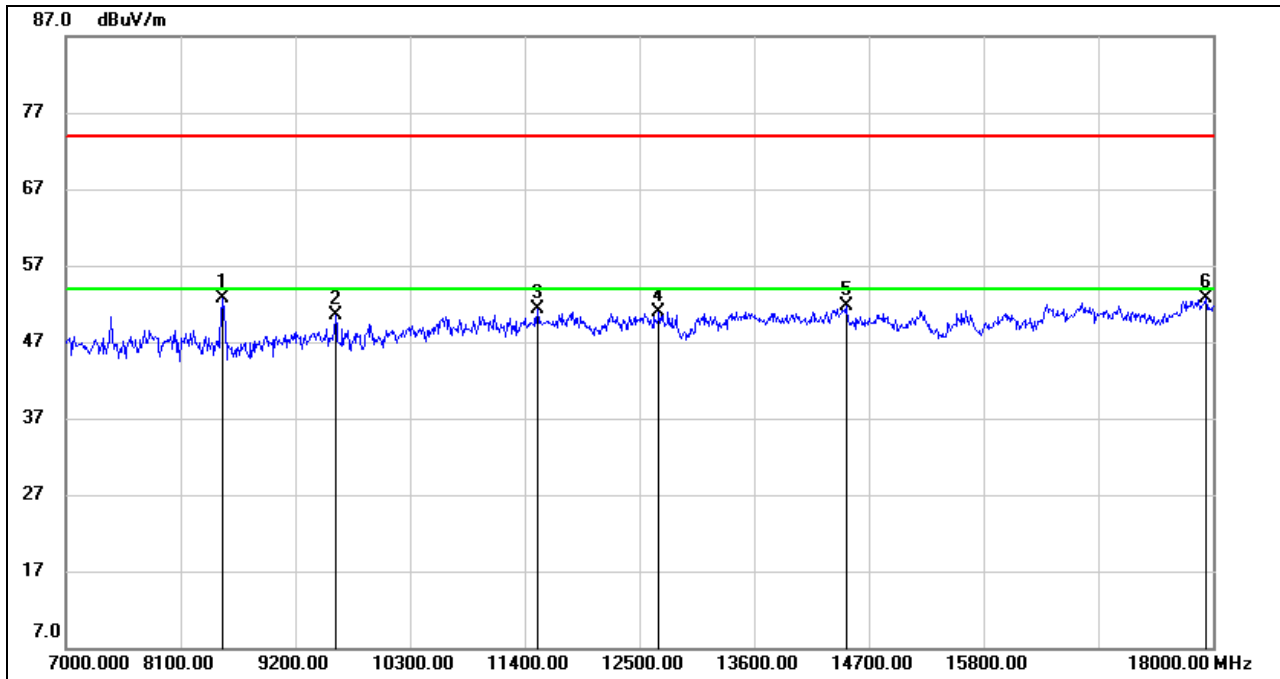

No.	Frequency (MHz)	Reading (dBuV)	Correct (dB/m)	Result (dBuV/m)	Limit (dBuV/m)	Margin (dB)	Remark
1	8507.000	43.38	9.24	52.62	74.00	-21.38	peak
2	9585.000	39.93	10.62	50.55	74.00	-23.45	peak
3	11521.000	36.86	14.48	51.34	74.00	-22.66	peak
4	12687.000	36.11	14.79	50.90	74.00	-23.10	peak
5	14480.000	34.76	16.87	51.63	74.00	-22.37	peak
6	17934.000	29.32	23.42	52.74	74.00	-21.26	peak

Note: 1. Measurement = Reading Level + Correct Factor.
 2. If Peak Result complies with AV limit, AV Result is deemed to comply with AV limit.
 3. Peak: Peak detector.
 4. Filter losses were only considered in the spurious frequency bands and the authorized band was not corrected for HPF losses.
 5. Proper operation of the transmitter prior to adding the filter to the measurement chain.
 6. Owing to the highest peak level complies with the lowest limit of unwanted emission out of the restricted bands (Please refer to page 72), so all the test point were deemed to comply with the limits list in the standard.



7.3.4. STRADDLE CHANNEL 142

HARMONICS AND SPURIOUS EMISSIONS HIGH CHANNEL

HORIZONTAL RESULTS
1-7GHz

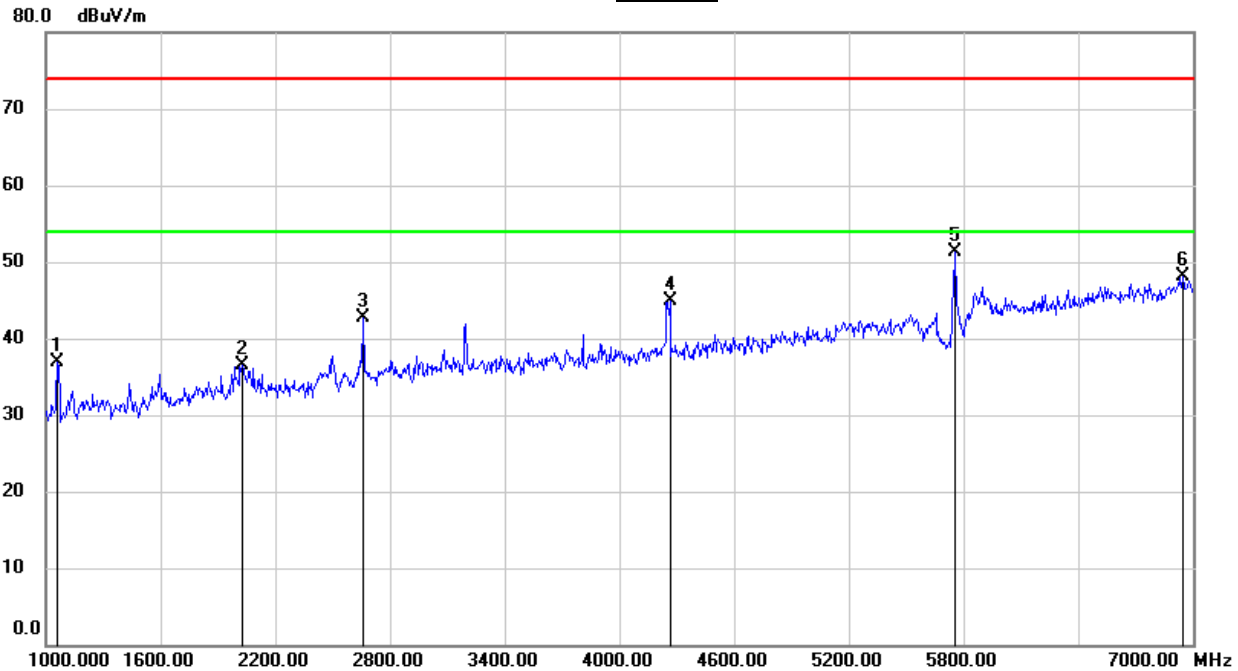

No.	Frequency (MHz)	Reading (dBuV)	Correct (dB/m)	Result (dBuV/m)	Limit (dBuV/m)	Margin (dB)	Remark
1	1060.000	51.45	-14.51	36.94	74.00	-37.06	peak
2	2026.000	47.14	-10.68	36.46	74.00	-37.54	peak
3	2662.000	50.90	-8.18	42.72	74.00	-31.28	peak
4	4264.000	48.07	-3.11	44.96	74.00	-29.04	peak
5	5758.000	48.62	2.62	51.24	74.00	-22.76	peak
6	6946.000	41.79	6.34	48.13	74.00	-25.87	peak

Note: 1. Measurement = Reading Level + Correct Factor.
 2. If Peak Result complies with AV limit, AV Result is deemed to comply with AV limit.
 3. Peak: Peak detector.
 4. Filter losses were only considered in then spurious frequency bands and the authorized band was not corrected for BRF losses.
 5. Proper operation of the transmitter prior to adding the filter to the measurement chain.
 6. Owing to the highest peak level complies with the lowest limit of unwanted emission out of the restricted bands (Please refer to page 72), so all the test point were deemed to comply with the limits list in the standard.



HORIZONTAL RESULTS
7-18GHz

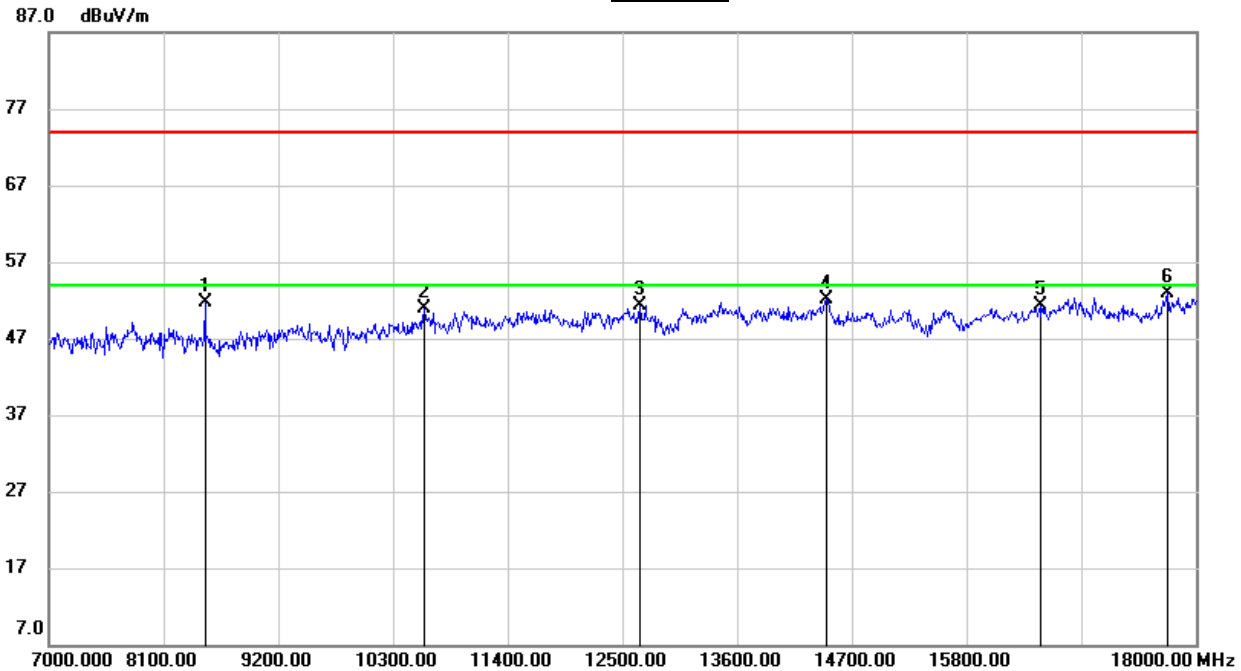

No.	Frequency (MHz)	Reading (dBuV)	Correct (dB/m)	Result (dBuV/m)	Limit (dBuV/m)	Margin (dB)	Remark
1	8496.000	42.35	9.26	51.61	74.00	-22.39	peak
2	10597.000	37.55	13.38	50.93	74.00	-23.07	peak
3	12665.000	36.61	14.76	51.37	74.00	-22.63	peak
4	14458.000	35.11	16.91	52.02	74.00	-21.98	peak
5	16504.000	31.56	19.80	51.36	74.00	-22.64	peak
6	17725.000	30.15	22.80	52.95	74.00	-21.05	peak

- Note: 1. Measurement = Reading Level + Correct Factor.
 2. If Peak Result complies with AV limit, AV Result is deemed to comply with AV limit.
 3. Peak: Peak detector.
 4. Filter losses were only considered in the spurious frequency bands and the authorized band was not corrected for HPF losses.
 5. Proper operation of the transmitter prior to adding the filter to the measurement chain.
 6. Owing to the highest peak level complies with the lowest limit of unwanted emission out of the restricted bands (Please refer to page 72), so all the test point were deemed to comply with the limits list in the standard.



VERTICAL RESULTS

1-7GHz

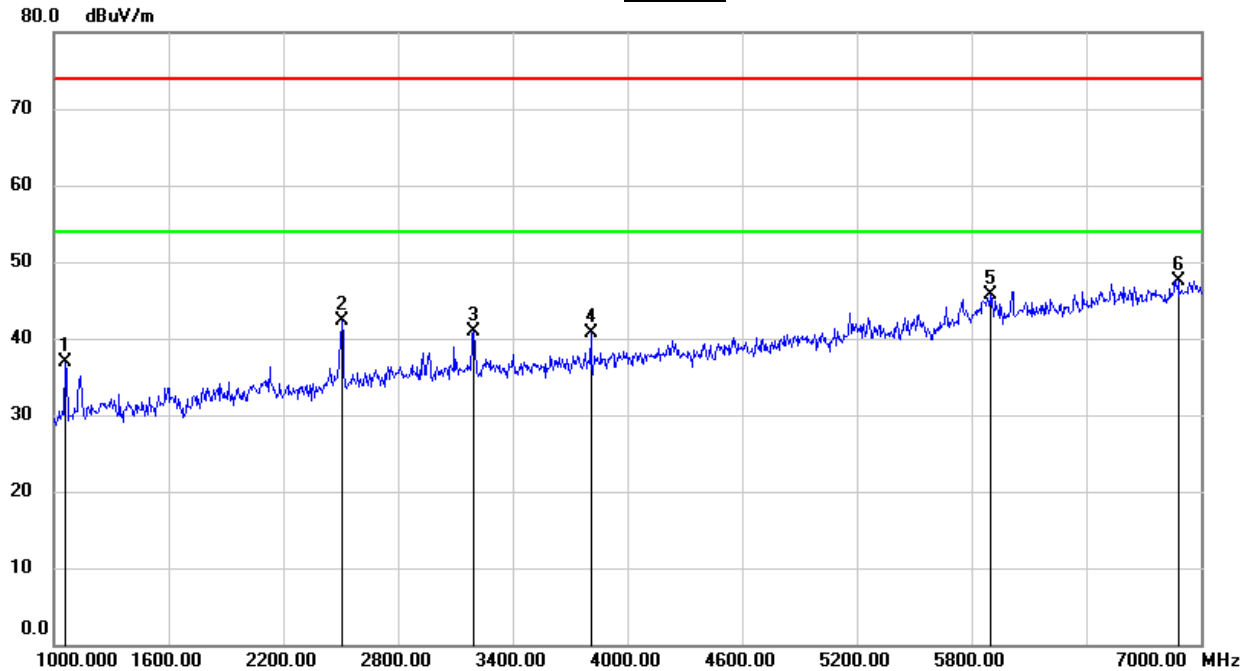

No.	Frequency (MHz)	Reading (dBuV)	Correct (dB/m)	Result (dBuV/m)	Limit (dBuV/m)	Margin (dB)	Remark
1	1060.000	51.33	-14.51	36.82	74.00	-37.18	peak
2	2506.000	50.39	-8.18	42.21	74.00	-31.79	peak
3	3196.000	46.90	-5.96	40.94	74.00	-33.06	peak
4	3808.000	44.91	-4.22	40.69	74.00	-33.31	peak
5	5896.000	40.93	4.79	45.72	74.00	-28.28	peak
6	6880.000	41.40	6.15	47.55	74.00	-26.45	peak

- Note: 1. Measurement = Reading Level + Correct Factor.
 2. If Peak Result complies with AV limit, AV Result is deemed to comply with AV limit.
 3. Peak: Peak detector.
 4. Filter losses were only considered in then spurious frequency bands and the authorized band was not corrected for BRF losses.
 5. Proper operation of the transmitter prior to adding the filter to the measurement chain.
 6. Owing to the highest peak level complies with the lowest limit of unwanted emission out of the restricted bands (Please refer to page 72), so all the test point were deemed to comply with the limits list in the standard.



7-18GHz

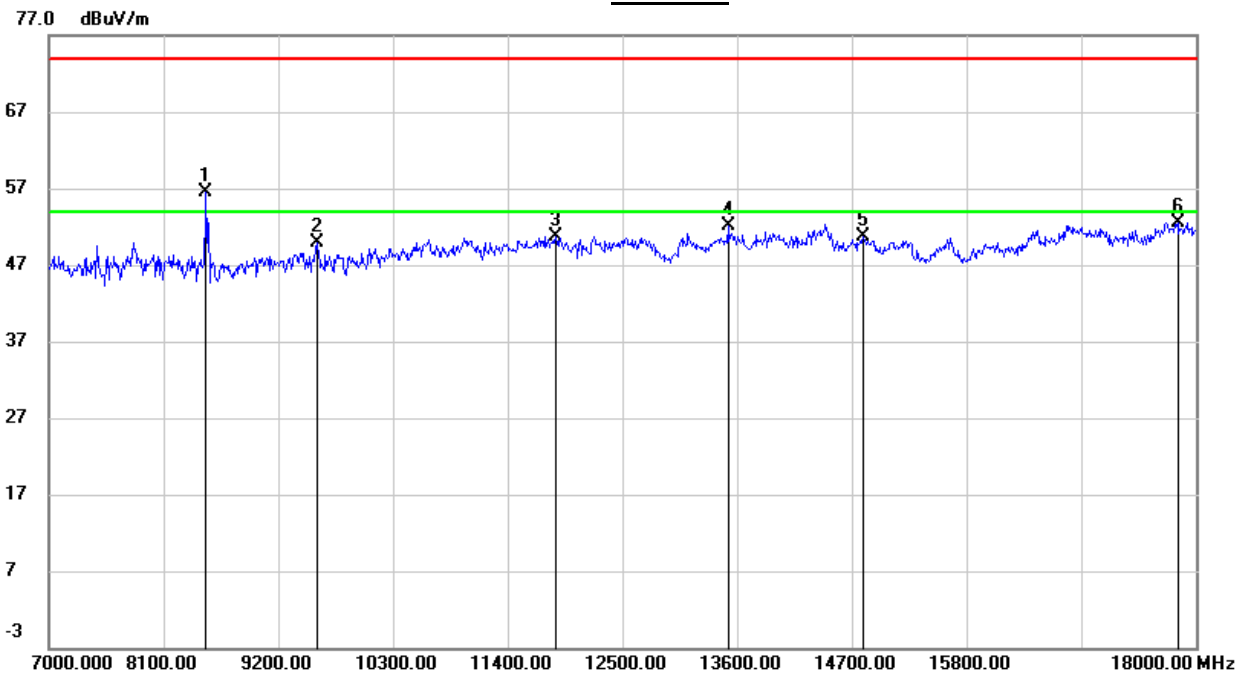

No.	Frequency (MHz)	Reading (dBuV)	Correct (dB/m)	Result (dBuV/m)	Limit (dBuV/m)	Margin (dB)	Remark
1*	8507.000	47.18	9.24	56.42	68.20	-11.78	peak
2	9574.000	39.24	10.64	49.88	74.00	-24.12	peak
3	11862.000	36.31	14.47	50.78	74.00	-23.22	peak
4	13512.000	35.77	16.25	52.02	74.00	-21.98	peak
5	14810.000	34.52	16.12	50.64	74.00	-23.36	peak
6	17824.000	29.08	23.45	52.53	74.00	-21.47	peak

- Note: 1. Measurement = Reading Level + Correct Factor.
 2. If Peak Result complies with AV limit, AV Result is deemed to comply with AV limit.
 3. Peak: Peak detector.
 4. Filter losses were only considered in the spurious frequency bands and the authorized band was not corrected for HPF losses.
 5. Proper operation of the transmitter prior to adding the filter to the measurement chain.
 6. Owing to the highest peak level complies with the lowest limit of unwanted emission out of the restricted bands (Please refer to page 72), so all the test point were deemed to comply with the limits list in the standard.
 7. *indicates frequency out of the restricted bands



7.3.5. UNII-3 BAND

RESTRICTED BANDEDGE LOW CHANNEL

HORIZONTAL RESULTS

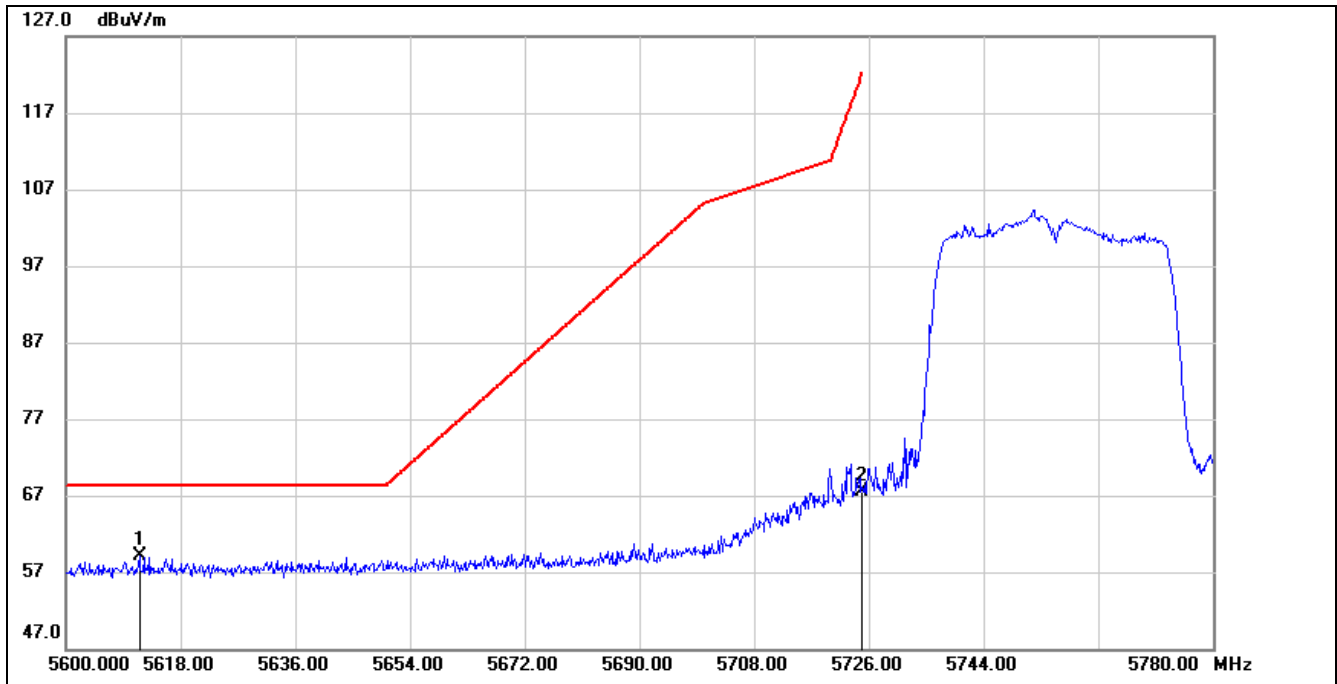

No.	Frequency (MHz)	Reading (dBuV)	Correct (dB/m)	Result (dBuV/m)	Limit (dBuV/m)	Margin (dB)	Remark
1	5611.520	17.62	41.46	59.08	68.20	-9.12	peak
2	5725.000	25.81	41.61	67.42	122.20	-54.78	peak

Note: 1. Measurement = Reading Level + Correct Factor.



VERTICAL RESULTS

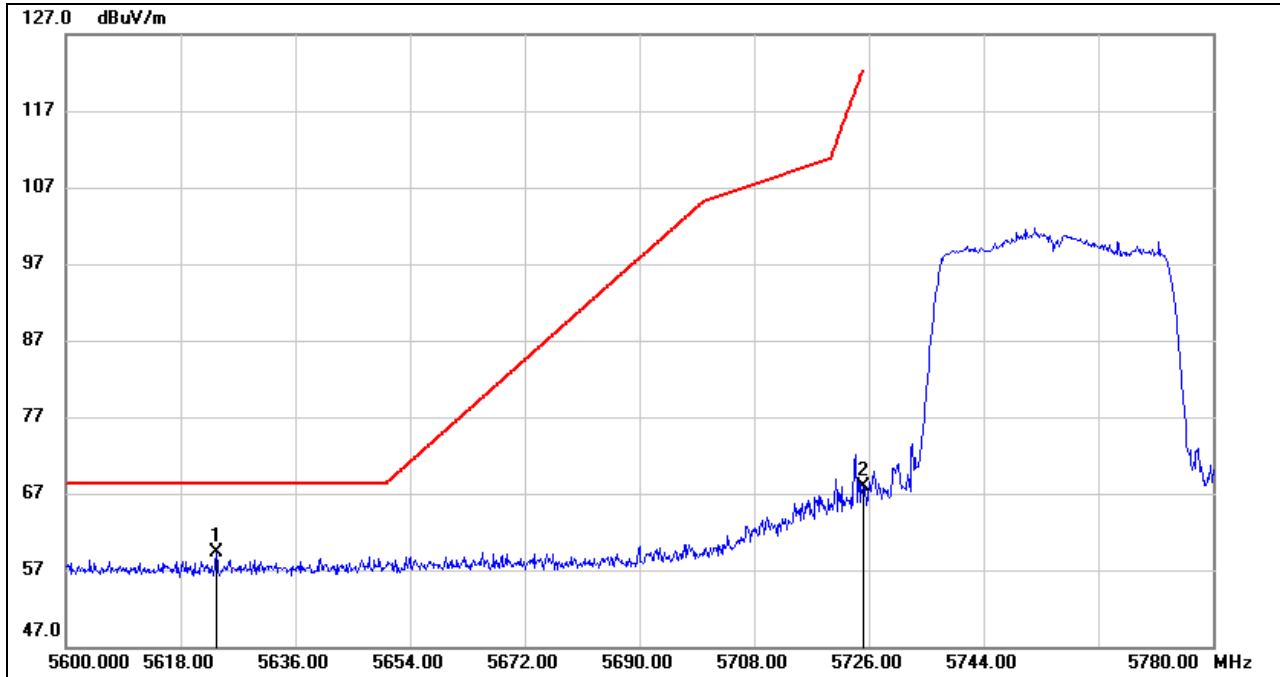

No.	Frequency (MHz)	Reading (dBuV)	Correct (dB/m)	Result (dBuV/m)	Limit (dBuV/m)	Margin (dB)	Remark
1	5623.580	17.80	41.47	59.27	68.20	-8.93	peak
2	5725.000	26.20	41.61	67.81	122.20	-54.39	peak

Note: 1. Measurement = Reading Level + Correct Factor.



RESTRICTED BANDEDGE HIGH CHANNEL

HORIZONTAL RESULTS

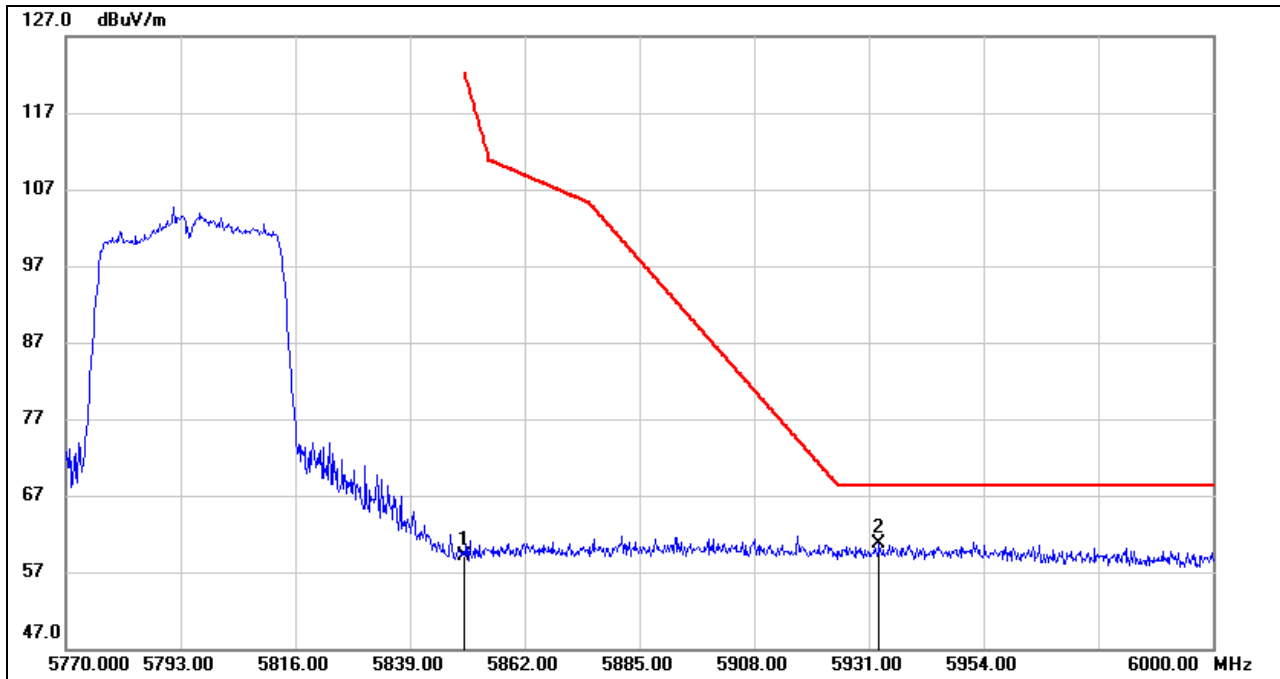

No.	Frequency (MHz)	Reading (dBuV)	Correct (dB/m)	Result (dBuV/m)	Limit (dBuV/m)	Margin (dB)	Remark
1	5850.000	16.29	42.89	59.18	122.20	-63.02	peak
2	5933.070	17.35	43.28	60.63	68.20	-7.57	peak

Note: 1. Measurement = Reading Level + Correct Factor.



VERTICAL RESULTS

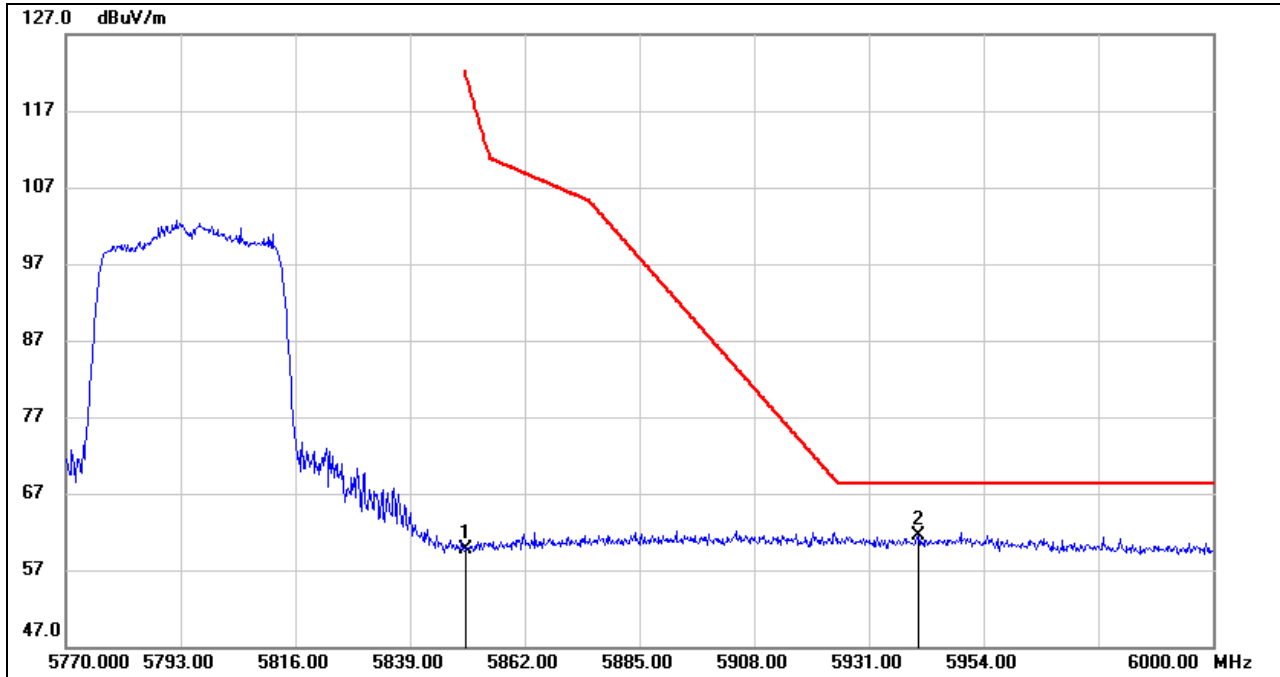

No.	Frequency (MHz)	Reading (dBuV)	Correct (dB/m)	Result (dBuV/m)	Limit (dBuV/m)	Margin (dB)	Remark
1	5850.000	16.74	42.89	59.63	122.20	-62.57	peak
2	5940.890	18.41	43.15	61.56	68.20	-6.64	peak

Note: 1. Measurement = Reading Level + Correct Factor.

HARMONICS AND SPURIOUS EMISSIONS LOW CHANNEL

HORIZONTAL RESULTS
1-7GHz

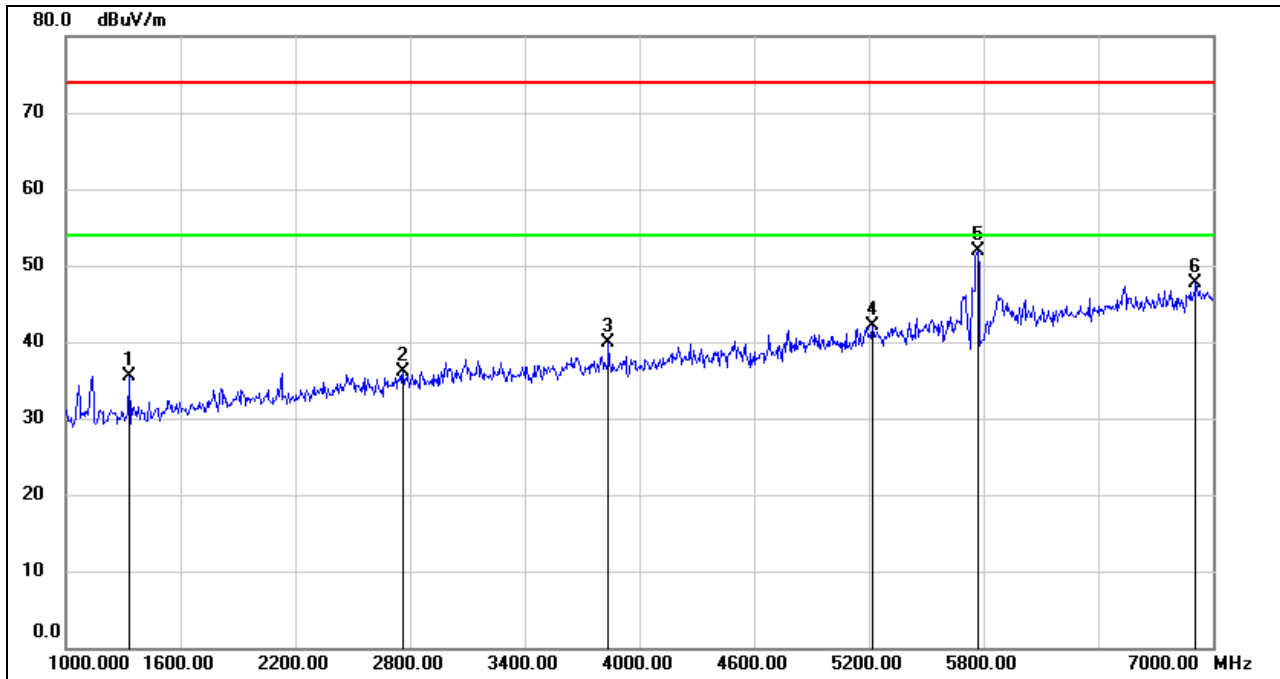

No.	Frequency (MHz)	Reading (dBuV)	Correct (dB/m)	Result (dBuV/m)	Limit (dBuV/m)	Margin (dB)	Remark
1	1330.000	48.77	-13.18	35.59	74.00	-38.41	peak
2	2764.000	43.52	-7.47	36.05	74.00	-37.95	peak
3	3838.000	44.08	-4.20	39.88	74.00	-34.12	peak
4	5218.000	41.21	0.93	42.14	74.00	-31.86	peak
5	5770.000	49.13	2.70	51.83	74.00	-22.17	peak
6	6910.000	41.42	6.31	47.73	74.00	-26.27	peak

Note: 1. Measurement = Reading Level + Correct Factor.
 2. If Peak Result complies with AV limit, AV Result is deemed to comply with AV limit.
 3. Peak: Peak detector.
 4. Filter losses were only considered in then spurious frequency bands and the authorized band was not corrected for BRF losses.
 5. Proper operation of the transmitter prior to adding the filter to the measurement chain.
 6. Owing to the highest peak level complies with the lowest limit of unwanted emission out of the restricted bands (Please refer to page 72), so all the test point were deemed to comply with the limits list in the standard.



HORIZONTAL RESULTS
7-18GHz

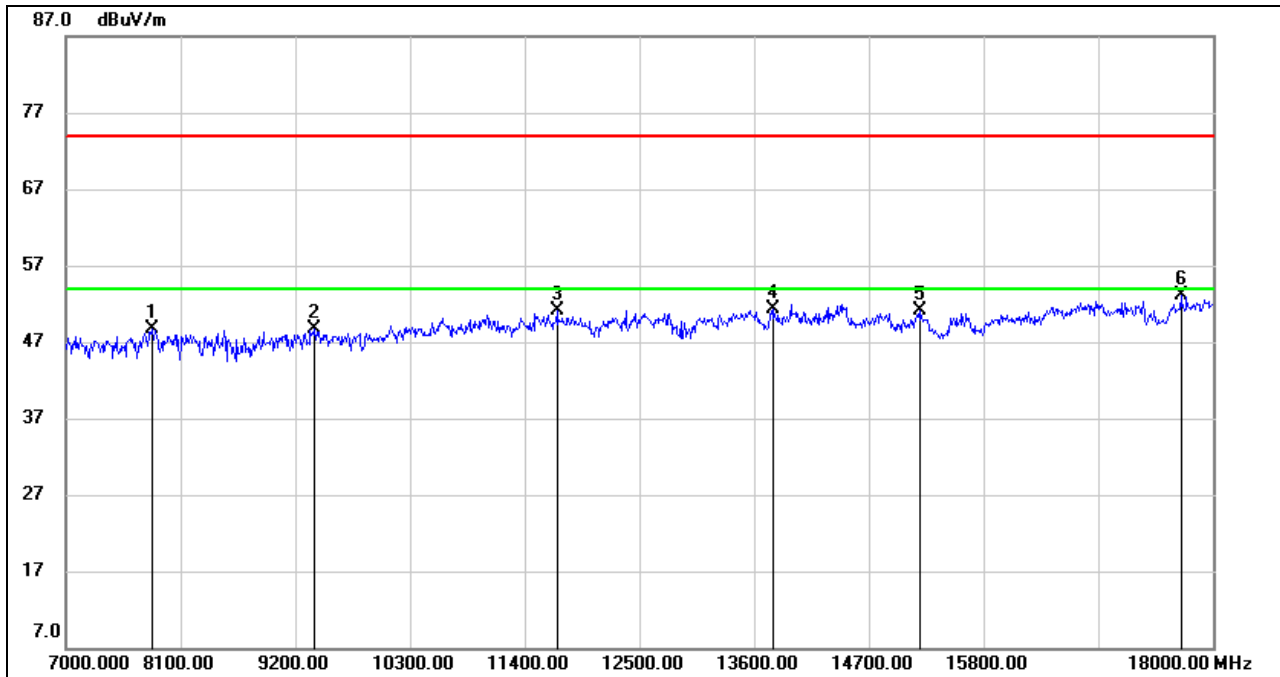

No.	Frequency (MHz)	Reading (dBuV)	Correct (dB/m)	Result (dBuV/m)	Limit (dBuV/m)	Margin (dB)	Remark
1	7825.000	39.17	9.53	48.70	74.00	-25.30	peak
2	9387.000	37.81	10.89	48.70	74.00	-25.30	peak
3	11708.000	36.89	14.17	51.06	74.00	-22.94	peak
4	13787.000	33.91	17.43	51.34	74.00	-22.66	peak
5	15195.000	35.04	16.06	51.10	74.00	-22.90	peak
6	17692.000	30.65	22.54	53.19	74.00	-20.81	peak

Note: 1. Measurement = Reading Level + Correct Factor.
 2. If Peak Result complies with AV limit, AV Result is deemed to comply with AV limit.
 3. Peak: Peak detector.
 4. Filter losses were only considered in the spurious frequency bands and the authorized band was not corrected for HPF losses.
 5. Proper operation of the transmitter prior to adding the filter to the measurement chain.
 6. Owing to the highest peak level complies with the lowest limit of unwanted emission out of the restricted bands (Please refer to page 72), so all the test point were deemed to comply with the limits list in the standard.



VERTICAL RESULTS
1-7GHz

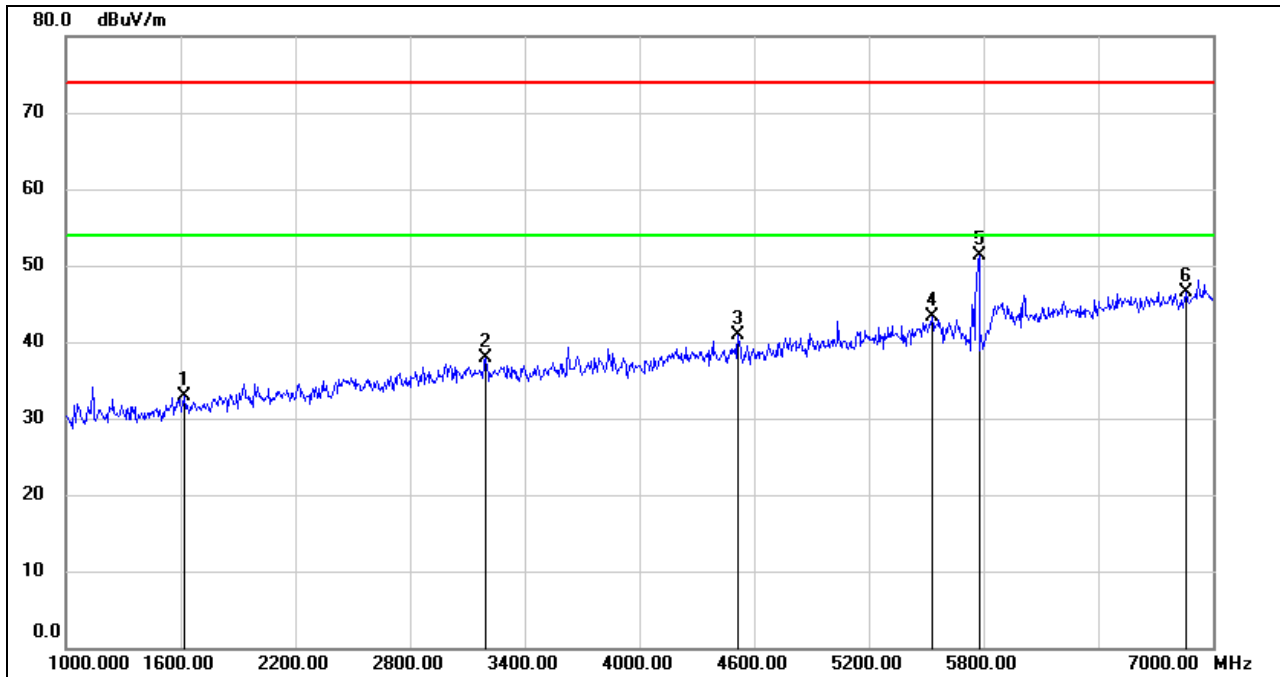

No.	Frequency (MHz)	Reading (dBuV)	Correct (dB/m)	Result (dBuV/m)	Limit (dBuV/m)	Margin (dB)	Remark
1	1618.000	45.09	-12.18	32.91	74.00	-41.09	peak
2	3196.000	43.90	-5.96	37.94	74.00	-36.06	peak
3	4516.000	42.94	-2.08	40.86	74.00	-33.14	peak
4	5530.000	41.10	2.27	43.37	74.00	-30.63	peak
5	5776.000	48.56	2.74	51.30	74.00	-22.70	peak
6	6862.000	40.52	6.03	46.55	74.00	-27.45	peak

Note: 1. Measurement = Reading Level + Correct Factor.
 2. If Peak Result complies with AV limit, AV Result is deemed to comply with AV limit.
 3. Peak: Peak detector.
 4. Filter losses were only considered in then spurious frequency bands and the authorized band was not corrected for BRF losses.
 5. Proper operation of the transmitter prior to adding the filter to the measurement chain.
 6. Owing to the highest peak level complies with the lowest limit of unwanted emission out of the restricted bands (Please refer to page 72), so all the test point were deemed to comply with the limits list in the standard.



7-18GHz

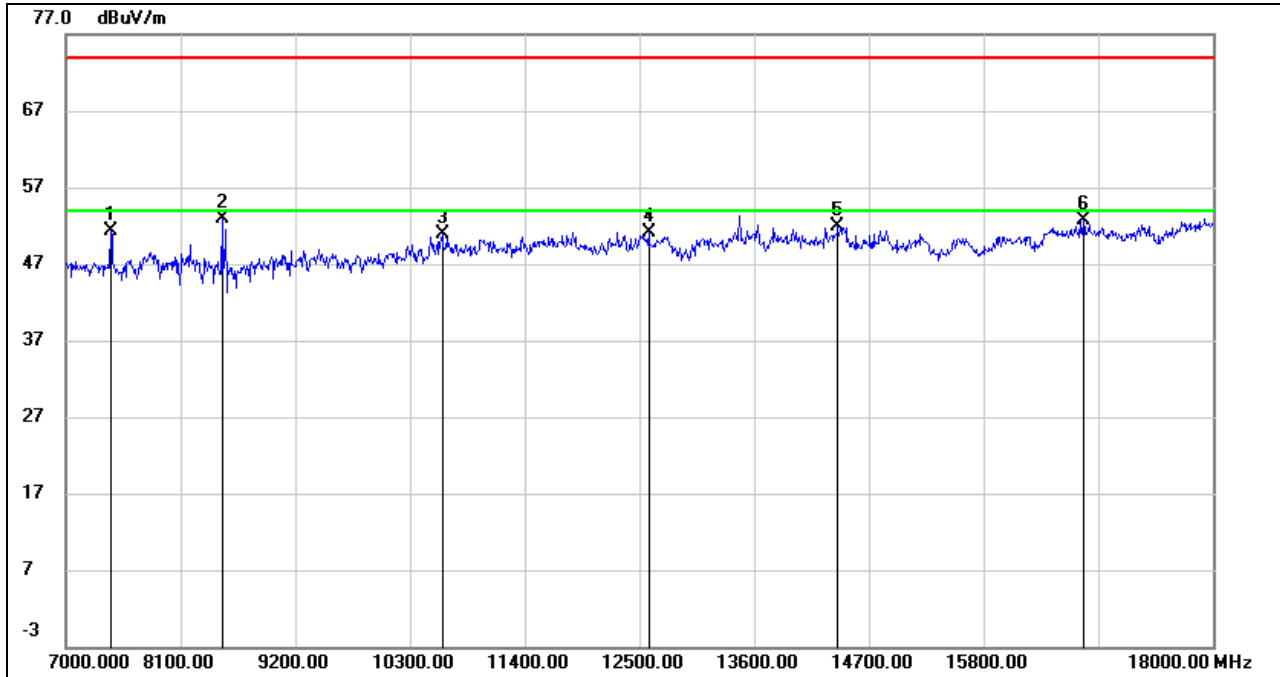

No.	Frequency (MHz)	Reading (dBuV)	Correct (dB/m)	Result (dBuV/m)	Limit (dBuV/m)	Margin (dB)	Remark
1	7429.000	43.06	8.28	51.34	74.00	-22.66	peak
2	8496.000	43.59	9.26	52.85	74.00	-21.15	peak
3	10608.000	37.65	13.34	50.99	74.00	-23.01	peak
4	12588.000	36.36	14.76	51.12	74.00	-22.88	peak
5	14403.000	34.99	17.01	52.00	74.00	-22.00	peak
6	16757.000	32.19	20.45	52.64	74.00	-21.36	peak

Note: 1. Measurement = Reading Level + Correct Factor.
 2. If Peak Result complies with AV limit, AV Result is deemed to comply with AV limit.
 3. Peak: Peak detector.
 4. Filter losses were only considered in the spurious frequency bands and the authorized band was not corrected for HPF losses.
 5. Proper operation of the transmitter prior to adding the filter to the measurement chain.
 6. Owing to the highest peak level complies with the lowest limit of unwanted emission out of the restricted bands (Please refer to page 72), so all the test point were deemed to comply with the limits list in the standard.

HARMONICS AND SPURIOUS EMISSIONS HIGH CHANNEL

HORIZONTAL RESULTS
1-7GHz

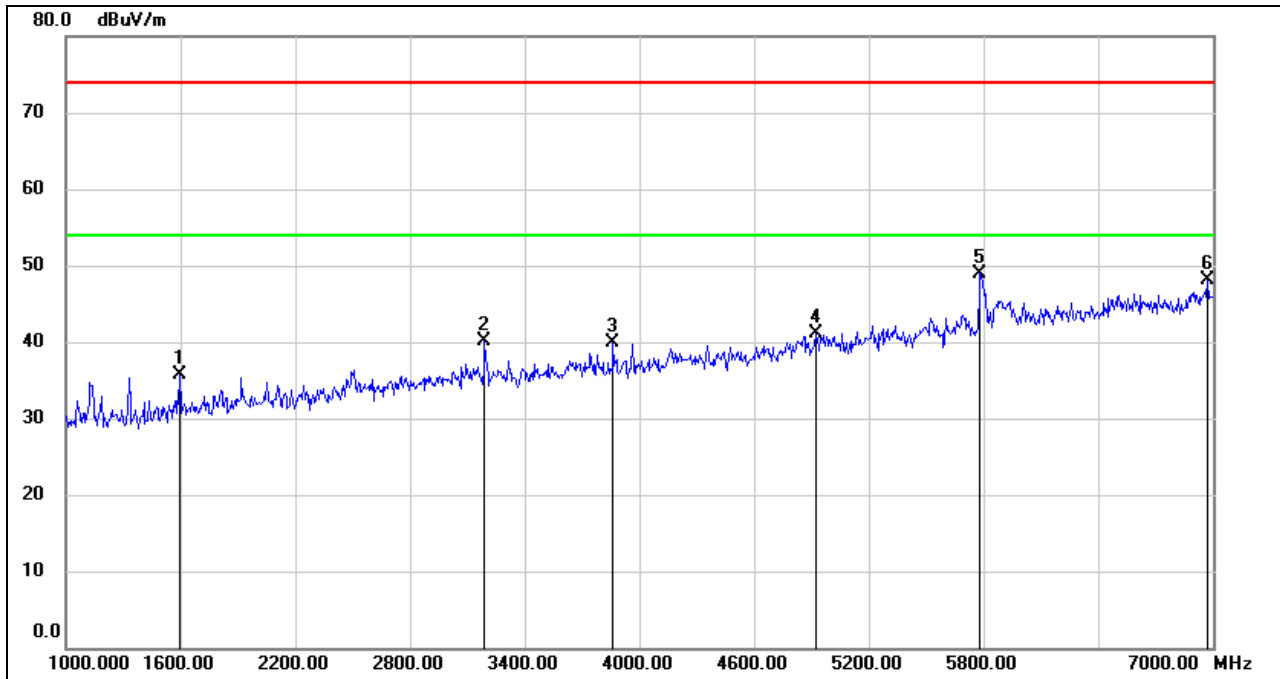

No.	Frequency (MHz)	Reading (dBuV)	Correct (dB/m)	Result (dBuV/m)	Limit (dBuV/m)	Margin (dB)	Remark
1	1594.000	47.89	-12.27	35.62	74.00	-38.38	peak
2	3190.000	46.04	-5.94	40.10	74.00	-33.90	peak
3	3862.000	44.16	-4.20	39.96	74.00	-34.04	peak
4	4924.000	41.73	-0.63	41.10	74.00	-32.90	peak
5	5782.000	46.22	2.78	49.00	74.00	-25.00	peak
6	6970.000	41.65	6.39	48.04	74.00	-25.96	peak

Note: 1. Measurement = Reading Level + Correct Factor.
 2. If Peak Result complies with AV limit, AV Result is deemed to comply with AV limit.
 3. Peak: Peak detector.
 4. Filter losses were only considered in then spurious frequency bands and the authorized band was not corrected for BRF losses.
 5. Proper operation of the transmitter prior to adding the filter to the measurement chain.
 6. Owing to the highest peak level complies with the lowest limit of unwanted emission out of the restricted bands (Please refer to page 72), so all the test point were deemed to comply with the limits list in the standard.



HORIZONTAL RESULTS
7-18GHz

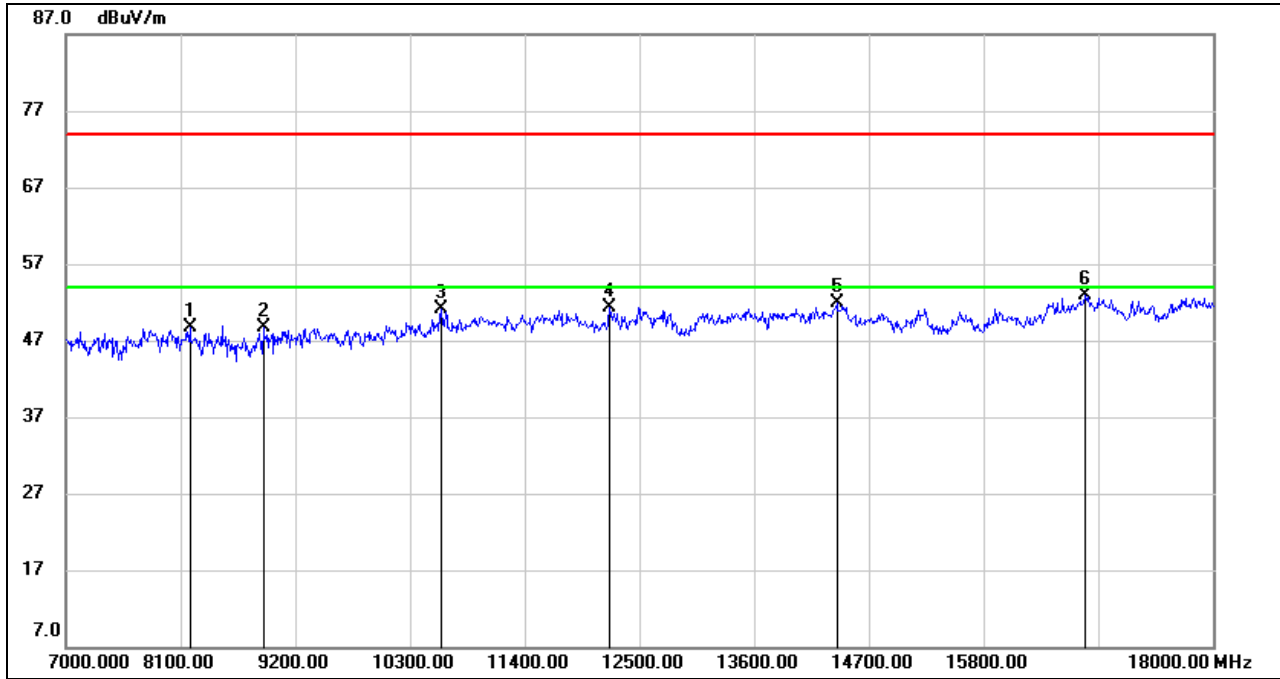

No.	Frequency (MHz)	Reading (dBuV)	Correct (dB/m)	Result (dBuV/m)	Limit (dBuV/m)	Margin (dB)	Remark
1	8188.000	38.47	10.23	48.70	74.00	-25.30	peak
2	8892.000	38.84	9.88	48.72	74.00	-25.28	peak
3	10597.000	37.75	13.38	51.13	74.00	-22.87	peak
4	12214.000	36.34	15.03	51.37	74.00	-22.63	peak
5	14392.000	34.86	16.99	51.85	74.00	-22.15	peak
6	16768.000	32.51	20.47	52.98	74.00	-21.02	peak

Note: 1. Measurement = Reading Level + Correct Factor.
 2. If Peak Result complies with AV limit, AV Result is deemed to comply with AV limit.
 3. Peak: Peak detector.
 4. Filter losses were only considered in the spurious frequency bands and the authorized band was not corrected for HPF losses.
 5. Proper operation of the transmitter prior to adding the filter to the measurement chain.
 6. Owing to the highest peak level complies with the lowest limit of unwanted emission out of the restricted bands (Please refer to page 72), so all the test point were deemed to comply with the limits list in the standard.



VERTICAL RESULTS 1-7GHz

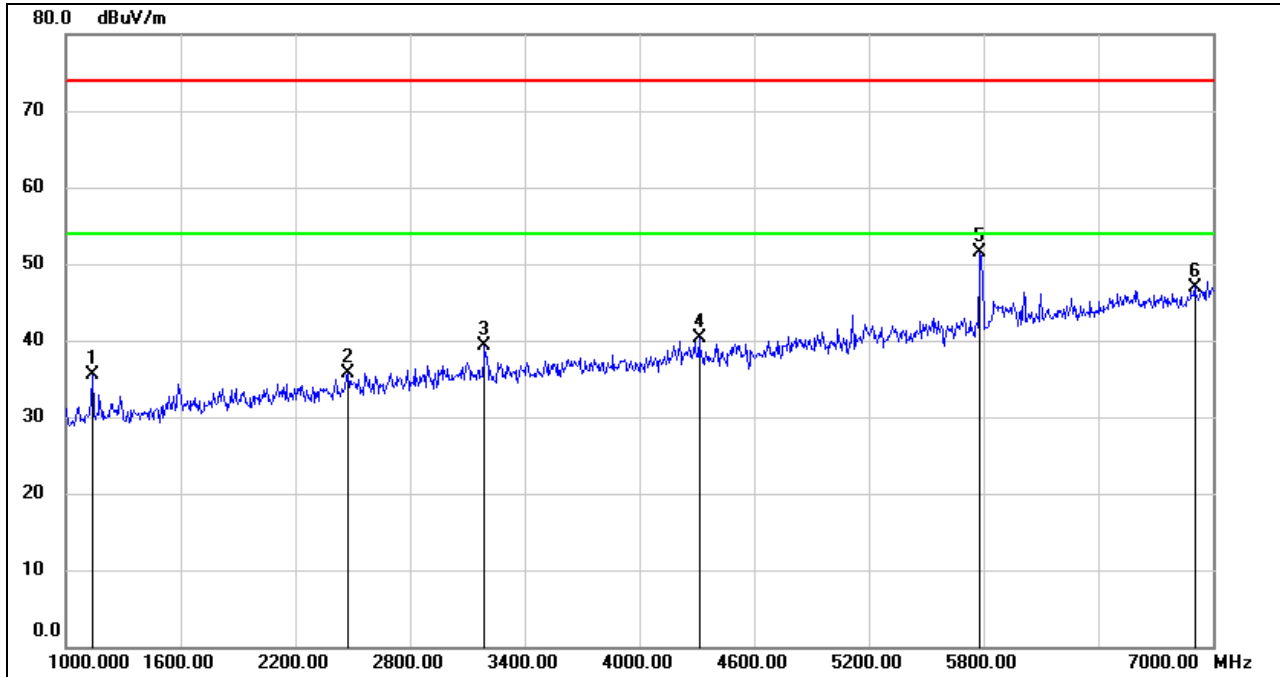

No.	Frequency (MHz)	Reading (dBuV)	Correct (dB/m)	Result (dBuV/m)	Limit (dBuV/m)	Margin (dB)	Remark
1	1138.000	49.63	-14.07	35.56	74.00	-38.44	peak
2	2476.000	44.13	-8.36	35.77	74.00	-38.23	peak
3	3190.000	45.28	-5.94	39.34	74.00	-34.66	peak
4	4312.000	43.61	-3.26	40.35	74.00	-33.65	peak
5	5782.000	48.75	2.78	51.53	74.00	-22.47	peak
6	6904.000	40.70	6.30	47.00	74.00	-27.00	peak

Note: 1. Measurement = Reading Level + Correct Factor.
2. If Peak Result complies with AV limit, AV Result is deemed to comply with AV limit.
3. Peak: Peak detector.
4. Filter losses were only considered in then spurious frequency bands and the authorized band was not corrected for BRF losses.
5. Proper operation of the transmitter prior to adding the filter to the measurement chain.
6. Owing to the highest peak level complies with the lowest limit of unwanted emission out of the restricted bands (Please refer to page 72), so all the test point were deemed to comply with the limits list in the standard.

7-18GHz

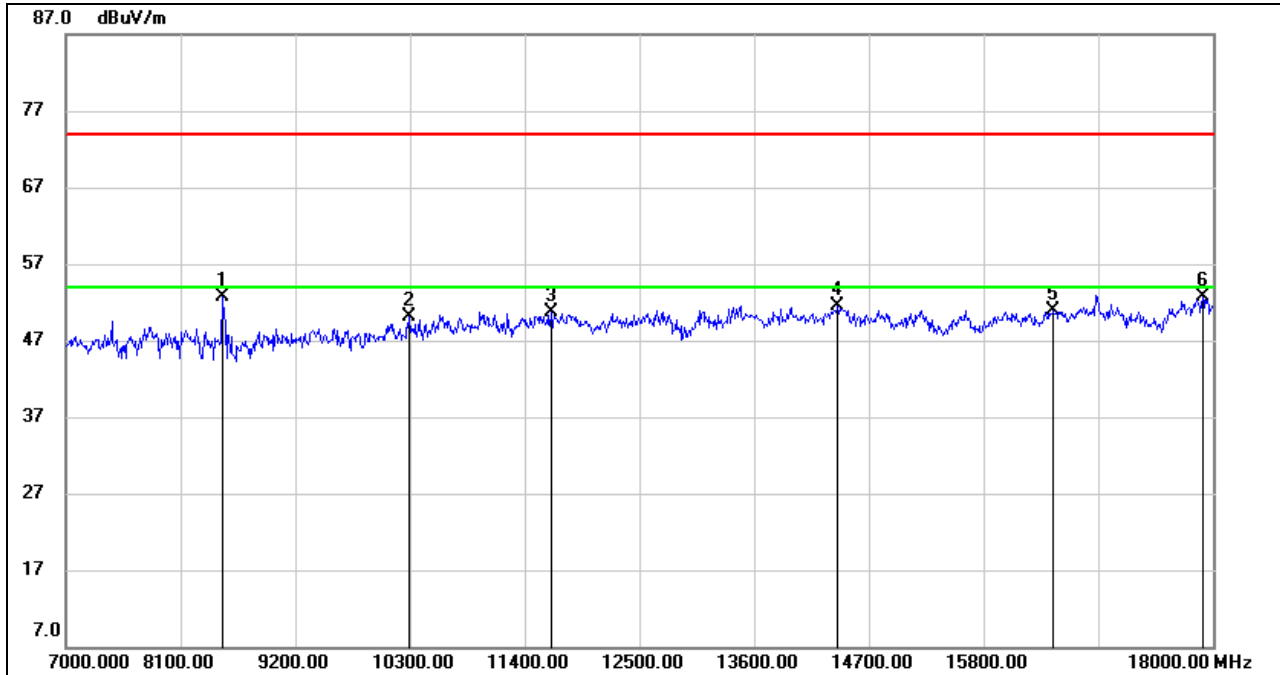

No.	Frequency (MHz)	Reading (dBuV)	Correct (dB/m)	Result (dBuV/m)	Limit (dBuV/m)	Margin (dB)	Remark
1	8496.000	43.53	9.26	52.79	74.00	-21.21	peak
2	10289.000	38.06	12.10	50.16	74.00	-23.84	peak
3	11653.000	36.32	14.38	50.70	74.00	-23.30	peak
4	14403.000	34.54	17.01	51.55	74.00	-22.45	peak
5	16471.000	31.26	19.69	50.95	74.00	-23.05	peak
6	17901.000	29.37	23.39	52.76	74.00	-21.24	peak

Note: 1. Measurement = Reading Level + Correct Factor.
 2. If Peak Result complies with AV limit, AV Result is deemed to comply with AV limit.
 3. Peak: Peak detector.
 4. Filter losses were only considered in the spurious frequency bands and the authorized band was not corrected for HPF losses.
 5. Proper operation of the transmitter prior to adding the filter to the measurement chain.
 6. Owing to the highest peak level complies with the lowest limit of unwanted emission out of the restricted bands (Please refer to page 72), so all the test point were deemed to comply with the limits list in the standard.

7.4. 802.11ac VHT80 MODE

SISO MODE (WORST-CASE CONFIGURATION)

7.4.1. UNII-1 BAND

RESTRICTED BANDEDGE LOW CHANNEL

HORIZONTAL RESULTS PEAK

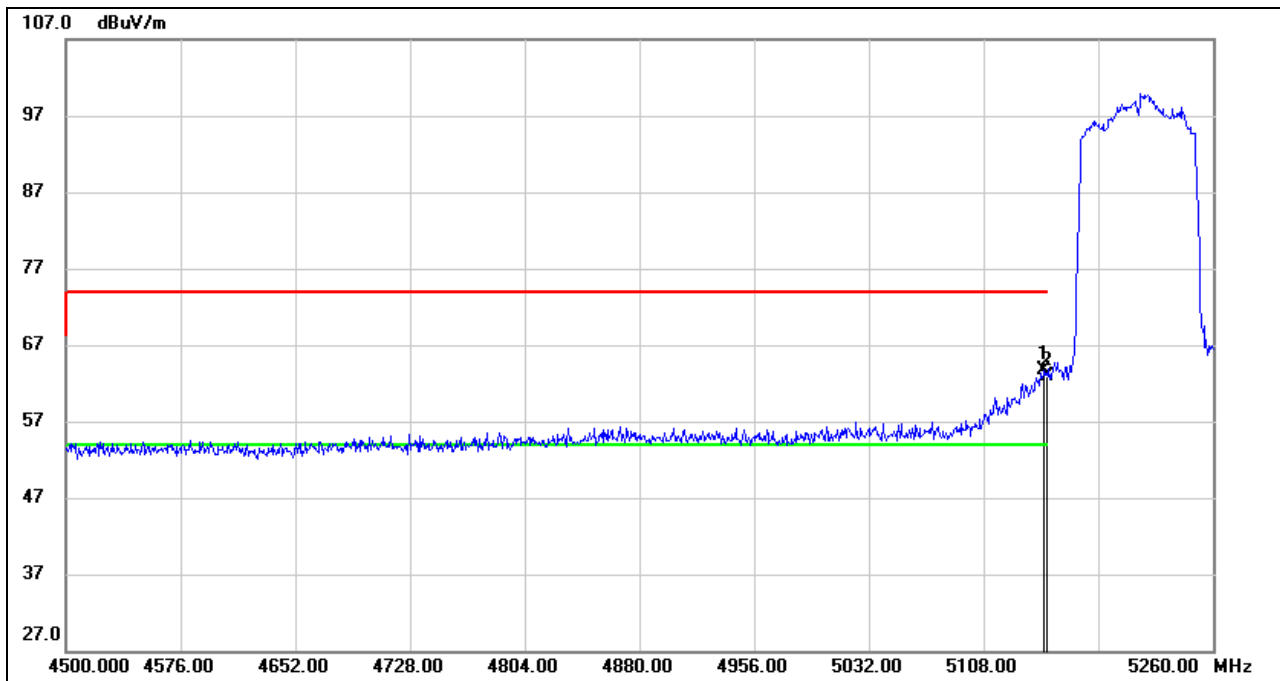

No.	Frequency (MHz)	Reading (dBuV)	Correct (dB/m)	Result (dBuV/m)	Limit (dBuV/m)	Margin (dB)	Remark
1	5148.280	23.26	40.46	63.72	74.00	-10.28	peak
2	5150.000	22.51	40.46	62.97	74.00	-11.03	peak

- Note:
1. Measurement = Reading Level + Correct Factor.
 2. If Peak Result complies with AV limit, AV Result is deemed to comply with AV limit.
 3. Peak: Peak detector.
 4. Only the worst case emission will be recorded, if it complies with the limit, the other emissions deemed to comply with the limit.



AVG

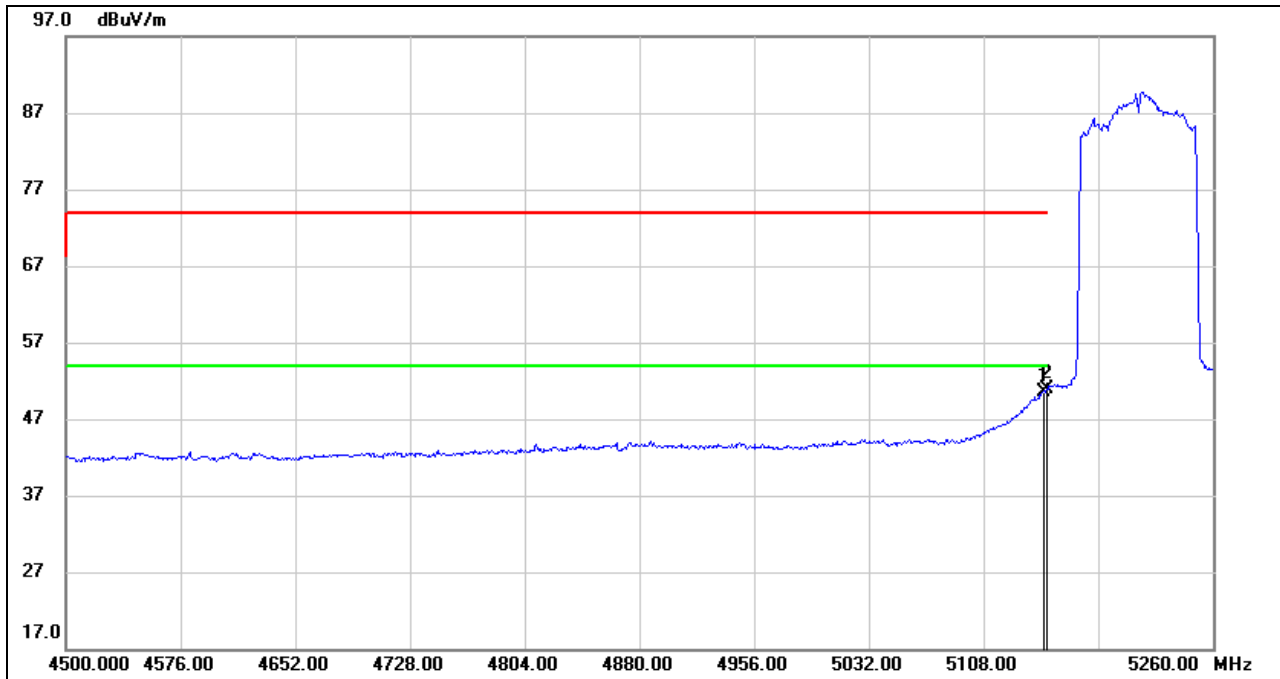

No.	Frequency (MHz)	Reading (dBuV)	Correct (dB/m)	Result (dBuV/m)	Limit (dBuV/m)	Margin (dB)	Remark
1	5148.280	10.14	40.46	50.60	54.00	-3.40	AVG
2	5150.000	10.48	40.46	50.94	54.00	-3.06	AVG

Note: 1. Measurement = Reading Level + Correct Factor.
 2. AVG: $VBW=1/T_{on}$ where: t_{on} is transmit duration.
 3. For duty cycle, please refer to clause 6.1.
 4. Only the worst case emission will be recorded, if it complies with the limit, the other emissions deemed to comply with the limit.



VERTICAL RESULTS PEAK

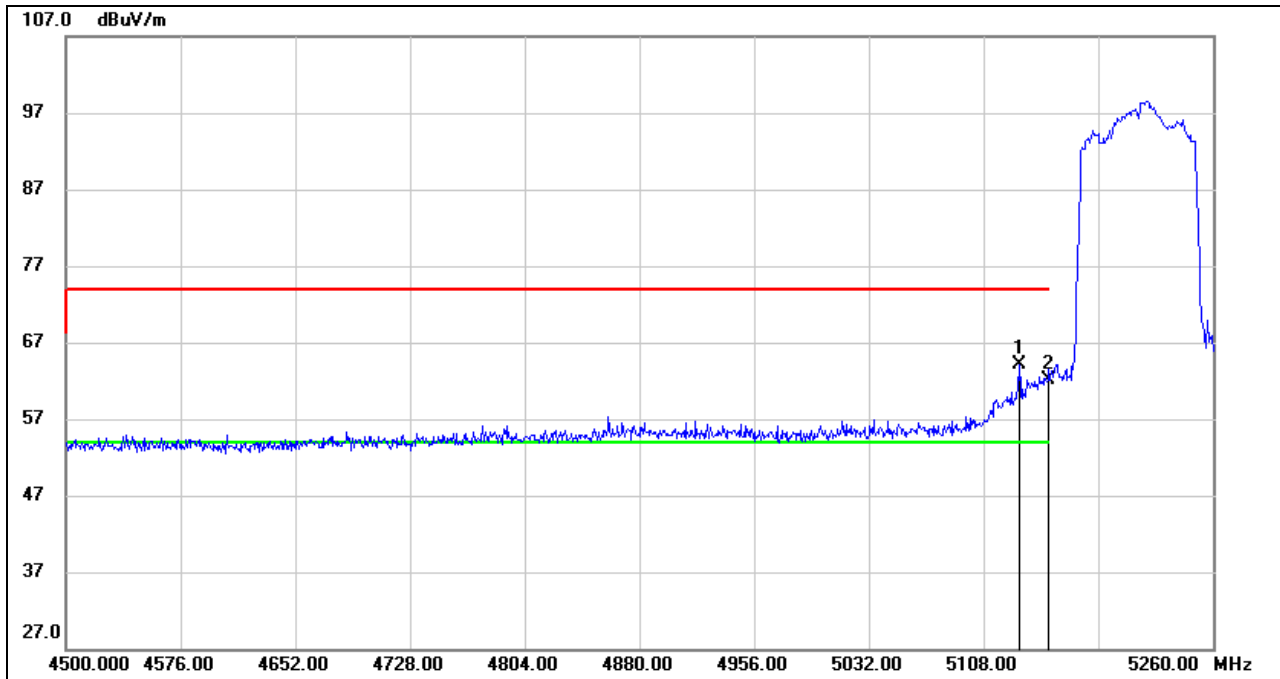

No.	Frequency (MHz)	Reading (dBuV)	Correct (dB/m)	Result (dBuV/m)	Limit (dBuV/m)	Margin (dB)	Remark
1	5131.560	23.83	40.36	64.19	74.00	-9.81	peak
2	5150.000	21.68	40.46	62.14	74.00	-11.86	peak

Note: 1. Measurement = Reading Level + Correct Factor.
2. If Peak Result complies with AV limit, AV Result is deemed to comply with AV limit.
3. Peak: Peak detector.
4. Only the worst case emission will be recorded, if it complies with the limit, the other emissions deemed to comply with the limit.



AVG

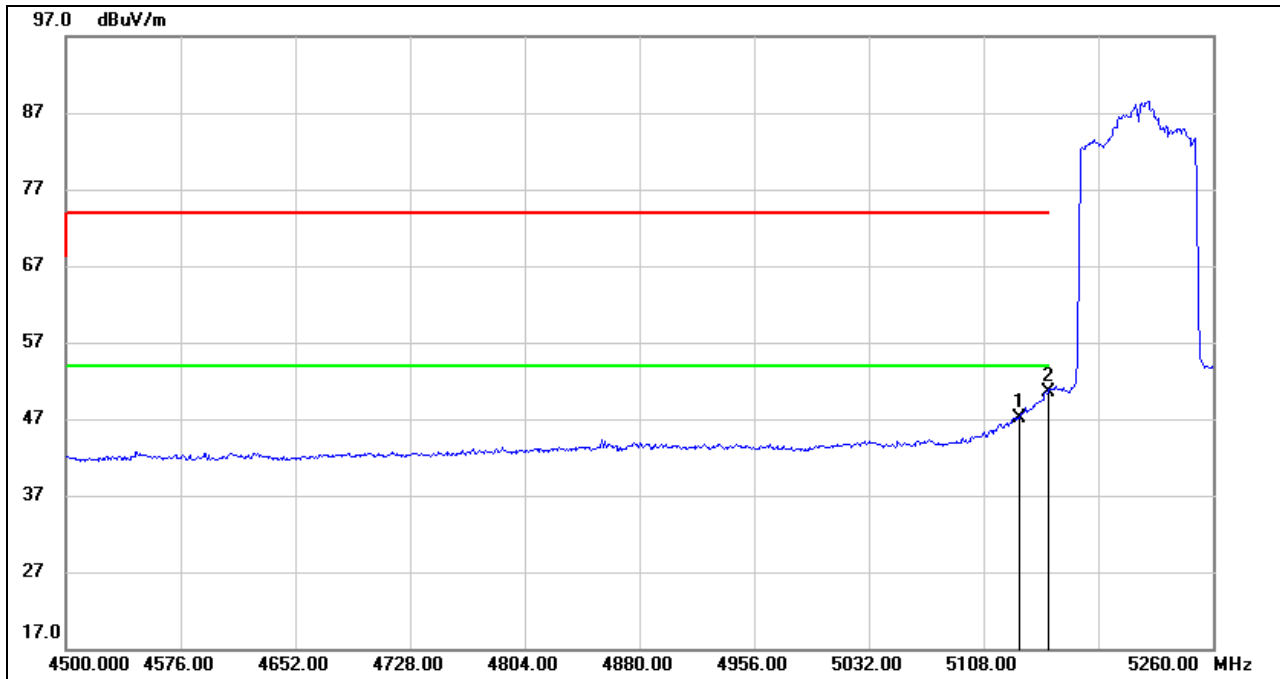

No.	Frequency (MHz)	Reading (dBuV)	Correct (dB/m)	Result (dBuV/m)	Limit (dBuV/m)	Margin (dB)	Remark
1	5131.560	6.82	40.36	47.18	54.00	-6.82	AVG
2	5150.000	10.08	40.46	50.54	54.00	-3.46	AVG

Note: 1. Measurement = Reading Level + Correct Factor.
 2. AVG: $VBW=1/T_{on}$ where: t_{on} is transmit duration.
 3. For duty cycle, please refer to clause 6.1.
 4. Only the worst case emission will be recorded, if it complies with the limit, the other emissions deemed to comply with the limit.



HARMONICS AND SPURIOUS EMISSIONS LOW CHANNEL

HORIZONTAL RESULTS
1-7GHz

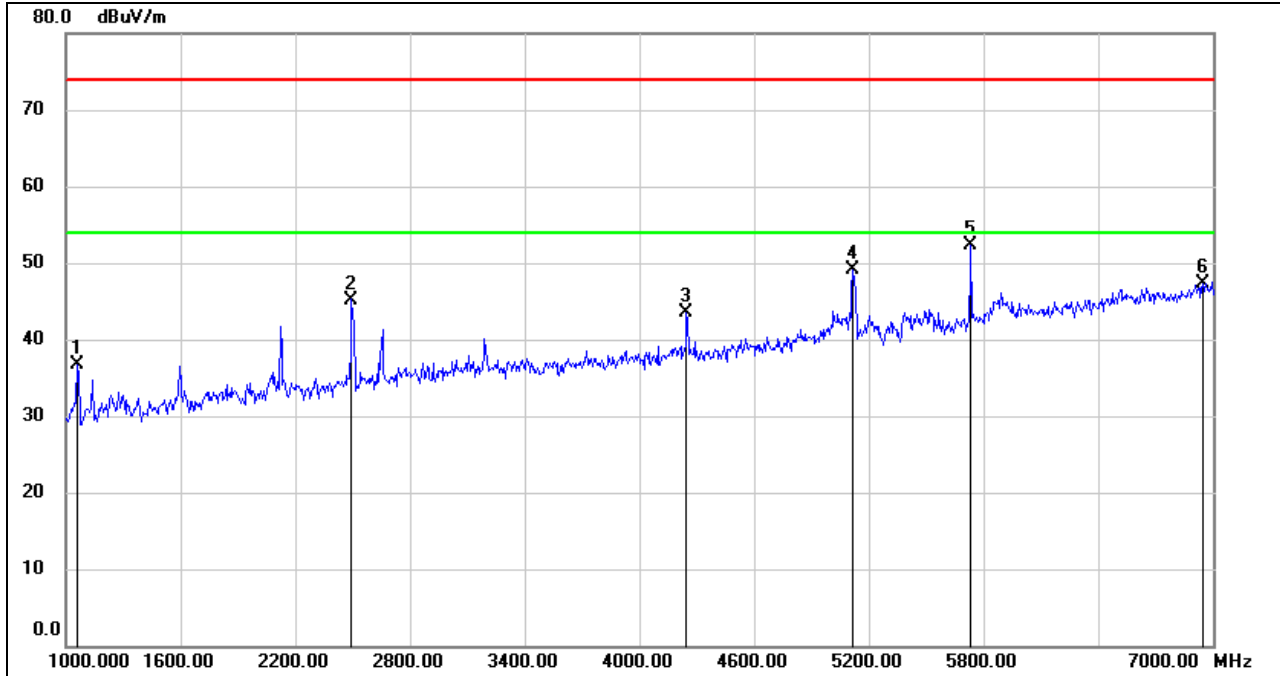

No.	Frequency (MHz)	Reading (dBuV)	Correct (dB/m)	Result (dBuV/m)	Limit (dBuV/m)	Margin (dB)	Remark
1	1060.000	51.18	-14.51	36.67	74.00	-37.33	peak
2	2494.000	53.41	-8.21	45.20	74.00	-28.80	peak
3	4246.000	46.62	-3.03	43.59	74.00	-30.41	peak
4	5116.000	48.82	0.26	49.08	74.00	-24.92	peak
5	5734.000	49.88	2.45	52.33	74.00	-21.67	peak
6	6946.000	41.00	6.34	47.34	74.00	-26.66	peak

Note: 1. Measurement = Reading Level + Correct Factor.
 2. If Peak Result complies with AV limit, AV Result is deemed to comply with AV limit.
 3. Peak: Peak detector.
 4. Filter losses were only considered in then spurious frequency bands and the authorized band was not corrected for BRF losses.
 5. Proper operation of the transmitter prior to adding the filter to the measurement chain.
 6. Owing to the highest peak level complies with the lowest limit of unwanted emission out of the restricted bands (Please refer to page 72), so all the test point were deemed to comply with the limits list in the standard.



HORIZONTAL RESULTS
7-18GHz

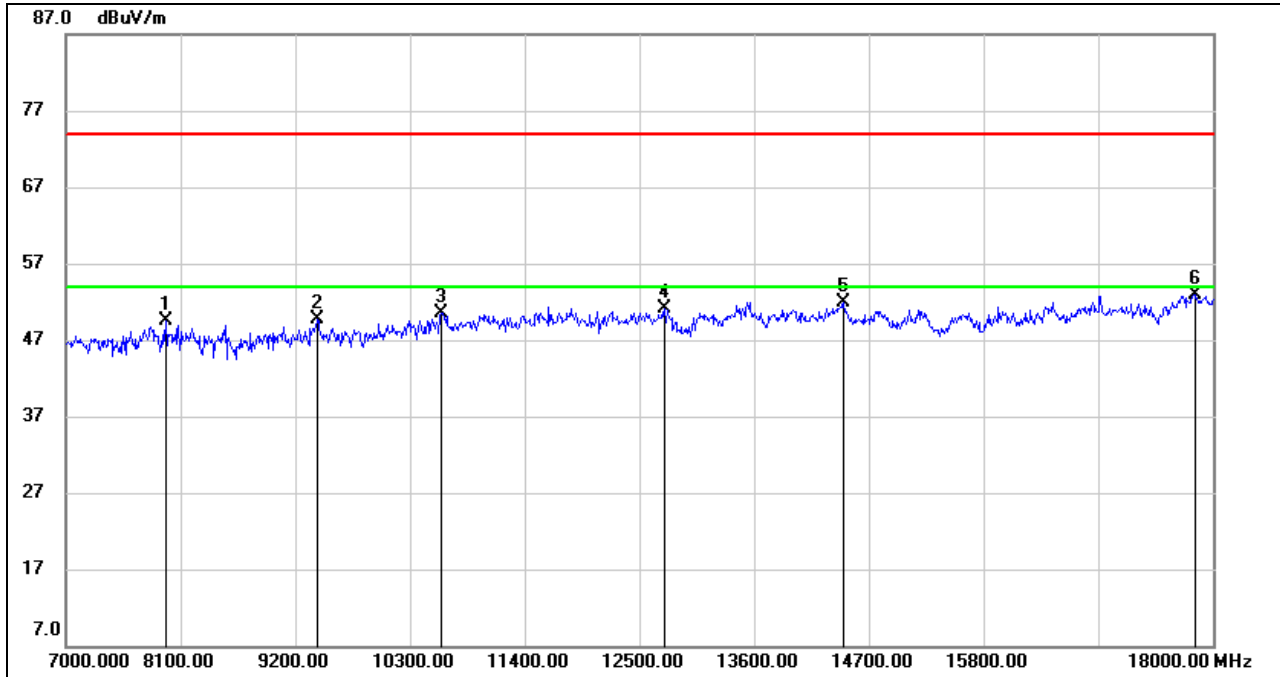

No.	Frequency (MHz)	Reading (dBuV)	Correct (dB/m)	Result (dBuV/m)	Limit (dBuV/m)	Margin (dB)	Remark
1	7957.000	40.47	9.04	49.51	74.00	-24.49	peak
2	9409.000	38.79	10.95	49.74	74.00	-24.26	peak
3	10597.000	37.12	13.38	50.50	74.00	-23.50	peak
4	12742.000	35.66	15.48	51.14	74.00	-22.86	peak
5	14458.000	34.98	16.91	51.89	74.00	-22.11	peak
6	17824.000	29.48	23.45	52.93	74.00	-21.07	peak

Note: 1. Measurement = Reading Level + Correct Factor.
 2. If Peak Result complies with AV limit, AV Result is deemed to comply with AV limit.
 3. Peak: Peak detector.
 4. Filter losses were only considered in the spurious frequency bands and the authorized band was not corrected for HPF losses.
 5. Proper operation of the transmitter prior to adding the filter to the measurement chain.
 6. Owing to the highest peak level complies with the lowest limit of unwanted emission out of the restricted bands (Please refer to page 72), so all the test point were deemed to comply with the limits list in the standard.



VERTICAL RESULTS
1-7GHz

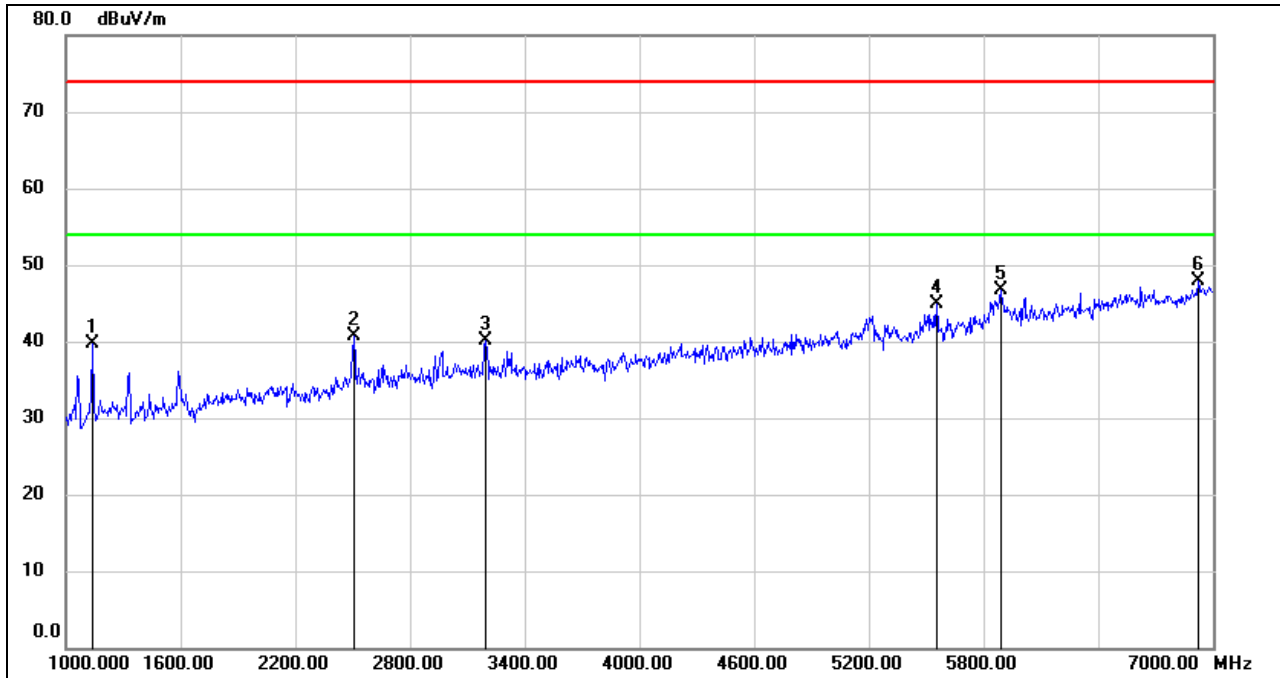

No.	Frequency (MHz)	Reading (dBuV)	Correct (dB/m)	Result (dBuV/m)	Limit (dBuV/m)	Margin (dB)	Remark
1	1138.000	53.86	-14.07	39.79	74.00	-34.21	peak
2	2506.000	48.86	-8.18	40.68	74.00	-33.32	peak
3	3196.000	46.13	-5.96	40.17	74.00	-33.83	peak
4	5554.000	42.76	2.21	44.97	74.00	-29.03	peak
5	5890.000	42.11	4.68	46.79	74.00	-27.21	peak
6	6922.000	41.52	6.32	47.84	74.00	-26.16	peak

Note: 1. Measurement = Reading Level + Correct Factor.
 2. If Peak Result complies with AV limit, AV Result is deemed to comply with AV limit.
 3. Peak: Peak detector.
 4. Filter losses were only considered in then spurious frequency bands and the authorized band was not corrected for BRF losses.
 5. Proper operation of the transmitter prior to adding the filter to the measurement chain.
 6. Owing to the highest peak level complies with the lowest limit of unwanted emission out of the restricted bands (Please refer to page 72), so all the test point were deemed to comply with the limits list in the standard.

7-18GHz

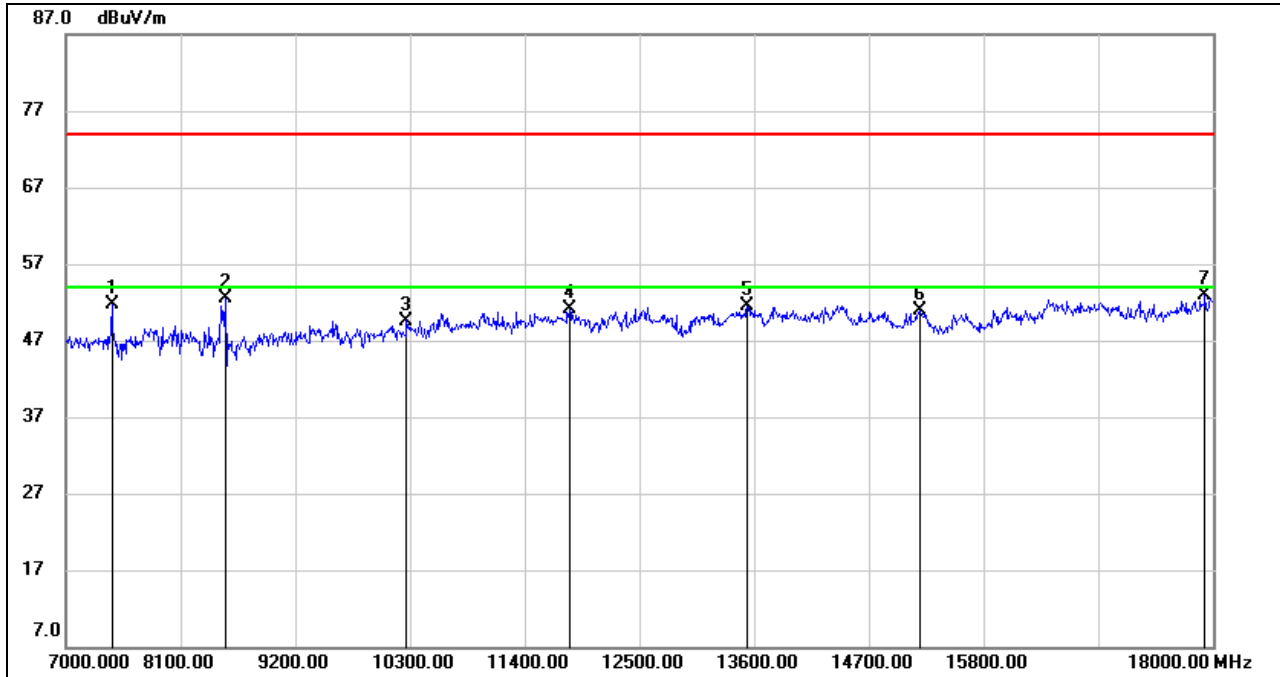

No.	Frequency (MHz)	Reading (dBuV)	Correct (dB/m)	Result (dBuV/m)	Limit (dBuV/m)	Margin (dB)	Remark
1	7440.000	43.50	8.23	51.73	74.00	-22.27	peak
2	8529.000	43.41	9.18	52.59	74.00	-21.41	peak
3	10267.000	37.70	11.90	49.60	74.00	-24.40	peak
4	11829.000	36.61	14.42	51.03	74.00	-22.97	peak
5	13534.000	35.28	16.31	51.59	74.00	-22.41	peak
6	15195.000	34.77	16.06	50.83	74.00	-23.17	peak
7	17923.000	29.48	23.40	52.88	74.00	-21.12	peak

Note: 1. Measurement = Reading Level + Correct Factor.
 2. If Peak Result complies with AV limit, AV Result is deemed to comply with AV limit.
 3. Peak: Peak detector.
 4. Filter losses were only considered in the spurious frequency bands and the authorized band was not corrected for HPF losses.
 5. Proper operation of the transmitter prior to adding the filter to the measurement chain.
 6. Owing to the highest peak level complies with the lowest limit of unwanted emission out of the restricted bands (Please refer to page 72), so all the test point were deemed to comply with the limits list in the standard.



7.4.2. UNII-2A BAND

RESTRICTED BANDEDGE LOW CHANNEL

HORIZONTAL RESULTS
PEAK

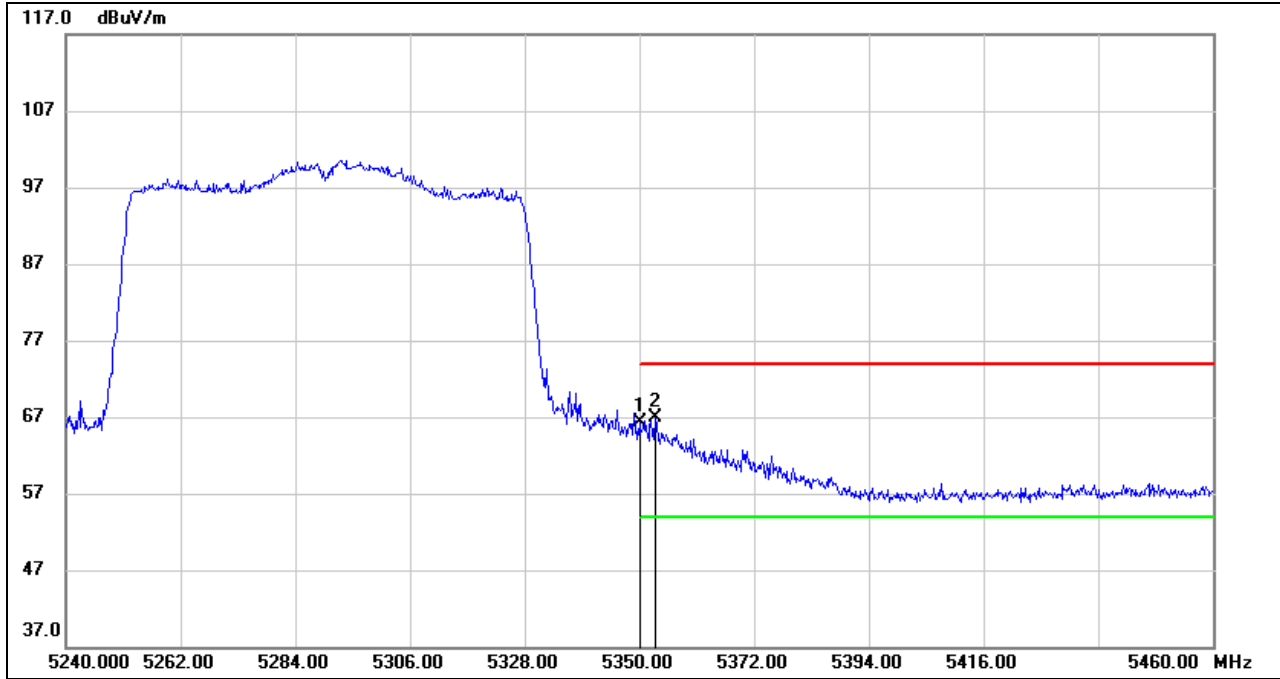

No.	Frequency (MHz)	Reading (dBuV)	Correct (dB/m)	Result (dBuV/m)	Limit (dBuV/m)	Margin (dB)	Remark
1	5350.000	25.70	40.64	66.34	74.00	-7.66	peak
2	5353.080	26.23	40.63	66.86	74.00	-7.14	peak

- Note: 1. Measurement = Reading Level + Correct Factor.
 2. If Peak Result complies with AV limit, AV Result is deemed to comply with AV limit.
 3. Peak: Peak detector.
 4. Only the worst case emission will be recorded, if it complies with the limit, the other emissions deemed to comply with the limit.



AVG

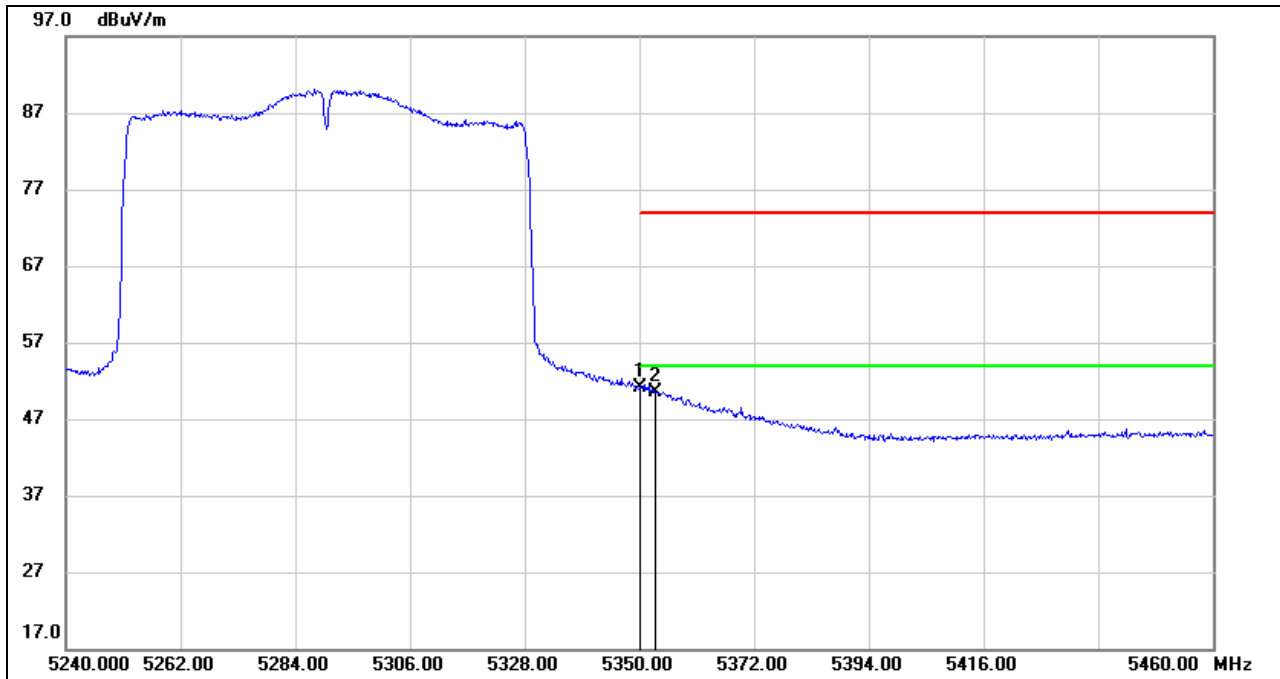

No.	Frequency (MHz)	Reading (dBuV)	Correct (dB/m)	Result (dBuV/m)	Limit (dBuV/m)	Margin (dB)	Remark
1	5350.000	10.47	40.64	51.11	54.00	-2.89	AVG
2	5353.080	9.87	40.63	50.50	54.00	-3.50	AVG

Note: 1. Measurement = Reading Level + Correct Factor
 2. AVG: $VBW=1/T_{on}$ where: t_{on} is transmit duration.
 3. For duty cycle, please refer to clause 6.1.
 4. Only the worst case emission will be recorded, if it complies with the limit, the other emissions deemed to comply with the limit.



VERTICAL RESULTS
PEAK

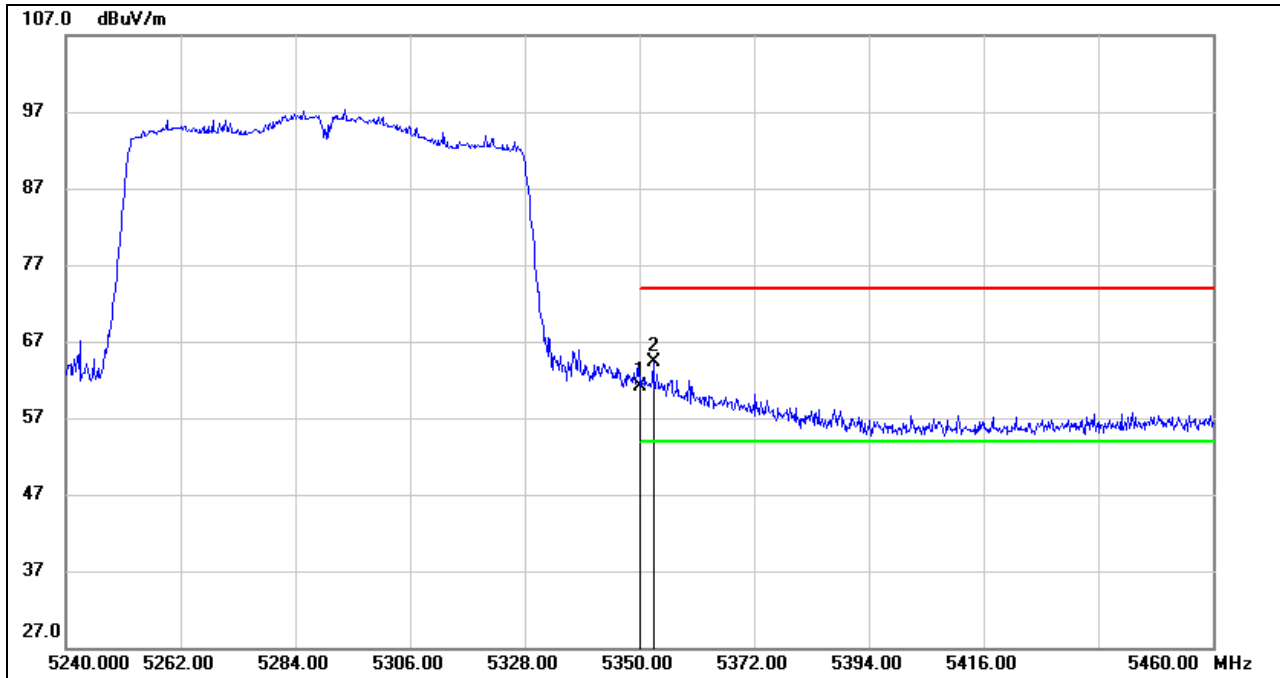

No.	Frequency (MHz)	Reading (dBuV)	Correct (dB/m)	Result (dBuV/m)	Limit (dBuV/m)	Margin (dB)	Remark
1	5350.000	20.37	40.64	61.01	74.00	-12.99	peak
2	5352.640	23.61	40.63	64.24	74.00	-9.76	peak

Note: 1. Measurement = Reading Level + Correct Factor.
2. If Peak Result complies with AV limit, AV Result is deemed to comply with AV limit.
3. Peak: Peak detector.
4. Only the worst case emission will be recorded, if it complies with the limit, the other emissions deemed to comply with the limit.



AVG

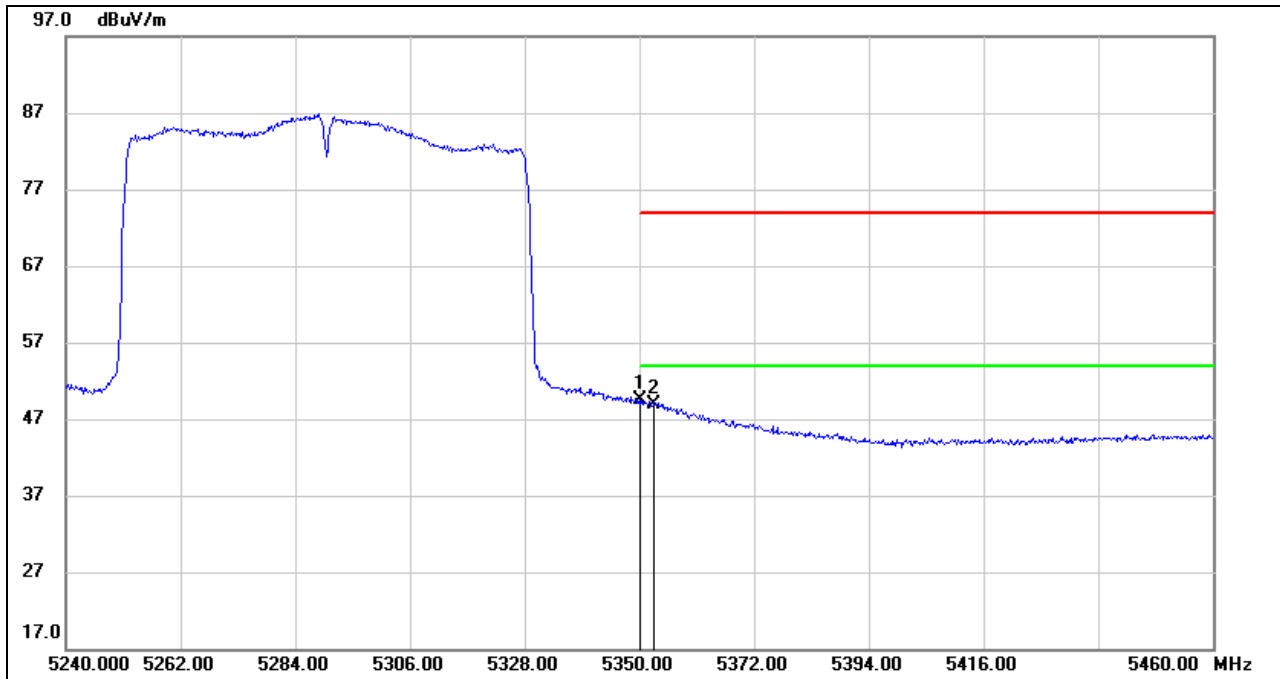

No.	Frequency (MHz)	Reading (dBuV)	Correct (dB/m)	Result (dBuV/m)	Limit (dBuV/m)	Margin (dB)	Remark
1	5350.000	8.80	40.64	49.44	54.00	-4.56	AVG
2	5352.640	8.24	40.63	48.87	54.00	-5.13	AVG

Note: 1. Measurement = Reading Level + Correct Factor
 2. AVG: $VBW=1/Ton$ where: ton is transmit duration.
 3. For duty cycle, please refer to clause 6.1.
 4. Only the worst case emission will be recorded, if it complies with the limit, the other emissions deemed to comply with the limit.



HARMONICS AND SPURIOUS EMISSIONS LOW CHANNEL

HORIZONTAL RESULTS
1-7GHz

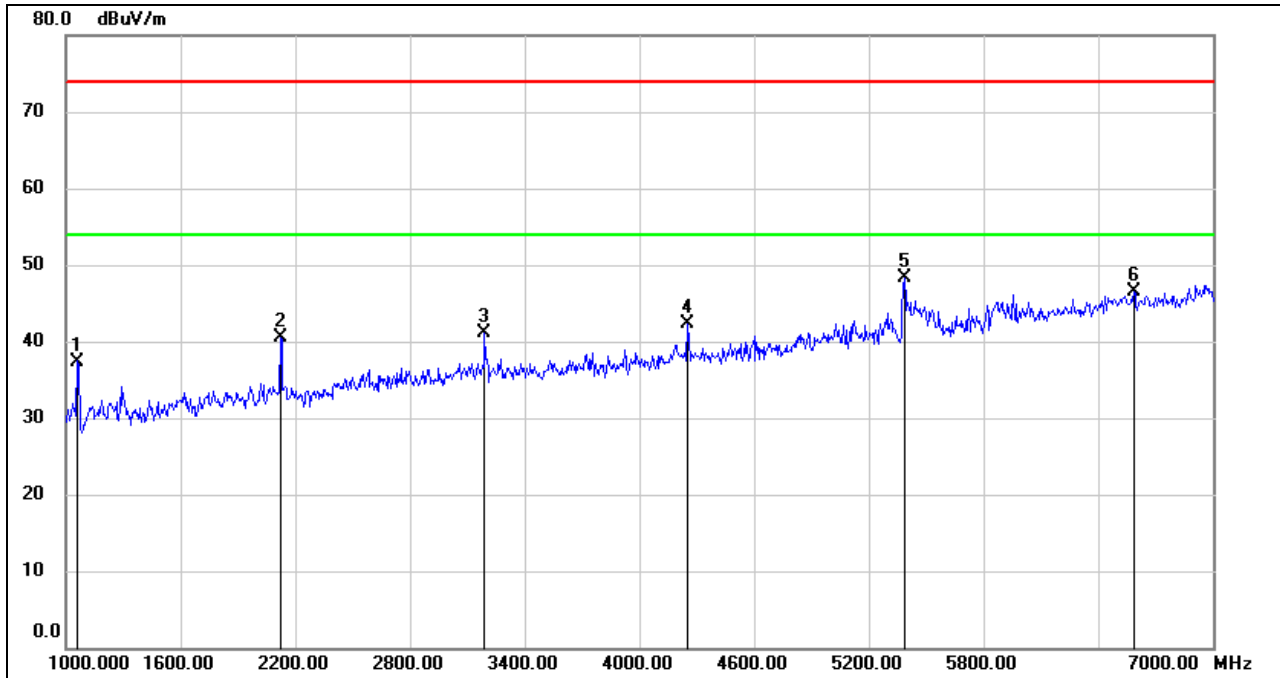

No.	Frequency (MHz)	Reading (dBuV)	Correct (dB/m)	Result (dBuV/m)	Limit (dBuV/m)	Margin (dB)	Remark
1	1060.000	51.91	-14.51	37.40	74.00	-36.60	peak
2	2122.000	50.65	-10.11	40.54	74.00	-33.46	peak
3	3190.000	47.11	-5.94	41.17	74.00	-32.83	peak
4	4252.000	45.37	-3.05	42.32	74.00	-31.68	peak
5	5386.000	47.44	0.88	48.32	74.00	-25.68	peak
6	6586.000	40.87	5.57	46.44	74.00	-27.56	peak

Note: 1. Measurement = Reading Level + Correct Factor.
 2. If Peak Result complies with AV limit, AV Result is deemed to comply with AV limit.
 3. Peak: Peak detector.
 4. Filter losses were only considered in then spurious frequency bands and the authorized band was not corrected for BRF losses.
 5. Proper operation of the transmitter prior to adding the filter to the measurement chain.
 6. Owing to the highest peak level complies with the lowest limit of unwanted emission out of the restricted bands (Please refer to page 72), so all the test point were deemed to comply with the limits list in the standard.



HORIZONTAL RESULTS
7-18GHz

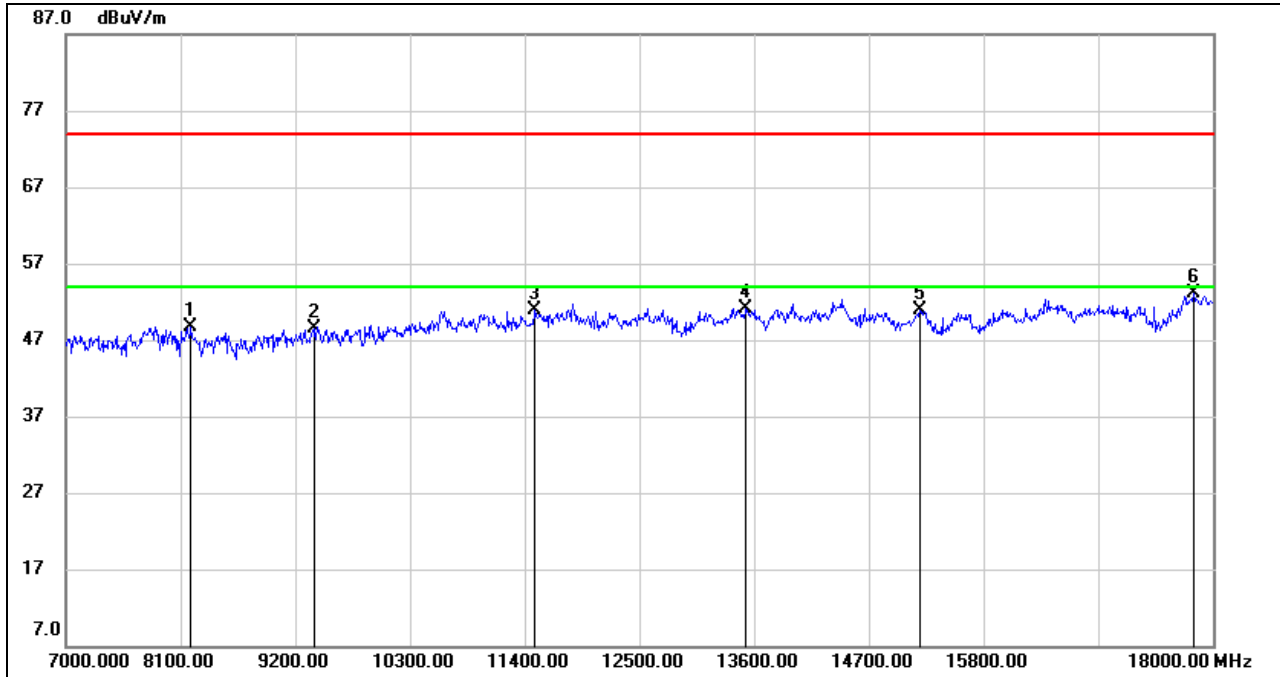

No.	Frequency (MHz)	Reading (dBuV)	Correct (dB/m)	Result (dBuV/m)	Limit (dBuV/m)	Margin (dB)	Remark
1	8199.000	38.34	10.31	48.65	74.00	-25.35	peak
2	9376.000	37.60	10.83	48.43	74.00	-25.57	peak
3	11499.000	36.47	14.43	50.90	74.00	-23.10	peak
4	13523.000	34.85	16.28	51.13	74.00	-22.87	peak
5	15184.000	34.79	16.05	50.84	74.00	-23.16	peak
6	17813.000	29.61	23.45	53.06	74.00	-20.94	peak

Note: 1. Measurement = Reading Level + Correct Factor.
 2. If Peak Result complies with AV limit, AV Result is deemed to comply with AV limit.
 3. Peak: Peak detector.
 4. Filter losses were only considered in the spurious frequency bands and the authorized band was not corrected for HPF losses.
 5. Proper operation of the transmitter prior to adding the filter to the measurement chain.
 6. Owing to the highest peak level complies with the lowest limit of unwanted emission out of the restricted bands (Please refer to page 72), so all the test point were deemed to comply with the limits list in the standard.



VERTICAL RESULTS
1-7GHz

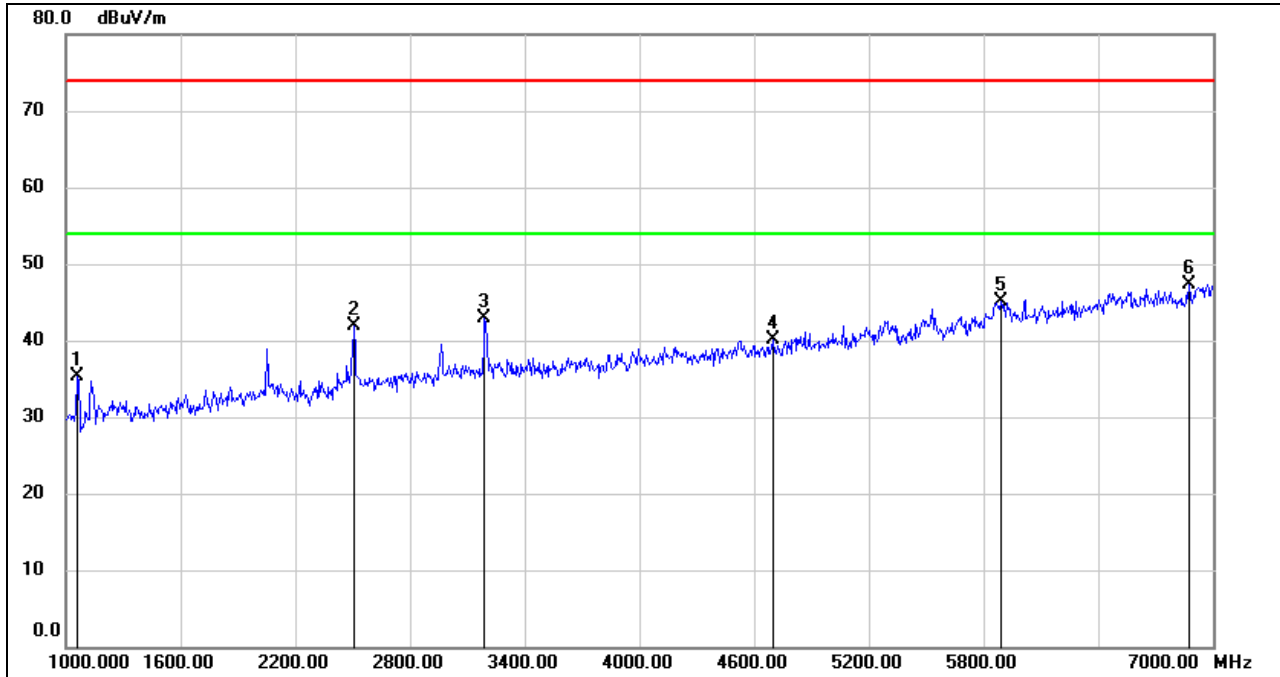

No.	Frequency (MHz)	Reading (dBuV)	Correct (dB/m)	Result (dBuV/m)	Limit (dBuV/m)	Margin (dB)	Remark
1	1060.000	49.83	-14.51	35.32	74.00	-38.68	peak
2	2506.000	49.99	-8.18	41.81	74.00	-32.19	peak
3	3190.000	48.91	-5.94	42.97	74.00	-31.03	peak
4	4696.000	41.48	-1.39	40.09	74.00	-33.91	peak
5	5890.000	40.40	4.68	45.08	74.00	-28.92	peak
6	6874.000	41.10	6.11	47.21	74.00	-26.79	peak

Note: 1. Measurement = Reading Level + Correct Factor.
 2. If Peak Result complies with AV limit, AV Result is deemed to comply with AV limit.
 3. Peak: Peak detector.
 4. Filter losses were only considered in then spurious frequency bands and the authorized band was not corrected for BRF losses.
 5. Proper operation of the transmitter prior to adding the filter to the measurement chain.
 6. Owing to the highest peak level complies with the lowest limit of unwanted emission out of the restricted bands (Please refer to page 72), so all the test point were deemed to comply with the limits list in the standard.



7-18GHz

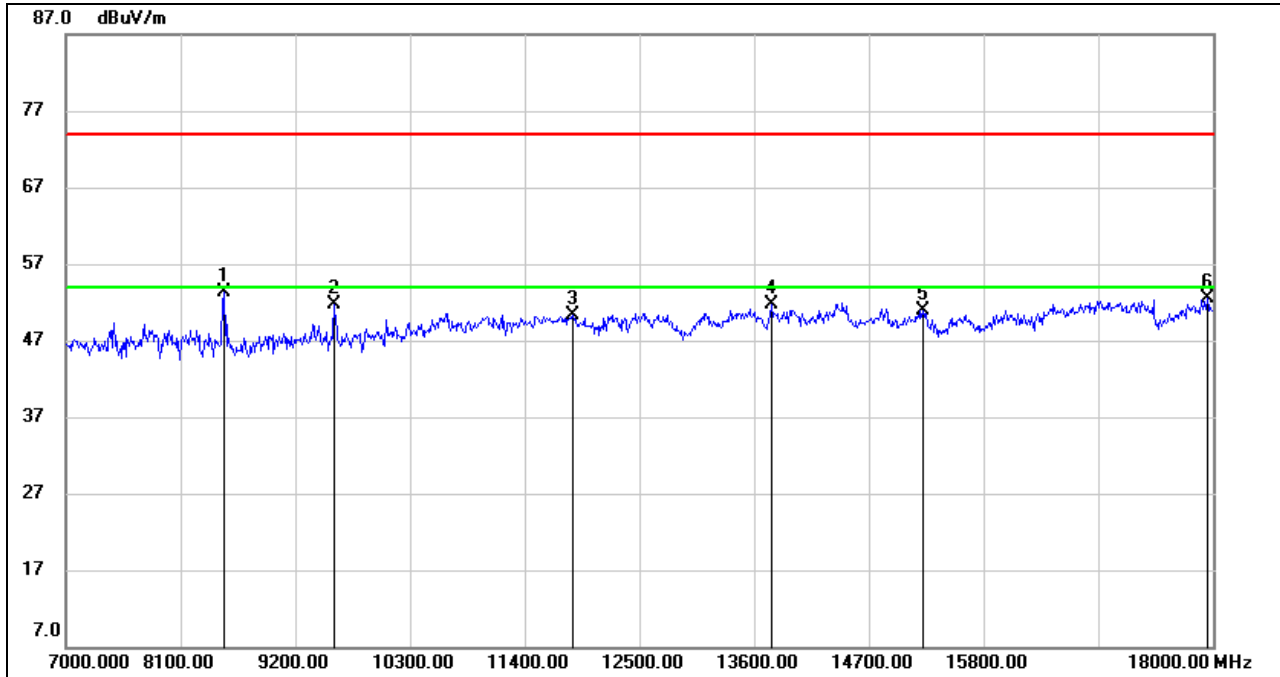

No.	Frequency (MHz)	Reading (dBuV)	Correct (dB/m)	Result (dBuV/m)	Limit (dBuV/m)	Margin (dB)	Remark
1	8518.000	44.11	9.21	53.32	74.00	-20.68	peak
2	9574.000	41.07	10.64	51.71	74.00	-22.29	peak
3	11862.000	35.90	14.47	50.37	74.00	-23.63	peak
4	13765.000	34.48	17.18	51.66	74.00	-22.34	peak
5	15217.000	34.87	16.04	50.91	74.00	-23.09	peak
6	17945.000	29.08	23.43	52.51	74.00	-21.49	peak

Note: 1. Measurement = Reading Level + Correct Factor.
 2. If Peak Result complies with AV limit, AV Result is deemed to comply with AV limit.
 3. Peak: Peak detector.
 4. Filter losses were only considered in the spurious frequency bands and the authorized band was not corrected for HPF losses.
 5. Proper operation of the transmitter prior to adding the filter to the measurement chain.
 6. Owing to the highest peak level complies with the lowest limit of unwanted emission out of the restricted bands (Please refer to page 72), so all the test point were deemed to comply with the limits list in the standard.



7.4.3. UNII-2C BAND

RESTRICTED BANDEDGE LOW CHANNEL

HORIZONTAL RESULTS
PEAK

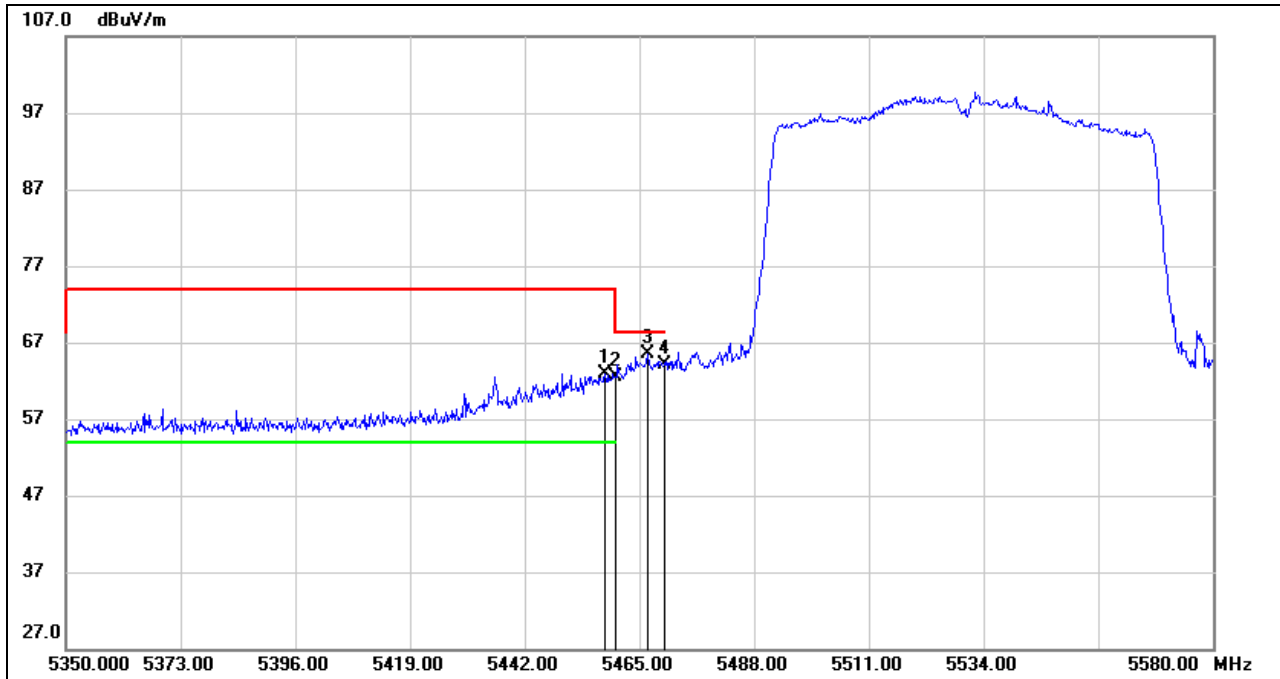

No.	Frequency (MHz)	Reading (dBuV)	Correct (dB/m)	Result (dBuV/m)	Limit (dBuV/m)	Margin (dB)	Remark
1	5458.100	21.74	41.26	63.00	74.00	-11.00	peak
2*	5460.000	21.20	41.28	62.48	68.20	-5.72	peak
3*	5466.610	24.19	41.37	65.56	68.20	-2.64	peak
4*	5470.000	22.78	41.41	64.19	68.20	-4.01	peak

Note: 1. Measurement = Reading Level + Correct Factor.
 2. If Peak Result complies with AV limit, AV Result is deemed to comply with AV limit.
 3. Peak: Peak detector.
 4.*indicates frequency out of the restricted bands
 5. Only the worst case emission will be recorded, if it complies with the limit, the other emissions deemed to comply with the limit.



AVG

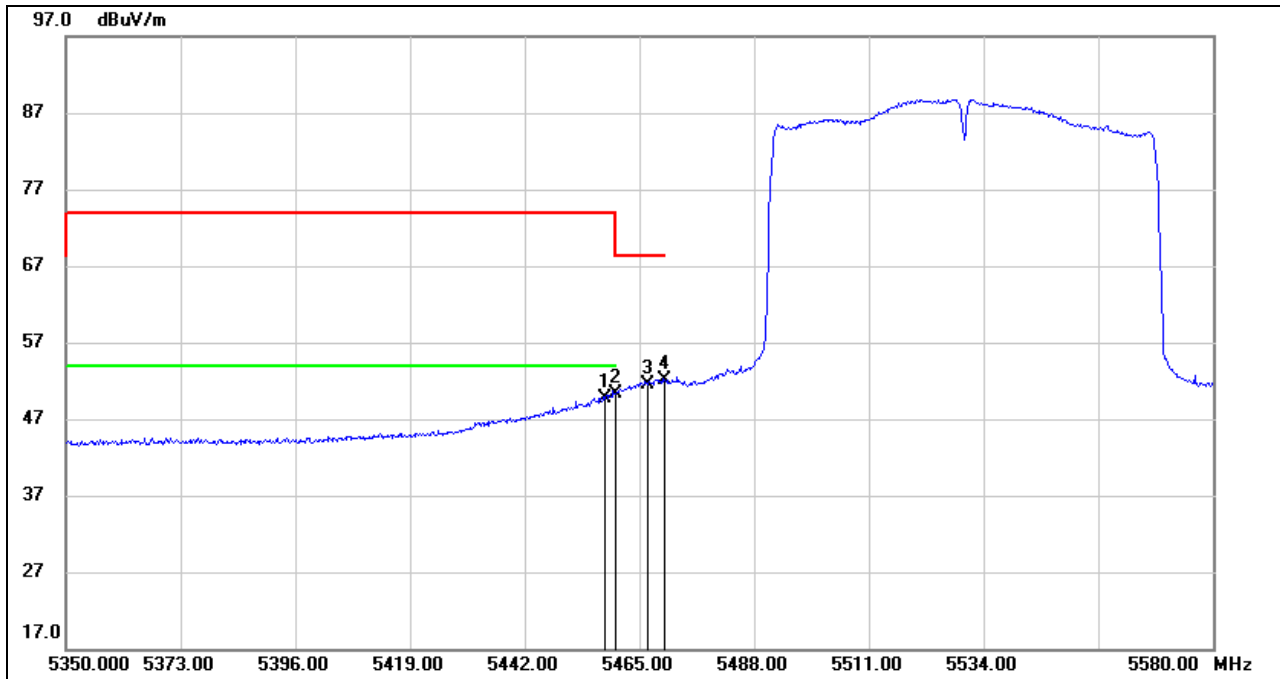

No.	Frequency (MHz)	Reading (dBuV)	Correct (dB/m)	Result (dBuV/m)	Limit (dBuV/m)	Margin (dB)	Remark
1	5458.100	8.40	41.26	49.66	54.00	-4.34	AVG
2	5460.000	9.00	41.28	50.28	54.00	-3.72	AVG
3*	5466.610	10.21	41.37	51.58	68.20	-16.62	AVG
4*	5470.000	10.62	41.41	52.03	68.20	-16.17	AVG

- Note:
1. Measurement = Reading Level + Correct Factor
 2. AVG:VBW=1/T,(For the value of 1/T, please refer to the table on page 25).
 3. For duty cycle, please refer to clause 6.1.
 - 4.*indicates frequency out of the restricted bands
 5. Only the worst case emission will be recorded, if it complies with the limit, the other emissions deemed to comply with the limit.



VERTICAL RESULTS
PEAK

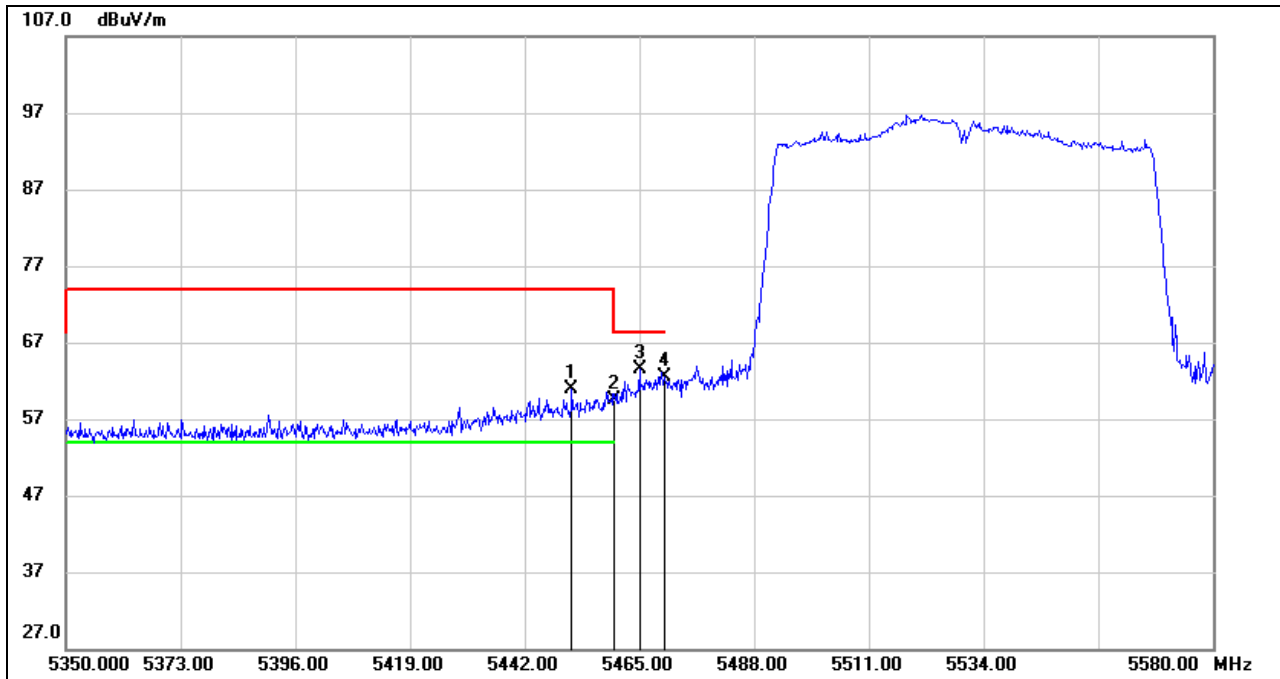

No.	Frequency (MHz)	Reading (dBuV)	Correct (dB/m)	Result (dBuV/m)	Limit (dBuV/m)	Margin (dB)	Remark
1	5451.430	19.70	41.17	60.87	74.00	-13.13	peak
2*	5460.000	18.27	41.28	59.55	68.20	-8.65	peak
3*	5465.000	22.08	41.35	63.43	68.20	-4.77	peak
4*	5470.000	21.15	41.41	62.56	68.20	-5.64	peak

Note: 1. Measurement = Reading Level + Correct Factor.
 2. If Peak Result complies with AV limit, AV Result is deemed to comply with AV limit.
 3. Peak: Peak detector.
 4.*indicates frequency out of the restricted bands
 5. Only the worst case emission will be recorded, if it complies with the limit, the other emissions deemed to comply with the limit.



AVG

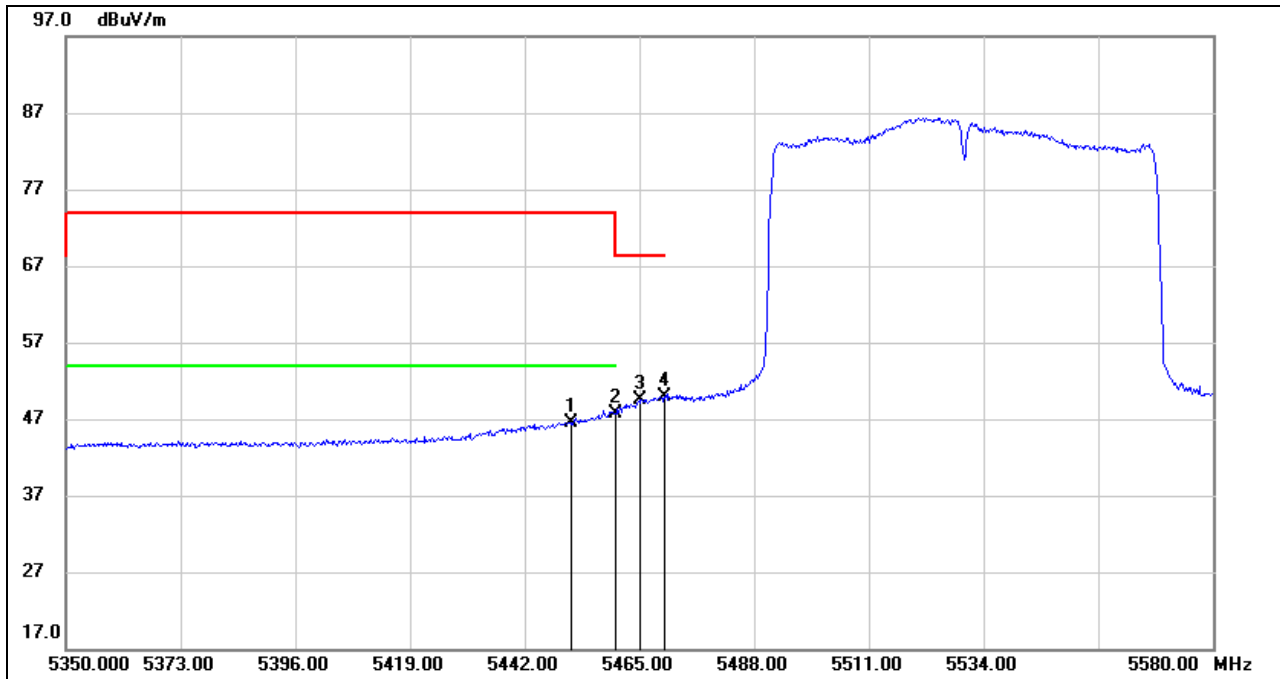

No.	Frequency (MHz)	Reading (dBuV)	Correct (dB/m)	Result (dBuV/m)	Limit (dBuV/m)	Margin (dB)	Remark
1	5451.430	5.33	41.17	46.50	54.00	-7.50	AVG
2	5460.000	6.47	41.28	47.75	54.00	-6.25	AVG
3*	5465.000	8.07	41.35	49.42	68.20	-18.78	AVG
4*	5470.000	8.46	41.41	49.87	68.20	-18.33	AVG

Note: 1. Measurement = Reading Level + Correct Factor
 2. AVG:VBW=1/T,(For the value of 1/T, please refer to the table on page 25).
 3. For duty cycle, please refer to clause 6.1.
 4.*indicates frequency out of the restricted bands
 5. Only the worst case emission will be recorded, if it complies with the limit, the other emissions deemed to comply with the limit.



RESTRICTED BANDEDGE HIGH CHANNEL

HORIZONTAL RESULTS
PEAK

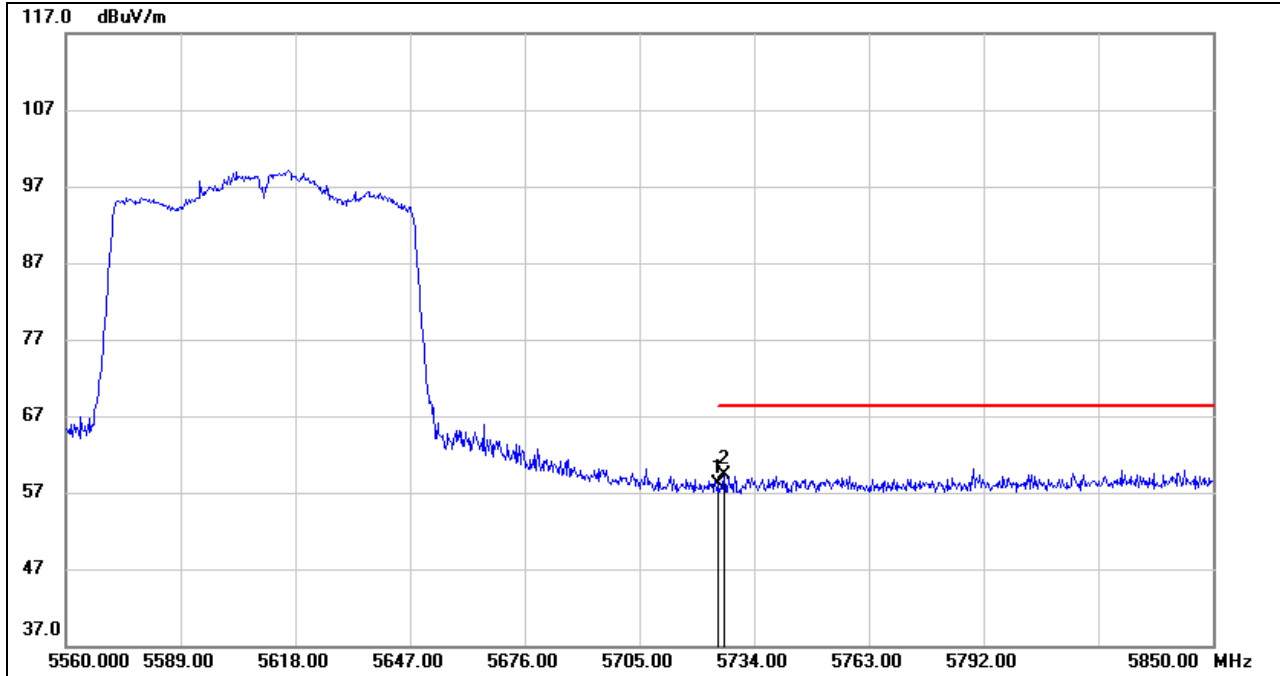

No.	Frequency (MHz)	Reading (dBuV)	Correct (dB/m)	Result (dBuV/m)	Limit (dBuV/m)	Margin (dB)	Remark
1*	5725.000	16.41	41.61	58.02	68.20	-10.18	peak
2*	5726.460	17.68	41.61	59.29	68.20	-8.91	peak

Note: 1. Measurement = Reading Level + Correct Factor.
 2. If Peak Result complies with AV limit, AV Result is deemed to comply with AV limit.
 3. Peak: Peak detector.
 4.*indicates frequency out of the restricted bands
 5. Only the worst case emission will be recorded, if it complies with the limit, the other emissions deemed to comply with the limit.



VERTICAL RESULTS
PEAK

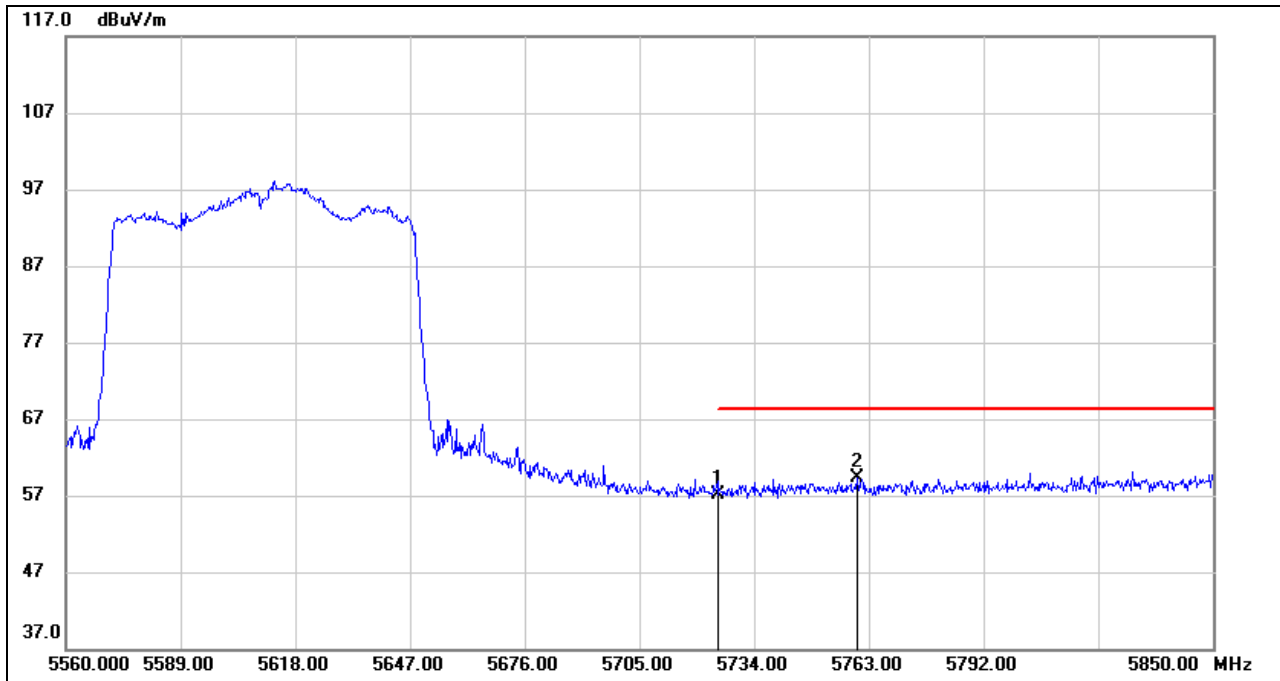

No.	Frequency (MHz)	Reading (dBuV)	Correct (dB/m)	Result (dBuV/m)	Limit (dBuV/m)	Margin (dB)	Remark
1*	5725.000	15.46	41.61	57.07	68.20	-11.13	peak
2*	5760.100	17.57	41.76	59.33	68.20	-8.87	peak

Note: 1. Measurement = Reading Level + Correct Factor.
 2. If Peak Result complies with AV limit, AV Result is deemed to comply with AV limit.
 3. Peak: Peak detector.
 4.*indicates frequency out of the restricted bands
 5. Only the worst case emission will be recorded, if it complies with the limit, the other emissions deemed to comply with the limit.

HARMONICS AND SPURIOUS EMISSIONS LOW CHANNEL

HORIZONTAL RESULTS
1-7GHz

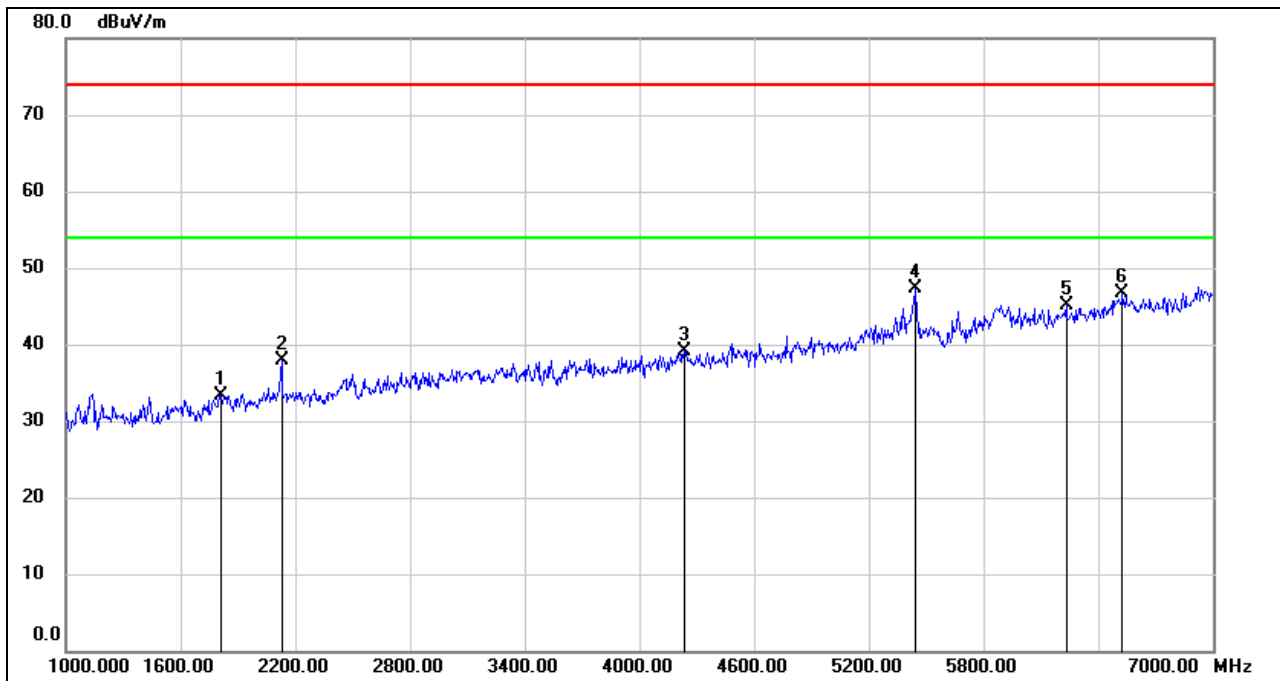

No.	Frequency (MHz)	Reading (dBuV)	Correct (dB/m)	Result (dBuV/m)	Limit (dBuV/m)	Margin (dB)	Remark
1	1810.000	44.23	-10.90	33.33	74.00	-40.67	peak
2	2128.000	48.02	-10.09	37.93	74.00	-36.07	peak
3	4234.000	42.10	-2.96	39.14	74.00	-34.86	peak
4	5440.000	45.89	1.45	47.34	74.00	-26.66	peak
5	6232.000	41.33	3.87	45.20	74.00	-28.80	peak
6	6526.000	40.96	5.80	46.76	74.00	-27.24	peak

Note: 1. Measurement = Reading Level + Correct Factor.
 2. If Peak Result complies with AV limit, AV Result is deemed to comply with AV limit.
 3. Peak: Peak detector.
 4. Filter losses were only considered in then spurious frequency bands and the authorized band was not corrected for BRF losses.
 5. Proper operation of the transmitter prior to adding the filter to the measurement chain.
 6. Owing to the highest peak level complies with the lowest limit of unwanted emission out of the restricted bands (Please refer to page 72), so all the test point were deemed to comply with the limits list in the standard.



HORIZONTAL RESULTS
7-18GHz

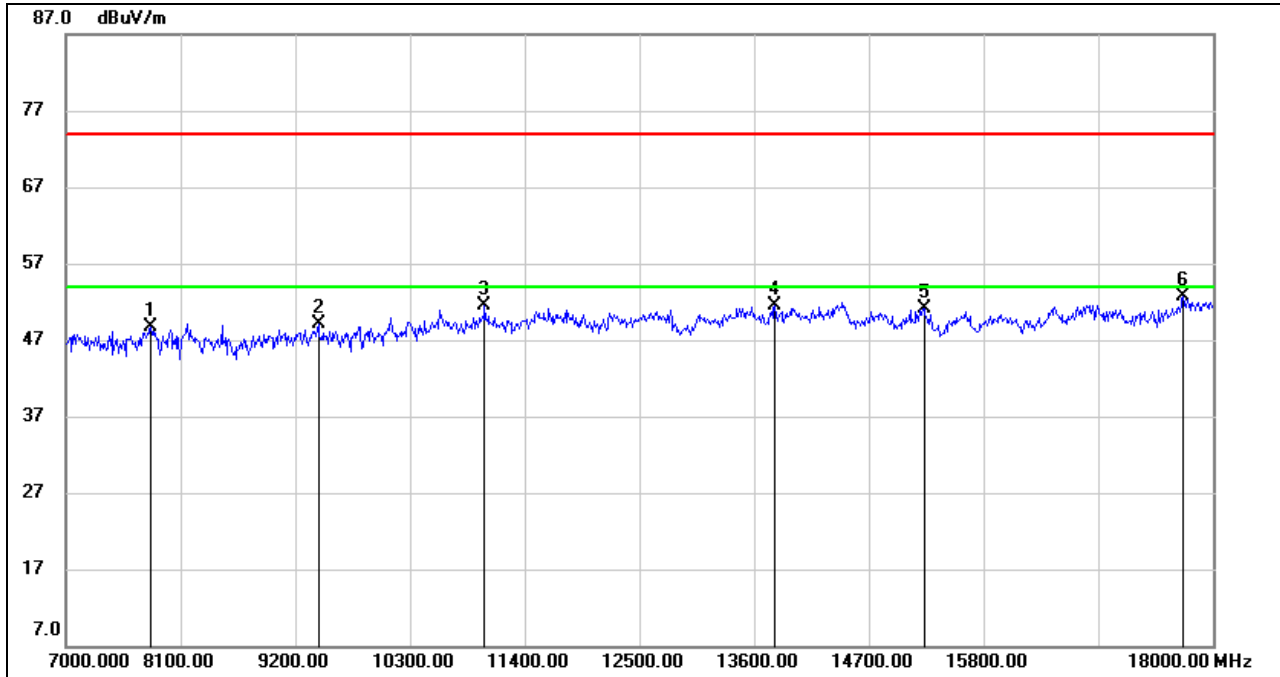

No.	Frequency (MHz)	Reading (dBuV)	Correct (dB/m)	Result (dBuV/m)	Limit (dBuV/m)	Margin (dB)	Remark
1	7814.000	39.14	9.58	48.72	74.00	-25.28	peak
2	9420.000	38.21	10.93	49.14	74.00	-24.86	peak
3	11015.000	37.78	13.65	51.43	74.00	-22.57	peak
4	13798.000	33.94	17.55	51.49	74.00	-22.51	peak
5	15228.000	35.06	16.03	51.09	74.00	-22.91	peak
6	17714.000	30.05	22.71	52.76	74.00	-21.24	peak

Note: 1. Measurement = Reading Level + Correct Factor.
 2. If Peak Result complies with AV limit, AV Result is deemed to comply with AV limit.
 3. Peak: Peak detector.
 4. Filter losses were only considered in the spurious frequency bands and the authorized band was not corrected for HPF losses.
 5. Proper operation of the transmitter prior to adding the filter to the measurement chain.
 6. Owing to the highest peak level complies with the lowest limit of unwanted emission out of the restricted bands (Please refer to page 72), so all the test point were deemed to comply with the limits list in the standard.



VERTICAL RESULTS
1-7GHz

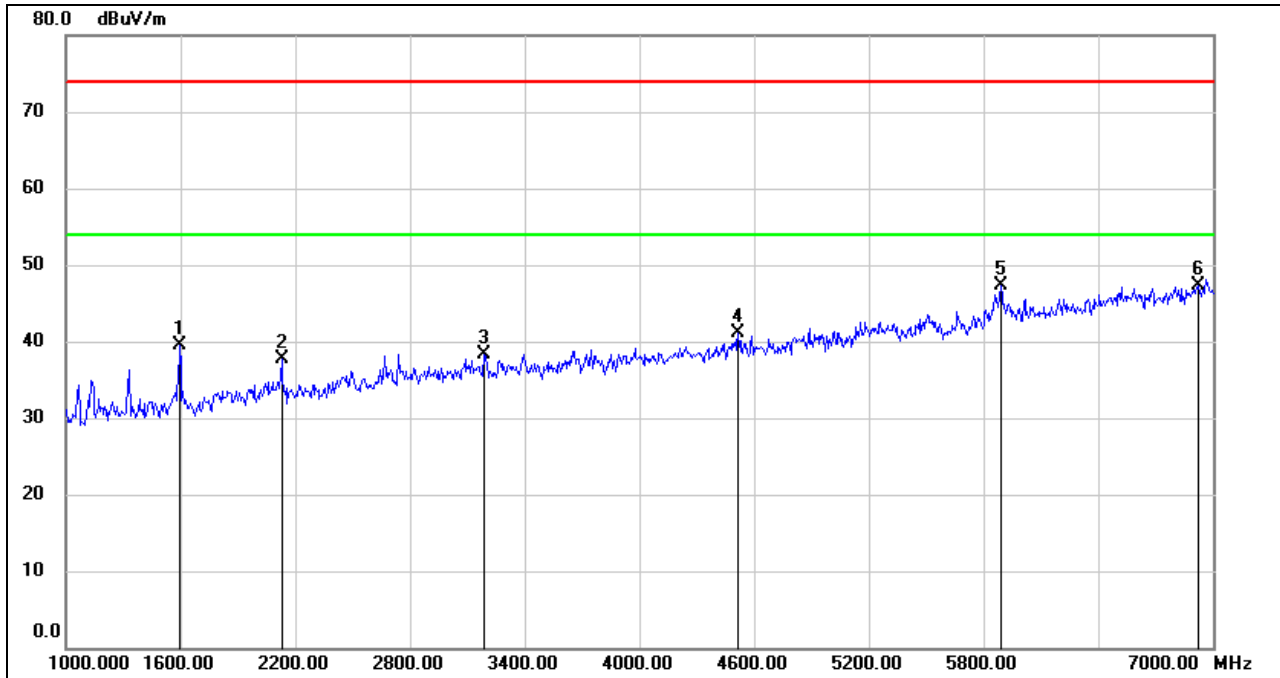

No.	Frequency (MHz)	Reading (dBuV)	Correct (dB/m)	Result (dBuV/m)	Limit (dBuV/m)	Margin (dB)	Remark
1	1594.000	51.85	-12.27	39.58	74.00	-34.42	peak
2	2128.000	47.82	-10.09	37.73	74.00	-36.27	peak
3	3184.000	44.28	-5.93	38.35	74.00	-35.65	peak
4	4516.000	43.21	-2.08	41.13	74.00	-32.87	peak
5	5890.000	42.68	4.68	47.36	74.00	-26.64	peak
6	6922.000	40.96	6.32	47.28	74.00	-26.72	peak

Note: 1. Measurement = Reading Level + Correct Factor.
 2. If Peak Result complies with AV limit, AV Result is deemed to comply with AV limit.
 3. Peak: Peak detector.
 4. Filter losses were only considered in then spurious frequency bands and the authorized band was not corrected for BRF losses.
 5. Proper operation of the transmitter prior to adding the filter to the measurement chain.
 6. Owing to the highest peak level complies with the lowest limit of unwanted emission out of the restricted bands (Please refer to page 72), so all the test point were deemed to comply with the limits list in the standard.



7-18GHz

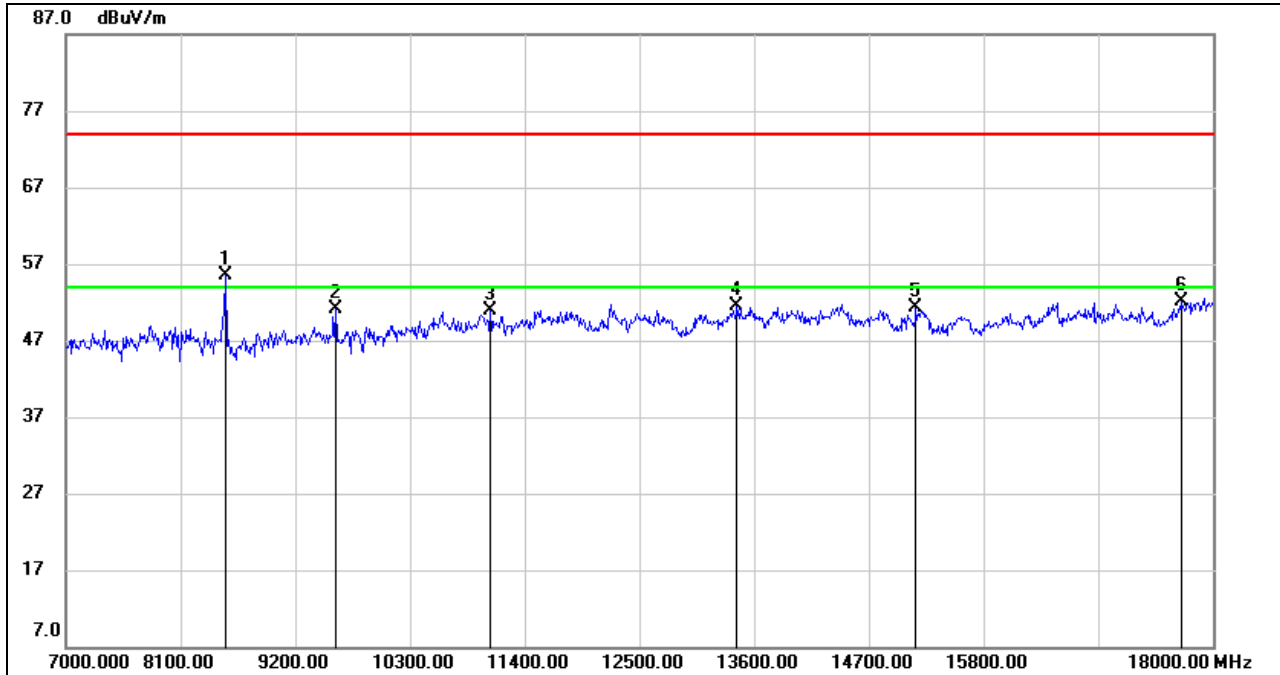

No.	Frequency (MHz)	Reading (dBuV)	Correct (dB/m)	Result (dBuV/m)	Limit (dBuV/m)	Margin (dB)	Remark
1*	8529.000	46.32	9.18	55.50	68.20	-12.70	peak
2	9585.000	40.46	10.62	51.08	74.00	-22.92	peak
3	11070.000	37.16	13.68	50.84	74.00	-23.16	peak
4	13435.000	35.08	16.37	51.45	74.00	-22.55	peak
5	15151.000	35.39	16.00	51.39	74.00	-22.61	peak
6	17692.000	29.53	22.54	52.07	74.00	-21.93	peak

- Note: 1. Measurement = Reading Level + Correct Factor.
 2. If Peak Result complies with AV limit, AV Result is deemed to comply with AV limit.
 3. Peak: Peak detector.
 4. Filter losses were only considered in the spurious frequency bands and the authorized band was not corrected for HPF losses.
 5. Proper operation of the transmitter prior to adding the filter to the measurement chain.
 6. Owing to the highest peak level complies with the lowest limit of unwanted emission out of the restricted bands (Please refer to page 72), so all the test point were deemed to comply with the limits list in the standard.
 7. *indicates frequency out of the restricted bands



HARMONICS AND SPURIOUS EMISSIONS HIGH CHANNEL

HORIZONTAL RESULTS
1-7GHz

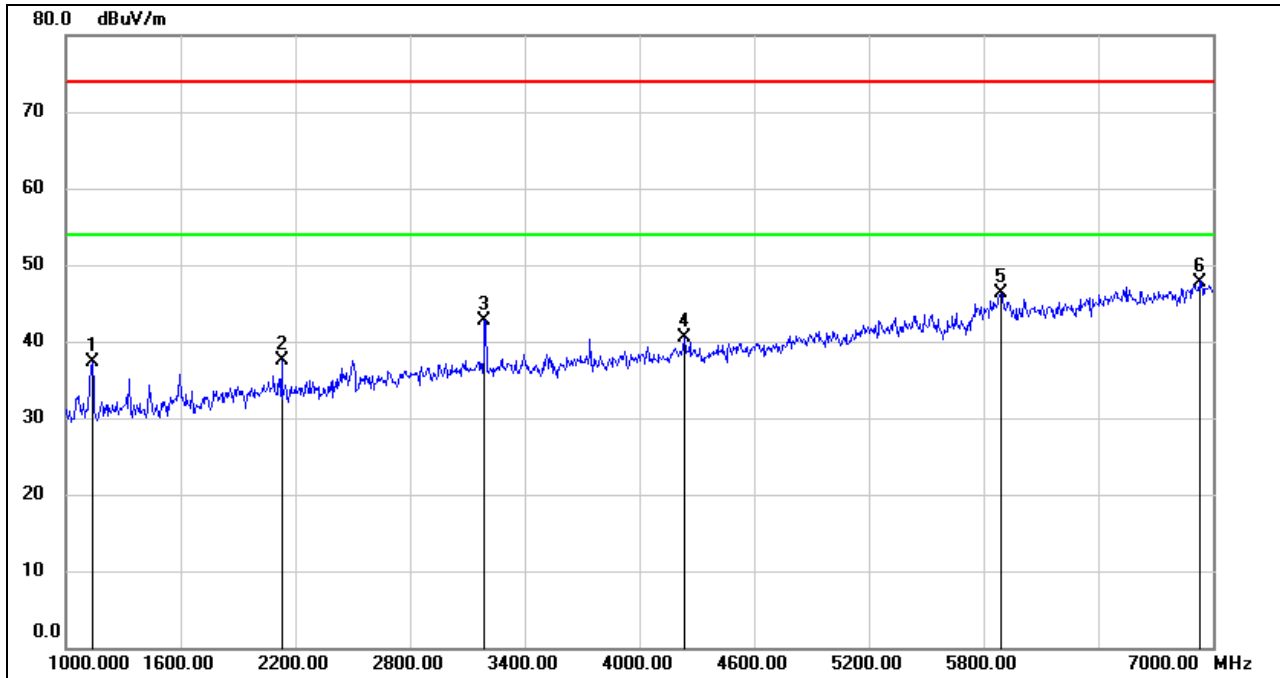

No.	Frequency (MHz)	Reading (dBuV)	Correct (dB/m)	Result (dBuV/m)	Limit (dBuV/m)	Margin (dB)	Remark
1	1138.000	51.39	-14.07	37.32	74.00	-36.68	peak
2	2128.000	47.53	-10.09	37.44	74.00	-36.56	peak
3	3190.000	48.58	-5.94	42.64	74.00	-31.36	peak
4	4234.000	43.51	-2.96	40.55	74.00	-33.45	peak
5	5890.000	41.68	4.68	46.36	74.00	-27.64	peak
6	6928.000	41.39	6.32	47.71	74.00	-26.29	peak

Note: 1. Measurement = Reading Level + Correct Factor.
 2. If Peak Result complies with AV limit, AV Result is deemed to comply with AV limit.
 3. Peak: Peak detector.
 4. Filter losses were only considered in then spurious frequency bands and the authorized band was not corrected for BRF losses.
 5. Proper operation of the transmitter prior to adding the filter to the measurement chain.
 6. Owing to the highest peak level complies with the lowest limit of unwanted emission out of the restricted bands (Please refer to page 72), so all the test point were deemed to comply with the limits list in the standard.



HORIZONTAL RESULTS
7-18GHz

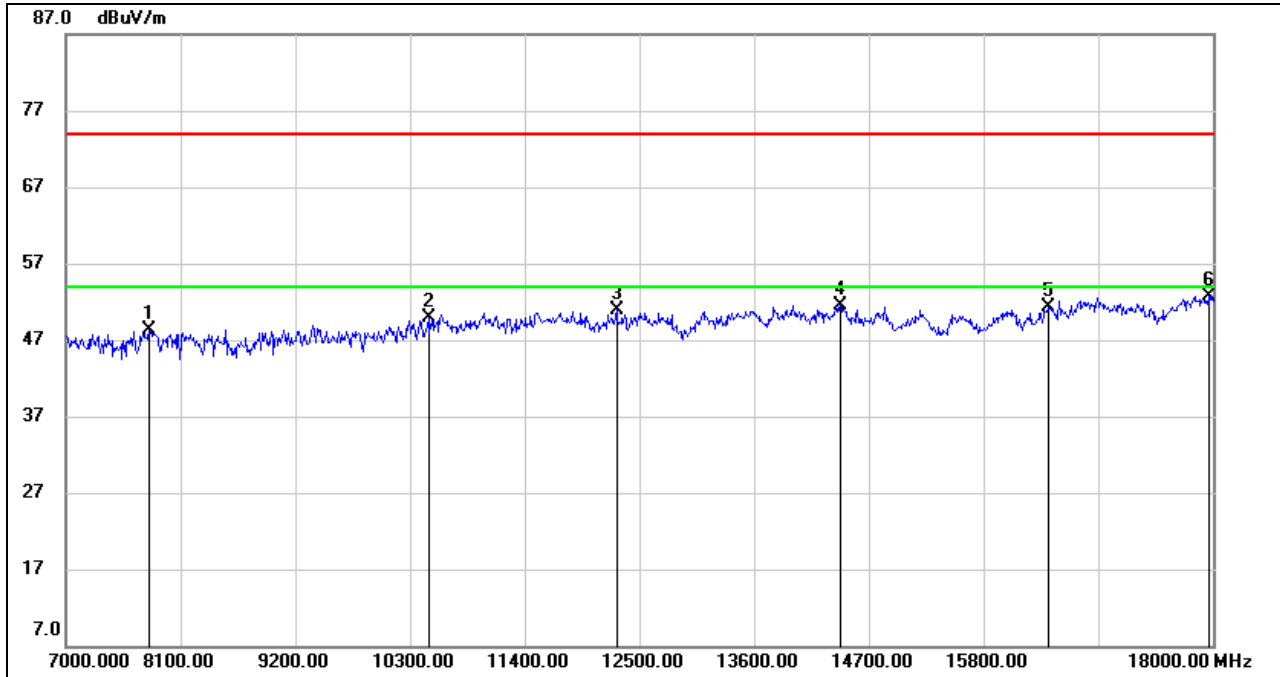

No.	Frequency (MHz)	Reading (dBuV)	Correct (dB/m)	Result (dBuV/m)	Limit (dBuV/m)	Margin (dB)	Remark
1	7792.000	38.81	9.54	48.35	74.00	-25.65	peak
2	10476.000	37.76	12.23	49.99	74.00	-24.01	peak
3	12280.000	35.93	14.99	50.92	74.00	-23.08	peak
4	14425.000	34.63	16.97	51.60	74.00	-22.40	peak
5	16416.000	31.83	19.47	51.30	74.00	-22.70	peak
6	17956.000	29.35	23.45	52.80	74.00	-21.20	peak

Note: 1. Measurement = Reading Level + Correct Factor.
 2. If Peak Result complies with AV limit, AV Result is deemed to comply with AV limit.
 3. Peak: Peak detector.
 4. Filter losses were only considered in the spurious frequency bands and the authorized band was not corrected for HPF losses.
 5. Proper operation of the transmitter prior to adding the filter to the measurement chain.
 6. Owing to the highest peak level complies with the lowest limit of unwanted emission out of the restricted bands (Please refer to page 72), so all the test point were deemed to comply with the limits list in the standard.

VERTICAL RESULTS
1-7GHz

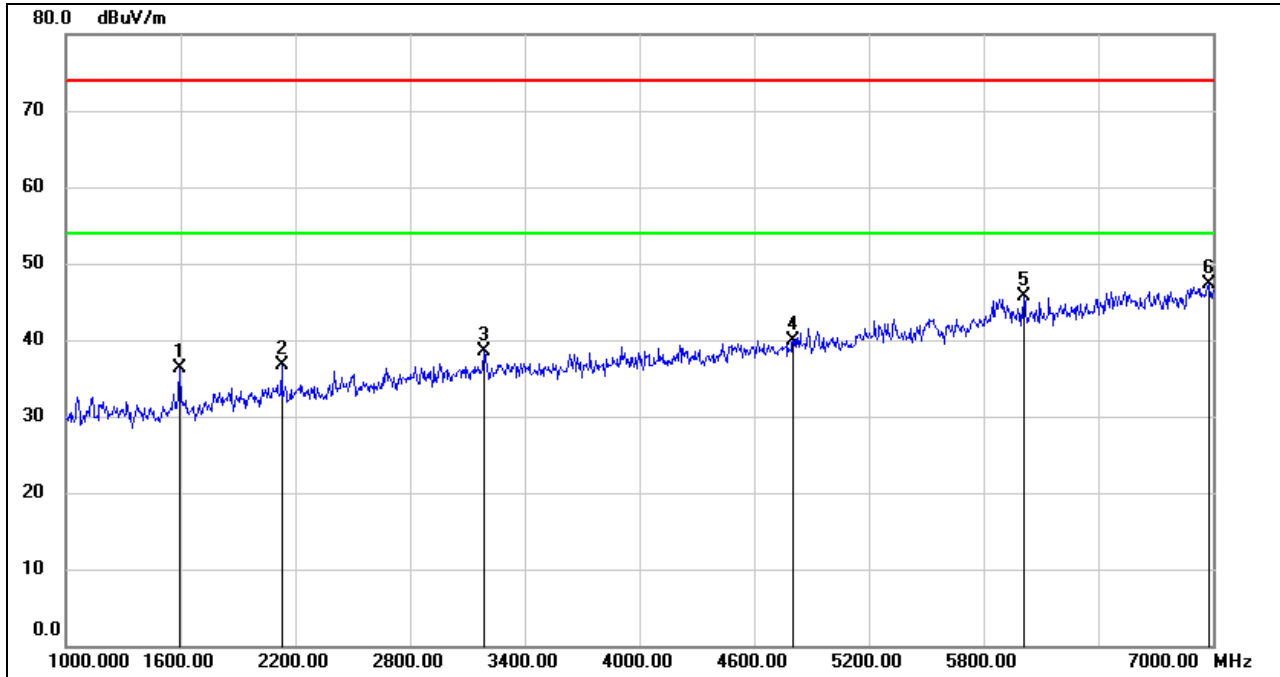

No.	Frequency (MHz)	Reading (dBuV)	Correct (dB/m)	Result (dBuV/m)	Limit (dBuV/m)	Margin (dB)	Remark
1	1594.000	48.54	-12.27	36.27	74.00	-37.73	peak
2	2128.000	46.79	-10.09	36.70	74.00	-37.30	peak
3	3184.000	44.39	-5.93	38.46	74.00	-35.54	peak
4	4804.000	40.90	-0.94	39.96	74.00	-34.04	peak
5	6010.000	42.35	3.30	45.65	74.00	-28.35	peak
6	6976.000	40.94	6.39	47.33	74.00	-26.67	peak

Note: 1. Measurement = Reading Level + Correct Factor.
 2. If Peak Result complies with AV limit, AV Result is deemed to comply with AV limit.
 3. Peak: Peak detector.
 4. Filter losses were only considered in then spurious frequency bands and the authorized band was not corrected for BRF losses.
 5. Proper operation of the transmitter prior to adding the filter to the measurement chain.
 6. Owing to the highest peak level complies with the lowest limit of unwanted emission out of the restricted bands (Please refer to page 72), so all the test point were deemed to comply with the limits list in the standard.



7-18GHz

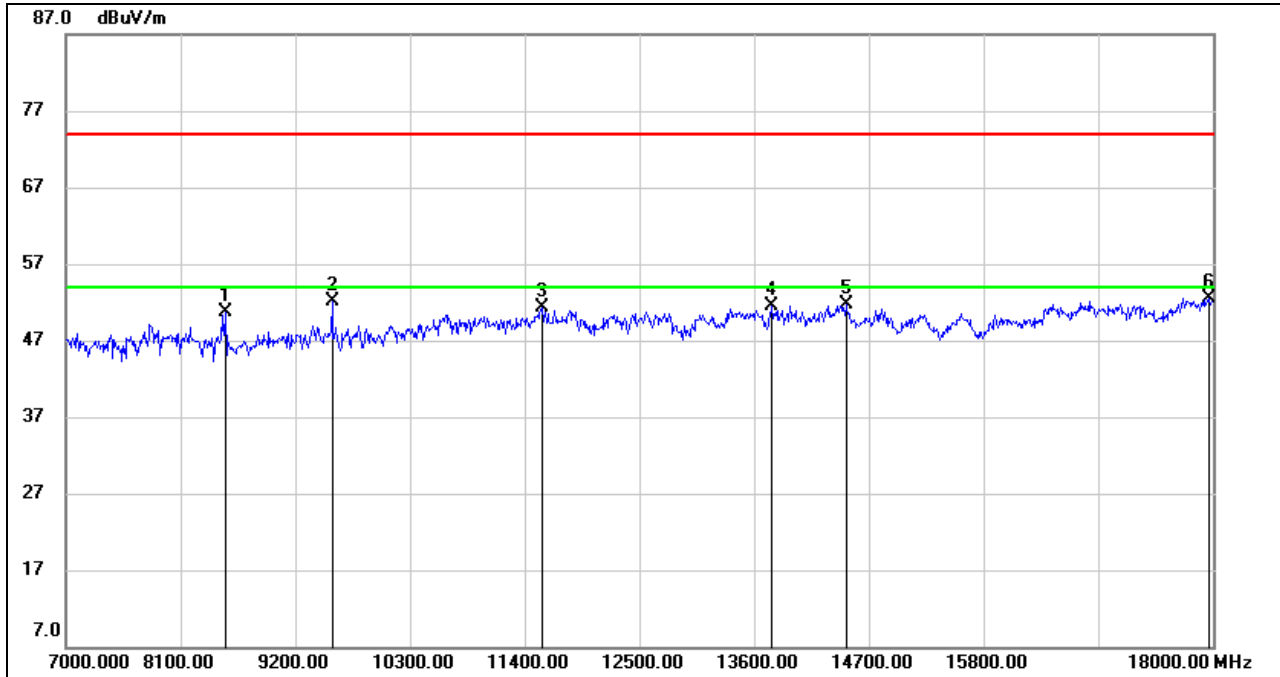

No.	Frequency (MHz)	Reading (dBuV)	Correct (dB/m)	Result (dBuV/m)	Limit (dBuV/m)	Margin (dB)	Remark
1	8529.000	41.43	9.18	50.61	74.00	-23.39	peak
2	9552.000	41.49	10.68	52.17	74.00	-21.83	peak
3	11565.000	36.66	14.56	51.22	74.00	-22.78	peak
4	13765.000	34.36	17.18	51.54	74.00	-22.46	peak
5	14480.000	34.81	16.87	51.68	74.00	-22.32	peak
6	17967.000	29.12	23.45	52.57	74.00	-21.43	peak

Note: 1. Measurement = Reading Level + Correct Factor.
 2. If Peak Result complies with AV limit, AV Result is deemed to comply with AV limit.
 3. Peak: Peak detector.
 4. Filter losses were only considered in the spurious frequency bands and the authorized band was not corrected for HPF losses.
 5. Proper operation of the transmitter prior to adding the filter to the measurement chain.
 6. Owing to the highest peak level complies with the lowest limit of unwanted emission out of the restricted bands (Please refer to page 72), so all the test point were deemed to comply with the limits list in the standard.



7.4.4. STRADDLE CHANNEL 138

HARMONICS AND SPURIOUS EMISSIONS HIGH CHANNEL

HORIZONTAL RESULTS
1-7GHz

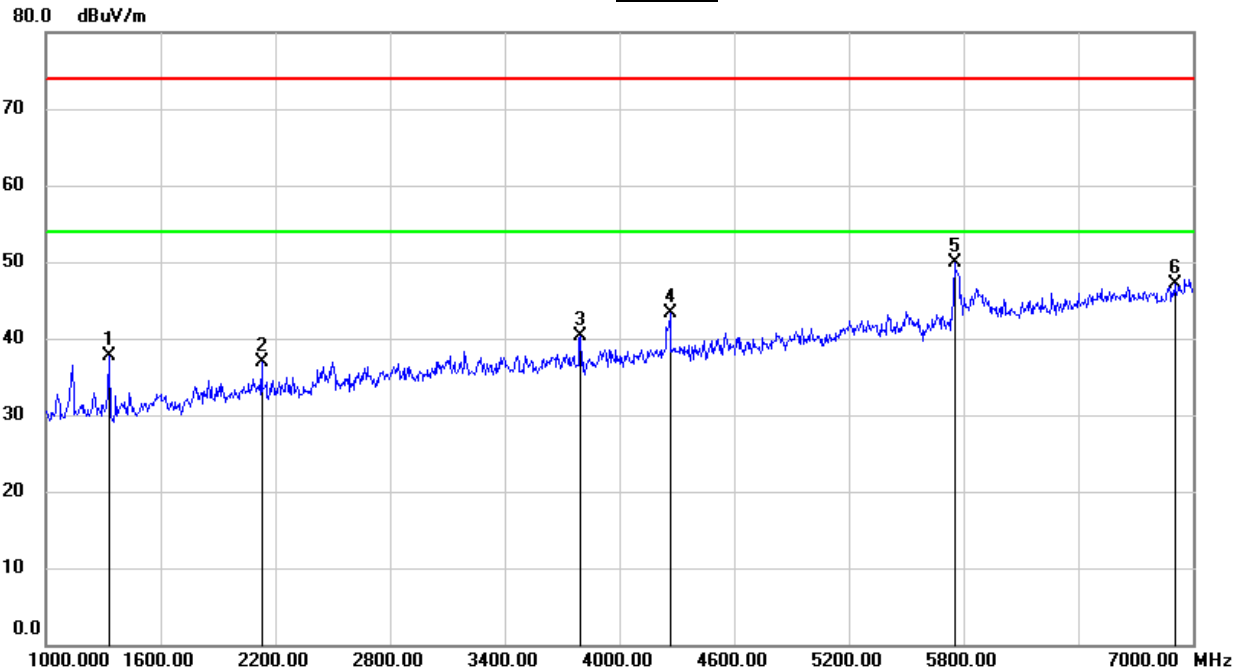

No.	Frequency (MHz)	Reading (dBuV)	Correct (dB/m)	Result (dBuV/m)	Limit (dBuV/m)	Margin (dB)	Remark
1	1330.000	50.79	-13.18	37.61	74.00	-36.39	peak
2	2128.000	47.07	-10.09	36.98	74.00	-37.02	peak
3	3796.000	44.55	-4.21	40.34	74.00	-33.66	peak
4	4264.000	46.33	-3.11	43.22	74.00	-30.78	peak
5	5752.000	47.35	2.57	49.92	74.00	-24.08	peak
6	6904.000	40.75	6.30	47.05	74.00	-26.95	peak

- Note: 1. Measurement = Reading Level + Correct Factor.
 2. If Peak Result complies with AV limit, AV Result is deemed to comply with AV limit.
 3. Peak: Peak detector.
 4. Filter losses were only considered in then spurious frequency bands and the authorized band was not corrected for BRF losses.
 5. Proper operation of the transmitter prior to adding the filter to the measurement chain.
 6. Owing to the highest peak level complies with the lowest limit of unwanted emission out of the restricted bands (Please refer to page 72), so all the test point were deemed to comply with the limits list in the standard.



HORIZONTAL RESULTS
7-18GHz

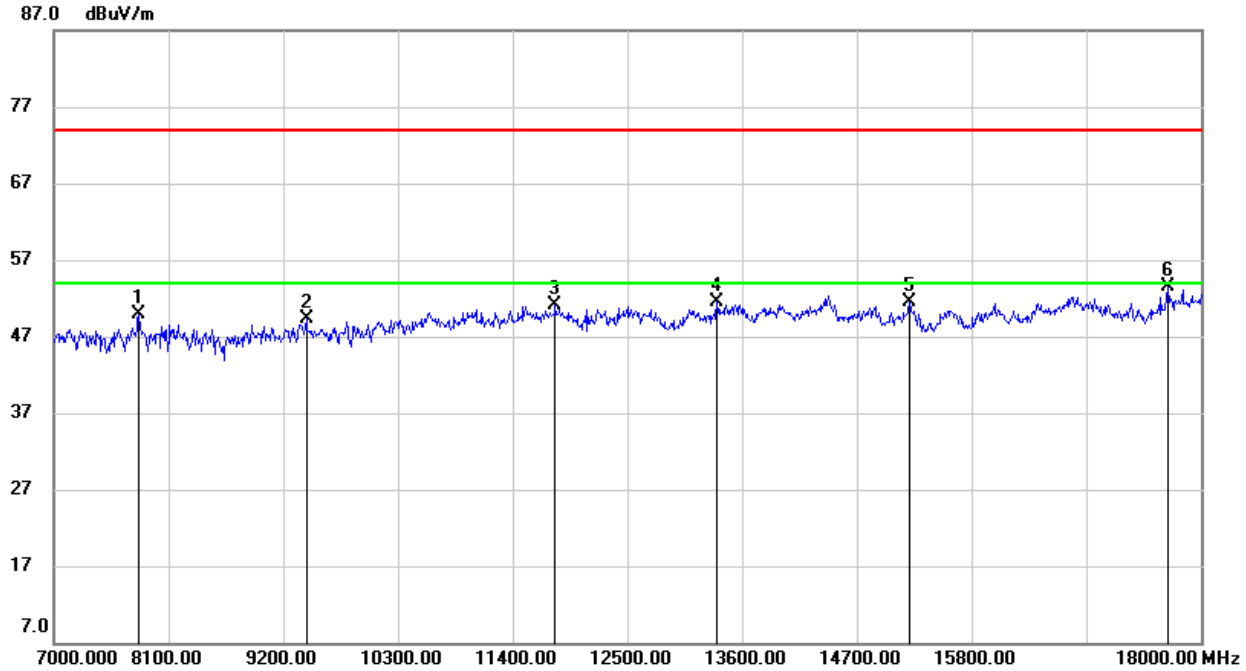

No.	Frequency (MHz)	Reading (dBuV)	Correct (dB/m)	Result (dBuV/m)	Limit (dBuV/m)	Margin (dB)	Remark
1	7814.000	40.29	9.58	49.87	74.00	-24.13	peak
2	9420.000	38.33	10.93	49.26	74.00	-24.74	peak
3	11807.000	36.75	14.39	51.14	74.00	-22.86	peak
4	13358.000	35.27	16.27	51.54	74.00	-22.46	peak
5	15206.000	35.44	16.06	51.50	74.00	-22.50	peak
6	17681.000	30.96	22.47	53.43	74.00	-20.57	peak

Note: 1. Measurement = Reading Level + Correct Factor.
 2. If Peak Result complies with AV limit, AV Result is deemed to comply with AV limit.
 3. Peak: Peak detector.
 4. Filter losses were only considered in the spurious frequency bands and the authorized band was not corrected for HPF losses.
 5. Proper operation of the transmitter prior to adding the filter to the measurement chain.
 6. Owing to the highest peak level complies with the lowest limit of unwanted emission out of the restricted bands (Please refer to page 72), so all the test point were deemed to comply with the limits list in the standard.



VERTICAL RESULTS

1-7GHz

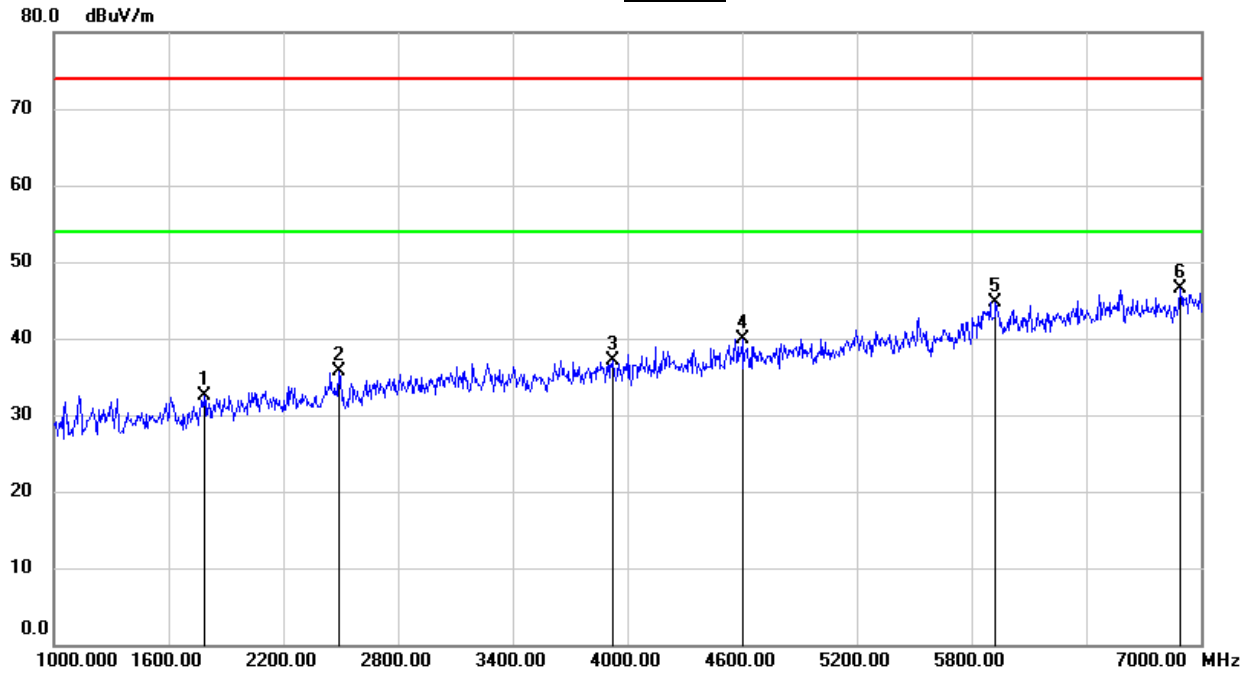

No.	Frequency (MHz)	Reading (dBuV)	Correct (dB/m)	Result (dBuV/m)	Limit (dBuV/m)	Margin (dB)	Remark
1	1786.000	43.65	-11.06	32.59	74.00	-41.41	peak
2	2488.000	43.94	-8.26	35.68	74.00	-38.32	peak
3	3922.000	41.35	-4.16	37.19	74.00	-36.81	peak
4	4600.000	42.01	-2.02	39.99	74.00	-34.01	peak
5	5926.000	40.21	4.46	44.67	74.00	-29.33	peak
6	6892.000	40.34	6.24	46.58	74.00	-27.42	peak

Note: 1. Measurement = Reading Level + Correct Factor.
 2. If Peak Result complies with AV limit, AV Result is deemed to comply with AV limit.
 3. Peak: Peak detector.
 4. Filter losses were only considered in then spurious frequency bands and the authorized band was not corrected for BRF losses.
 5. Proper operation of the transmitter prior to adding the filter to the measurement chain.
 6. Owing to the highest peak level complies with the lowest limit of unwanted emission out of the restricted bands (Please refer to page 72), so all the test point were deemed to comply with the limits list in the standard.



7-18GHz

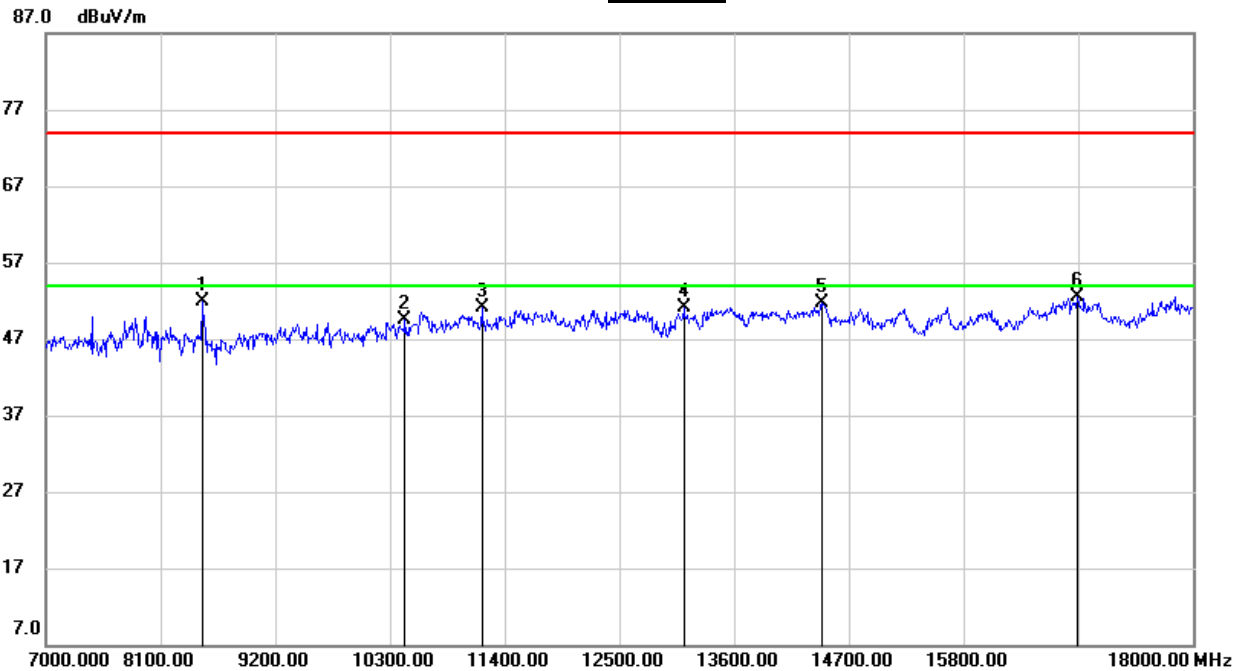

No.	Frequency (MHz)	Reading (dBuV)	Correct (dB/m)	Result (dBuV/m)	Limit (dBuV/m)	Margin (dB)	Remark
1	8496.000	42.59	9.26	51.85	74.00	-22.15	peak
2	10443.000	37.27	12.17	49.44	74.00	-24.56	peak
3	11180.000	37.36	13.79	51.15	74.00	-22.85	peak
4	13116.000	35.60	15.52	51.12	74.00	-22.88	peak
5	14447.000	34.75	16.93	51.68	74.00	-22.32	peak
6	16889.000	32.01	20.50	52.51	74.00	-21.49	peak

- Note: 1. Measurement = Reading Level + Correct Factor.
 2. If Peak Result complies with AV limit, AV Result is deemed to comply with AV limit.
 3. Peak: Peak detector.
 4. Filter losses were only considered in the spurious frequency bands and the authorized band was not corrected for HPF losses.
 5. Proper operation of the transmitter prior to adding the filter to the measurement chain.
 6. Owing to the highest peak level complies with the lowest limit of unwanted emission out of the restricted bands (Please refer to page 72), so all the test point were deemed to comply with the limits list in the standard.



7.4.5. UNII-3 BAND

RESTRICTED BANDEDGE LOW CHANNEL

HORIZONTAL RESULTS

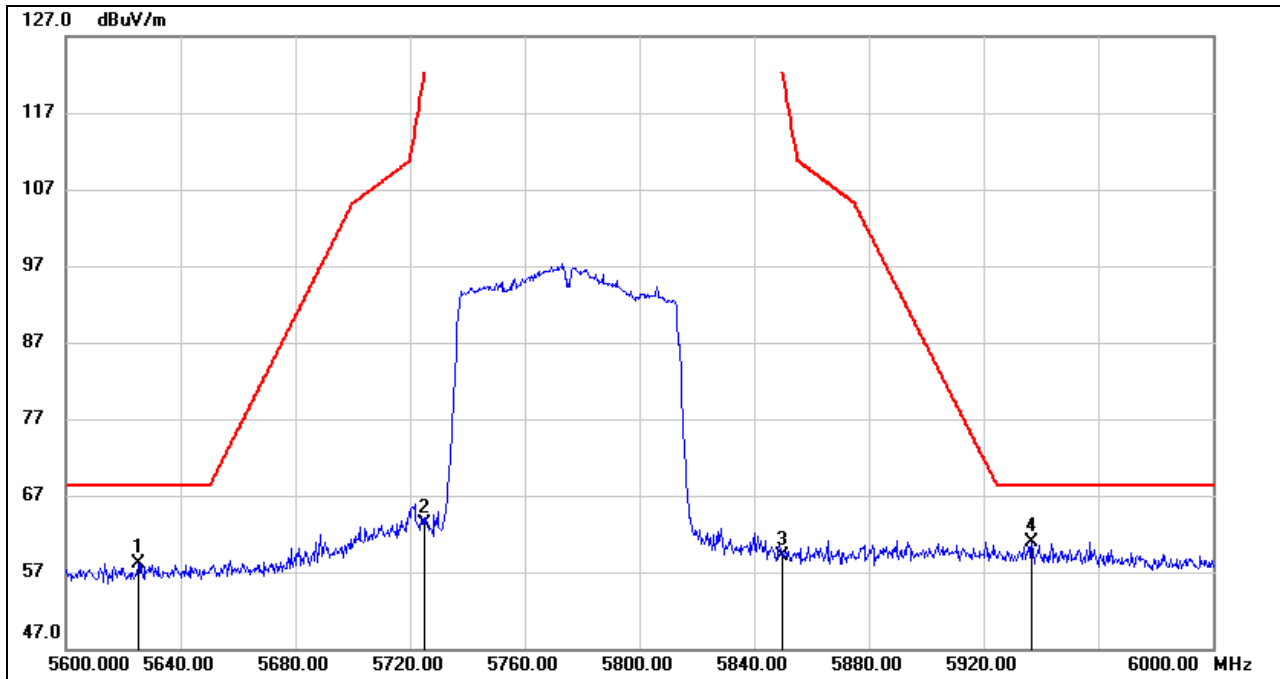

No.	Frequency (MHz)	Reading (dBuV)	Correct (dB/m)	Result (dBuV/m)	Limit (dBuV/m)	Margin (dB)	Remark
1	5625.200	16.72	41.47	58.19	68.20	-10.01	peak
2	5725.000	21.67	41.61	63.28	122.20	-58.92	peak
3	5850.000	16.18	42.89	59.07	122.20	-63.13	peak
4	5936.800	17.66	43.22	60.88	68.20	-7.32	peak

Note: 1. Measurement = Reading Level + Correct Factor.



VERTICAL RESULTS

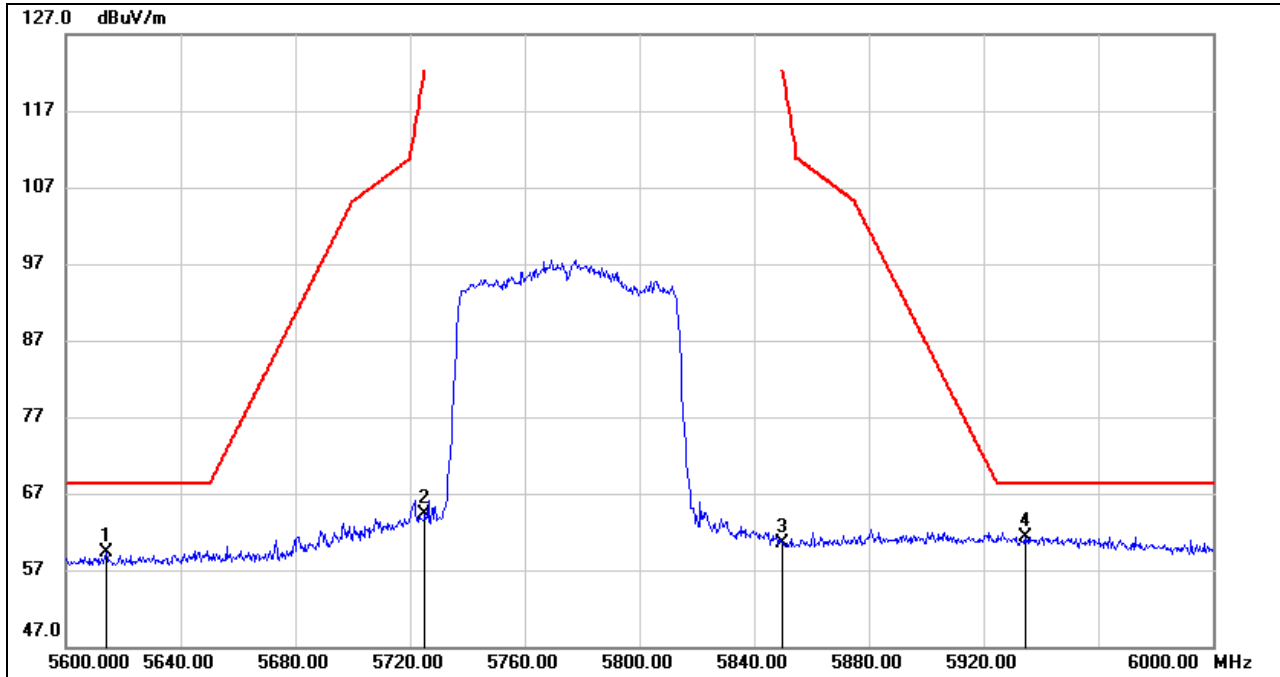

No.	Frequency (MHz)	Reading (dBuV)	Correct (dB/m)	Result (dBuV/m)	Limit (dBuV/m)	Margin (dB)	Remark
1	5614.000	17.81	41.47	59.28	68.20	-8.92	peak
2	5725.000	22.66	41.61	64.27	122.20	-57.93	peak
3	5850.000	17.66	42.89	60.55	122.20	-61.65	peak
4	5934.400	18.09	43.26	61.35	68.20	-6.85	peak

Note: 1. Measurement = Reading Level + Correct Factor.

HARMONICS AND SPURIOUS EMISSIONS LOW CHANNEL

HORIZONTAL RESULTS
1-7GHz

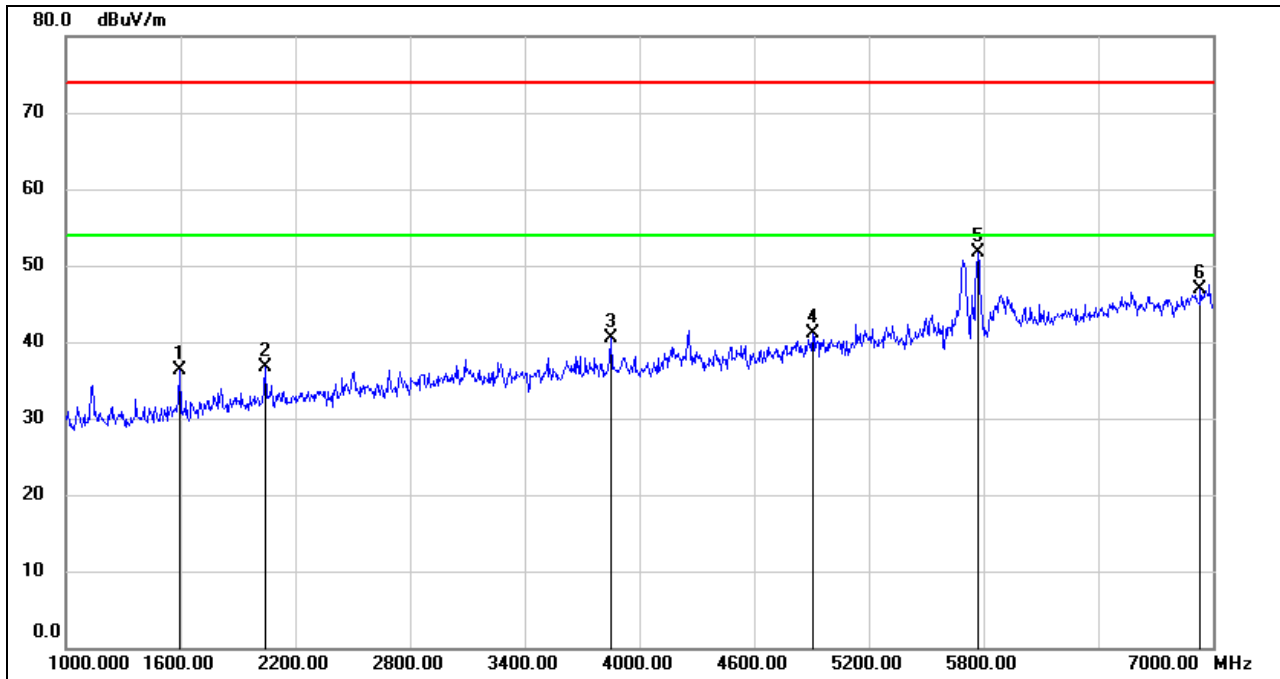

No.	Frequency (MHz)	Reading (dBuV)	Correct (dB/m)	Result (dBuV/m)	Limit (dBuV/m)	Margin (dB)	Remark
1	1594.000	48.54	-12.27	36.27	74.00	-37.73	peak
2	2044.000	47.35	-10.57	36.78	74.00	-37.22	peak
3	3850.000	44.66	-4.20	40.46	74.00	-33.54	peak
4	4906.000	41.79	-0.77	41.02	74.00	-32.98	peak
5	5770.000	48.96	2.70	51.66	74.00	-22.34	peak
6	6934.000	40.58	6.34	46.92	74.00	-27.08	peak

Note: 1. Measurement = Reading Level + Correct Factor.
 2. If Peak Result complies with AV limit, AV Result is deemed to comply with AV limit.
 3. Peak: Peak detector.
 4. Filter losses were only considered in then spurious frequency bands and the authorized band was not corrected for BRF losses.
 5. Proper operation of the transmitter prior to adding the filter to the measurement chain.
 6. Owing to the highest peak level complies with the lowest limit of unwanted emission out of the restricted bands (Please refer to page 72), so all the test point were deemed to comply with the limits list in the standard.

HORIZONTAL RESULTS
7-18GHz

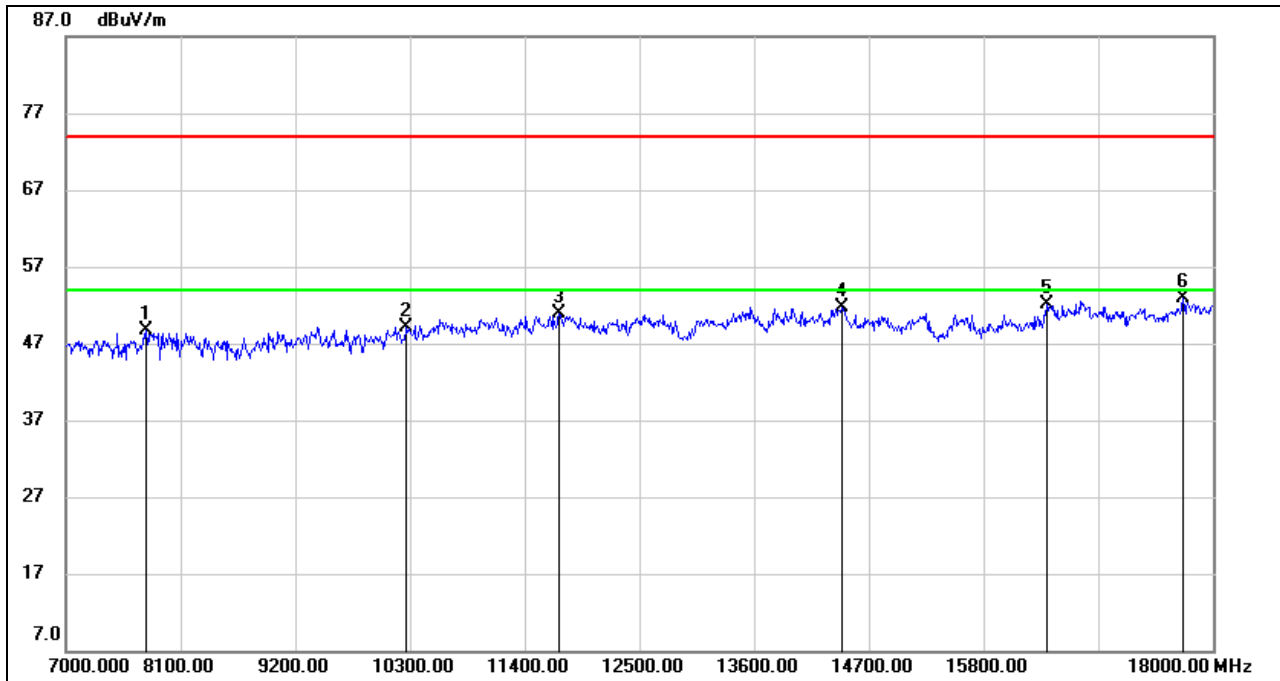

No.	Frequency (MHz)	Reading (dBuV)	Correct (dB/m)	Result (dBuV/m)	Limit (dBuV/m)	Margin (dB)	Remark
1	7770.000	39.55	9.24	48.79	74.00	-25.21	peak
2	10267.000	37.29	11.90	49.19	74.00	-24.81	peak
3	11730.000	36.64	14.22	50.86	74.00	-23.14	peak
4	14447.000	34.83	16.93	51.76	74.00	-22.24	peak
5	16405.000	32.66	19.43	52.09	74.00	-21.91	peak
6	17714.000	30.20	22.71	52.91	74.00	-21.09	peak

Note: 1. Measurement = Reading Level + Correct Factor.
 2. If Peak Result complies with AV limit, AV Result is deemed to comply with AV limit.
 3. Peak: Peak detector.
 4. Filter losses were only considered in the spurious frequency bands and the authorized band was not corrected for HPF losses.
 5. Proper operation of the transmitter prior to adding the filter to the measurement chain.
 6. Owing to the highest peak level complies with the lowest limit of unwanted emission out of the restricted bands (Please refer to page 72), so all the test point were deemed to comply with the limits list in the standard.

VERTICAL RESULTS
1-7GHz

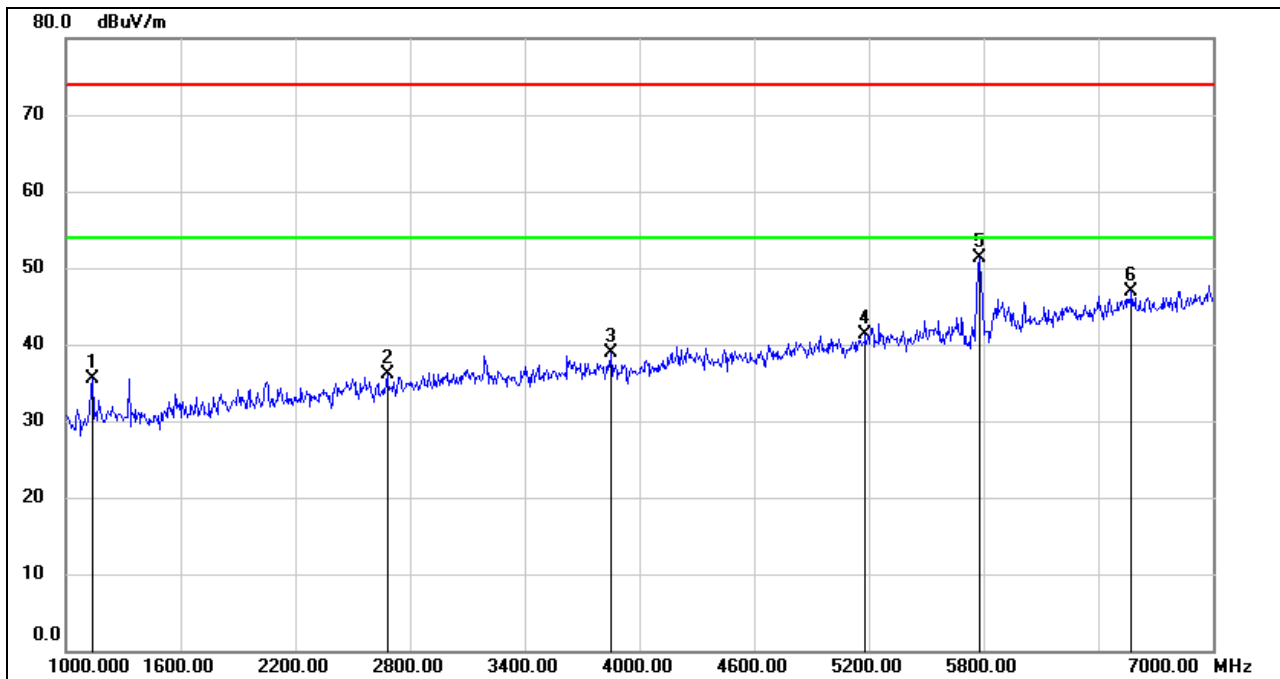

No.	Frequency (MHz)	Reading (dBuV)	Correct (dB/m)	Result (dBuV/m)	Limit (dBuV/m)	Margin (dB)	Remark
1	1138.000	49.66	-14.07	35.59	74.00	-38.41	peak
2	2680.000	44.08	-8.04	36.04	74.00	-37.96	peak
3	3850.000	43.12	-4.20	38.92	74.00	-35.08	peak
4	5182.000	40.57	0.77	41.34	74.00	-32.66	peak
5	5776.000	48.61	2.74	51.35	74.00	-22.65	peak
6	6574.000	41.39	5.61	47.00	74.00	-27.00	peak

Note: 1. Measurement = Reading Level + Correct Factor.
 2. If Peak Result complies with AV limit, AV Result is deemed to comply with AV limit.
 3. Peak: Peak detector.
 4. Filter losses were only considered in then spurious frequency bands and the authorized band was not corrected for BRF losses.
 5. Proper operation of the transmitter prior to adding the filter to the measurement chain.
 6. Owing to the highest peak level complies with the lowest limit of unwanted emission out of the restricted bands (Please refer to page 72), so all the test point were deemed to comply with the limits list in the standard.



7-18GHz

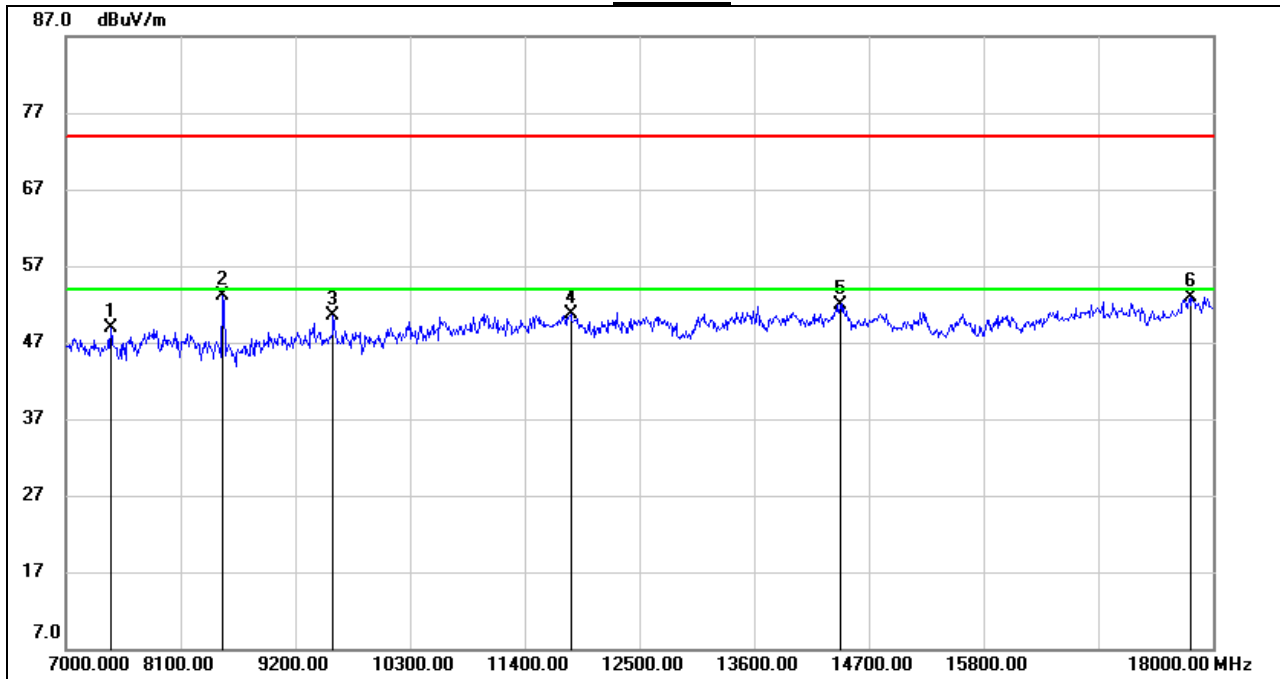

No.	Frequency (MHz)	Reading (dBuV)	Correct (dB/m)	Result (dBuV/m)	Limit (dBuV/m)	Margin (dB)	Remark
1	7429.000	40.70	8.28	48.98	74.00	-25.02	peak
2	8496.000	43.92	9.26	53.18	74.00	-20.82	peak
3	9563.000	39.82	10.65	50.47	74.00	-23.53	peak
4	11840.000	36.19	14.45	50.64	74.00	-23.36	peak
5	14425.000	35.01	16.97	51.98	74.00	-22.02	peak
6	17780.000	29.67	23.28	52.95	74.00	-21.05	peak

Note: 1. Measurement = Reading Level + Correct Factor.
 2. If Peak Result complies with AV limit, AV Result is deemed to comply with AV limit.
 3. Peak: Peak detector.
 4. Filter losses were only considered in the spurious frequency bands and the authorized band was not corrected for HPF losses.
 5. Proper operation of the transmitter prior to adding the filter to the measurement chain.
 6. Owing to the highest peak level complies with the lowest limit of unwanted emission out of the restricted bands (Please refer to page 72), so all the test point were deemed to comply with the limits list in the standard.



7.5. SPURIOUS EMISSIONS 18~26GHz

7.5.1. 802.11HT20 HIGH MODE (WORST-CASE CONFIGURATION)

SPURIOUS EMISSIONS (HIGH CHANNEL, HORIZONTAL)

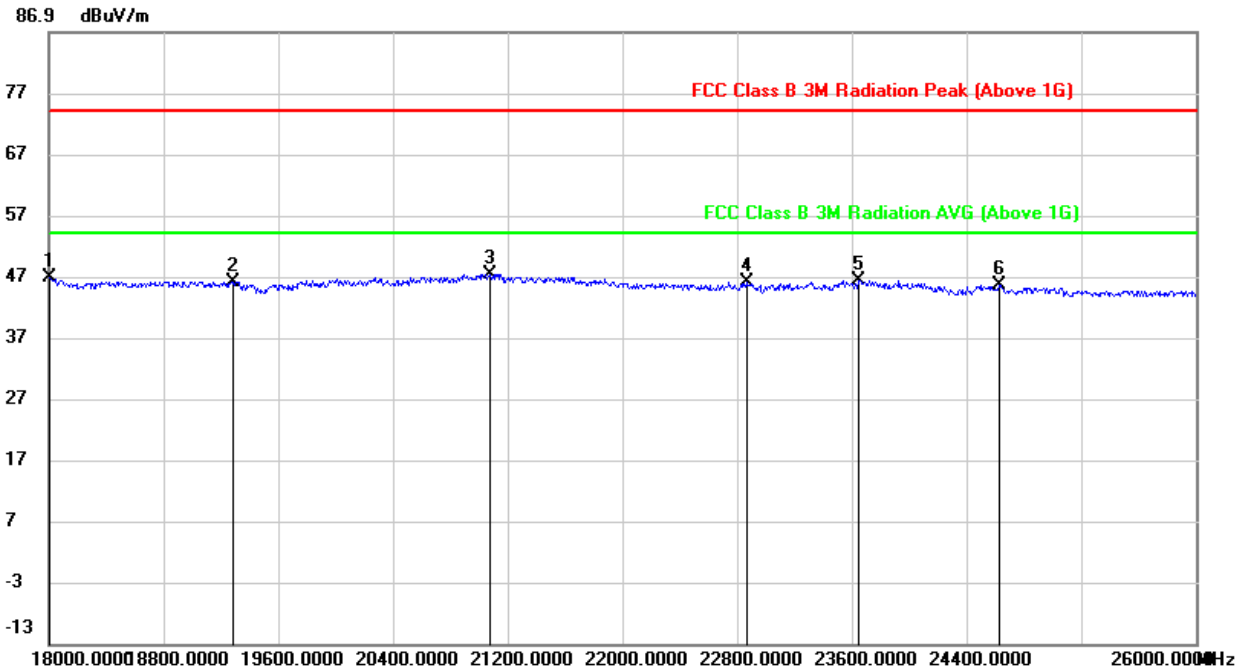

No.	Frequency (MHz)	Reading (dBuV)	Correct (dB/m)	Result (dBuV/m)	Limit (dBuV/m)	Margin (dB)	Remark
1	18008.000	50.64	-3.89	46.75	74.00	-27.25	peak
2	19280.000	51.16	-5.01	46.15	74.00	-27.85	peak
3	21072.000	52.72	-5.34	47.38	74.00	-26.62	peak
4	22864.000	51.80	-5.68	46.12	74.00	-27.88	peak
5	23648.000	51.07	-4.69	46.38	74.00	-27.62	peak
6	24632.000	47.83	-2.25	45.58	74.00	-28.42	peak

Note: 1. Measurement = Reading Level + Correct Factor.
 2. If Peak Result complies with AV limit, AV Result is deemed to comply with AV limit.
 3. Peak: Peak detector.
 4. The preamplifier only effect to the above 18GHz signal and no filter added to the measurement chain.



SPURIOUS EMISSIONS (HIGH CHANNEL, VERTICAL)

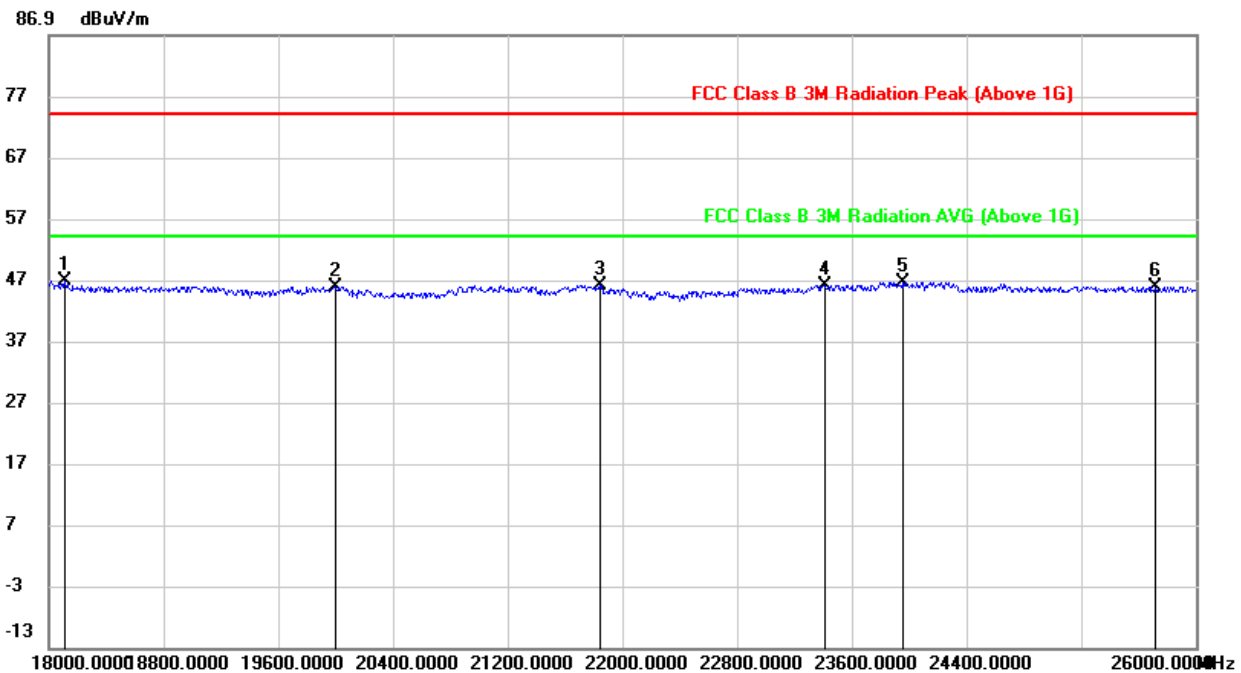

No.	Frequency (MHz)	Reading (dBuV)	Correct (dB/m)	Result (dBuV/m)	Limit (dBuV/m)	Margin (dB)	Remark
1	18112.000	50.85	-4.10	46.75	74.00	-27.25	peak
2	20000.000	50.23	-4.37	45.86	74.00	-28.14	peak
3	21840.000	52.08	-5.93	46.15	74.00	-27.85	peak
4	23408.000	51.05	-4.94	46.11	74.00	-27.89	peak
5	23952.000	50.78	-4.13	46.65	74.00	-27.35	peak
6	25720.000	47.28	-1.39	45.89	74.00	-28.11	peak

Note: 1. Measurement = Reading Level + Correct Factor.
 2. If Peak Result complies with AV limit, AV Result is deemed to comply with AV limit.
 3. Peak: Peak detector.
 4. The preamplifier only effect to the above 18GHz signal and no filter added to the measurement chain.



7.6. SPURIOUS EMISSIONS 26~40GHz

7.6.1. 802.11HT20 HIGH MODE

(WORST-CASE CONFIGURATION)

SPURIOUS EMISSIONS (HIGH CHANNEL, HORIZONTAL)

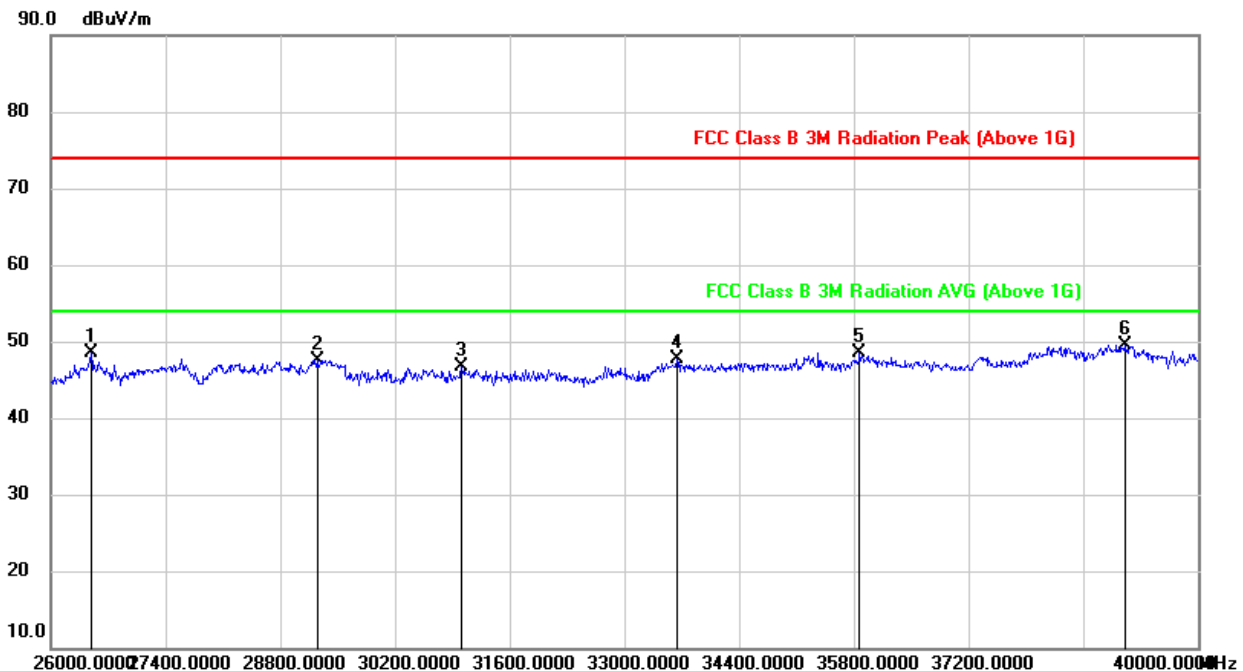

No.	Frequency (MHz)	Reading (dBuV)	Correct (dB/m)	Result (dBuV/m)	Limit (dBuV/m)	Margin (dB)	Remark
1	26490.000	53.29	-4.74	48.55	74.00	-25.45	peak
2	29248.000	48.65	-1.05	47.60	74.00	-26.40	peak
3	31012.000	47.33	-0.71	46.62	74.00	-27.38	peak
4	33644.000	47.31	0.42	47.73	74.00	-26.27	peak
5	35870.000	44.83	3.75	48.58	74.00	-25.42	peak
6	39104.000	45.24	4.26	49.50	74.00	-24.50	peak

- Note:
1. Measurement = Reading Level + Correct Factor.
 2. If Peak Result complies with AV limit, AV Result is deemed to comply with AV limit.
 3. Peak: Peak detector.
 4. The preamplifier only effect to the above 18GHz signal and no filter added to the measurement chain.



SPURIOUS EMISSIONS (HIGH CHANNEL, VERTICAL)

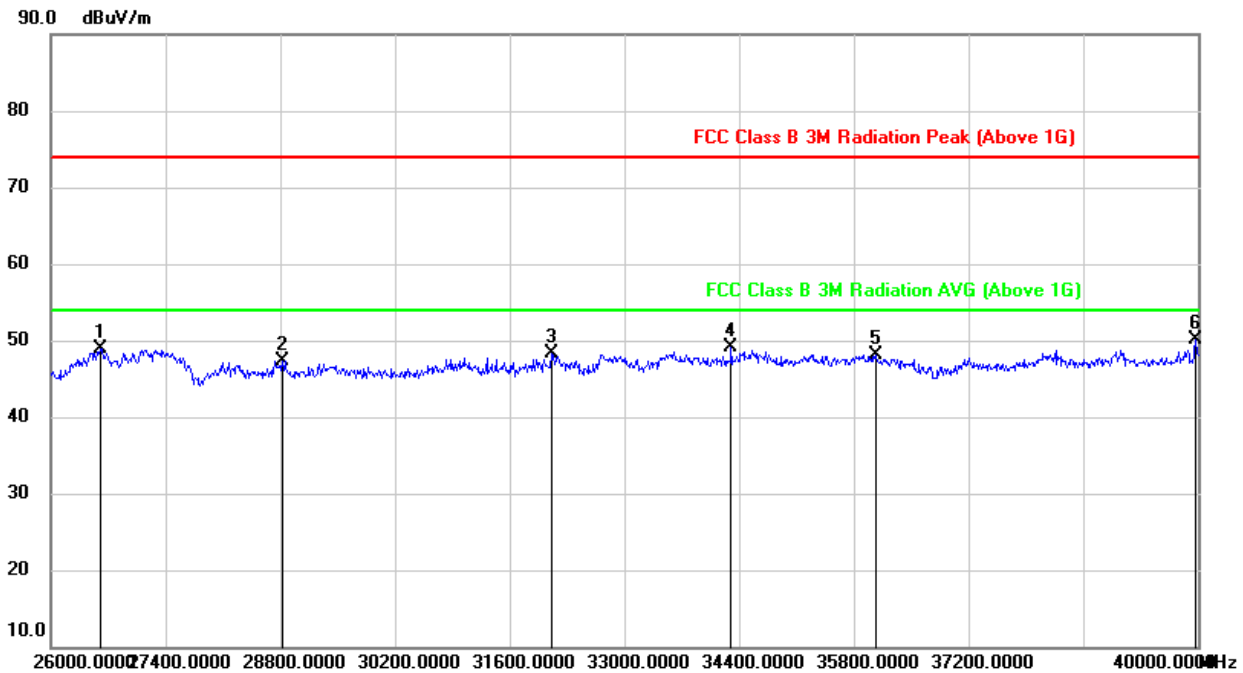

No.	Frequency (MHz)	Reading (dBuV)	Correct (dB/m)	Result (dBuV/m)	Limit (dBuV/m)	Margin (dB)	Remark
1	26602.000	53.78	-4.80	48.98	74.00	-25.02	peak
2	28828.000	48.13	-0.79	47.34	74.00	-26.66	peak
3	32104.000	49.99	-1.75	48.24	74.00	-25.76	peak
4	34302.000	47.95	1.10	49.05	74.00	-24.95	peak
5	36066.000	44.35	3.83	48.18	74.00	-25.82	peak
6	39972.000	44.95	5.13	50.08	74.00	-23.92	peak

Note: 1. Measurement = Reading Level + Correct Factor.
 2. If Peak Result complies with AV limit, AV Result is deemed to comply with AV limit.
 3. Peak: Peak detector.
 4. The preamplifier only effect to the above 18GHz signal and no filter added to the measurement chain.

Note: All antennas and test modes have been tested, only the worst data record in the report.

7.7. SPURIOUS EMISSIONS 30MHz ~ 1 GHz

7.7.1. 802.11HT20 LOW MODE

(WORST-CASE CONFIGURATION)

SPURIOUS EMISSIONS (LOW CHANNEL HORIZONTAL)

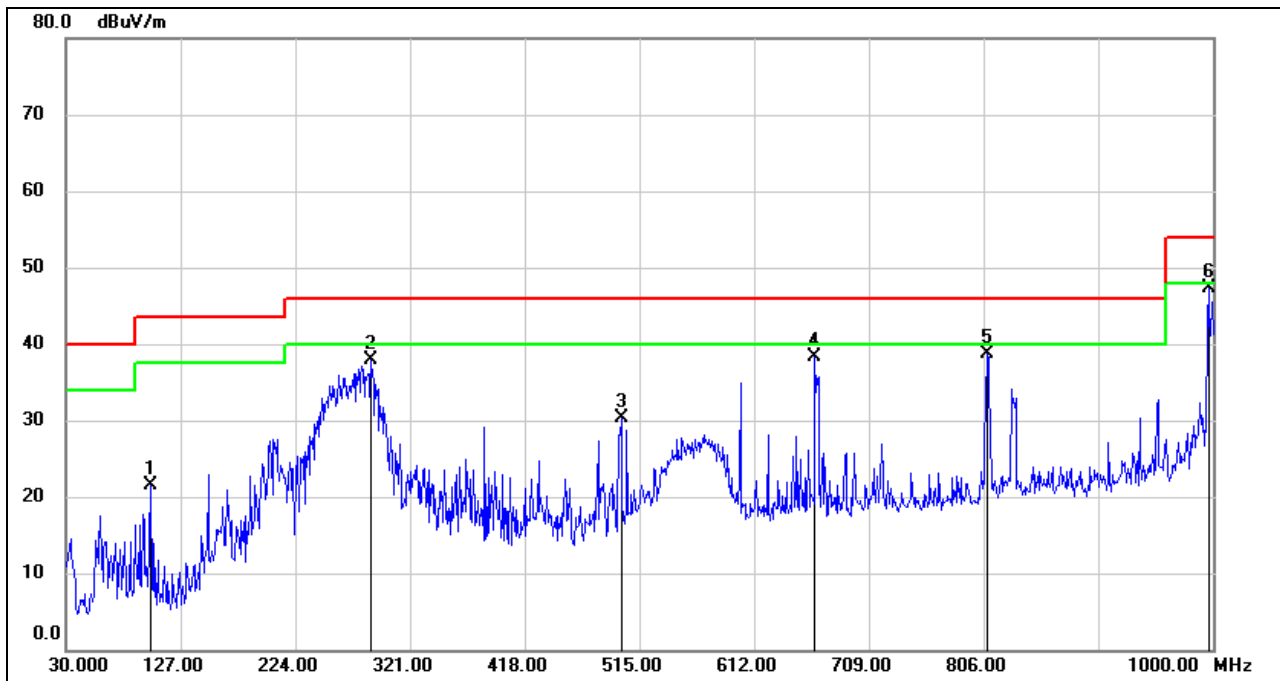

No.	Frequency (MHz)	Reading (dBuV)	Correct (dB/m)	Result (dBuV/m)	Limit (dBuV/m)	Margin (dB)	Remark
1	101.7800	43.30	-21.75	21.55	43.50	-21.95	QP
2	288.0200	52.50	-14.50	38.00	46.00	-8.00	QP
3	499.4800	40.98	-10.61	30.37	46.00	-15.63	QP
4	663.4099	45.60	-7.27	38.33	46.00	-7.67	QP
5	808.9099	43.98	-5.27	38.71	46.00	-7.29	QP
6	996.1200	50.18	-2.93	47.25	54.00	-6.75	QP

- Note: 1. Result Level = Read Level + Correct Factor.
 2. If Peak Result complies with QP limit, QP Result is deemed to comply with QP limit.
 3. Test setup: RBW: 120 kHz, VBW: 300 kHz, Sweep time: auto.



SPURIOUS EMISSIONS (LOW CHANNEL VERTICAL)

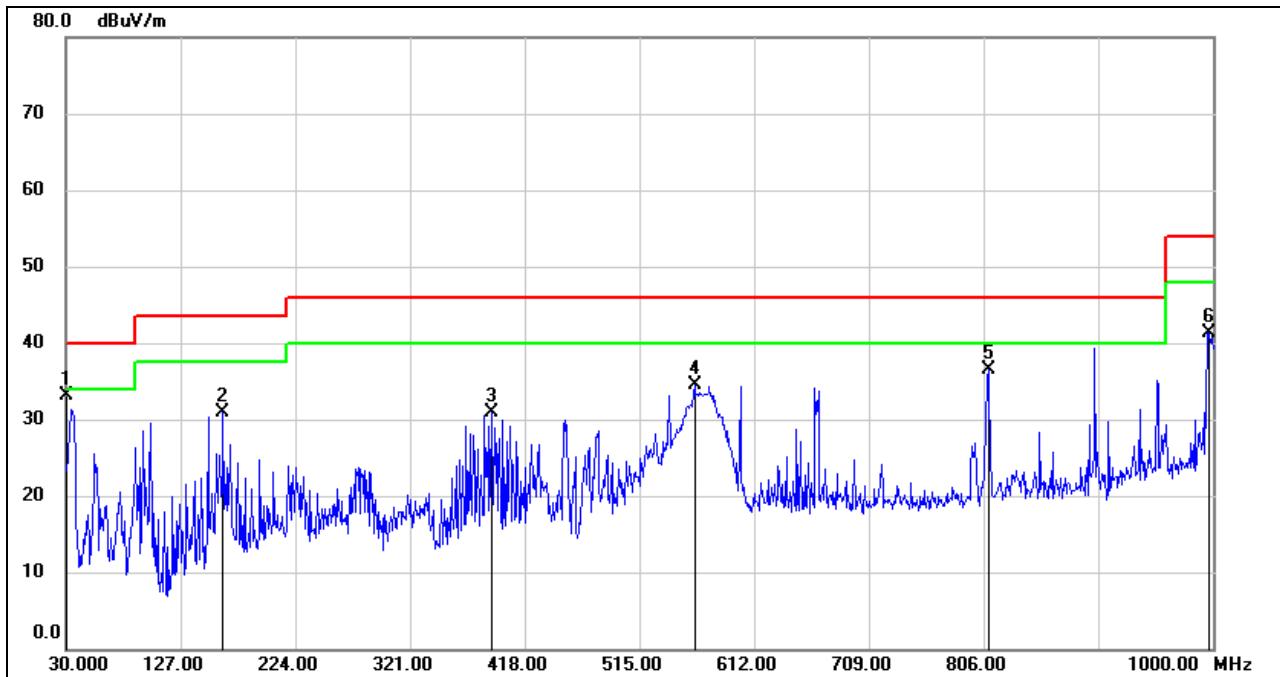

No.	Frequency (MHz)	Reading (dBuV)	Correct (dB/m)	Result (dBuV/m)	Limit (dBuV/m)	Margin (dB)	Remark
1	30.0000	50.08	-17.00	33.08	40.00	-6.92	QP
2	162.8900	48.46	-17.62	30.84	43.50	-12.66	QP
3	389.8700	43.48	-12.51	30.97	46.00	-15.03	QP
4	561.5600	43.80	-9.26	34.54	46.00	-11.46	QP
5	809.8800	41.68	-5.27	36.41	46.00	-9.59	QP
6	997.0900	44.28	-2.90	41.38	54.00	-12.62	QP

- Note: 1. Result Level = Read Level + Correct Factor.
 2. If Peak Result complies with QP limit, QP Result is deemed to comply with QP limit.
 3. Test setup: RBW: 120 kHz, VBW: 300 kHz, Sweep time: auto.

Note: All the test modes has been tested, only the worst data record in the report



7.8. SPURIOUS EMISSIONS BELOW 30MHz

7.8.1. 802.11HT 20 LOW MODE

(WORST-CASE CONFIGURATION)

SPURIOUS EMISSIONS (LOW CHANNEL HORIZONTAL)

9kHz~ 150kHz

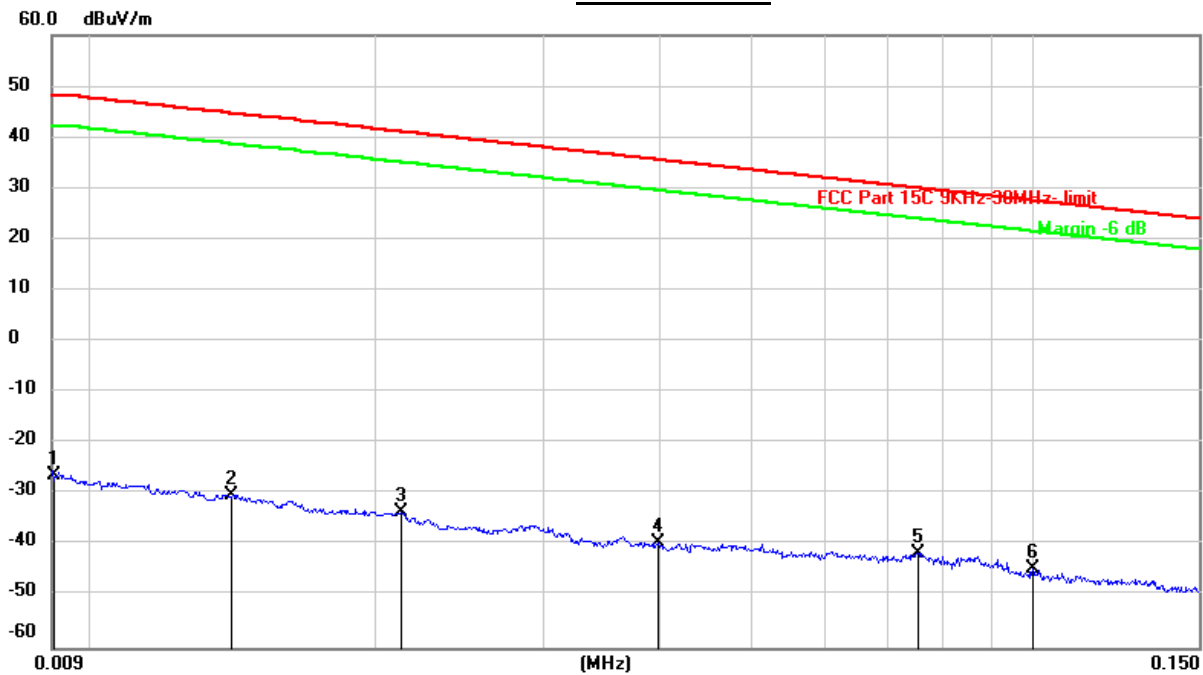

No.	Frequency (MHz)	Reading (dBuV)	Correct (dB/m)	Result (dBuV/m)	Limit (dBuV/m)	Margin (dB)	Remark
1	0.0091	75.08	-101.33	-26.25	48.28	-74.53	peak
2	0.0140	71.25	-101.38	-30.13	44.68	-74.81	peak
3	0.0212	68.04	-101.35	-33.31	41.07	-74.38	peak
4	0.0398	61.86	-101.43	-39.57	35.60	-75.17	peak
5	0.0752	60.15	-101.59	-41.44	30.08	-71.52	peak
6	0.1000	57.17	-101.80	-44.63	27.60	-72.23	peak

Note: 1. Measurement = Reading Level + Correct Factor.

2. If Peak Result complies with AV and QP limit, AV and QP Result are deemed to comply with AV limit.

3. All 3 polarizations(Horizontal, Face-on and Face-off) of the loop antenna had been tested, but only the worst data recorded in the report.



150KHz ~ 490KHz

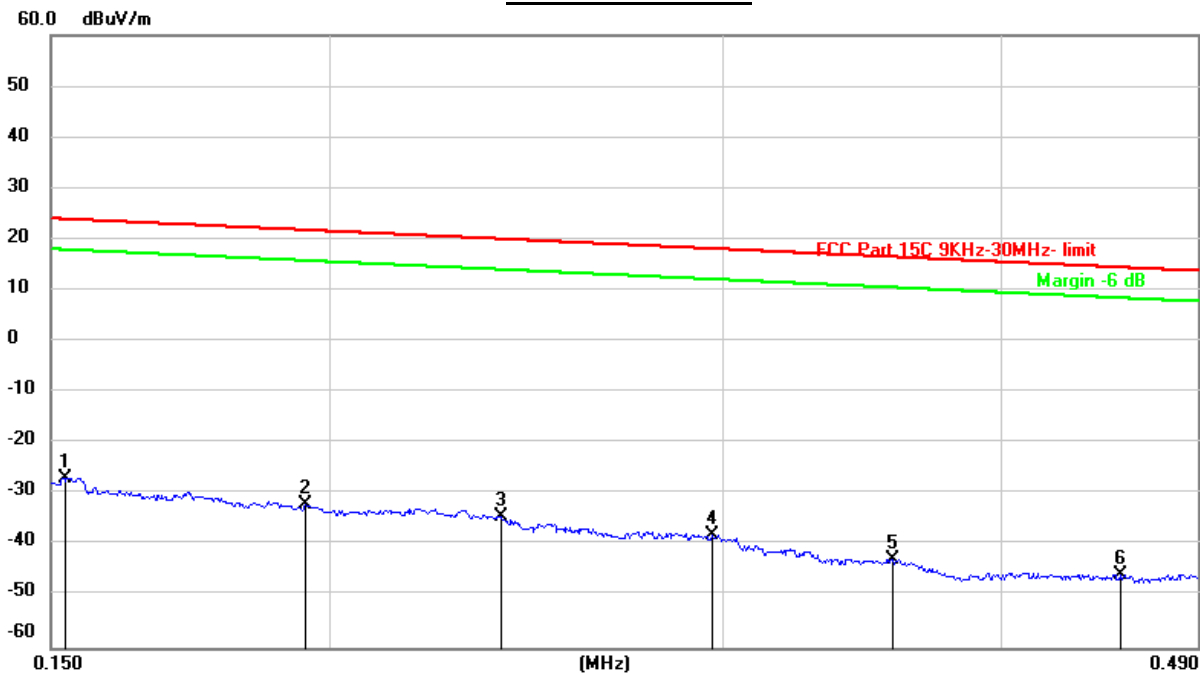

No.	Frequency (MHz)	Reading (dBuV)	Correct (dB/m)	Result (dBuV/m)	Limit (dBuV/m)	Margin (dB)	Remark
1	0.1524	74.80	-101.63	-26.83	23.94	-50.77	peak
2	0.1952	69.81	-101.71	-31.90	21.79	-53.69	peak
3	0.2389	67.39	-101.78	-34.39	20.04	-54.43	peak
4	0.2968	63.83	-101.85	-38.02	18.15	-56.17	peak
5	0.3577	59.19	-101.91	-42.72	16.53	-59.25	peak
6	0.4521	56.31	-102.01	-45.70	14.50	-60.20	peak

- Note: 1. Measurement = Reading Level + Correct Factor.
 2. If Peak Result complies with AV and QP limit, AV and QP Result are deemed to comply with AV limit.
 3. All 3 polarizations(Horizontal, Face-on and Face-off) of the loop antenna had been tested, but only the worst data recorded in the report.



490KHz~ 30MHz

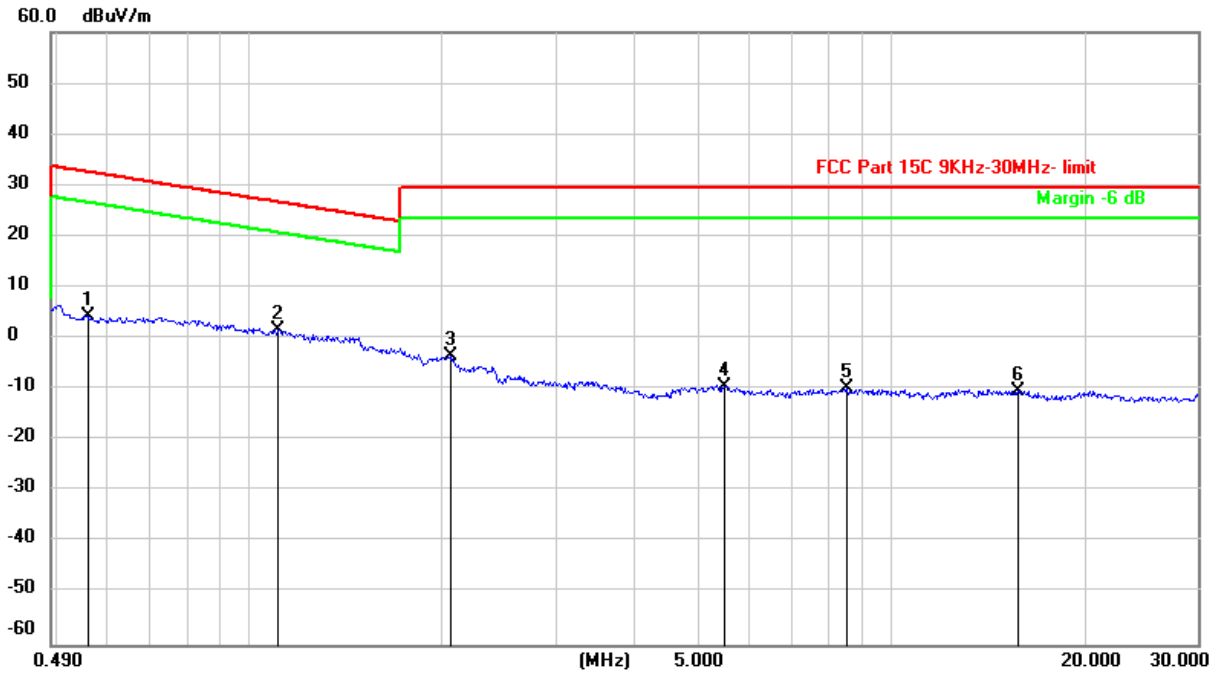

No.	Frequency (MHz)	Reading (dBuV)	Correct (dB/m)	Result (dBuV/m)	Limit (dBuV/m)	Margin (dB)	Remark
1	0.5590	66.37	-62.09	4.28	32.66	-28.38	peak
2	1.1088	63.82	-62.22	1.60	26.71	-25.11	peak
3	2.0598	58.26	-61.81	-3.55	29.54	-33.09	peak
4	5.5066	51.89	-61.42	-9.53	29.54	-39.07	peak
5	8.5462	51.19	-61.00	-9.81	29.54	-39.35	peak
6	15.7759	50.75	-60.99	-10.24	29.54	-39.78	peak

- Note: 1. Measurement = Reading Level + Correct Factor.
 2. If Peak Result complies with AV and QP limit, AV and QP Result are deemed to comply with AV limit.
 3. All 3 polarizations(Horizontal, Face-on and Face-off) of the loop antenna had been tested, but only the worst data recorded in the report.

Note: All the test modes have been tested, only the worst data record in the report.

8. AC POWER LINE CONDUCTED EMISSIONS

LIMITS

Please refer to CFR 47 FCC §15.207 (a) and ISED RSS-Gen Clause 8.8

FREQUENCY (MHz)	Class A (dBuV)		Class B (dBuV)	
	Quasi-peak	Average	Quasi-peak	Average
0.15 -0.5	79.00	66.00	66 - 56 *	56 - 46 *
0.50 -5.0	73.00	60.00	56.00	46.00
5.0 -30.0	73.00	60.00	60.00	50.00

TEST SETUP AND PROCEDURE

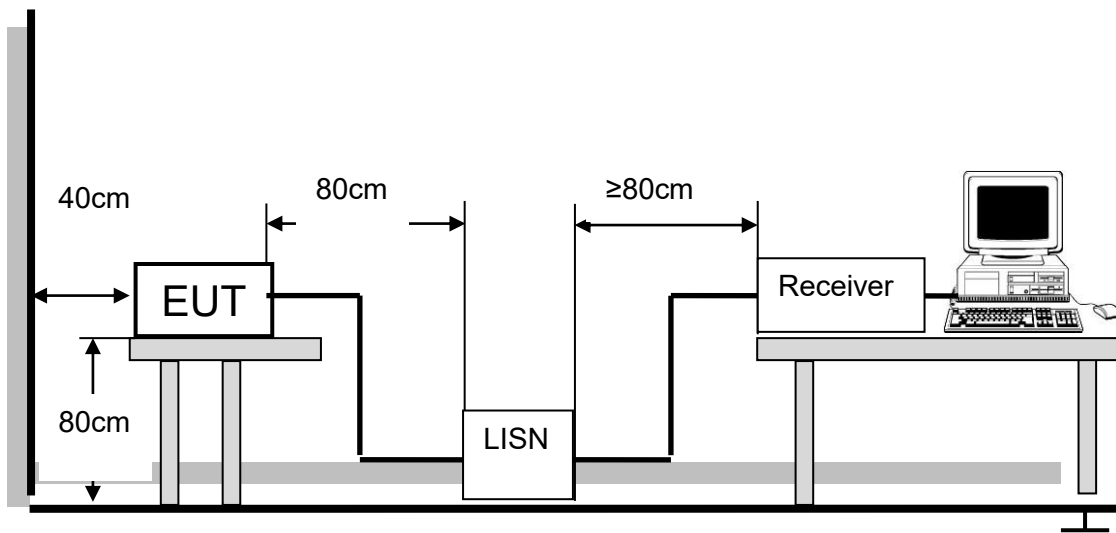

The EUT is put on a table of non-conducting material that is 80cm high. The vertical conducting wall of shielding is located 40cm to the rear of the EUT. The power line of the EUT is connected to the AC mains through an Artificial Mains Network (A.M.N.). A EMI Measurement Receiver (R&S Test Receiver ESR3) is used to test the emissions from both sides of AC line. According to the requirements in Section 6.2 of ANSI C63.10 -2013. Conducted emissions from the EUT measured in the frequency range between 0.15 MHz and 30MHz using CISPR Quasi-Peak and average detector mode. The bandwidth of EMI test receiver is set at 9kHz.

The arrangement of the equipment is installed to meet the standards and operating in a manner, which tends to maximize its emission characteristics in a normal application.

TEST ENVIRONMENT

Temperature	24.1°C	Relative Humidity	50%
Atmosphere Pressure	101kPa	Test Voltage	AC 120V_60Hz



TEST RESULTS

8.1. 802.11n20 LOW CHANNEL MODE (WORST-CASE CONFIGURATION)

LINE N RESULTS (LOW CHANNEL)

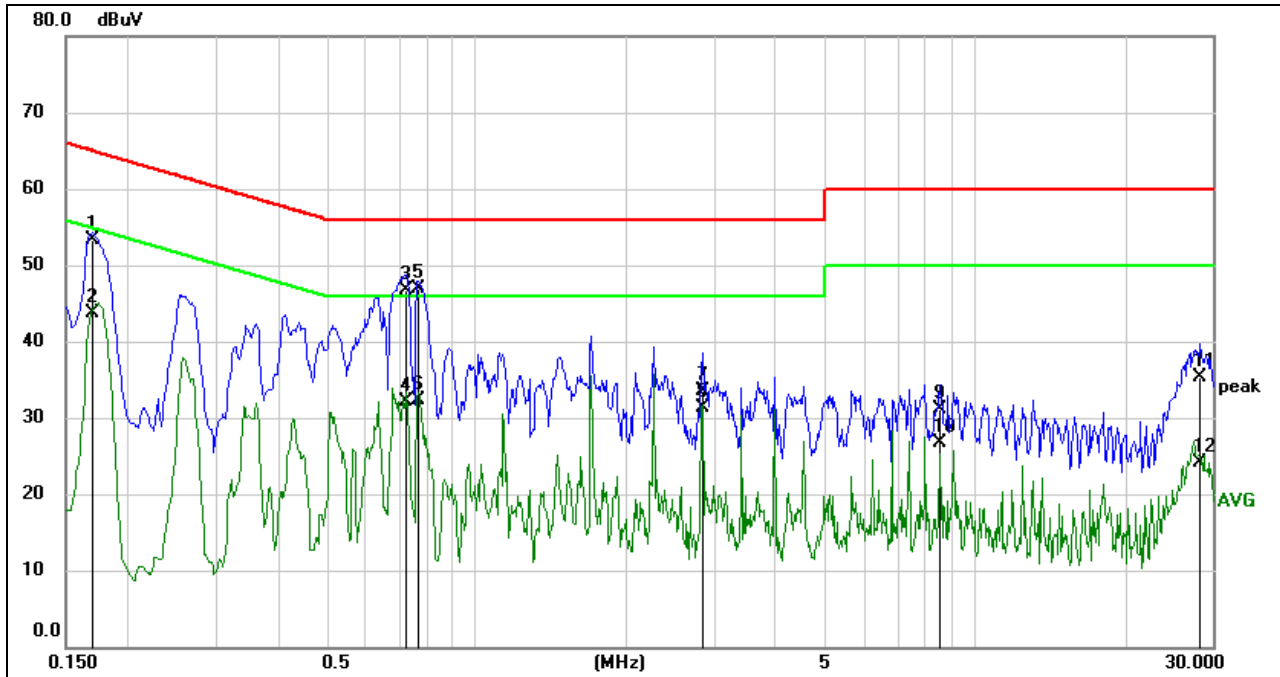

No.	Frequency (MHz)	Reading (dBuV)	Correct (dB)	Result (dBuV)	Limit (dBuV)	Margin (dB)	Remark
1	0.1695	43.68	9.60	53.28	64.98	-11.70	QP
2	0.1695	34.07	9.60	43.67	54.98	-11.31	AVG
3	0.7205	37.13	9.60	46.73	56.00	-9.27	QP
4	0.7205	22.44	9.60	32.04	46.00	-13.96	AVG
5	0.7666	37.37	9.60	46.97	56.00	-9.03	QP
6	0.7666	22.63	9.60	32.23	46.00	-13.77	AVG
7	2.8408	23.86	9.65	33.51	56.00	-22.49	QP
8	2.8408	21.63	9.65	31.28	46.00	-14.72	AVG
9	8.5209	21.37	9.74	31.11	60.00	-28.89	QP
10	8.5209	16.98	9.74	26.72	50.00	-23.28	AVG
11	28.4022	25.32	9.94	35.26	60.00	-24.74	QP
12	28.4022	14.08	9.94	24.02	50.00	-25.98	AVG

- Note: 1. Result = Reading +Correct Factor.
 2. If QP Result complies with AV limit, AV Result is deemed to comply with AV limit.
 3. Test setup: RBW: 200 Hz (9 kHz-150 kHz), 9 kHz (150 kHz-30 MHz).
 4. Step size: 80Hz (0.009MHz-0.15MHz), 4 kHz (0.15MHz-30MHz), Scan time: auto.

LINE L RESULTS (LOW CHANNEL)

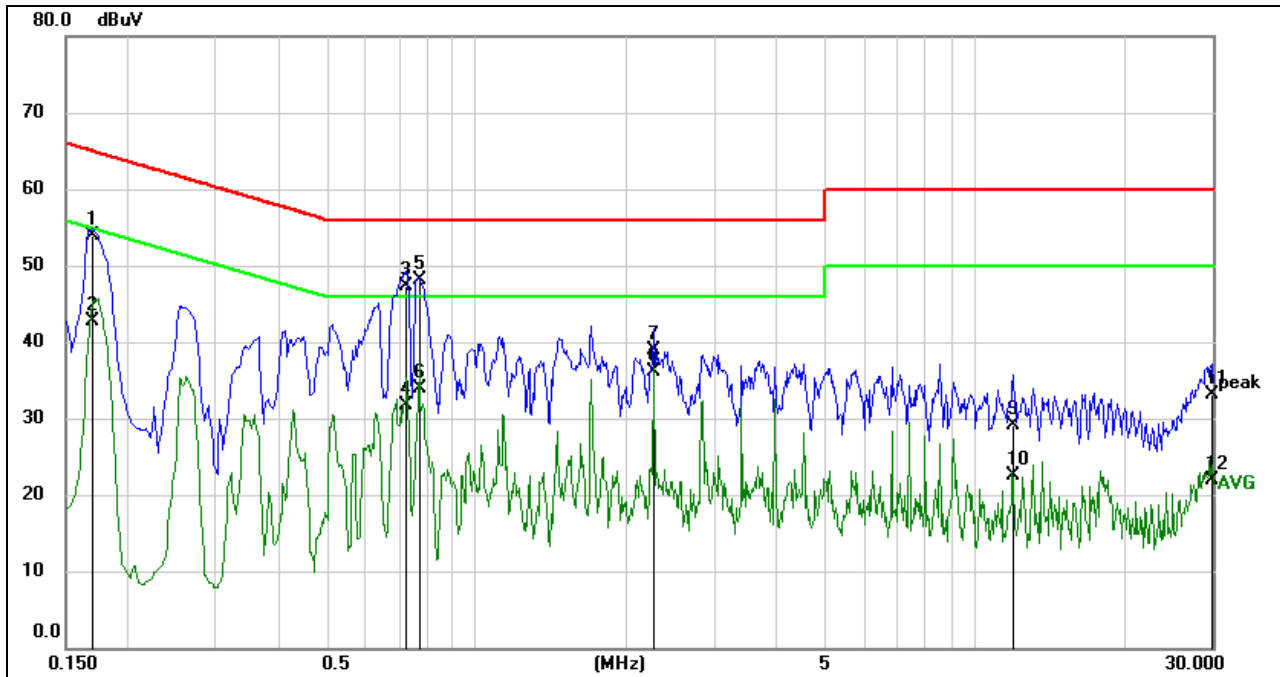

No.	Frequency (MHz)	Reading (dBuV)	Correct (dB)	Result (dBuV)	Limit (dBuV)	Margin (dB)	Remark
1	0.1694	44.33	9.61	53.94	64.99	-11.05	QP
2	0.1694	33.18	9.61	42.79	54.99	-12.20	AVG
3	0.7295	37.66	9.60	47.26	56.00	-8.74	QP
4	0.7295	22.09	9.60	31.69	46.00	-14.31	AVG
5	0.7679	38.49	9.61	48.10	56.00	-7.90	QP
6	0.7679	24.20	9.61	33.81	46.00	-12.19	AVG
7	2.2734	29.27	9.63	38.90	56.00	-17.10	QP
8	2.2734	26.55	9.63	36.18	46.00	-9.82	AVG
9	11.9346	19.37	9.78	29.15	60.00	-30.85	QP
10	11.9346	12.69	9.78	22.47	50.00	-27.53	AVG
11	29.9337	23.23	9.78	33.01	60.00	-26.99	QP
12	29.9337	12.05	9.78	21.83	50.00	-28.17	AVG

- Note: 1. Result = Reading +Correct Factor.
 2. If QP Result complies with AV limit, AV Result is deemed to comply with AV limit.
 3. Test setup: RBW: 200 Hz (9 kHz-150 kHz), 9 kHz (150 kHz-30 MHz).
 4. Step size: 80Hz (0.009MHz-0.15MHz), 4 kHz (0.15MHz-30MHz), Scan time: auto.

9. FREQUENCY STABILITY

LIMITS

The frequency of the carrier signal shall be maintained within band of operation

TEST SETUP AND PROCEDURE

Connect the UUT to the spectrum analyser and use the following settings:

Center Frequency	The center frequency of the channel under test
Detector	PEAK
RBW	10kHz
VBW	$\geq 3 \times \text{RBW}$
Span	Encompass the entire emissions bandwidth (EBW) of the signal
Trace	Max hold
Sweep time	Auto

Allow the trace to stabilize, find the peak value of the power envelope and record the frequency, then calculated the frequency drift.

The test extreme voltage is to change the primary supply voltage from 85 to 115 percent of the nominal value.

User manual temperature is $-20^{\circ}\text{C} \sim 40^{\circ}\text{C}$.

TEST SETUP

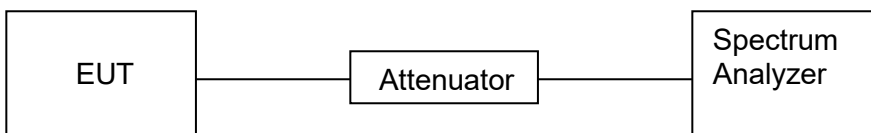

	Normal Test Conditions	Extreme Test Conditions
Temperature	TN(Normal Temperature): 25.5°C	TL(Low Temperature): -20°C
		TH(High Temperature): 40°C
Supply Voltage	VN(Normal Voltage): AC 120V_60Hz	VL(Low Voltage): AC 102V_60Hz
		VH(High Voltage): AC 138V_60Hz



TEST RESULTS

Frequency Error vs. Voltage									
802.11a:5200MHz									
Temp.	Volt.	0 Minute		2 Minute		5 Minute		10 Minute	
		Freq.Error (MHz)	Tolerance (ppm)	Freq.Error (MHz)	Tolerance (ppm)	Freq.Error (MHz)	Tolerance (ppm)	Freq.Error (MHz)	Tolerance (ppm)
TN	VL	5200.0189	3.63	5200.014	2.69	5200.0198	3.81	5200.0121	2.33
TN	VN	5200.0264	5.08	5200.0239	4.60	5200.0247	4.75	5200.0231	4.44
TN	VH	5200.0131	2.52	5200.0111	2.13	5200.0125	2.40	5200.0198	3.81

Frequency Error vs. Temperature									
802.11a:5200MHz									
Temp.	Volt.	0 Minute		2 Minute		5 Minute		10 Minute	
		Freq.Error (MHz)	Tolerance (ppm)	Freq.Error (MHz)	Tolerance (ppm)	Freq.Error (MHz)	Tolerance (ppm)	Freq.Error (MHz)	Tolerance (ppm)
40	VN	5200.0199	3.83	5200.0191	3.67	5200.0121	2.33	5200.0195	3.75
30	VN	5200.0164	3.15	5200.0167	3.21	5200.0223	4.29	5200.0161	3.10
20	VN	5200.0132	2.54	5200.0154	2.96	5200.0194	3.73	5200.0159	3.06
10	VN	5200.0193	3.71	5200.0177	3.40	5200.0155	2.98	5200.0172	3.31
0	VN	5200.0203	3.90	5200.0212	4.08	5200.0202	3.88	5200.0217	4.17
-10	VN	5200.0188	3.62	5200.0181	3.48	5200.0179	3.44	5200.0184	3.54
-20	VN	5200.0162	3.12	5200.0167	3.21	5200.0151	2.90	5200.0168	3.23

Note : All the modulation and channels had been tested, but only the worst data recorded in the report.

10. DYNAMIC FREQUENCY SELECTION

APPLICABILITY OF DFS REQUIREMENTS

Table 1: Applicability of DFS Requirements Prior to Use of a Channel

Requirement	Operational Mode		
	<input type="checkbox"/> Master	<input checked="" type="checkbox"/> Client Without Radar Detection	<input type="checkbox"/> Client With Radar Detection
Non-Occupancy Period	Yes	Not required	Yes
DFS Detection Threshold	Yes	Not required	Yes
Channel Availability Check Time	Yes	Not required	Not required
U-NII Detection Bandwidth	Yes	Not required	Yes

Table 2: Applicability of DFS requirements during normal operation

Requirement	Operational Mode	
	<input type="checkbox"/> Master Device or Client with Radar Detection	<input checked="" type="checkbox"/> Client Without Radar Detection
DFS Detection Threshold	Yes	Not required
Channel Closing Transmission Time	Yes	Yes
Channel Move Time	Yes	Yes
U-NII Detection Bandwidth	Yes	Not required

Additional requirements for devices with multiple bandwidth modes	<input type="checkbox"/> Master Device or Client with Radar Detection	<input checked="" type="checkbox"/> Client Without Radar Detection
U-NII Detection Bandwidth and Statistical Performance Check	All BW modes must be tested	Not required
Channel Move Time and Channel Closing Transmission Time	Test using widest BW mode available	Test using the widest BW mode available for the link
All other tests	Any single BW mode	Not required

Note: Frequencies selected for statistical performance check should include several frequencies within the radar detection bandwidth and frequencies near the edge of the radar detection bandwidth. For 802.11 devices it is suggested to select frequencies in each of the bonded 20 MHz channels and the channel center frequency.

LIMITS

(1) DFS Detection Thresholds

Table 3: DFS Detection Thresholds for Master Devices and Client Devices With Radar Detection

Maximum Transmit Power	Value (See Notes 1, 2, and 3)
EIRP \geq 200 milliwatt	-64 dBm
EIRP < 200 milliwatt and power spectral density < 10 dBm/MHz	-62 dBm
EIRP < 200 milliwatt that do not meet the power spectral density requirement	-64 dBm

Note 1: This is the level at the input of the receiver assuming a 0 dBi receive antenna.
 Note 2: Throughout these test procedures an additional 1 dB has been added to the amplitude of the test transmission waveforms to account for variations in measurement equipment. This will ensure that the test signal is at or above the detection threshold level to trigger a DFS response.
 Note3: EIRP is based on the highest antenna gain. For MIMO devices refer to KDB Publication 662911 D01.

(2) DFS Response Requirements

Table 4: DFS Response Requirement Values

Parameter	Value
Non-occupancy period	Minimum 30 minutes
Channel Availability Check Time	60 seconds
Channel Move Time	10 seconds See Note 1.
Channel Closing Transmission Time	200 milliseconds + an aggregate of 60 milliseconds over remaining 10 second period. See Notes 1 and 2.
U-NII Detection Bandwidth	Minimum 100% of the U-NII 99% transmission power bandwidth. See Note 3.

Note 1: Channel Move Time and the Channel Closing Transmission Time should be performed with Radar Type 0. The measurement timing begins at the end of the Radar Type 0 burst.
 Note 2: The Channel Closing Transmission Time is comprised of 200 milliseconds starting at the beginning of the Channel Move Time plus any additional intermittent control signals required facilitating a Channel move (an aggregate of 60 milliseconds) during the remainder of the 10 second period. The aggregate duration of control signals will not count quiet periods in between transmissions.
 Note 3: During the U-NII Detection Bandwidth detection test, radar type 0 should be used. For each frequency step the minimum percentage of detection is 90 percent. Measurements are performed with no data traffic.



PARAMETERS OF RADAR TEST WAVEFORMS

This section provides the parameters for required test waveforms, minimum percentage of successful detections, and the minimum number of trials that must be used for determining DFS conformance. Step intervals of 0.1 microsecond for Pulse Width, 1 microsecond for PRI, 1 MHz for chirp width and 1 for the number of pulses will be utilized for the random determination of specific test waveforms.

Table 5 Short Pulse Radar Test Waveforms

Radar Type	Pulse Width (µsec)	PRI (µsec)	Number of Pulses	Minimum Percentage of Successful Detection	Minimum Number of Trials
0	1	1428	18	See Note 1	See Note 1
1	1	Test A	Roundup $\left\lceil \frac{1}{\left(\frac{360}{\text{PRI}_{\mu\text{sec}}}\right)} \right\rceil$	60%	30
		Test B			
2	1-5	150-230	23-29	60%	30
3	6-10	200-500	16-18	60%	30
4	11-20	200-500	12-16	60%	30
Aggregate (Radar Types 1-4)				80%	120
Note 1: Short Pulse Radar Type 0 should be used for the detection bandwidth test, channel move time, and channel closing time tests. Test A: 15 unique PRI values randomly selected from the list of 23 PRI values in Table 5a. Test B: 15 unique PRI values randomly selected within the range of 518-3066 µsec, with a minimum increment of 1 µsec, excluding PRI values selected in Test A					

A minimum of 30 unique waveforms are required for each of the Short Pulse Radar Types 2 through 4. If more than 30 waveforms are used for Short Pulse Radar Types 2 through 4, then each additional waveform must also be unique and not repeated from the previous waveforms. If more than 30 waveforms are used for Short Pulse Radar Type 1, then each additional waveform is generated with Test B and must also be unique and not repeated from the previous waveforms in Tests A or B. Test aggregate is average of the percentage of successful detections of short pulse radar types 1-4

TEST SETUP

Setup for Client with injection at the Master

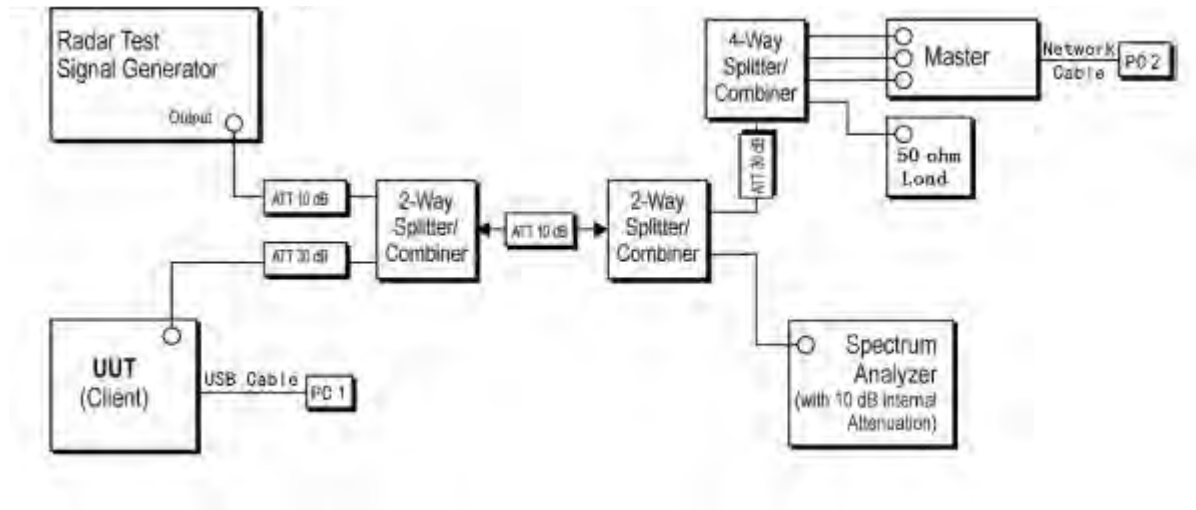

DFS Detection Threshold levels

DFS Threshold Level:-62.09 dBm

The Interference **Radar Detection Threshold Level** is -62dBm. That have been taken into account the master output power range and antenna gain.

Radar Type 0 (80MHz / 5290MHz)

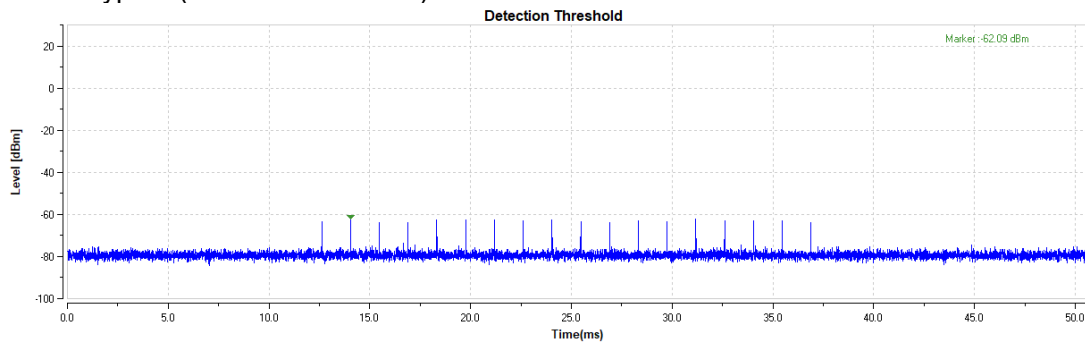



Test Data

BW/Channel	Test Item	Test Result	Limit	Results
80MHz / 5530MHz	Channel Move Time	0.512S	< 10 s	pass
	Channel Closing Transmission Time	0.003S	200 milliseconds + an aggregate of 60 milliseconds over remaining 10 second period.	pass

Test plots as follows:

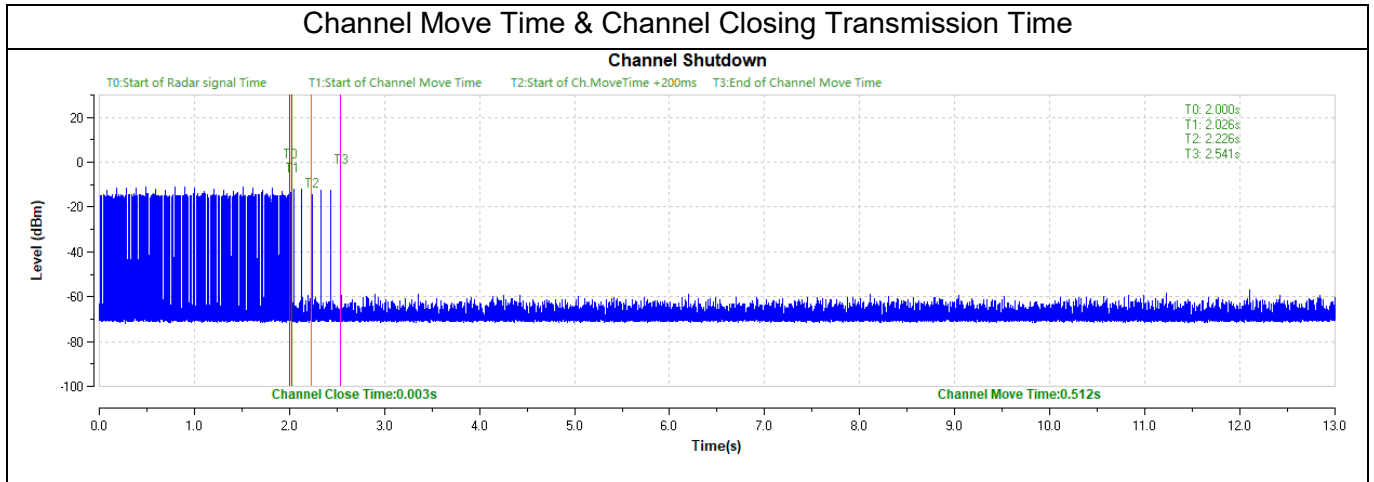



11. ANTENNA REQUIREMENTS

APPLICABLE REQUIREMENTS

Please refer to FCC §15.203

An intentional radiator shall be designed to ensure that no antenna other than that furnished by the responsible party shall be used with the device. The use of a permanently attached antenna or of an antenna that uses a unique coupling to the intentional radiator shall be considered sufficient to comply with the provisions of this section. The manufacturer may design the unit so that a broken antenna can be replaced by the user, but the use of a standard antenna jack or electrical connector is prohibited.

Please refer to FCC §15.247(b)(4)

The conducted output power limit specified in paragraph (b) of this section is based on the use of antennas with directional gains that do not exceed 6 dBi. Except as shown in paragraph (c) of this section, if transmitting antennas of directional gain greater than 6 dBi are used, the conducted output power from the intentional radiator shall be reduced below the stated values in paragraphs (b)(1), (b)(2), and (b)(3) of this section, as appropriate, by the amount in dB that the directional gain of the antenna exceeds 6 dBi.

RESULTS

Complies

END OF REPORT