



**CFR 47 FCC PART 15 SUBPART C
ISED RSS-247 ISSUE 2**

TEST REPORT

For

Acuity Brands – Juno AI

MODEL NUMBER: J6AIALXA DB, J6AIALXA DC, J6AISPKR DB, J6AISPKR DC

**FCC ID: 2ADCB-J6AIALXA
IC: 6715C-J6AIALXA**

REPORT NUMBER: 4789053728.1-3

ISSUE DATE: October 14, 2019

Prepared for

**Acuity Brands Lighting, Inc.
One Lithonia Way, Conyers, GA 30012**

Prepared by

**UL Verification Services (Guangzhou) Co., Ltd, Song Shan Lake Branch
Building 10, Innovation Technology Park, No. 1, Li Bin Road, Song Shan Lake
Hi-Tech Development Zone Dongguan, People's Republic of China**

Tel: +86 769 22038881

Fax: +86 769 33244054

Website: www.ul.com



Revision History

<u>Rev.</u>	<u>Issue Date</u>	<u>Revisions</u>	<u>Revised By</u>
V0	10/14/2019	Initial Issue	



Summary of Test Results			
Clause	Test Items	FCC/ISED Rules	Test Results
1	6dB Bandwidth and 99% Occupied Bandwidth	FCC Part 15.247 (a) (2) RSS-247 Clause 5.2 (a) ISED RSS-Gen Clause 6.7	Pass
2	Peak Conducted Output Power	FCC Part 15.247 (b) (3) RSS-247 Clause 5.4 (d)	Pass
3	Power Spectral Density	FCC Part 15.247 (e) RSS-247 Clause 5.2 (b)	Pass
4	Conducted Bandedge and Spurious Emission	FCC Part 15.247 (d) RSS-247 Clause 5.5	Pass
5	Radiated Bandedge and Spurious Emission	FCC Part 15.247 (d) FCC Part 15.209 FCC Part 15.205 RSS-247 Clause 5.5 RSS-GEN Clause 8.9	Pass
6	Conducted Emission Test For AC Power Port	FCC Part 15.207 RSS-GEN Clause 8.8	Pass
7	Antenna Requirement	FCC Part 15.203 RSS-GEN Clause 6.8	Pass
Note: This test report is only published to and used by the applicant, and it is not for evidence purpose in China.			



TABLE OF CONTENTS

1. ATTESTATION OF TEST RESULTS	6
2. TEST METHODOLOGY	7
3. FACILITIES AND ACCREDITATION	7
4. CALIBRATION AND UNCERTAINTY	8
4.1. <i>MEASURING INSTRUMENT CALIBRATION</i>	<i>8</i>
4.2. <i>MEASUREMENT UNCERTAINTY</i>	<i>8</i>
5. EQUIPMENT UNDER TEST	9
5.1. <i>DESCRIPTION OF EUT</i>	<i>9</i>
5.2. <i>MAXIMUM OUTPUT POWER.....</i>	<i>9</i>
5.3. <i>CHANNEL LIST</i>	<i>9</i>
5.4. <i>TEST CHANNEL CONFIGURATION.....</i>	<i>10</i>
5.5. <i>THE WORSE CASE POWER SETTING PARAMETER.....</i>	<i>10</i>
5.6. <i>THE WORSE CASE CONFIGURATIONS.....</i>	<i>10</i>
5.7. <i>DESCRIPTION OF AVAILABLE ANTENNAS</i>	<i>11</i>
5.8. <i>DESCRIPTION OF TEST SETUP.....</i>	<i>12</i>
6. MEASURING INSTRUMENT AND SOFTWARE USED	13
7. MEASUREMENT METHODS	14
8. ANTENNA PORT TEST RESULTS	15
8.1. <i>ON TIME AND DUTY CYCLE</i>	<i>15</i>
8.2. <i>6 dB DTS BANDWIDTH AND 99% OCCUPIED BANDWIDTH</i>	<i>18</i>
8.2.1. <i>802.11b MODE</i>	<i>19</i>
8.2.2. <i>802.11g MODE</i>	<i>23</i>
8.2.3. <i>802.11n HT20 MODE</i>	<i>27</i>
8.3. <i>PEAK CONDUCTED OUTPUT POWER.....</i>	<i>31</i>
8.3.1. <i>802.11b MODE</i>	<i>32</i>
8.3.2. <i>802.11g MODE</i>	<i>32</i>
8.3.3. <i>802.11n HT20 MODE</i>	<i>32</i>
8.4. <i>POWER SPECTRAL DENSITY</i>	<i>33</i>
8.5. <i>CONDUCTED BANDEDGE AND SPURIOUS EMISSIONS.....</i>	<i>35</i>
9. RADIATED TEST RESULTS.....	37
9.1. <i>RESTRICTED BANDEDGE</i>	<i>43</i>
9.1.1. <i>802.11b MODE</i>	<i>43</i>
9.1.2. <i>802.11g MODE</i>	<i>51</i>
9.1.3. <i>802.11n HT20 MODE</i>	<i>59</i>



9.2.	<i>SPURIOUS EMISSIONS (3~18GHz)</i>	67
9.2.1.	802.11b MODE	67
9.2.2.	802.11g MODE	74
9.2.3.	802.11n HT20 MODE	81
9.3.	<i>SPURIOUS EMISSIONS (1~3GHz)</i>	87
9.3.1.	802.11b MODE	87
9.3.2.	802.11g MODE	93
9.3.3.	802.11n HT20 MODE	99
9.4.	<i>SPURIOUS EMISSIONS (18~26GHz)</i>	105
9.4.1.	802.11b MODE	105
9.5.	<i>SPURIOUS EMISSIONS (0.03 ~ 1 GHz)</i>	107
9.5.1.	802.11b MODE	107
9.6.	<i>SPURIOUS EMISSIONS BELOW 30M</i>	109
9.6.1.	802.11b MODE	109
10.	AC POWER LINE CONDUCTED EMISSIONS	112
10.1.	802.11b MODE.....	113
11.	ANTENNA REQUIREMENTS	115
	Appendix E): Band-edge for RF Conducted Emissions	116
	Appendix F): RF Conducted Spurious Emissions.....	120
	Appendix G): Maximum Power Spectral Density	134



1. ATTESTATION OF TEST RESULTS

Applicant Information

Company Name: Acuity Brands Lighting, Inc.
Address: One Lithonia Way, Conyers, GA 30012

Manufacturer Information

Company Name: Acuity Brands Lighting, Inc.
Address: One Lithonia Way, Conyers, GA 30012

EUT Information

EUT Name: Acuity Brands – Juno AI
Model: J6AIALXA DB
Series Model: J6AIALXA DC, J6AISPKR DB, J6AISPKR DC
Model Difference: See section 5.1 of this report for detail
Brand: Juno AI
Sample Status: Normal
Sample ID: 2524327
Sample Received Date: August 30, 2019
Date of Tested: September 5 ~ October 12, 2019

APPLICABLE STANDARDS	
STANDARD	TEST RESULTS
CFR 47 FCC PART 15 SUBPART C	PASS
ISED RSS-247 Issue 2	PASS
ISED RSS-GEN Issue 5	PASS

Prepared By:

Checked By:

Kebo Zhang
Engineer Project Associate

Shawn Wen
Laboratory Leader

Approved By:

Stephen Guo
Laboratory Manager



2. TEST METHODOLOGY

The tests documented in this report were performed in accordance with KDB 558074 D01 15.247 Meas Guidance v05r02, 414788 D01 Radiated Test Site v01r01, CFR 47 FCC Part 2, CFR 47 FCC Part 15, ANSI C63.10-2013, ISED RSS-247 Issue 2 and ISED RSS-GEN Issue 5.

3. FACILITIES AND ACCREDITATION

Accreditation Certificate	<p>A2LA (Certificate No.: 4102.01) UL Verification Services (Guangzhou) Co., Ltd. Song Shan Lake Branch. has been assessed and proved to be in compliance with A2LA.</p> <p>FCC (FCC Designation No.: CN1187) UL Verification Services (Guangzhou) Co., Ltd. Song Shan Lake Branch. Has been recognized to perform compliance testing on equipment subject to the Commission's Declaration of Conformity (DoC) and Certification rules</p> <p>ISED(Company No.: 21320) UL Verification Services (Guangzhou) Co., Ltd. Song Shan Lake Branch. has been registered and fully described in a report filed with ISED. The Company Number is 21320.</p> <p>VCCI (Registration No.: G-20019, R-20004, C-20012 and T-20011) UL Verification Services (Guangzhou) Co., Ltd. Song Shan Lake Branch. has been assessed and proved to be in compliance with VCCI, the Membership No. is 3793. Facility Name: Chamber D, the VCCI registration No. is G-20019 and R-20004 Shielding Room B , the VCCI registration No. is C-20012 and T-20011</p>
---------------------------	---

Note 1: All tests measurement facilities use to collect the measurement data are located at Building 10, Innovation Technology Park, Song Shan Lake Hi tech Development Zone, Dongguan, 523808, China

Note 2: The test anechoic chamber in UL Verification Services (Guangzhou) Co., Ltd. Song Shan Lake Branch had been calibrated and compared to the open field sites and the test anechoic chamber is shown to be equivalent to or worst case from the open field site.

Note 3: For below 30MHz, lab had performed measurements at test anechoic chamber and comparing to measurements obtained on an open field site. And these measurements below 30MHz had been correlated to measurements performed on an OFS.



4. CALIBRATION AND UNCERTAINTY

4.1. MEASURING INSTRUMENT CALIBRATION

The measuring equipment utilized to perform the tests documented in this report has been calibrated in accordance with the manufacturer's recommendations, and is traceable to recognize national standards.

4.2. MEASUREMENT UNCERTAINTY

Where relevant, the following measurement uncertainty levels have been estimated for tests performed on the apparatus:

Test Item	Uncertainty
Conduction emission	3.62dB
Radiation Emission test(include Fundamental emission) (9KHz-30MHz)	2.2dB
Radiation Emission test(include Fundamental emission) (30MHz-1GHz)	4.00dB
Radiation Emission test (1GHz to 26GHz)(include Fundamental emission)	5.78dB (1GHz-18Gz)
	5.23dB (18GHz-26Gz)
Note: This uncertainty represents an expanded uncertainty expressed at approximately the 95% confidence level using a coverage factor of k=2.	



5. EQUIPMENT UNDER TEST

5.1. DESCRIPTION OF EUT

Equipment	Acuity Brands – Juno AI
Model Name	J6AIALXA DB
Series Model	J6AIALXA DC, J6AISPKR DB, J6AISPKR DC
Model Difference	The J6AIALXA DB and J6AIALXA DC are the same full function device while J6AIALXA DB have plastic baffle decorative part installed and J6AIALXA DC have metal cone decorative part installed. The J6AISPKR DB and J6AISPKR DC are reduce function of J6AIALXA DB and J6AIALXA DC, it removed the microphone and LED indicator board from J6AIALXA DB and J6AIALXA DC while the other hardware same as design model.
Radio Technology	IEEE802.11b/g/n HT20
Operation frequency	IEEE 802.11b: 2412MHz—2462MHz IEEE 802.11g: 2412MHz—2462MHz IEEE 802.11n HT20: 2412MHz—2462MHz
Modulation	IEEE 802.11b: DSSS(CCK) IEEE 802.11g: OFDM(64QAM, 16QAM, QPSK, BPSK) IEEE 802.11n HT20: OFDM (64QAM, 16QAM, QPSK,BPSK)
Supply Voltage	AC 120V, 60Hz

5.2. MAXIMUM OUTPUT POWER

Number of Transmit Chains (NTX)	IEE Std. 802.11	Frequency (MHz)	Channel Number	Max PK Conducted Power (dBm)
1	IEEE 802.11b	2412-2462	1-11[11]	16.97
1	IEEE 802.11g	2412-2462	1-11[11]	20.10
1	IEEE 802.11nHT20	2412-2462	1-11[11]	19.20

5.3. CHANNEL LIST

Channel List for 802.11b/g/n (20 MHz)							
Channel	Frequency (MHz)	Channel	Frequency (MHz)	Channel	Frequency (MHz)	Channel	Frequency (MHz)
1	2412	4	2427	7	2442	10	2457
2	2417	5	2432	8	2447	11	2462
3	2422	6	2437	9	2452	/	/



5.4. TEST CHANNEL CONFIGURATION

Test Mode	Test Channel	Frequency
WiFi TX(802.11b)	CH 1, CH 6, CH 11/ Low, Middle, High	2412MHz, 2437MHz, 2462MHz
WiFi TX(802.11g)	CH 1, CH 6, CH 11/ Low, Middle, High	2412MHz, 2437MHz, 2462MHz
WiFi TX(802.11n HT20)	CH 1, CH 6, CH 11/ Low, Middle, High	2412MHz, 2437MHz, 2462MHz

5.5. THE WORSE CASE POWER SETTING PARAMETER

The Worse Case Power Setting Parameter under 2400 ~ 2483.5MHz Band							
Test Software		adb					
Modulation Mode	Transmit Antenna Number	NCB: 20MHz			NCB: 40MHz		
		CH 1	CH 6	CH 11	CH 3	CH 6	CH 9
802.11b	1	15	15	15	/		
802.11g	1	13	13	13			
802.11n HT20	1	12	12	12			

5.6. THE WORSE CASE CONFIGURATIONS

Worst-case data rates as provided by the client were:

- 802.11b mode: 1 Mbps
- 802.11b mode: 6 Mbps
- 802.11n HT20 mode: MCS0

Note: All models had been evaluated, and the worst model is J6AIALXA DB, only the worst data for J6AIALXA DB recorded in the report.



5.7. DESCRIPTION OF AVAILABLE ANTENNAS

Antenna	Frequency (MHz)	Antenna Type	MAX Antenna Gain (dBi)
1	2412-2462	IFA antenna	3.35

Test Mode	Transmit and Receive Mode	Description
IEEE 802.11b	<input checked="" type="checkbox"/> 1TX, 1RX	Antenna 1 can be used as transmitting/receiving antenna.
IEEE 802.11g	<input checked="" type="checkbox"/> 1TX, 1RX	Antenna 1 can be used as transmitting/receiving antenna.
IEEE 802.11n HT20	<input checked="" type="checkbox"/> 1TX, 1RX	Antenna 1 can be used as transmitting/receiving antenna.



5.8. DESCRIPTION OF TEST SETUP

SUPPORT EQUIPMENT

Item	Equipment	Brand Name	Model Name	P/N
1	PC	Dell	Vostro 3902	8KNDDDB2
2	USB TO UART	/	/	/

I/O CABLES

Cable No	Port	Connector Type	Cable Type	Cable Length(m)	Remarks
1	USB	/	/	1.0	/

ACCESSORIES

Item	Accessory	Brand Name	Model Name	Description
1	/	/	/	/

TEST SETUP

The EUT can work in engineering mode with a software through a Laptop.

SETUP DIAGRAM FOR TESTS

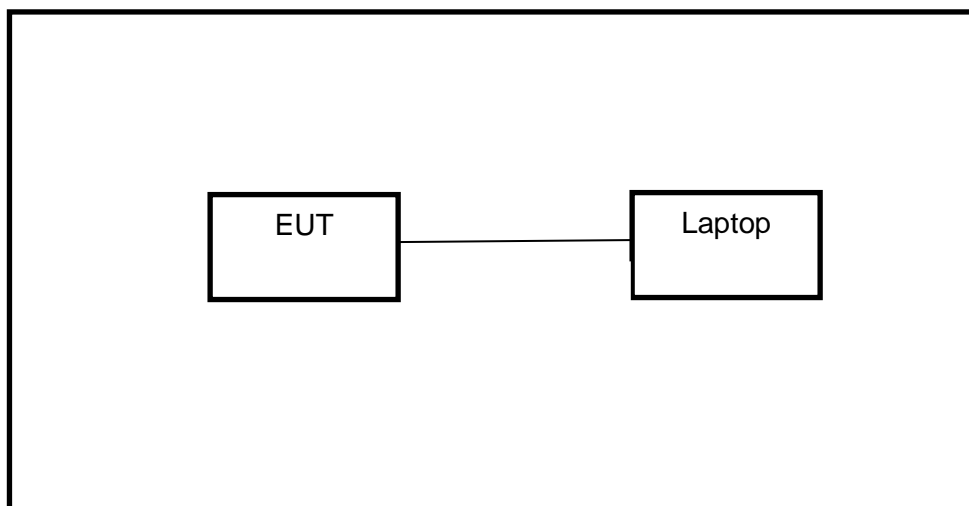



6. MEASURING INSTRUMENT AND SOFTWARE USED

Conducted Emissions						
Instrument						
Used	Equipment	Manufacturer	Model No.	Serial No.	Last Cal.	Next Cal.
<input checked="" type="checkbox"/>	EMI Test Receiver	R&S	ESR3	101961	Dec.10,2018	Dec.10,2019
<input checked="" type="checkbox"/>	Two-Line V-Network	R&S	ENV216	101983	Dec.10,2018	Dec.10,2019
<input checked="" type="checkbox"/>	Artificial Mains Networks	Schwarzbeck	NSLK 8126	8126465	Dec.10,2018	Dec.10,2019
Software						
Used	Description	Manufacturer	Name	Version		
<input checked="" type="checkbox"/>	Test Software for Conducted disturbance	Farad	EZ-EMC	Ver. UL-3A1		
Radiated Emissions						
Instrument						
Used	Equipment	Manufacturer	Model No.	Serial No.	Last Cal.	Next Cal.
<input checked="" type="checkbox"/>	MXE EMI Receiver	KESIGHT	N9038A	MY56400036	Dec.10,2018	Dec.10,2019
<input checked="" type="checkbox"/>	Hybrid Log Periodic Antenna	TDK	HLP-3003C	130960	Sep.17, 2018	Sep.17, 2021
<input checked="" type="checkbox"/>	Preamplifier	HP	8447D	2944A09099	Dec.10,2018	Dec.10,2019
<input checked="" type="checkbox"/>	EMI Measurement Receiver	R&S	ESR26	101377	Dec.10,2018	Dec.10,2019
<input checked="" type="checkbox"/>	Horn Antenna	TDK	HRN-0118	130939	Sep.17, 2018	Sep.17, 2021
<input checked="" type="checkbox"/>	High Gain Horn Antenna	Schwarzbeck	BBHA-9170	691	Aug.11, 2018	Aug.11, 2021
<input checked="" type="checkbox"/>	Preamplifier	TDK	PA-02-0118	TRS-305-00066	Dec.10,2018	Dec.10,2019
<input checked="" type="checkbox"/>	Preamplifier	TDK	PA-02-2	TRS-307-00003	Dec.10,2018	Dec.10,2019
<input checked="" type="checkbox"/>	Loop antenna	Schwarzbeck	1519B	00008	Jan.07, 2019	Jan.07, 2022
<input checked="" type="checkbox"/>	Band Reject Filter	Wainwright	WRCJV8-2350-2400-2483.5-2533.5-40SS	4	Dec.10,2018	Dec.10,2019
<input checked="" type="checkbox"/>	High Pass Filter	Wi	WHKX10-2700-3000-18000-40SS	23	Dec.10,2018	Dec.10,2019
Software						
Used	Description	Manufacturer	Name	Version		
<input checked="" type="checkbox"/>	Test Software for Radiated disturbance	Farad	EZ-EMC	Ver. UL-3A1		



Other instruments						
Used	Equipment	Manufacturer	Model No.	Serial No.	Last Cal.	Next Cal.
<input checked="" type="checkbox"/>	Spectrum Analyzer	Keysight	N9030A	MY55410512	Dec.10,2018	Dec.10,2019
<input checked="" type="checkbox"/>	Power Meter	Keysight	N1911A	MY55416024	Dec.10,2018	Dec.10,2019
<input checked="" type="checkbox"/>	Power Sensor	Keysight	U2021XA	MY5100022	Dec.10,2018	Dec.10,2019

7. MEASUREMENT METHODS

No.	Test Item	KDB Name	Section
1	6dB Bandwidth	KDB 558074 D01 15.247 Meas Guidance v05r02	8.2
2	Peak Output Power	KDB 558074 D01 15.247 Meas Guidance v05r02	8.3.1.3/8.3.2.3
3	Power Spectral Density	KDB 558074 D01 15.247 Meas Guidance v05r02	8.4
4	Out-of-band emissions in non-restricted bands	KDB 558074 D01 15.247 Meas Guidance v05r02	8.5
5	Out-of-band emissions in restricted bands	KDB 558074 D01 15.247 Meas Guidance v05r02	8.6
6	Band-edge	KDB 558074 D01 15.247 Meas Guidance v05r02	8.7
7	Conducted Emission Test For AC Power Port	ANSI C63.10-2013	6.2
8	99% Bandwidth	ANSI C63.10-2013	6.9.3



8. ANTENNA PORT TEST RESULTS

8.1. ON TIME AND DUTY CYCLE

LIMITS

None; for reporting purposes only

PROCEDURE

KDB 558074 Zero-Span Spectrum Analyzer Method

TEST SETUP

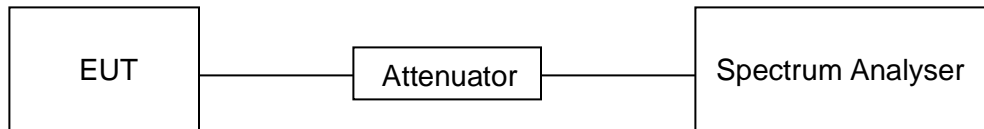

TEST ENVIRONMENT

Temperature	25.9°C	Relative Humidity	54%
Atmosphere Pressure	101kPa	Test Voltage	AC 120V, 60Hz

RESULTS

Mode	On Time (msec)	Period (msec)	Duty Cycle x (Linear)	Duty Cycle (%)	Duty Cycle Correction Factor (dB)	1/T Minimum VBW (KHz)	Final setting For VBW (KHz)
11b	8.420	8.515	0.989	98.9	0.05	0.19	0.01
11g	1.397	1.499	0.932	93.2	0.31	0.71	1
11n20	1.308	1.411	0.927	92.7	0.33	0.76	1

Note:

Duty Cycle Correction Factor=10log (1/x).

Where: x is Duty Cycle (Linear)

Where: T is On Time

If that calculated VBW is not available on the analyzer then the next higher value should be used.

For mode 11b, the duty cycle is greater than 98%, so it can set VBW to 10Hz.

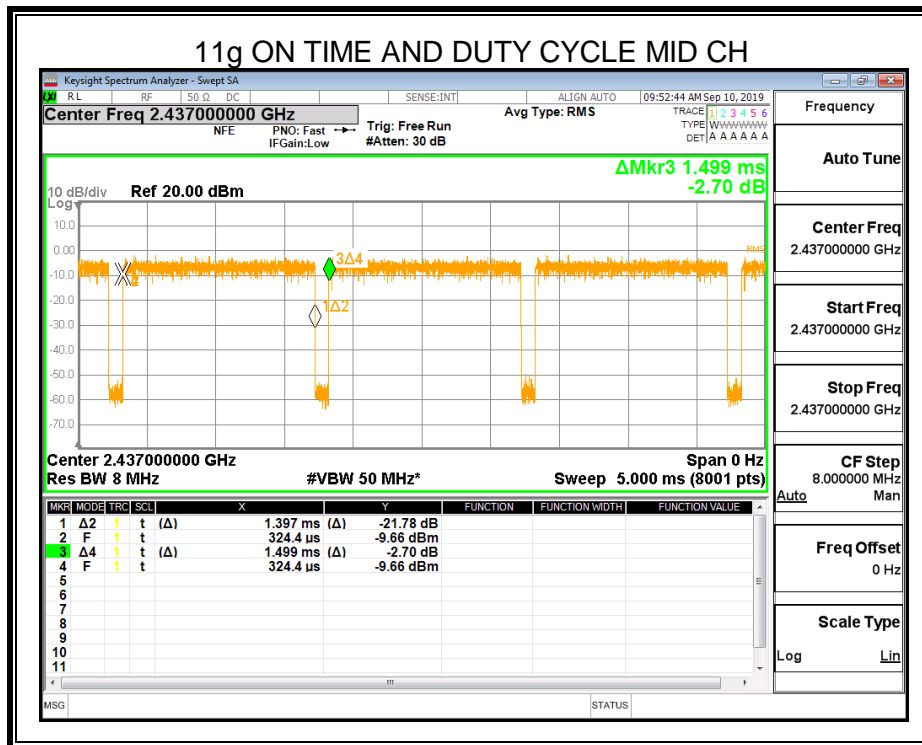
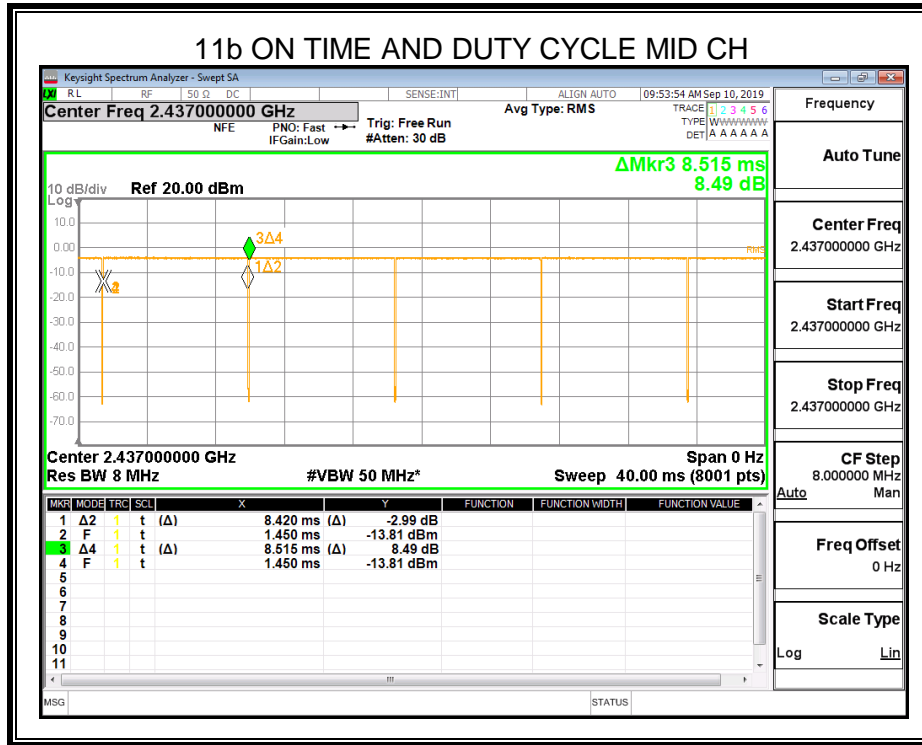

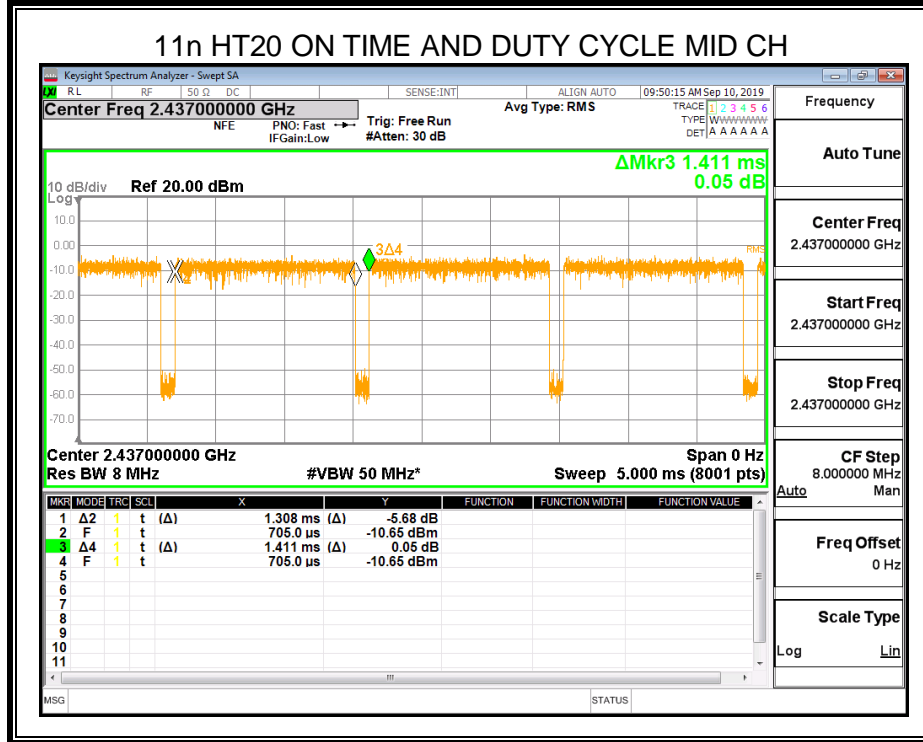

8.2. 6 dB DTS BANDWIDTH AND 99% OCCUPIED BANDWIDTH

LIMITS

CFR 47 FCC Part15 (15.247) Subpart C ISED RSS-247 ISSUE 2			
Section	Test Item	Limit	Frequency Range (MHz)
CFR 47 FCC 15.247(a)(2) ISED RSS-247 5.2 (a)	6 dB Bandwidth	≥ 500KHz	2400-2483.5
ISED RSS-Gen Clause 6.7	99% Occupied Bandwidth	For reporting purposes only.	2400-2483.5

TEST PROCEDURE

Connect the UUT to the spectrum analyser and use the following settings:

Center Frequency	The centre frequency of the channel under test
Detector	Peak
RBW	For 6dB Bandwidth :100kHz For 99% Occupied Bandwidth :1% to 5% of the occupied bandwidth
VBW	For 6dB Bandwidth : ≥3 × RBW For 99% Occupied Bandwidth : approximately 3×RBW
Trace	Max hold
Sweep	Auto couple

Allow the trace to stabilize and measure the maximum width of the emission that is constrained by the frequencies associated with the two outermost amplitude points (upper and lower frequencies) that are attenuated by 6 dB and 99% relative to the maximum level measured in the fundamental emission.

TEST SETUP

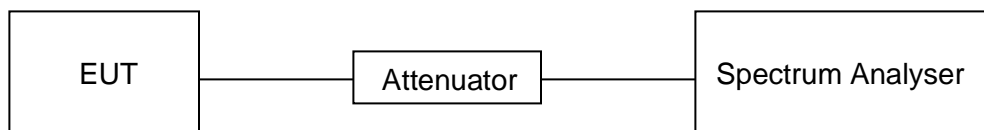



TEST ENVIRONMENT

Temperature	25.9°C	Relative Humidity	54%
Atmosphere Pressure	101kPa	Test Voltage	AC 120V, 60Hz

RESULTS

8.2.1. 802.11b MODE

Channel	6dB bandwidth (MHz)	99% bandwidth (MHz)	Limit (kHz)	Result
Low	8.077	12.019	≥500	Pass
Middle	8.026	11.982	≥500	Pass
High	8.083	12.051	≥500	Pass

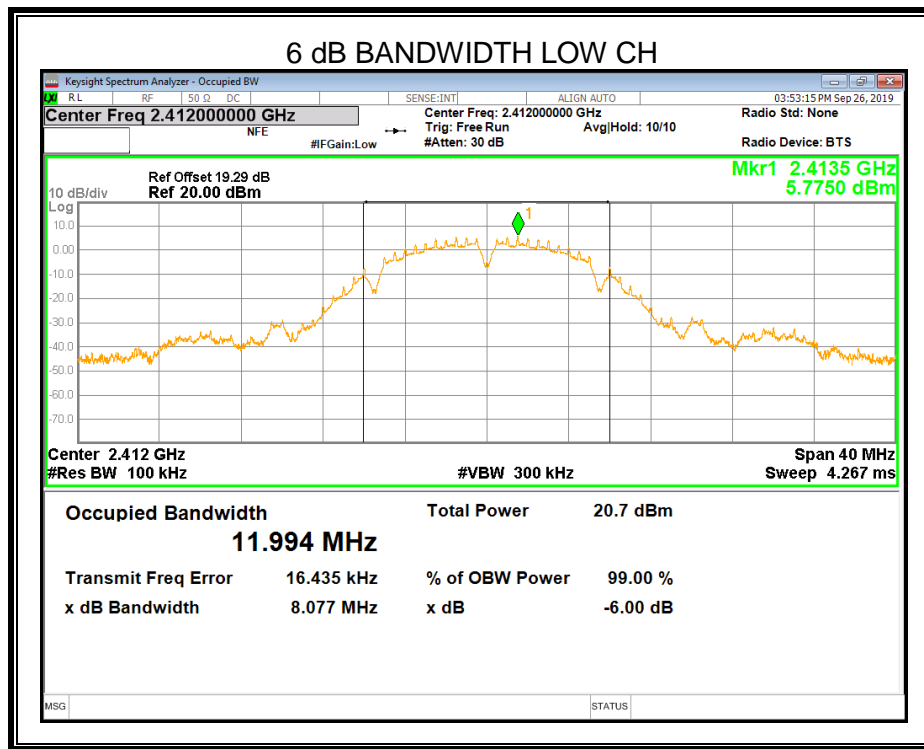

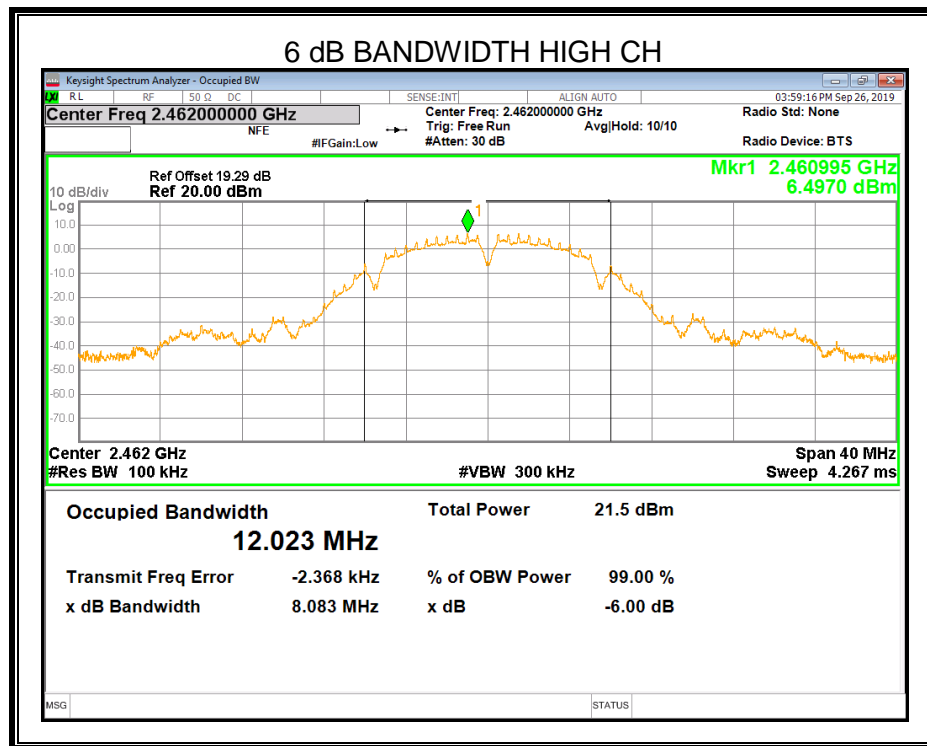
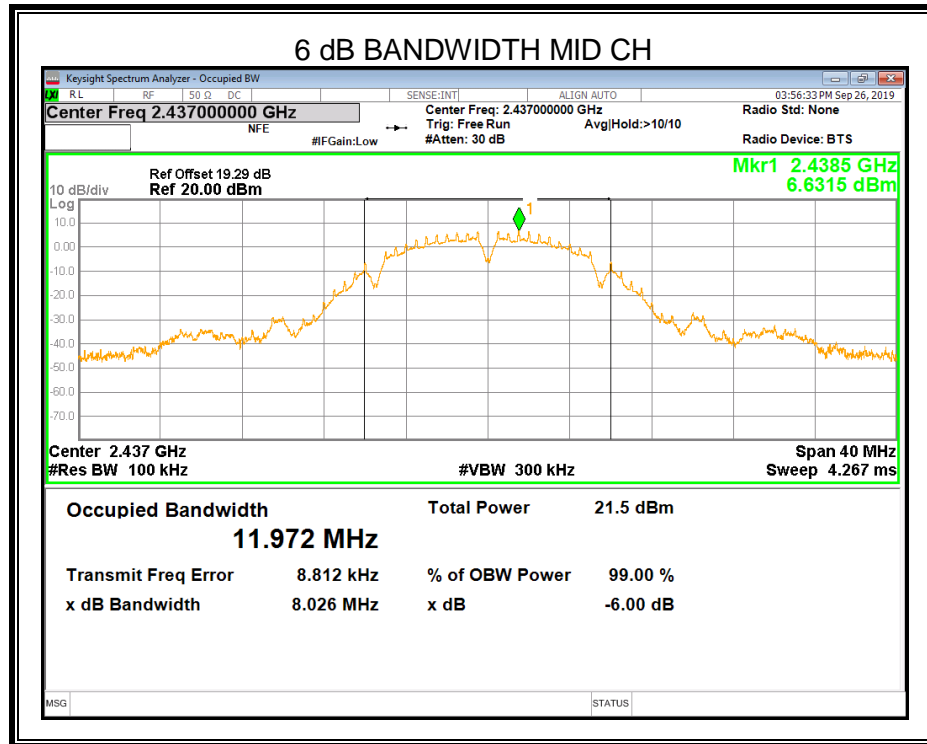

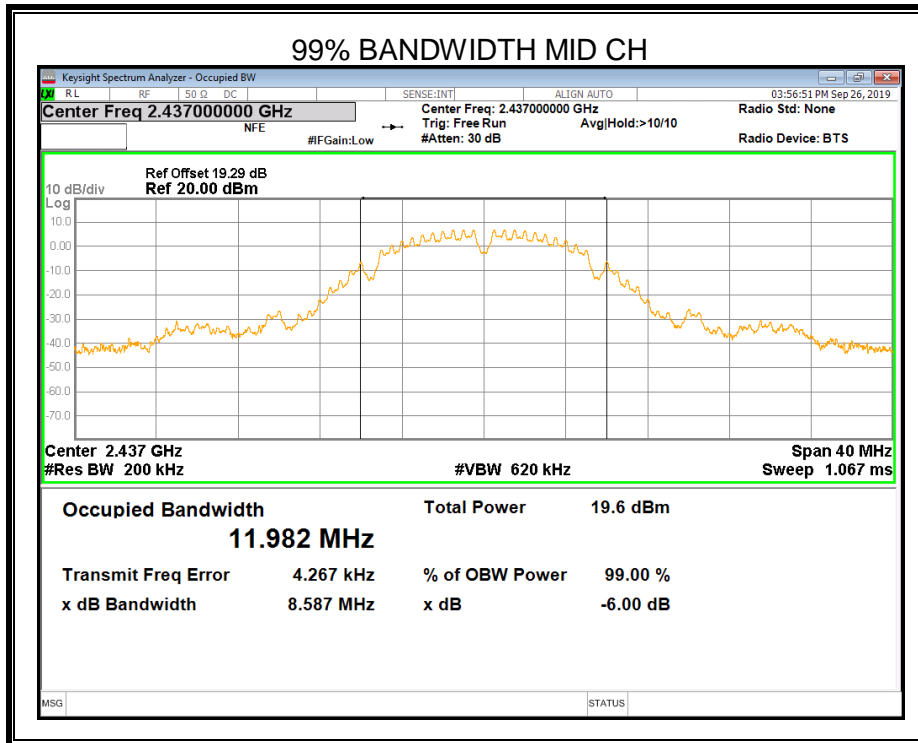
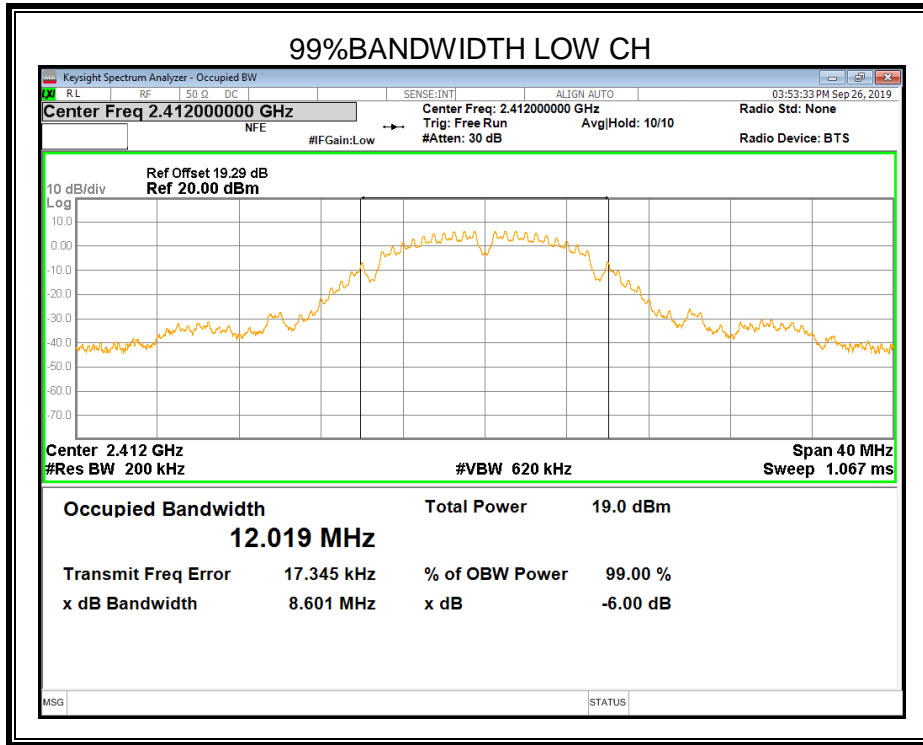

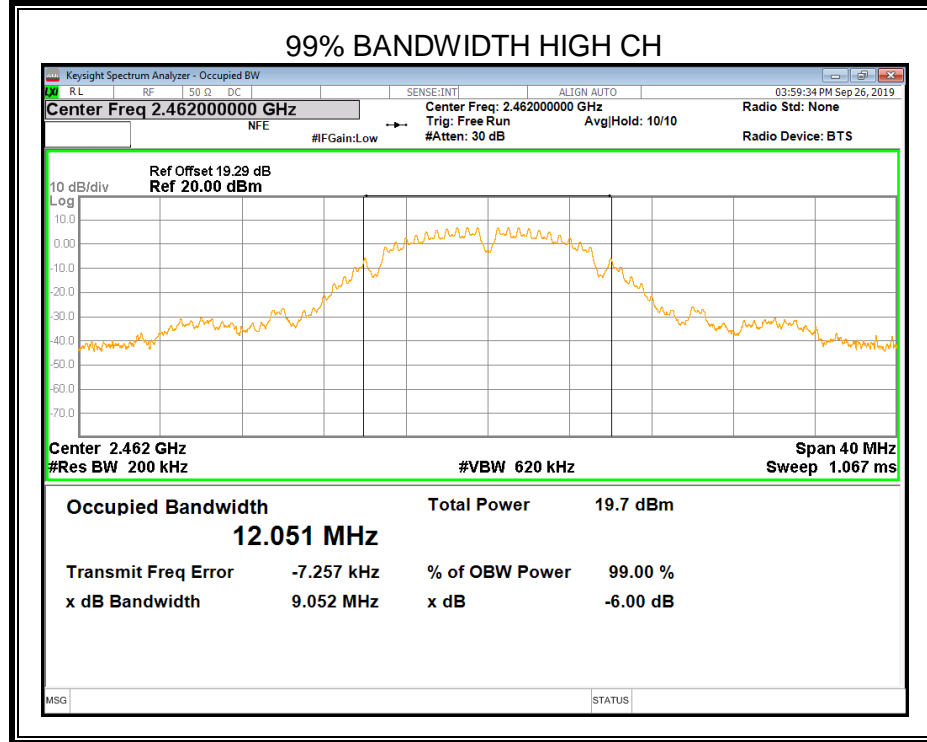



8.2.2. 802.11g MODE

Channel	6dB bandwidth (MHz)	99% bandwidth (MHz)	Limit (kHz)	Result
Low	16.30	16.589	≥500	Pass
Middle	16.30	16.544	≥500	Pass
High	16.02	16.471	≥500	Pass

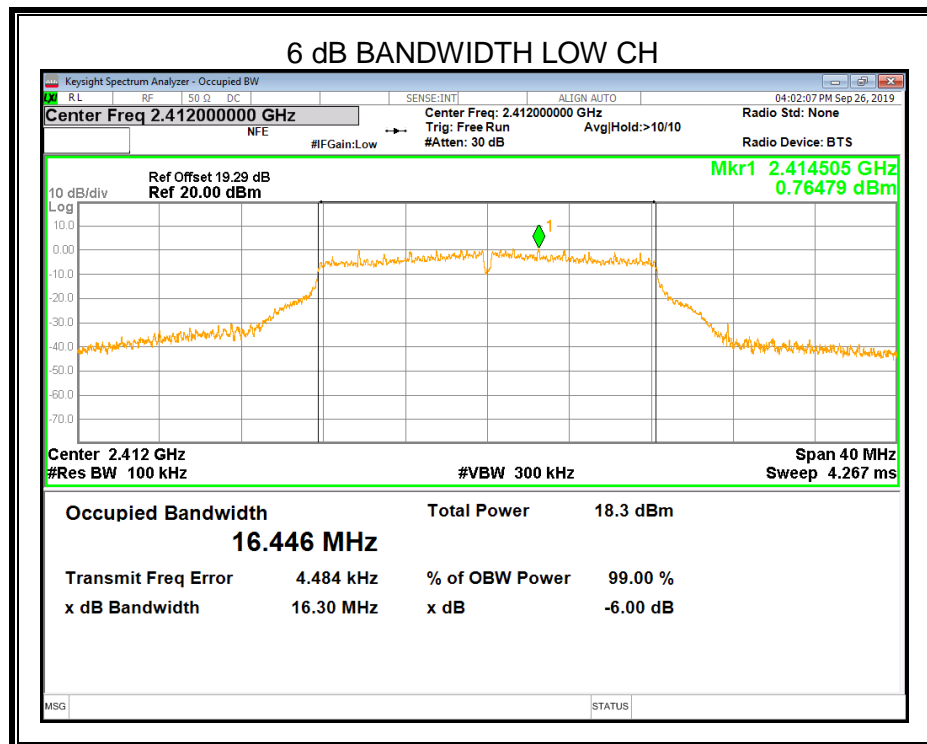

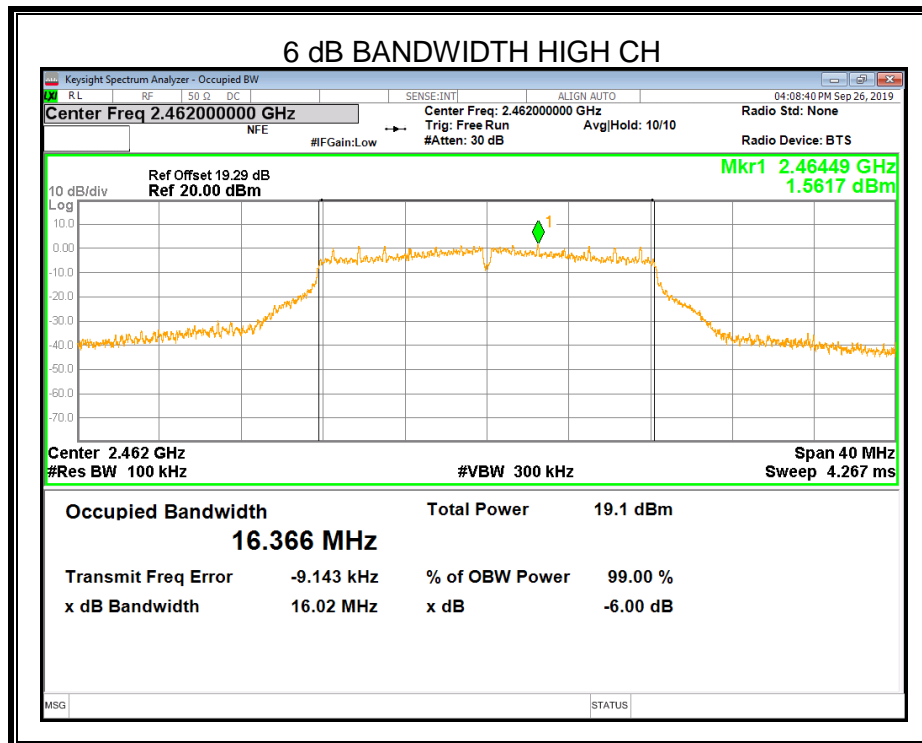
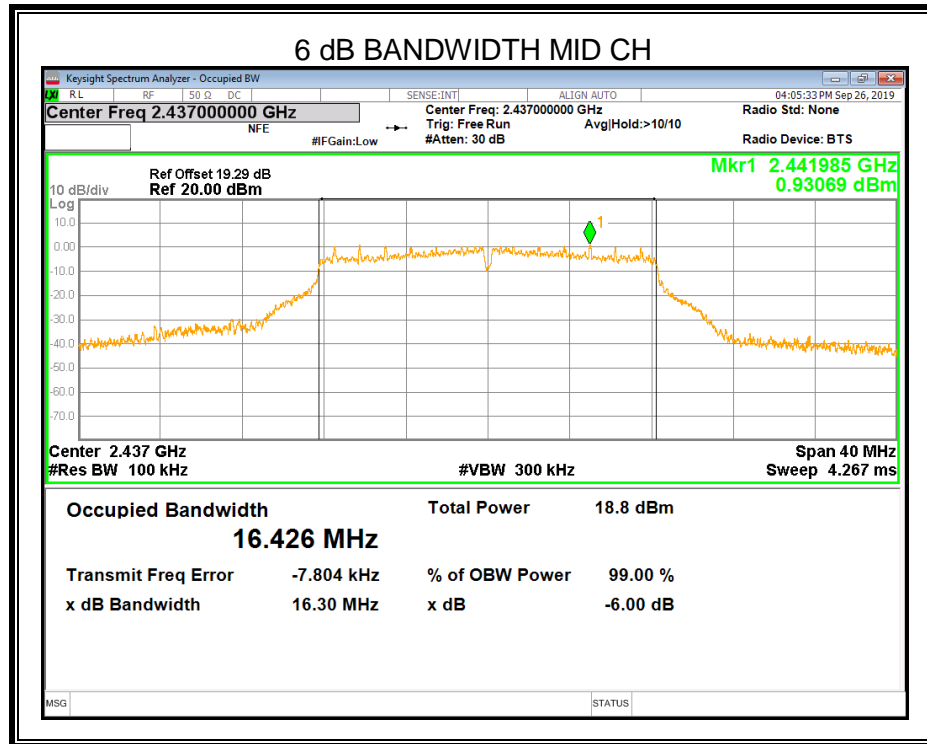

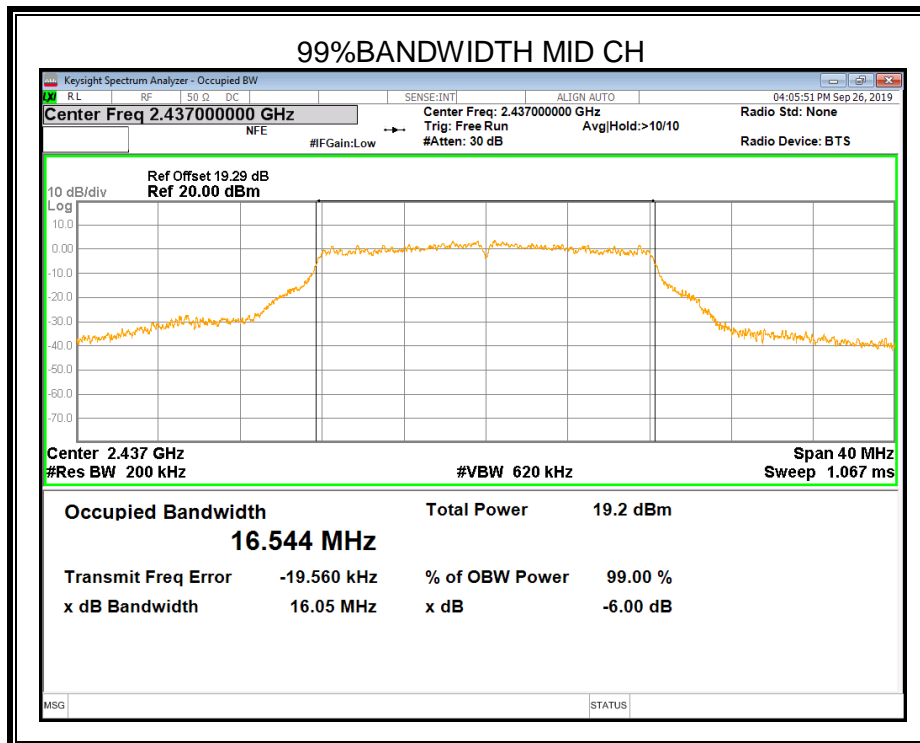
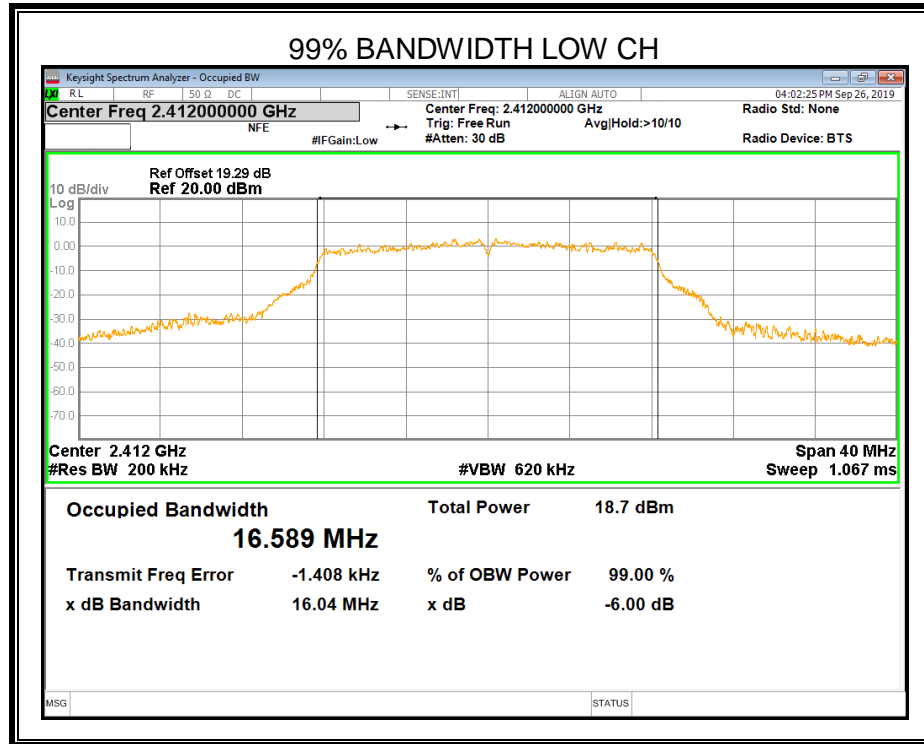

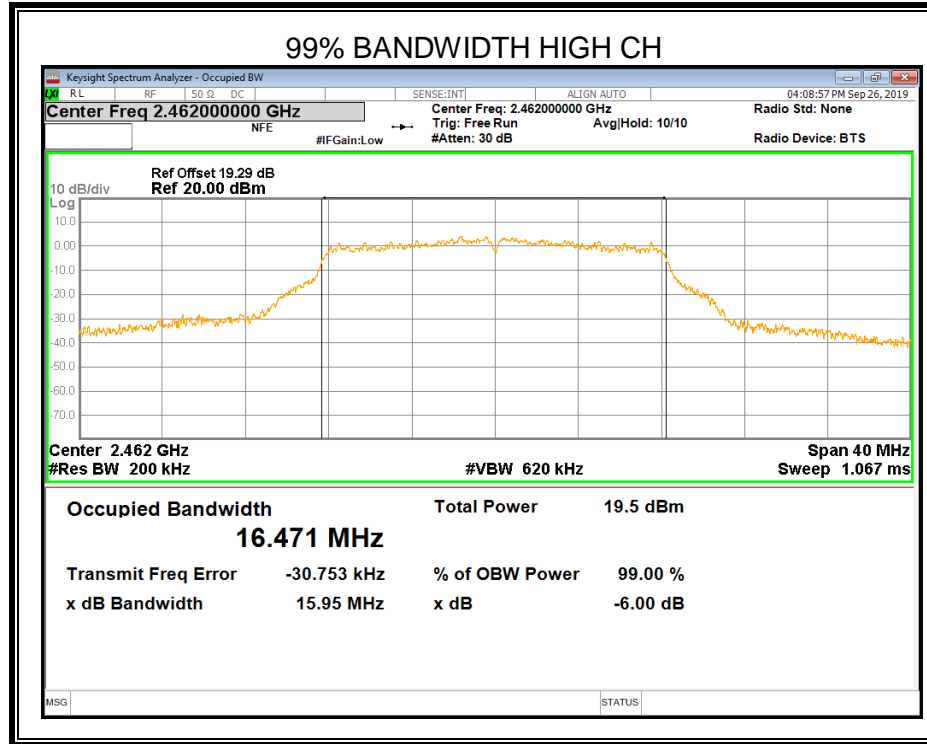



8.2.3. 802.11n HT20 MODE

Channel	6dB bandwidth (MHz)	99% bandwidth (MHz)	Limit (kHz)	Result
Low	16.51	17.740	≥500	Pass
Middle	16.76	17.690	≥500	Pass
High	15.80	17.611	≥500	Pass

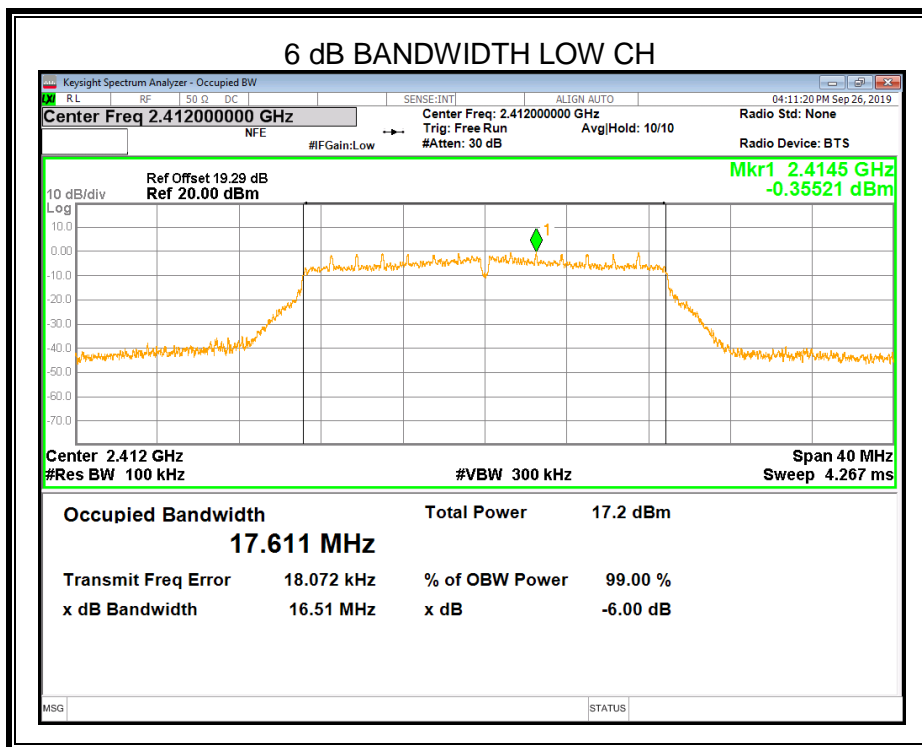

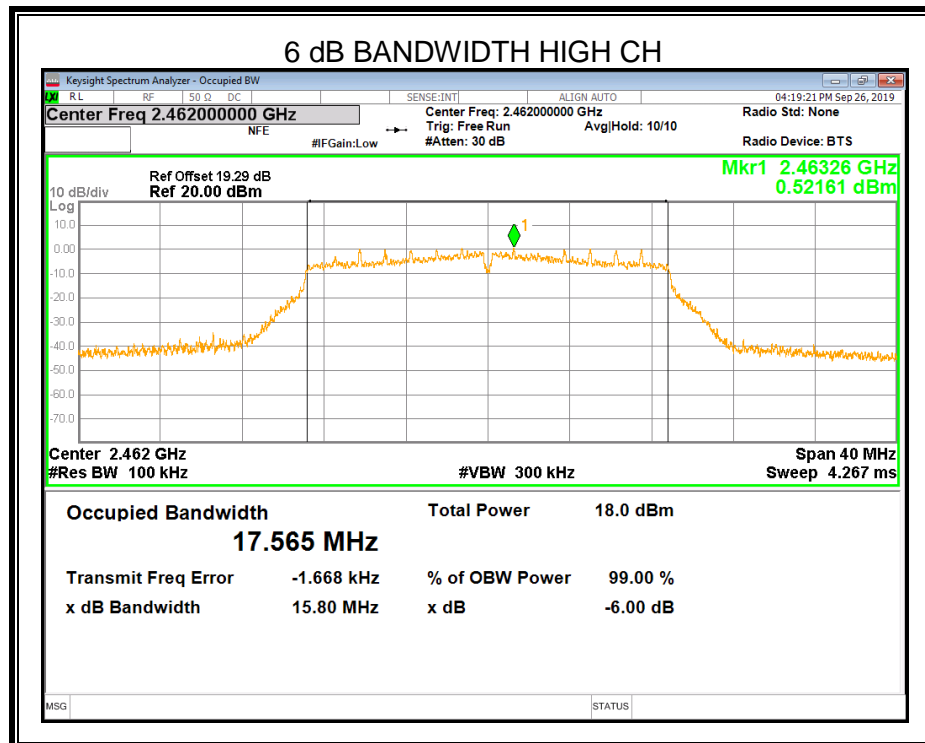
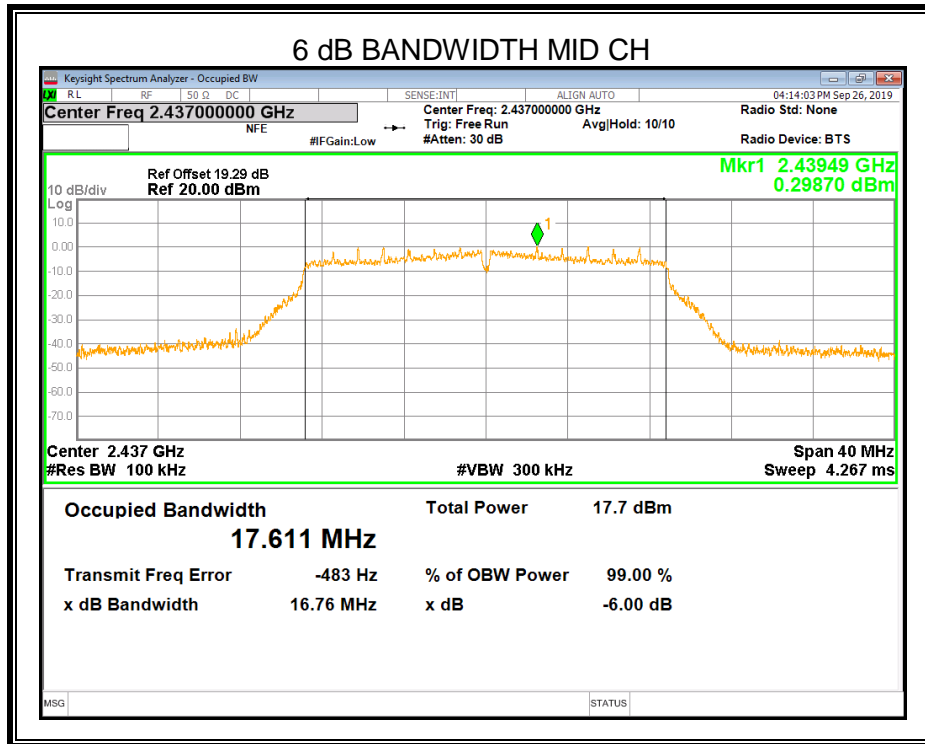

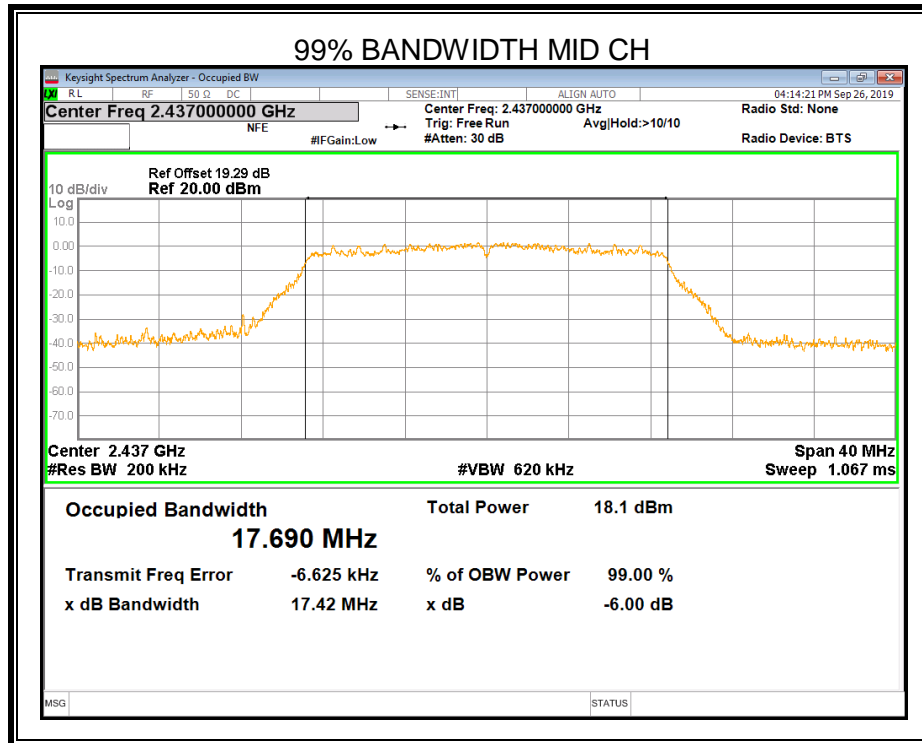
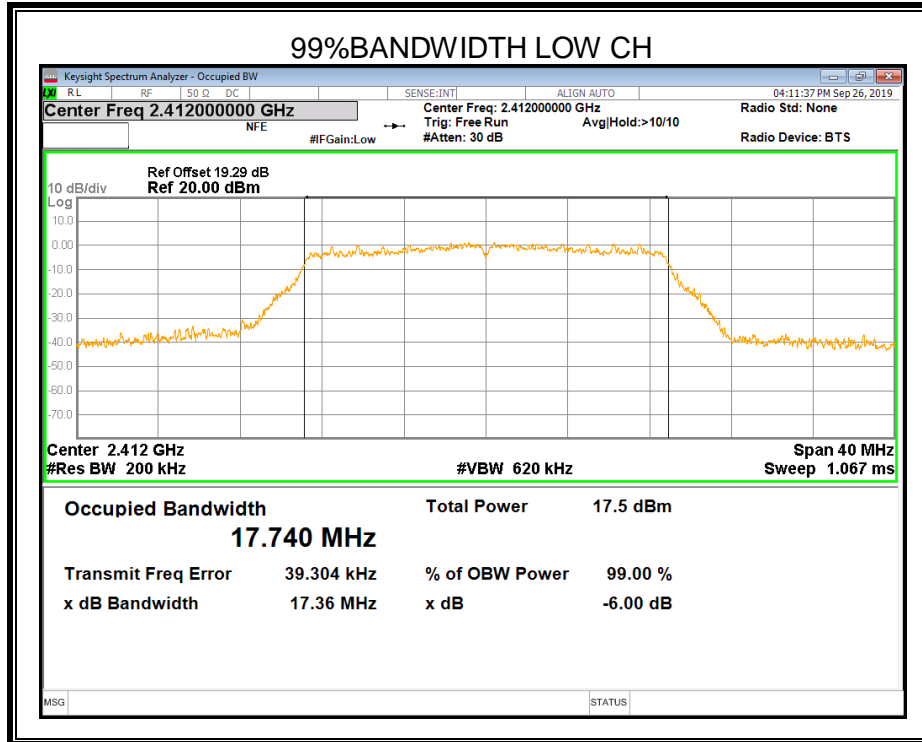

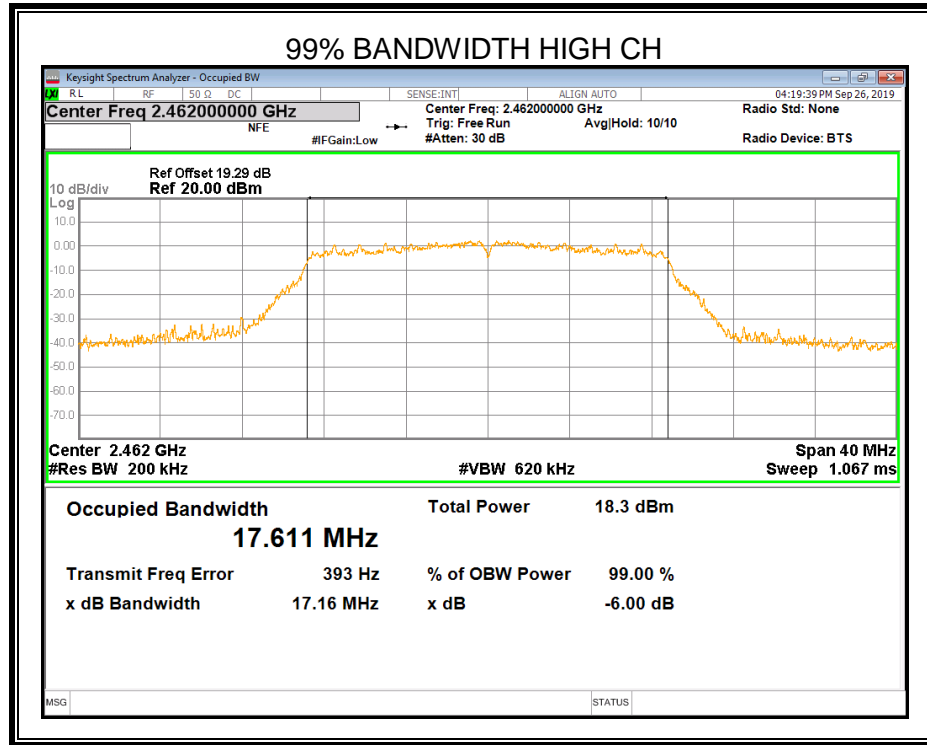



8.3. PEAK CONDUCTED OUTPUT POWER

LIMITS

CFR 47 FCC Part15 (15.247) Subpart C ISED RSS-247 ISSUE 2			
Section	Test Item	Limit	Frequency Range (MHz)
CFR 47 FCC 15.247(b)(3) ISED RSS-247 5.4 (d)	Peak Output Power	1 watt or 30dBm	2400-2483.5

TEST PROCEDURE

Place the EUT on the table and set it in the transmitting mode.
Remove the antenna from the EUT and then connect a low loss RF cable from the antenna port to the Power sensor.
Measure peak power each channel.
Peak Detector use for Peak result.
AVG Detector use for AVG result.

TEST SETUP

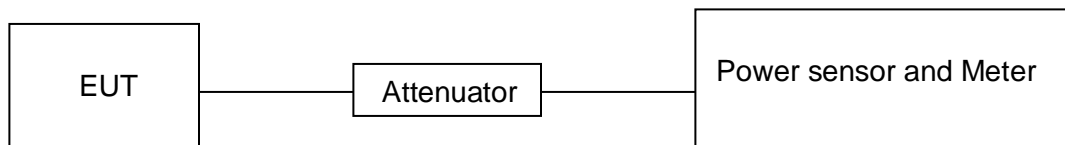

TEST ENVIRONMENT

Temperature	25.9°C	Relative Humidity	54%
Atmosphere Pressure	101kPa	Test Voltage	AC 120V, 60Hz



RESULTS

8.3.1. 802.11b MODE

Test Channel	Maximum Conducted Output Power(PK)	Maximum Conducted Output Power(AV)	LIMIT
	(dBm)	(dBm)	dBm
Low	16.37	14.22	30
Middle	16.93	14.90	30
High	16.97	14.96	30

8.3.2. 802.11g MODE

Test Channel	Maximum Conducted Output Power(PK)	Maximum Conducted Output Power(AV)	LIMIT
	(dBm)	(dBm)	dBm
Low	19.42	12.39	30
Middle	19.83	12.79	30
High	20.10	13.07	30

8.3.3. 802.11n HT20 MODE

Test Channel	Maximum Conducted Output Power(PK)	Maximum Conducted Output Power(AV)	LIMIT
	(dBm)	(dBm)	dBm
Low	18.45	10.94	30
Middle	19.11	11.51	30
High	19.20	11.72	30

8.4. POWER SPECTRAL DENSITY

LIMITS

CFR 47 FCC Part15 (15.247) Subpart C ISED RSS-247 ISSUE 2			
Section	Test Item	Limit	Frequency Range (MHz)
CFR 47 FCC §15.247 (e) ISED RSS-247 5.2 (b)	Power Spectral Density	8 dBm/3 kHz	2400-2483.5

TEST PROCEDURE

Connect the UUT to the spectrum analyser and use the following settings:

Center Frequency	The centre frequency of the channel under test
Detector	Peak
RBW	$3 \text{ kHz} \leq \text{RBW} \leq 100 \text{ kHz}$
VBW	$\geq 3 \times \text{RBW}$
Span	1.5 x DTS bandwidth
Trace	Max hold
Sweep time	Auto couple.

Allow trace to fully stabilize and use the peak marker function to determine the maximum amplitude level within the RBW.
If measured value exceeds limit, reduce RBW (no less than 3 kHz) and repeat.

TEST SETUP

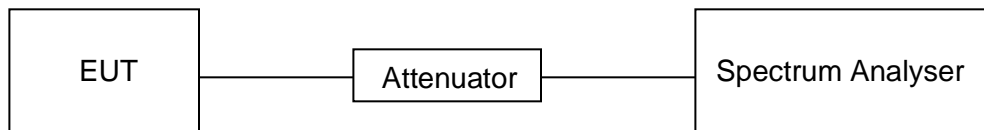

TEST ENVIRONMENT

Temperature	24.9°C	Relative Humidity	54%
Atmosphere Pressure	101kPa	Test Voltage	AC 120V, 60Hz



RESULTS

Please refer to appendix G.



8.5. CONDUCTED BANDEGE AND SPURIOUS EMISSIONS

LIMITS

CFR 47 FCC Part15 (15.247) Subpart C ISED RSS-247 ISSUE 2		
Section	Test Item	Limit
CFR 47 FCC §15.247 (d) ISED RSS-247 5.5	Conducted Bandedge and Spurious Emissions	at least 20 dB below that in the 100 kHz bandwidth within the band that contains the highest level of the desired power

TEST PROCEDURE

Connect the UUT to the spectrum analyser and use the following settings:

Center Frequency	The centre frequency of the channel under test
Detector	Peak
RBW	100kHz
VBW	$\geq 3 \times \text{RBW}$
Span	1.5 x DTS bandwidth
Trace	Max hold
Sweep time	Auto couple.

Use the peak marker function to determine the maximum PSD level.

Span	Set the center frequency and span to encompass frequency range to be measured
Detector	Peak
RBW	100kHz
VBW	$\geq 3 \times \text{RBW}$
measurement points	$\geq \text{span}/\text{RBW}$
Trace	Max hold
Sweep time	Auto couple.

Use the peak marker function to determine the maximum amplitude level.



TEST SETUP

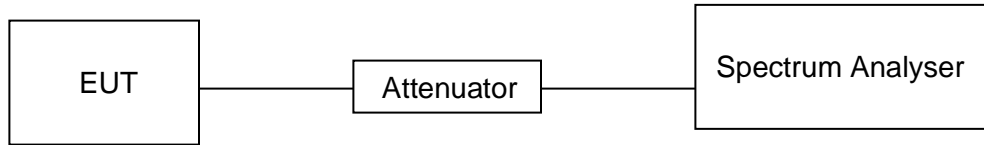

TEST ENVIRONMENT

Temperature	25.9°C	Relative Humidity	54%
Atmosphere Pressure	101kPa	Test Voltage	AC 120V, 60Hz

RESULTS

Please refer to appendix E and F.



9. RADIATED TEST RESULTS

LIMITS

Please refer to CFR 47 FCC §15.205 and §15.209

Please refer to ISED RSS-GEN Clause 8.9 (Transmitter)

Radiation Disturbance Test Limit for FCC (Class B)(9KHz-1GHz)

Frequency (MHz)	Field Strength (microvolts/meter)	Measurement Distance (meters)
0.009~0.490	2400/F(KHz)	300
0.490~1.705	24000/F(KHz)	30
1.705~30.0	30	30
30~88	100	3
88~216	150	3
216~960	200	3
960~1000	500	3

Note: 1) At frequencies at or above 30 MHz, measurements may be performed at a distance other than what is specified provided: measurements are not made in the near field except where it can be shown that near field measurements are appropriate due to the characteristics of the device; and it can be demonstrated that the signal levels needed to be measured at the distance employed can be detected by the measurement equipment. Measurements shall not be performed at a distance greater than 30 meters unless it can be further demonstrated that measurements at a distance of 30 meters or less are impractical. When performing measurements at a distance other than that specified, the results shall be extrapolated to the specified distance using an extrapolation factor of 20 dB/decade (inverse linear-distance for field strength measurements; inverse-linear-distance-squared for power density measurements).

(2) At frequencies below 30 MHz, measurements may be performed at a distance closer than that specified in the regulations; however, an attempt should be made to avoid making measurements in the near field. Pending the development of an appropriate measurement procedure for measurements performed below 30 MHz, when performing measurements at a closer distance than specified, the results shall be extrapolated to the specified distance by either making measurements at a minimum of two distances on at least one radial to determine the proper extrapolation factor or by using the square of an inverse linear distance extrapolation factor (40 dB/decade). This paragraph (f) shall not apply to Access BPL devices operating below 30 MHz.



Radiation Disturbance Test Limit for FCC (Above 1G)

Frequency (MHz)	dB(uV/m) (at 3 meters)	
	Peak	Average
Above 1000	74	54

IC Restricted bands please refer to ISED RSS-GEN Clause 8.10

FCC Restricted bands of operation:

MHz	MHz	MHz	GHz
0.090-0.110	16.42-16.423	399.9-410	4.5-5.15
¹ 0.495-0.505	16.69475-16.69525	608-614	5.35-5.46
2.1735-2.1905	16.80425-16.80475	960-1240	7.25-7.75
4.125-4.128	25.5-25.67	1300-1427	8.025-8.5
4.17725-4.17775	37.5-38.25	1435-1626.5	9.0-9.2
4.20725-4.20775	73-74.6	1645.5-1646.5	9.3-9.5
6.215-6.218	74.8-75.2	1660-1710	10.6-12.7
6.26775-6.26825	108-121.94	1718.8-1722.2	13.25-13.4
6.31175-6.31225	123-138	2200-2300	14.47-14.5
8.291-8.294	149.9-150.05	2310-2390	15.35-16.2
8.362-8.366	156.52475-156.52525	2483.5-2500	17.7-21.4
8.37625-8.38675	156.7-156.9	2690-2900	22.01-23.12
8.41425-8.41475	162.0125-167.17	3260-3267	23.6-24.0
12.29-12.293	167.72-173.2	3332-3339	31.2-31.8
12.51975-12.52025	240-285	3345.8-3358	36.43-36.5
12.57675-12.57725	322-335.4	3600-4400	(²)
13.36-13.41			

Note: ¹Until February 1, 1999, this restricted band shall be 0.490-0.510 MHz.

²Above 38.6c

TEST SETUP AND PROCEDURE

Below 30MHz

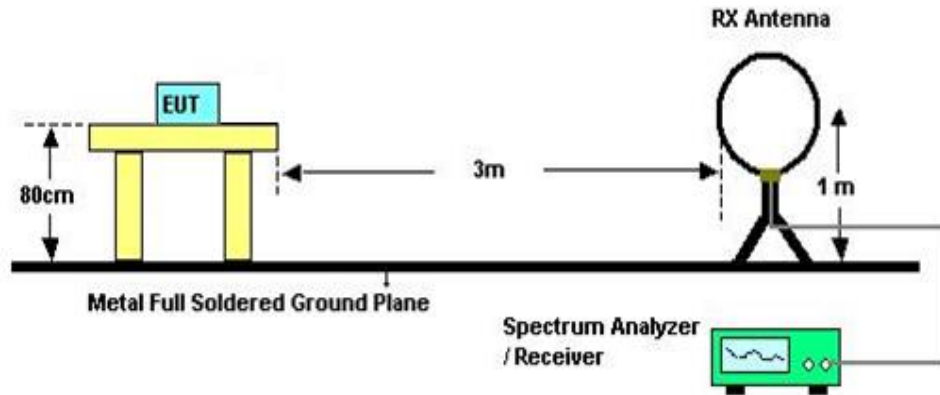

The setting of the spectrum analyser

RBW	200Hz (From 9kHz to 0.15MHz)/ 9kHz (From 0.15MHz to 30MHz)
VBW	200Hz (From 9kHz to 0.15MHz)/ 9kHz (From 0.15MHz to 30MHz)
Sweep	Auto
Detector	Peak/QP/ Average
Trace	Max hold

1. The testing follows the guidelines in ANSI C63.10-2013
2. The EUT was arranged to its worst case and then turntable (from 0 degree to 360 degrees) to find the maximum reading. A pre-amp and a high pass filter are used for the test in order to get better signal level. Both Horizontal, Face-on and Face-off polarizations of the antenna are set to make the measurement.
3. The EUT was placed on a turntable with 0.8 meter above ground.
4. The EUT was set 3 meters from the interference receiving antenna, which was mounted on the top of 1 meter height antenna tower.
5. For measurement below 1GHz, the initial step in collecting conducted emission data is a spectrum analyzer peak detector mode pre-scanning the measurement frequency range. Significant peaks are then marked and then Quasi Peak detector mode re-measured. If the emission level of the EUT measured by the peak detector is 3 dB lower than the applicable limit, the peak emission level will be reported. Otherwise, the emission measurement will be repeated using the quasi-peak detector and reported.
6. For the actual test configuration, please refer to the related item in this test report (Photographs of the Test Configuration)
7. Although these tests were performed other than open field site, adequate comparison measurements were confirmed against 30m open field site. Therefore sufficient tests were made to demonstrate that the alternative site produces results that correlate with the ones of tests made in an open field site based on KDB 414788.

Below 1G

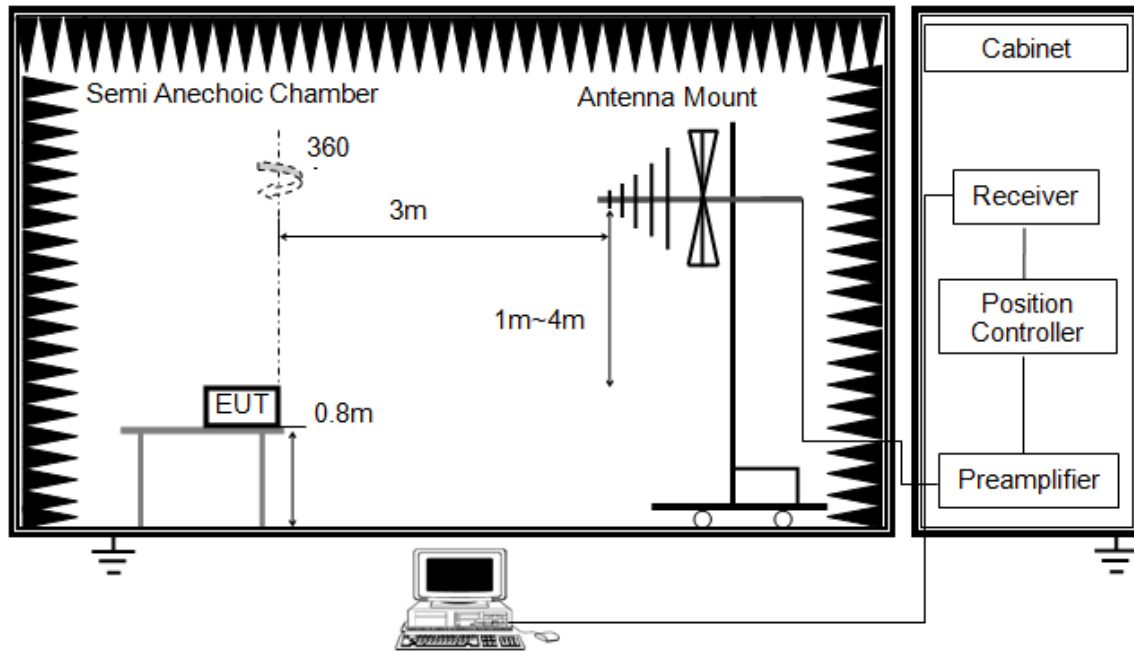

The setting of the spectrum analyser

RBW	120kHz
VBW	300kHz
Sweep	Auto
Detector	Peak/QP
Trace	Max hold

1. The testing follows the guidelines in ANSI C63.10-2013.
2. The EUT was arranged to its worst case and then tune the antenna tower (from 1 m to 4 m) and turntable (from 0 degree to 360 degrees) to find the maximum reading. A pre-amp and a high pass filter are used for the test in order to get better signal level. Both horizontal and vertical polarizations of the antenna are set to make the measurement.
3. The EUT was placed on a turntable with 0.8 meter above ground.
4. The EUT was set 3 meters from the interference receiving antenna, which was mounted on the top of a variable height antenna tower.
5. For measurement below 1GHz, the initial step in collecting conducted emission data is a spectrum analyzer peak detector mode pre-scanning the measurement frequency range. Significant peaks are then marked and then Quasi Peak detector mode re-measured. If the emission level of the EUT measured by the peak detector is 3 dB lower than the applicable limit, the peak emission level will be reported. Otherwise, the emission measurement will be repeated using the quasi-peak detector and reported.

ABOVE 1G

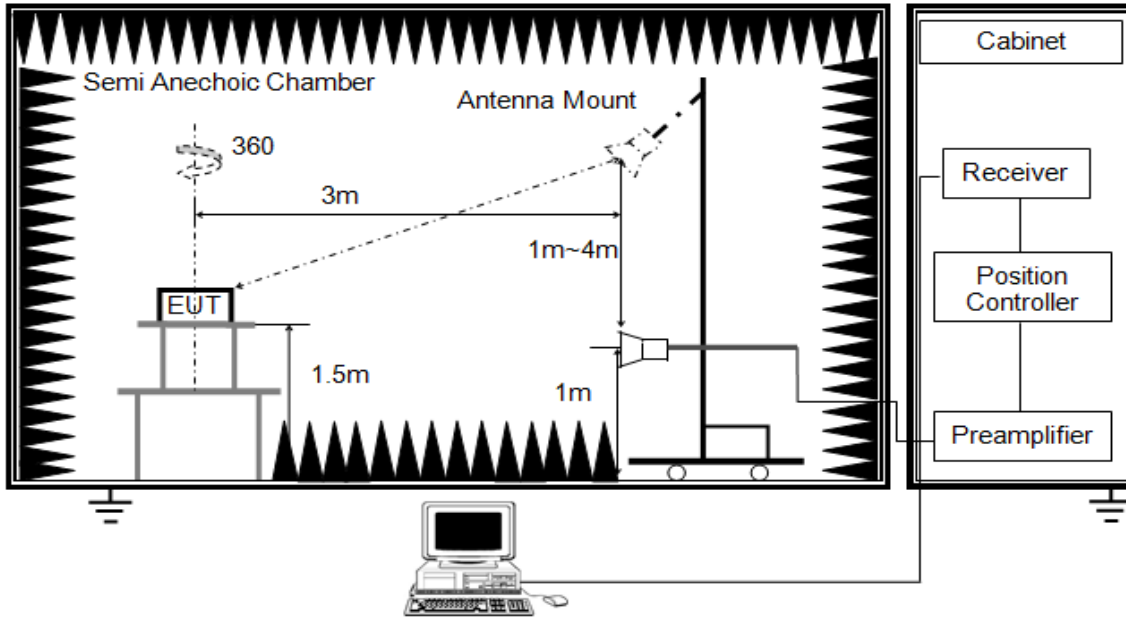

The setting of the spectrum analyser

RBW	1MHz
VBW	PEAK: 3MHz AVG: see note 6
Sweep	Auto
Detector	Peak
Trace	Max hold

1. The testing follows the guidelines in ANSI C63.10-2013.
2. The EUT was arranged to its worst case and then tune the antenna tower (from 1 m to 4 m) and turntable (from 0 degree to 360 degrees) to find the maximum reading. A pre-amp and a high pass filter are used for the test in order to get better signal level. Both horizontal and vertical polarizations of the antenna are set to make the measurement.
3. The EUT was placed on a turntable with 1.5m above ground.
4. The EUT was set 3 meters from the interference receiving antenna, which was mounted on the top of a variable height antenna tower.
5. For measurement above 1GHz, the emission measurement will be measured by the peak detector. This peak level, once corrected, must comply with the limit specified in Section 15.209.
6. For measurements above 1 GHz the resolution bandwidth is set to 1 MHz, then the video bandwidth is set to 3 MHz for peak measurements and 1 MHz resolution bandwidth with 1/T video bandwidth with peak detector for average measurements. For the Duty Cycle please refer to clause 8.1.ON TIME AND DUTY CYCLE.

X axis, Y axis, Z axis positions:

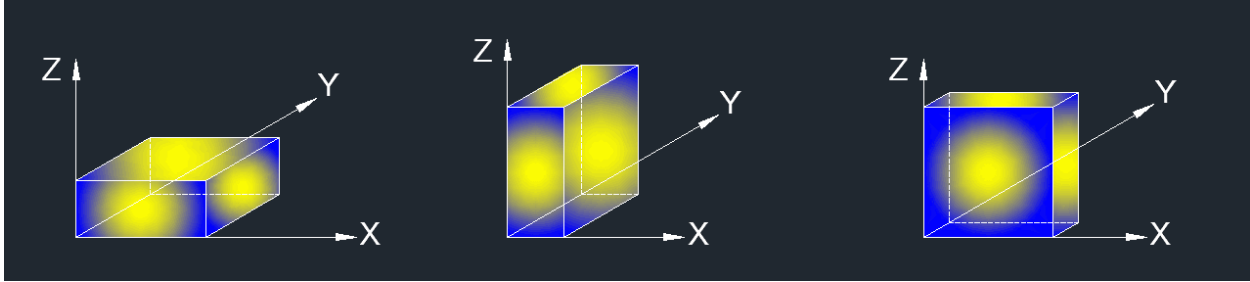

Note 1: For all radiated test, EUT in each of three orthogonal axis emissions had been tested, but only the worst case (X axis) data recorded in the report.

Note 2: The EUT does not support simultaneous transmission.

Note 3: The EUT was fully exercised with external accessories during the test. In the case of multiple accessory external ports, an external accessory shall be connected to one of each type of port.

TEST ENVIRONMENT

Temperature	24.2°C	Relative Humidity	47%
Atmosphere Pressure	101kPa	Test Voltage	AC 120V, 60Hz



9.1. RESTRICTED BANDEDGE

9.1.1. 802.11b MODE

RESTRICTED BANDEDGE (LOW CHANNEL, HORIZONTAL)

PEAK

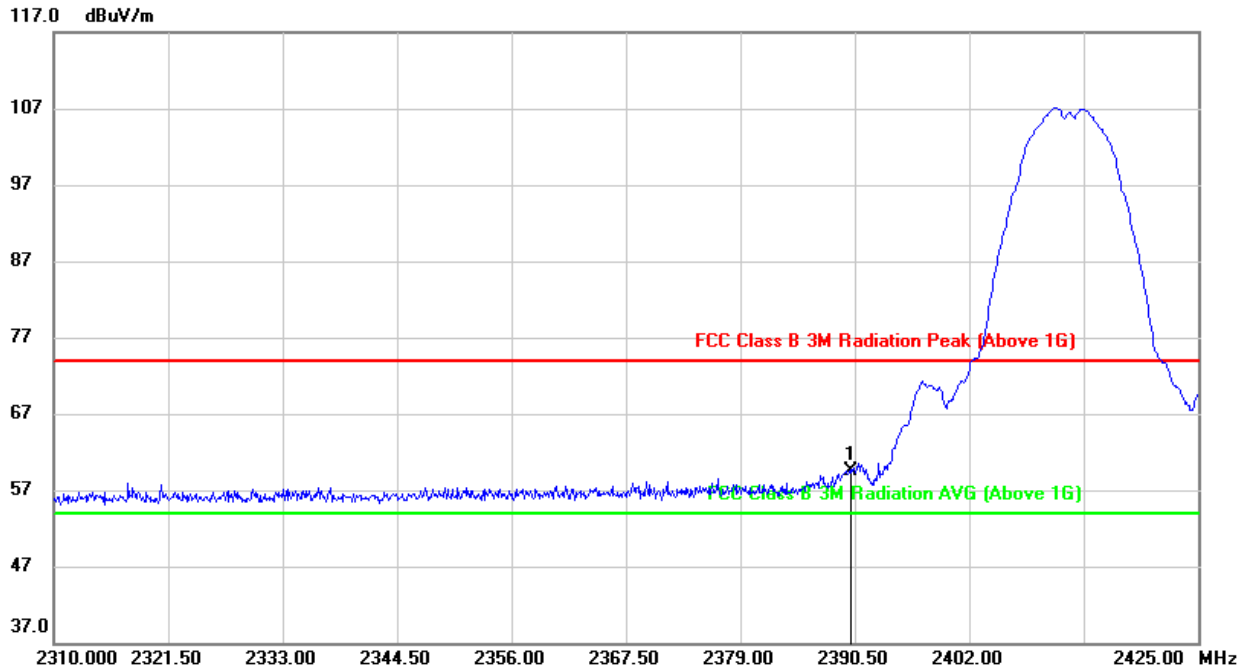

No.	Frequency (MHz)	Reading (dBuV)	Correct (dB/m)	Result (dBuV/m)	Limit (dBuV/m)	Margin (dB)	Remark
1	2390.000	26.66	32.94	59.60	74.00	-14.40	peak

- Note: 1. Measurement = Reading Level + Correct Factor.
 2. If Peak Result complies with AV limit, AV Result is deemed to comply with AV limit.
 3. Peak: Peak detector.
 4. Only the worst case emission was recorded, if it complies with the limit, the other emissions deemed to comply with the limit.



AVG

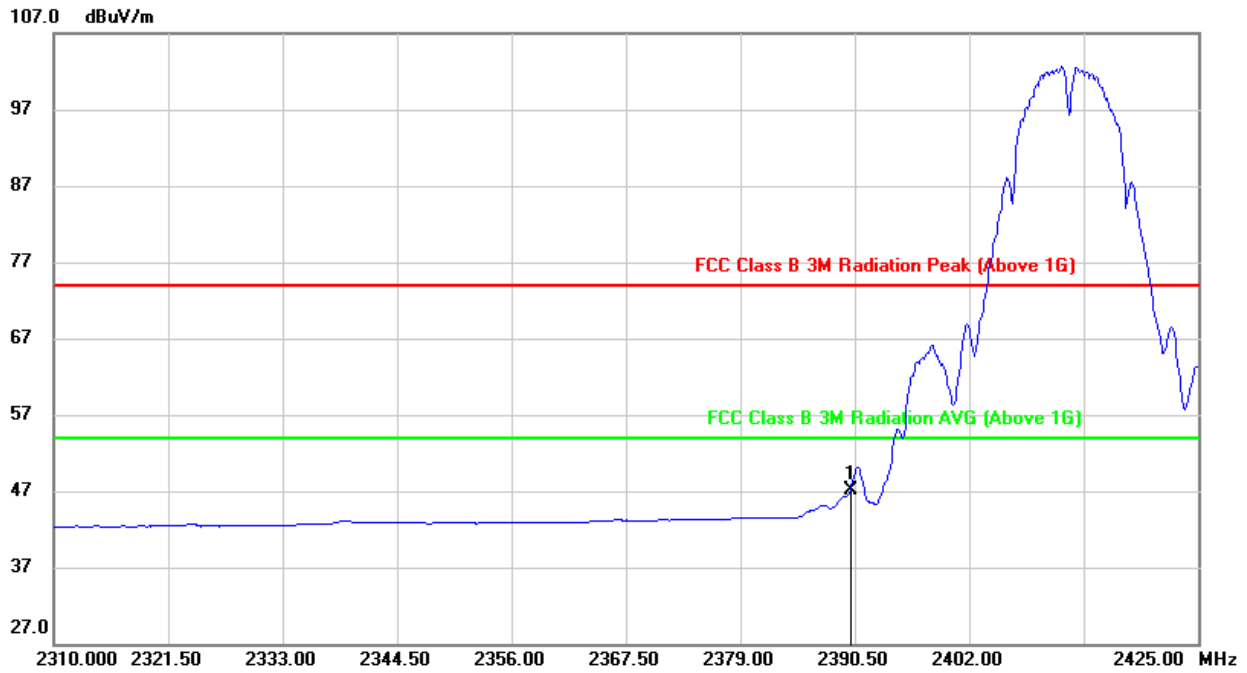

No.	Frequency (MHz)	Reading (dBuV)	Correct (dB/m)	Result (dBuV/m)	Limit (dBuV/m)	Margin (dB)	Remark
1	2390.000	14.22	32.94	47.16	54.00	-6.84	AVG

- Note:
1. Measurement = Reading Level + Correct Factor.
 2. If Peak Result complies with AV limit, AV Result is deemed to comply with AV limit.
 3. AVG: $VBW=1/T_{on}$ where: t_{on} is transmit duration.
 4. For transmit duration, please refer to clause 8.1.
 5. Only the worst case emission was recorded, if it complies with the limit, the other emissions deemed to comply with the limit.



RESTRICTED BANDEDGE (LOW CHANNEL, VERTICAL)

PEAK

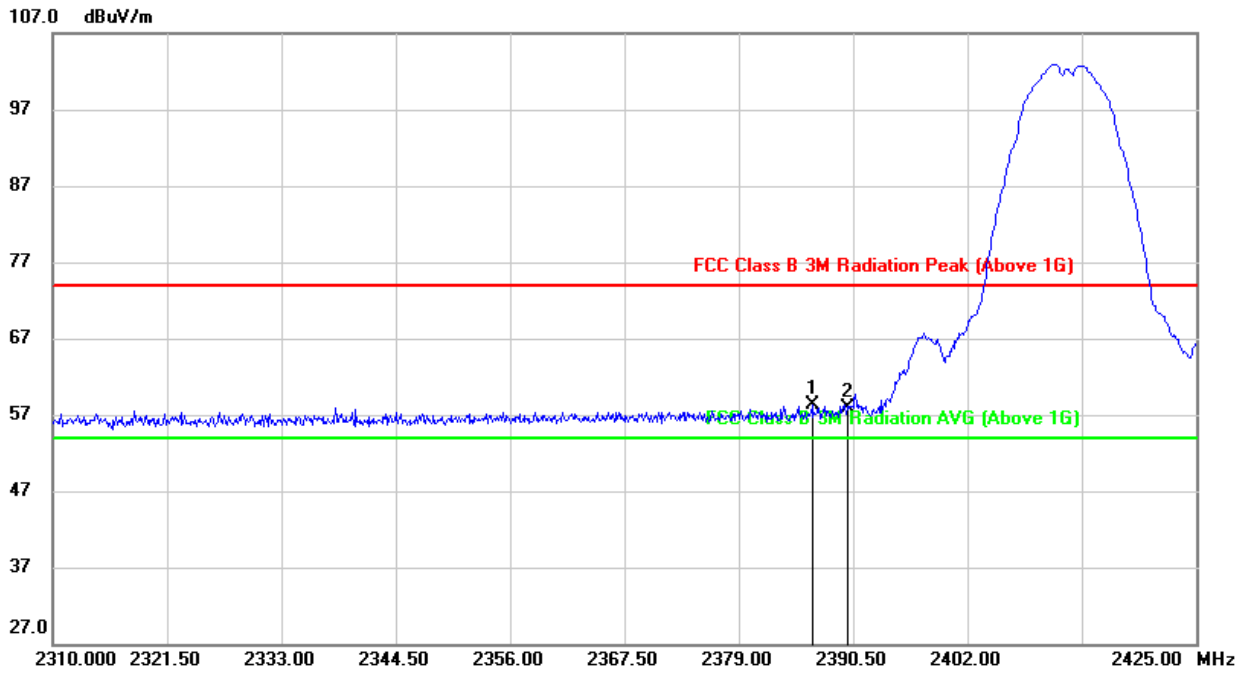

No.	Frequency (MHz)	Reading (dBuV)	Correct (dB/m)	Result (dBuV/m)	Limit (dBuV/m)	Margin (dB)	Remark
1	2386.360	25.43	32.94	58.37	74.00	-15.63	peak
2	2390.000	24.91	32.94	57.85	74.00	-16.15	peak

- Note: 1. Measurement = Reading Level + Correct Factor.
 2. If Peak Result complies with AV limit, AV Result is deemed to comply with AV limit.
 3. Peak: Peak detector.
 4. Only the worst case emission was recorded, if it complies with the limit, the other emissions deemed to comply with the limit.



AVG

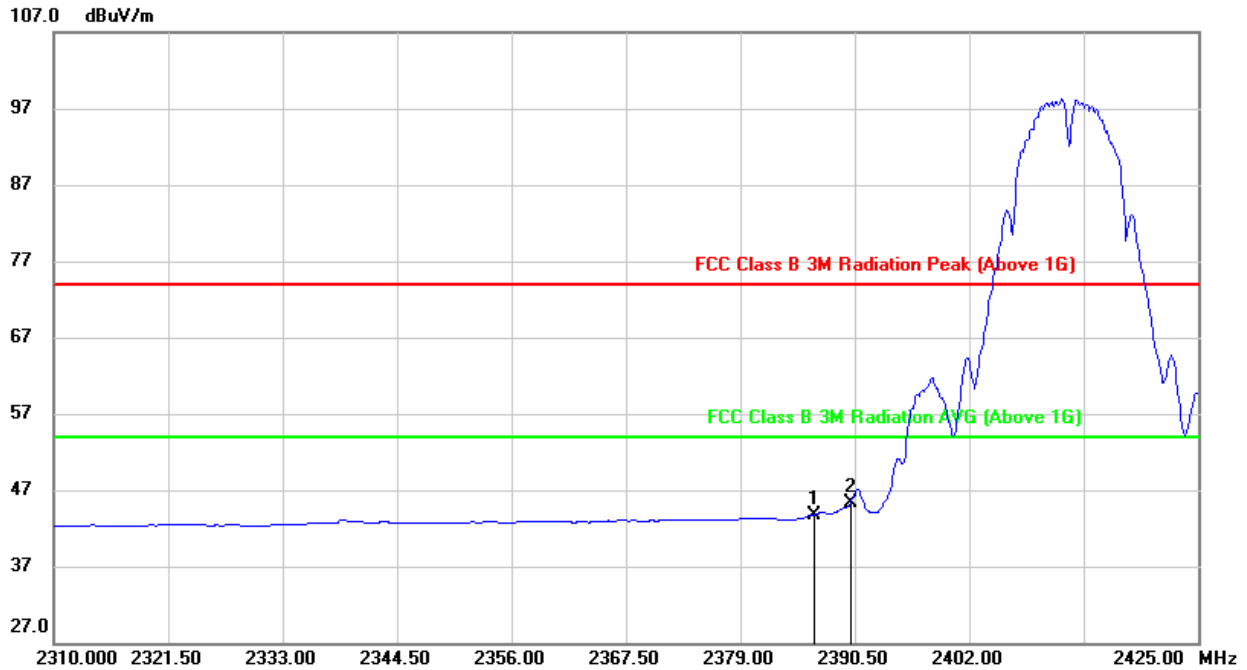

No.	Frequency (MHz)	Reading (dBuV)	Correct (dB/m)	Result (dBuV/m)	Limit (dBuV/m)	Margin (dB)	Remark
1	2386.360	10.85	32.94	43.79	54.00	-10.21	AVG
2	2390.000	12.29	32.94	45.23	54.00	-8.77	AVG

- Note:
1. Measurement = Reading Level + Correct Factor.
 2. If Peak Result complies with AV limit, AV Result is deemed to comply with AV limit.
 3. AVG: $VBW=1/T_{on}$ where: t_{on} is transmit duration.
 4. For transmit duration, please refer to clause 8.1.
 5. Only the worst case emission was recorded, if it complies with the limit, the other emissions deemed to comply with the limit.



RESTRICTED BANDEDGE (HIGH CHANNEL, HORIZONTAL)

PEAK

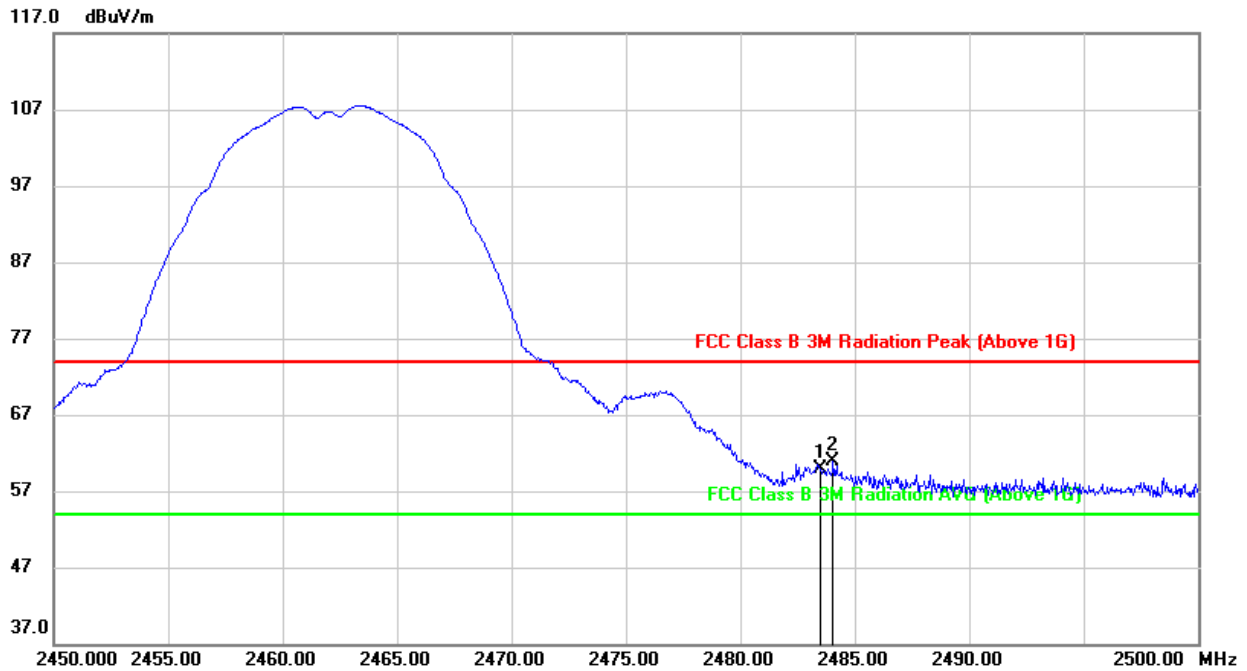

No.	Frequency (MHz)	Reading (dBuV)	Correct (dB/m)	Result (dBuV/m)	Limit (dBuV/m)	Margin (dB)	Remark
1	2483.500	26.24	33.58	59.82	74.00	-14.18	peak
2	2484.050	27.26	33.58	60.84	74.00	-13.16	peak

- Note: 1. Measurement = Reading Level + Correct Factor.
 2. If Peak Result complies with AV limit, AV Result is deemed to comply with AV limit.
 3. Peak: Peak detector.
 4. Only the worst case emission was recorded, if it complies with the limit, the other emissions deemed to comply with the limit.



AVG

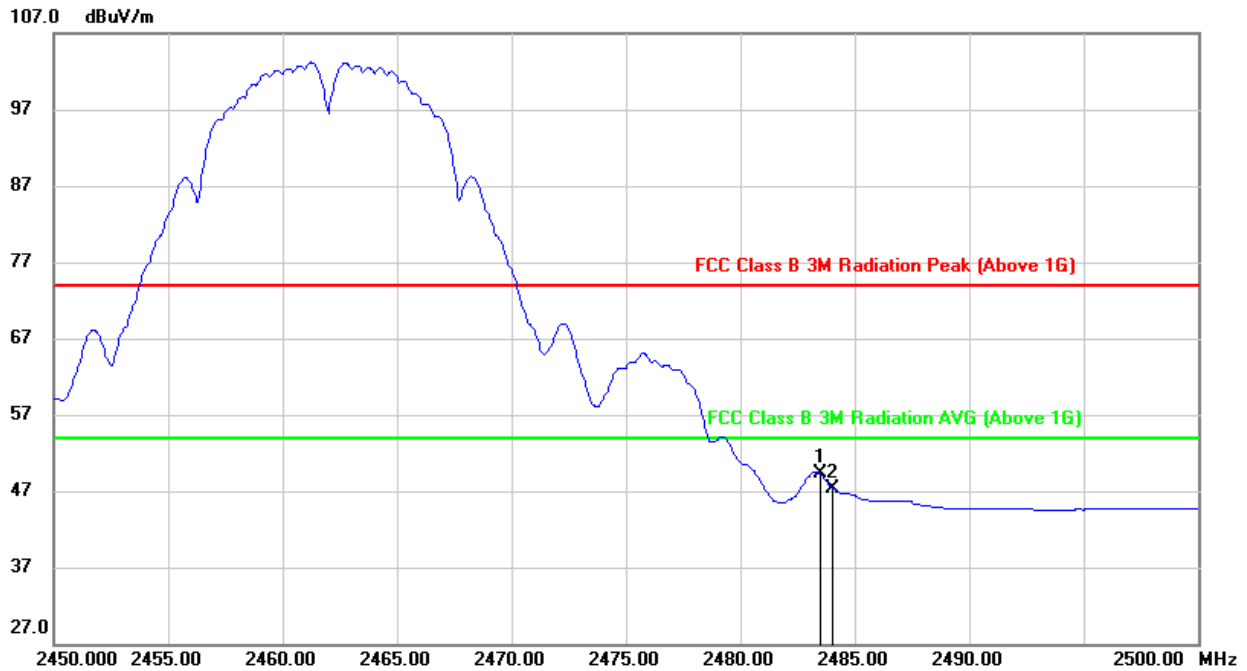

No.	Frequency (MHz)	Reading (dBuV)	Correct (dB/m)	Result (dBuV/m)	Limit (dBuV/m)	Margin (dB)	Remark
1	2483.500	15.63	33.58	49.21	54.00	-4.79	AVG
2	2484.050	13.70	33.58	47.28	54.00	-6.72	AVG

- Note: 1. Measurement = Reading Level + Correct Factor.
 2. If Peak Result complies with AV limit, AV Result is deemed to comply with AV limit.
 3. AVG: $VBW=1/T_{on}$ where: t_{on} is transmit duration.
 4. For transmit duration, please refer to clause 8.1.
 5. Only the worst case emission was recorded, if it complies with the limit, the other emissions deemed to comply with the limit.



RESTRICTED BANDEDGE (HIGH CHANNEL, VERTICAL)

PEAK

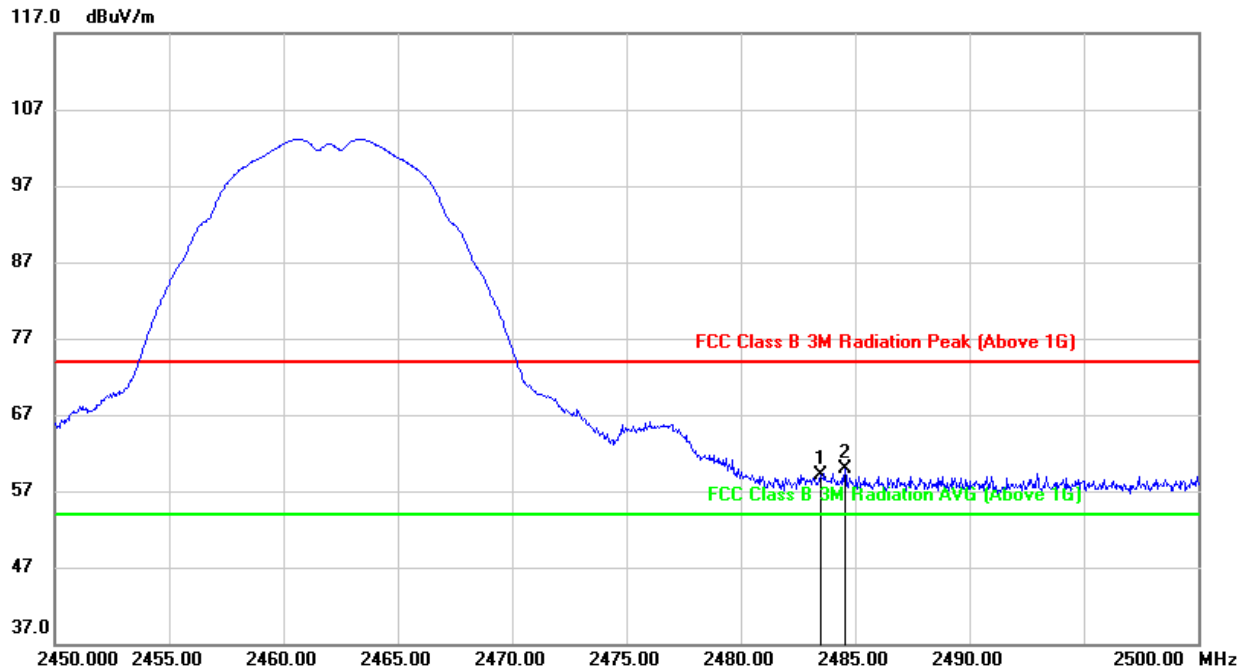

No.	Frequency (MHz)	Reading (dBuV)	Correct (dB/m)	Result (dBuV/m)	Limit (dBuV/m)	Margin (dB)	Remark
1	2483.500	25.60	33.58	59.18	74.00	-14.82	peak
2	2484.550	26.35	33.59	59.94	74.00	-14.06	peak

- Note: 1. Measurement = Reading Level + Correct Factor.
 2. If Peak Result complies with AV limit, AV Result is deemed to comply with AV limit.
 3. Peak: Peak detector.
 4. Only the worst case emission was recorded, if it complies with the limit, the other emissions deemed to comply with the limit.



AVG

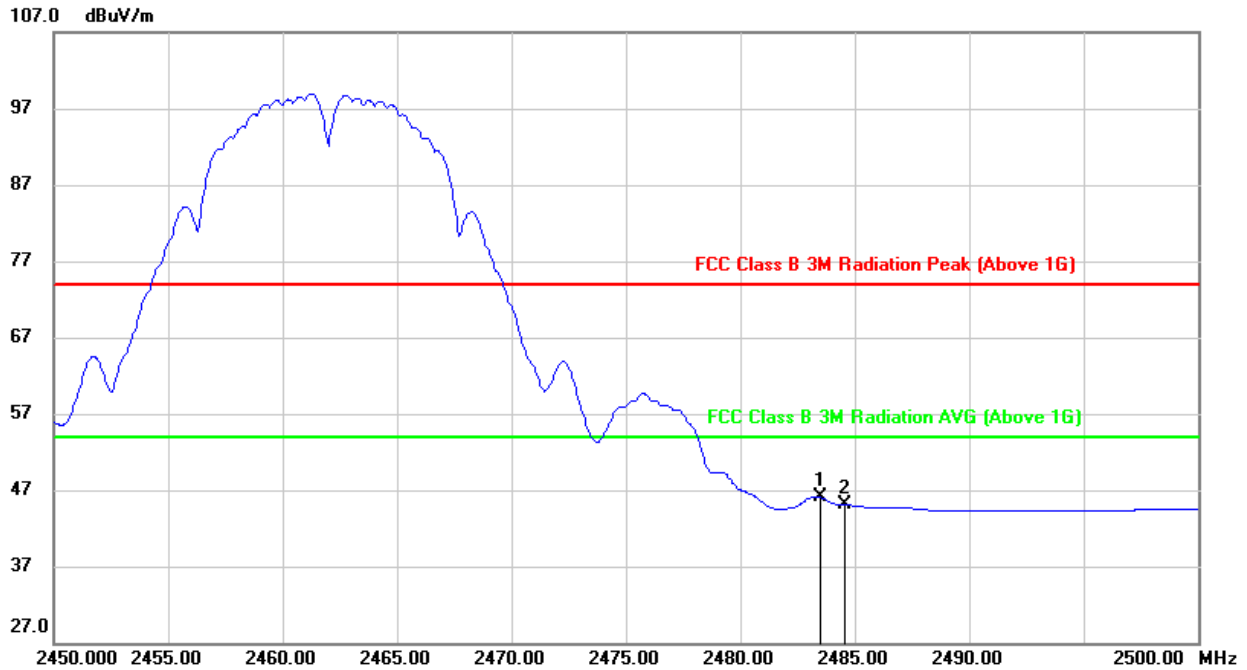

No.	Frequency (MHz)	Reading (dBuV)	Correct (dB/m)	Result (dBuV/m)	Limit (dBuV/m)	Margin (dB)	Remark
1	2483.500	12.52	33.58	46.10	54.00	-7.90	AVG
2	2484.550	11.48	33.59	45.07	54.00	-8.93	AVG

- Note: 1. Measurement = Reading Level + Correct Factor.
 2. If Peak Result complies with AV limit, AV Result is deemed to comply with AV limit.
 3. AVG: $VBW=1/T_{on}$ where: t_{on} is transmit duration.
 4. For transmit duration, please refer to clause 8.1.
 5. Only the worst case emission was recorded, if it complies with the limit, the other emissions deemed to comply with the limit.



9.1.2. 802.11g MODE

RESTRICTED BANDEDGE (LOW CHANNEL, HORIZONTAL)

PEAK

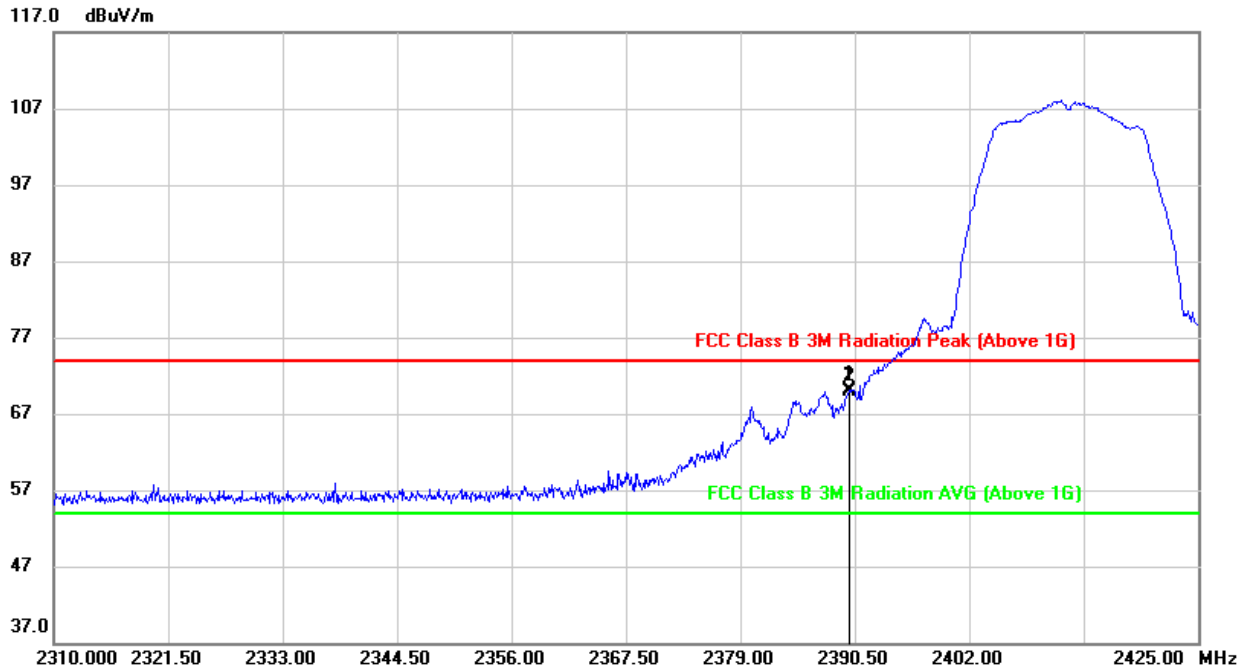

No.	Frequency (MHz)	Reading (dBuV)	Correct (dB/m)	Result (dBuV/m)	Limit (dBuV/m)	Margin (dB)	Remark
1	2389.925	37.10	32.94	70.04	74.00	-3.96	peak
2	2390.000	36.94	32.94	69.88	74.00	-4.12	peak

- Note: 1. Measurement = Reading Level + Correct Factor.
 2. If Peak Result complies with AV limit, AV Result is deemed to comply with AV limit.
 3. Peak: Peak detector.
 4. Only the worst case emission was recorded, if it complies with the limit, the other emissions deemed to comply with the limit.



AVG

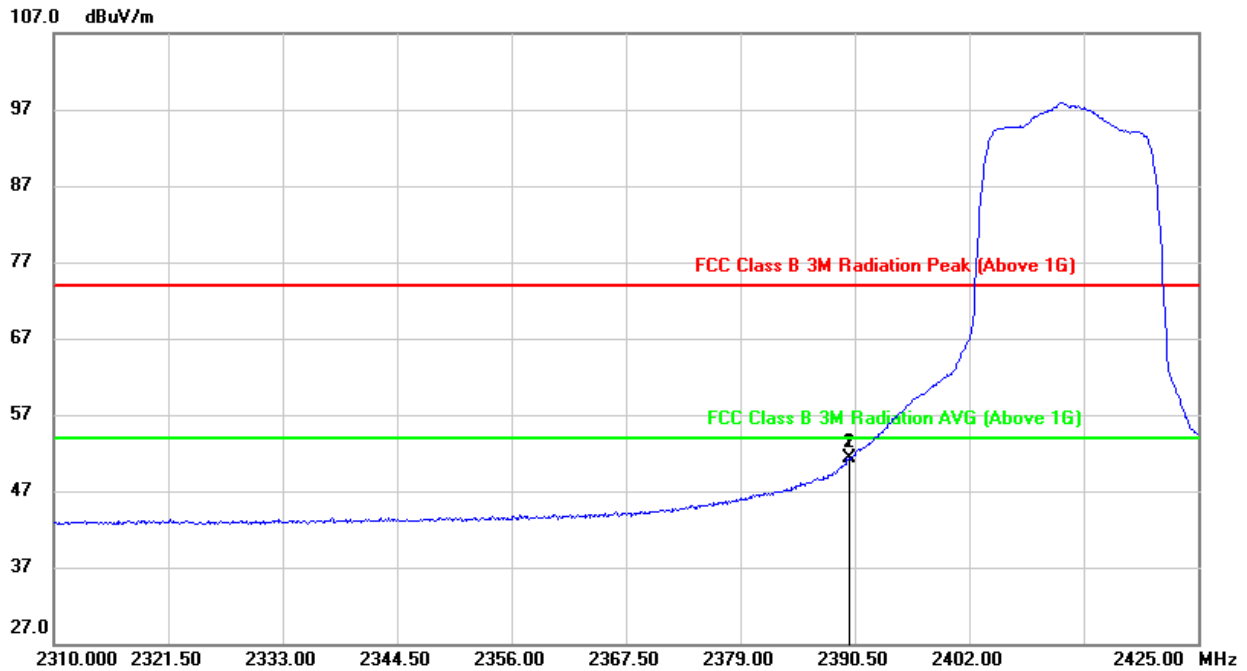

No.	Frequency (MHz)	Reading (dBuV)	Correct (dB/m)	Result (dBuV/m)	Limit (dBuV/m)	Margin (dB)	Remark
1	2389.925	18.36	32.94	51.30	54.00	-2.70	AVG
2	2390.000	18.35	32.94	51.29	54.00	-2.71	AVG

- Note: 1. Measurement = Reading Level + Correct Factor.
 2. If Peak Result complies with AV limit, AV Result is deemed to comply with AV limit.
 3. AVG: $VBW=1/Ton$ where: ton is transmit duration.
 4. For transmit duration, please refer to clause 8.1.
 5. Only the worst case emission was recorded, if it complies with the limit, the other emissions deemed to comply with the limit.



RESTRICTED BANDEDGE (LOW CHANNEL, VERTICAL)

PEAK

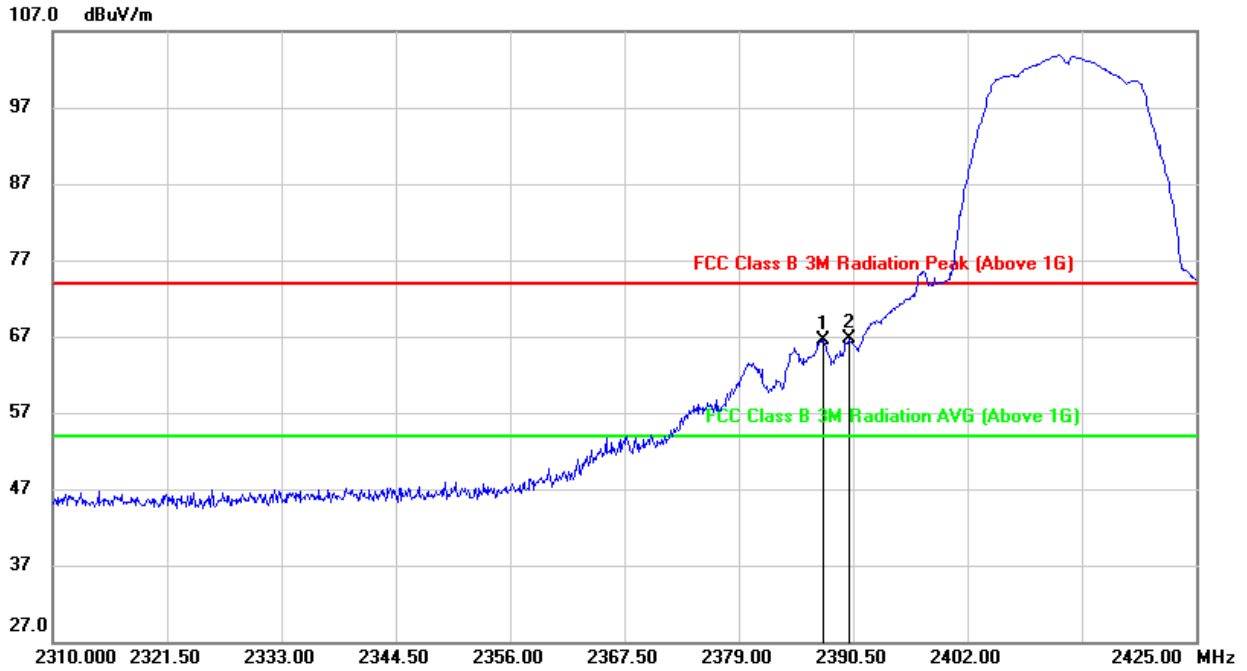

No.	Frequency (MHz)	Reading (dBuV)	Correct (dB/m)	Result (dBuV/m)	Limit (dBuV/m)	Margin (dB)	Remark
1	2387.510	33.61	32.94	66.55	74.00	-7.45	peak
2	2390.000	33.79	32.94	66.73	74.00	-7.27	peak

- Note: 1. Measurement = Reading Level + Correct Factor.
 2. If Peak Result complies with AV limit, AV Result is deemed to comply with AV limit.
 3. Peak: Peak detector.
 4. Only the worst case emission was recorded, if it complies with the limit, the other emissions deemed to comply with the limit.



AVG

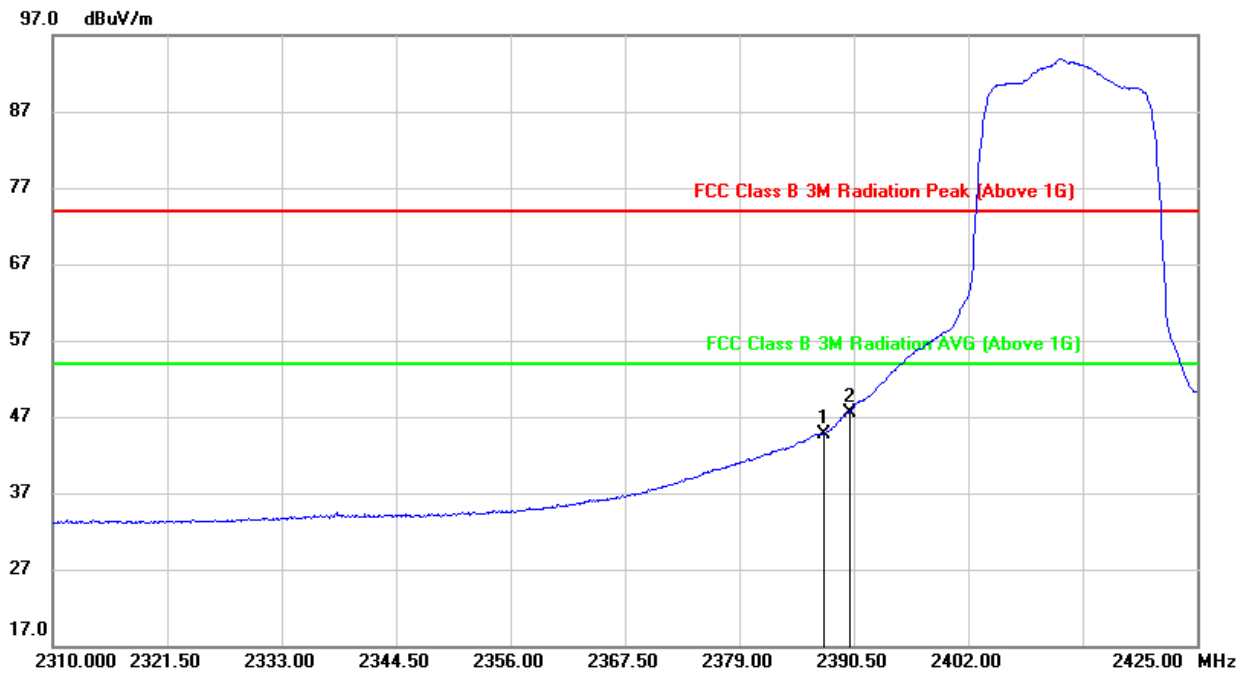

No.	Frequency (MHz)	Reading (dBuV)	Correct (dB/m)	Result (dBuV/m)	Limit (dBuV/m)	Margin (dB)	Remark
1	2387.510	11.84	32.94	44.78	54.00	-9.22	AVG
2	2390.000	14.65	32.94	47.59	54.00	-6.41	AVG

- Note:
1. Measurement = Reading Level + Correct Factor.
 2. If Peak Result complies with AV limit, AV Result is deemed to comply with AV limit.
 3. AVG: $VBW=1/T_{on}$ where: t_{on} is transmit duration.
 4. For transmit duration, please refer to clause 8.1.
 5. Only the worst case emission was recorded, if it complies with the limit, the other emissions deemed to comply with the limit.



RESTRICTED BANDEDGE (HIGH CHANNEL, HORIZONTAL)

PEAK

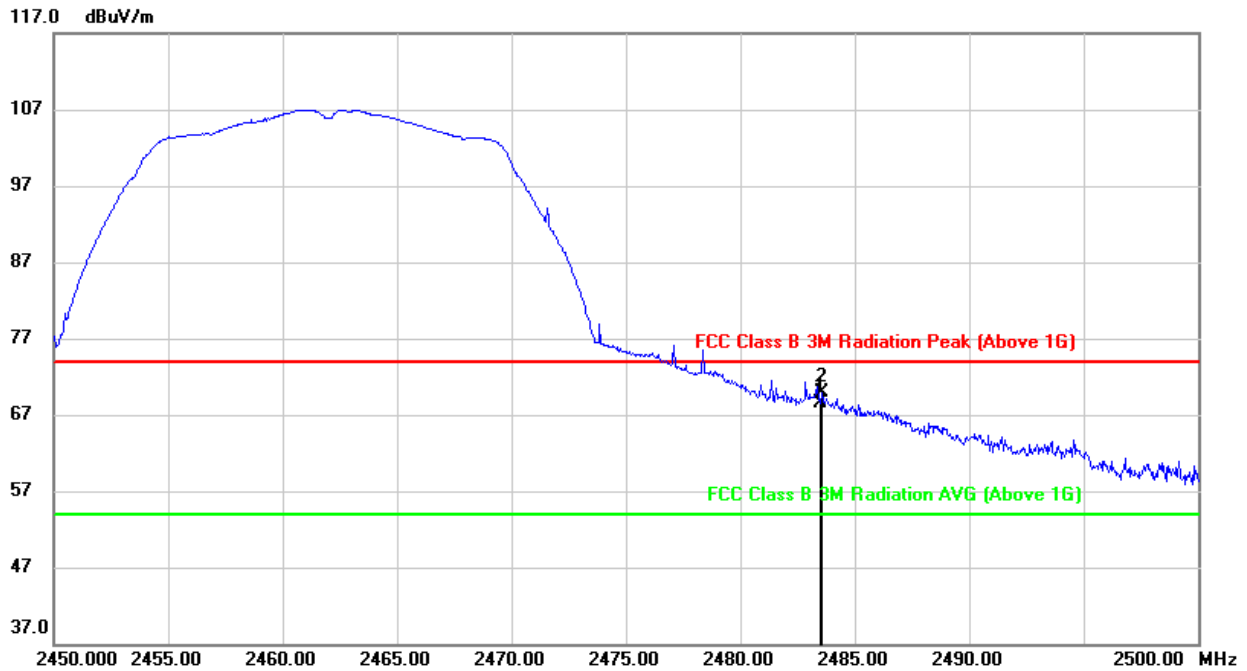

No.	Frequency (MHz)	Reading (dBuV)	Correct (dB/m)	Result (dBuV/m)	Limit (dBuV/m)	Margin (dB)	Remark
1	2483.500	35.00	33.58	68.58	74.00	-5.42	peak
2	2483.550	36.30	33.58	69.88	74.00	-4.12	peak

- Note: 1. Measurement = Reading Level + Correct Factor.
 2. If Peak Result complies with AV limit, AV Result is deemed to comply with AV limit.
 3. Peak: Peak detector.
 4. Only the worst case emission was recorded, if it complies with the limit, the other emissions deemed to comply with the limit.



AVG

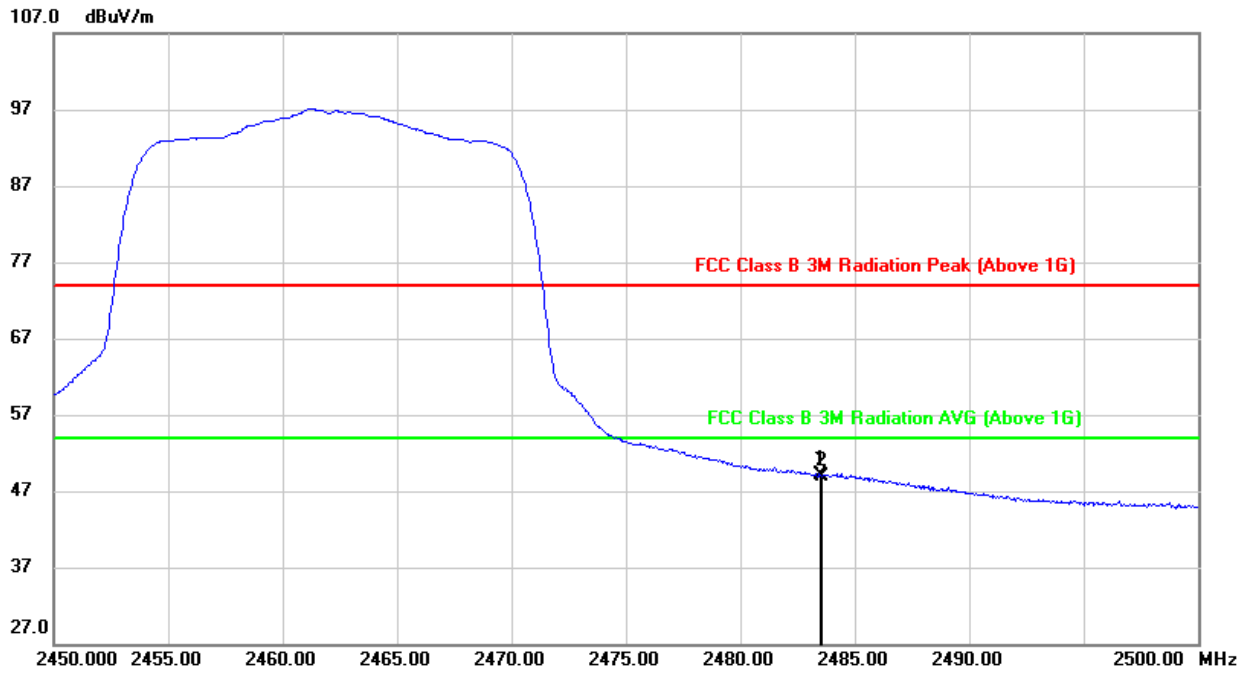

No.	Frequency (MHz)	Reading (dBuV)	Correct (dB/m)	Result (dBuV/m)	Limit (dBuV/m)	Margin (dB)	Remark
1	2483.500	15.48	33.58	49.06	54.00	-4.94	AVG
2	2483.550	15.34	33.58	48.92	54.00	-5.08	AVG

- Note:
1. Measurement = Reading Level + Correct Factor.
 2. If Peak Result complies with AV limit, AV Result is deemed to comply with AV limit.
 3. AVG: $VBW=1/T_{on}$ where: t_{on} is transmit duration.
 4. For transmit duration, please refer to clause 8.1.
 5. Only the worst case emission was recorded, if it complies with the limit, the other emissions deemed to comply with the limit.



RESTRICTED BANDEDGE (HIGH CHANNEL, VERTICAL)

PEAK

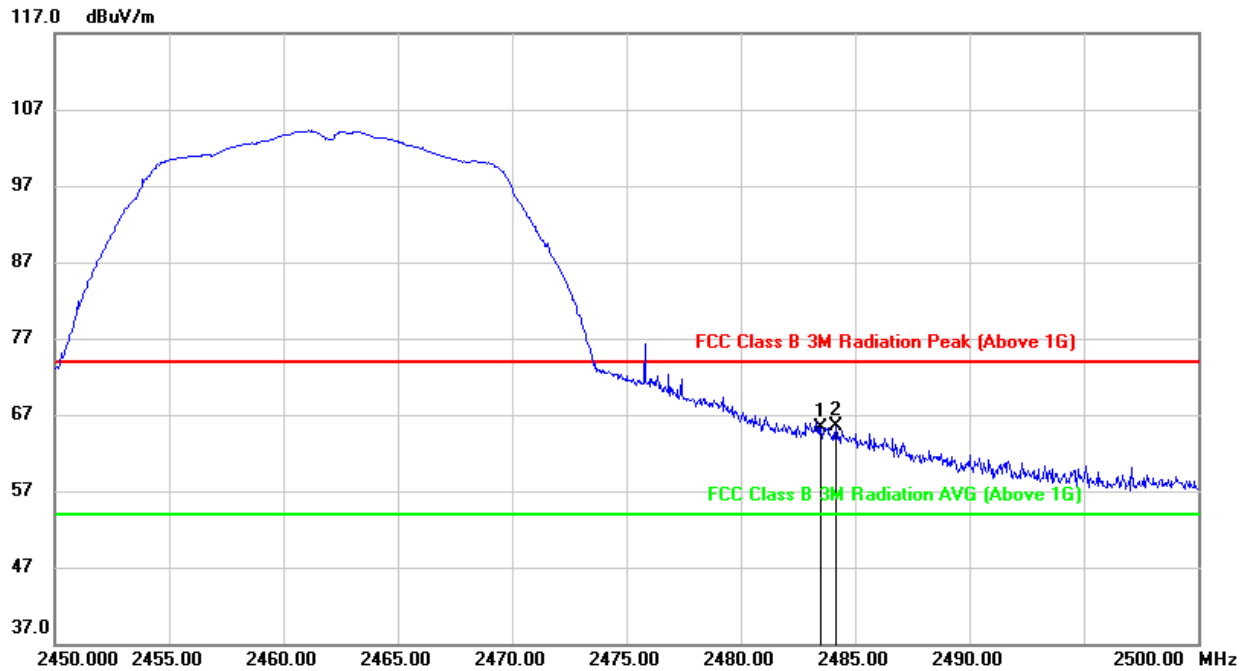

No.	Frequency (MHz)	Reading (dBuV)	Correct (dB/m)	Result (dBuV/m)	Limit (dBuV/m)	Margin (dB)	Remark
1	2483.500	31.63	33.58	65.21	74.00	-8.79	peak
2	2484.150	31.88	33.58	65.46	74.00	-8.54	peak

- Note: 1. Measurement = Reading Level + Correct Factor.
 2. If Peak Result complies with AV limit, AV Result is deemed to comply with AV limit.
 3. Peak: Peak detector.
 4. Only the worst case emission was recorded, if it complies with the limit, the other emissions deemed to comply with the limit.



AVG

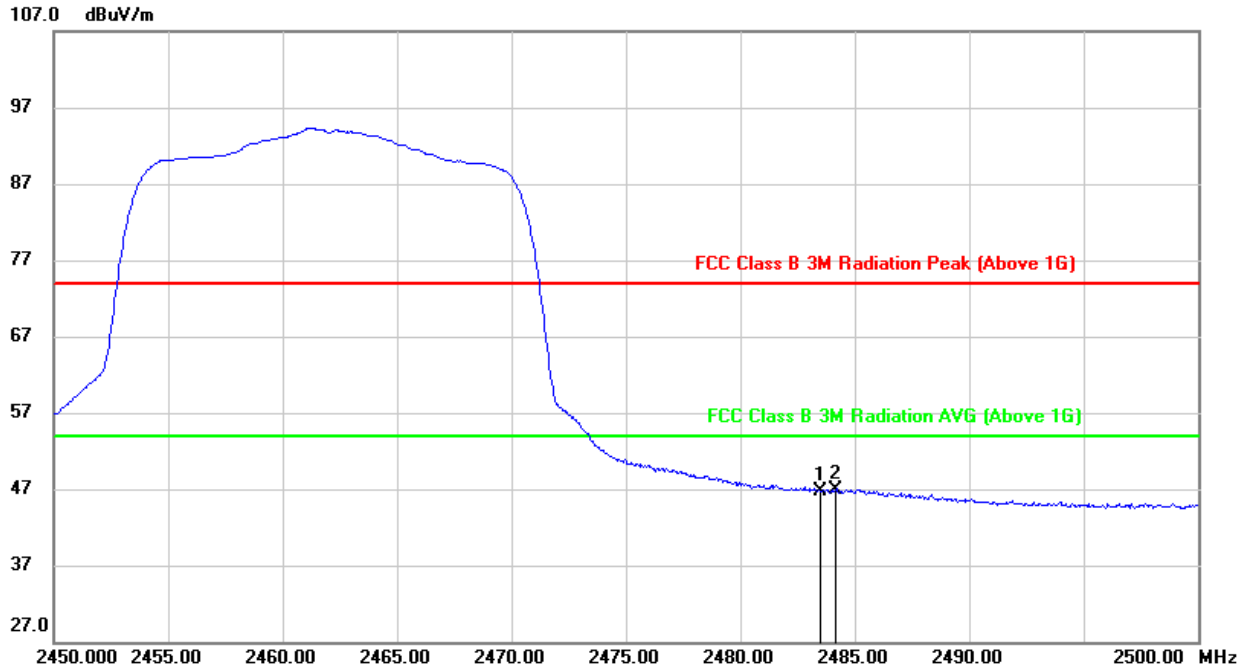

No.	Frequency (MHz)	Reading (dBuV)	Correct (dB/m)	Result (dBuV/m)	Limit (dBuV/m)	Margin (dB)	Remark
1	2483.500	13.21	33.58	46.79	54.00	-7.21	AVG
2	2484.150	13.32	33.58	46.90	54.00	-7.10	AVG

- Note: 1. Measurement = Reading Level + Correct Factor.
 2. If Peak Result complies with AV limit, AV Result is deemed to comply with AV limit.
 3. AVG: $VBW=1/Ton$ where: ton is transmit duration.
 4. For transmit duration, please refer to clause 8.1.
 5. Only the worst case emission was recorded, if it complies with the limit, the other emissions deemed to comply with the limit.



9.1.3. 802.11n HT20 MODE

RESTRICTED BANDEDGE (LOW CHANNEL, HORIZONTAL)

PEAK

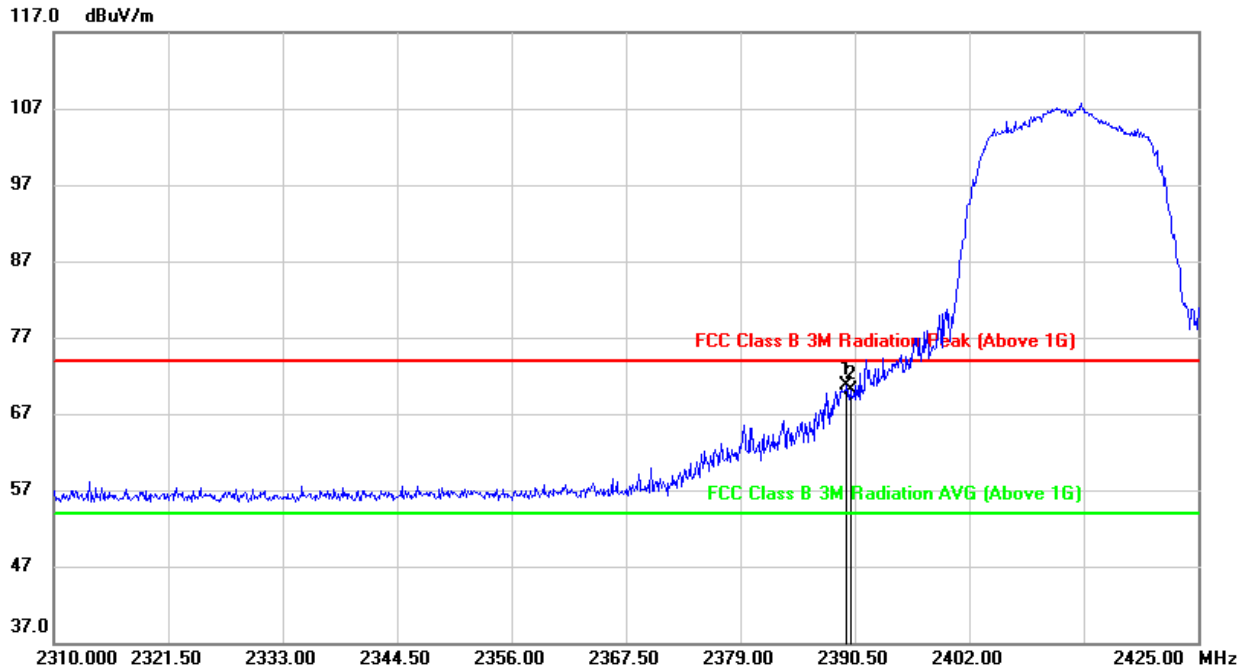

No.	Frequency (MHz)	Reading (dBuV)	Correct (dB/m)	Result (dBuV/m)	Limit (dBuV/m)	Margin (dB)	Remark
1	2389.695	37.75	32.94	70.69	74.00	-3.31	peak
2	2390.000	37.13	32.94	70.07	74.00	-3.93	peak

- Note: 1. Measurement = Reading Level + Correct Factor.
 2. If Peak Result complies with AV limit, AV Result is deemed to comply with AV limit.
 3. Peak: Peak detector.
 4. Only the worst case emission was recorded, if it complies with the limit, the other emissions deemed to comply with the limit.



AVG

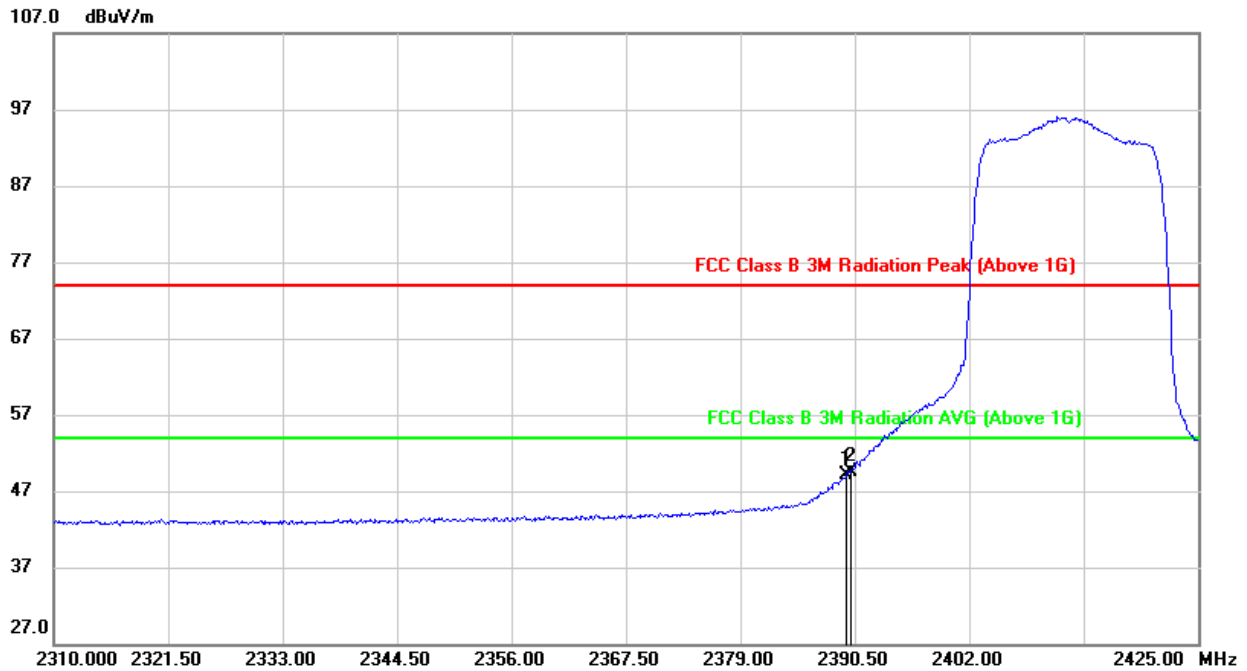

No.	Frequency (MHz)	Reading (dBuV)	Correct (dB/m)	Result (dBuV/m)	Limit (dBuV/m)	Margin (dB)	Remark
1	2389.695	16.11	32.94	49.05	54.00	-4.95	AVG
2	2390.000	16.60	32.94	49.54	54.00	-4.46	AVG

- Note: 1. Measurement = Reading Level + Correct Factor.
 2. If Peak Result complies with AV limit, AV Result is deemed to comply with AV limit.
 3. AVG: $VBW=1/T_{on}$ where: t_{on} is transmit duration.
 4. For transmit duration, please refer to clause 8.1.
 5. Only the worst case emission was recorded, if it complies with the limit, the other emissions deemed to comply with the limit.



RESTRICTED BANDEDGE (LOW CHANNEL, VERTICAL)

PEAK

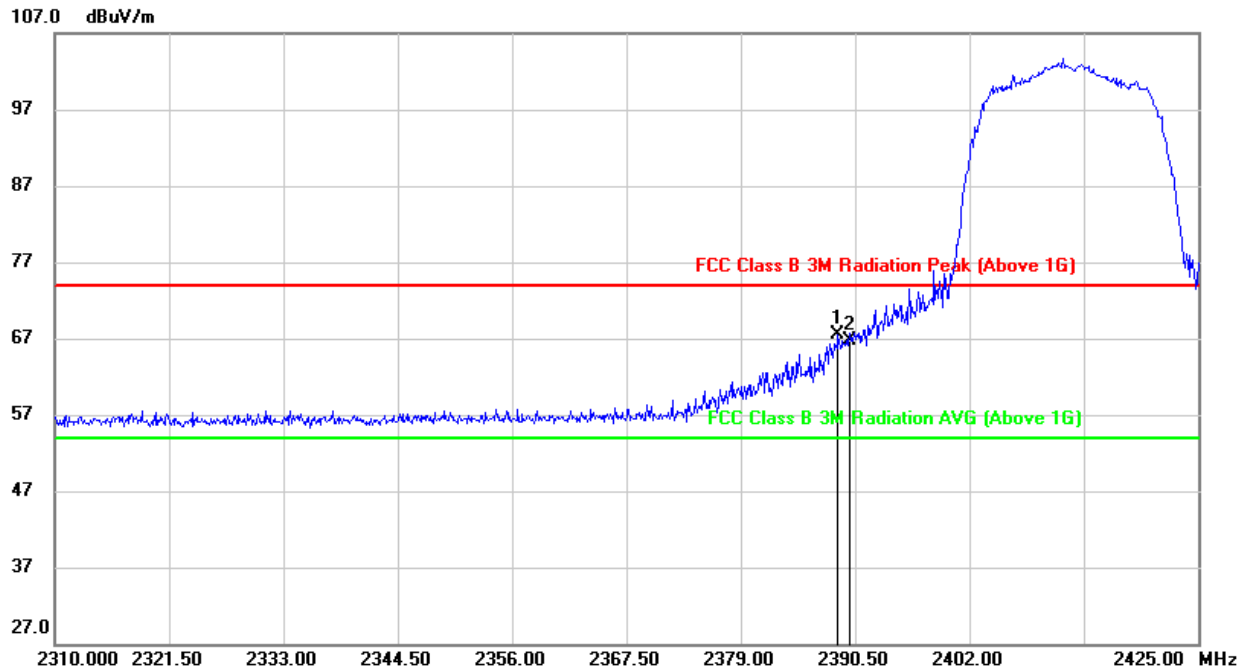

No.	Frequency (MHz)	Reading (dBuV)	Correct (dB/m)	Result (dBuV/m)	Limit (dBuV/m)	Margin (dB)	Remark
1	2388.775	34.53	32.94	67.47	74.00	-6.53	peak
2	2390.000	33.73	32.94	66.67	74.00	-7.33	peak

- Note: 1. Measurement = Reading Level + Correct Factor.
 2. If Peak Result complies with AV limit, AV Result is deemed to comply with AV limit.
 3. Peak: Peak detector.
 4. Only the worst case emission was recorded, if it complies with the limit, the other emissions deemed to comply with the limit.



AVG

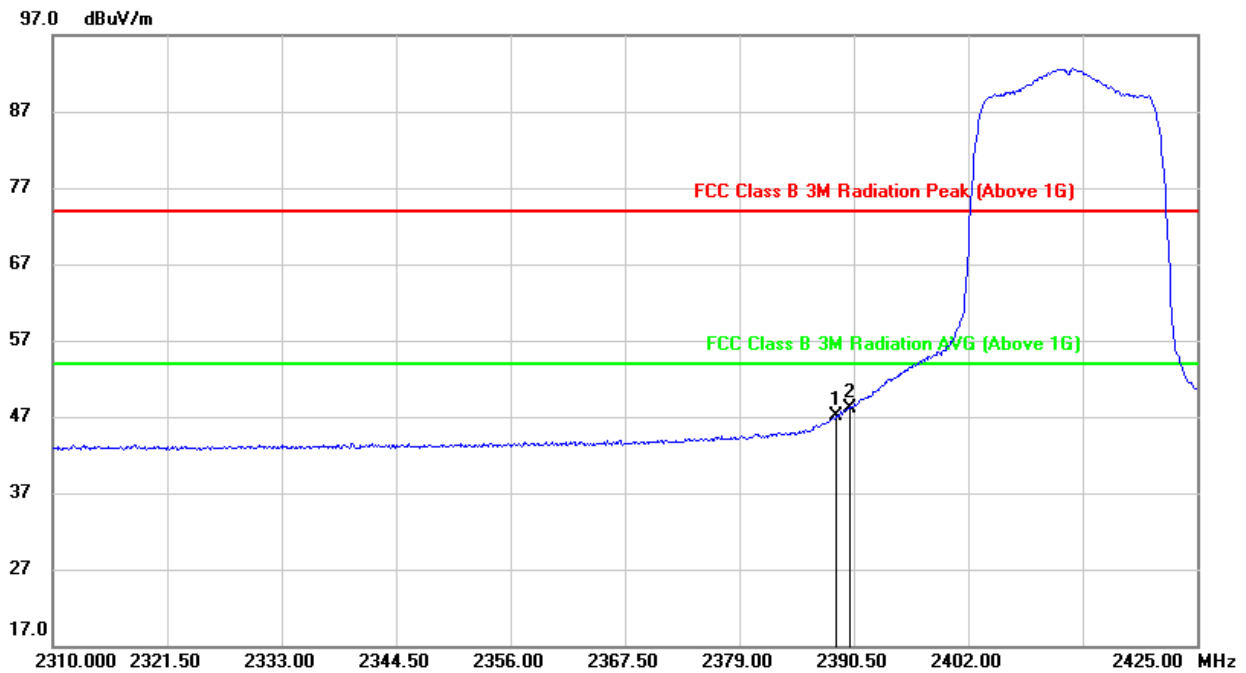

No.	Frequency (MHz)	Reading (dBuV)	Correct (dB/m)	Result (dBuV/m)	Limit (dBuV/m)	Margin (dB)	Remark
1	2388.775	14.17	32.94	47.11	54.00	-6.89	AVG
2	2390.000	15.20	32.94	48.14	54.00	-5.86	AVG

- Note:
1. Measurement = Reading Level + Correct Factor.
 2. If Peak Result complies with AV limit, AV Result is deemed to comply with AV limit.
 3. AVG: $VBW=1/T_{on}$ where: t_{on} is transmit duration.
 4. For transmit duration, please refer to clause 8.1.
 5. Only the worst case emission was recorded, if it complies with the limit, the other emissions deemed to comply with the limit.



RESTRICTED BANDEDGE (HIGH CHANNEL, HORIZONTAL)

PEAK

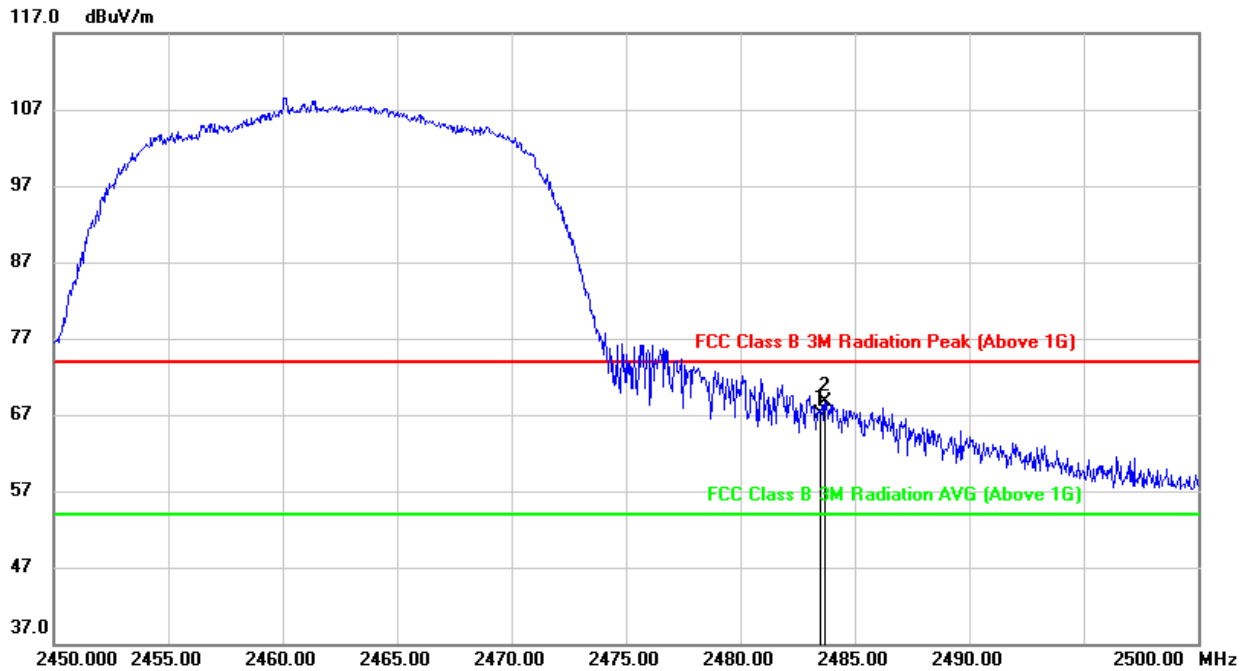

No.	Frequency (MHz)	Reading (dBuV)	Correct (dB/m)	Result (dBuV/m)	Limit (dBuV/m)	Margin (dB)	Remark
1	2483.500	33.58	33.58	67.16	74.00	-6.84	peak
2	2483.700	35.04	33.58	68.62	74.00	-5.38	peak

- Note: 1. Measurement = Reading Level + Correct Factor.
 2. If Peak Result complies with AV limit, AV Result is deemed to comply with AV limit.
 3. Peak: Peak detector.
 4. Only the worst case emission was recorded, if it complies with the limit, the other emissions deemed to comply with the limit.



AVG

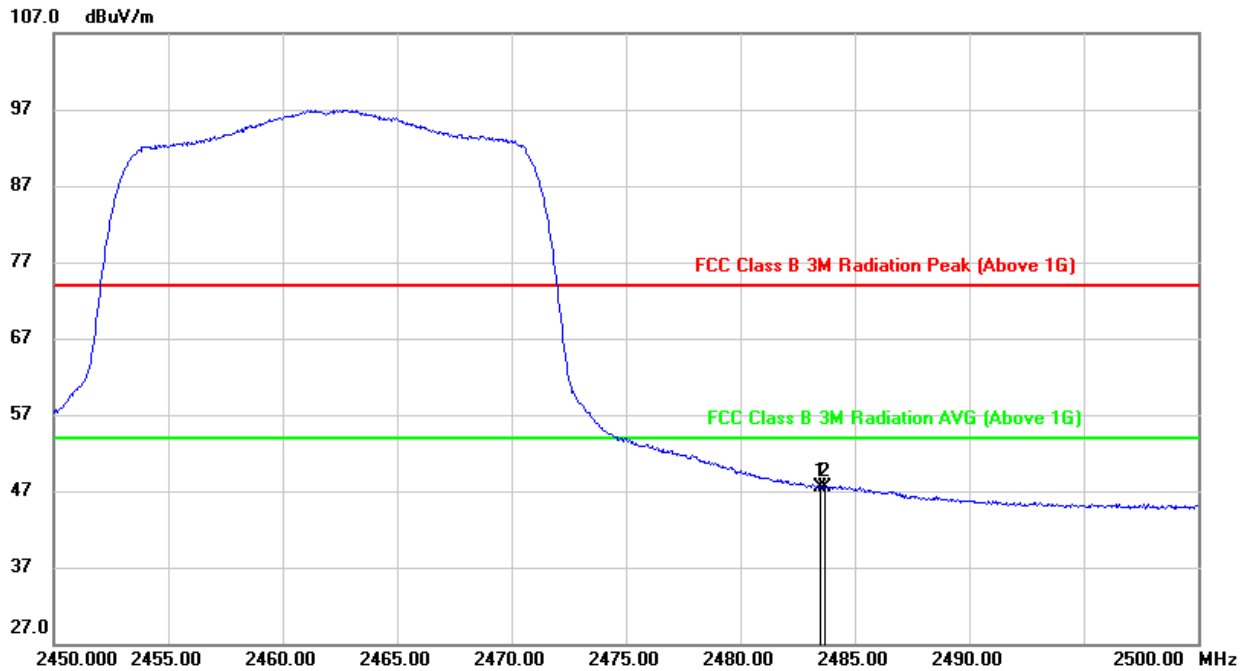

No.	Frequency (MHz)	Reading (dBuV)	Correct (dB/m)	Result (dBuV/m)	Limit (dBuV/m)	Margin (dB)	Remark
1	2483.500	13.87	33.58	47.45	54.00	-6.55	AVG
2	2483.700	13.87	33.58	47.45	54.00	-6.55	AVG

- Note: 1. Measurement = Reading Level + Correct Factor.
 2. If Peak Result complies with AV limit, AV Result is deemed to comply with AV limit.
 3. AVG: $VBW=1/T_{on}$ where: t_{on} is transmit duration.
 4. For transmit duration, please refer to clause 8.1.
 5. Only the worst case emission was recorded, if it complies with the limit, the other emissions deemed to comply with the limit.



RESTRICTED BANDEDGE (HIGH CHANNEL, VERTICAL)

PEAK

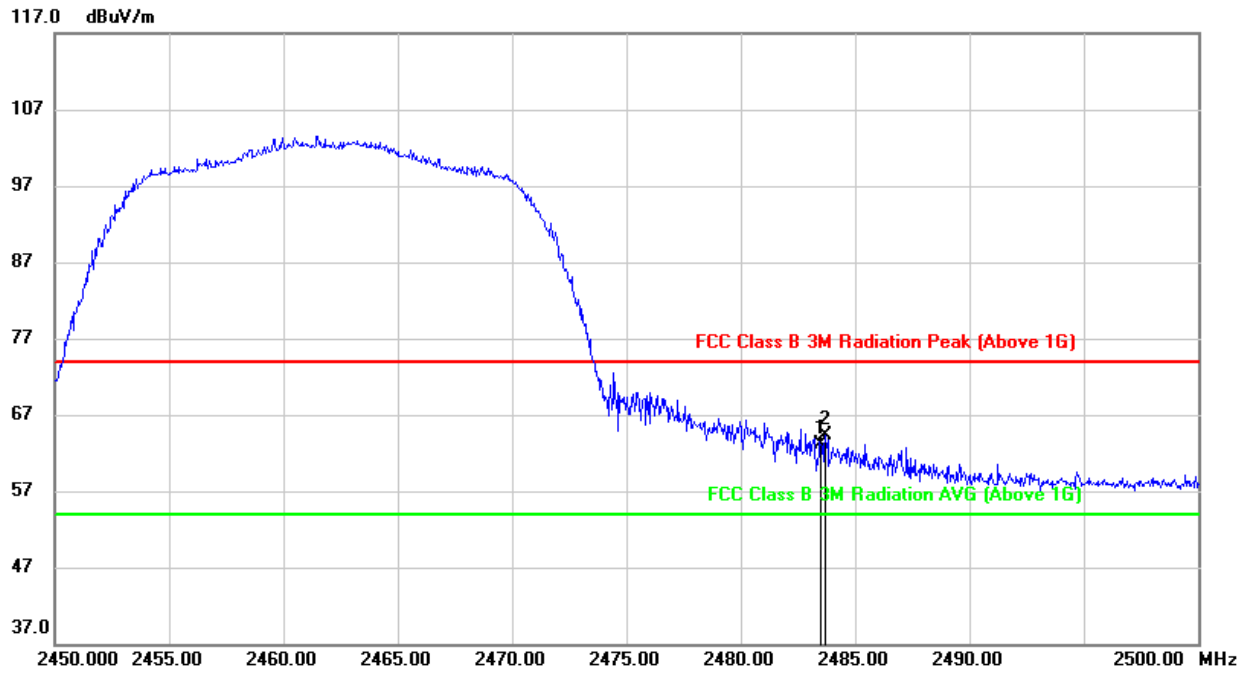

No.	Frequency (MHz)	Reading (dBuV)	Correct (dB/m)	Result (dBuV/m)	Limit (dBuV/m)	Margin (dB)	Remark
1	2483.500	29.50	33.58	63.08	74.00	-10.92	peak
2	2483.700	30.72	33.58	64.30	74.00	-9.70	peak

- Note: 1. Measurement = Reading Level + Correct Factor.
 2. If Peak Result complies with AV limit, AV Result is deemed to comply with AV limit.
 3. Peak: Peak detector.
 4. Only the worst case emission was recorded, if it complies with the limit, the other emissions deemed to comply with the limit.



AVG

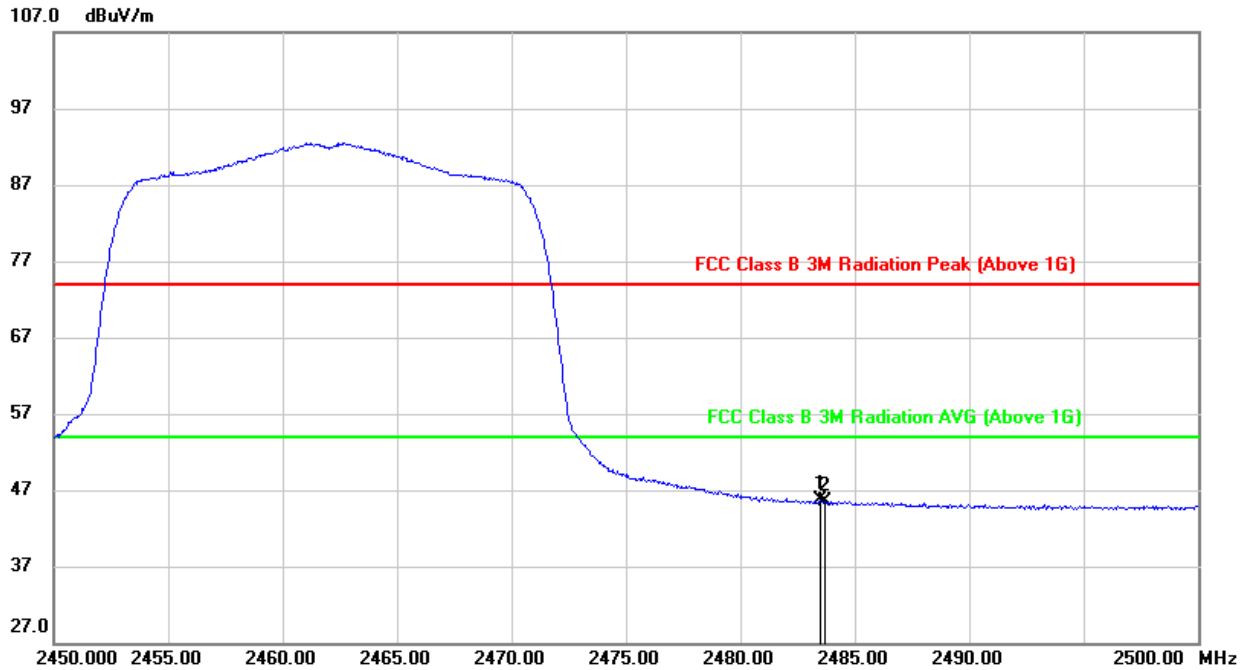

No.	Frequency (MHz)	Reading (dBuV)	Correct (dB/m)	Result (dBuV/m)	Limit (dBuV/m)	Margin (dB)	Remark
1	2483.500	12.16	33.58	45.74	54.00	-8.26	AVG
2	2483.700	11.83	33.58	45.41	54.00	-8.59	AVG

- Note: 1. Measurement = Reading Level + Correct Factor.
 2. If Peak Result complies with AV limit, AV Result is deemed to comply with AV limit.
 3. AVG: $VBW=1/T_{on}$ where: t_{on} is transmit duration.
 4. For transmit duration, please refer to clause 8.1.
 5. Only the worst case emission was recorded, if it complies with the limit, the other emissions deemed to comply with the limit.



9.2. SPURIOUS EMISSIONS (3~18GHz)

9.2.1. 802.11b MODE

HARMONICS AND SPURIOUS EMISSIONS (LOW CHANNEL, HORIZONTAL)

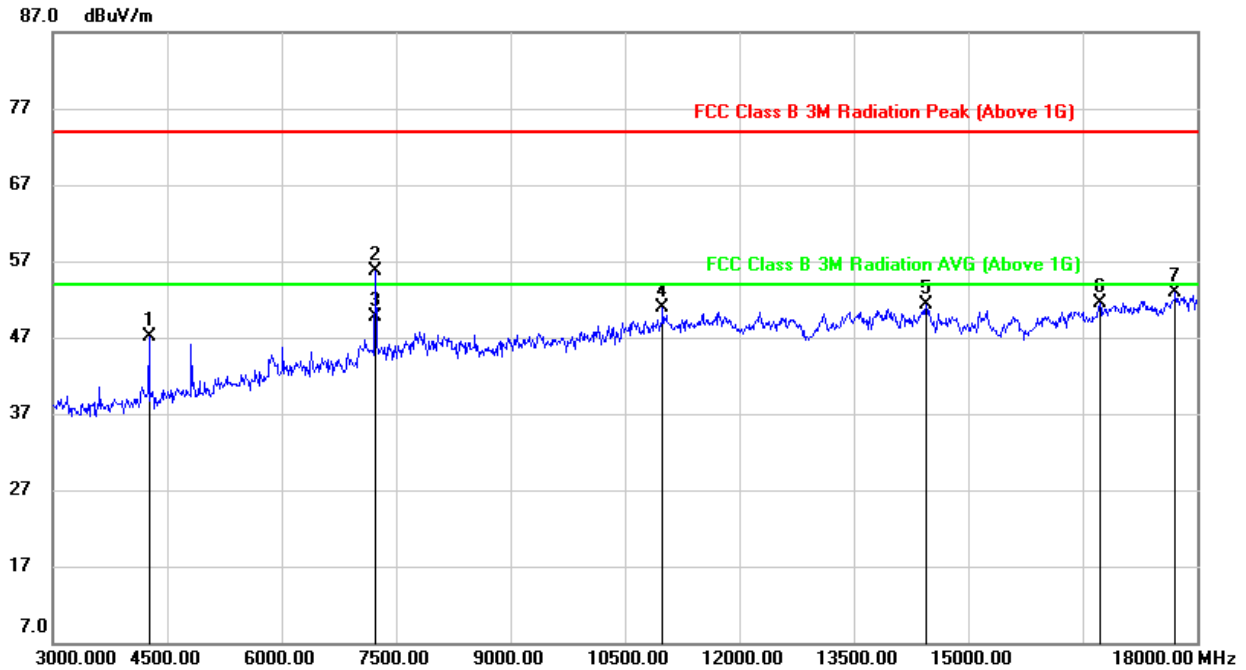

No.	Frequency (MHz)	Reading (dBuV)	Correct (dB/m)	Result (dBuV/m)	Limit (dBuV/m)	Margin (dB)	Remark
1	4260.000	48.97	-1.84	47.13	74.00	-26.87	peak
2	7235.294	48.51	7.14	55.65	74.00	-18.35	peak
3	7235.294	42.66	7.14	49.80	54.00	-4.20	AVG
4	10995.000	37.36	13.62	50.98	74.00	-23.02	peak
5	14445.000	34.57	16.66	51.23	74.00	-22.77	peak
6	16725.000	31.25	20.24	51.49	74.00	-22.51	peak
7	17715.000	30.34	22.65	52.99	74.00	-21.01	peak

- Note: 1. Measurement = Reading Level + Correct Factor.
 2. If Peak Result complies with AV limit, AV Result is deemed to comply with AV limit.
 3. Peak: Peak detector.
 4. AVG: VBW=1/Ton where: ton is transmit duration.
 5. For transmit duration, please refer to clause 8.1.
 6. Filter losses were only considered in the spurious frequency bands and the authorized band was not corrected for HPF losses.
 7. Proper operation of the transmitter prior to adding the filter to the measurement chain.





HARMONICS AND SPURIOUS EMISSIONS (LOW CHANNEL, VERTICAL)

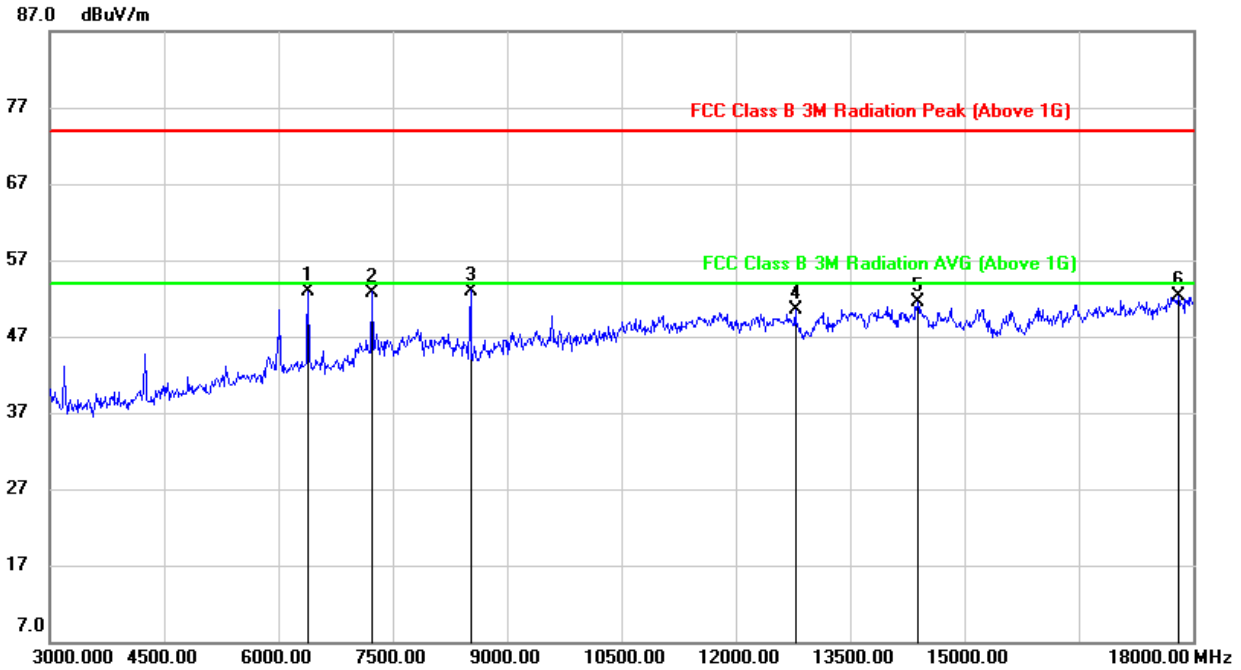

No.	Frequency (MHz)	Reading (dBuV)	Correct (dB/m)	Result (dBuV/m)	Limit (dBuV/m)	Margin (dB)	Remark
1	6390.000	47.83	5.15	52.98	74.00	-21.02	peak
2	7230.000	45.67	7.13	52.80	74.00	-21.20	peak
3	8520.000	44.24	8.76	53.00	74.00	-21.00	peak
4	12780.000	34.87	15.66	50.53	74.00	-23.47	peak
5	14385.000	34.75	16.67	51.42	74.00	-22.58	peak
6	17805.000	28.87	23.34	52.21	74.00	-21.79	peak

- Note: 1. Measurement = Reading Level + Correct Factor.
 2. If Peak Result complies with AV limit, AV Result is deemed to comply with AV limit.
 3. Peak: Peak detector.
 4. Filter losses were only considered in the spurious frequency bands and the authorized band was not corrected for HPF losses.
 5. Proper operation of the transmitter prior to adding the filter to the measurement chain.



HARMONICS AND SPURIOUS EMISSIONS (MID CHANNEL, HORIZONTAL)

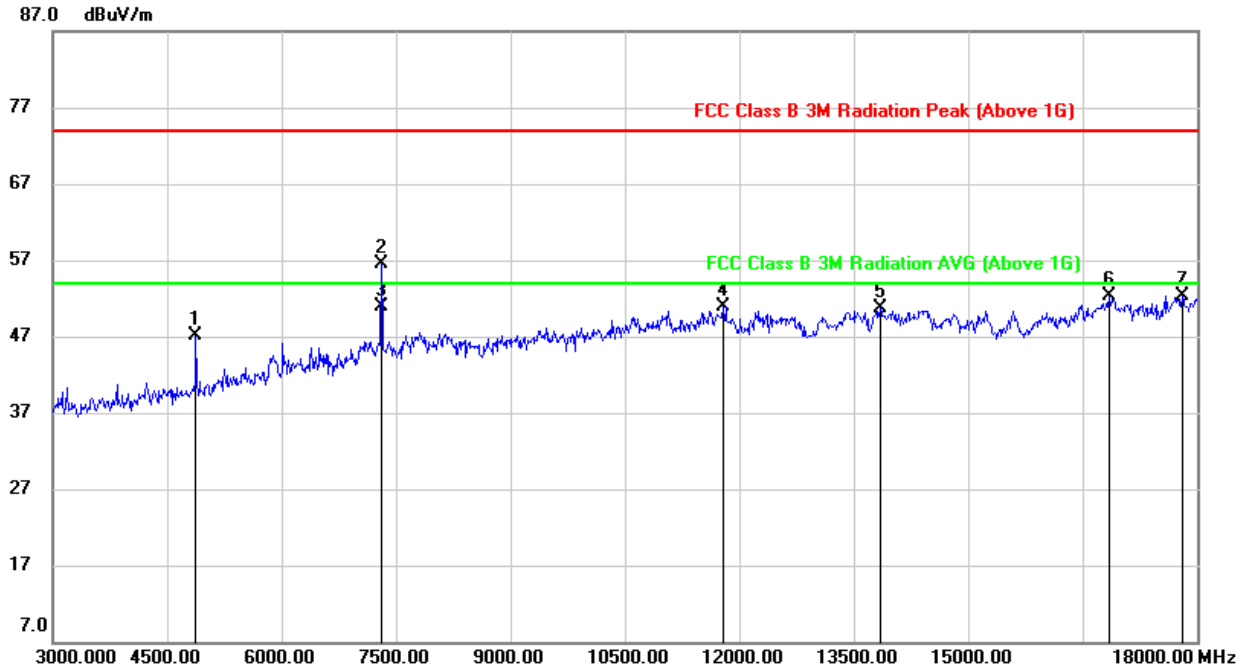

No.	Frequency (MHz)	Reading (dBuV)	Correct (dB/m)	Result (dBuV/m)	Limit (dBuV/m)	Margin (dB)	Remark
1	4875.000	47.04	0.10	47.14	74.00	-26.86	peak
2	7311.773	49.04	7.39	56.43	74.00	-17.57	peak
3	7311.773	43.43	7.39	50.82	54.00	-3.18	AVG
4	11790.000	36.67	14.28	50.95	74.00	-23.05	peak
5	13845.000	33.40	17.22	50.62	74.00	-23.38	peak
6	16845.000	31.95	20.33	52.28	74.00	-21.72	peak
7	17805.000	29.05	23.34	52.39	74.00	-21.61	peak

- Note: 1. Measurement = Reading Level + Correct Factor.
 2. If Peak Result complies with AV limit, AV Result is deemed to comply with AV limit.
 3. Peak: Peak detector.
 4. AVG: $VBW=1/Ton$ where: ton is transmit duration.
 5. For transmit duration, please refer to clause 8.1.
 6. Filter losses were only considered in the spurious frequency bands and the authorized band was not corrected for HPF losses.
 7. Proper operation of the transmitter prior to adding the filter to the measurement chain.



HARMONICS AND SPURIOUS EMISSIONS (MID CHANNEL, VERTICAL)

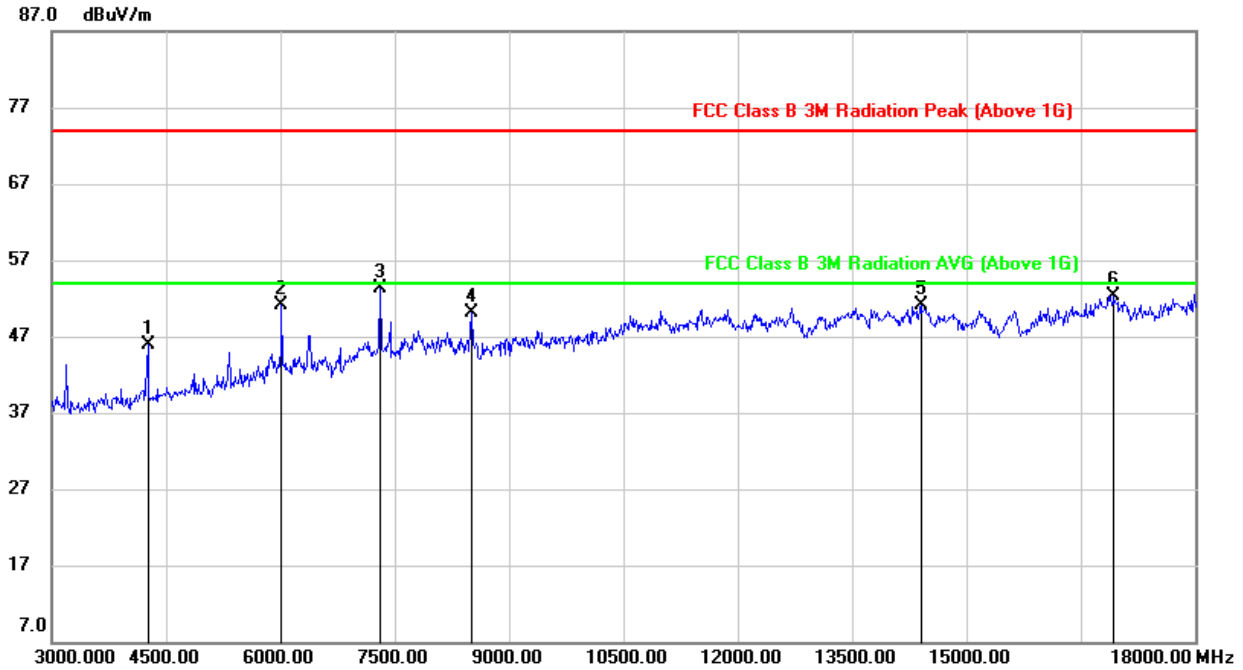

No.	Frequency (MHz)	Reading (dBuV)	Correct (dB/m)	Result (dBuV/m)	Limit (dBuV/m)	Margin (dB)	Remark
1	4260.000	47.71	-1.84	45.87	74.00	-28.13	peak
2	6015.000	47.05	4.01	51.06	74.00	-22.94	peak
3	7305.000	46.00	7.35	53.35	74.00	-20.65	peak
4	8505.000	41.33	8.77	50.10	74.00	-23.90	peak
5	14400.000	34.36	16.68	51.04	74.00	-22.96	peak
6	16935.000	31.80	20.53	52.33	74.00	-21.67	peak

- Note: 1. Measurement = Reading Level + Correct Factor.
 2. If Peak Result complies with AV limit, AV Result is deemed to comply with AV limit.
 3. Peak: Peak detector.
 4. Filter losses were only considered in the spurious frequency bands and the authorized band was not corrected for HPF losses.
 5. Proper operation of the transmitter prior to adding the filter to the measurement chain.



HARMONICS AND SPURIOUS EMISSIONS (HIGH CHANNEL, HORIZONTAL)

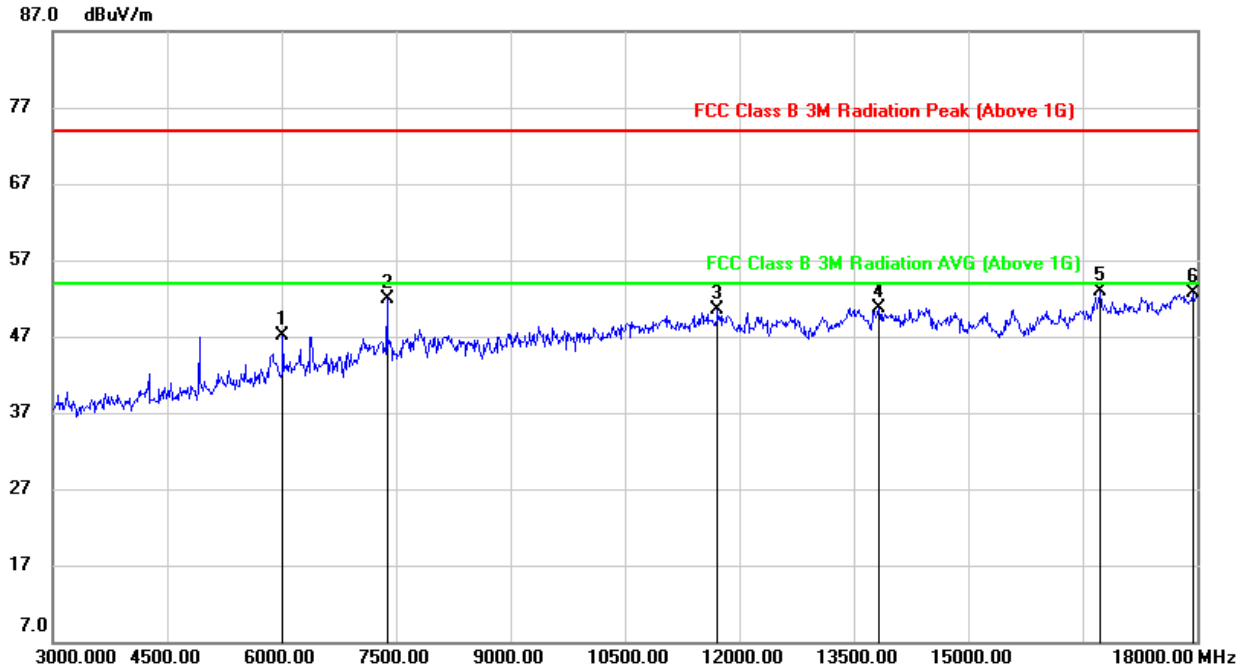

No.	Frequency (MHz)	Reading (dBuV)	Correct (dB/m)	Result (dBuV/m)	Limit (dBuV/m)	Margin (dB)	Remark
1	6015.000	43.14	4.01	47.15	74.00	-26.85	peak
2	7380.000	44.11	7.71	51.82	74.00	-22.18	peak
3	11715.000	36.39	14.09	50.48	74.00	-23.52	peak
4	13830.000	33.37	17.36	50.73	74.00	-23.27	peak
5	16725.000	32.59	20.24	52.83	74.00	-21.17	peak
6	17940.000	29.36	23.37	52.73	74.00	-21.27	peak

- Note: 1. Measurement = Reading Level + Correct Factor.
 2. If Peak Result complies with AV limit, AV Result is deemed to comply with AV limit.
 3. Peak: Peak detector.
 4. Filter losses were only considered in the spurious frequency bands and the authorized band was not corrected for HPF losses.
 5. Proper operation of the transmitter prior to adding the filter to the measurement chain.



HARMONICS AND SPURIOUS EMISSIONS (HIGH CHANNEL, VERTICAL)

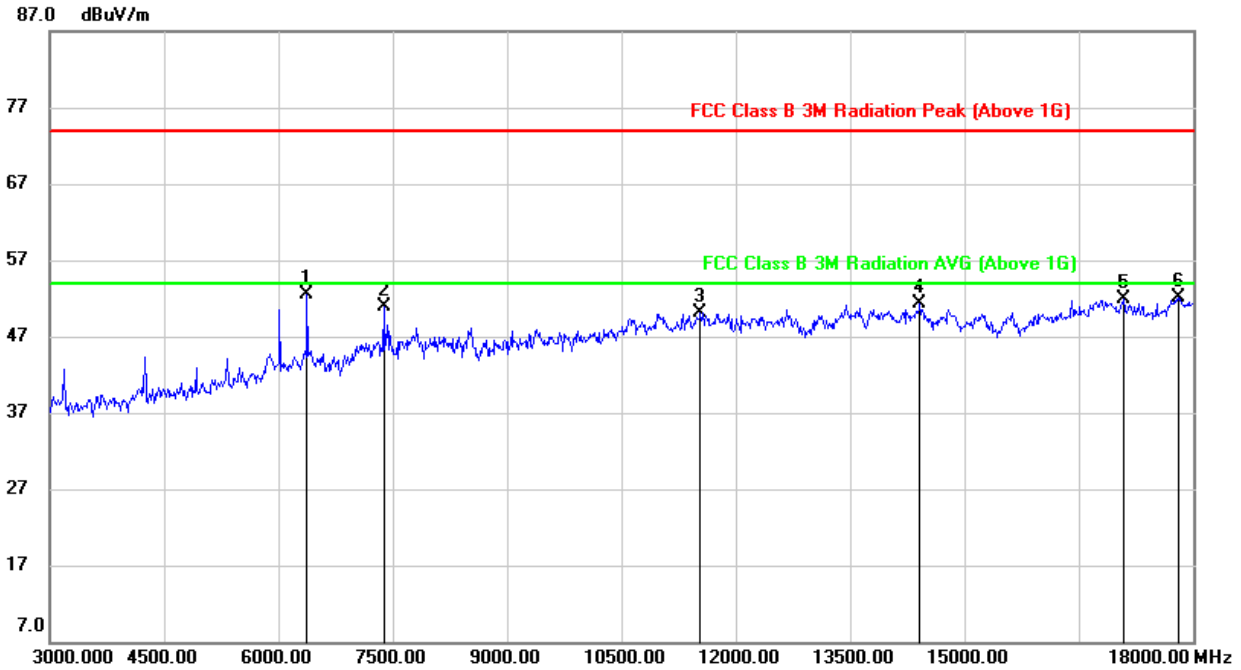

No.	Frequency (MHz)	Reading (dBuV)	Correct (dB/m)	Result (dBuV/m)	Limit (dBuV/m)	Margin (dB)	Remark
1	6375.000	47.45	5.08	52.53	74.00	-21.47	peak
2	7380.000	43.17	7.71	50.88	74.00	-23.12	peak
3	11535.000	35.76	14.41	50.17	74.00	-23.83	peak
4	14415.000	34.54	16.67	51.21	74.00	-22.79	peak
5	17085.000	30.81	21.01	51.82	74.00	-22.18	peak
6	17805.000	28.85	23.34	52.19	74.00	-21.81	peak

- Note: 1. Measurement = Reading Level + Correct Factor.
 2. If Peak Result complies with AV limit, AV Result is deemed to comply with AV limit.
 3. Peak: Peak detector.
 4. Filter losses were only considered in the spurious frequency bands and the authorized band was not corrected for HPF losses.
 5. Proper operation of the transmitter prior to adding the filter to the measurement chain.



9.2.2. 802.11g MODE

HARMONICS AND SPURIOUS EMISSIONS (LOW CHANNEL, HORIZONTAL)

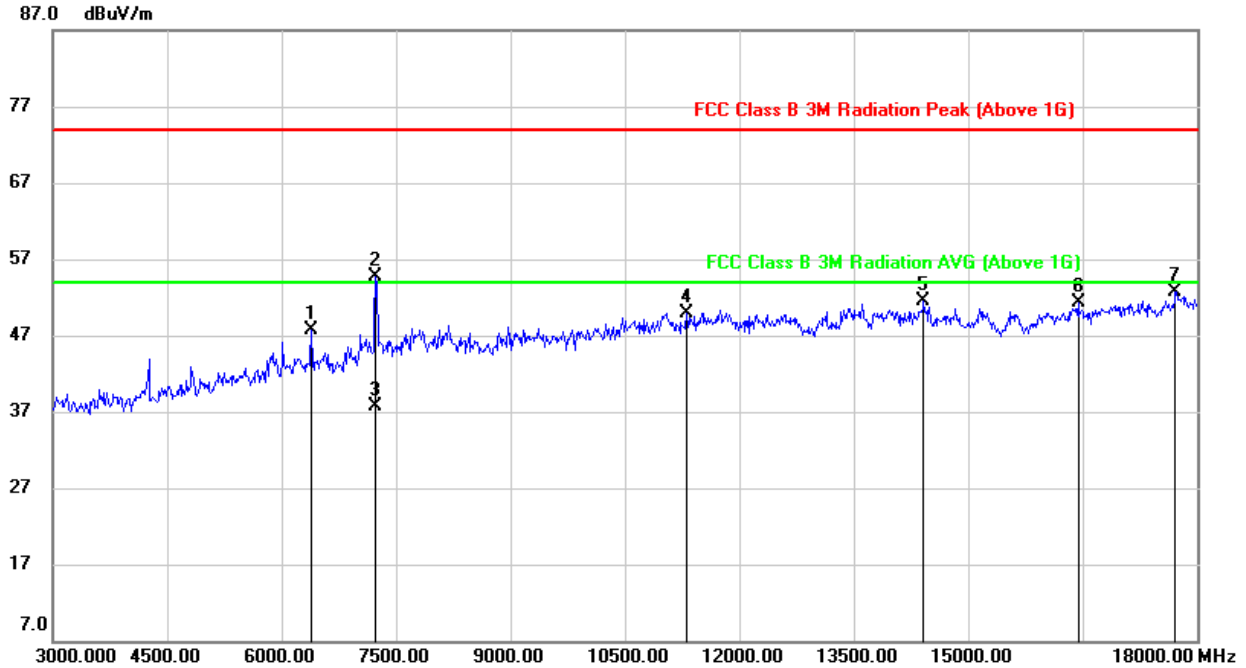

No.	Frequency (MHz)	Reading (dBuV)	Correct (dB/m)	Result (dBuV/m)	Limit (dBuV/m)	Margin (dB)	Remark
1	6390.000	42.59	5.15	47.74	74.00	-26.26	peak
2	7237.093	47.64	7.15	54.79	74.00	-19.21	peak
3	7237.093	30.54	7.15	37.69	54.00	-16.31	AVG
4	11310.000	36.55	13.42	49.97	74.00	-24.03	peak
5	14415.000	34.75	16.67	51.42	74.00	-22.58	peak
6	16440.000	32.26	19.09	51.35	74.00	-22.65	peak
7	17715.000	30.13	22.65	52.78	74.00	-21.22	peak

- Note:
1. Measurement = Reading Level + Correct Factor.
 2. If Peak Result complies with AV limit, AV Result is deemed to comply with AV limit.
 3. Peak: Peak detector.
 4. AVG: VBW=1/Ton where: ton is transmit duration.
 5. For transmit duration, please refer to clause 8.1.
 6. Filter losses were only considered in the spurious frequency bands and the authorized band was not corrected for HPF losses.
 7. Proper operation of the transmitter prior to adding the filter to the measurement chain.





HARMONICS AND SPURIOUS EMISSIONS (LOW CHANNEL, VERTICAL)

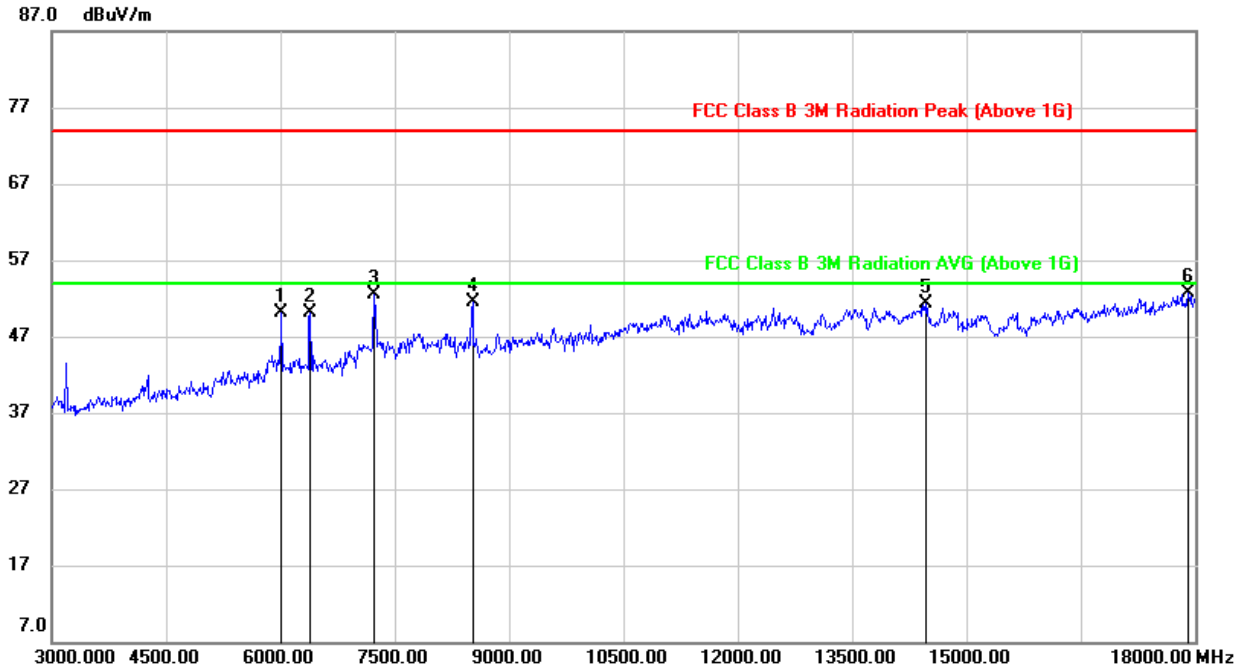

No.	Frequency (MHz)	Reading (dBuV)	Correct (dB/m)	Result (dBuV/m)	Limit (dBuV/m)	Margin (dB)	Remark
1	6015.000	46.01	4.01	50.02	74.00	-23.98	peak
2	6390.000	44.92	5.15	50.07	74.00	-23.93	peak
3	7230.000	45.32	7.13	52.45	74.00	-21.55	peak
4	8520.000	42.65	8.76	51.41	74.00	-22.59	peak
5	14475.000	34.62	16.64	51.26	74.00	-22.74	peak
6	17910.000	29.30	23.33	52.63	74.00	-21.37	peak

- Note: 1. Measurement = Reading Level + Correct Factor.
 2. If Peak Result complies with AV limit, AV Result is deemed to comply with AV limit.
 3. Peak: Peak detector.
 4. Filter losses were only considered in the spurious frequency bands and the authorized band was not corrected for HPF losses.
 5. Proper operation of the transmitter prior to adding the filter to the measurement chain.



HARMONICS AND SPURIOUS EMISSIONS (MID CHANNEL, HORIZONTAL)

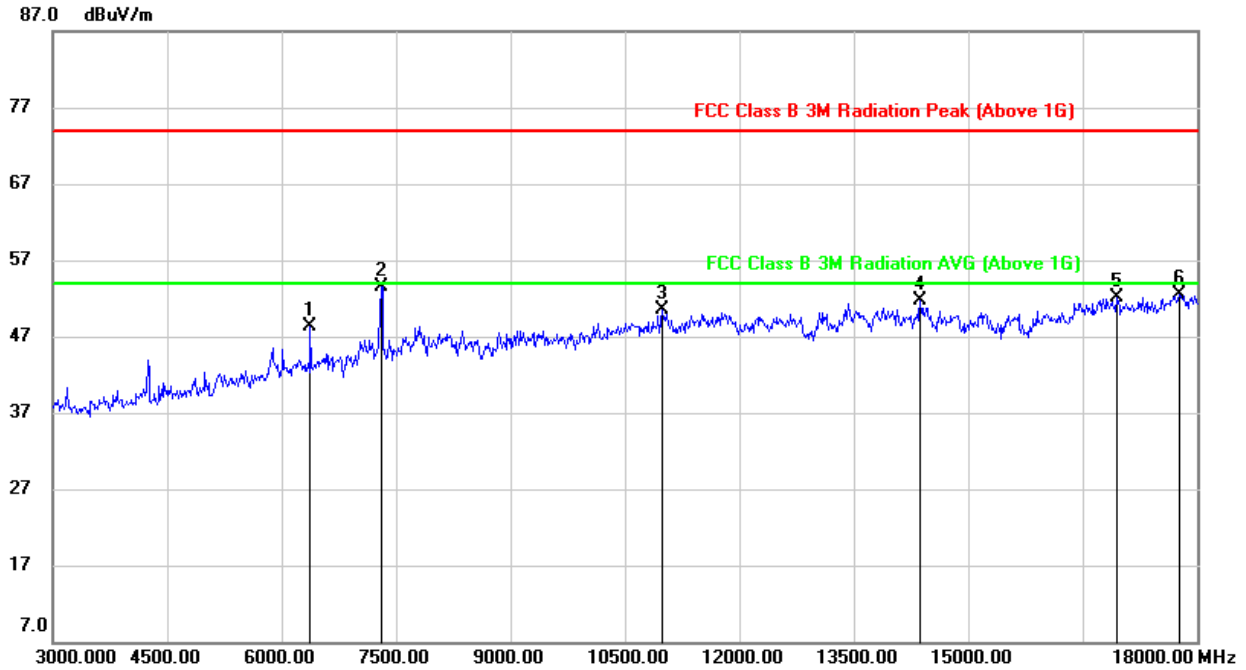

No.	Frequency (MHz)	Reading (dBuV)	Correct (dB/m)	Result (dBuV/m)	Limit (dBuV/m)	Margin (dB)	Remark
1	6375.000	43.16	5.08	48.24	74.00	-25.76	peak
2	7305.000	46.20	7.35	53.55	74.00	-20.45	peak
3	10980.000	37.00	13.47	50.47	74.00	-23.53	peak
4	14370.000	34.97	16.66	51.63	74.00	-22.37	peak
5	16950.000	31.40	20.61	52.01	74.00	-21.99	peak
6	17760.000	29.47	23.01	52.48	74.00	-21.52	peak

- Note: 1. Measurement = Reading Level + Correct Factor.
 2. If Peak Result complies with AV limit, AV Result is deemed to comply with AV limit.
 3. Peak: Peak detector.
 4. Filter losses were only considered in the spurious frequency bands and the authorized band was not corrected for HPF losses.
 5. Proper operation of the transmitter prior to adding the filter to the measurement chain.



HARMONICS AND SPURIOUS EMISSIONS (MID CHANNEL, VERTICAL)

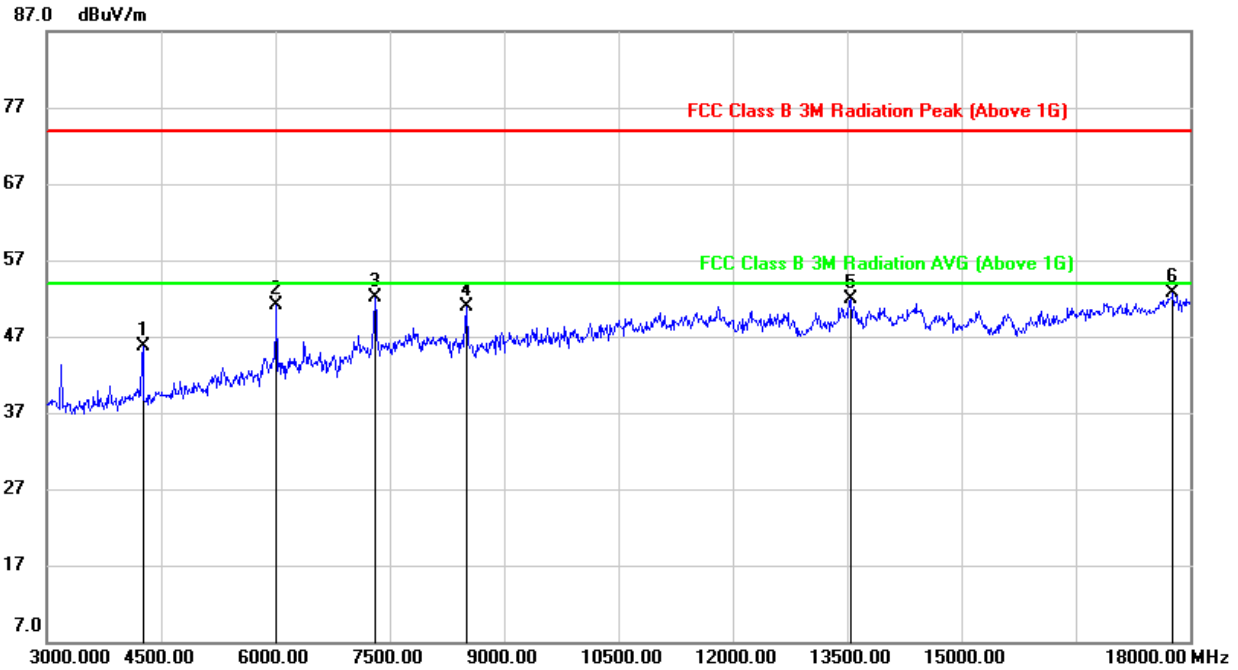

No.	Frequency (MHz)	Reading (dBuV)	Correct (dB/m)	Result (dBuV/m)	Limit (dBuV/m)	Margin (dB)	Remark
1	4260.000	47.46	-1.84	45.62	74.00	-28.38	peak
2	6015.000	47.01	4.01	51.02	74.00	-22.98	peak
3	7305.000	44.72	7.35	52.07	74.00	-21.93	peak
4	8505.000	42.15	8.77	50.92	74.00	-23.08	peak
5	13545.000	35.66	16.24	51.90	74.00	-22.10	peak
6	17775.000	29.56	23.14	52.70	74.00	-21.30	peak

- Note: 1. Measurement = Reading Level + Correct Factor.
 2. If Peak Result complies with AV limit, AV Result is deemed to comply with AV limit.
 3. Peak: Peak detector.
 4. Filter losses were only considered in the spurious frequency bands and the authorized band was not corrected for HPF losses.
 5. Proper operation of the transmitter prior to adding the filter to the measurement chain.



HARMONICS AND SPURIOUS EMISSIONS (HIGH CHANNEL, HORIZONTAL)

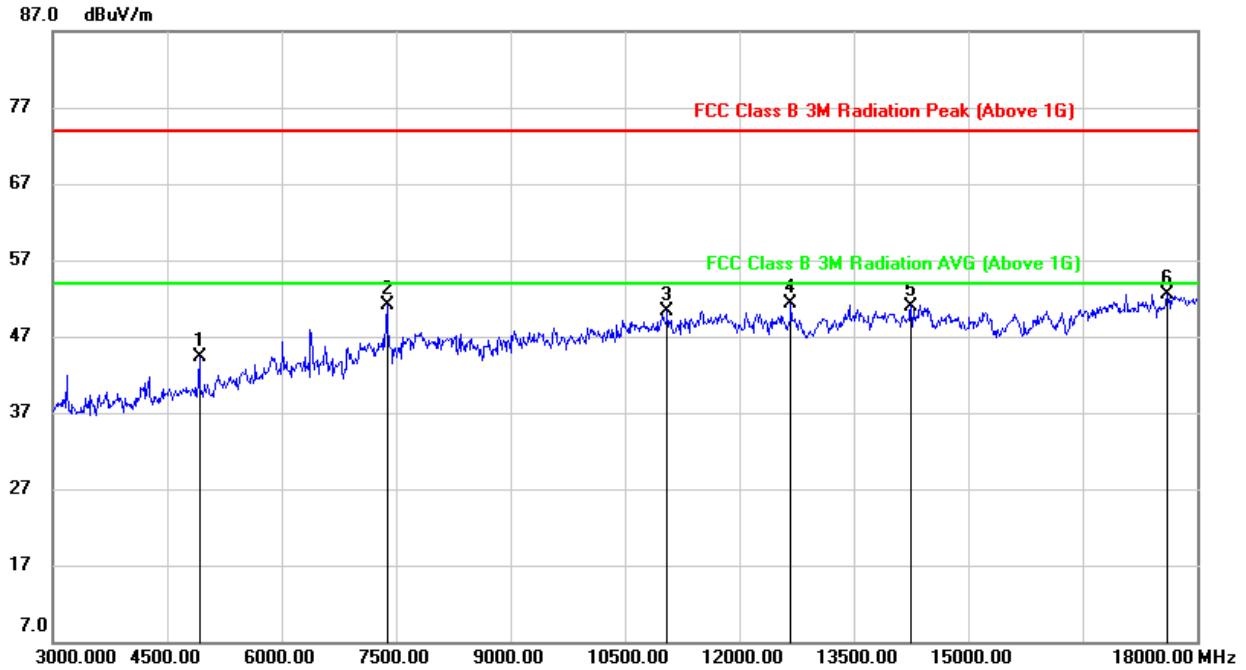

No.	Frequency (MHz)	Reading (dBuV)	Correct (dB/m)	Result (dBuV/m)	Limit (dBuV/m)	Margin (dB)	Remark
1	4920.000	43.97	0.26	44.23	74.00	-29.77	peak
2	7380.000	43.36	7.71	51.07	74.00	-22.93	peak
3	11055.000	36.63	13.61	50.24	74.00	-23.76	peak
4	12675.000	36.66	14.61	51.27	74.00	-22.73	peak
5	14250.000	34.27	16.73	51.00	74.00	-23.00	peak
6	17610.000	30.47	22.00	52.47	74.00	-21.53	peak

- Note: 1. Measurement = Reading Level + Correct Factor.
 2. If Peak Result complies with AV limit, AV Result is deemed to comply with AV limit.
 3. Peak: Peak detector.
 4. Filter losses were only considered in the spurious frequency bands and the authorized band was not corrected for HPF losses.
 5. Proper operation of the transmitter prior to adding the filter to the measurement chain.



HARMONICS AND SPURIOUS EMISSIONS (HIGH CHANNEL, VERTICAL)

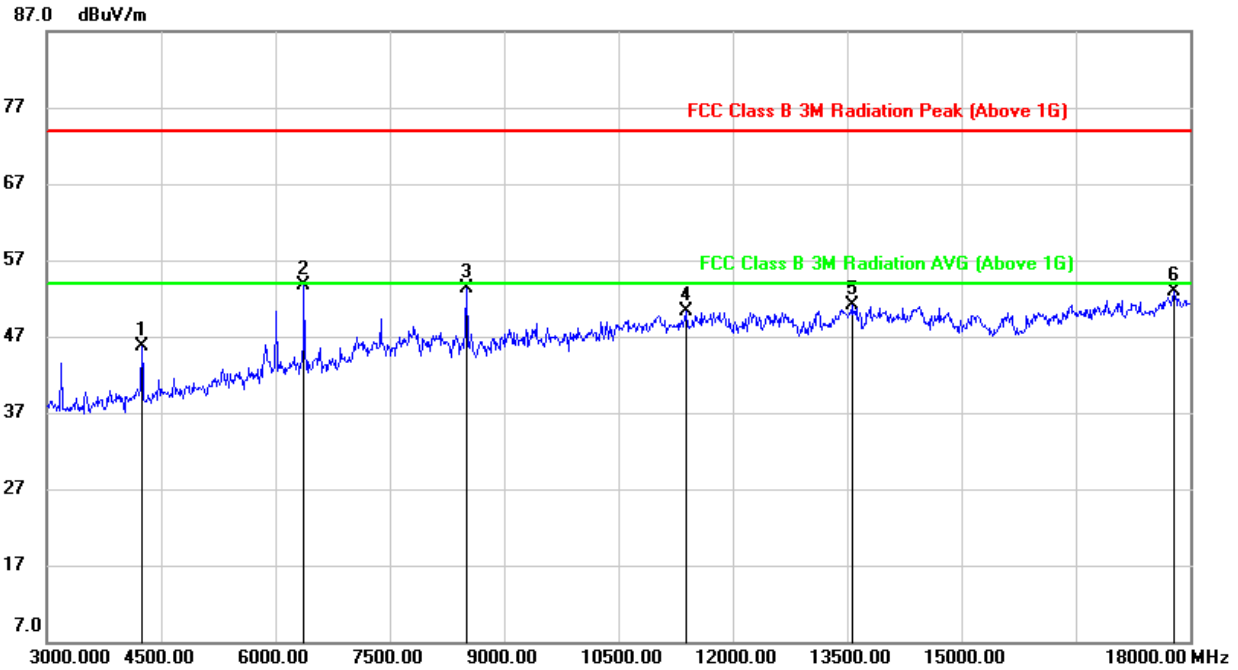

No.	Frequency (MHz)	Reading (dBuV)	Correct (dB/m)	Result (dBuV/m)	Limit (dBuV/m)	Margin (dB)	Remark
1	4245.000	47.43	-1.71	45.72	74.00	-28.28	peak
2	6375.000	48.62	5.08	53.70	74.00	-20.30	peak
3	8505.000	44.51	8.77	53.28	74.00	-20.72	peak
4	11385.000	36.63	13.64	50.27	74.00	-23.73	peak
5	13560.000	34.91	16.29	51.20	74.00	-22.80	peak
6	17790.000	29.59	23.26	52.85	74.00	-21.15	peak

- Note: 1. Measurement = Reading Level + Correct Factor.
 2. If Peak Result complies with AV limit, AV Result is deemed to comply with AV limit.
 3. Peak: Peak detector.
 4. Filter losses were only considered in the spurious frequency bands and the authorized band was not corrected for HPF losses.
 5. Proper operation of the transmitter prior to adding the filter to the measurement chain.



9.2.3. 802.11n HT20 MODE

HARMONICS AND SPURIOUS EMISSIONS (LOW CHANNEL, HORIZONTAL)

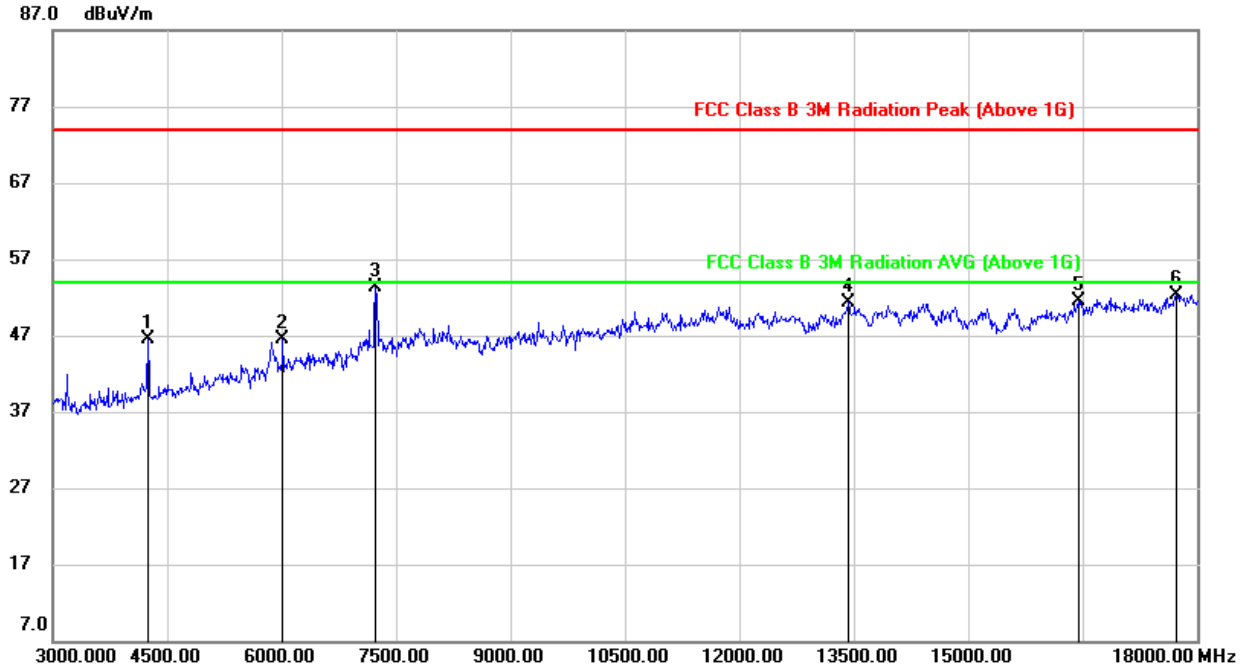

No.	Frequency (MHz)	Reading (dBuV)	Correct (dB/m)	Result (dBuV/m)	Limit (dBuV/m)	Margin (dB)	Remark
1	4245.000	48.27	-1.71	46.56	74.00	-27.44	peak
2	6015.000	42.40	4.01	46.41	74.00	-27.59	peak
3	7230.000	46.20	7.13	53.33	74.00	-20.67	peak
4	13425.000	35.00	16.31	51.31	74.00	-22.69	peak
5	16455.000	32.35	19.16	51.51	74.00	-22.49	peak
6	17730.000	29.55	22.78	52.33	74.00	-21.67	peak

- Note: 1. Measurement = Reading Level + Correct Factor.
 2. If Peak Result complies with AV limit, AV Result is deemed to comply with AV limit.
 3. Peak: Peak detector.
 4. Filter losses were only considered in the spurious frequency bands and the authorized band was not corrected for HPF losses.
 5. Proper operation of the transmitter prior to adding the filter to the measurement chain.



HARMONICS AND SPURIOUS EMISSIONS (LOW CHANNEL, VERTICAL)

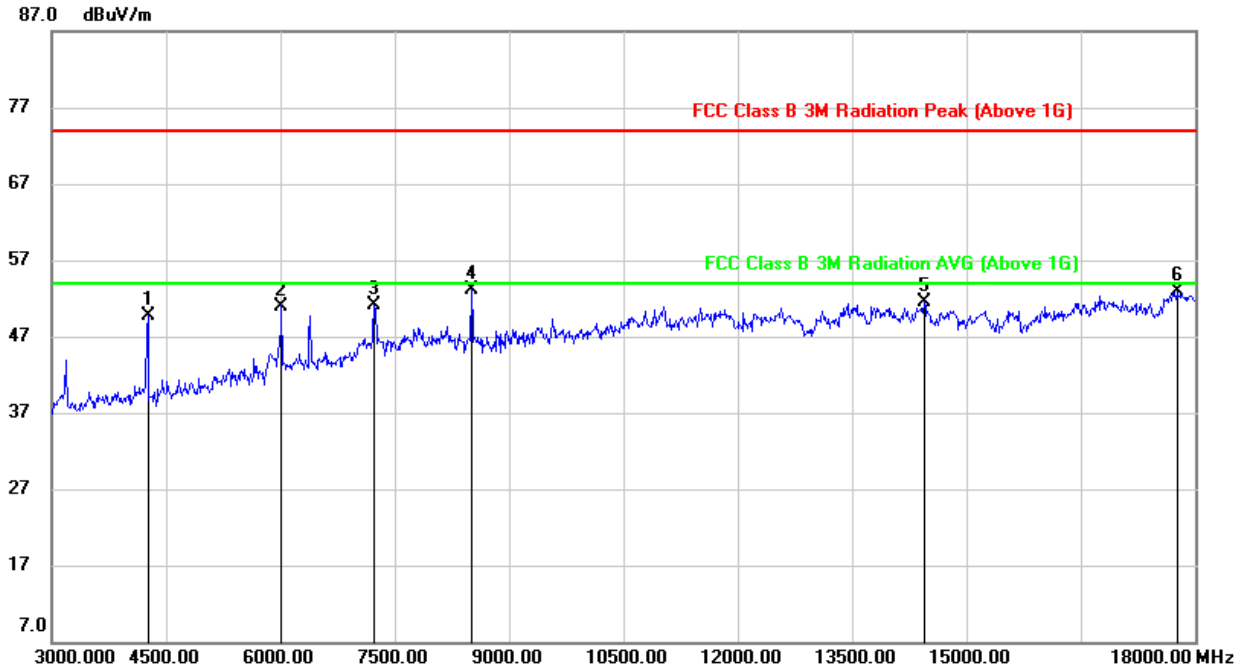

No.	Frequency (MHz)	Reading (dBuV)	Correct (dB/m)	Result (dBuV/m)	Limit (dBuV/m)	Margin (dB)	Remark
1	4260.000	51.56	-1.84	49.72	74.00	-24.28	peak
2	6015.000	46.99	4.01	51.00	74.00	-23.00	peak
3	7230.000	44.03	7.13	51.16	74.00	-22.84	peak
4	8505.000	44.26	8.77	53.03	74.00	-20.97	peak
5	14445.000	34.89	16.66	51.55	74.00	-22.45	peak
6	17760.000	29.84	23.01	52.85	74.00	-21.15	peak

- Note: 1. Measurement = Reading Level + Correct Factor.
 2. If Peak Result complies with AV limit, AV Result is deemed to comply with AV limit.
 3. Peak: Peak detector.
 4. Filter losses were only considered in the spurious frequency bands and the authorized band was not corrected for HPF losses.
 5. Proper operation of the transmitter prior to adding the filter to the measurement chain.



HARMONICS AND SPURIOUS EMISSIONS (MID CHANNEL, HORIZONTAL)

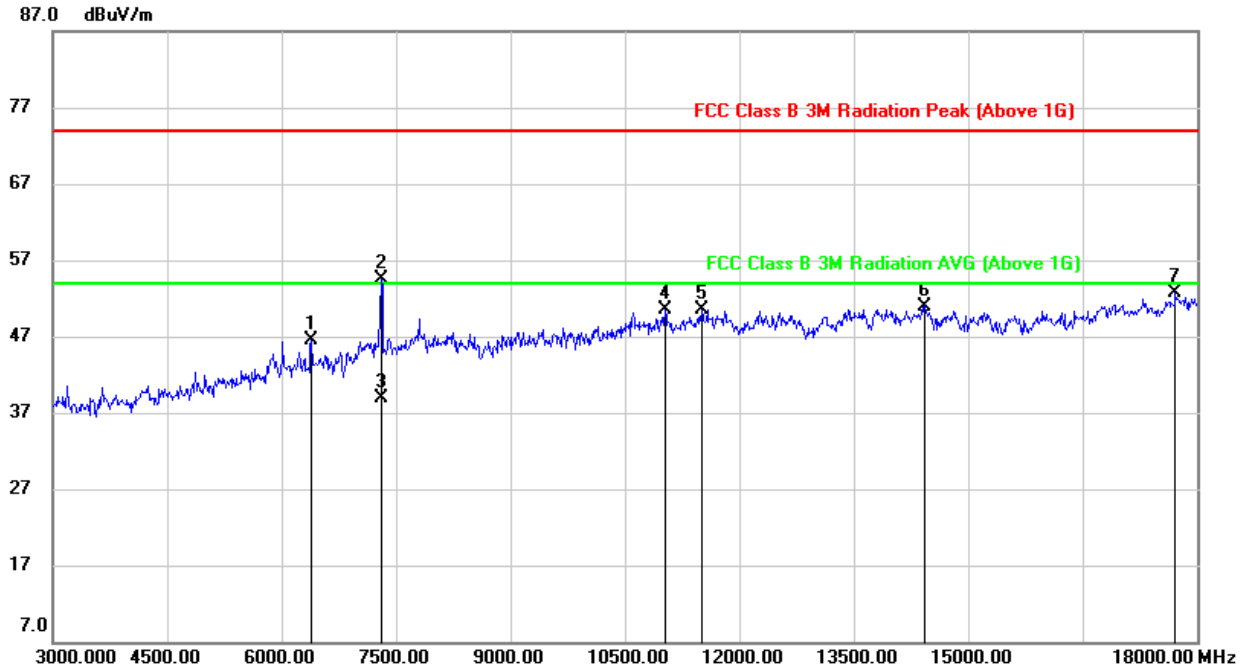

No.	Frequency (MHz)	Reading (dBuV)	Correct (dB/m)	Result (dBuV/m)	Limit (dBuV/m)	Margin (dB)	Remark
1	6390.000	41.26	5.15	46.41	74.00	-27.59	peak
2	7310.644	47.12	7.38	54.50	74.00	-19.50	peak
3	7310.644	31.46	7.38	38.84	54.00	-15.16	AVG
4	11025.000	36.85	13.64	50.49	74.00	-23.51	peak
5	11505.000	36.09	14.50	50.59	74.00	-23.41	peak
6	14430.000	34.34	16.66	51.00	74.00	-23.00	peak
7	17715.000	29.98	22.65	52.63	74.00	-21.37	peak

- Note: 1. Measurement = Reading Level + Correct Factor.
 2. If Peak Result complies with AV limit, AV Result is deemed to comply with AV limit.
 3. Peak: Peak detector.
 4. AVG: $VBW=1/T_{on}$ where: t_{on} is transmit duration.
 5. For transmit duration, please refer to clause 8.1.
 6. Filter losses were only considered in the spurious frequency bands and the authorized band was not corrected for HPF losses.
 7. Proper operation of the transmitter prior to adding the filter to the measurement chain.



HARMONICS AND SPURIOUS EMISSIONS (MID CHANNEL, VERTICAL)

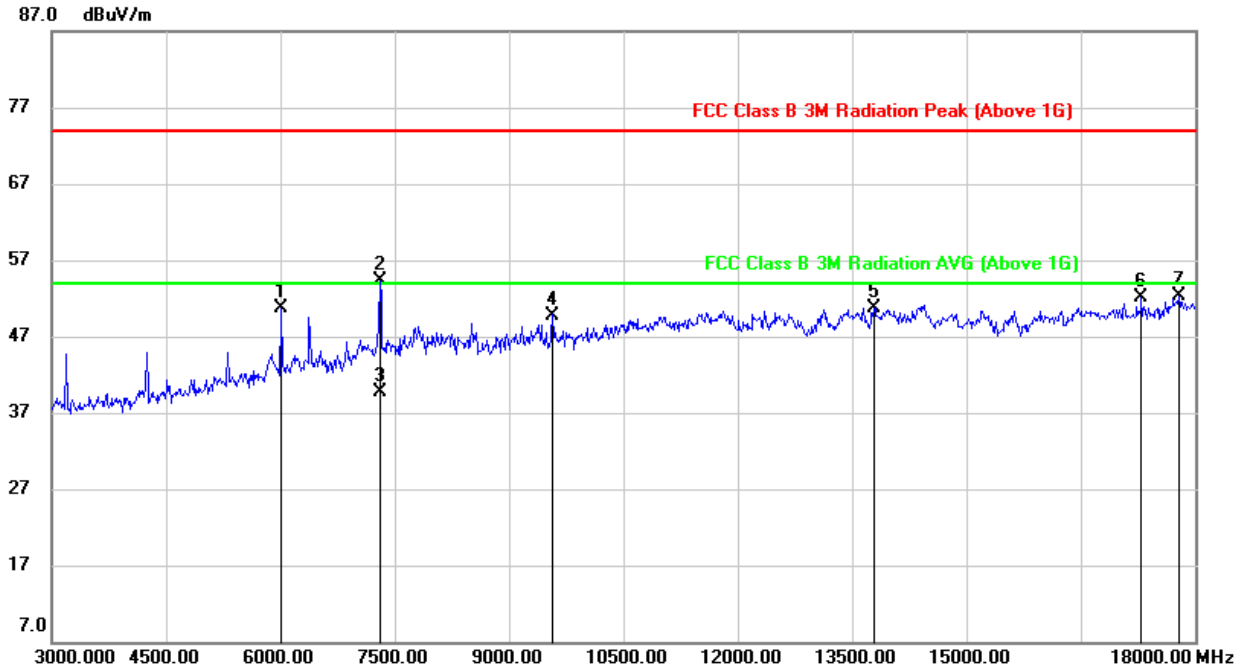

No.	Frequency (MHz)	Reading (dBuV)	Correct (dB/m)	Result (dBuV/m)	Limit (dBuV/m)	Margin (dB)	Remark
1	6015.000	46.64	4.01	50.65	74.00	-23.35	peak
2	7311.394	47.01	7.39	54.40	74.00	-19.60	peak
3	7311.394	32.24	7.39	39.63	54.00	-14.37	AVG
4	9570.000	39.18	10.62	49.80	74.00	-24.20	peak
5	13785.000	33.35	17.40	50.75	74.00	-23.25	peak
6	17295.000	30.04	22.01	52.05	74.00	-21.95	peak
7	17790.000	29.01	23.26	52.27	74.00	-21.73	peak

- Note: 1. Measurement = Reading Level + Correct Factor.
 2. If Peak Result complies with AV limit, AV Result is deemed to comply with AV limit.
 3. Peak: Peak detector.
 4. AVG: VBW=1/Ton where: ton is transmit duration.
 5. For transmit duration, please refer to clause 8.1.
 6. Filter losses were only considered in the spurious frequency bands and the authorized band was not corrected for HPF losses.
 7. Proper operation of the transmitter prior to adding the filter to the measurement chain.



HARMONICS AND SPURIOUS EMISSIONS (HIGH CHANNEL, HORIZONTAL)

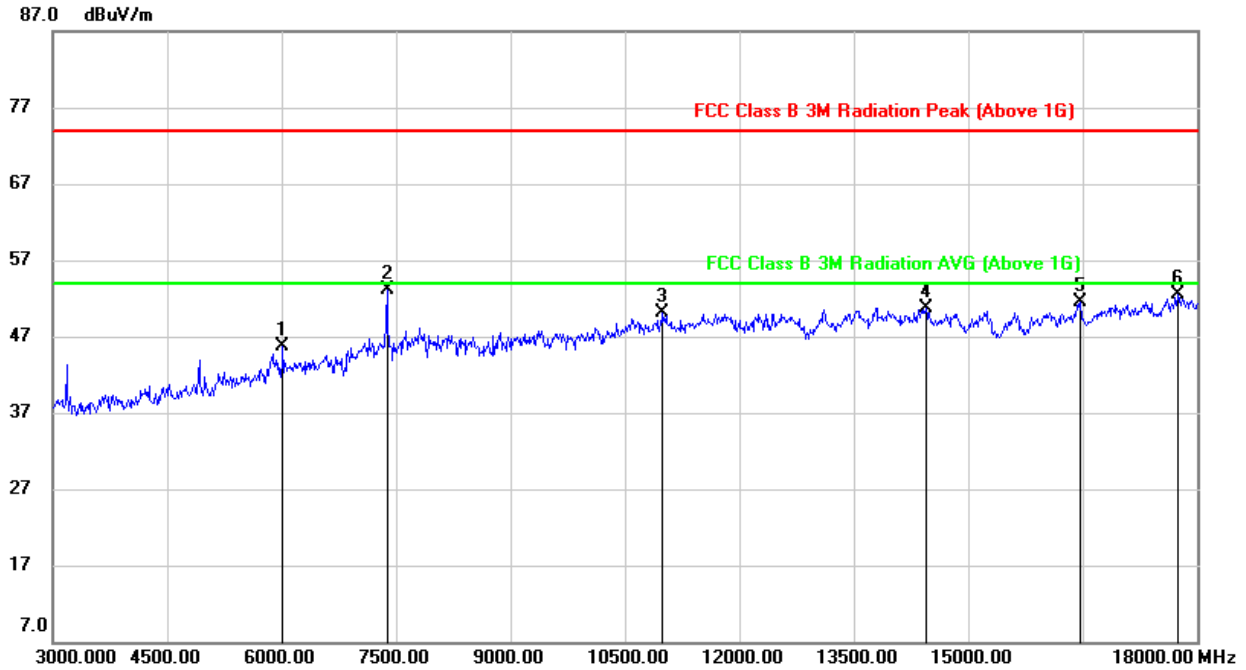

No.	Frequency (MHz)	Reading (dBuV)	Correct (dB/m)	Result (dBuV/m)	Limit (dBuV/m)	Margin (dB)	Remark
1	6015.000	41.72	4.01	45.73	74.00	-28.27	peak
2	7380.000	45.41	7.71	53.12	74.00	-20.88	peak
3	10995.000	36.54	13.62	50.16	74.00	-23.84	peak
4	14445.000	33.98	16.66	50.64	74.00	-23.36	peak
5	16470.000	32.24	19.23	51.47	74.00	-22.53	peak
6	17745.000	29.63	22.89	52.52	74.00	-21.48	peak

- Note: 1. Measurement = Reading Level + Correct Factor.
 2. If Peak Result complies with AV limit, AV Result is deemed to comply with AV limit.
 3. Peak: Peak detector.
 4. Filter losses were only considered in the spurious frequency bands and the authorized band was not corrected for HPF losses.
 5. Proper operation of the transmitter prior to adding the filter to the measurement chain.



HARMONICS AND SPURIOUS EMISSIONS (HIGH CHANNEL, VERTICAL)

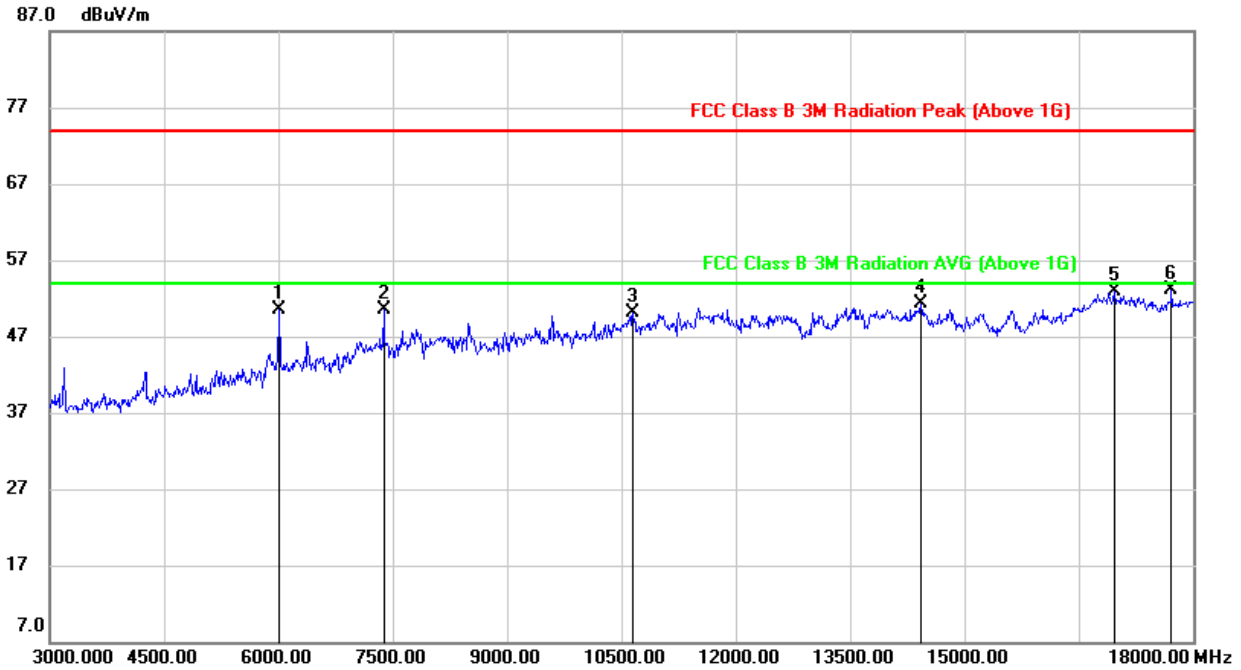

No.	Frequency (MHz)	Reading (dBuV)	Correct (dB/m)	Result (dBuV/m)	Limit (dBuV/m)	Margin (dB)	Remark
1	6015.000	46.58	4.01	50.59	74.00	-23.41	peak
2	7380.000	42.81	7.71	50.52	74.00	-23.48	peak
3	10650.000	37.35	12.76	50.11	74.00	-23.89	peak
4	14430.000	34.72	16.66	51.38	74.00	-22.62	peak
5	16965.000	32.23	20.68	52.91	74.00	-21.09	peak
6	17715.000	30.51	22.65	53.16	74.00	-20.84	peak

- Note: 1. Measurement = Reading Level + Correct Factor.
 2. If Peak Result complies with AV limit, AV Result is deemed to comply with AV limit.
 3. Peak: Peak detector.
 4. Filter losses were only considered in the spurious frequency bands and the authorized band was not corrected for HPF losses.
 5. Proper operation of the transmitter prior to adding the filter to the measurement chain.



9.3. SPURIOUS EMISSIONS (1~3GHz)

9.3.1. 802.11b MODE

HARMONICS AND SPURIOUS EMISSIONS (LOW CHANNEL, HORIZONTAL)

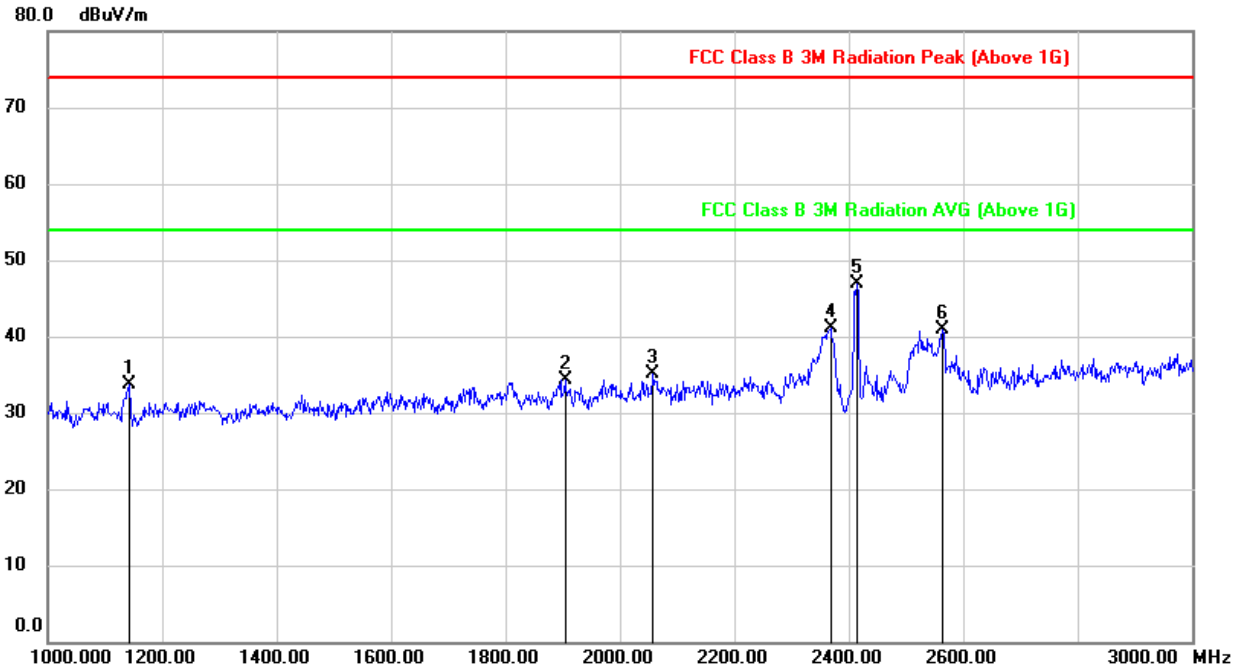

No.	Frequency (MHz)	Reading (dBuV)	Correct (dB/m)	Result (dBuV/m)	Limit (dBuV/m)	Margin (dB)	Remark
1	1142.000	47.18	-13.40	33.78	74.00	-40.22	peak
2	1904.000	44.37	-10.13	34.24	74.00	-39.76	peak
3	2058.000	44.77	-9.61	35.16	74.00	-38.84	peak
4	2368.000	49.21	-8.07	41.14	74.00	-32.86	peak
5	2414.000	54.69	-7.86	46.83	74.00	-27.17	peak
6	2564.000	48.44	-7.58	40.86	74.00	-33.14	peak

- Note: 1. Measurement = Reading Level + Correct Factor.
 2. If Peak Result complies with AV limit, AV Result is deemed to comply with AV limit.
 3. Peak: Peak detector.
 4. Filter losses were only considered in then spurious frequency bands and the authorized band was not corrected for BRF losses.
 5. Proper operation of the transmitter prior to adding the filter to the measurement chain.



HARMONICS AND SPURIOUS EMISSIONS (LOW CHANNEL, VERTICAL)

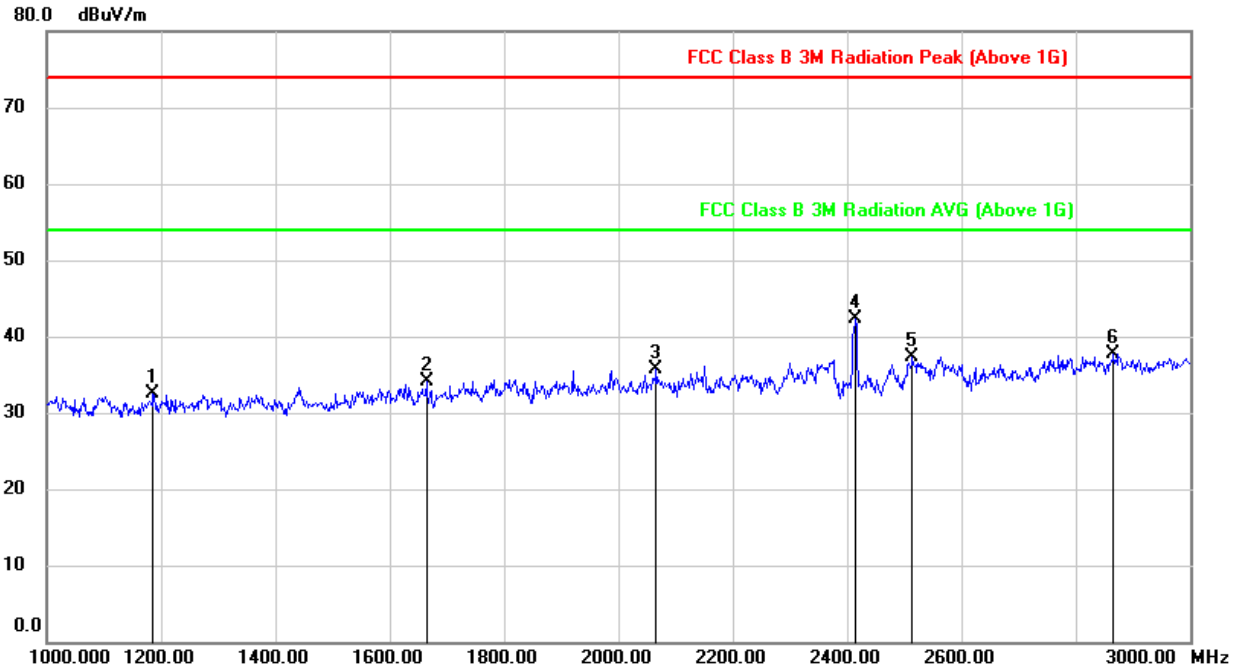

No.	Frequency (MHz)	Reading (dBuV)	Correct (dB/m)	Result (dBuV/m)	Limit (dBuV/m)	Margin (dB)	Remark
1	1186.000	45.58	-13.05	32.53	74.00	-41.47	peak
2	1664.000	45.40	-11.30	34.10	74.00	-39.90	peak
3	2066.000	45.25	-9.55	35.70	74.00	-38.30	peak
4	2414.000	50.17	-7.86	42.31	74.00	-31.69	peak
5	2514.000	44.62	-7.31	37.31	74.00	-36.69	peak
6	2866.000	43.46	-5.71	37.75	74.00	-36.25	peak

- Note: 1. Measurement = Reading Level + Correct Factor.
 2. If Peak Result complies with AV limit, AV Result is deemed to comply with AV limit.
 3. Peak: Peak detector.
 4. Filter losses were only considered in then spurious frequency bands and the authorized band was not corrected for BRF losses.
 5. Proper operation of the transmitter prior to adding the filter to the measurement chain.



HARMONICS AND SPURIOUS EMISSIONS (MID CHANNEL, HORIZONTAL)

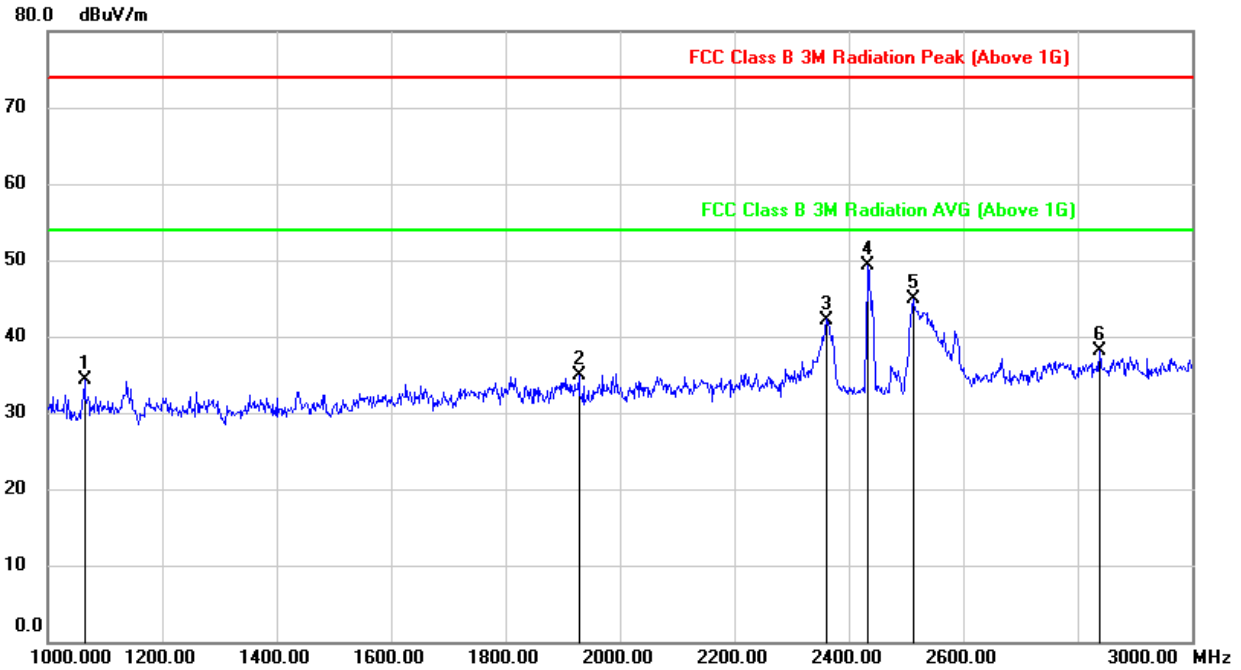

No.	Frequency (MHz)	Reading (dBuV)	Correct (dB/m)	Result (dBuV/m)	Limit (dBuV/m)	Margin (dB)	Remark
1	1064.000	48.09	-13.80	34.29	74.00	-39.71	peak
2	1928.000	45.07	-10.09	34.98	74.00	-39.02	peak
3	2360.000	50.30	-8.10	42.20	74.00	-31.80	peak
4	2434.000	56.97	-7.71	49.26	74.00	-24.74	peak
5	2512.000	52.15	-7.31	44.84	74.00	-29.16	peak
6	2838.000	43.87	-5.86	38.01	74.00	-35.99	peak

- Note: 1. Measurement = Reading Level + Correct Factor.
 2. If Peak Result complies with AV limit, AV Result is deemed to comply with AV limit.
 3. Peak: Peak detector.
 4. Filter losses were only considered in then spurious frequency bands and the authorized band was not corrected for BRF losses.
 5. Proper operation of the transmitter prior to adding the filter to the measurement chain.



HARMONICS AND SPURIOUS EMISSIONS (MID CHANNEL, VERTICAL)

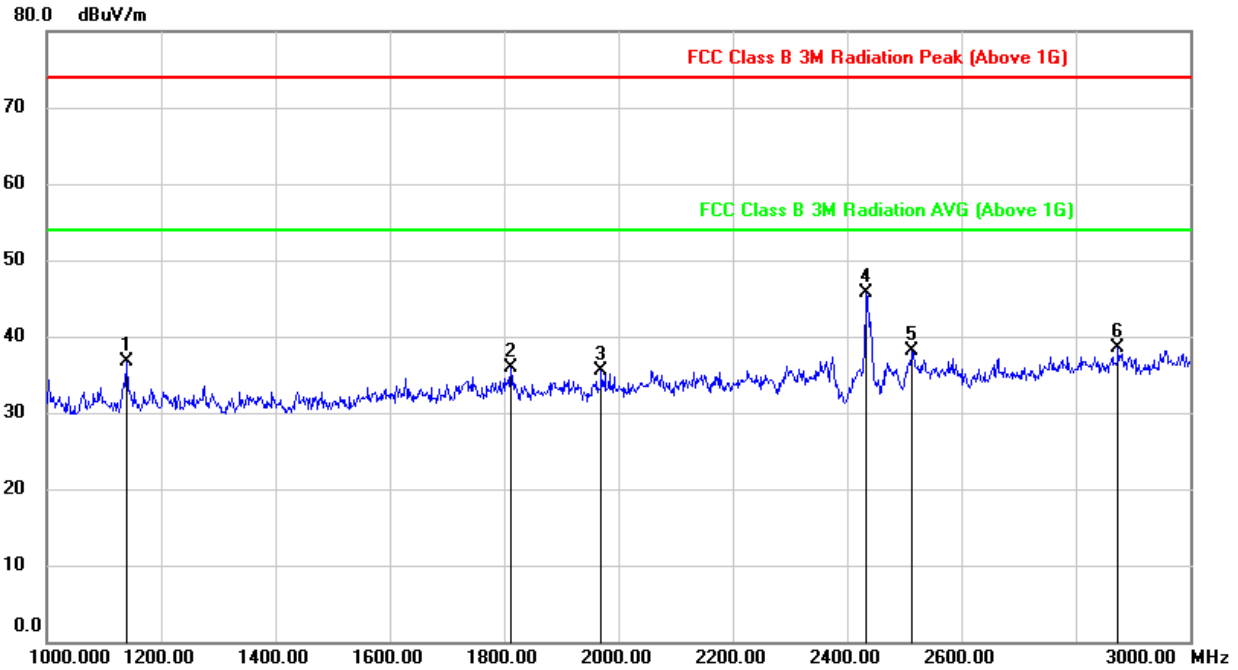

No.	Frequency (MHz)	Reading (dBuV)	Correct (dB/m)	Result (dBuV/m)	Limit (dBuV/m)	Margin (dB)	Remark
1	1140.000	50.08	-13.43	36.65	74.00	-37.35	peak
2	1812.000	46.00	-10.11	35.89	74.00	-38.11	peak
3	1970.000	45.49	-10.04	35.45	74.00	-38.55	peak
4	2434.000	53.50	-7.71	45.79	74.00	-28.21	peak
5	2514.000	45.46	-7.31	38.15	74.00	-35.85	peak
6	2874.000	44.25	-5.66	38.59	74.00	-35.41	peak

- Note: 1. Measurement = Reading Level + Correct Factor.
 2. If Peak Result complies with AV limit, AV Result is deemed to comply with AV limit.
 3. Peak: Peak detector.
 4. Filter losses were only considered in then spurious frequency bands and the authorized band was not corrected for BRF losses.
 5. Proper operation of the transmitter prior to adding the filter to the measurement chain.



HARMONICS AND SPURIOUS EMISSIONS (HIGH CHANNEL, HORIZONTAL)

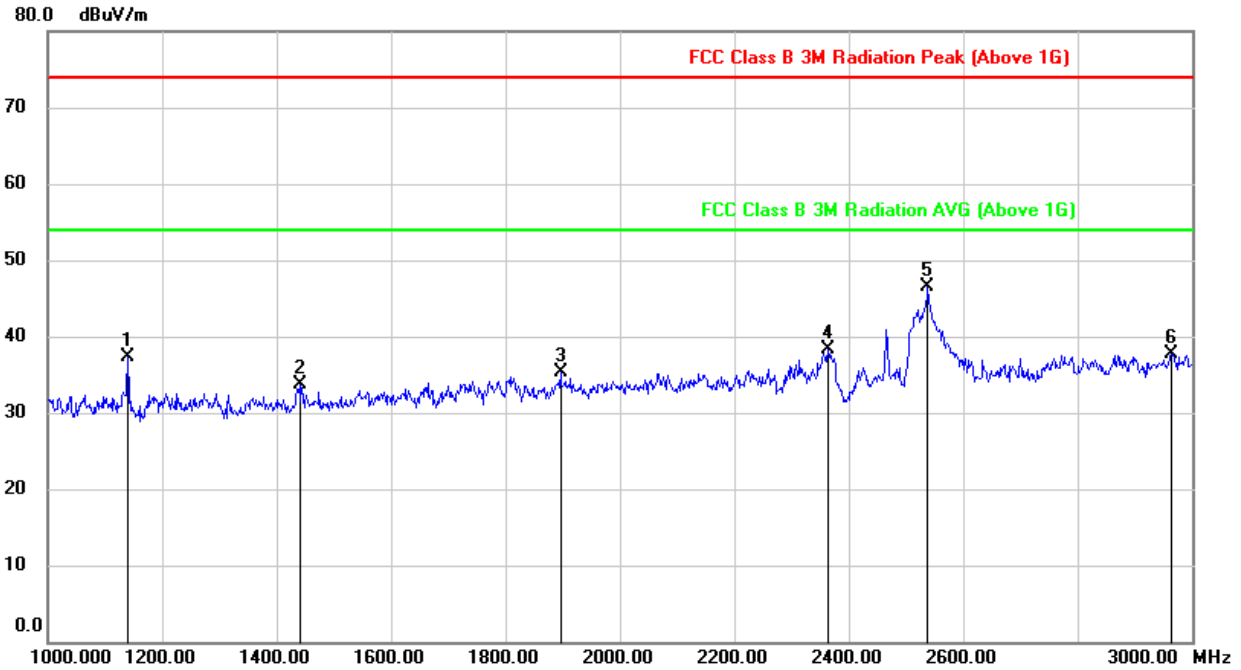

No.	Frequency (MHz)	Reading (dBuV)	Correct (dB/m)	Result (dBuV/m)	Limit (dBuV/m)	Margin (dB)	Remark
1	1140.000	50.69	-13.43	37.26	74.00	-36.74	peak
2	1440.000	46.20	-12.54	33.66	74.00	-40.34	peak
3	1896.000	45.36	-10.14	35.22	74.00	-38.78	peak
4	2364.000	46.34	-8.08	38.26	74.00	-35.74	peak
5	2538.000	53.89	-7.44	46.45	74.00	-27.55	peak
6	2964.000	43.05	-5.37	37.68	74.00	-36.32	peak

- Note: 1. Measurement = Reading Level + Correct Factor.
 2. If Peak Result complies with AV limit, AV Result is deemed to comply with AV limit.
 3. Peak: Peak detector.
 4. Filter losses were only considered in then spurious frequency bands and the authorized band was not corrected for BRF losses.
 5. Proper operation of the transmitter prior to adding the filter to the measurement chain.



HARMONICS AND SPURIOUS EMISSIONS (HIGH CHANNEL, VERTICAL)

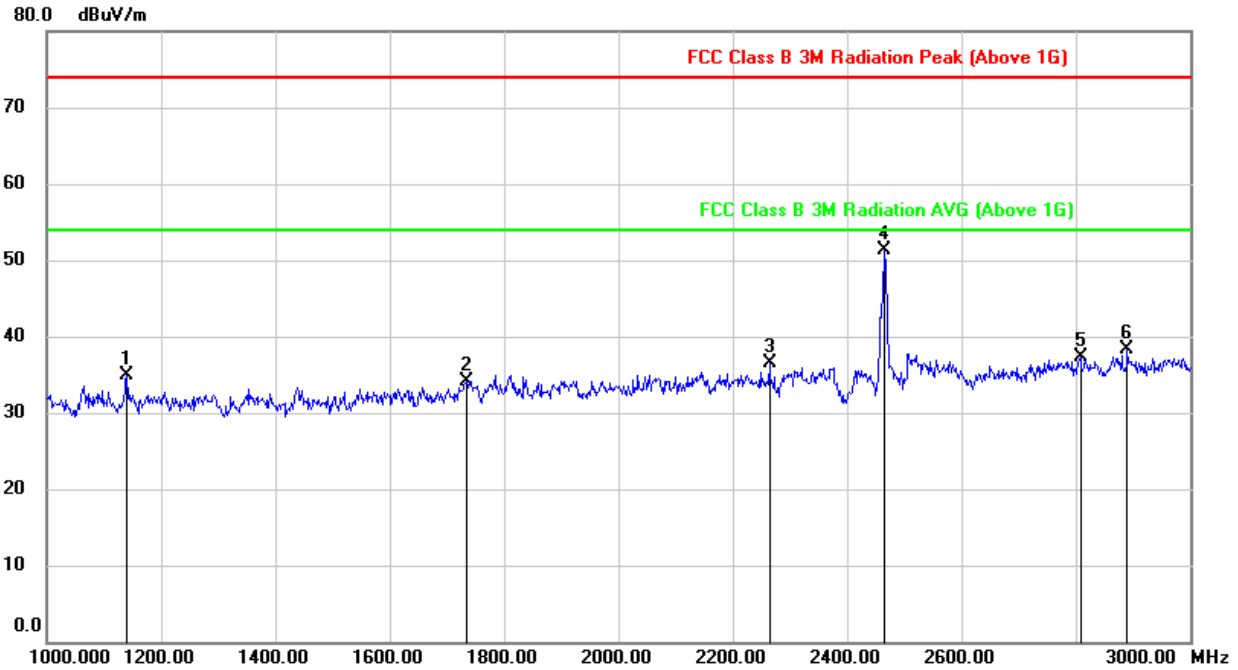

No.	Frequency (MHz)	Reading (dBuV)	Correct (dB/m)	Result (dBuV/m)	Limit (dBuV/m)	Margin (dB)	Remark
1	1140.000	48.27	-13.43	34.84	74.00	-39.16	peak
2	1734.000	44.84	-10.77	34.07	74.00	-39.93	peak
3	2264.000	44.93	-8.49	36.44	74.00	-37.56	peak
4	2466.000	58.74	-7.49	51.25	74.00	-22.75	peak
5	2808.000	43.25	-6.03	37.22	74.00	-36.78	peak
6	2890.000	43.93	-5.58	38.35	74.00	-35.65	peak

- Note: 1. Measurement = Reading Level + Correct Factor.
 2. If Peak Result complies with AV limit, AV Result is deemed to comply with AV limit.
 3. Peak: Peak detector.
 4. Filter losses were only considered in then spurious frequency bands and the authorized band was not corrected for BRF losses.
 5. Proper operation of the transmitter prior to adding the filter to the measurement chain.



9.3.2. 802.11g MODE

HARMONICS AND SPURIOUS EMISSIONS (LOW CHANNEL, HORIZONTAL)

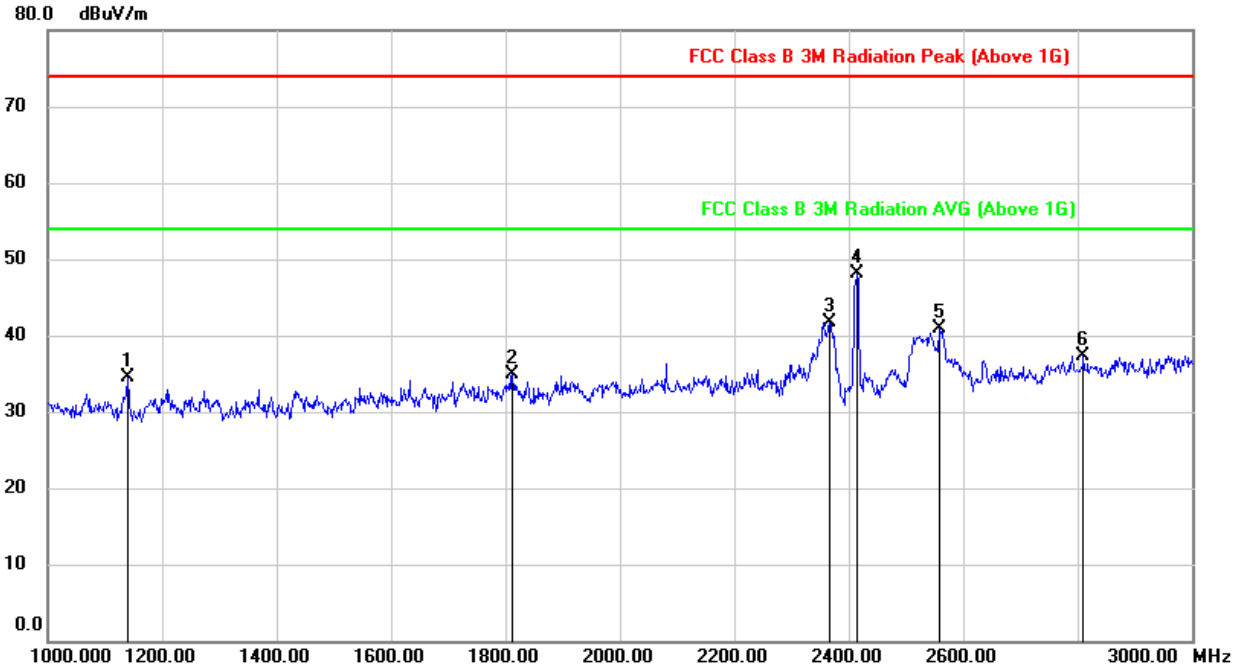

No.	Frequency (MHz)	Reading (dBuV)	Correct (dB/m)	Result (dBuV/m)	Limit (dBuV/m)	Margin (dB)	Remark
1	1140.000	47.87	-13.43	34.44	74.00	-39.56	peak
2	1812.000	45.05	-10.11	34.94	74.00	-39.06	peak
3	2366.000	49.87	-8.07	41.80	74.00	-32.20	peak
4	2414.000	55.94	-7.86	48.08	74.00	-25.92	peak
5	2558.000	48.43	-7.54	40.89	74.00	-33.11	peak
6	2810.000	43.26	-6.02	37.24	74.00	-36.76	peak

- Note:
1. Measurement = Reading Level + Correct Factor.
 2. If Peak Result complies with AV limit, AV Result is deemed to comply with AV limit.
 3. Peak: Peak detector.
 4. Filter losses were only considered in then spurious frequency bands and the authorized band was not corrected for BRF losses.
 5. Proper operation of the transmitter prior to adding the filter to the measurement chain.



HARMONICS AND SPURIOUS EMISSIONS (LOW CHANNEL, VERTICAL)

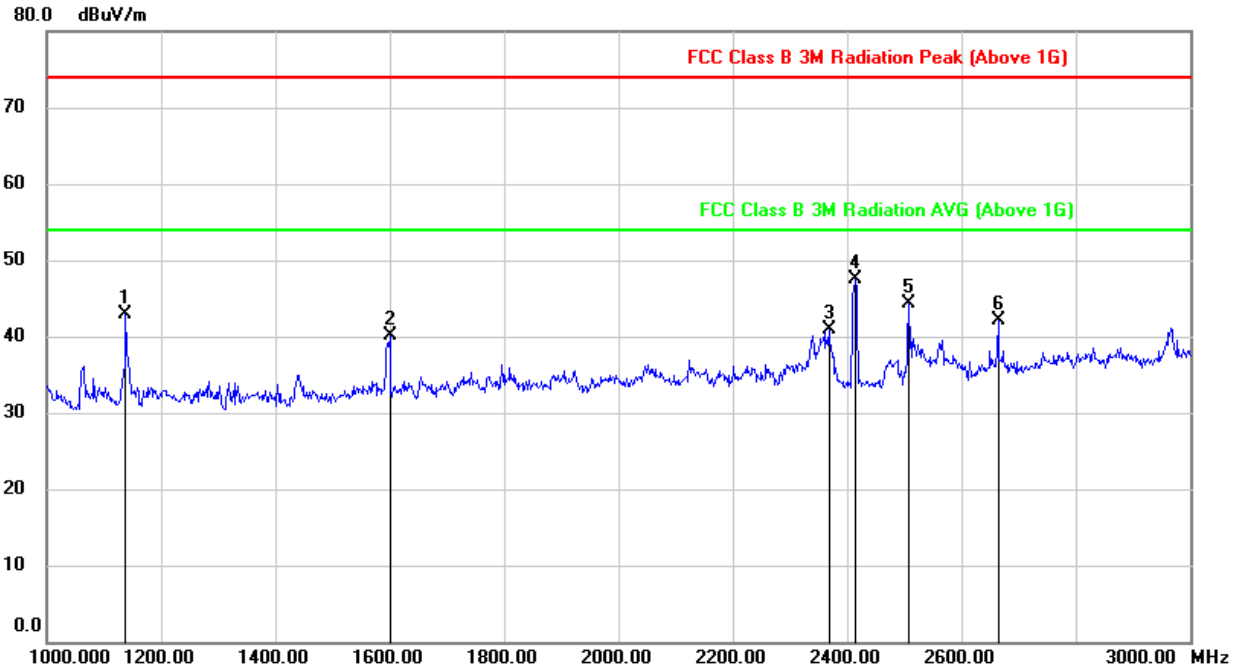

No.	Frequency (MHz)	Reading (dBuV)	Correct (dB/m)	Result (dBuV/m)	Limit (dBuV/m)	Margin (dB)	Remark
1	1138.000	56.42	-13.44	42.98	74.00	-31.02	peak
2	1600.000	51.65	-11.61	40.04	74.00	-33.96	peak
3	2368.000	49.03	-8.07	40.96	74.00	-33.04	peak
4	2414.000	55.35	-7.86	47.49	74.00	-26.51	peak
5	2508.000	51.51	-7.29	44.22	74.00	-29.78	peak
6	2664.000	49.52	-7.39	42.13	74.00	-31.87	peak

- Note: 1. Measurement = Reading Level + Correct Factor.
 2. If Peak Result complies with AV limit, AV Result is deemed to comply with AV limit.
 3. Peak: Peak detector.
 4. Filter losses were only considered in then spurious frequency bands and the authorized band was not corrected for BRF losses.
 5. Proper operation of the transmitter prior to adding the filter to the measurement chain.



HARMONICS AND SPURIOUS EMISSIONS (MID CHANNEL, HORIZONTAL)

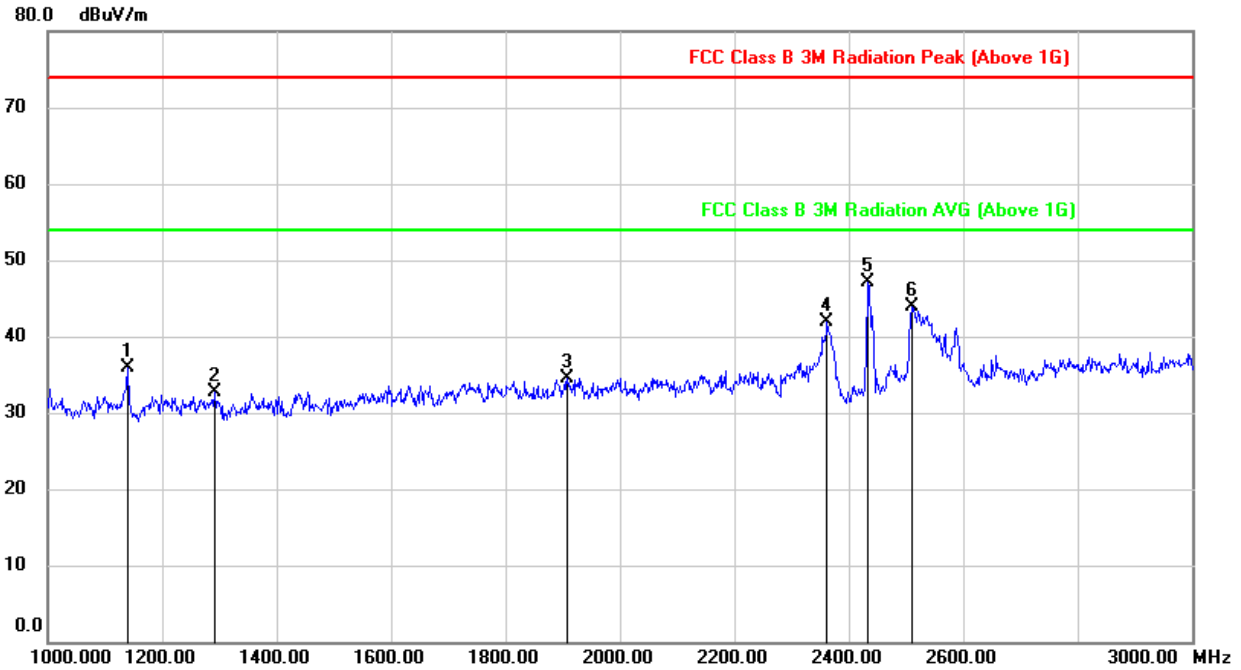

No.	Frequency (MHz)	Reading (dBuV)	Correct (dB/m)	Result (dBuV/m)	Limit (dBuV/m)	Margin (dB)	Remark
1	1140.000	49.38	-13.43	35.95	74.00	-38.05	peak
2	1292.000	45.36	-12.60	32.76	74.00	-41.24	peak
3	1908.000	44.71	-10.13	34.58	74.00	-39.42	peak
4	2362.000	50.04	-8.10	41.94	74.00	-32.06	peak
5	2434.000	54.81	-7.71	47.10	74.00	-26.90	peak
6	2510.000	51.15	-7.29	43.86	74.00	-30.14	peak

- Note: 1. Measurement = Reading Level + Correct Factor.
 2. If Peak Result complies with AV limit, AV Result is deemed to comply with AV limit.
 3. Peak: Peak detector.
 4. Filter losses were only considered in then spurious frequency bands and the authorized band was not corrected for BRF losses.
 5. Proper operation of the transmitter prior to adding the filter to the measurement chain.



HARMONICS AND SPURIOUS EMISSIONS (MID CHANNEL, VERTICAL)

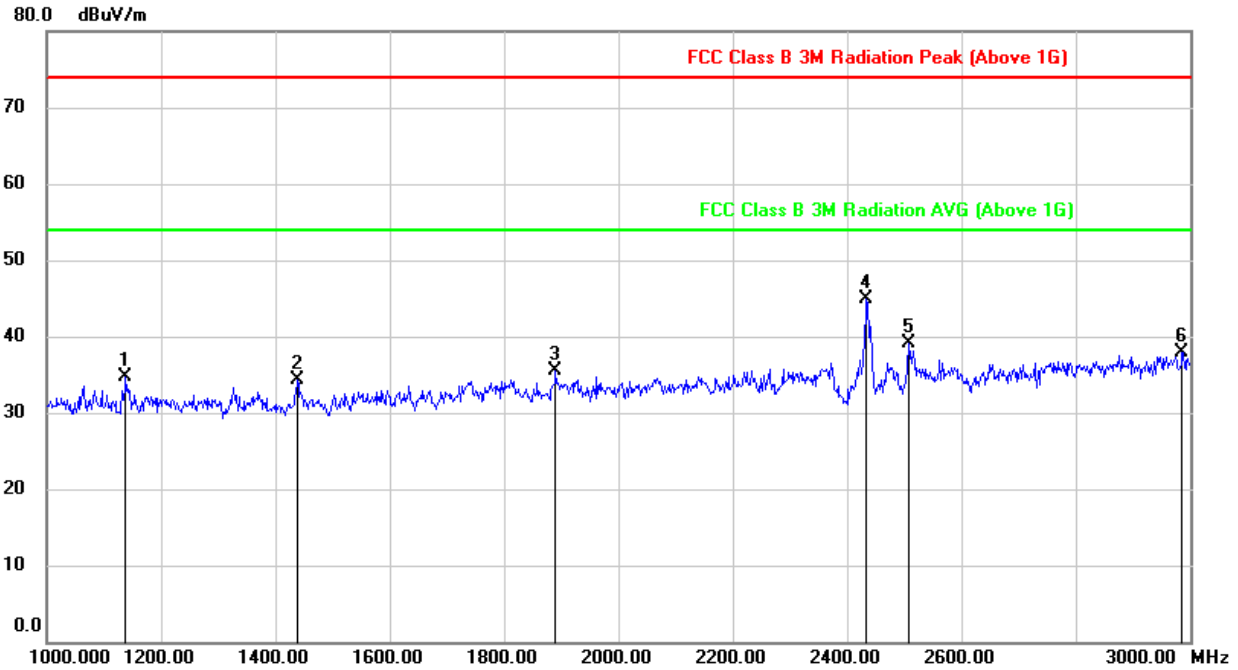

No.	Frequency (MHz)	Reading (dBuV)	Correct (dB/m)	Result (dBuV/m)	Limit (dBuV/m)	Margin (dB)	Remark
1	1138.000	48.22	-13.44	34.78	74.00	-39.22	peak
2	1438.000	46.93	-12.54	34.39	74.00	-39.61	peak
3	1890.000	45.59	-10.14	35.45	74.00	-38.55	peak
4	2434.000	52.55	-7.71	44.84	74.00	-29.16	peak
5	2508.000	46.36	-7.29	39.07	74.00	-34.93	peak
6	2986.000	43.15	-5.31	37.84	74.00	-36.16	peak

- Note: 1. Measurement = Reading Level + Correct Factor.
 2. If Peak Result complies with AV limit, AV Result is deemed to comply with AV limit.
 3. Peak: Peak detector.
 4. Filter losses were only considered in then spurious frequency bands and the authorized band was not corrected for BRF losses.
 5. Proper operation of the transmitter prior to adding the filter to the measurement chain.



HARMONICS AND SPURIOUS EMISSIONS (HIGH CHANNEL, HORIZONTAL)

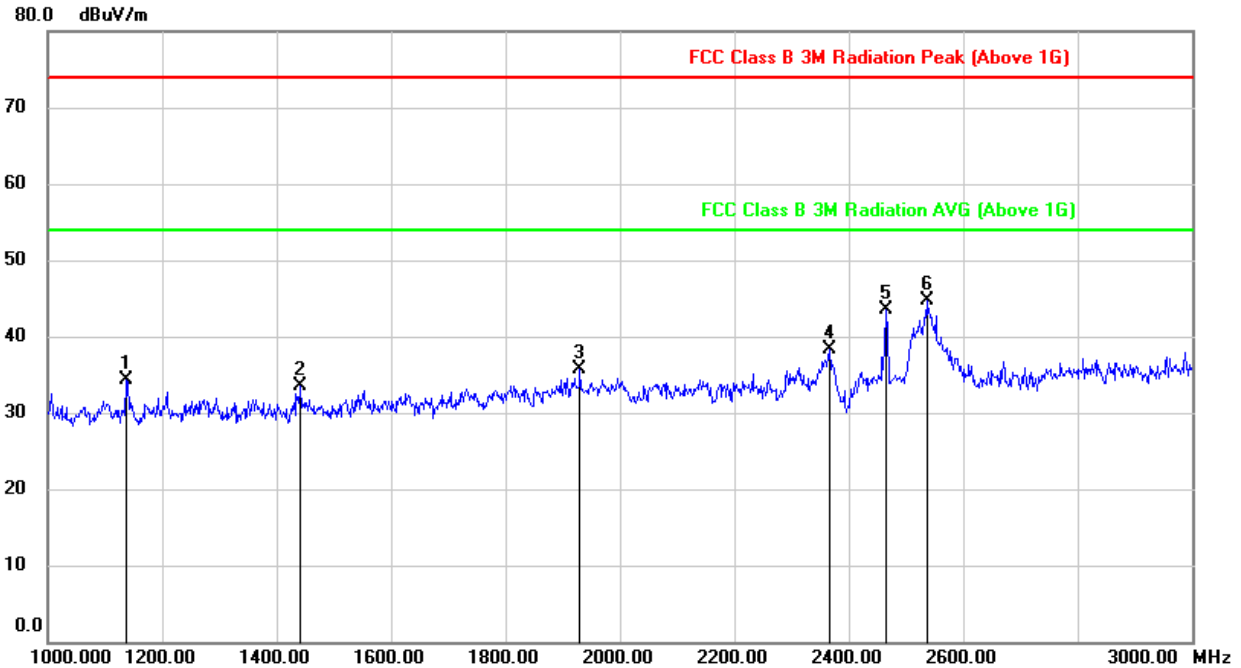

No.	Frequency (MHz)	Reading (dBuV)	Correct (dB/m)	Result (dBuV/m)	Limit (dBuV/m)	Margin (dB)	Remark
1	1136.000	47.85	-13.47	34.38	74.00	-39.62	peak
2	1442.000	46.02	-12.53	33.49	74.00	-40.51	peak
3	1930.000	45.74	-10.10	35.64	74.00	-38.36	peak
4	2366.000	46.42	-8.07	38.35	74.00	-35.65	peak
5	2464.000	50.92	-7.50	43.42	74.00	-30.58	peak
6	2536.000	52.06	-7.43	44.63	74.00	-29.37	peak

- Note: 1. Measurement = Reading Level + Correct Factor.
 2. If Peak Result complies with AV limit, AV Result is deemed to comply with AV limit.
 3. Peak: Peak detector.
 4. Filter losses were only considered in then spurious frequency bands and the authorized band was not corrected for BRF losses.
 5. Proper operation of the transmitter prior to adding the filter to the measurement chain.



HARMONICS AND SPURIOUS EMISSIONS (HIGH CHANNEL, VERTICAL)

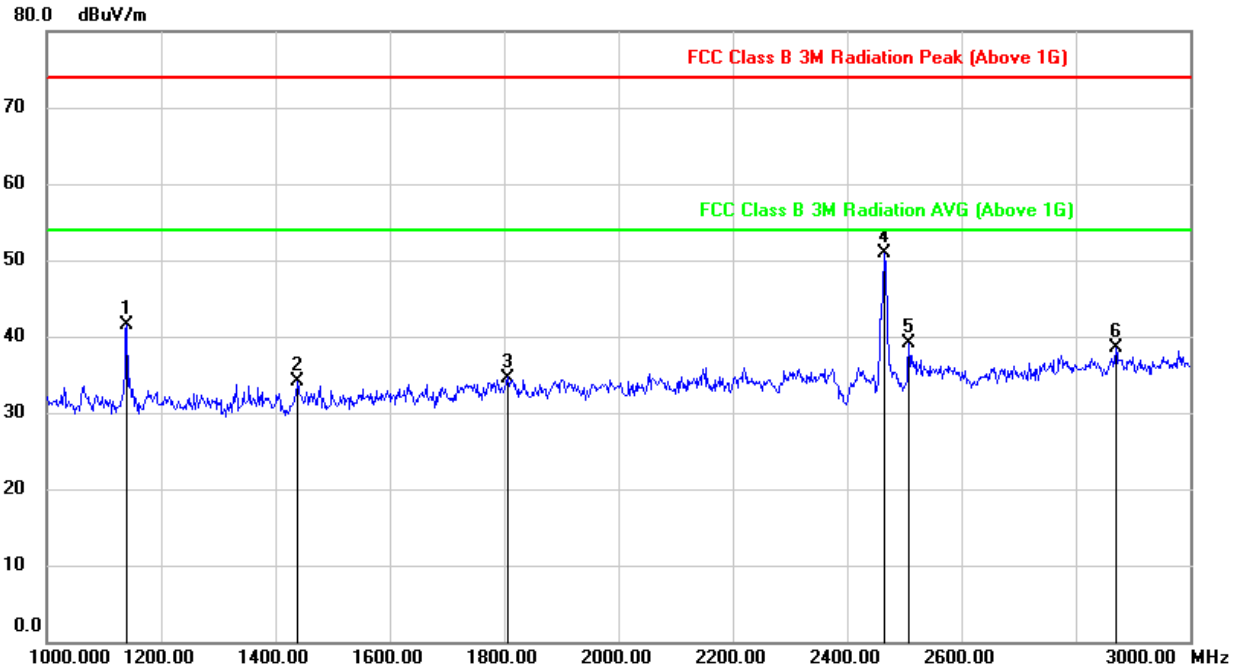

No.	Frequency (MHz)	Reading (dBuV)	Correct (dB/m)	Result (dBuV/m)	Limit (dBuV/m)	Margin (dB)	Remark
1	1140.000	54.89	-13.43	41.46	74.00	-32.54	peak
2	1438.000	46.74	-12.54	34.20	74.00	-39.80	peak
3	1806.000	44.71	-10.11	34.60	74.00	-39.40	peak
4	2466.000	58.46	-7.49	50.97	74.00	-23.03	peak
5	2508.000	46.38	-7.29	39.09	74.00	-34.91	peak
6	2870.000	44.23	-5.69	38.54	74.00	-35.46	peak

- Note: 1. Measurement = Reading Level + Correct Factor.
 2. If Peak Result complies with AV limit, AV Result is deemed to comply with AV limit.
 3. Peak: Peak detector.
 4. Filter losses were only considered in then spurious frequency bands and the authorized band was not corrected for BRF losses.
 5. Proper operation of the transmitter prior to adding the filter to the measurement chain.



9.3.3. 802.11n HT20 MODE

HARMONICS AND SPURIOUS EMISSIONS (LOW CHANNEL, HORIZONTAL)

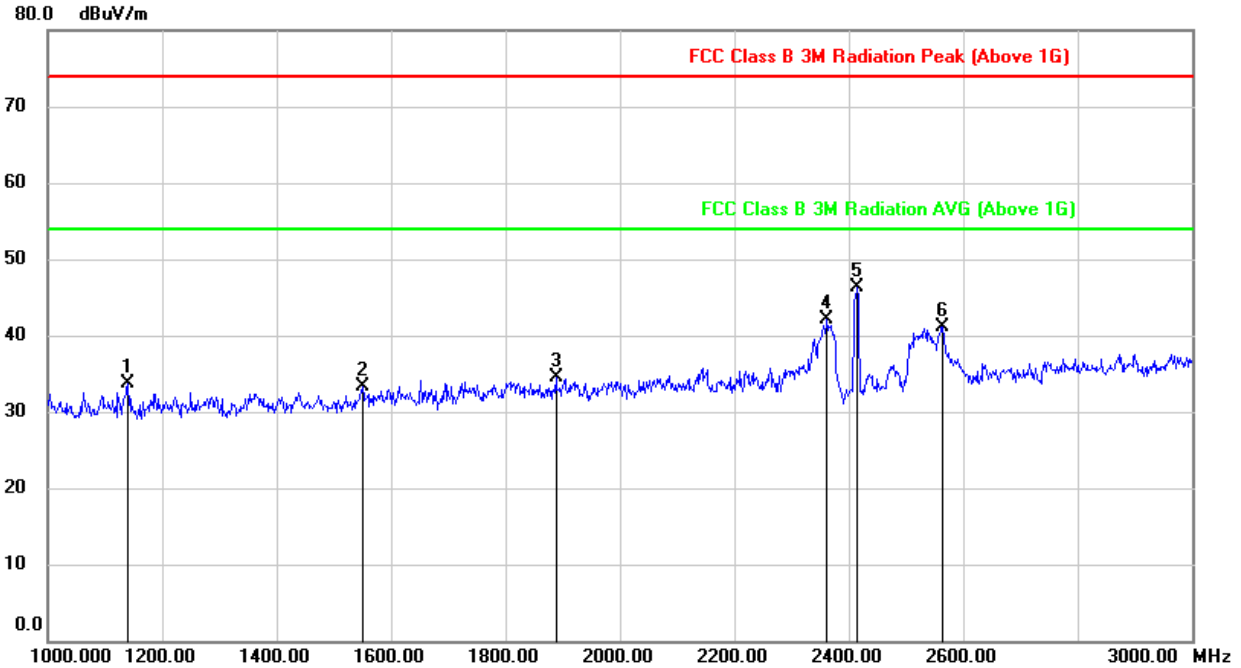

No.	Frequency (MHz)	Reading (dBuV)	Correct (dB/m)	Result (dBuV/m)	Limit (dBuV/m)	Margin (dB)	Remark
1	1140.000	47.08	-13.43	33.65	74.00	-40.35	peak
2	1550.000	45.25	-12.02	33.23	74.00	-40.77	peak
3	1888.000	44.65	-10.14	34.51	74.00	-39.49	peak
4	2362.000	50.23	-8.10	42.13	74.00	-31.87	peak
5	2414.000	54.07	-7.86	46.21	74.00	-27.79	peak
6	2564.000	48.77	-7.58	41.19	74.00	-32.81	peak

- Note: 1. Measurement = Reading Level + Correct Factor.
 2. If Peak Result complies with AV limit, AV Result is deemed to comply with AV limit.
 3. Peak: Peak detector.
 4. Filter losses were only considered in then spurious frequency bands and the authorized band was not corrected for BRF losses.
 5. Proper operation of the transmitter prior to adding the filter to the measurement chain.



HARMONICS AND SPURIOUS EMISSIONS (LOW CHANNEL, VERTICAL)

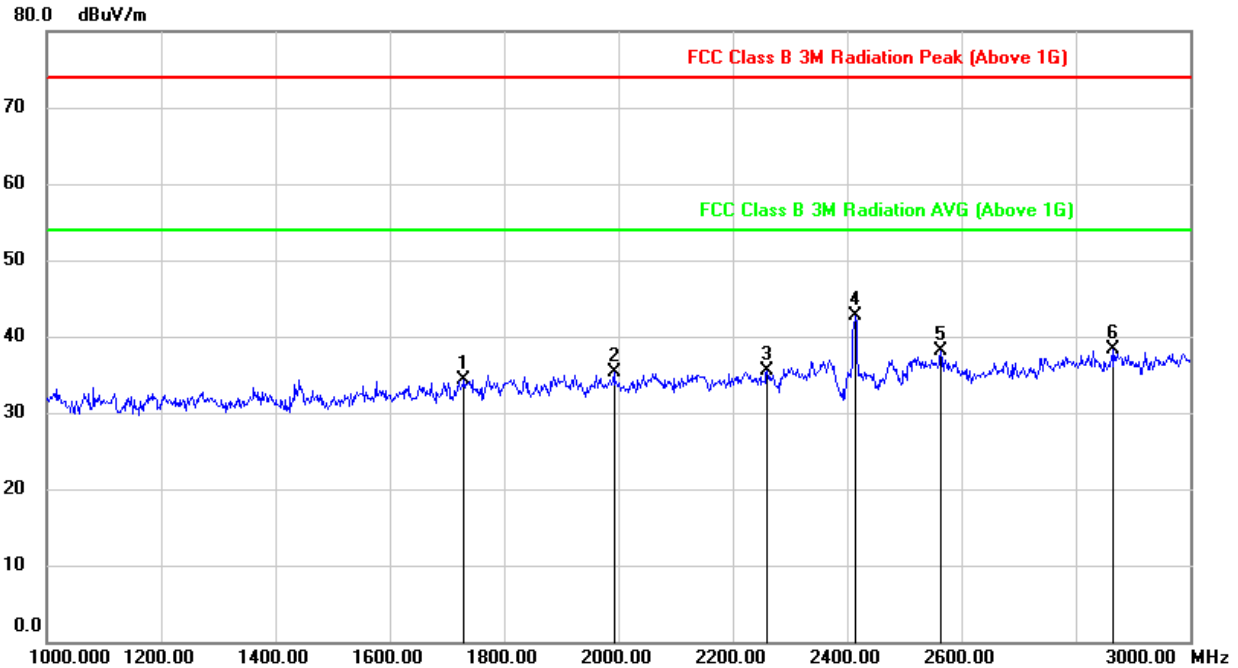

No.	Frequency (MHz)	Reading (dBuV)	Correct (dB/m)	Result (dBuV/m)	Limit (dBuV/m)	Margin (dB)	Remark
1	1730.000	45.20	-10.81	34.39	74.00	-39.61	peak
2	1992.000	45.31	-10.01	35.30	74.00	-38.70	peak
3	2260.000	43.96	-8.51	35.45	74.00	-38.55	peak
4	2414.000	50.65	-7.86	42.79	74.00	-31.21	peak
5	2564.000	45.61	-7.58	38.03	74.00	-35.97	peak
6	2866.000	43.94	-5.71	38.23	74.00	-35.77	peak

- Note: 1. Measurement = Reading Level + Correct Factor.
 2. If Peak Result complies with AV limit, AV Result is deemed to comply with AV limit.
 3. Peak: Peak detector.
 4. Filter losses were only considered in then spurious frequency bands and the authorized band was not corrected for BRF losses.
 5. Proper operation of the transmitter prior to adding the filter to the measurement chain.



HARMONICS AND SPURIOUS EMISSIONS (MID CHANNEL, HORIZONTAL)

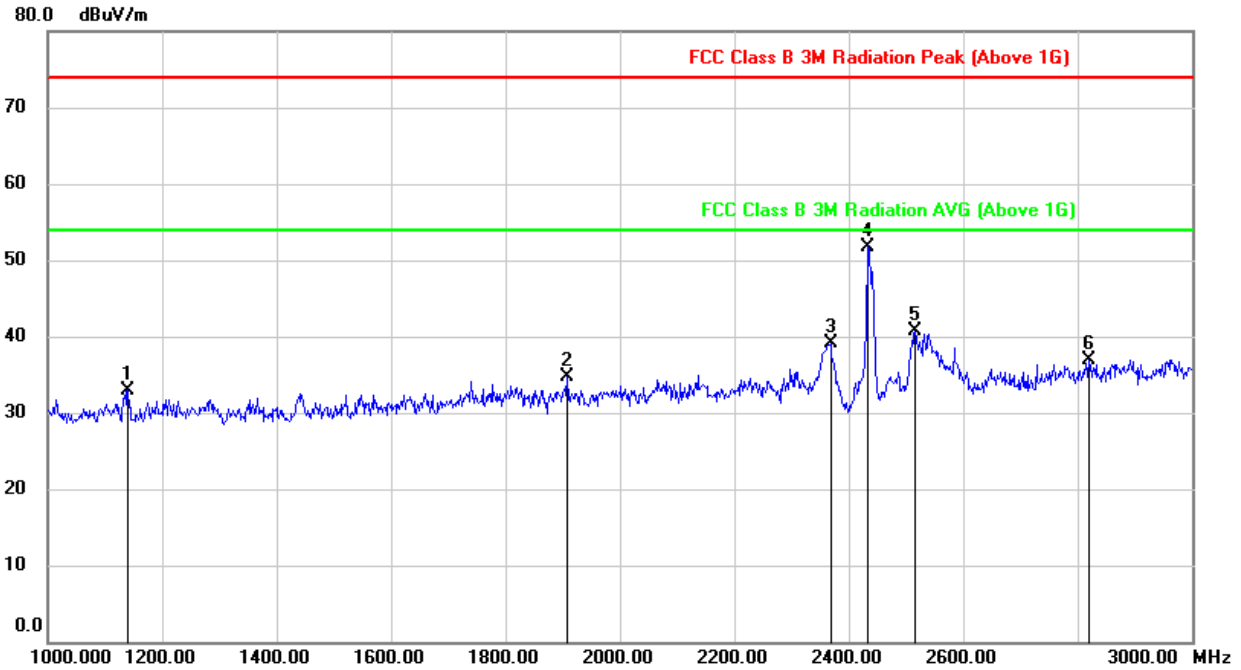

No.	Frequency (MHz)	Reading (dBuV)	Correct (dB/m)	Result (dBuV/m)	Limit (dBuV/m)	Margin (dB)	Remark
1	1140.000	46.41	-13.43	32.98	74.00	-41.02	peak
2	1908.000	44.91	-10.13	34.78	74.00	-39.22	peak
3	2368.000	47.16	-8.07	39.09	74.00	-34.91	peak
4	2434.000	59.51	-7.71	51.80	74.00	-22.20	peak
5	2516.000	48.05	-7.32	40.73	74.00	-33.27	peak
6	2820.000	42.94	-5.97	36.97	74.00	-37.03	peak

- Note: 1. Measurement = Reading Level + Correct Factor.
 2. If Peak Result complies with AV limit, AV Result is deemed to comply with AV limit.
 3. Peak: Peak detector.
 4. Filter losses were only considered in then spurious frequency bands and the authorized band was not corrected for BRF losses.
 5. Proper operation of the transmitter prior to adding the filter to the measurement chain.



HARMONICS AND SPURIOUS EMISSIONS (MID CHANNEL, VERTICAL)

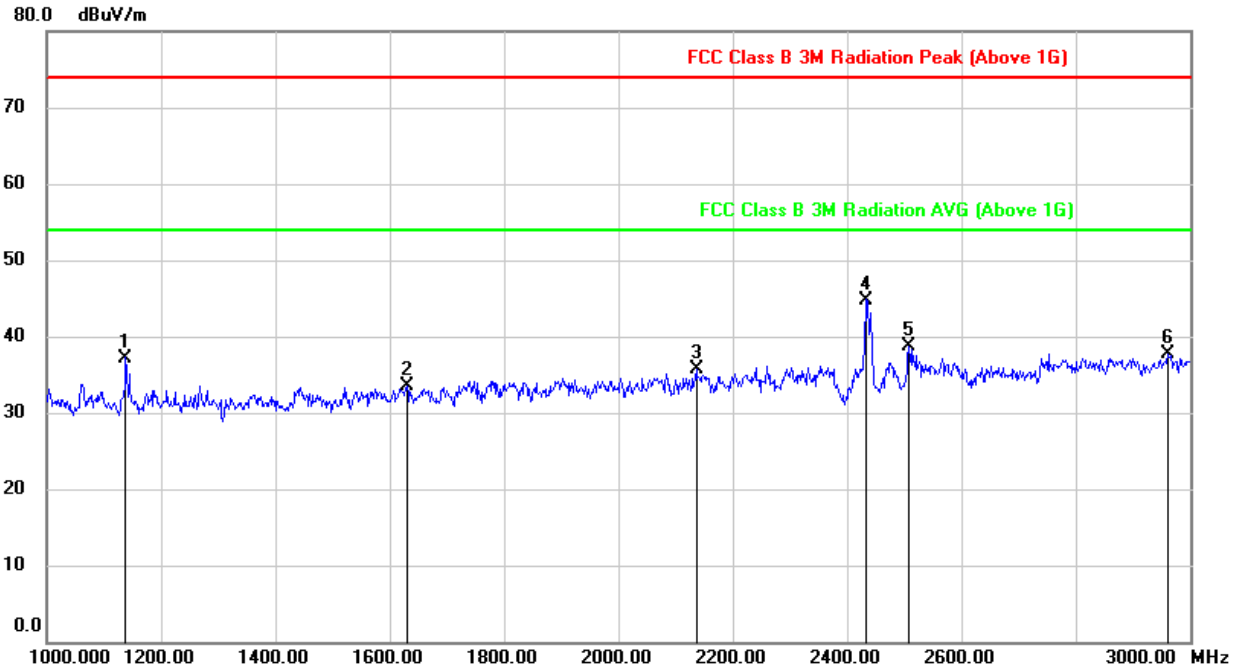

No.	Frequency (MHz)	Reading (dBuV)	Correct (dB/m)	Result (dBuV/m)	Limit (dBuV/m)	Margin (dB)	Remark
1	1138.000	50.64	-13.44	37.20	74.00	-36.80	peak
2	1630.000	45.00	-11.46	33.54	74.00	-40.46	peak
3	2136.000	44.85	-9.14	35.71	74.00	-38.29	peak
4	2434.000	52.51	-7.71	44.80	74.00	-29.20	peak
5	2508.000	45.91	-7.29	38.62	74.00	-35.38	peak
6	2960.000	43.09	-5.37	37.72	74.00	-36.28	peak

- Note: 1. Measurement = Reading Level + Correct Factor.
 2. If Peak Result complies with AV limit, AV Result is deemed to comply with AV limit.
 3. Peak: Peak detector.
 4. Filter losses were only considered in then spurious frequency bands and the authorized band was not corrected for BRF losses.
 5. Proper operation of the transmitter prior to adding the filter to the measurement chain.



HARMONICS AND SPURIOUS EMISSIONS (HIGH CHANNEL, HORIZONTAL)

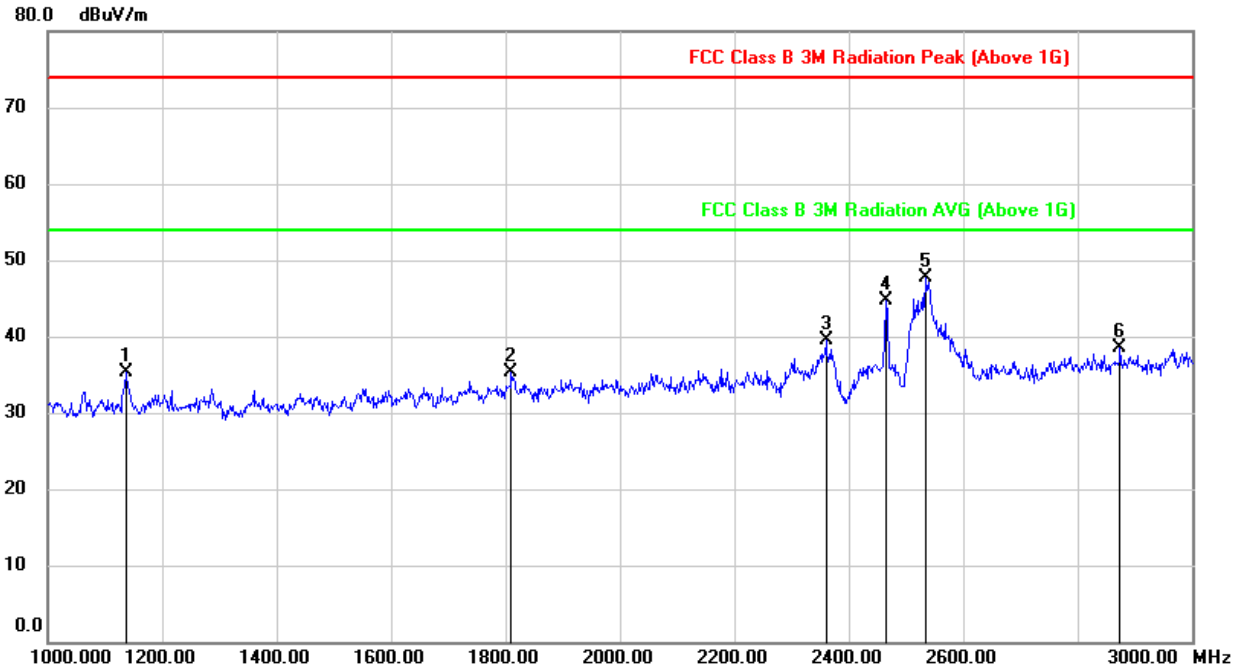

No.	Frequency (MHz)	Reading (dBuV)	Correct (dB/m)	Result (dBuV/m)	Limit (dBuV/m)	Margin (dB)	Remark
1	1136.000	48.80	-13.47	35.33	74.00	-38.67	peak
2	1810.000	45.49	-10.11	35.38	74.00	-38.62	peak
3	2360.000	47.62	-8.10	39.52	74.00	-34.48	peak
4	2466.000	52.20	-7.49	44.71	74.00	-29.29	peak
5	2534.000	55.04	-7.42	47.62	74.00	-26.38	peak
6	2874.000	44.18	-5.66	38.52	74.00	-35.48	peak

- Note: 1. Measurement = Reading Level + Correct Factor.
 2. If Peak Result complies with AV limit, AV Result is deemed to comply with AV limit.
 3. Peak: Peak detector.
 4. Filter losses were only considered in then spurious frequency bands and the authorized band was not corrected for BRF losses.
 5. Proper operation of the transmitter prior to adding the filter to the measurement chain.



HARMONICS AND SPURIOUS EMISSIONS (HIGH CHANNEL, VERTICAL)

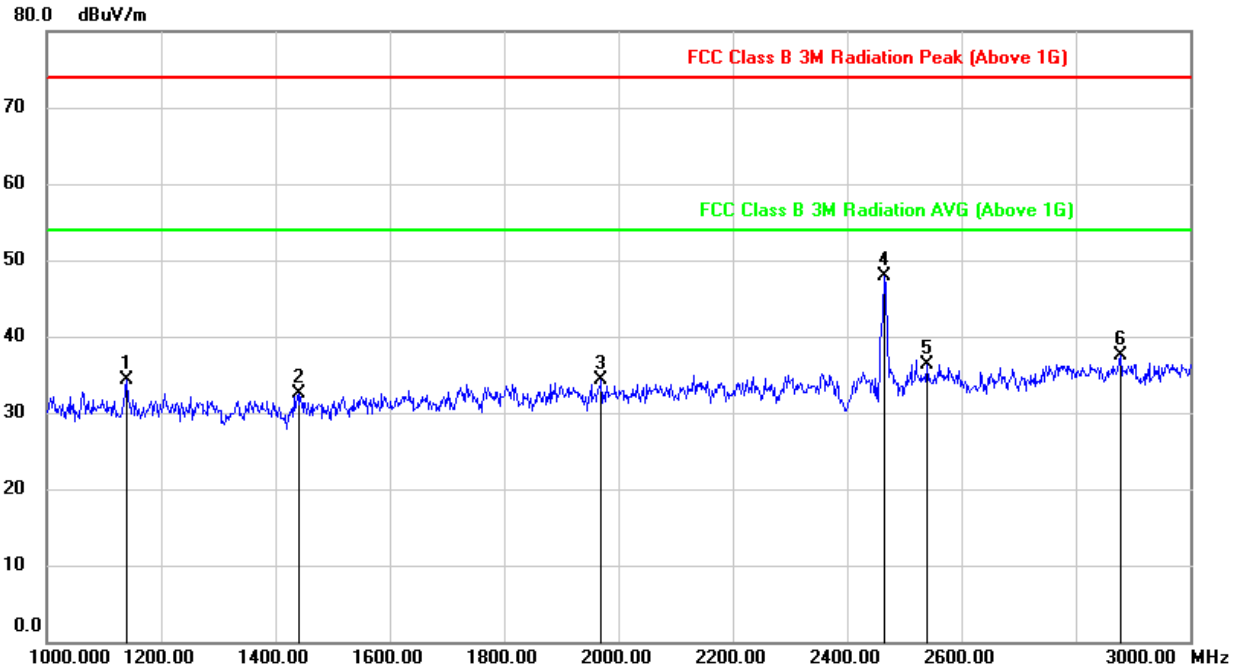

No.	Frequency (MHz)	Reading (dBuV)	Correct (dB/m)	Result (dBuV/m)	Limit (dBuV/m)	Margin (dB)	Remark
1	1140.000	47.65	-13.43	34.22	74.00	-39.78	peak
2	1442.000	44.95	-12.53	32.42	74.00	-41.58	peak
3	1970.000	44.43	-10.04	34.39	74.00	-39.61	peak
4	2466.000	55.41	-7.49	47.92	74.00	-26.08	peak
5	2540.000	43.82	-7.46	36.36	74.00	-37.64	peak
6	2878.000	43.08	-5.65	37.43	74.00	-36.57	peak

- Note: 1. Measurement = Reading Level + Correct Factor.
 2. If Peak Result complies with AV limit, AV Result is deemed to comply with AV limit.
 3. Peak: Peak detector.
 4. Filter losses were only considered in then spurious frequency bands and the authorized band was not corrected for BRF losses.
 5. Proper operation of the transmitter prior to adding the filter to the measurement chain.



9.4. SPURIOUS EMISSIONS (18~26GHz)

9.4.1. 802.11b MODE

SPURIOUS EMISSIONS (HIGH CHANNEL, WORST-CASE CONFIGURATION, HORIZONTAL)

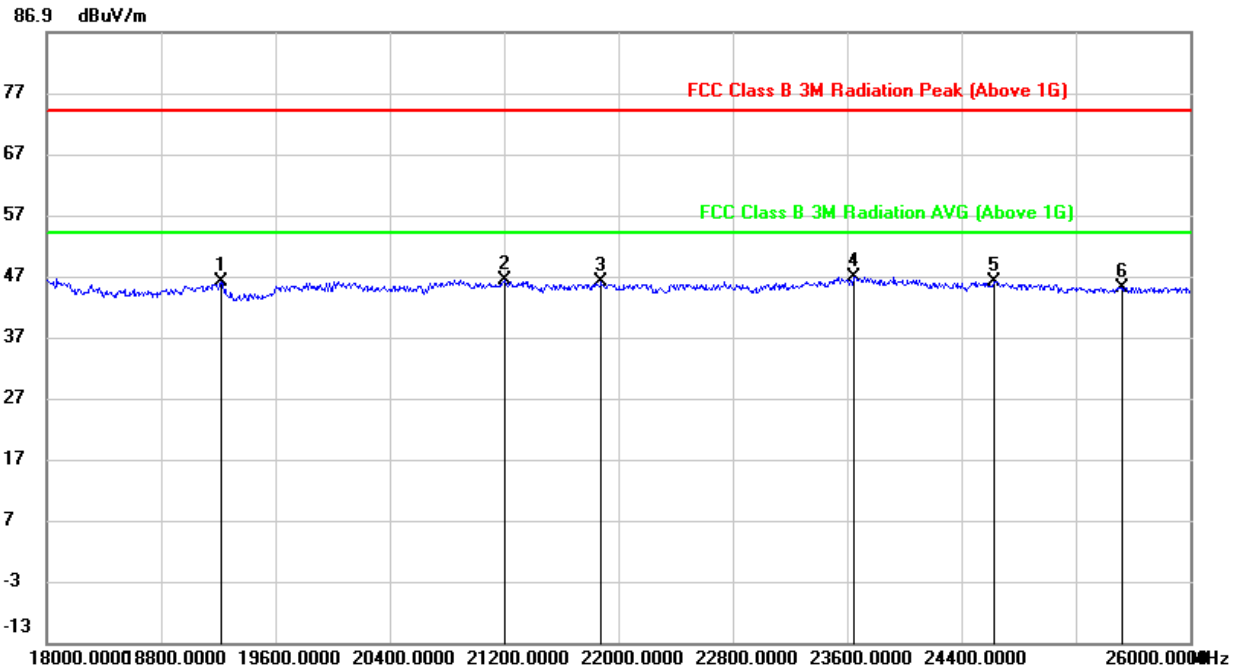

No.	Frequency (MHz)	Reading (dBuV)	Correct (dB/m)	Result (dBuV/m)	Limit (dBuV/m)	Margin (dB)	Remark
1	19216.000	51.12	-5.02	46.10	74.00	-27.90	peak
2	21200.000	51.65	-5.46	46.19	74.00	-27.81	peak
3	21880.000	52.15	-6.02	46.13	74.00	-27.87	peak
4	23648.000	51.57	-4.69	46.88	74.00	-27.12	peak
5	24632.000	48.33	-2.25	46.08	74.00	-27.92	peak
6	25520.000	46.93	-1.78	45.15	74.00	-28.85	peak

Note: 1. Measurement = Reading Level + Correct Factor.
 2. If Peak Result complies with AV limit, AV Result is deemed to comply with AV limit.
 3. Peak: Peak detector.
 4. The preamplifier only effect to the above 18GHz signal and no filter added to the measurement chain.



SPURIOUS EMISSIONS (HIGH CHANNEL, WORST-CASE CONFIGURATION, VERTICAL)

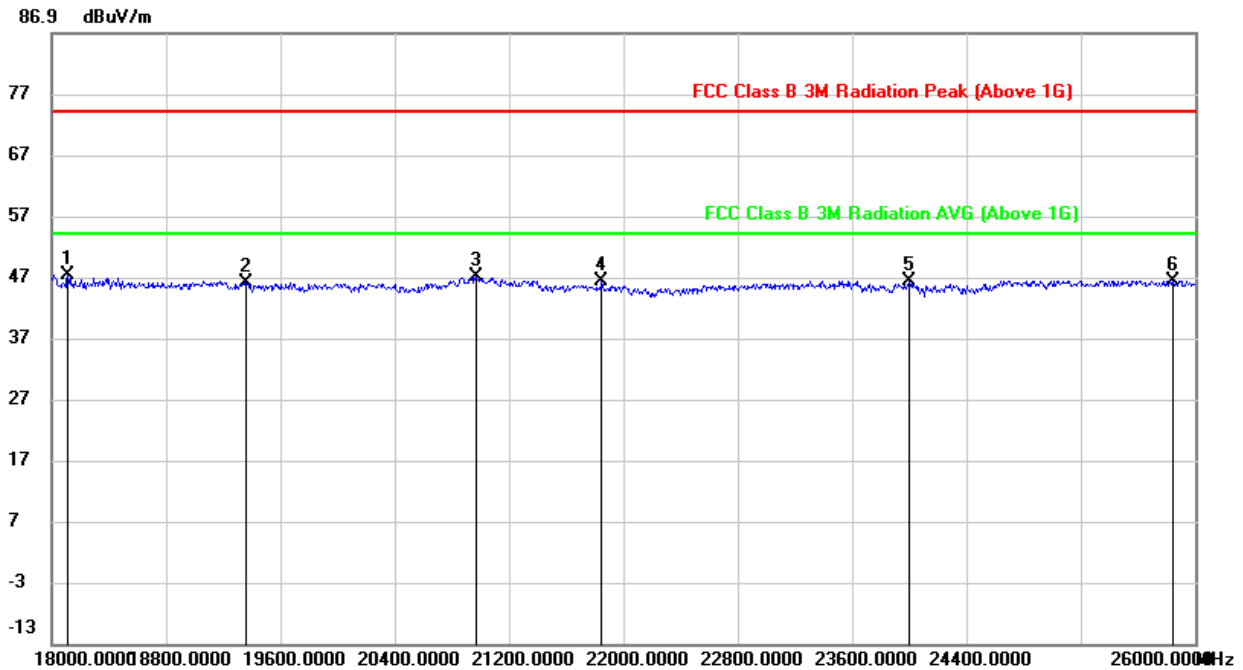

No.	Frequency (MHz)	Reading (dBuV)	Correct (dB/m)	Result (dBuV/m)	Limit (dBuV/m)	Margin (dB)	Remark
1	18112.000	51.35	-4.10	47.25	74.00	-26.75	peak
2	19360.000	51.04	-4.93	46.11	74.00	-27.89	peak
3	20968.000	52.31	-5.26	47.05	74.00	-26.95	peak
4	21848.000	52.26	-5.95	46.31	74.00	-27.69	peak
5	24000.000	50.41	-4.01	46.40	74.00	-27.60	peak
6	25840.000	48.10	-1.73	46.37	74.00	-27.63	peak

Note: 1. Measurement = Reading Level + Correct Factor.
 2. If Peak Result complies with AV limit, AV Result is deemed to comply with AV limit.
 3. Peak: Peak detector.
 4. The preamplifier only effect to the above 18GHz signal and no filter added to the measurement chain.

Note: All the test modes have been tested, only the worst data record in the report.



9.5. SPURIOUS EMISSIONS (0.03 ~ 1 GHz)

9.5.1. 802.11b MODE

SPURIOUS EMISSIONS (HIGH CHANNEL, WORST-CASE CONFIGURATION, HORIZONTAL)

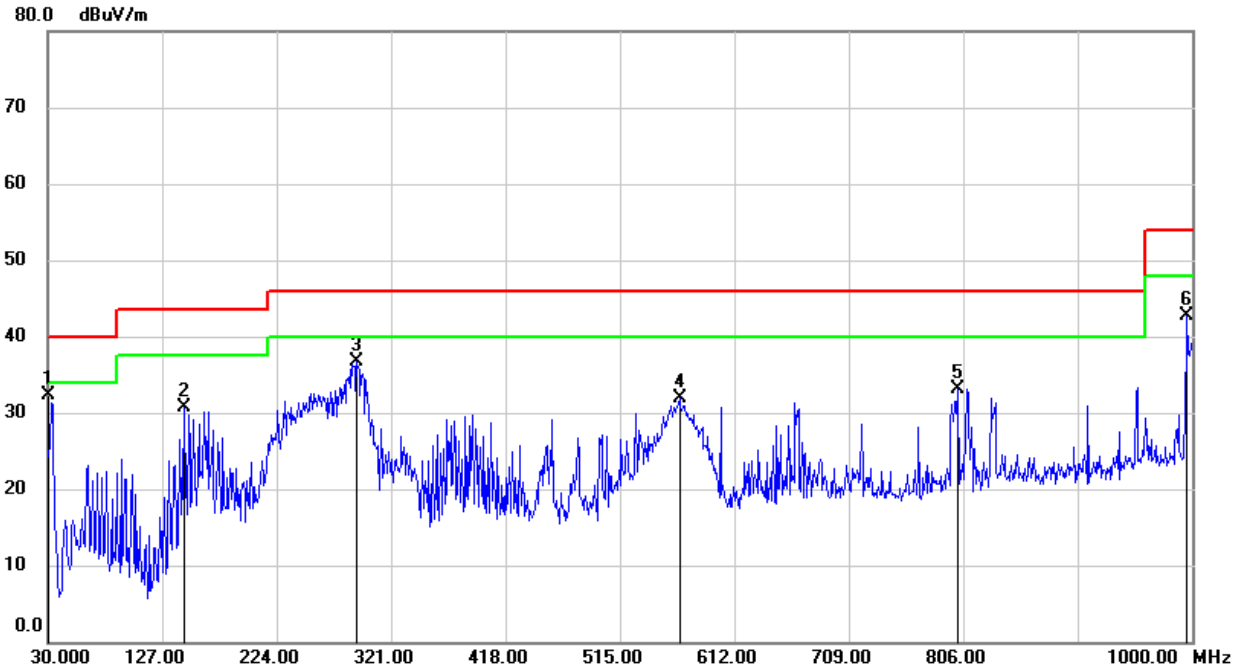

No.	Frequency (MHz)	Reading (dBuV)	Correct (dB/m)	Result (dBuV/m)	Limit (dBuV/m)	Margin (dB)	Remark
1	30.0000	49.29	-17.00	32.29	40.00	-7.71	QP
2	145.4299	49.38	-18.70	30.68	43.50	-12.82	QP
3	291.9000	51.09	-14.34	36.75	46.00	-9.25	QP
4	565.4400	40.95	-9.13	31.82	46.00	-14.18	QP
5	801.1500	38.33	-5.24	33.09	46.00	-12.91	QP
6	995.1500	45.74	-2.95	42.79	54.00	-11.21	QP

- Note: 1. Result Level = Read Level + Correct Factor.
 2. If Peak Result complies with QP limit, QP Result is deemed to comply with QP limit.
 3. Test setup: RBW: 120 kHz, VBW: 300 kHz, Sweep time: auto.



SPURIOUS EMISSIONS (HIGH CHANNEL, WORST-CASE CONFIGURATION, VERTICAL)

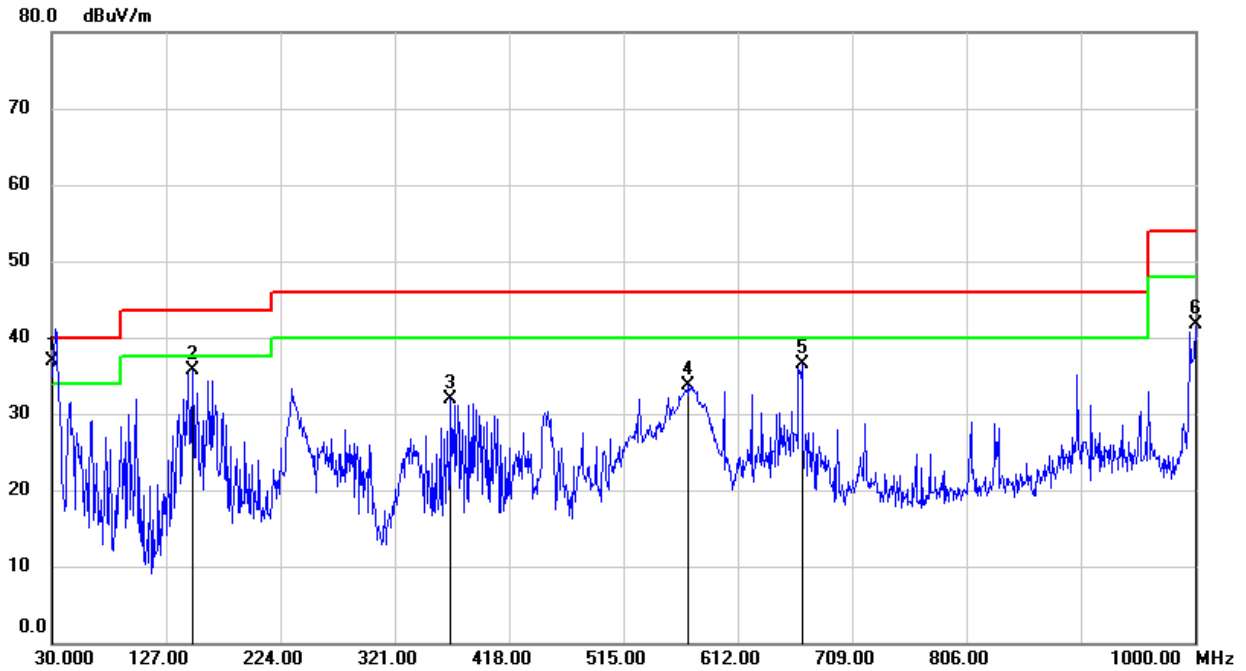

No.	Frequency (MHz)	Reading (dBuV)	Correct (dB/m)	Result (dBuV/m)	Limit (dBuV/m)	Margin (dB)	Remark
1	30.0000	53.92	-17.00	36.92	40.00	-3.08	QP
2	149.3100	54.09	-18.35	35.74	43.50	-7.76	QP
3	368.5300	44.68	-12.83	31.85	46.00	-14.15	QP
4	570.2900	42.79	-8.99	33.80	46.00	-12.20	QP
5	666.3200	43.74	-7.23	36.51	46.00	-9.49	QP
6	1000.0000	44.59	-2.84	41.75	54.00	-12.25	QP

- Note: 1. Result Level = Read Level + Correct Factor.
 2. If Peak Result complies with QP limit, QP Result is deemed to comply with QP limit.
 3. Test setup: RBW: 120 kHz, VBW: 300 kHz, Sweep time: auto

Note: All the test modes have been tested, only the worst data record in the report.



9.6. SPURIOUS EMISSIONS BELOW 30M

9.6.1. 802.11b MODE

SPURIOUS EMISSIONS (HIGH CHANNEL, LOOP ANTENNA FACE ON TO THE EUT, WORST-CASE CONFIGURATION)

0.09kHz~ 150kHz

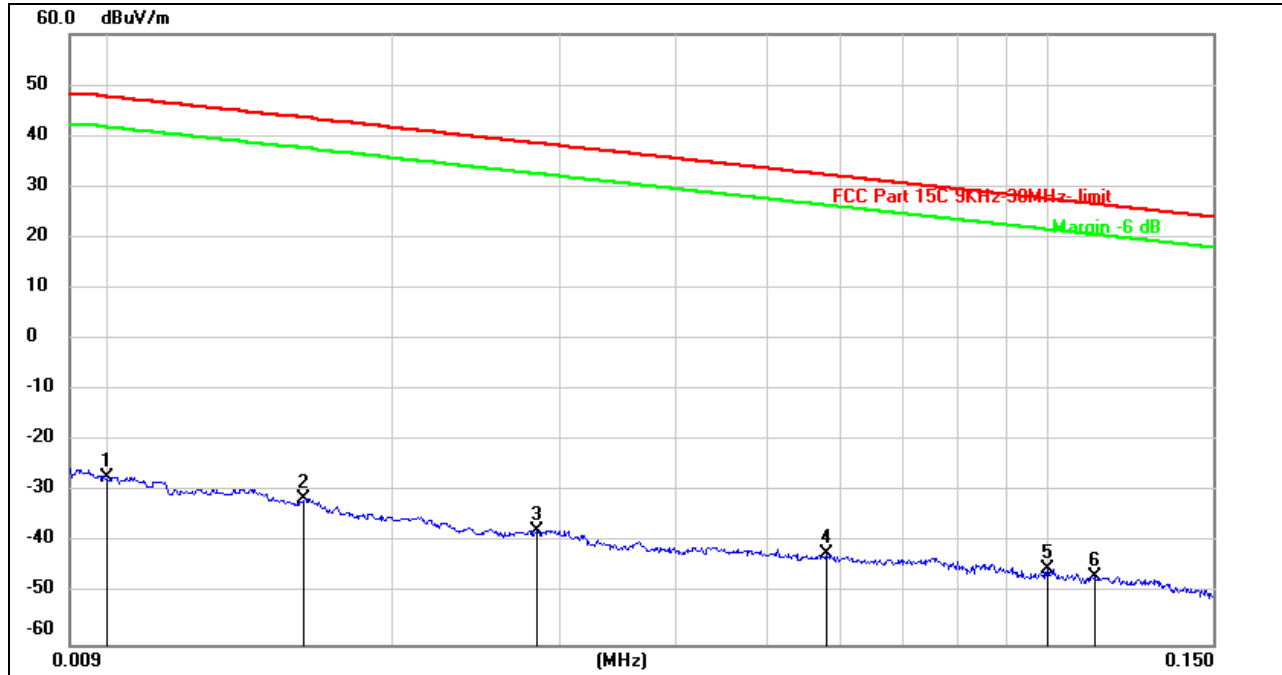

No.	Frequency (MHz)	Reading (dBuV)	Correct (dB/m)	Result (dBuV/m)	Limit (dBuV/m)	Margin (dB)	Remark
1	0.0100	74.35	-101.40	-27.05	47.60	-74.65	peak
2	0.0160	69.91	-101.37	-31.46	43.52	-74.98	peak
3	0.0284	63.86	-101.38	-37.52	38.54	-76.06	peak
4	0.0580	59.24	-101.51	-42.27	32.33	-74.60	peak
5	0.1000	56.67	-101.80	-45.13	27.60	-72.73	peak
6	0.1121	55.24	-101.76	-46.52	26.61	-73.13	peak

Note: 1. Measurement = Reading Level + Correct Factor.

2. If Peak Result complies with AV and QP limit, AV and QP Result are deemed to comply with AV limit.

3. All 3 polarizations(Horizontal, Face-on and Face-off) of the loop antenna had been tested, but only the worst data recorded in the report.



150kHz ~ 490kHz

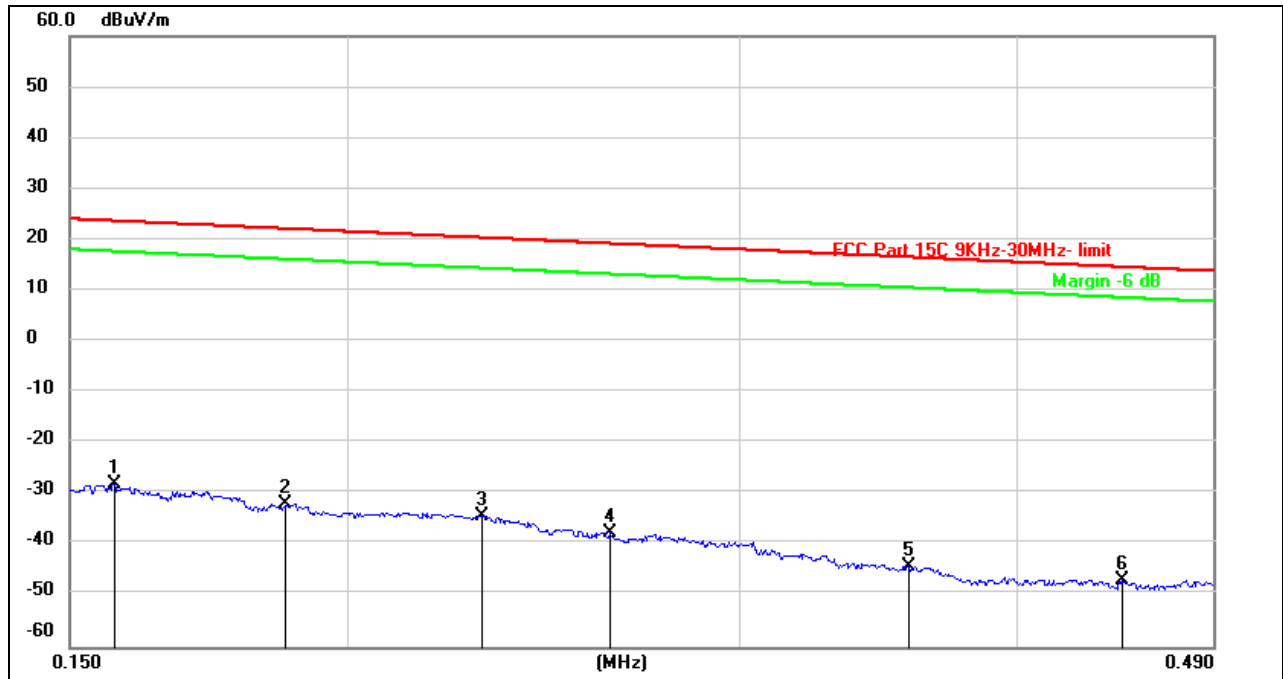

No.	Frequency (MHz)	Reading (dBuV)	Correct (dB/m)	Result (dBuV/m)	Limit (dBuV/m)	Margin (dB)	Remark
1	0.1570	73.53	-101.65	-28.12	23.68	-51.80	peak
2	0.1877	69.73	-101.70	-31.97	22.14	-54.11	peak
3	0.2298	67.55	-101.77	-34.22	20.37	-54.59	peak
4	0.2625	64.17	-101.82	-37.65	19.22	-56.87	peak
5	0.3577	57.69	-101.91	-44.22	16.53	-60.75	peak
6	0.4460	55.08	-102.01	-46.93	14.62	-61.55	peak

- Note: 1. Measurement = Reading Level + Correct Factor.
 2. If Peak Result complies with AV and QP limit, AV and QP Result are deemed to comply with AV limit.
 3. All 3 polarizations(Horizontal, Face-on and Face-off) of the loop antenna had been tested, but only the worst data recorded in the report.



490kHz ~ 30MHz

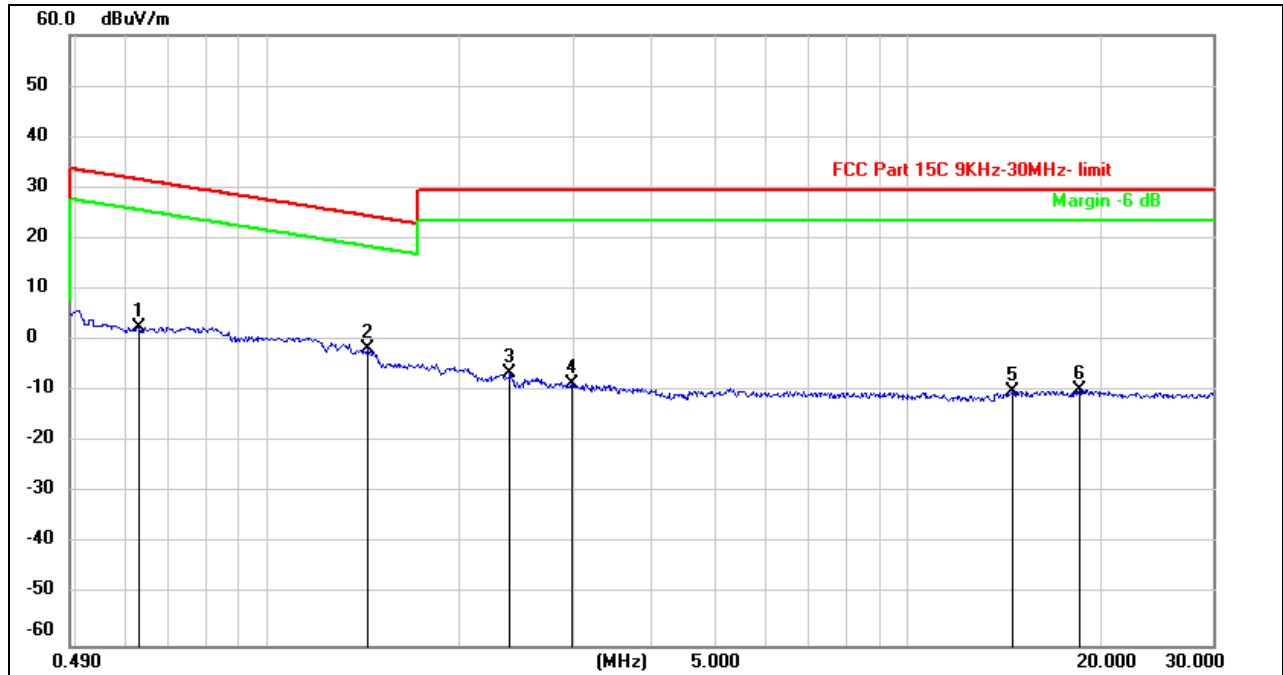

No.	Frequency (MHz)	Reading (dBuV)	Correct (dB/m)	Result (dBuV/m)	Limit (dBuV/m)	Margin (dB)	Remark
1	0.6298	64.67	-62.09	2.58	31.62	-29.04	peak
2	1.4275	60.38	-62.08	-1.70	24.51	-26.21	peak
3	2.3887	55.15	-61.72	-6.57	29.54	-36.11	peak
4	2.9830	53.00	-61.58	-8.58	29.54	-38.12	peak
5	14.5663	50.97	-61.00	-10.03	29.54	-39.57	peak
6	18.6091	51.14	-60.89	-9.75	29.54	-39.29	peak

Note: 1. Measurement = Reading Level + Correct Factor.

2. If Peak Result complies with AV and QP limit, AV and QP Result are deemed to comply with AV limit.

3. All 3 polarizations(Horizontal, Face-on and Face-off) of the loop antenna had been tested, but only the worst data recorded in the report.

Note: All the test modes have been tested, only the worst data record in the report.

10. AC POWER LINE CONDUCTED EMISSIONS

LIMITS

Please refer to CFR 47 FCC §15.207 (a) and ISED RSS-Gen Clause 8.8

FREQUENCY (MHz)	Quasi-peak	Average
0.15 -0.5	66 - 56 *	56 - 46 *
0.50 -5.0	56.00	46.00
5.0 -30.0	60.00	50.00

TEST SETUP AND PROCEDURE

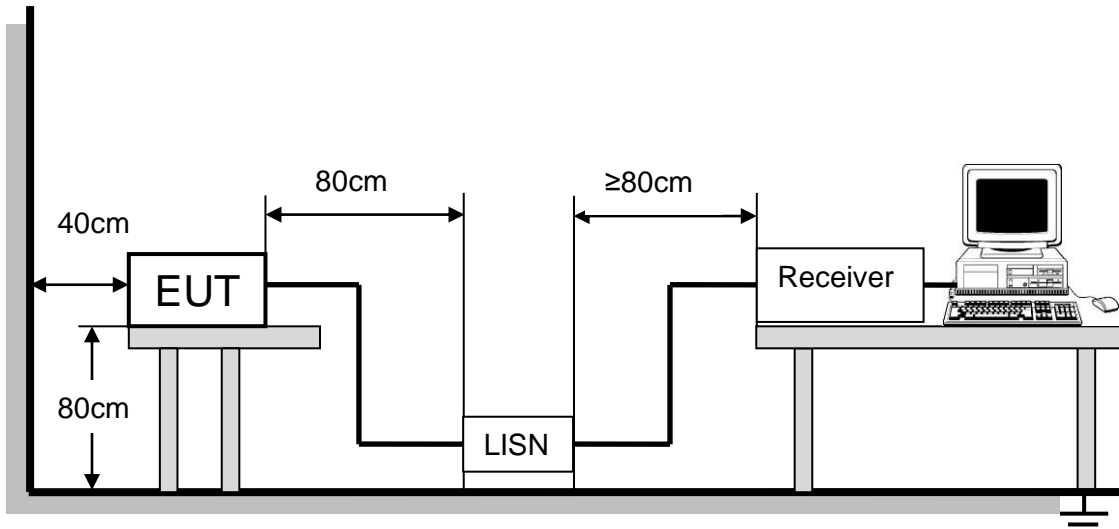

The EUT is put on a table of non-conducting material that is 80cm high. The vertical conducting wall of shielding is located 40cm to the rear of the EUT. The power line of the EUT is connected to the AC mains through a Artificial Mains Network (A.M.N.). A EMI Measurement Receiver (R&S Test Receiver ESR3) is used to test the emissions from both sides of AC line. According to the requirements in Section 6.2 of ANSI C63.10-2013. Conducted emissions from the EUT measured in the frequency range between 0.15 MHz and 30MHz using CISPR Quasi-Peak and average detector mode. The bandwidth of EMI test receiver is set at 9kHz.

The arrangement of the equipment is installed to meet the standards and operating in a manner, which tends to maximize its emission characteristics in a normal application.

TEST ENVIRONMENT

Temperature	24.1°C	Relative Humidity	50%
Atmosphere Pressure	101kPa	Test Voltage	AC 120V, 60Hz



TEST RESULTS

10.1. 802.11b MODE

LINE N RESULTS (HIGH CHANNEL, WORST-CASE CONFIGURATION)

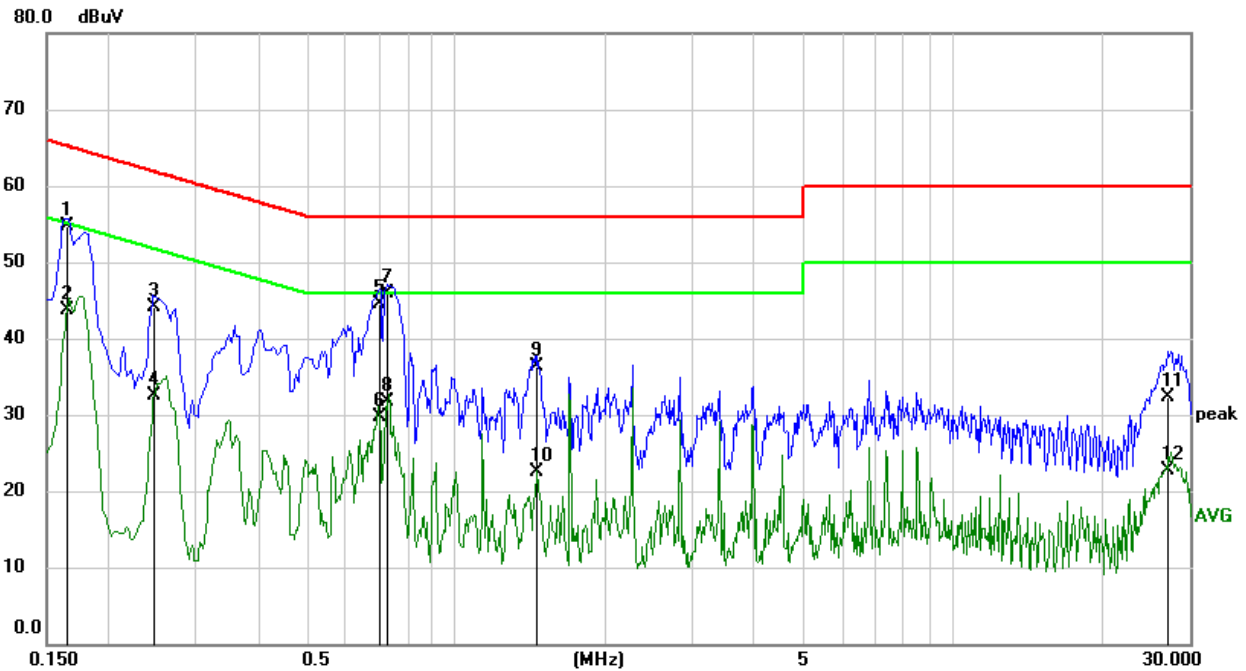

No.	Frequency (MHz)	Reading (dBuV)	Correct (dB)	Result (dBuV)	Limit (dBuV)	Margin (dB)	Remark
1	0.1648	45.20	9.60	54.80	65.22	-10.42	QP
2	0.1648	34.13	9.60	43.73	55.22	-11.49	AVG
3	0.2475	34.45	9.60	44.05	61.84	-17.79	QP
4	0.2475	22.89	9.60	32.49	51.84	-19.35	AVG
5	0.6997	34.99	9.60	44.59	56.00	-11.41	QP
6	0.6997	20.09	9.60	29.69	46.00	-16.31	AVG
7	0.7310	36.21	9.60	45.81	56.00	-10.19	QP
8	0.7310	22.14	9.60	31.74	46.00	-14.26	AVG
9	1.4605	26.74	9.61	36.35	56.00	-19.65	QP
10	1.4605	12.94	9.61	22.55	46.00	-23.45	AVG
11	27.2077	22.38	9.99	32.37	60.00	-27.63	QP
12	27.2077	12.79	9.99	22.78	50.00	-27.22	AVG

- Note: 1. Result = Reading +Correct Factor.
 2. If QP Result complies with AV limit, AV Result is deemed to comply with AV limit.
 3. Test setup: RBW: 200 Hz (9 kHz-150 kHz), 9 kHz (150 kHz-30 MHz).
 4. Step size: 80Hz (0.009MHz-0.15MHz), 4 kHz (0.15MHz-30MHz), Scan time: auto.



LINE L RESULTS (HIGH CHANNEL, WORST-CASE CONFIGURATION)

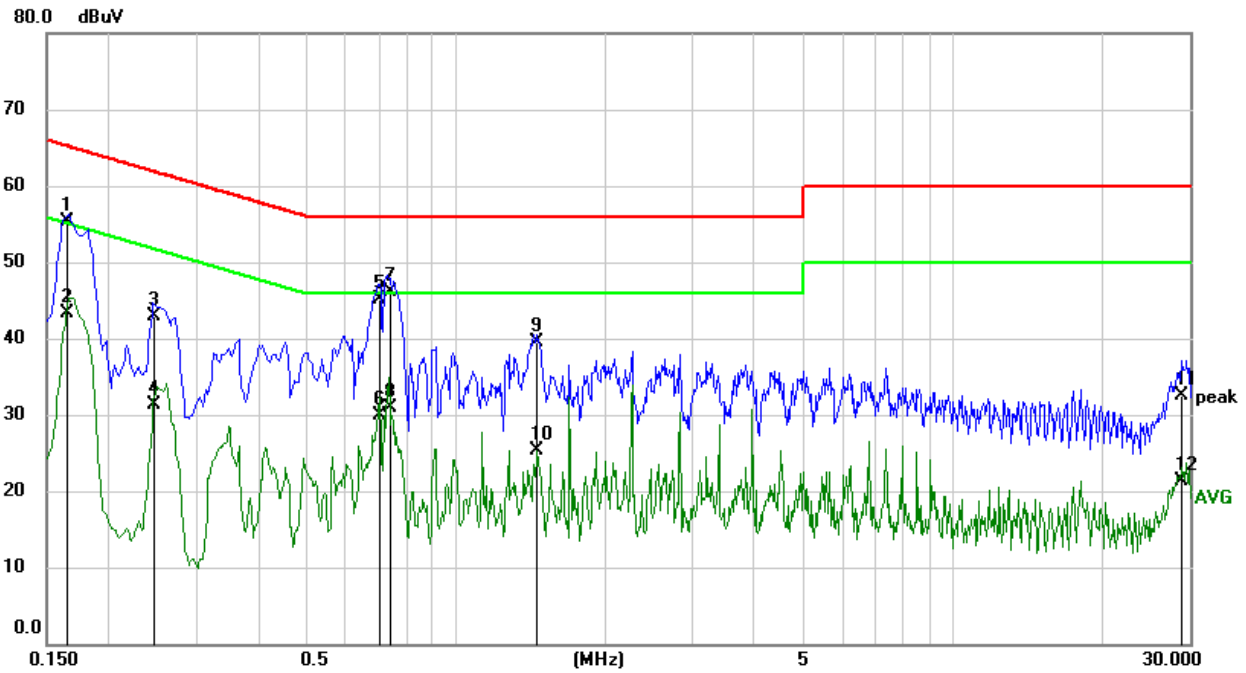

No.	Frequency (MHz)	Reading (dBuV)	Correct (dB)	Result (dBuV)	Limit (dBuV)	Margin (dB)	Remark
1	0.1647	45.77	9.61	55.38	65.22	-9.84	QP
2	0.1647	33.74	9.61	43.35	55.22	-11.87	AVG
3	0.2472	33.36	9.60	42.96	61.85	-18.89	QP
4	0.2472	21.71	9.60	31.31	51.85	-20.54	AVG
5	0.7013	35.53	9.60	45.13	56.00	-10.87	QP
6	0.7013	20.23	9.60	29.83	46.00	-16.17	AVG
7	0.7382	36.46	9.60	46.06	56.00	-9.94	QP
8	0.7382	21.25	9.60	30.85	46.00	-15.15	AVG
9	1.4604	29.86	9.61	39.47	56.00	-16.53	QP
10	1.4604	15.72	9.61	25.33	46.00	-20.67	AVG
11	29.0247	22.64	9.81	32.45	60.00	-27.55	QP
12	29.0247	11.41	9.81	21.22	50.00	-28.78	AVG

- Note: 1. Result = Reading +Correct Factor.
 2. If QP Result complies with AV limit, AV Result is deemed to comply with AV limit.
 3. Test setup: RBW: 200 Hz (9 kHz-150 kHz), 9 kHz (150 kHz-30 MHz).
 4. Step size: 80Hz (0.009MHz-0.15MHz), 4 kHz (0.15MHz-30MHz), Scan time: auto.

Note: All the test modes have been tested, only the worst data record in the report.



11. ANTENNA REQUIREMENTS

APPLICABLE REQUIREMENTS

Please refer to FCC §15.203

An intentional radiator shall be designed to ensure that no antenna other than that furnished by the responsible party shall be used with the device. The use of a permanently attached antenna or of an antenna that uses a unique coupling to the intentional radiator shall be considered sufficient to comply with the provisions of this section. The manufacturer may design the unit so that a broken antenna can be replaced by the user, but the use of a standard antenna jack or electrical connector is prohibited.

Please refer to FCC §15.247(b)(4)

The conducted output power limit specified in paragraph (b) of this section is based on the use of antennas with directional gains that do not exceed 6 dBi. Except as shown in paragraph (c) of this section, if transmitting antennas of directional gain greater than 6 dBi are used, the conducted output power from the intentional radiator shall be reduced below the stated values in paragraphs (b)(1), (b)(2), and (b)(3) of this section, as appropriate, by the amount in dB that the directional gain of the antenna exceeds 6 dBi.

RESULTS

Complies



Appendix E): Band-edge for RF Conducted Emissions

Result Table

Mode	Channel	Carrier Power[dBm]	Max.Spurious Level [dBm]	Limit [dBm]	Verdict
11b	LCH	6.818	-29.827	-13.18	PASS
11b	HCH	7.858	-40.166	-12.14	PASS
11g	LCH	2.848	-27.045	-17.15	PASS
11g	HCH	3.573	-37.118	-16.43	PASS
11n HT20	LCH	1.927	-32.747	-18.07	PASS
11n HT20	HCH	2.534	-40.208	-17.47	PASS

Test Graph

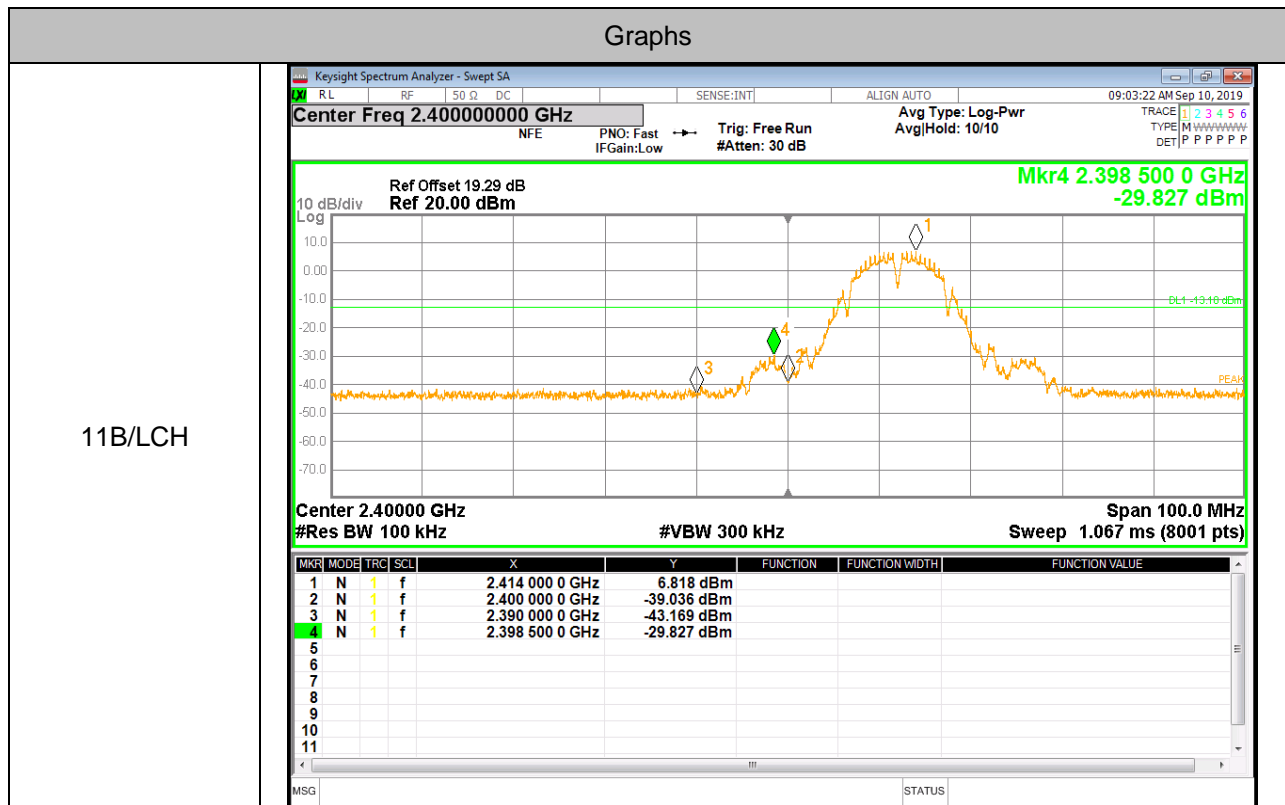

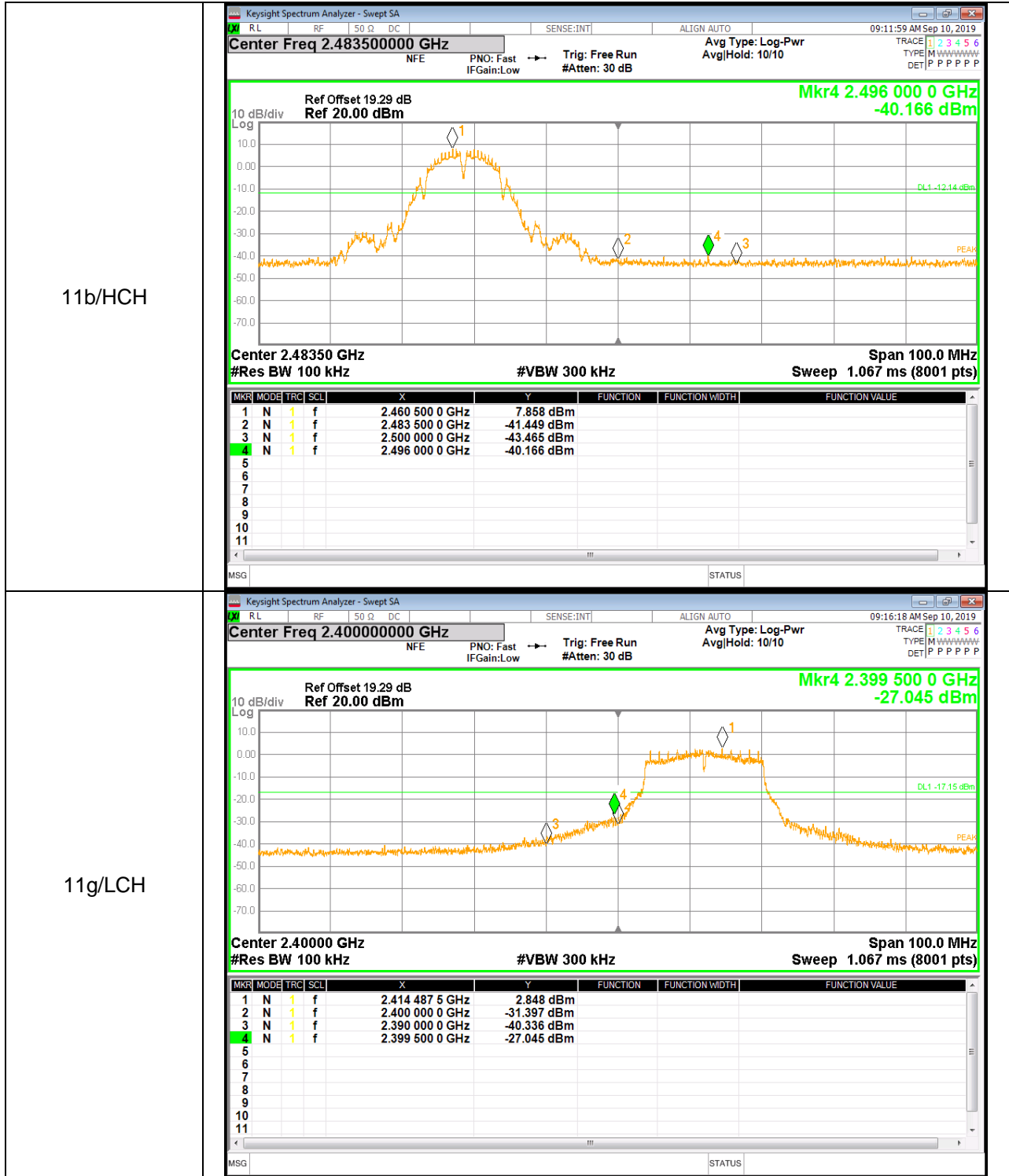

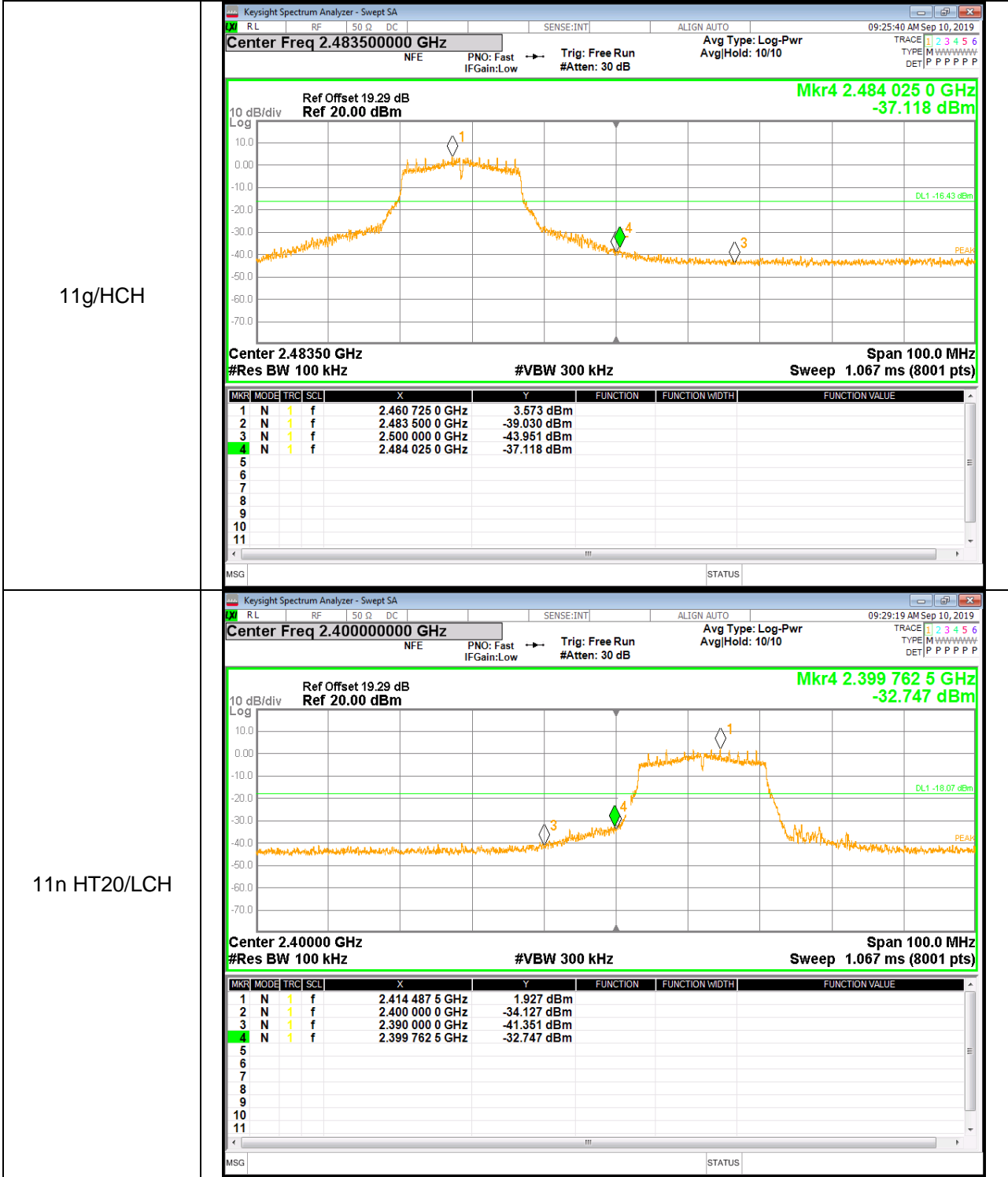



11n HT20/HCH

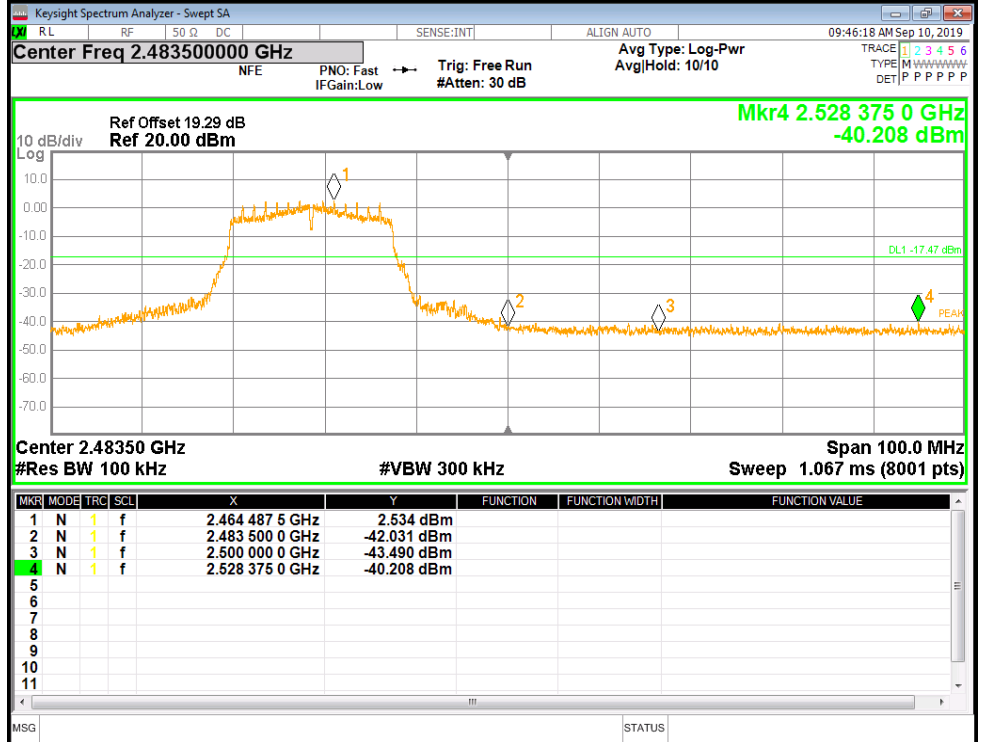



Appendix F): RF Conducted Spurious Emissions

Result Table

Mode	Channel	Pref [dBm]	Puw[dBm]	Verdict
11b	LCH	6.978	<Limit	PASS
11b	MCH	7.254	<Limit	PASS
11b	HCH	7.824	<Limit	PASS
11g	LCH	2.814	<Limit	PASS
11g	MCH	3.086	<Limit	PASS
11g	HCH	3.534	<Limit	PASS
11n HT20	LCH	1.86	<Limit	PASS
11n HT20	MCH	2.34	<Limit	PASS
11n HT20	HCH	2.392	<Limit	PASS

Test Graph

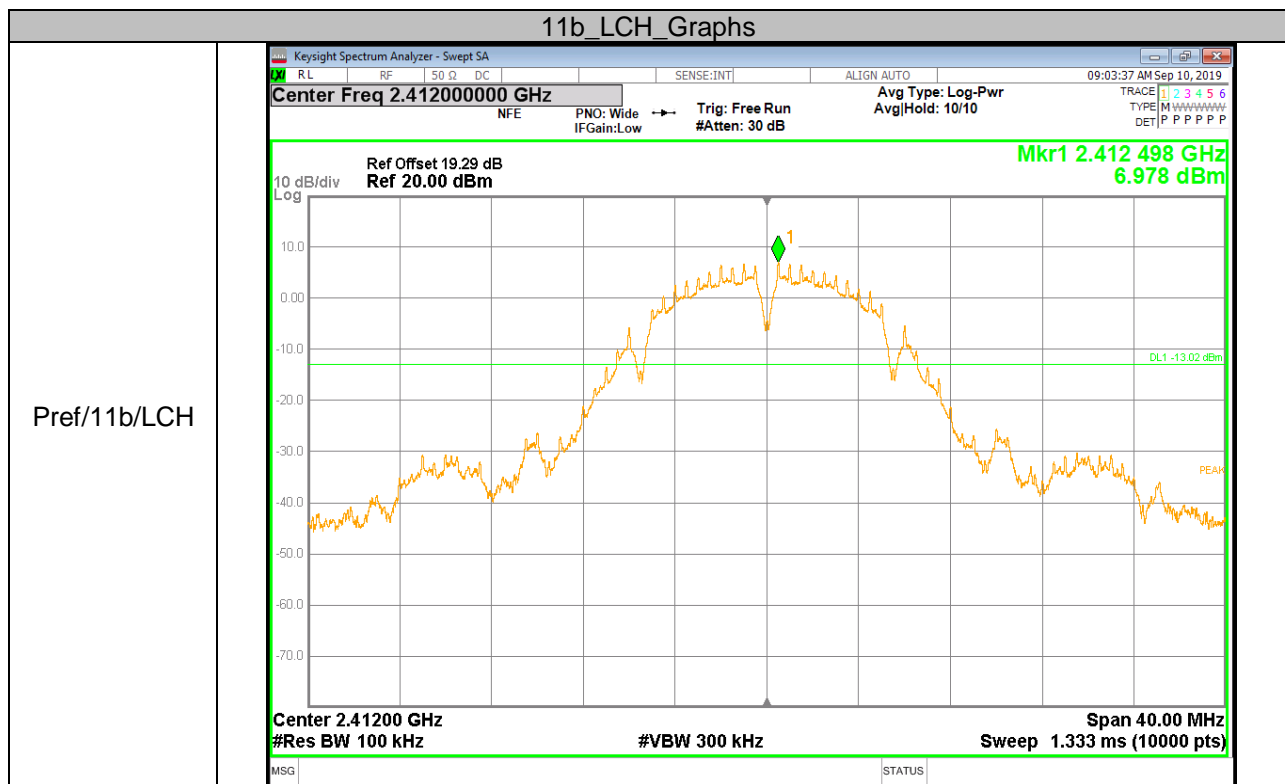



Puw/11b/LCH

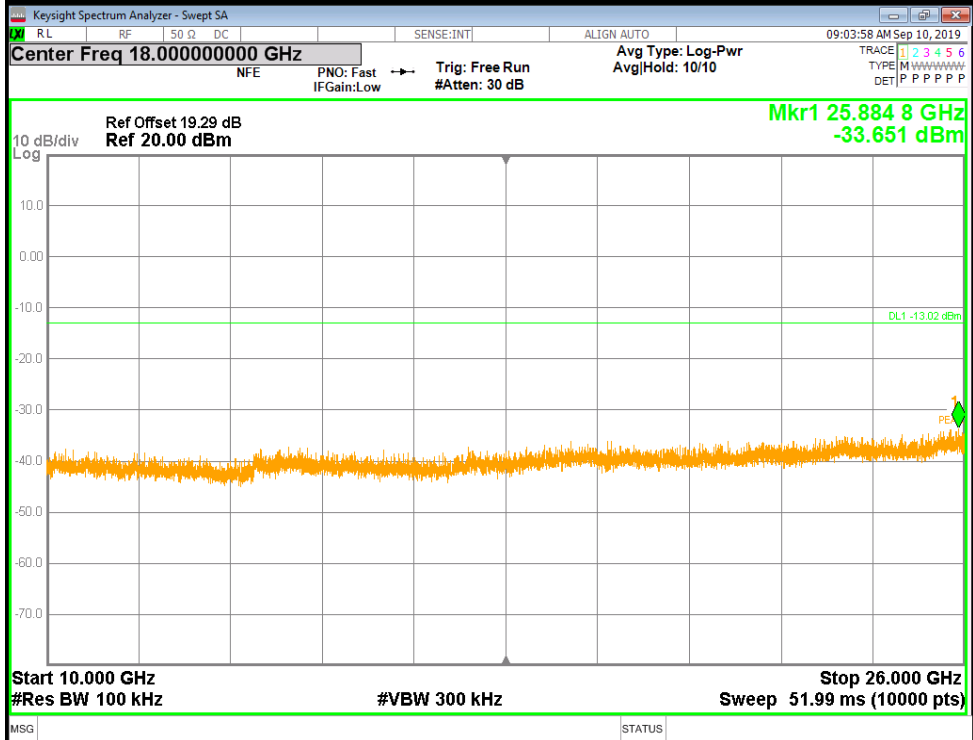
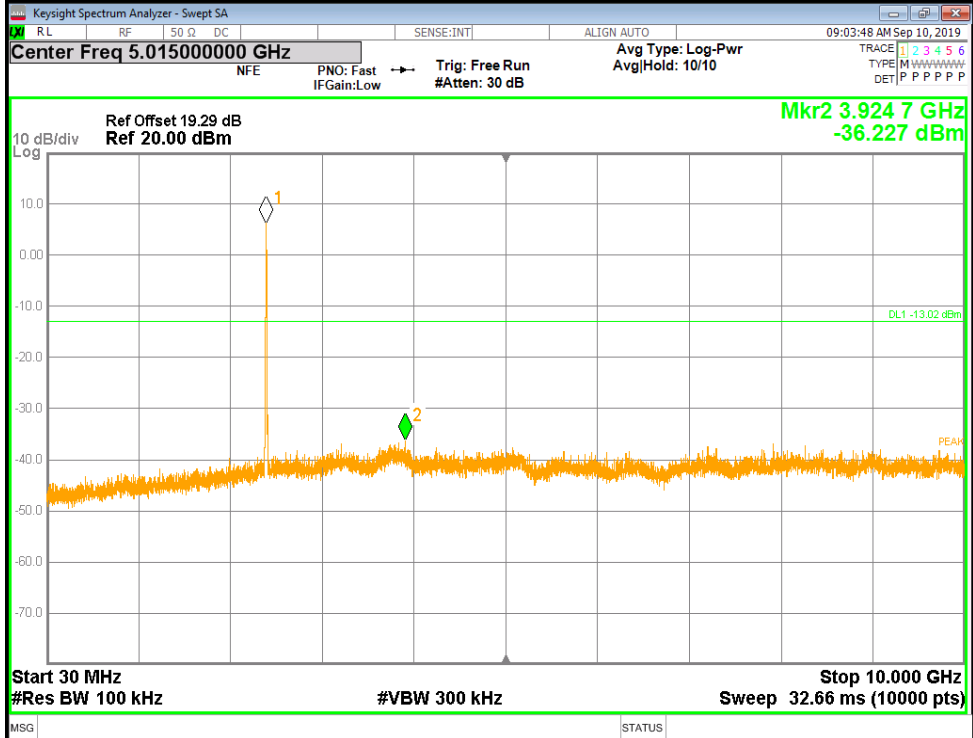

11b_MCH_Graphs

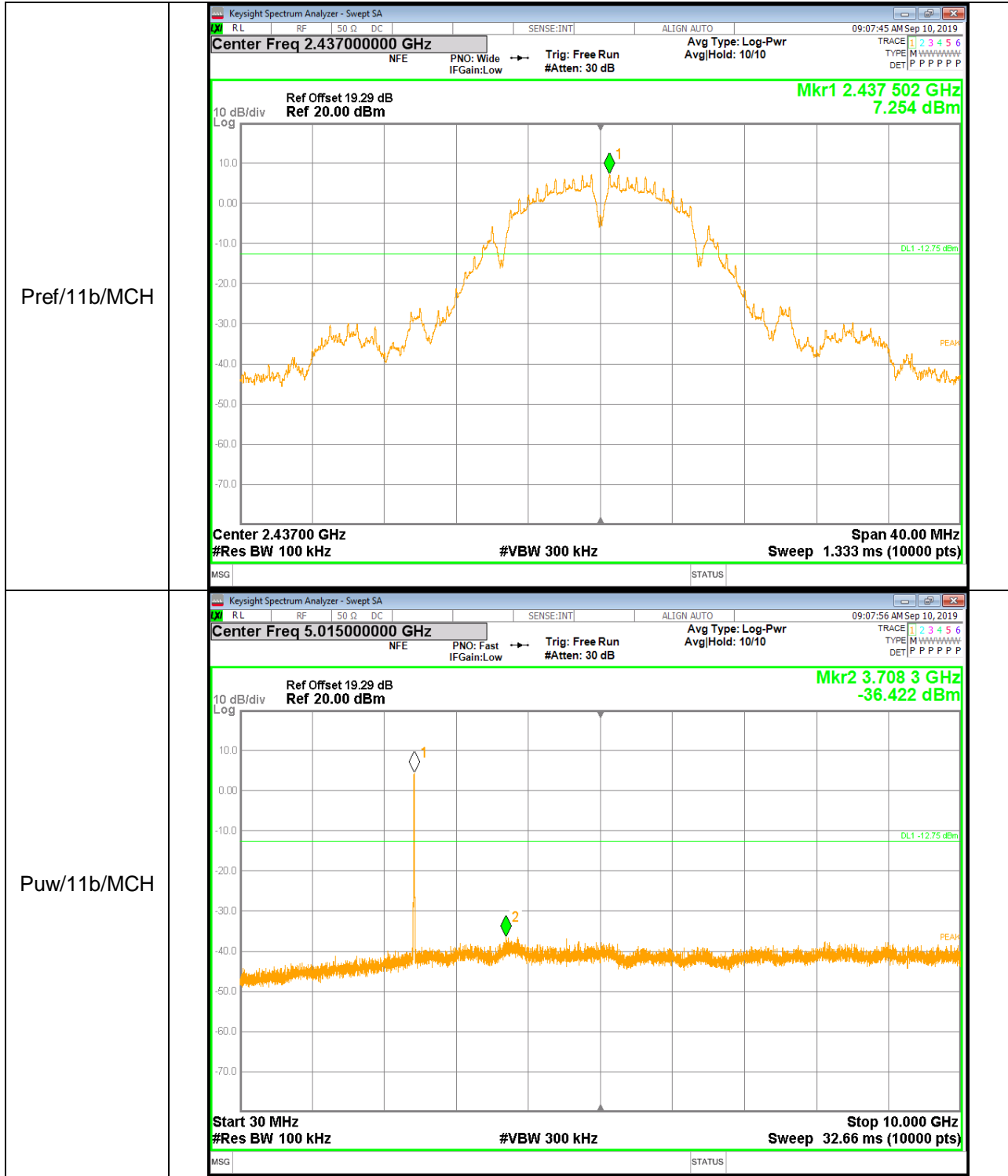

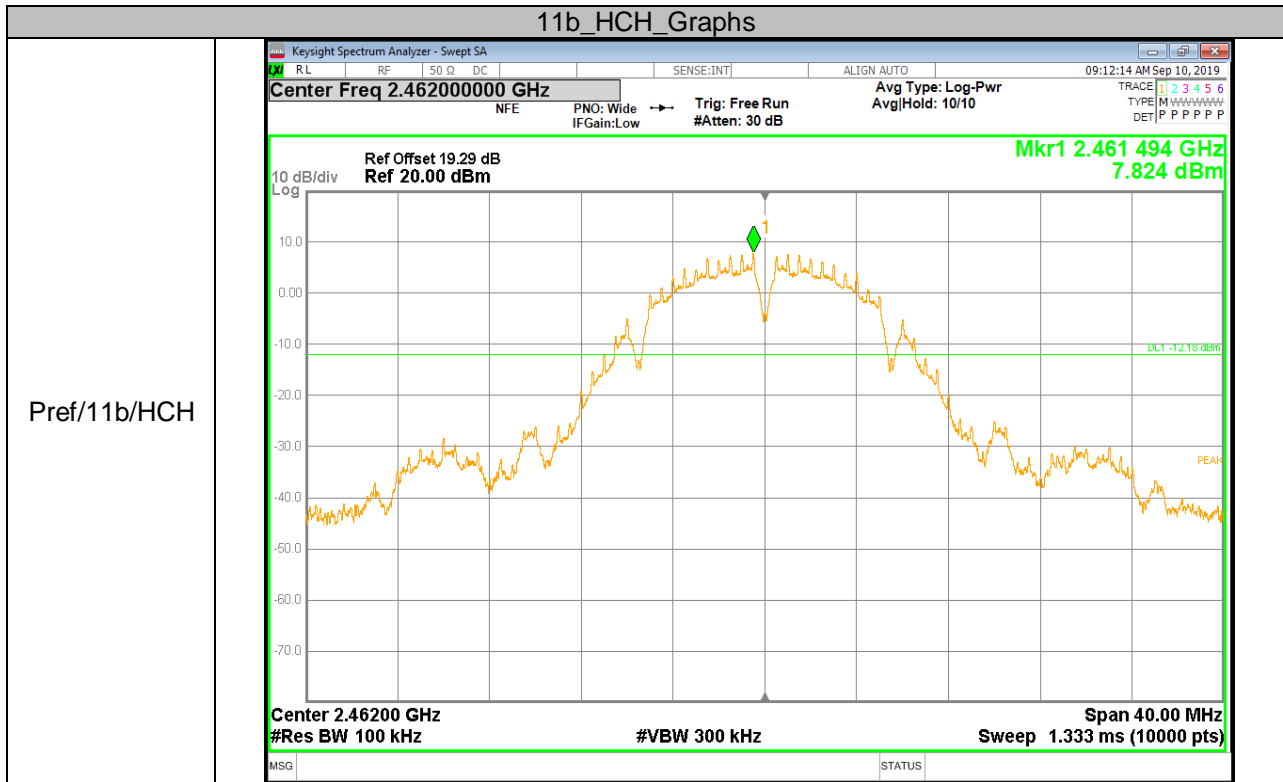
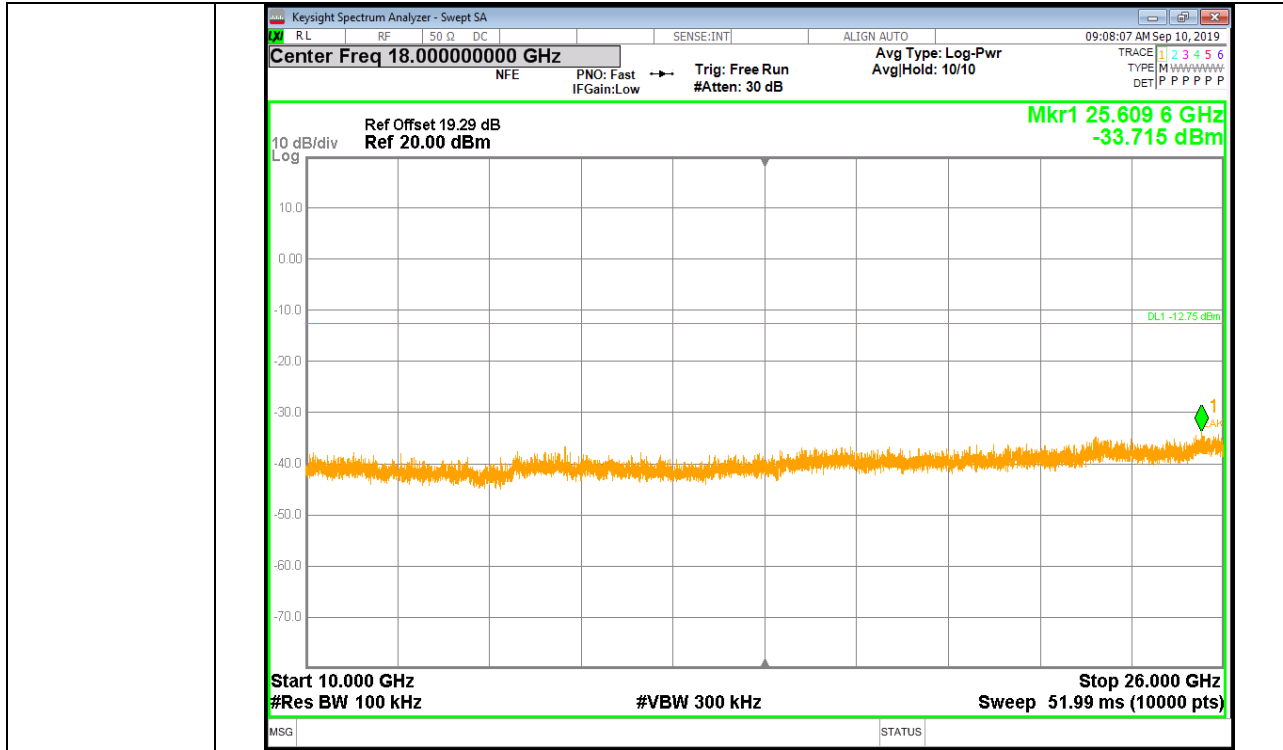

Pref/11b/HCH



Puw/11b/HCH

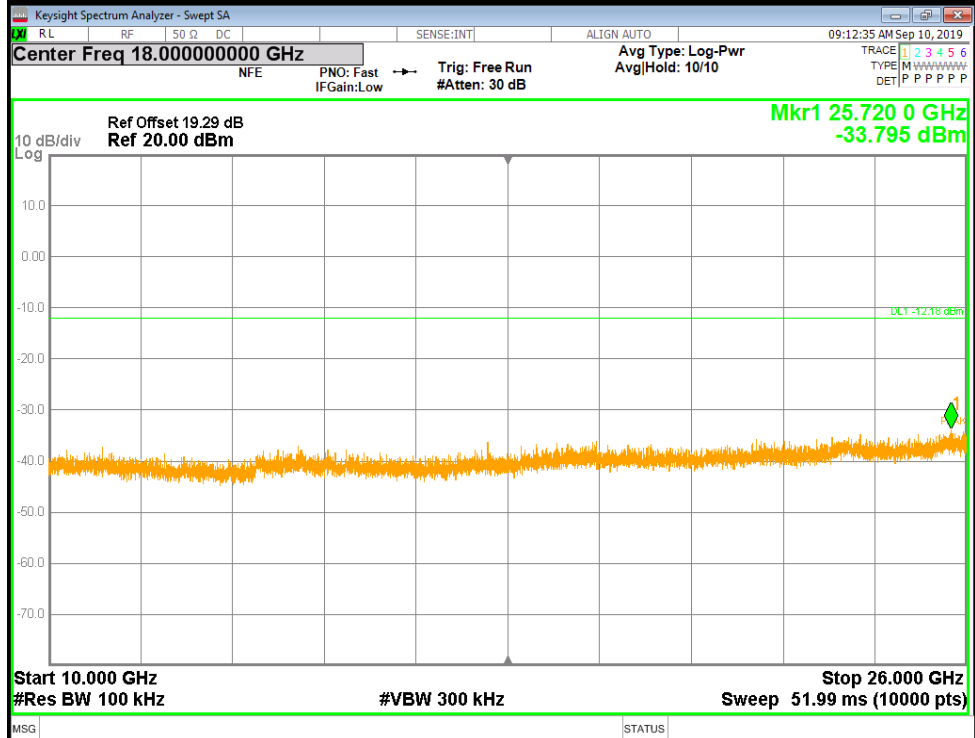
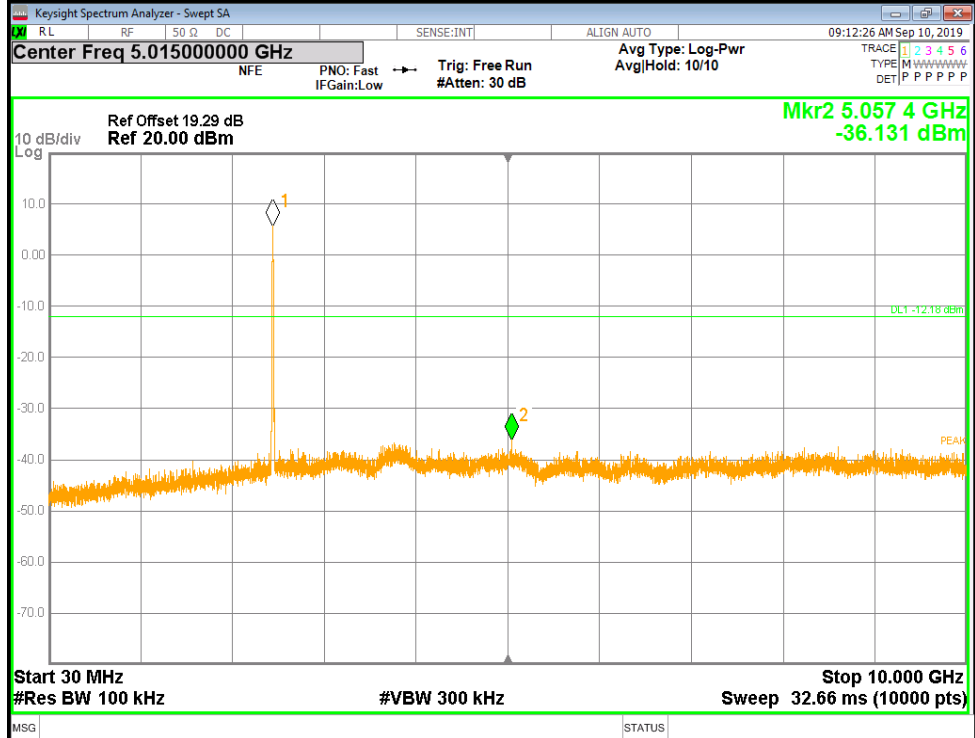

11g_LCH_Graphs

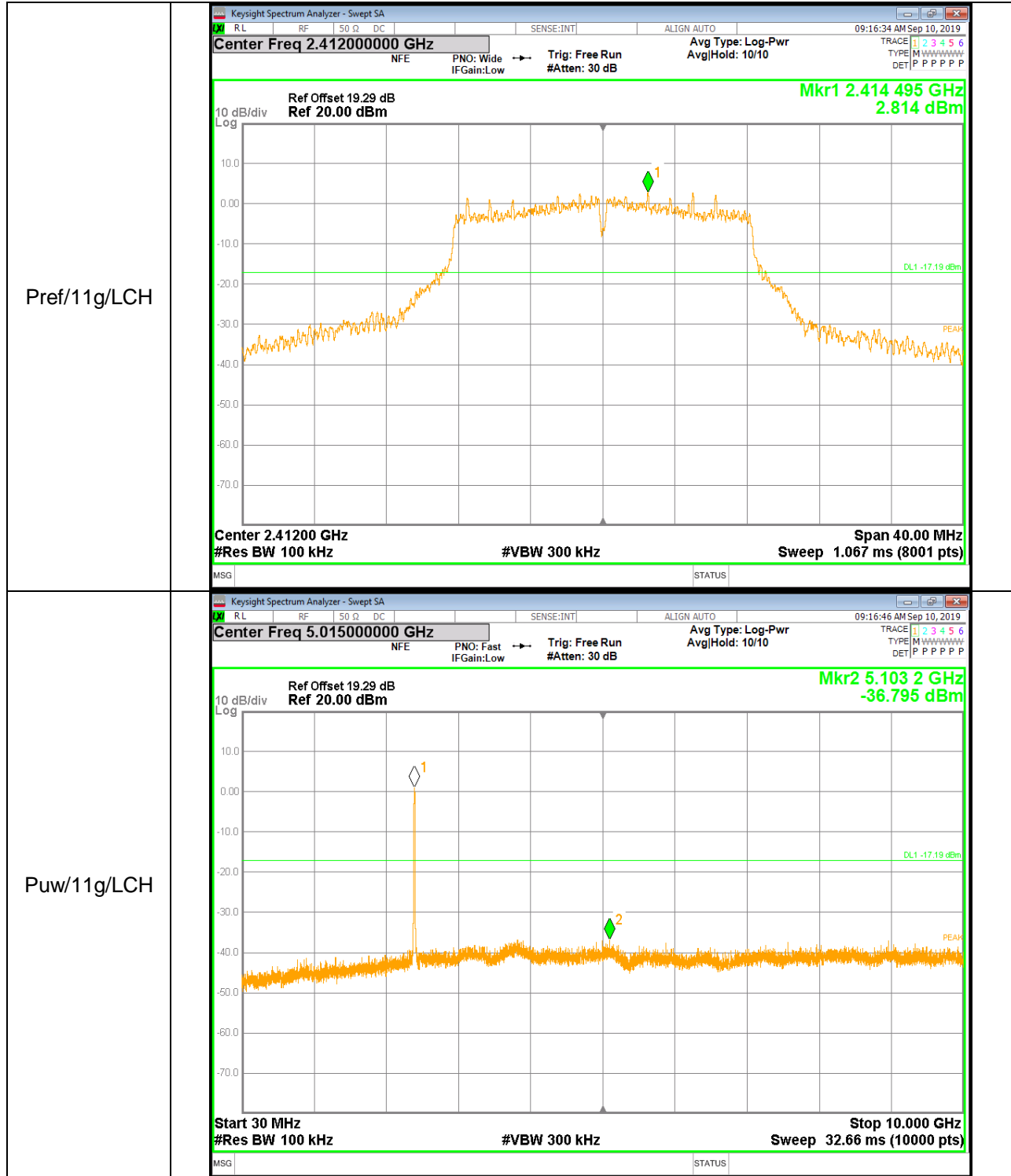

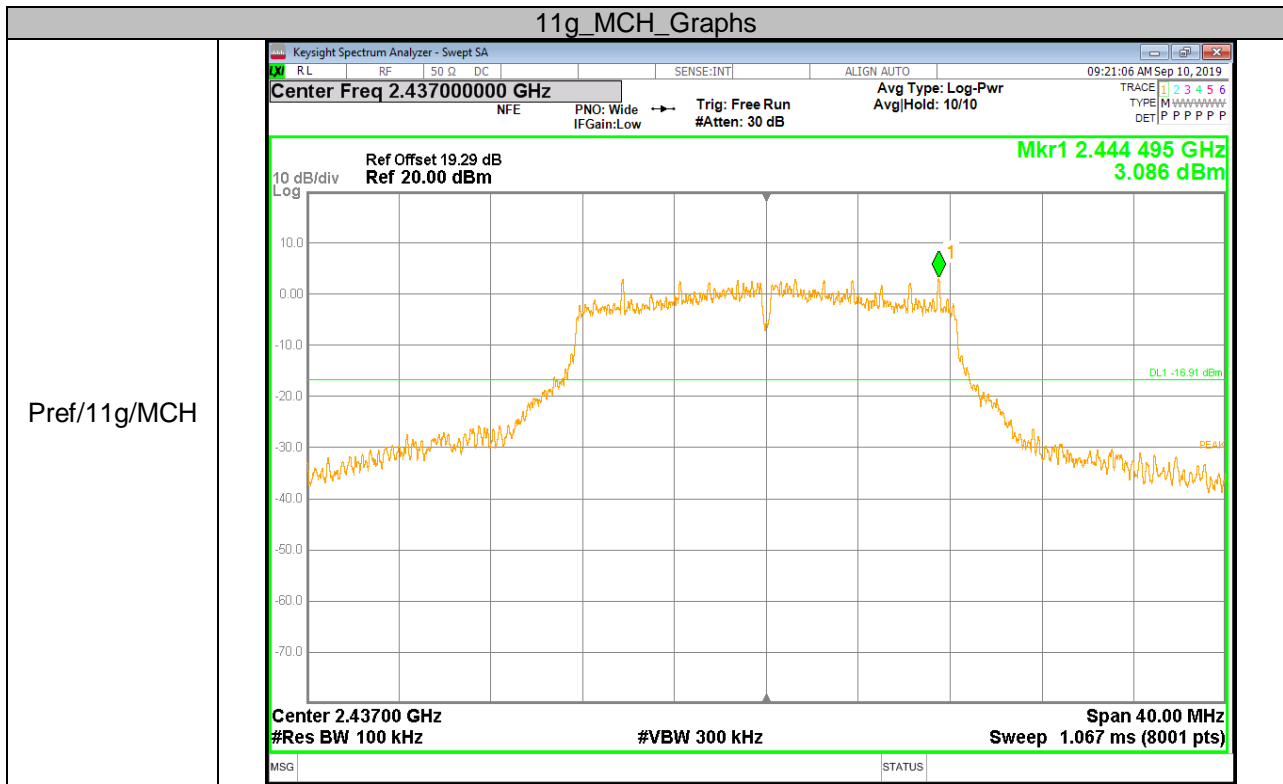
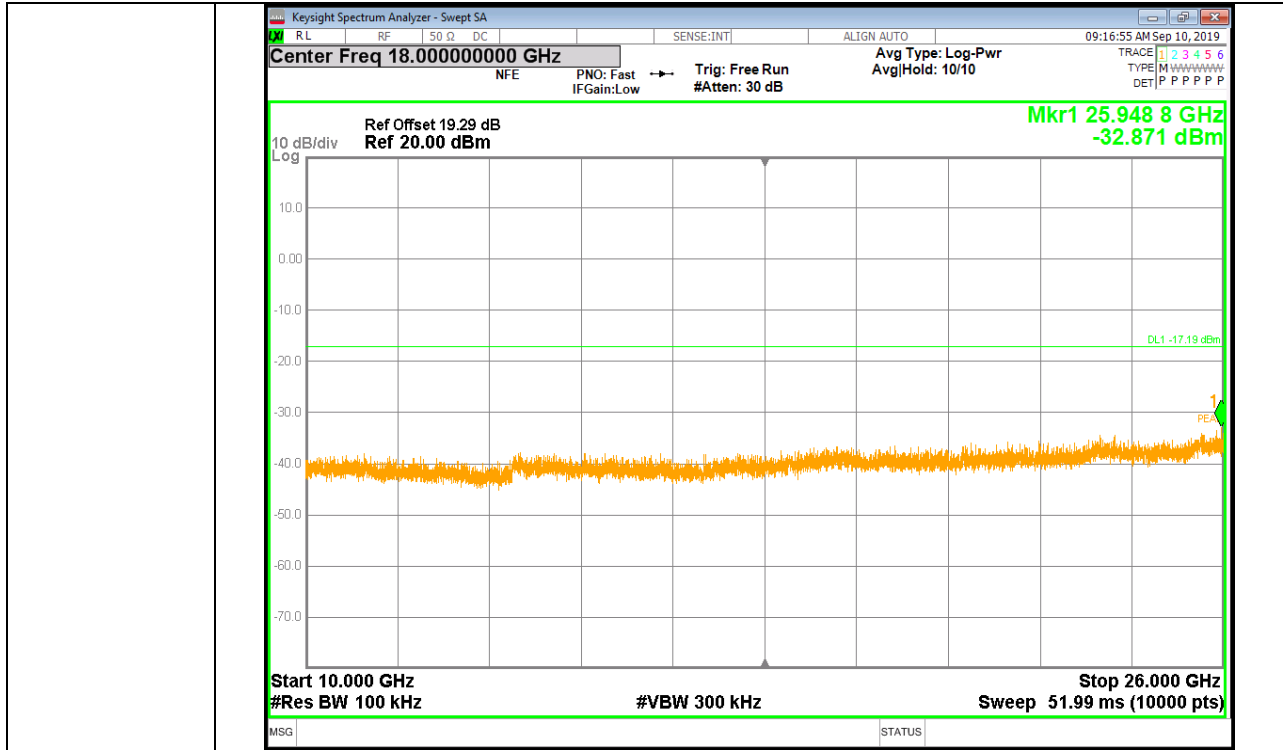

Pref/11g/MCH



Puw/11g/MCH

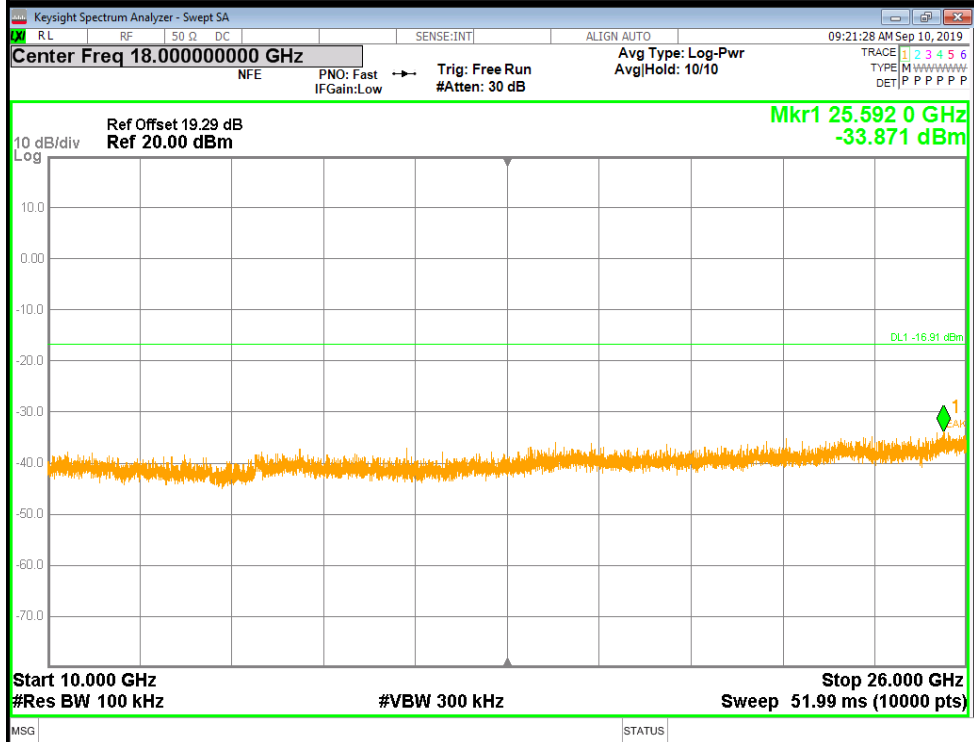
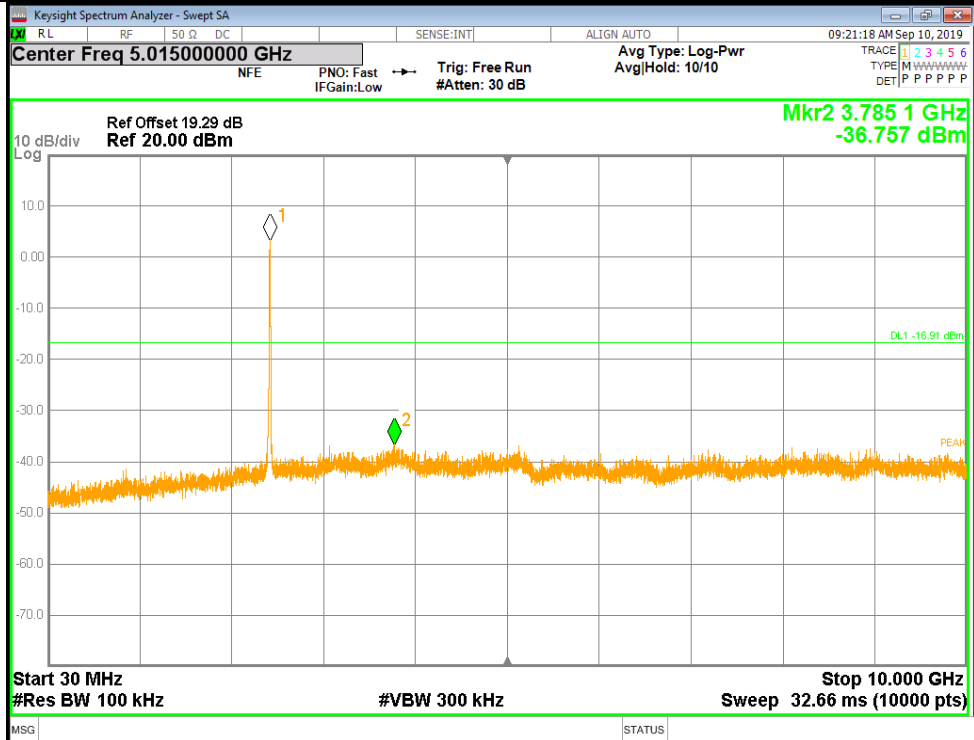

11g_HCH_Graphs

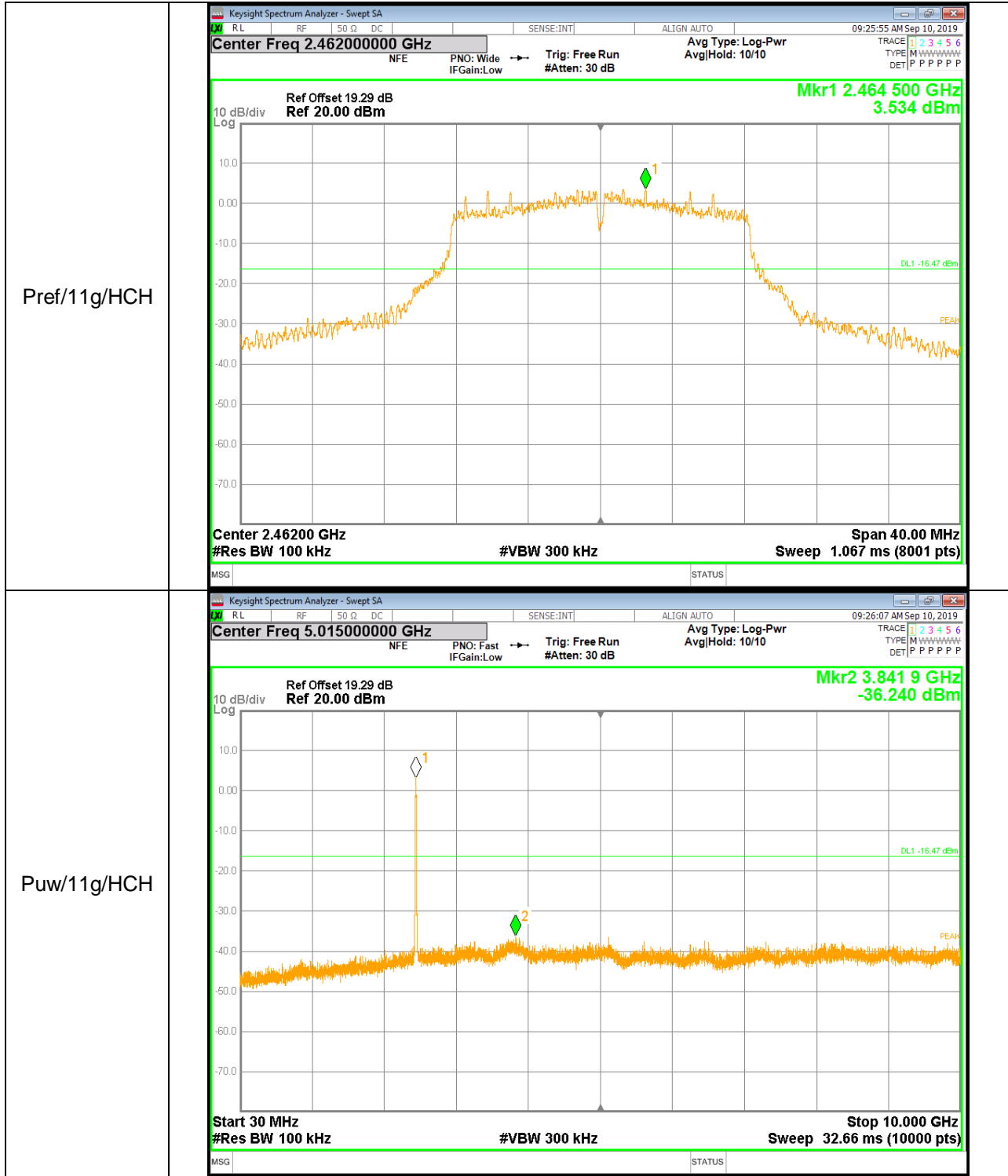

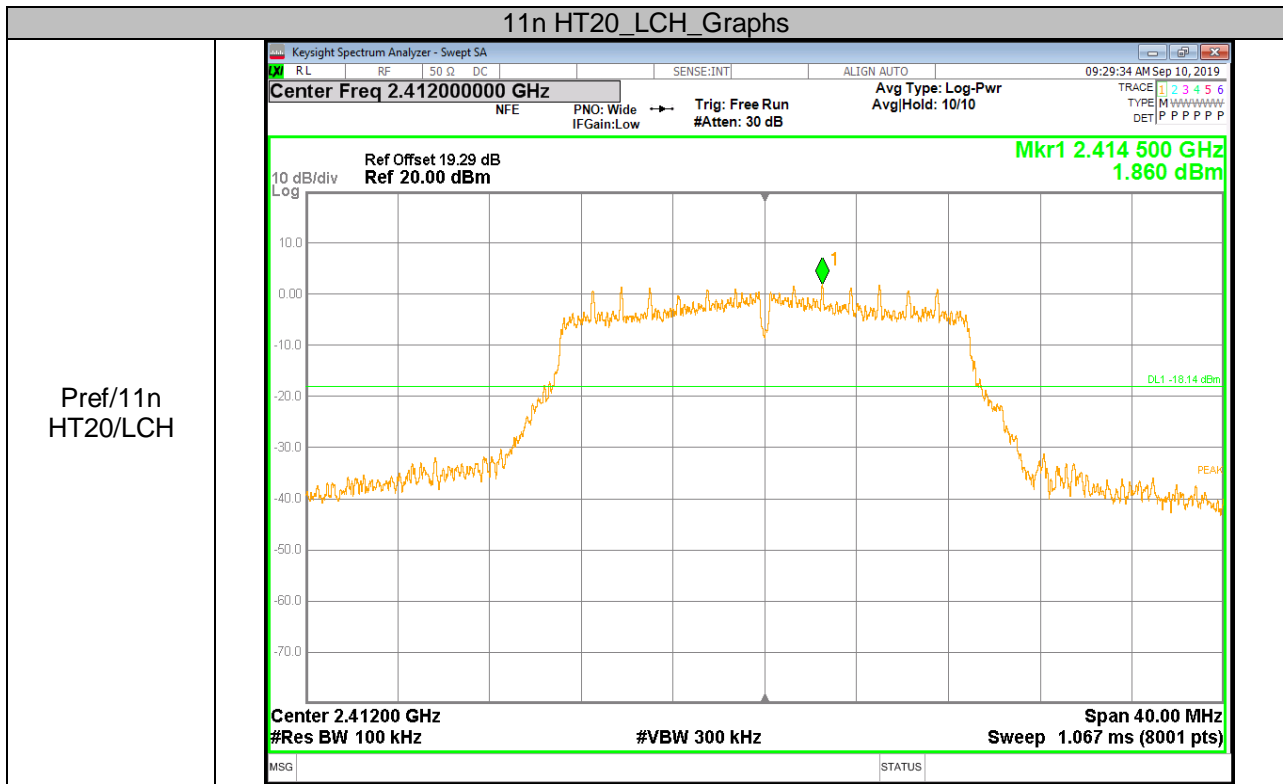
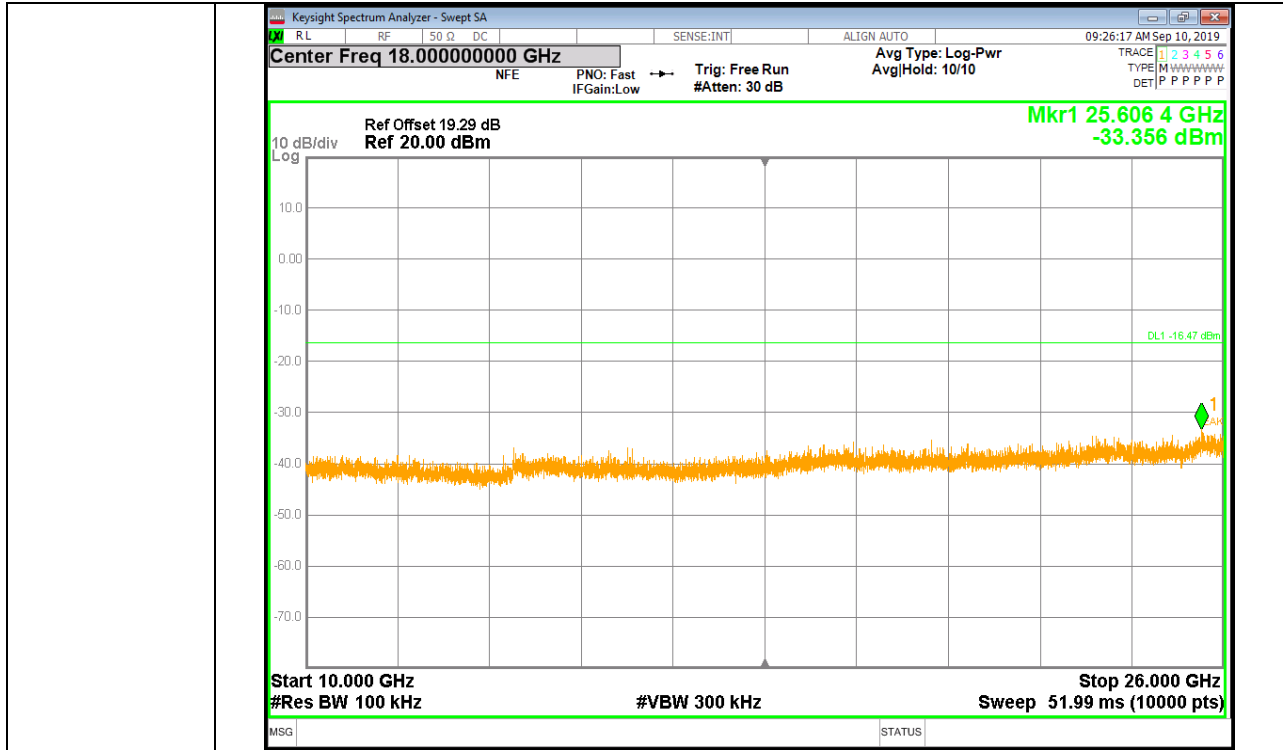

Pref/11n
HT20/LCH



P_w/11n
HT20/MCH

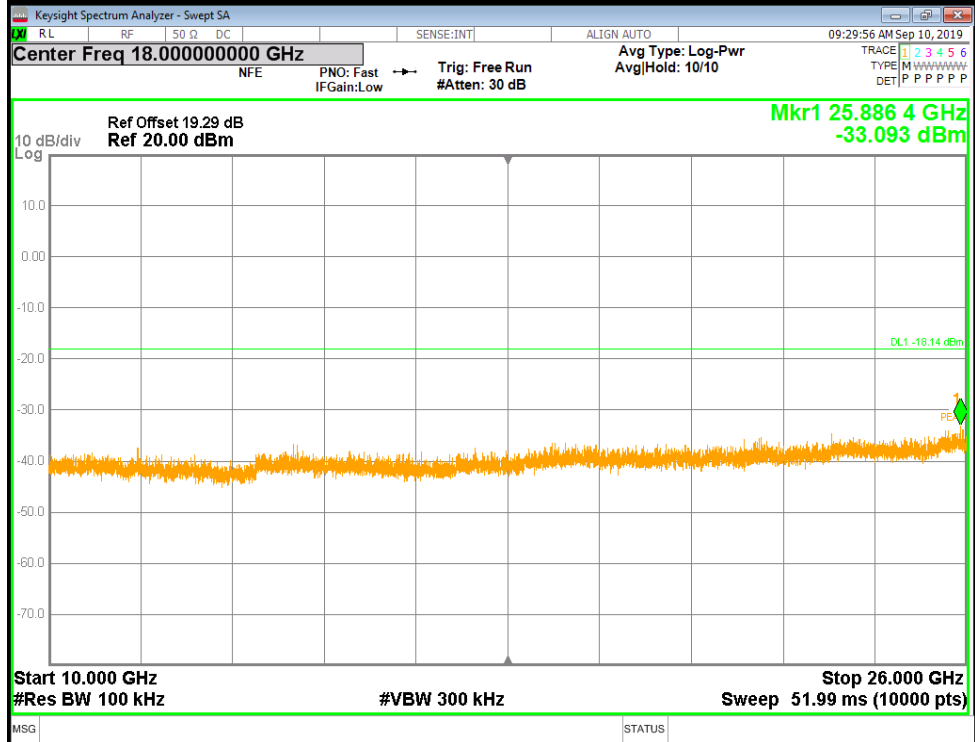
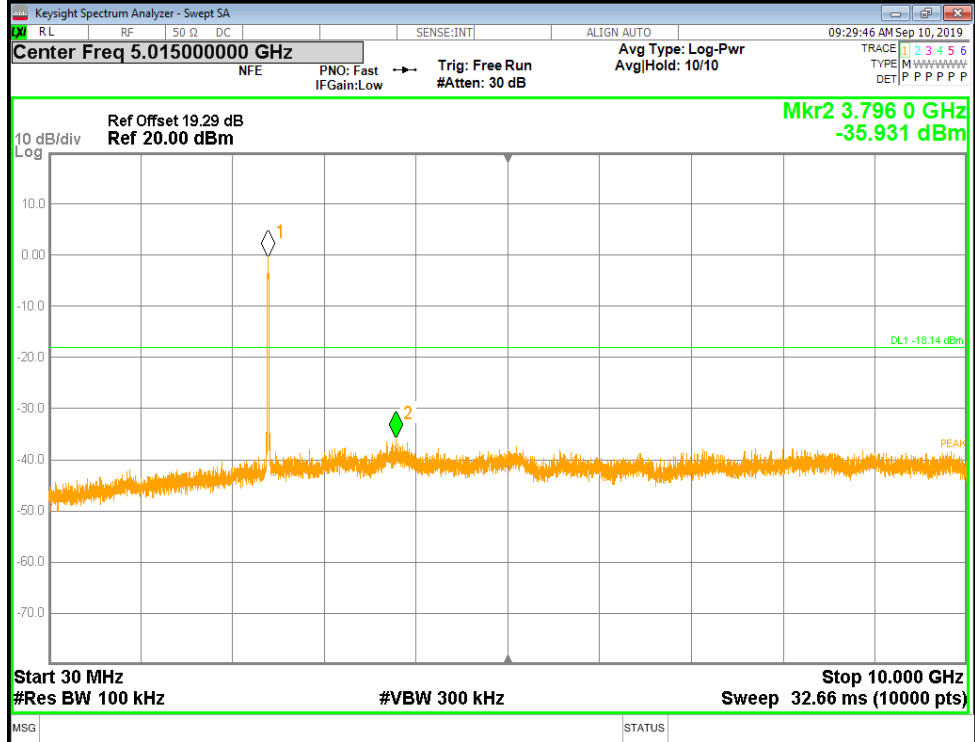

11n HT20_MCH_Graphs



Pref/11n
HT20/MCH

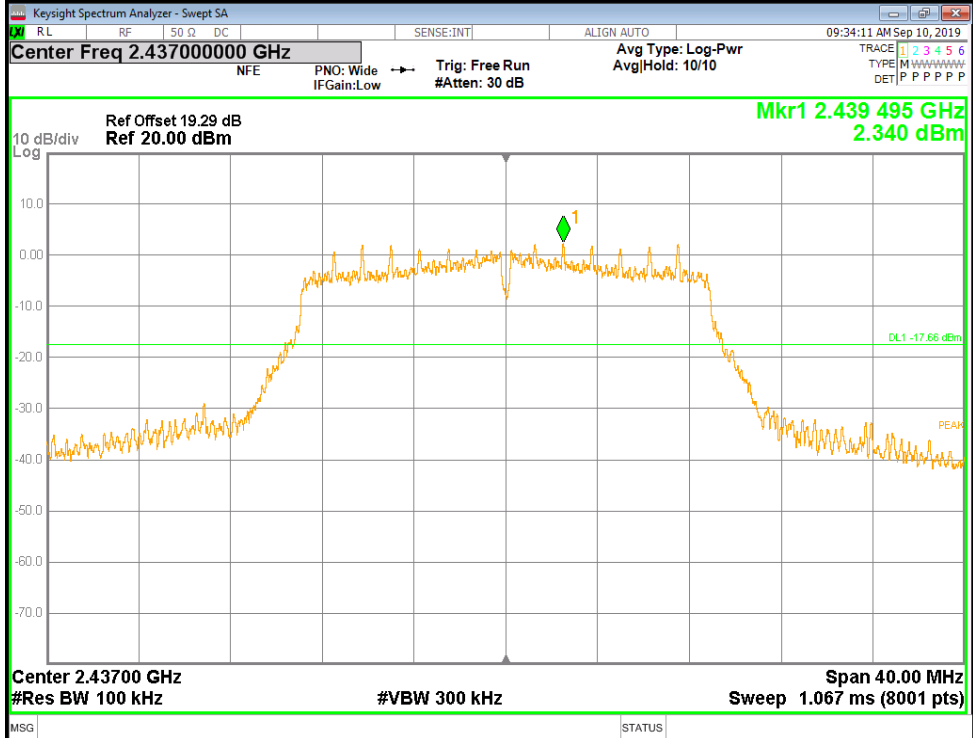

Puw/11n
HT20/MCH

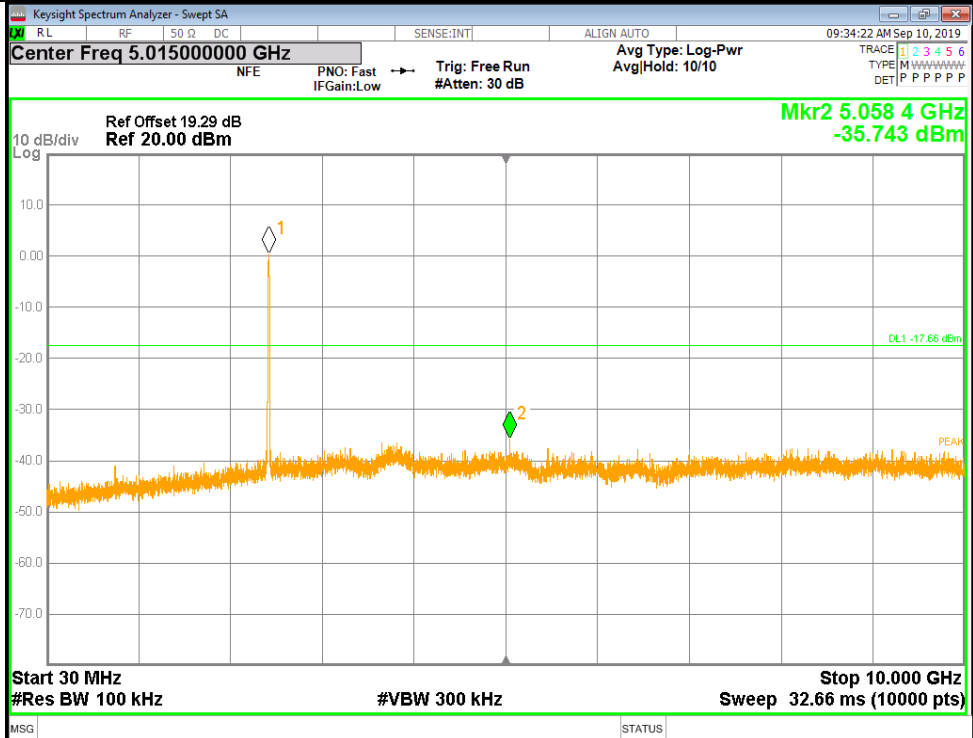

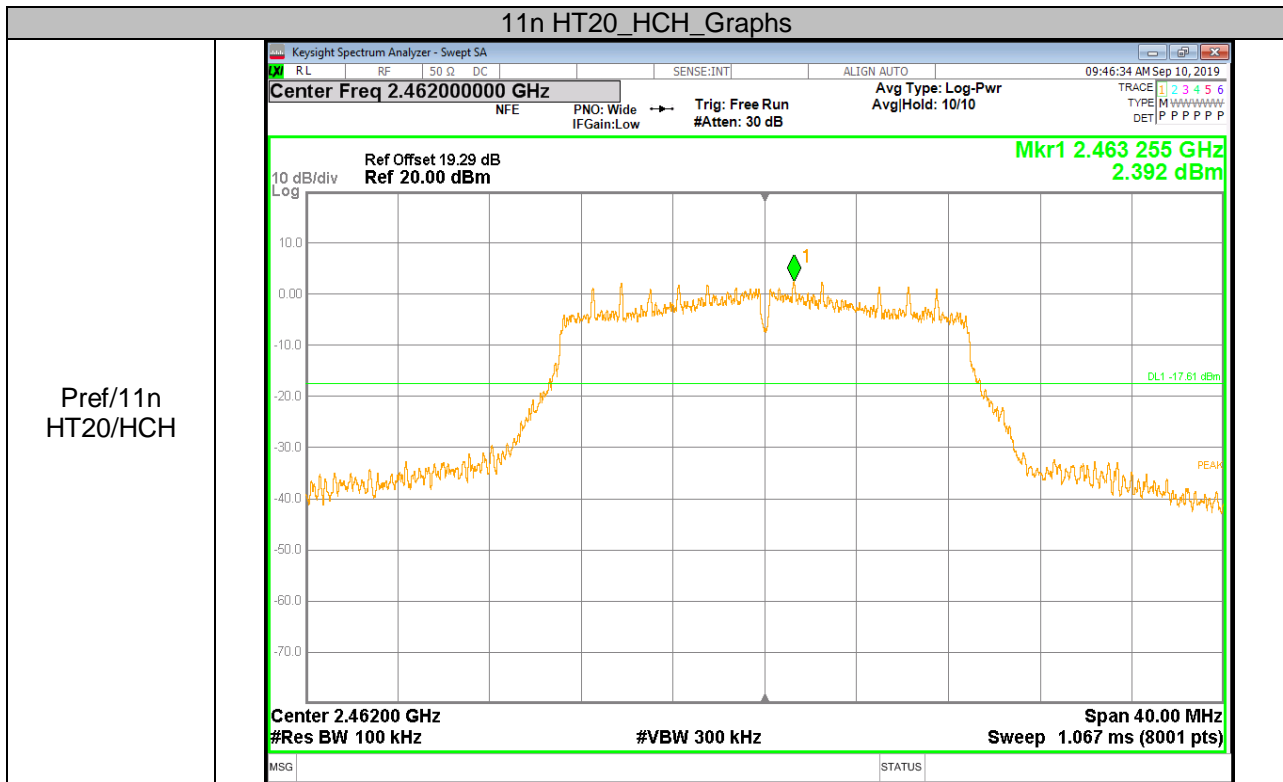
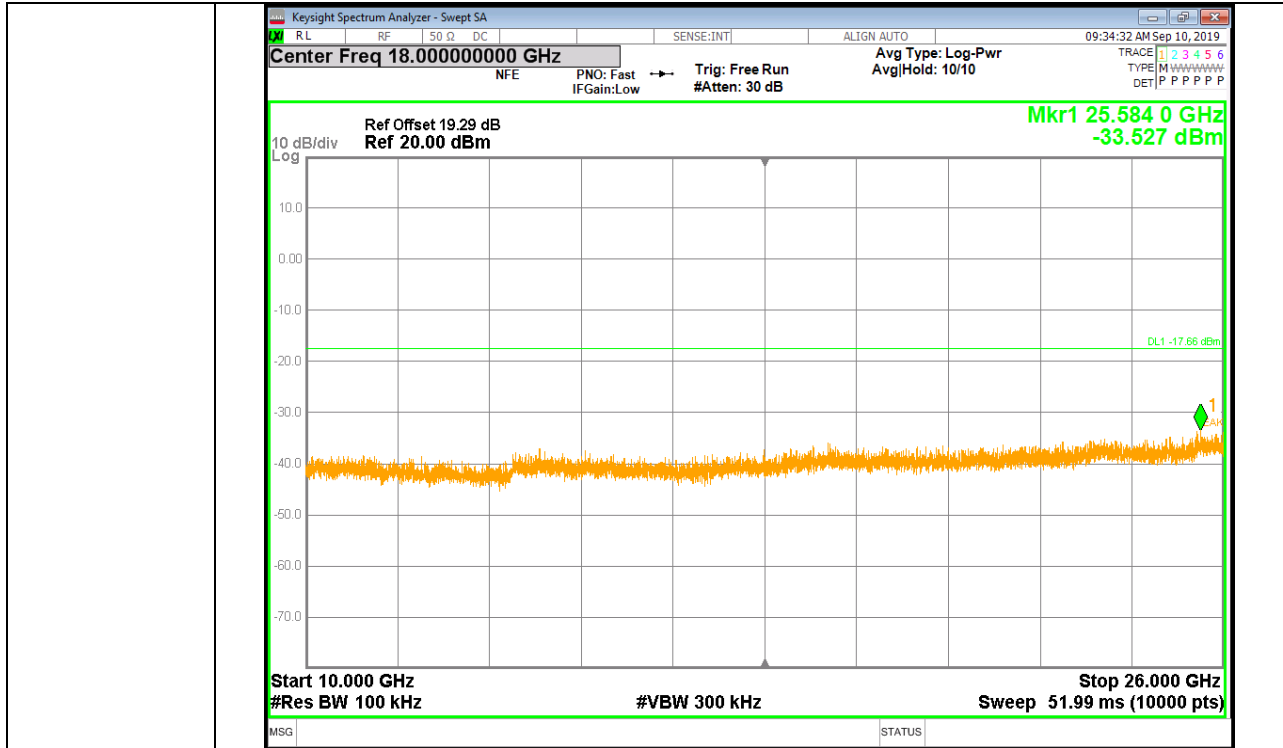



P_w/11n
HT20/HCH

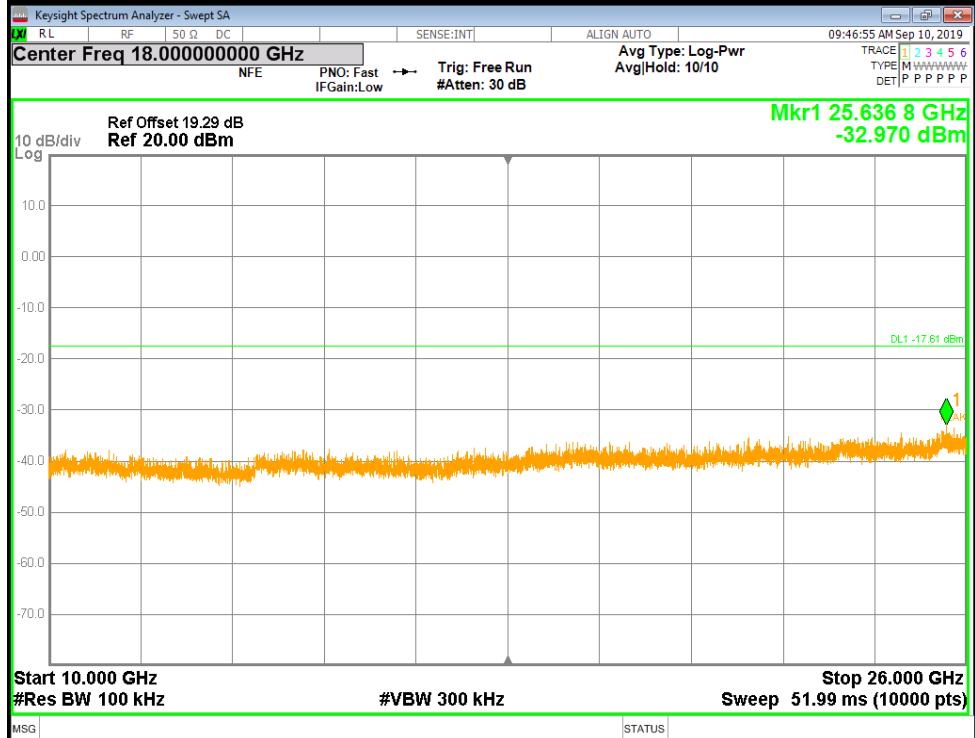
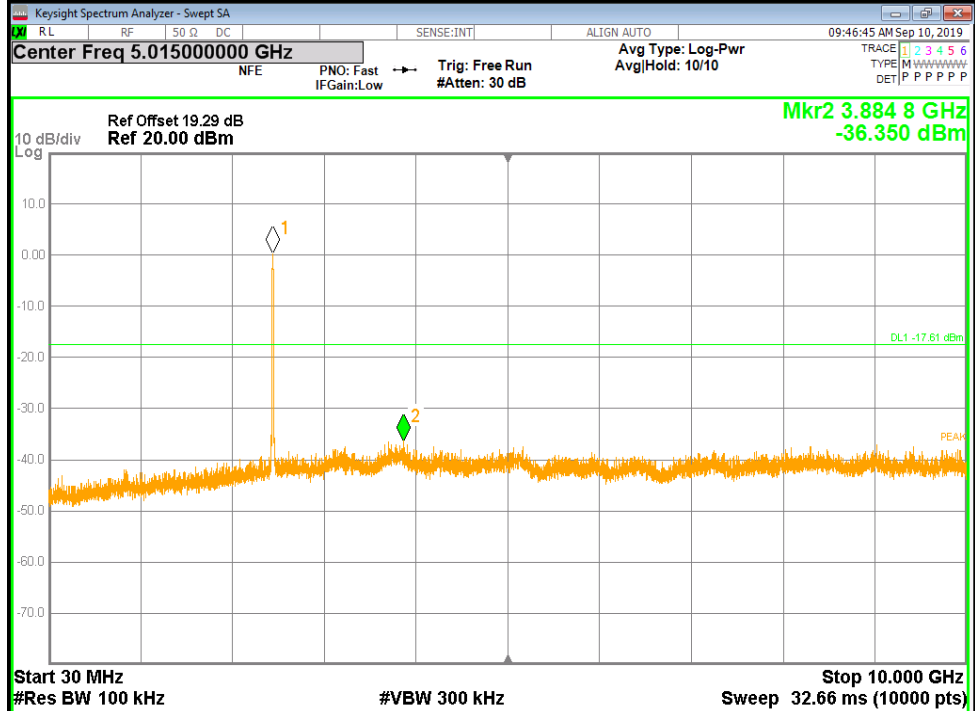



Appendix G): Maximum Power Spectral Density

Result Table

Mode	Channel	Meas.Level [dBm]	Verdict
11b	LCH	-6.174	PASS
11b	MCH	-4.533	PASS
11b	HCH	-5.186	PASS
11g	LCH	-8.628	PASS
11g	MCH	-8.092	PASS
11g	HCH	-7.592	PASS
11n HT20	LCH	-10.594	PASS
11n HT20	MCH	-10.050	PASS
11n HT20	HCH	-10.211	PASS

Test Graph

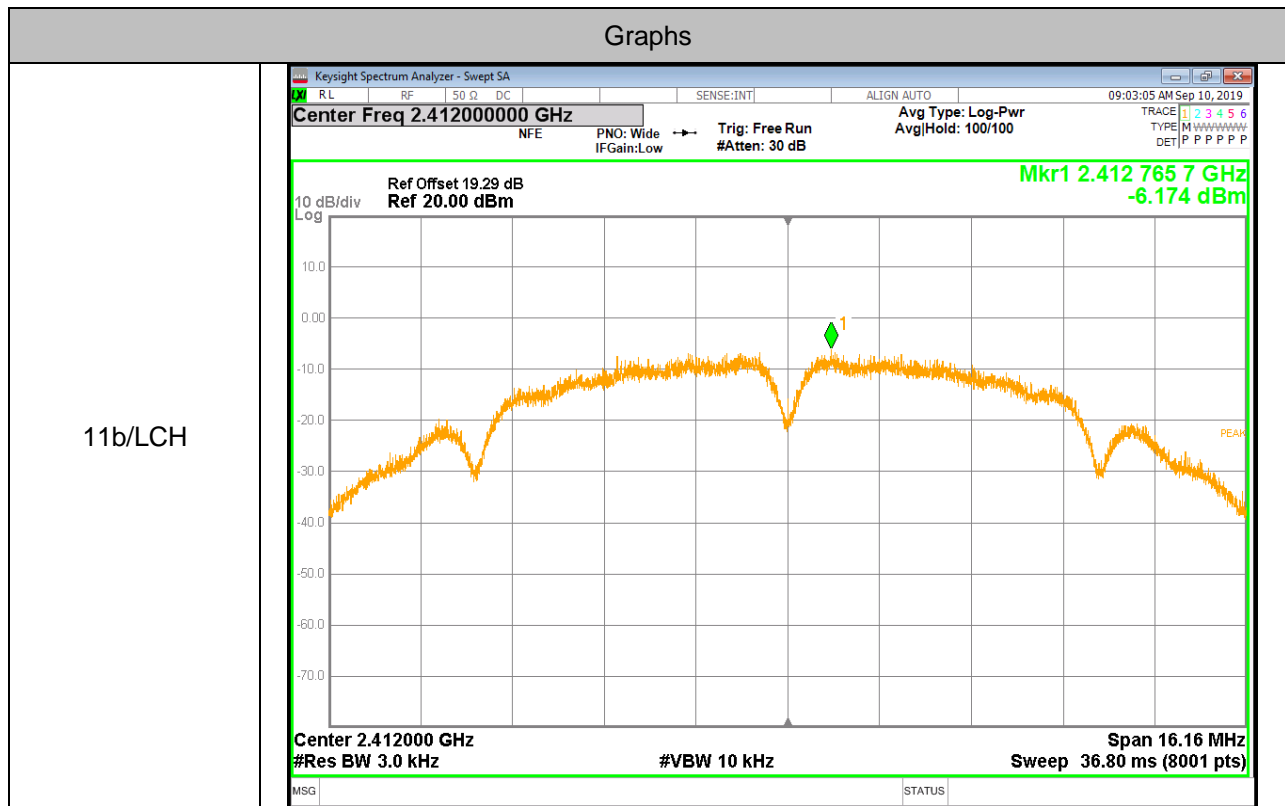

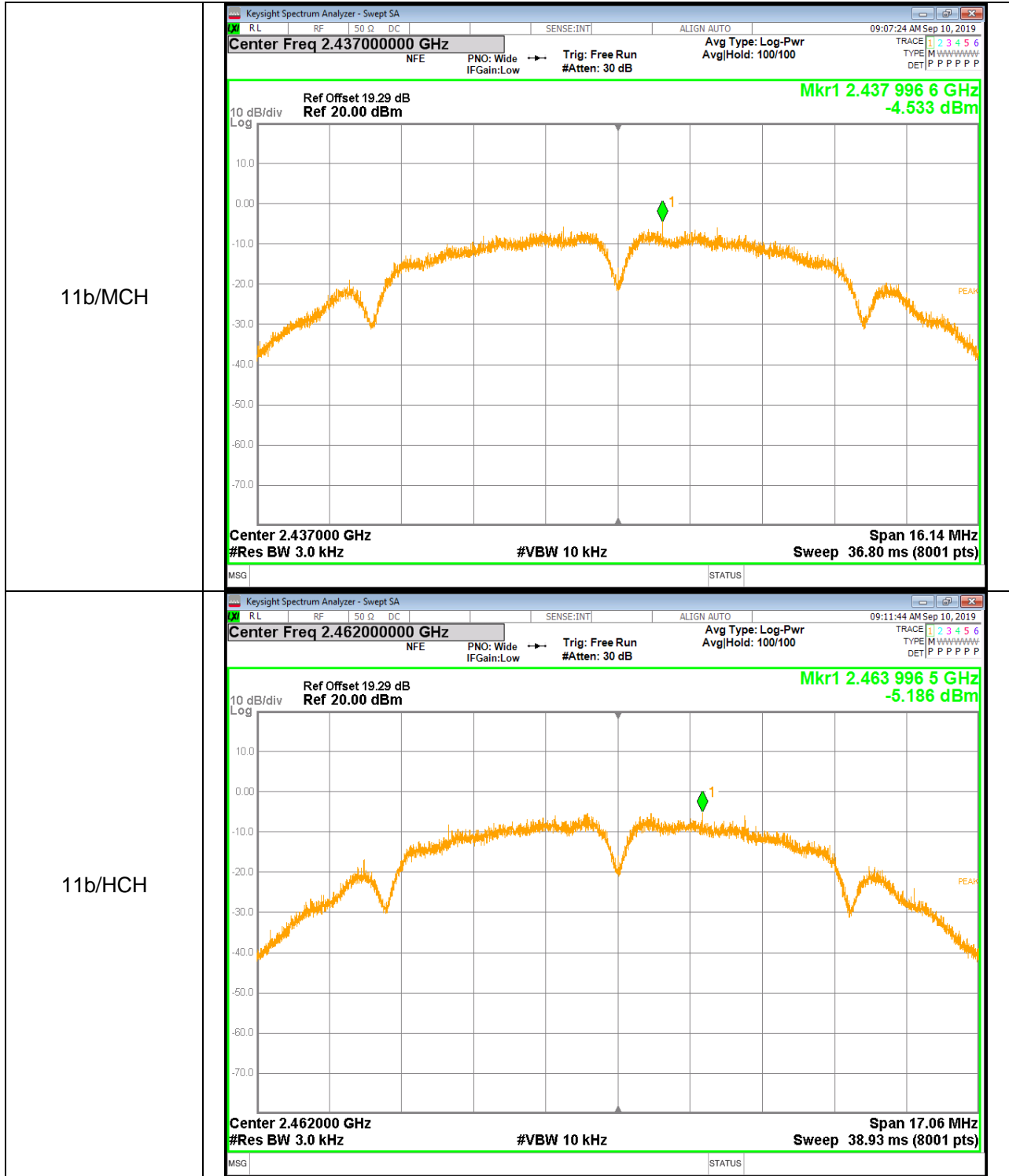

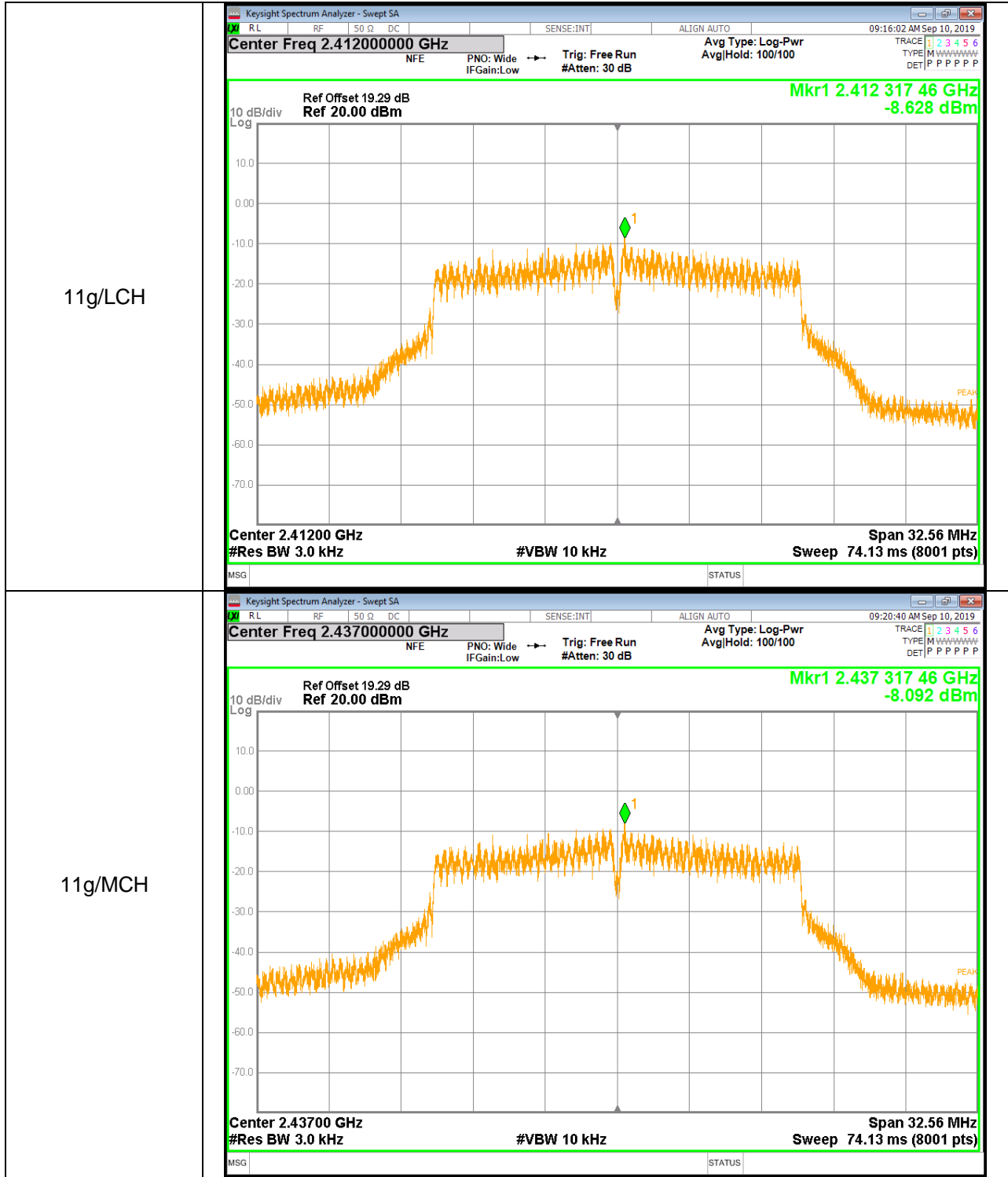

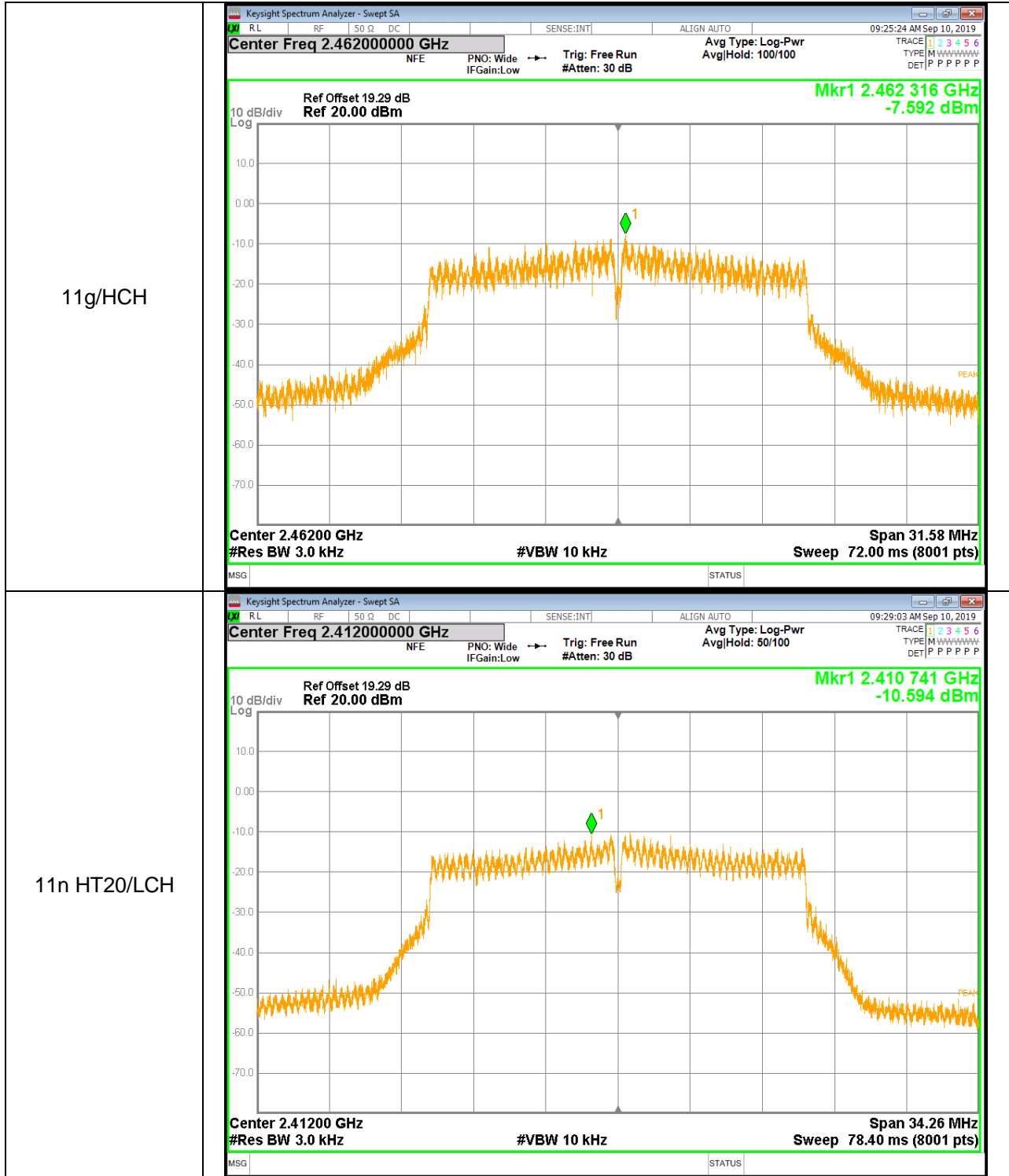

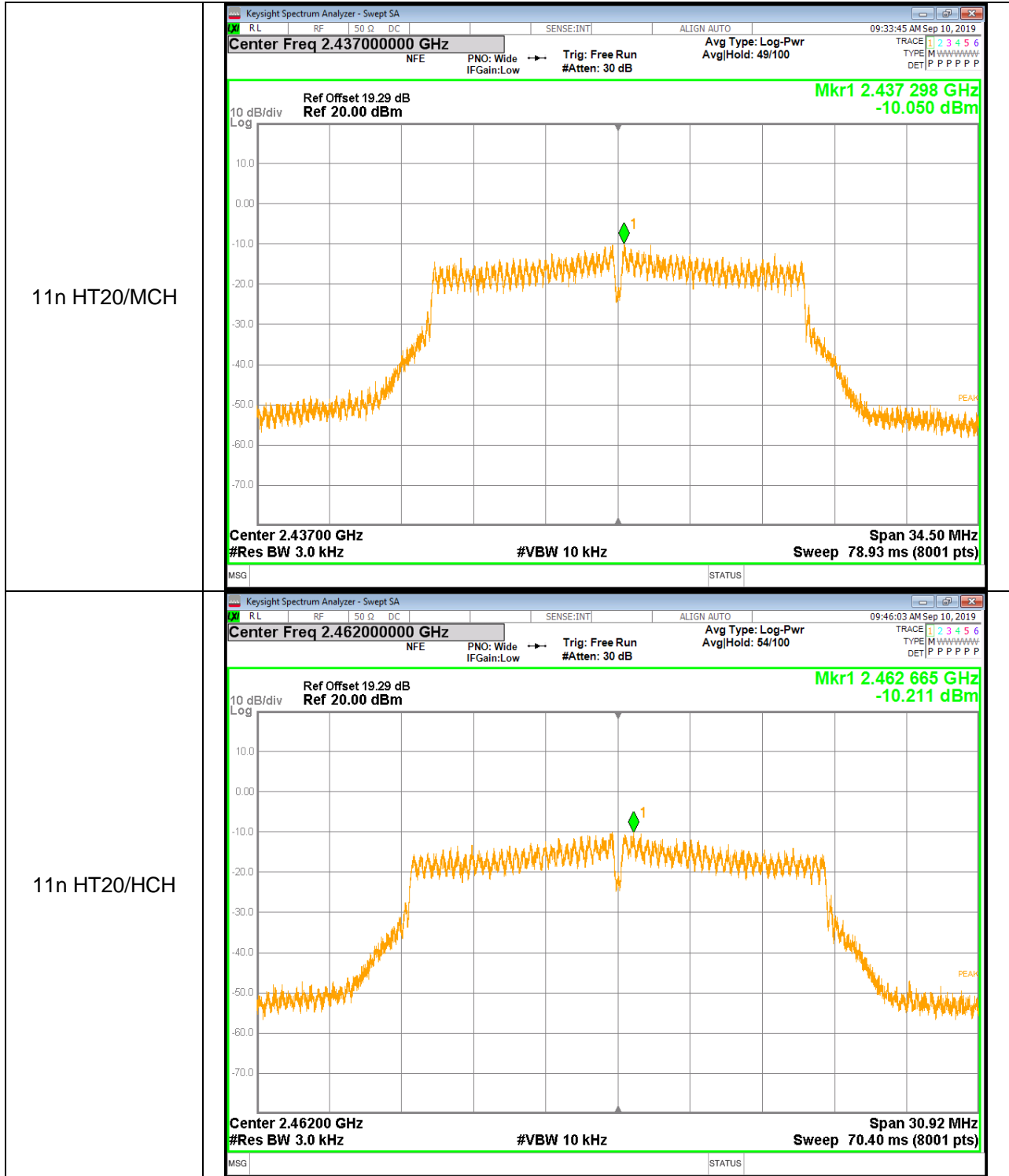

END OF REPORT