



## Certification Test Report

**FCC ID: 2ADCB-BRM1  
IC: 6715C-BRM1**

**FCC Rule Part: 15.247  
ISED Canada Radio Standards Specification: RSS-247**

**Report Number: AT72133675.1P2**

**Manufacturer: Acuity Brands Lighting  
Model: BRM1-3**

**Test Begin Date: January 3, 2018  
Test End Date: January 12, 2018**

**Report Issue Date: April 18, 2018**



FOR THE SCOPE OF ACCREDITATION UNDER Certificate Number: AT-2021

This report must not be used by the client to claim product certification, approval, or endorsement by ANAB, NIST, or any agency of the Federal Government.

**Prepared by:**

**Ryan McGann  
Senior Engineer  
TUV SUD America Inc.**

**Reviewed by:**

**Steve O'Steen  
Service Line Manager, EMC  
TUV SUD America Inc.**

This test report shall not be reproduced except in full. This report may be reproduced in part with prior written consent of TUV SUD America Inc. The results contained in this report are representative of the sample(s) submitted for evaluation.

**This report contains 17 pages**

# TABLE OF CONTENTS

<b>1</b>	<b>GENERAL .....</b>	<b>3</b>
1.1	PURPOSE.....	3
1.2	PRODUCT DESCRIPTION.....	3
1.3	TEST METHODOLOGY AND CONSIDERATIONS .....	4
<b>2</b>	<b>TEST FACILITIES.....</b>	<b>5</b>
2.1	LOCATION .....	5
2.2	LABORATORY ACCREDITATIONS/RECOGNITIONS/CERTIFICATIONS .....	5
2.3	RADIATED EMISSIONS TEST SITE DESCRIPTION .....	6
2.3.1	<i>Semi-Anechoic Chamber Test Site</i> .....	6
2.3.2	<i>Open Area Tests Site (OATS)</i> .....	7
2.4	CONDUCTED EMISSIONS TEST SITE DESCRIPTION .....	8
<b>3</b>	<b>APPLICABLE STANDARD REFERENCES.....</b>	<b>8</b>
<b>4</b>	<b>LIST OF TEST EQUIPMENT.....</b>	<b>9</b>
<b>5</b>	<b>SUPPORT EQUIPMENT.....</b>	<b>10</b>
<b>6</b>	<b>EQUIPMENT UNDER TEST SETUP BLOCK DIAGRAM .....</b>	<b>11</b>
<b>7</b>	<b>SUMMARY OF TESTS.....</b>	<b>12</b>
7.1	ANTENNA REQUIREMENT – FCC: SECTION 15.203 .....	12
7.2	POWER LINE CONDUCTED EMISSIONS – FCC: SECTION 15.207; ISED CANADA: RSS-GEN 8.8.....	12
7.2.1	<i>Measurement Procedure</i> .....	12
7.2.2	<i>Measurement Results</i> .....	12
7.3	EMISSION LEVELS .....	15
7.3.1	<i>Emissions into Restricted Frequency Bands – FCC: Section 15.205, 15.209; ISED Canada: RSS-Gen 8.9 / 8.10</i> .....	15
7.3.1.1	Measurement Procedure .....	15
7.3.1.2	Duty Cycle Correction .....	15
7.3.1.3	Measurement Results .....	15
7.3.1.4	Sample Calculation: .....	16
<b>8</b>	<b>ESTIMATION OF MEASUREMENT UNCERTAINTY .....</b>	<b>17</b>
<b>9</b>	<b>CONCLUSION.....</b>	<b>17</b>

## 1 GENERAL

### 1.1 Purpose

The purpose of this report is to demonstrate compliance with Part 15 Subpart C of the FCC's Code of Federal Regulations and Innovation, Science, and Economic Development Canada's Radio Standards Specification RSS-247 Certification for Class II Permissive Change approval.

The purpose of this Class II Permissive Change is to address the addition of a new model BRM1-3 to the previous family certification. This new model BRM1-3 includes a new antenna assembly with the same internal chip antenna previously certified. The BRM1-1 has component designators C12 and L4 that were previously not populated, now containing a 0.5pF capacitor and 2.2nH inductor respectively. Additionally, component designator R7 on the BRM1-1 is a 0Ω resistor, replaced with a 2pF capacitor on the BRM1-3. RF conducted characteristics are not affected due to the components on the chip antenna assembly.

### 1.2 Product Description

Acuity Brands BRM1 module provides indoor geo-location information via Bluetooth LE. The module serves as a single beacon to provide 1-way communication with a user's device to define their physical location. Also this device can adjust brightness of an external LED driver. This distance is calculated based upon receive signal strength intensity (RSSI) between the beacon and mobile device. The beacon broadcasts its identification every 154ms using a standard 30-byte packet under normal operating condition.

#### Technical Information:

Detail	Description
Frequency Range	2402 - 2480 MHz
Number of Channels	40
Modulation Format	GFSK
Data Rates	1 MBPS
Operating Voltage	2.8 Vdc – 6.5 Vdc (5Vdc Nominal)
Antenna Type / Gain	Internal Chip Antenna: 0.5 dBi Printed Inverted F Antenna: 2.0 dBi

#### Manufacturer Information:

Acuity Brands Lighting, Inc.  
One Lithonia Way  
Conyers, GA 30012

Test Sample Serial Number: Radiated Emissions: 1740-15C  
Power Line Conducted Emissions: 1740-16C

Test Sample Condition: The test samples were provided in good working order with no visible defects.

### **1.3 Test Methodology and Considerations**

All modes of operation, including all data rates, were evaluated and the data presented in this report represents the worst case where applicable. The EUT was configured to generate a 62% duty cycle pulse for testing due to the firmware restrictions from the chip manufacturer.

For radiated emissions, the EUT was evaluated in three orthogonal orientations. The worst-case orientation was X-orientation. The EUT was powered via a USB cable to a laptop to facilitate the test modes. See test setup photos and Theory of Operation for more information.

For AC power line conducted emissions, the EUT was evaluated with a typical host device. The EUT was set to transmit continuously throughout the test.

Power setting during test:                      +4 dBm

**2 TEST FACILITIES****2.1 Location**

The radiated and conducted emissions test sites are located at the following address:

TÜV SÜD America, Inc.  
5015 B.U. Bowman Drive  
Buford, GA 30518  
Phone: (770) 831-8048  
Fax: (770) 831-8598

**2.2 Laboratory Accreditations/Recognitions/Certifications**

TÜV SÜD America, Inc. is accredited to ISO/IEC 17025 by the ANSI-ASQ National Accreditation Board/ANAB accreditation program, and has been issued certificate number AT-2021 in recognition of this accreditation. Unless otherwise specified, all tests methods described within this report are covered under the ISO/IEC 17025 scope of accreditation.

The Semi-Anechoic Chamber Test Site, Open Area Test Site (OATS) and Conducted Emissions Site have been fully described, submitted to, and accepted by the FCC, ISED Canada and the Japanese Voluntary Control Council for Interference by information technology equipment.

FCC Registration Number: 391271

ISED Canada Lab Code: IC 23597

VCCI Member Number: 1831

- VCCI OATS Registration Number R-1526
- VCCI Conducted Emissions Site Registration Number: C-1608

## 2.3 Radiated Emissions Test Site Description

### 2.3.1 Semi-Anechoic Chamber Test Site

The Semi-Anechoic Chamber Test Site consists of a 20' x 30' x 18' shielded enclosure. The chamber is lined with Toyo Ferrite Grid Absorber, model number FFG-1000. The ferrite tile grid is 101 x 101 x 19mm thick and weighs approximately 550 grams. These tiles are mounted on steel panels and installed directly on the inner walls of the chamber.

The turntable is 150cm in diameter and is located 160cm from the back wall of the chamber. The chamber is grounded via 1 - 8' copper ground rod, installed at the center of the back wall, it is bound to the ground plane using 3/4" stainless steel braided cable.

The turntable is all steel, flush mounted table installed in an all steel frame. The table is remotely operated from inside the control room located 25' from the range. The turntable is electrically bonded to the surrounding ground plane via steel fingers installed on the edge of the turn table. The steel fingers make constant contact with the ground plane during operation.

Behind the turntable is a 3' x 6' x 4' deep shielded pit used for support equipment if necessary. The pit is equipped with 1 - 4" PVC chases from the turntable to the pit that allow for cabling to the EUT if necessary. The underside of the turntable can be accessed from the pit so cables can be supplied to the EUT from the pit.

A diagram of the Semi-Anechoic Chamber Test Site is shown in Figure 2.3-1 below:

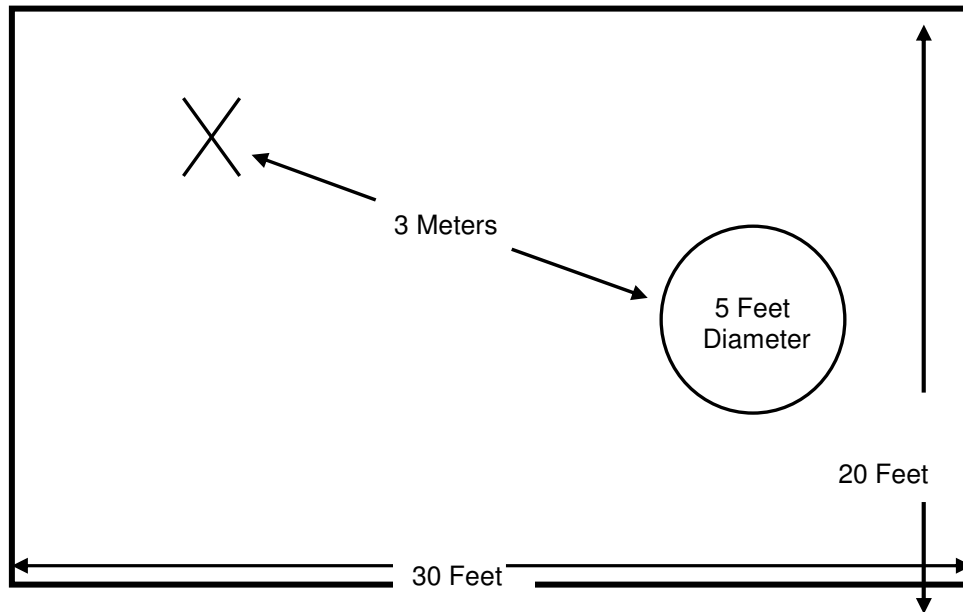

Figure 2.3-1: Semi-Anechoic Chamber Test Site

**2.3.2 Open Area Tests Site (OATS)**

The open area test site consists of a 40' x 66' concrete pad covered with a perforated electro-plated galvanized sheet metal. The perforations in the sheet metal are 1/8" holes that are staggered every 3/16". The individual sheets are placed to overlap each other by 1/4" and are riveted together to provide a continuous seam. Rivets are spaced every 3" in a 3 x 20 meter perimeter around the antenna mast and EUT area. Rivets in the remaining area are spaced as necessary to properly secure the ground plane and maintain the electrical continuity.

The entire ground plane extends 12' beyond the turntable edge and 16' beyond the antenna mast when set to a 10 meter measurement distance. The ground plane is grounded via 4 - 8' copper ground rods, each installed at a corner of the ground plane and bound to the ground plane using 3/4" stainless steel braided cable.

The turntable is an all aluminum 10' flush mounted table installed in an all aluminum frame. The table is remotely operated from inside the control room located 40' from the range. The turntable is electrically bonded to the surrounding ground plane via steel fingers installed on the edge of the turn table. The steel fingers make constant contact with the ground plane during operation.

Adjacent to the turntable is a 7' x 7' square and 4' deep concrete pit used for support equipment if necessary. The pit is equipped with 5 - 4" PVC chases from the pit to the control room that allow for cabling to the EUT if necessary. The underside of the turntable can be accessed from the pit so cables can be supplied to the EUT from the pit. The pit is covered with 2 sheets of 1/4" diamond style re-enforced steel sheets. The sheets are painted to match the perforated steel ground plane; however the underside edges have been masked off to maintain the electrical continuity of the ground plane. All reflecting objects are located outside of the ellipse defined in ANSI C63.10.

A diagram of the Open Area Test Site is shown in Figure 2.3-2 below:

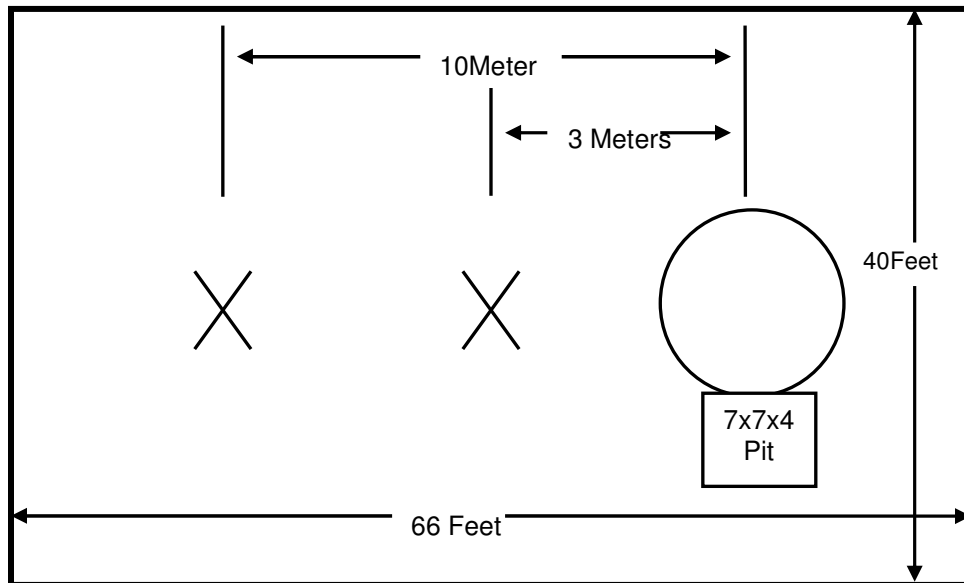

**Figure 2.3-2: Open Area Test Site**

## 2.4 Conducted Emissions Test Site Description

The AC mains conducted EMI site is located in the main EMC lab. It consists of an 8' x 12' solid aluminum horizontal ground reference plane (GRP) bonded every 3" to an 8' X 12' vertical ground plane.

The site is of sufficient size to test table top and floor standing equipment in accordance with ANSI C63.10.

A diagram of the room is shown below in figure 2.4-1:

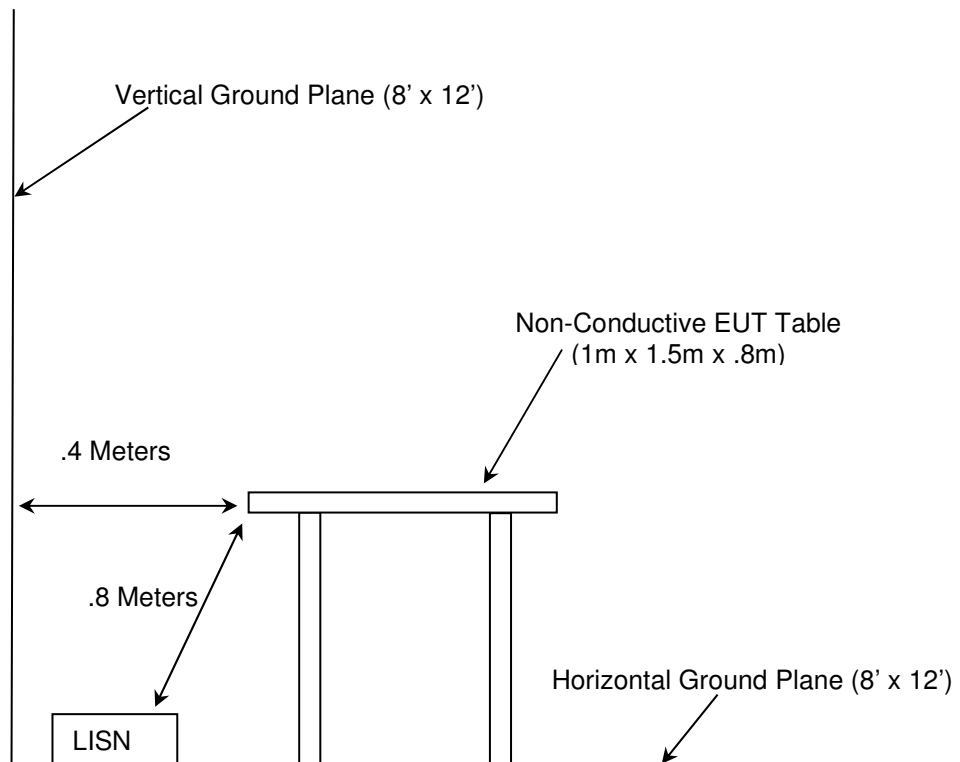

Figure 2.4-1: AC Mains Conducted EMI Site

## 3 APPLICABLE STANDARD REFERENCES

The following standards were used:

- ❖ ANSI C63.10-2013: American National Standard of Procedures for Compliance Testing of Unlicensed Wireless Devices.
- ❖ US Code of Federal Regulations (CFR): Title 47, Part 2, Subpart J: Equipment Authorization Procedures, 2018
- ❖ US Code of Federal Regulations (CFR): Title 47, Part 15, Subpart C: Radio Frequency Devices, Intentional Radiators, 2018
- ❖ FCC KDB 558074 D01 DTS Meas Guidance v04 - Guidance for Performing Compliance Measurements on Digital Transmission Systems (DTS) Operating Under §15.247, April 5, 2017
- ❖ ISED Canada Radio Standards Specification: RSS-247 – Digital Transmission Systems (DTSs), Frequency Hopping Systems (FHSs) and Licence-Exempt Local Area Network (LE-LAN) Devices, Issue 2, Feb 2017.
- ❖ ISED Canada Radio Standards Specification: RSS-GEN – General Requirements for Compliance of Radio Apparatus, Issue 4, Nov 2014.



#### 4 LIST OF TEST EQUIPMENT

The calibration interval of test equipment is annually or the manufacturer's recommendations. Where the calibration interval deviates from the annual cycle based on the instrument manufacturer's recommendations, it shall be stated below.

**Table 4-1: Test Equipment**

Asset ID	Manufacturer	Model #	Equipment Type	Serial #	Last Calibration Date	Calibration Due Date
30	Spectrum Technologies	DRH-0118	Antennas	970102	5/9/2017	5/9/2019
40	EMCO	3104	Antennas	3211	6/8/2016	6/8/2018
73	Agilent	8447D	Amplifiers	2727A05624	7/24/2017	7/24/2018
167	ACS	Chamber EMI Cable Set	Cable Set	167	9/29/2017	9/29/2018
334	Rohde&Schwarz	3160-09	Antennas	49404	11/4/2010	NCR
335	Suhner	SF-102A	Cables	882/2A	7/11/2017	7/11/2018
338	Hewlett Packard	8449B	Amplifiers	3008A01111	7/11/2017	7/11/2019
345	Suhner Sucoflex	102A	Cables	1077/2A	7/10/2017	7/10/2018
412	Electro Metrics	LPA-25	Antennas	1241	8/8/2016	8/8/2018
422	Florida RF	SMS-200AW-72.0-SMR	Cables	805	11/27/2017	11/27/2018
616	Florida RF Cables	SMRE-200W-12.0-SMRE	Cables	N/A	10/7/2017	10/7/2018
622	Rohde & Schwarz	FSV40	Analyzers	101338	7/15/2016	7/15/2018
676	Florida RF Labs	SMS-290AW-480.0-SMS	Cables	MFR2Y194	12/02/2017	12/02/2018

**NCR = No Calibration Required**

**NOTE: All test equipment was used only during active calibration cycles.**

## 5 SUPPORT EQUIPMENT

Table 5-1: Support Equipment – Radiated Emissions

Item	Equipment Type	Manufacturer	Model/Part Number	Serial Number
1	Laptop Computer	Dell	Latitude E5450	N/A
2	Laptop Power Supply	Dell	LA65NM130	N/A
3	LED Driver	Acuity Brands	SL265U	0217170027BMPF
4	LED Light Board	Acuity Brands	401-00579-001	8487

Table 5-2: Cable Description – Radiated Emissions

Cable	Cable Type	Length	Shield	Termination
A	USB Cable	1100 cm	No	EUT to Laptop Computer
B	DC Power Cable	200 cm	No	Laptop Computer to Laptop Power Supply
C	AC Power Cable	150 cm	No	Laptop Power Supply to AC Mains
D	DC Power and Communication Cable	15 cm	No	LED Driver to EUT
E	AC Power Cable	200 cm	No	LED Driver to AC Mains
F	DC Power Cable	30 cm	No	LED Driver to LED Light Board

6 EQUIPMENT UNDER TEST SETUP BLOCK DIAGRAM

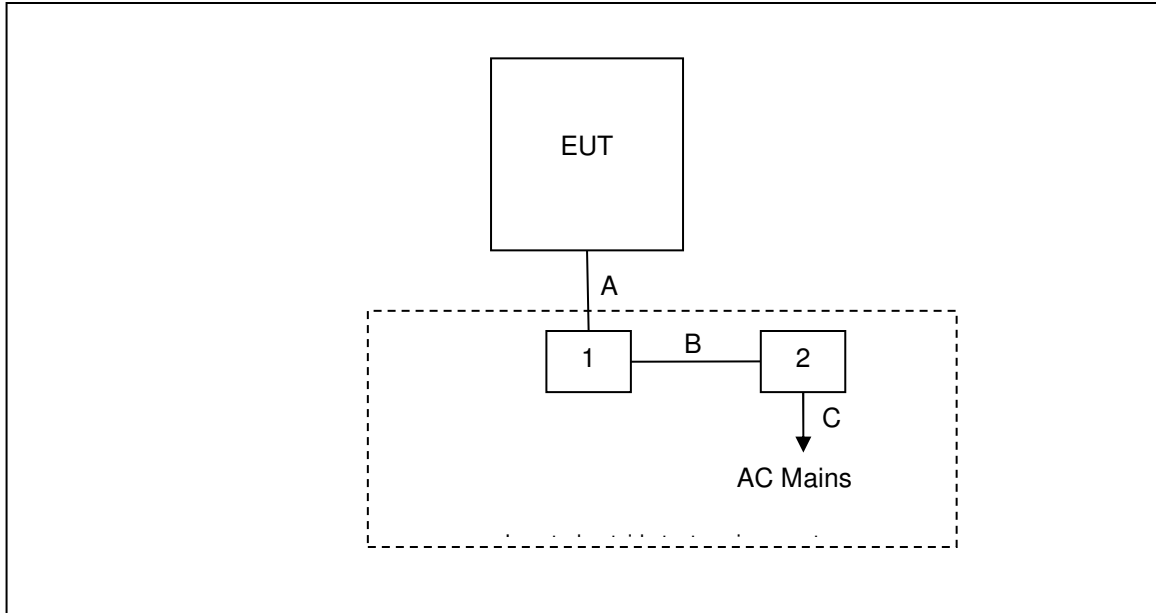

Figure 6-1: Test Setup Block Diagram – Radiated Emissions

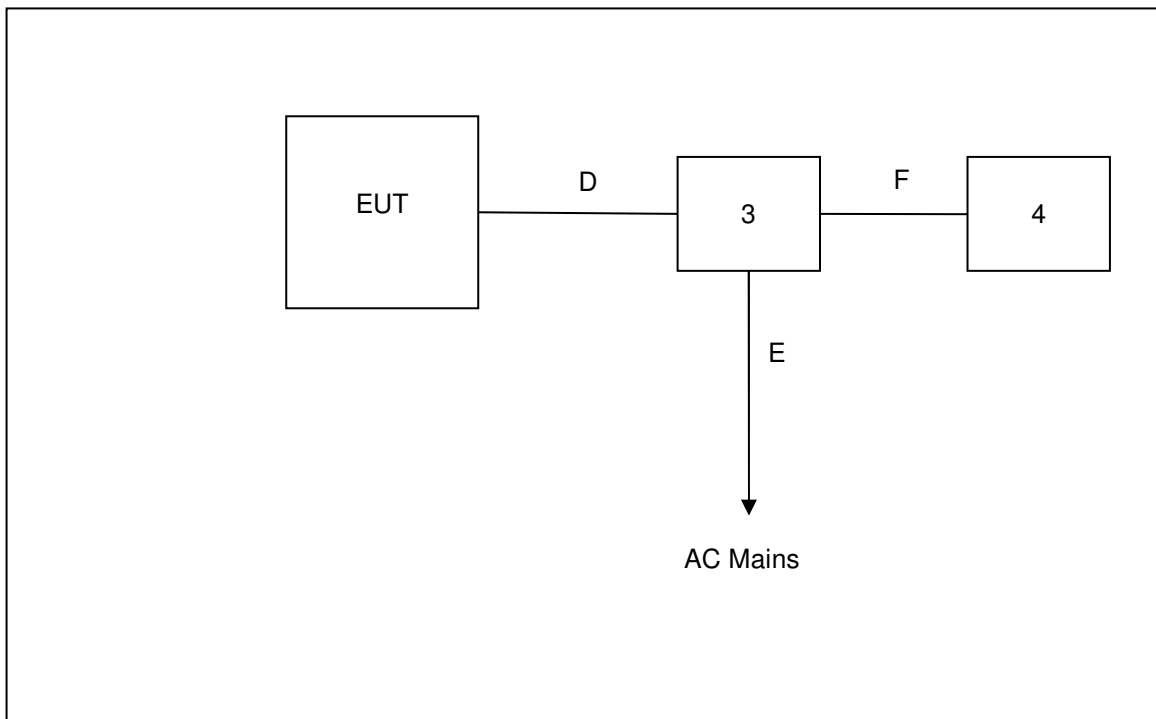

Figure 6-2: Test Setup Block Diagram – Power Line Conducted Emissions

## **7 SUMMARY OF TESTS**

Along with the tabular data shown below, plots were taken of all signals deemed important enough to document.

### **7.1 Antenna Requirement – FCC: Section 15.203**

The internal antenna is a chip antenna, soldered directly to the PCB, and cannot be removed without damage to the EUT, therefore satisfying the requirements of Section 15.203. The gain of the internal antenna is 0.5 dBi.

### **7.2 Power Line Conducted Emissions – FCC: Section 15.207; ISED Canada: RSS-Gen 8.8**

#### **7.2.1 Measurement Procedure**

Conducted emissions were performed from 150 kHz to 30 MHz with the spectrum analyzer's resolution bandwidth set to 9 kHz and the video bandwidth set to 30 kHz. The calculation for the conducted emissions is as follows:

**Corrected Reading = Analyzer Reading + LISN Loss + Cable Loss**

**Margin = Applicable Limit - Corrected Reading**

#### **7.2.2 Measurement Results**

Performed by: Tyler Leeson

Table 7.2.2-1: Conducted EMI Results Line 1 – 120Vac / 60Hz

Frequency (MHz)	Corrected Reading		Limit		Margin		Correction (dB)
	Quasi-Peak (dBuV)	Average (dBuV)	Quasi-Peak (dBuV)	Average (dBuV)	Quasi-Peak (dB)	Average (dB)	
0.15	47.8	28.95	66	56	18.2	27.05	9.59
0.154	45.92	26.25	65.78	55.78	19.86	29.53	9.58
0.166	45.67	22.9	65.16	55.16	19.49	32.26	9.58
0.182	41.08	22.8	64.39	54.39	23.31	31.59	9.58
0.202	39.86	22.71	63.53	53.53	23.67	30.82	9.58
0.222	39.51	22.59	62.74	52.74	23.23	30.15	9.58
0.234	41.08	22.51	62.31	52.31	21.23	29.8	9.58
5.45	36.17	22.52	60	50	23.83	27.48	9.74
23.526	37.39	23.85	60	50	22.61	26.15	9.94
24.806	42.06	25.48	60	50	17.94	24.52	9.98

Table 7.2.2-2: Conducted EMI Results Line 2 – 120Vac / 60Hz

Frequency (MHz)	Corrected Reading		Limit		Margin		Correction (dB)
	Quasi-Peak (dBuV)	Average (dBuV)	Quasi-Peak (dBuV)	Average (dBuV)	Quasi-Peak (dB)	Average (dB)	
0.15	48.39	29.46	66	56	17.61	26.54	9.59
0.154	46.24	26.69	65.78	55.78	19.54	29.09	9.58
0.174	42.82	22.89	64.77	54.77	21.95	31.88	9.58
0.194	40.4	22.76	63.86	53.86	23.46	31.1	9.58
0.206	39.83	22.69	63.37	53.37	23.54	30.68	9.58
0.214	38.98	22.64	63.05	53.05	24.07	30.41	9.58
0.226	39.55	22.56	62.6	52.6	23.05	30.04	9.58
5.406	38.49	22.51	60	50	21.51	27.49	9.74
21.634	38.06	23.8	60	50	21.94	26.2	9.93
23.906	39.45	23.92	60	50	20.55	26.08	10.01

Table 7.2.2-3: Conducted EMI Results Line 1 – 277Vac / 60Hz

Frequency (MHz)	Corrected Reading		Limit		Margin		Correction (dB)
	Quasi-Peak (dBuV)	Average (dBuV)	Quasi-Peak (dBuV)	Average (dBuV)	Quasi-Peak (dB)	Average (dB)	
0.15	50.82	39.77	66	56	15.18	16.23	10.23
0.158	50.19	40.31	65.57	55.57	15.38	15.26	10.23
0.194	33.44	16.62	63.86	53.86	30.42	37.24	10.18
0.206	34.23	16.61	63.37	53.37	29.14	36.76	10.18
4.634	34.81	28.73	56	46	21.19	17.27	10.4
5.39	38.64	31.61	60	50	21.36	18.39	10.44
15.326	34.92	28.03	60	50	25.08	21.97	10.68
17.078	36.44	29.67	60	50	23.56	20.33	10.66
18.278	37.38	33.77	60	50	22.62	16.23	10.65
22.27	29.56	25.38	60	50	30.44	24.62	10.77

Table 7.2.2-4: Conducted EMI Results Line 2 – 277Vac / 60Hz

Frequency (MHz)	Corrected Reading		Limit		Margin		Correction (dB)
	Quasi-Peak (dBuV)	Average (dBuV)	Quasi-Peak (dBuV)	Average (dBuV)	Quasi-Peak (dB)	Average (dB)	
0.15	50.66	39.36	66	56	15.34	16.64	10.21
0.154	50.23	41.61	65.78	55.78	15.55	14.17	10.21
0.19	35.06	18.14	64.04	54.04	28.98	35.9	10.19
4.682	34.54	29.26	56	46	21.46	16.74	10.41
5.466	37.64	30.81	60	50	22.36	19.19	10.45
17.694	33.52	25.59	60	50	26.48	24.41	10.69
18.234	36.17	29.15	60	50	23.83	20.85	10.68
22.526	34.16	28.13	60	50	25.84	21.87	10.84
23.874	41.1	30.69	60	50	18.9	19.31	10.94
25.758	43.63	32.27	60	50	16.37	17.73	11.04

### 7.3 Emission Levels

#### 7.3.1 Emissions into Restricted Frequency Bands – FCC: Section 15.205, 15.209; ISED Canada: RSS-Gen 8.9 / 8.10

##### 7.3.1.1 Measurement Procedure

The unwanted emissions into restricted bands were measured radiated over the frequency range of 30 MHz to 25 GHz, 10 times the highest fundamental frequency.

The EUT was rotated through 360° and the receive antenna height was varied from 1 meter to 4 meters so that the maximum radiated emissions level would be detected. For frequencies below 1000 MHz, quasi-peak measurements were made using a resolution bandwidth RBW of 120 kHz and a video bandwidth VBW of 300 kHz. For frequencies above 1000 MHz, peak measurements were made with RBW and VBW of 1 MHz and 3 MHz respectively. Average measurements were performed in linear amplitude mode with a reduced video bandwidth of 100 Hz.

Each emission found to be in a restricted band as defined by section 15.205, including any emission at the operational band-edge, was compared to the radiated emission limits as defined in section 15.209.

##### 7.3.1.2 Duty Cycle Correction

For average radiated measurements, using a 63.011% duty cycle, the measured level was reduced by a factor of 4.01 dB. The duty cycle correction factor is determined using the formula:  $20\log(63.011/100) = -4.01$  dB. A detailed analysis of the duty cycle timing is provided in the Theory of Operation accompanying the original application for certification.

##### 7.3.1.3 Measurement Results

Performed by: Mark Afroozi, Tyler Leeson

**Table 7.5.2.3-1: Radiated Spurious Emissions Tabulated Data**

Frequency (MHz)	Level (dBuV)		Antenna Polarity (H/V)	Correction Factors (dB)	Corrected Level (dBuV/m)		Limit (dBuV/m)		Margin (dB)	
	pk	Qpk/Avg			pk	Qpk/Avg	pk	Qpk/Avg	pk	Qpk/Avg
<b>Lowest Channel</b>										
4804	49.50	38.84	H	2.86	52.36	37.69	74.0	54.0	21.6	16.3
4804	51.90	41.83	V	2.86	54.76	40.68	74.0	54.0	19.2	13.3
<b>Middle Channel</b>										
4880	51.12	40.92	H	3.14	54.26	40.05	74.0	54.0	19.7	13.9
4880	52.20	39.98	V	3.14	55.34	39.11	74.0	54.0	18.7	14.9
7320	49.17	37.05	H	8.36	57.53	41.40	74.0	54.0	16.5	12.6
7320	50.91	38.62	V	8.36	59.27	42.97	74.0	54.0	14.7	11.0
<b>Highest Channel</b>										
2483.5	65.70	36.71	H	-4.70	61.00	27.99	74.0	54.0	13.0	26.0
2483.5	62.10	35.80	V	-4.70	57.40	27.08	74.0	54.0	16.6	26.9
4960	50.40	37.70	H	3.44	53.84	37.13	74.0	54.0	20.2	16.9
4960	51.50	39.56	V	3.44	54.94	38.99	74.0	54.0	19.1	15.0
7440	49.30	35.41	H	8.42	57.72	39.82	74.0	54.0	16.3	14.2
7440	50.80	36.02	V	8.42	59.22	40.43	74.0	54.0	14.8	13.6
12400	51.00	37.79	H	17.83	68.83	51.61	83.5	63.5	14.7	11.9
12400	51.10	37.97	V	17.83	68.93	51.79	83.5	63.5	14.6	11.7

**7.3.1.4 Sample Calculation:**

$$R_C = R_U + CF_T$$

Where:

$CF_T$	=	Total Correction Factor (AF+CA+AG)-DC (Average Measurements Only)
$R_U$	=	Uncorrected Reading
$R_C$	=	Corrected Level
AF	=	Antenna Factor
CA	=	Cable Attenuation
AG	=	Amplifier Gain
DC	=	Duty Cycle Correction Factor

**Example Calculation: Peak**Corrected Level:  $49.50 + 2.86 = 52.36\text{dBuV/m}$ Margin:  $74\text{dBuV/m} - 52.36\text{dBuV/m} = 21.6\text{dB}$ **Example Calculation: Average**Corrected Level:  $38.84 + 2.86 - 4.01 = 37.69\text{dBuV}$ Margin:  $54\text{dBuV} - 37.69\text{dBuV} = 16.3\text{dB}$



## 8 ESTIMATION OF MEASUREMENT UNCERTAINTY

The expanded laboratory measurement uncertainty figures ( $U_{\text{Lab}}$ ) provided below correspond to an expansion factor (coverage factor)  $k = 1.96$  which provide confidence levels of 95%.

**Table 8-1: Estimation of Measurement Uncertainty**

Parameter	$U_{\text{Lab}}$
Occupied Channel Bandwidth	$\pm 0.009 \%$
RF Conducted Output Power	$\pm 0.349 \text{ dB}$
Power Spectral Density	$\pm 0.372 \text{ dB}$
Antenna Port Conducted Emissions	$\pm 1.264 \text{ dB}$
Radiated Emissions $\leq 1 \text{ GHz}$	$\pm 5.814 \text{ dB}$
Radiated Emissions $> 1 \text{ GHz}$	$\pm 4.318 \text{ dB}$
Temperature	$\pm 0.860 \text{ }^\circ\text{C}$
Radio Frequency	$\pm 2.832 \times 10^{-8}$
AC Power Line Conducted Emissions	$\pm 3.360 \text{ dB}$

## 9 CONCLUSION

In the opinion of TÜV SÜD America, Inc. the BRM1-3, manufactured by Acuity Brands Lighting meets the requirements of FCC Part 15 subpart C and Innovation, Science, and Economic Development Canada's Radio Standards Specification RSS-247 for Class II Permissive Change for the tests documented in this test report.

**END REPORT**