



America

---

## **Certification Exhibit**

**FCC ID: 2ADCB-BRM1  
IC: 6715C-BRM1**

**FCC Rule Part: 15.247  
ISED Canada Radio Standards Specification: RSS-247**

**Project Number: 72133675**

**Manufacturer: Acuity Brands Lighting, Inc.  
Model: BRM1-3**

## **Manual**

## BRM1 BLE Beacon

This product is a BLE beacon that is incorporated into lighting fixtures. It integrates with geo-location devices that use either both or only one mode of VLC (Visual Light Communication) or BLE. Location accuracy depends upon the user's phone position relative to the lighting fixture. For optimum location accuracy, the phone should be allowed for VLC communication, by performing the following steps:

1. Locate mobile directly underneath lighting fixture.
2. Phone should be facing upward direction, screen side up.
3. Camera should not be covered.

When not in optimum position or the device is unable to read to visual light communication data, position accuracy will default to the BRM for location information. In some instance, this may be slightly less precise than VLC positioning. In order for the BRM to function properly, your device's Bluetooth should be turned on, and the user location should not be greater than 50 feet from any fixture equipped with the BRM location device.

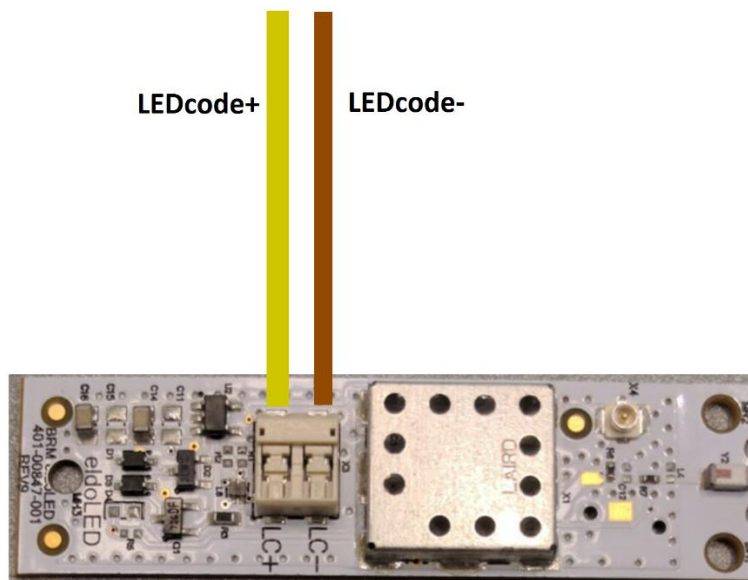

**Note:** Applications specific to a particular store will provide additional details about the availability functionality and user interface with mobile devices.

There are 3 SKUs each providing a singular radiated antenna solution with the BRM1 module: 1. using an internal chip antenna, 2. using an internal chip antenna with different antenna path tuning components and 3. providing a unique RF connector for external antenna connection. The internal chip antenna option incorporated in the design is manufactured by Johanson Technology (part number 2450AT18A100E) and it has a peak gain of +0.5 dBi (see reference radiation pattern from the manufacturer below). The external antenna option will connect to a U.FL or equivalent connector and will connect to an off-the-shelf printed inverted F antenna (PIFA) design by Pulse Electronics (part number W3525B) with peak gain +2dBi. **It is important to note that under no circumstances both chip antenna and external PIFA antenna can be utilized at the same time on a single BRM1 module.**

# **BRM1 Regulatory Warning Sheet**

**Warning: Changes or modifications to this device not expressly approved by Acuity Brands Lighting, Inc. could void the user's authority to operate the equipment.**

*"NOTE: This equipment has been tested and found to comply with the limits for a Class B digital device, pursuant to Part 15 of the FCC Rules. These limits are designed to provide reasonable protection against harmful interference in a residential installation. This equipment generates, uses, and can radiate radio frequency energy and, if not installed and used in accordance with the instructions, may cause harmful interference to radio communications. However, there is no guarantee that interference will not occur in a particular installation. If this equipment does cause harmful interference to radio or television reception, which can be determined by turning the equipment off and on, the user is encouraged to try to correct the interference by one or more of the following measures:*

- Reorient or relocate the receiving antenna.*
- Increase the separation between the equipment and receiver.*
- Connect the equipment into an outlet on a circuit different from that to which the receiver is connected.*
- Consult the dealer or an experienced radio/TV technician for help."*

*This device complies with Part 15 of the FCC Rules. Operation is subject to the following two conditions: (1) This device may not cause harmful interference and (2) this device must accept any interference received, including interference that may cause undesired operation.*

*"This equipment complies with FCC and Industry Canada RSS-102 radiation exposure limits set forth for an uncontrolled environment. This equipment should be installed and operated with minimum distance 20cm between the radiator and your body. This transmitter must not be co-located or operating in conjunction with any other antenna or transmitter."*

*"Cet équipement est conforme aux limites FCC et d'Industrie Canada RSS-102 d'exposition aux radiations définies pour un environnement non contrôlé. Cet équipement doit être installé et utilisé à distance minimum de 20cm entre le radiateur et votre corps. Cet émetteur ne doit pas être co-localisées ou opérant en conjonction avec tout autre antenne ou transmetteur."*

*Under Industry Canada regulations, this radio transmitter may only operate using an antenna of a type and maximum (or lesser) gain approved for the transmitter by Industry Canada. To reduce potential radio interference to other users, the antenna type and its gain should be so chosen that the equivalent isotropically radiated power (e.i.r.p.) is not more than that necessary for successful communication.*

*Conformément à la réglementation d'Industrie Canada, le présent émetteur radio peut fonctionner avec une antenne d'un type et d'un gain maximal (ou inférieur) approuvé pour l'émetteur par Industrie Canada. Dans le but de réduire les risques de brouillage radioélectrique à l'intention des autres utilisateurs, il faut choisir le type d'antenne et son gain de sorte que la puissance isotrope rayonnée équivalente (p.i.r.e.) ne dépasse pas l'intensité nécessaire à l'établissement d'une communication satisfaisante.*

*This radio transmitter (IC: 6715C-BRM1) has been approved by Industry Canada to operate with the antenna types listed below with the maximum permissible gain and required antenna impedance for each antenna type indicated. Antenna types not included in this list, having a gain greater than the maximum gain indicated for that type, are strictly prohibited for use with this device.*

*Le présent émetteur radio (IC: 6715C-BRM1) a été approuvé par Industrie Canada pour fonctionner avec les types d'antenne énumérés ci-dessous et ayant un gain admissible maximal et l'impédance requise pour chaque type d'antenne. Les types d'antenne non inclus dans cette liste, ou dont le gain est supérieur au gain maximal indiqué, sont strictement interdits pour l'exploitation de l'émetteur.*

**Antenna type:** Printed Inverted F Antenna (PIFA)

**Maximum Gain:** 2 dBi

**Required Impedance:** 50 Ohm

*This device complies with Industry Canada license-exempt RSS standard(s). Operation is subject to the following two conditions: (1) this device may not cause interference, and (2) this device must accept any interference, including interference that may cause undesired operation of the device.*

*Le présent appareil est conforme aux CNR d'Industrie Canada applicables aux appareils radio exempts de licence. L'exploitation est autorisée aux deux conditions suivantes : (1) l'appareil ne doit pas produire de brouillage, et (2) l'utilisateur de l'appareil doit accepter tout brouillage radioélectrique subi, même si le brouillage est susceptible d'en compromettre le fonctionnement.*