



**⚠ Read this manual carefully before operating the system.  
This manual should stay with this system if it is sold.**

# OWNER'S MANUAL

---

## Drive Unit Display Unit Battery Pack Battery Charger

---

- \* This owner's manual is original instruction.
- \* Product and specifications are subject to change without notice.



# Introduction

---

These original instructions have been prepared for your Drive Unit, display unit, battery pack and battery charger.

## **TIP**

---

This manual is not intended as a comprehensive use, service, repair or maintenance manual. Please see your dealer for all service, repairs or maintenance. Your dealer may also be able to refer you to classes, clinics or books on bicycle use, service, repair or maintenance.

---

**Drive Unit, Display Unit,  
Battery Pack, Battery Charger  
OWNER'S MANUAL  
©2018 by Yamaha Motor Co., Ltd.  
1st edition, April 2018  
All rights reserved.  
Any reprinting or unauthorized use  
without the written permission of  
Yamaha Motor Co., Ltd.  
is expressly prohibited.**

# Contents





---

General warning	p. 1
1. Electric bike components	p. 2
A. Introduction	p. 2
B. Location of the warning and specification labels	p. 3
C. Description	p. 4
D. E-Bike Systems	p. 5
The e-Bike Systems are designed to give you the optimal amount of power assist.	p. 5
Multiple power assist modes are available.	p. 5
Conditions that could decrease remaining assist distance	p. 6
E. ⚠ Safety information	p. 7
F. Instrument and control functions	p. 10
Display unit (Display A)	p. 10
Display unit (Display X)	p. 16
G. Battery pack and charging procedure	p. 34
Appropriate charging environments	p. 35
Inappropriate charging environments and solutions	p. 36
Charging the battery pack mounted on the bicycle (Down tube type)	p. 36
Charging the battery pack mounted on the bicycle (Multi location type)	p. 37
Charging the battery pack removed from the bicycle	p. 38
Reading the charging status for battery pack	p. 42
Reading the charging status for display unit (Applies only to models equipped with the Multi location type battery pack.)	p. 43
Charging time guidelines	p. 44
H. Checking the residual battery capacity	p. 45
Residual battery capacity indicator display and estimate of residual battery capacity for display unit	p. 45
Display of the battery capacity indicator lamps and the estimate of the residual battery capacity	p. 46
I. Pre-operation check	p. 47
J. Cleaning, maintenance and storage	p. 47
Caring for the battery pack	p. 47
Maintenance for the Drive Unit	p. 47
Storage	p. 48
Long storage period (1 month or longer) and using it again after a long storage period	p. 48
K. Transport	p. 48
L. Consumer information	p. 49
Disposal	p. 49
M. Troubleshooting	p. 50
E-Bike Systems	p. 50
Power supply of external devices via USB connection	p. 54
Wireless communication with Bluetooth low energy technology	p. 55
Battery pack and charger	p. 56
N. Specifications	p. 59

# General warning

FAILURE TO FOLLOW THE WARNINGS CONTAINED IN THIS MANUAL CAN RESULT IN SERIOUS INJURY OR DEATH.

Particularly important information is distinguished in this manual by the following notations:

	<b>This is the safety alert symbol. It is used to alert you to potential personal injury hazards. Obey all safety messages that follow this symbol to avoid possible injury or death.</b>
	<b>A WARNING indicates a hazardous situation which, if not avoided, could result in death or serious injury.</b>
	<b>A NOTICE indicates special precautions that must be taken to avoid damage to the vehicle or other property.</b>
	<b>A TIP provides key information to make procedures easier or clearer.</b>

# 1. Electric bike components

---

## A. Introduction



The Bluetooth® word mark and logos are registered trademarks owned by the Bluetooth SIG, Inc. and any use of such marks by YAMAHA MOTOR CO., LTD. is under license.

\*Applies only to the Display X.

## B. Location of the warning and specification labels

Read and understand all of the labels on your battery pack and battery charger. These labels contain important information for safe and proper operation. Never remove any labels from your battery pack and battery charger:



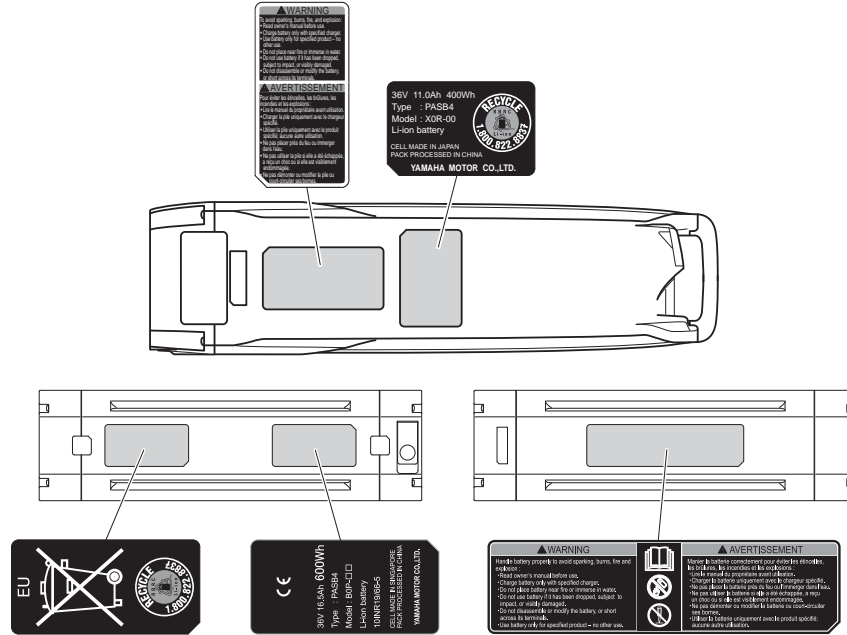

### Battery pack

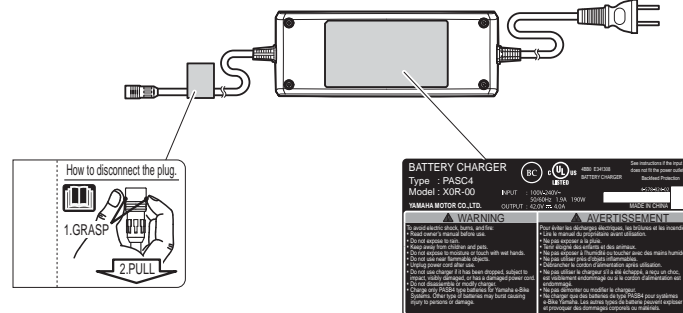

### Battery charger



Familiarize yourself with the following pictograms and read the explanatory text, then make sure to check the pictograms that apply to your model.

-  Read the Owner's manual
-  Do not dispose of in a fire
-  Do not disassemble
-  Do not use with wet hands

## C. Description

1

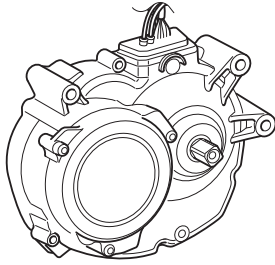

2

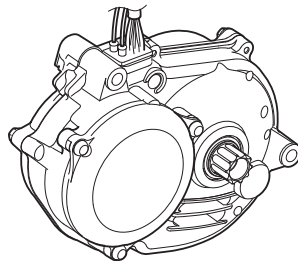

3

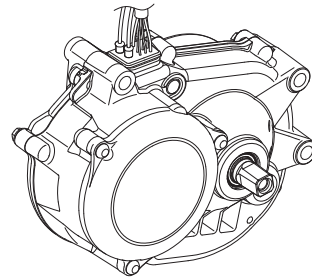

4

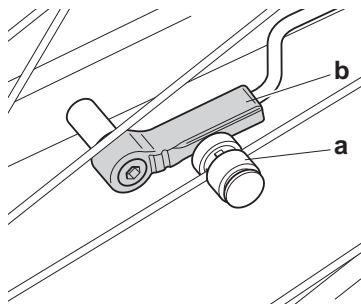

5

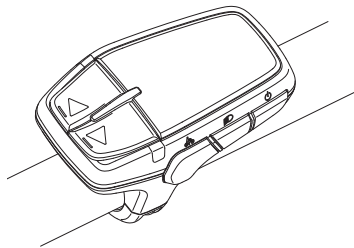

6

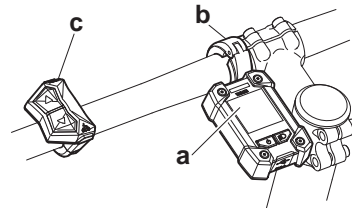

7

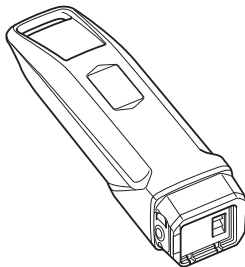

8

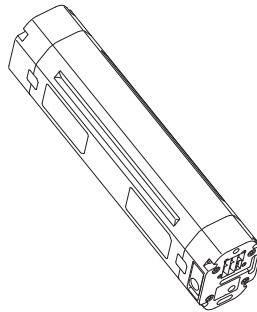

9

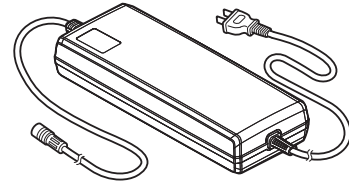

1. Drive Unit (PWseries SE)
2. Drive Unit (PW-X)
3. Drive Unit (PWseries TE)
4. Speed sensor set
  - a) Magnet sensor spoke type
  - b) Pick up
5. Display unit (Display A)

6. Display unit (Display X)
  - a) Display
  - b) Clamp
  - c) Switch
7. Battery pack (Down tube type  
400 Wh/500 Wh)

8. Battery pack (Multi location  
type 600 Wh)
9. Battery charger



## D. E-Bike Systems

**The e-Bike Systems are designed to give you the optimal amount of power assist.**

It assists you within a standard range based on factors such as your pedaling strength, bicycle speed, and current gear.

The e-Bike Systems do not assist in the following situations:

- When the display unit's power is off.
  - When you are moving 20 mph (32 km/h) or faster.
  - When you are not pedaling and the pushing assist switch is released.
  - When there is no residual battery capacity.
  - When the automatic power off function\* is operating.
- \* Power turns off automatically when you do not use the e-Bike Systems for 5 minutes.
- When the assist mode is set to Off mode.

**Multiple power assist modes are available.**

Choose from Extra Power mode, High-Performance mode, Standard mode, Eco mode, +Eco mode, Off mode and Automatic mode to suit your riding conditions.

See "Displaying and switching the assist mode" for information on switching between assist modes.

<b>Extra Power mode</b> <sup>*1</sup>	Use when climbing rough terrain.
<b>High-Performance mode</b>	Use when you want to ride more comfortably, such as when climbing a steep hill.
<b>Standard mode</b>	Use when riding on flat roads or climbing gentle hills.
<b>Eco mode +Eco mode</b>	Use when you want to ride as far as possible.
<b>Off mode</b>	Use when you want to ride without power assist. You can still use the other display unit functions.
<b>Automatic mode</b> <sup>*2</sup>	Use when you want the assist mode to change automatically to the best suited mode depending on the riding conditions.

\*1 Applies only to the Drive Unit (PW-X).

\*2 Applies only to the Drive Unit (PWseries TE).

## Conditions that could decrease remaining assist distance

The remaining assist distance will decrease when riding in the following conditions:

- Frequent starts and stops
- Numerous steep inclines
- Poor road surface conditions
- When riding together with children
- Riding into a strong head wind
- Low air temperature
- Worn-out battery pack
- When using the headlight (applies only to models equipped with lights powered by the battery pack)
- Frequent acceleration
- Heavier rider and luggage weight
- Higher assist mode
- Higher riding speed

Remaining assist distance will also decrease if the bicycle is not maintained properly.

Examples of inadequate maintenance that could decrease remaining assist distance:

- Low tire pressure
- Chain not turning smoothly
- Brake engaged constantly

## **E. ⚠ Safety information**

**Never use this battery charger to charge other electrical appliances.**

**Do not use any other charger or charging method to recharge the special batteries. Using any other charger could result in fire, explosion, or damage the batteries.**

**This battery charger can be used by children aged from 8 years and above and persons with reduced physical, sensory or mental capabilities or lack of experience and knowledge if they have been given supervision or instruction concerning use of the battery charger in a safe way and understand the hazards involved. Children shall not play with the battery charger. Cleaning and user maintenance shall not be made by children without supervision.**

**Although the battery charger is waterproof, never allow it to become immersed in water or other fluids. In addition, never use the battery charger if the terminals are wet.**

**Never handle the power plug, charging plug or touch the charger contacts with wet hands. This could result in electric shock.**

**Do not touch charger contacts with metallic objects. Do not allow foreign material to cause short circuit of the contacts. This could result in electric shock, fire, or damage the battery charger.**

**Periodically remove dust from the power plug. Dampness or other issues could reduce the effectiveness of the insulation, resulting in fire.**

**Never disassemble or modify the battery charger. This could result in fire or electric shock.**

**Do not use with a power strip or extension cord. Using a power strip or similar methods may exceed rated current and can result in fire.**

**Do not use with the cable tied or rolled up, and do not store with the cable wrapped around the charger main body. Cable damage can result in fire or electric shock.**

**Firmly insert the power plug and the charging plug into the socket. Failure to insert the power plug and the charging plug completely can result in fire caused by electric shock or overheating.**

**Do not use the battery charger near flammable material or gas. This could result in fire or explosion.**

**Never cover the battery charger or place other objects on top of it while charging. This could result in internal overheating leading to fire.**

**Do not drop the battery charger or expose it to strong impacts. Otherwise, it could cause a fire or electric shock.**

**Store the battery pack and battery charger out of reach of children.**

**Do not touch the battery pack or battery charger while it is charging. As the battery pack or battery charger reaches 104–158 °F (40–70 °C) during charging, touching it could result in burns.**

**Do not use if the battery pack case is damaged, cracked, or if you smell any unusual odors. Leaking battery fluid can cause serious injury.**

**Do not short the contacts of the battery pack. Doing so could cause the battery pack to become hot or catch fire, resulting in serious injury or property damage.**

**Do not disassemble or modify the battery pack. Doing so could cause the battery pack to become hot or catch fire, resulting in serious injury or property damage.**

**If the power cable is damaged, stop using the battery charger and have it inspected at an authorized dealer.**

**Do not turn the pedals or move the bicycle while the battery charger is connected. Doing so could cause the power cable to become tangled in the pedals, resulting in damage to the battery charger, power cable, and/or plug.**

**Handle the power cable with care. Connecting the battery charger from indoors while the bicycle is outdoors could result in the power cable becoming pinched and damaged in a doorway or window.**

**Do not run over the power cable or plug with the wheels of the bicycle. Doing so could result in damage to the power cable or plug.**

**Do not drop the battery pack or subject it to impact. Doing so could cause the battery pack to become hot or catch fire, resulting in serious injury or property damage.**

**Do not dispose of the battery pack in a fire or expose it to a heat source. Doing so could cause fire, or explosion, resulting in serious injury or property damage.**

**Do not modify or disassemble the e-Bike Systems. Do not install anything other than genuine parts and accessories. Doing so could result in product damage, malfunction, or increase your risk of injury.**

**When stopped, be sure to apply the front and rear brakes and keep both feet on the ground. Placing one's foot on the pedal when stopped may unintentionally engage the power assist function, which could result in loss of control and serious injury.**

**Do not ride the bicycle if there is any irregularity with the battery pack or e-Bike Systems. Doing so could lead to loss of control and serious injury.**

**Be sure to check the residual battery capacity before riding at night. The headlight powered by the battery pack will turn off soon after the residual battery capacity has decreased to where power assisted riding is no longer possible. Riding without an operating headlight can increase your risk of injury.**

**Do not start off by running with one foot on a pedal and one foot on the ground and then mounting the bicycle after it has reached a certain speed. Doing so could result in loss of control or serious injury. Be sure to start riding only after you are seated properly on the bicycle seat.**

**Do not press the pushing assist switch if the rear tire is off the ground. Otherwise, the tire will turn at high speed in the air and you could be injured.**

**Do not use the wireless function with Bluetooth low energy technology in areas such as hospitals or medical institutions where use of electronic equipment or wireless equipment is prohibited. Otherwise, this could affect the medical equipment, etc. and cause an accident.**

**When using the wireless function with Bluetooth low energy technology, keep the display at a safe distance from heart pacemakers in use. Otherwise, the radio waves could affect the heart pacemaker function.**

**Do not use the wireless function with Bluetooth low energy technology near automatic control equipment such as automatic doors, fire alarms, etc. Otherwise, the radio waves could affect the equipment and cause an accident through possible malfunction or unintentional operation.**

## F. Instrument and control functions

### Display unit (Display A)

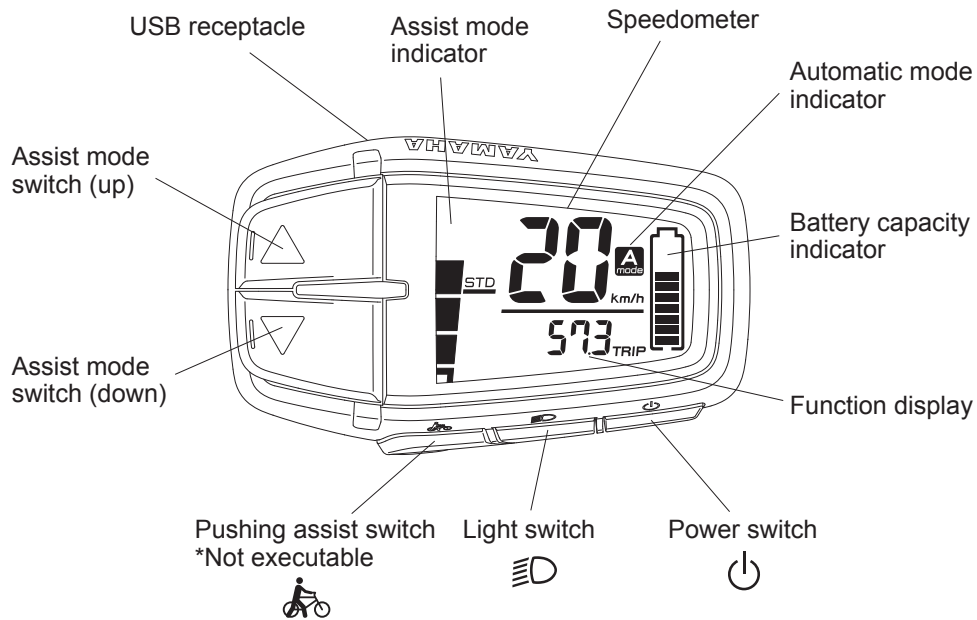

#### TIP

The USB receptacle is for connecting the designated YAMAHA tool; it cannot be used as a power supply.

## Display unit (Display A)

The display unit offers the following operations and information displays.

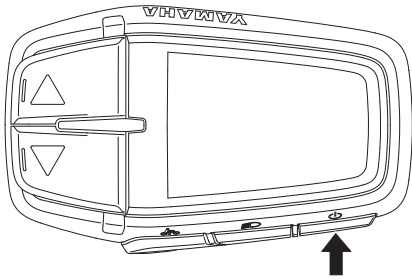
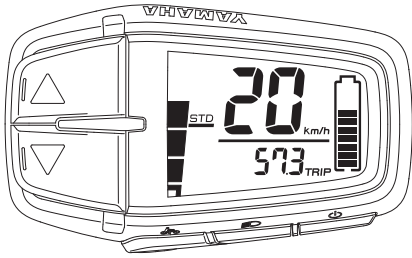

### ○ Power “On/Off”

Each time you press the power switch, the power switches between “On” and “Off”.

When you turn on the power, all of the displays come up. After that, it transitions to the main riding display.

### TIP

- When you turn on the power, the assist mode is automatically set to Standard mode or High-Performance mode.
- Keep your feet off the pedals when turning on the display unit. Also, do not start riding immediately after turning on the display unit. Doing so could weaken the assist power. (Weak assist power in either of these cases is not a malfunction.) If you did either of the above by accident, remove your feet from the pedals, turn on the power again, and wait a moment (approximately two seconds) before starting to ride.

### ○ Displaying and switching the assist mode

You can select the assist mode by using the assist mode switches (up & down).

The selected assist mode is displayed by the assist mode indicator.

- When you press the assist mode switch (up), the mode changes from “OFF” to “+ECO”, or from “+ECO” to “ECO”, or “ECO” to “STD”, or “STD” to “HIGH”, or “HIGH” to “EXPW”.
- When you press the assist mode switch (down), the mode changes from “EXPW” to “HIGH”, or from “HIGH” to “STD”, or “STD” to “ECO”, or “ECO” to “+ECO” or “+ECO” to “OFF”.

### TIP

- Bicycles equipped with the PWseries SE or PWseries TE drive unit has no Extra Power mode.
- Further pressing of the assist mode switch will not cycle the assist mode selections.

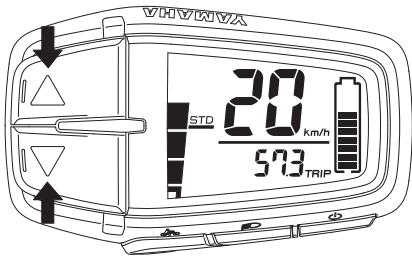

Bicycles equipped with the PWseries TE drive unit can use the Automatic mode.

**TIP**

The automatic mode is a function enabling automatic change to the optimized assist mode according to the riding conditions.

- To use the Automatic mode, press the assist mode switch (up) for 1 second or longer. The Automatic mode indicator will light up and the mode will be changed to the Automatic mode.
- To cancel the Automatic mode, press the assist mode switch (up) for 1 second or longer. The Automatic mode indicator will go off and the Automatic mode will be canceled.

**TIP**

- Even if you press the assist mode switch (up & down) while in Automatic mode, the assist mode cannot be changed.
- The Automatic mode is saved when the power is turned off. When you turn on the power again, the assist mode will be in the Automatic mode.

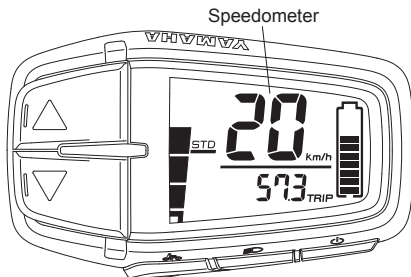
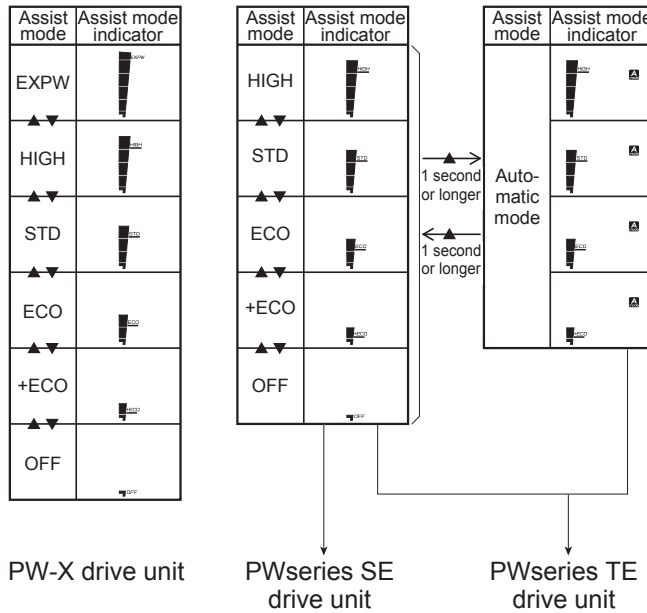
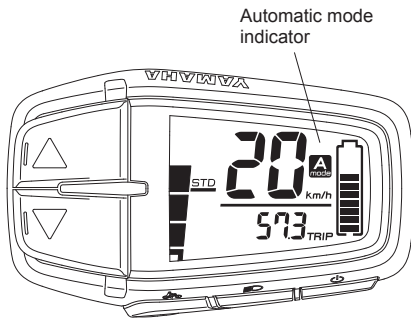

○ **Speedometer**

The speedometer displays your bicycle speed (in kilometer per hour or mile per hour). To select the km/mile, see “km/mile setting”.

**TIP**

If your bicycle speed is less than 2.0 km/h or 1.2 MPH, the speedometer displays “0 km/h or 0 MPH”.



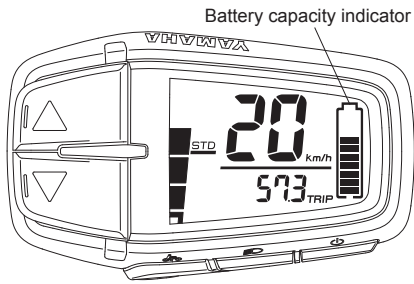

Battery capacity indicator

### ○ Battery capacity indicator

The battery capacity indicator displays an estimate of how much capacity is left in the battery.

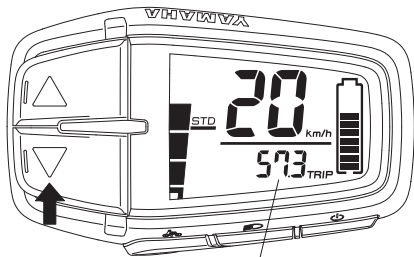

Function display

### ○ Function display

The function display can display the following functions.

- Odometer
- Trip meter
- Range (Remaining assist distance)

Push the assist mode switch (down) for 1 second or longer, the display changes as follows:

Odometer → Trip meter → Range → Odometer

You can reset the data for trip meter.

### ● Odometer

This displays the total distance (in kilometers or miles) ridden while the power was on. The odometer cannot be reset.

157<sup>000</sup>

### ● Trip meter

This displays the total riding distance (in kilometers or miles) since it was last reset.

When you turn off the power, the data up to that point will remain in the display.

To reset the trip meter and begin counting a new total, press the assist mode switch (up) and assist mode switch (down) simultaneously for 2 seconds or longer when the trip meter is displayed.

331<sup>TRIP</sup>

### ● Range (Remaining assist distance)

This displays an estimate of the distance (in kilometers or miles) that can be ridden with assist on the residual battery capacity of the battery installed. If you switch the assist mode when the remaining assist distance is displayed, the estimate of the distance that can be ridden with assist changes.

The remaining assist distance estimate cannot be reset.

86  
RANGE

### TIP

- The remaining assist distance changes depending on the riding situation (hills, headwind, etc.) and as the battery runs down.
- If in Off mode, “- - - -” is displayed.

- **Headlight “On/Off” (Applies only to models equipped with a headlight powered by the battery pack. The taillight, which is powered by the battery pack, is switched on/off with the headlight.)** 

Each time you press the light switch, the headlight switches between “On” and “Off”.

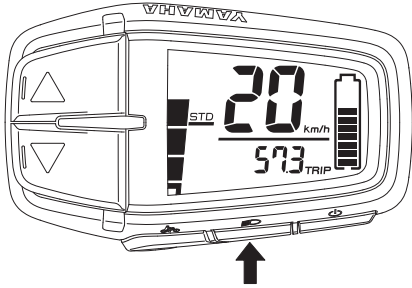

- **km/mile setting**

Use the following steps to set the km/mile setting.

1. Make sure that the display unit is turned on.
2. Select the odometer display in the function display.
3. Press the assist mode switch (up) and assist mode switch (down) simultaneously for 2 seconds or longer.
4. When either “km” or “mile” flashes, release the switch.
5. Use the assist mode switches (up & down) to set the “km/mile”.
6. While the unit that you want to set is flashing, press the assist mode switch (down) for 1 second or longer, and release the switch when the display returns to the main riding display.

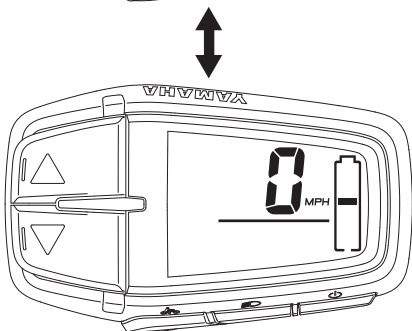
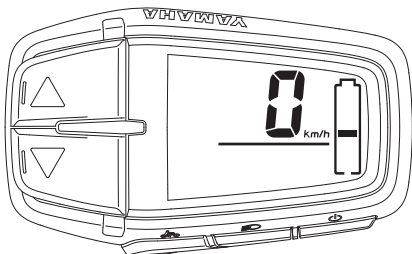
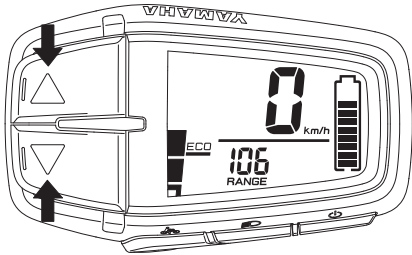

#### **WARNING**

For all setting procedures, be sure to stop the bicycle and perform the required settings in a safe location. Otherwise, lack of attention to surrounding traffic or other hazards could cause an accident.

#### **TIP**

- The settings cannot be adjusted while riding.
- If you do the following during setting, the item that you are setting will be canceled and the display will return to the main riding display.
- Turning the crank (pedal) in the traveling direction
- Turning the rear wheel at 1.2 mph (2 km/h) and more
- Pushing the pushing assist switch

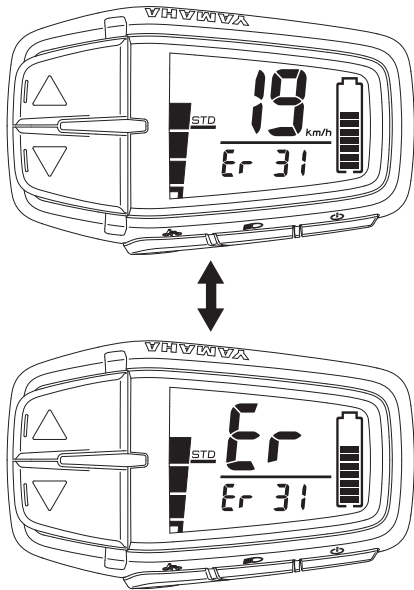

### ○ Diagnosis mode

The e-Bike Systems are equipped with a diagnosis mode. If a malfunction or fault occurs in the e-Bike Systems, the main riding display and “Er” will be shown alternately, while an error description will inform you of the type of error in the function display. See “Troubleshooting” regarding symptoms and remedies for abnormal displays and abnormal flashing.

### ⚠ WARNING

If the problem cannot be solved, have your bicycle inspected by a dealer as soon as possible.

## Display unit (Display X)



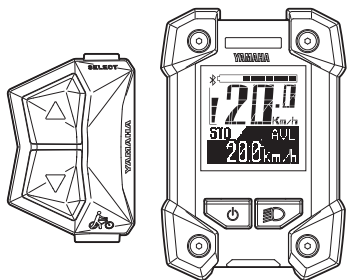

## Display unit (Display X)

The display unit offers the following operations and information displays.

### NOTICE

This device complies with part 15 of the FCC Rules and Industry Canada licence exempt RSS-247 standard. Operations is subject to the following two conditions (1) This device may not cause harmful interference, and (2) This device must accept any interference received, including interference that may cause undesired operation.

Le manuel d'utilisation des appareils radio exempts de licence doit contenir l'énoncé qui suit, ou l'équivalent, à un endroit bien en vue et/ou sur les appareils : Le présent appareil est conforme aux CNR d'Industrie Canada applicables aux appareils radio exempts de licence. L'exploitation est autorisée aux deux conditions suivantes : (1) l'appareil ne doit pas produire de brouillage, et (2) l'utilisateur de l'appareil doit accepter tout brouillage radioélectrique subi, même si le brouillage est susceptible d'en compromettre le fonctionnement.

FCC ID : 2ADBKX0P10  
IC : 740A-X0P10  
CAN ICES-3 (B)/NMB-3 (B)

Brand name : YAMAHA  
Model no. : X0P10  
Manufacturer name : YAMAHA MOTOR CO., LTD.

MADE IN CHINA

## **NOTICE**

### **Federal Communication Commission Interference Statement**

This equipment has been tested and found to comply with the limits for a Class B digital device, pursuant to Part 15 of the FCC Rules. These limits are designed to provide reasonable protection against harmful interference in a residential installation. This equipment generates, uses and can radiate radio frequency energy and, if not installed and used in accordance with the instructions, may cause harmful interference to radio communications. However, there is no guarantee that interference will not occur in a particular installation. If this equipment does cause harmful interference to radio or television reception, which can be determined by turning the equipment off and on, the user is encouraged to try to correct the interference by one of the following measures:

- Reorient or relocate the receiving antenna.
- Increase the separation between the equipment and receiver.
- Connect the equipment into an outlet on a circuit different from that to which the receiver is connected.
- Consult the dealer or an experienced radio/TV technician for help.

### **FCC Caution:**

To assure continued compliance, any changes or modifications not expressly approved by the party responsible for compliance could void the user's authority to operate this equipment. (Example - use only shielded interface cables when connecting to computer or peripheral devices.)

### **FCC Radiation Exposure Statement:**

This equipment complies with FCC RF radiation exposure limits set forth for an uncontrolled environment. This transmitter must not be co-located or operating in conjunction with any other antenna or transmitter.

### **IC Radiation Exposure Statement:**

This equipment complies with IC RSS-102 radiation exposure limits set forth for an uncontrolled environment. This equipment should be installed and operated with minimum distance 0.5 cm between the radiator and your body.

### **Déclaration d'exposition à la radiation:**

Cet équipement respecte les limites d'exposition aux rayonnements IC RSS-102 définies pour un environnement non contrôlé. Cet équipement doit être installé et mis en marche à une distance minimale de 0.5 cm qui sépare l'élément rayonnant de votre corps.

---

The display unit offers the following operations and information displays.

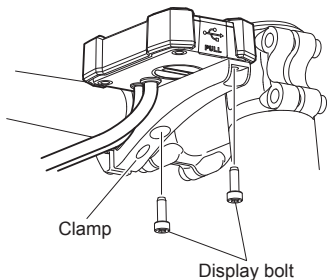

### ○ Installing the battery

The display unit needs to be removed and installed for changing the battery.

- Remove the two display bolts on back side of the clamp, and then remove the display unit.
- When installing the display unit, tighten the two display bolts from the back side of the clamp.

### ⚠ WARNING

**Tighten the display bolts to 1.5–2.5 N·m. Otherwise, during riding, vibration could cause the display bolts to come loose with the risk that the display unit may fall off. A loose display could distract the rider or interfere with control.**

### TIP

- The clamp and display unit might be installed on the right side of the stem.
- For models without this clamp, the above note does not apply.

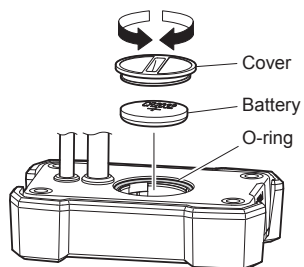

### ○ Battery

Check if the rated battery (CR2032) is installed in the rear of the display unit.

If a battery is not installed, or if there is not sufficient battery power remaining, install a new battery.

To adjust the time, see “Stopwatch and settings”.

### TIP

- Make sure that the O-ring is installed correctly.
- Use a new type CR2032 button cell battery (sold separately).
- When a battery is drained, whenever it turns on the vehicle power supply, the clock begins to count from 11:00. Please replace the battery, if such a condition appears.

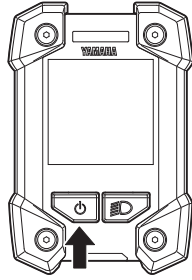

### ○ Power “On/Off”

Each time you press the power switch, the power switches between “On” and “Off”.

When you turn on the power, the animation will be displayed.

After that, it transitions to the main riding display.

### TIP

- When you turn on the power, the assist mode is automatically set to Standard mode or High-Performance mode.
- Keep your feet off the pedals when turning on the display unit. Also, do not start riding immediately after turning on the display unit. Doing so could weaken the assist power. (Weak assist power in either of these cases is not a malfunction.) If you did either of the above by accident, remove your feet from the pedals, turn on the power again, and wait a moment (approximately two seconds) before starting to ride.

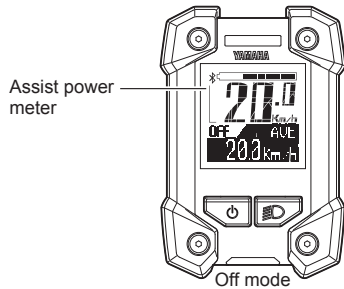
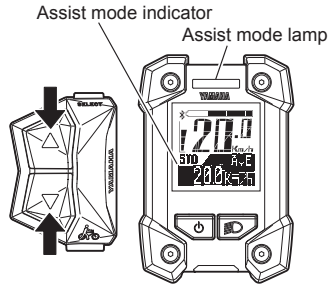

### ○ Displaying and switching the assist mode

You can select the assist mode by using the assist mode switches (up & down).

The selected assist mode is displayed by the assist mode indicator and assist mode lamp color.

- When you press the assist mode switch (up), the mode changes from “OFF” to “+ECO”, or from “+ECO” to “ECO”, or “ECO” to “STD”, or “STD” to “HIGH”, or “HIGH” to “EXPW”.
- When you press the assist mode switch (down), the mode changes from “EXPW” to “HIGH”, or from “HIGH” to “STD”, or “STD” to “ECO”, or “ECO” to “+ECO” or “+ECO” to “OFF”.

### TIP

- Bicycles equipped with the PWseries SE or PWseries TE drive unit has no Extra Power mode.
- Further pressing of the assist mode switch will not cycle the assist mode selections.
- In the Off mode, the assist power meter are not displayed.
- You can keep the assist mode lamp unlit. For more information, see “Stopwatch and settings”.



Bicycles equipped with the PWseries TE drive unit can use the Automatic mode.

**TIP**

The automatic mode is a function enabling automatic change to the optimized assist mode according to the riding conditions.

- When you use the Automatic mode, press the assist mode switch (up) for 1 second or longer. “A:” will be added to the assist mode indicator and the mode will be changed to the Automatic mode.
- To cancel the Automatic mode, press the assist mode switch (up) for 1 second or longer. “A:” will disappear from the assist mode indicator and the Automatic mode will be canceled.

**TIP**

- Even if you press the assist mode switch (up & down) while in Automatic mode, the assist mode cannot be changed.
- The Automatic mode is saved when the power is turned off. When you turn on the power again, the assist mode will be in the Automatic mode.

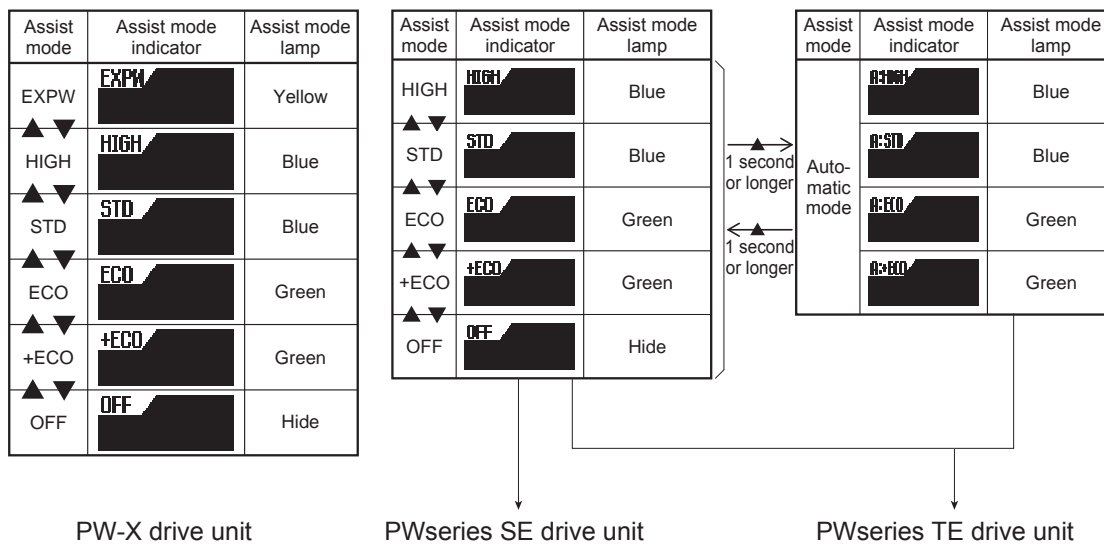

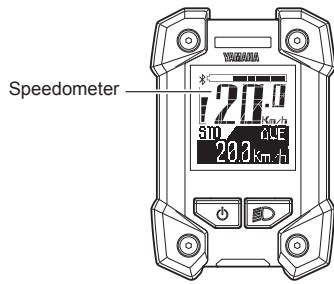

### ○ **Speedometer**

The speedometer displays your bicycle speed (in kilometer per hour or mile per hour). To select the km/mile, see “Stopwatch and settings”.

#### **TIP**

If your bicycle speed is less than 2.0 km/h or 1.2 MPH, the speedometer displays “0.0 km/h” or “0.0 MPH”.

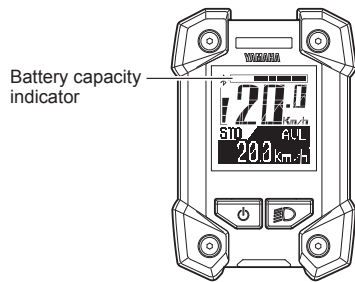

### ○ **Battery capacity indicator**

The battery capacity indicator displays an estimate of how much capacity is left in the battery.

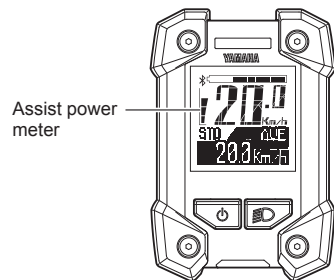

### ○ **Assist power meter**

The assist power meter displays an estimate of the assist power during riding.

When the e-Bike Systems are not in operation, none of the segments of the assist power meter are displayed. When the e-Bike Systems are operating, as the assist power increases, the segments of the assist power meter are added one by one.

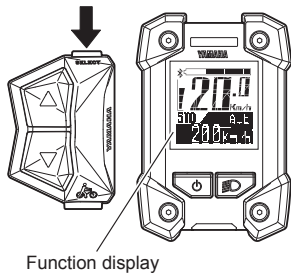

Function display

## ○ Function display

The function display can display the following functions.

- Odometer
- Trip meter
- Average bicycle speed
- Maximum bicycle speed
- Range (Remaining assist distance)
- Battery capacity (%)
- Cadence
- Clock

Push the function select switch, the display changes as follows:

Odometer → Trip meter → Average bicycle speed → Maximum bicycle speed → Range → Battery capacity (%) → Cadence → Clock → Odometer

You can select the items to be displayed.

For more information, see “Stopwatch and settings”.

You can reset the data for trip meter, average bicycle speed, and maximum bicycle speed.

For more information, see “Stopwatch and settings”.



### ● Odometer

This displays the total distance (in kilometers or miles) ridden while the power was on.

The odometer cannot be reset.



### ● Trip meter

This displays the total riding distance (in kilometers or miles) since it was last reset.

When you turn off the power, the data up to that point will remain in the display.

For the procedure of resetting the trip meter to measure a new distance travelled, see “Stopwatch and settings”.



### ● Average bicycle speed

This displays the average bicycle speed (in kilometers per hour or miles per hour) since it was last reset.

When you turn off the power, the data up to that point will remain in the display.

For the procedure of resetting the average bicycle speed, see “Stopwatch and settings”.



### ● Maximum bicycle speed

This displays the maximum bicycle speed (in kilometers per hour or miles per hour) since it was last reset.

When you turn off the power, the data up to that point will remain in the display.

For the procedure of resetting the maximum bicycle speed, see “Stopwatch and settings”.



### ● Range (Remaining assist distance)

This displays an estimate of the distance (in kilometers or miles) that can be ridden with assist on the residual battery capacity of the battery installed. If you switch the assist mode when the remaining assist distance is displayed, the estimate of the distance that can be ridden with assist changes.

The remaining assist distance estimate cannot be reset.

#### TIP

- The remaining assist distance changes depending on the riding situation (hills, headwind, etc.) and as the battery runs down.
- If in Off mode, “- - -” is displayed.



### ● Battery capacity (%)

This displays the power remaining in the battery.

The residual battery capacity display cannot be reset.



### ● Cadence

This displays your pedaling speed in revolutions per minute.

The pedaling cadence display cannot be reset.

#### TIP

If you pedal in backward, “0” is displayed.



### ● Clock

Displays the current time in 24 hour format. To adjust the time, see “Stopwatch and settings”.

- **Headlight “On/Off” (Applies only to models equipped with a headlight powered by the battery pack. The taillight, which is powered by the battery pack, is switched on/off with the headlight.)** 

Each time you press the light switch, the headlight switches between “On” and “Off”.



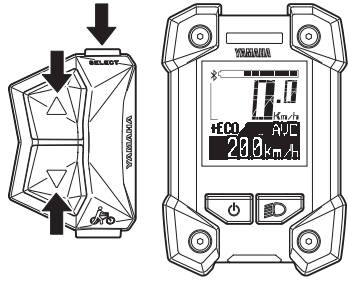

Main riding display

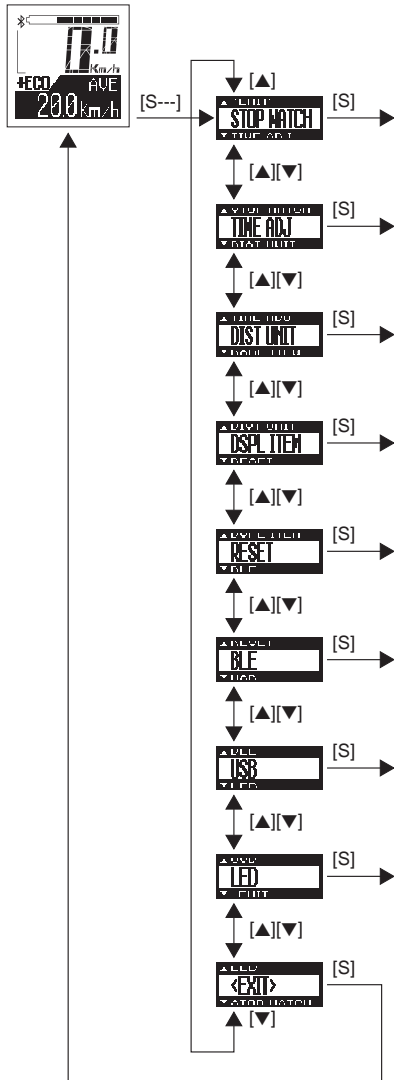

## ○ Stopwatch and settings

The display enables the following.

- **STOPWATCH**  
Stopwatch function
  - **TIME ADJ (TIME ADJUST)**  
Clock setting
  - **DIST UNIT (DISTANCE UNIT)**  
km/mile setting
  - **DSPL ITEM (DISPLAY ITEM)**  
Sets the items to be displayed in the function display during normal riding.
  - **RESET**  
Resets the values of the trip meter, average bicycle speed, and maximum bicycle speed.
  - **BLE (Bluetooth low energy technology)**  
Switches the profiles and turns off the wireless function.
  - **USB**  
Switches the USB receptacle between a power supply port and a wired communication port.
  - **LED**  
Changes between lighting the assist mode lamp and keeping the assist mode lamp unlit.
1. Press the function select switch for 2 seconds or longer.
  2. Select an item by using the assist mode switches (up & down).  
Press the function select switch at the displayed item that you want to select, and the selected item will then be displayed.  
Selecting "EXIT" returns to the main riding display.

### **⚠ WARNING**

**For all setting procedures, be sure to stop the bicycle and perform the required settings in a safe location. Otherwise, lack of attention to surrounding traffic or other hazards could cause an accident.**

### **TIP**

- The settings cannot be adjusted while riding.
- If you do the following during setting, the item that you are setting will be canceled and the display will return to the main riding display.
  - Turning the crank (pedal) in the traveling direction
  - Turning the rear wheel at 1.2 mph (2 km/h) and more
  - Pushing the pushing assist switch

[S---].... Press the function select switch for 2 seconds or longer

[S]..... Press the function select switch

[▲]..... Press the assist mode switch (up)

[▼]..... Press the assist mode switch (down)

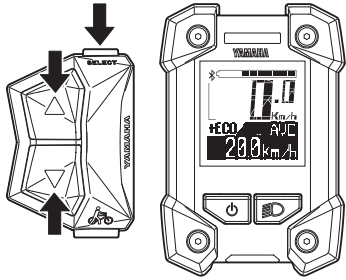

## ● STOPWATCH

The stopwatch counts time in seconds up to a maximum of 9 hours 59 minutes 59 seconds.

If this maximum is reached, it will automatically start over from 0 (zero) and continue counting.

- TIME MEASUREMENT

Use the function select switch to start and stop time measurement.

Press the function select switch for 2 seconds or longer to “RESET” the measured time.

- RESET

When the function select switch is pressed, the measured time will be reset and the measuring display will be shown.

Use the assist mode switches (up & down) to go to the “EXIT” display.

- EXIT

When the function select switch is pressed, the display will return to the main riding display.

Use the assist mode switches (up & down) to go to the “RESET” display.

### TIP

- It is possible to return to the main riding display without interrupting time measurement.
- When the power is turned off, the measured time will be reset.

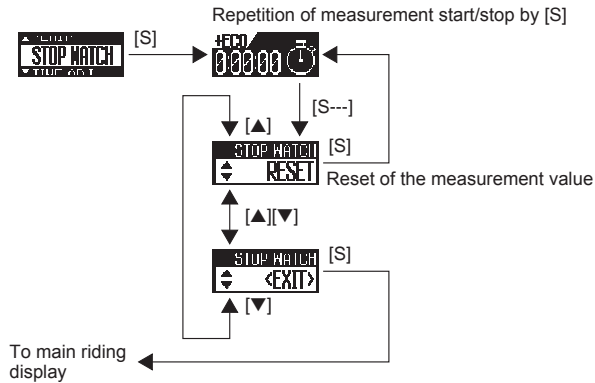

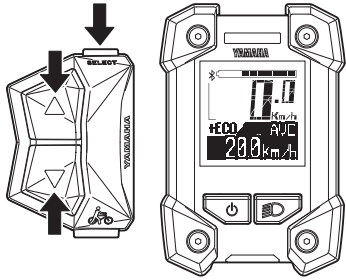

## ● TIME ADJ (TIME ADJUST)

You can adjust the time of the clock.

1. Check that the “Hour” is flashing and adjust the hour by using the assist mode switches (up & down).
2. Press the function select switch to adjust the minutes.
3. Check that the “Minute” is flashing and adjust the minutes by using the assist mode switches (up & down).
4. Press the function select switch to return to the main riding display.

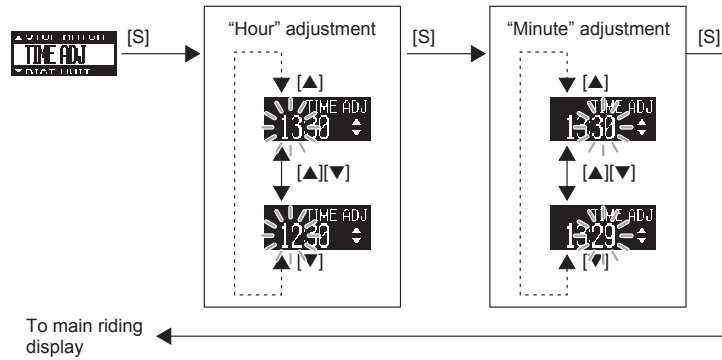

## ● DIST UNIT (DISTANCE UNIT)

You can select the display units for distance and speed. When “km” is selected, the travelled distance will be indicated in kilometers and the speed in km/h. When “mile” is selected, the travelled distance will be indicated in miles and the speed in mph.

1. Select “km” or “mile” by using the assist mode switches (up & down).
2. Press the function select switch when the desired unit is indicated in the display. This setting will then be kept and the display will return to the main riding display.

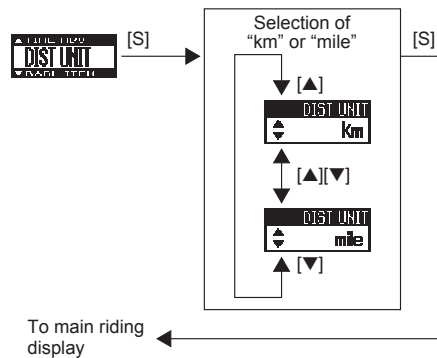
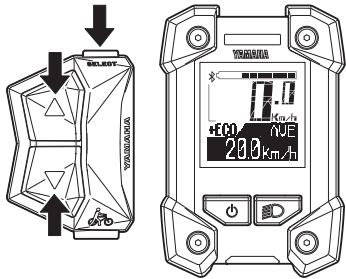

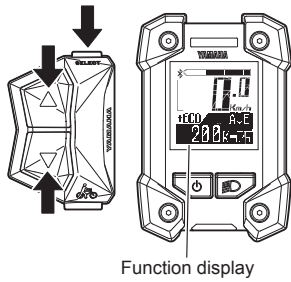

## ● DSPL ITEM (DISPLAY ITEM)

You can select to show or hide different items in the function display during normal riding.

The items which you can select to show or hide are: TRIP (trip meter), AVE (average bicycle speed), MAX (maximum bicycle speed), RANGE (remaining assist distance), BATTERY (battery capacity (%)), CADENCE (cadence), and TIME (clock).

### TIP

You cannot hide the odometer indication.

1. Select an item by using the assist mode switches (up & down).
2. Use the function select switch to show or hide the selected item. (When an item is shown, a check mark will be shown in the check box.)
3. When you press the function select switch in the "EXIT" display, the setting will be kept and the display will return to the main riding display.

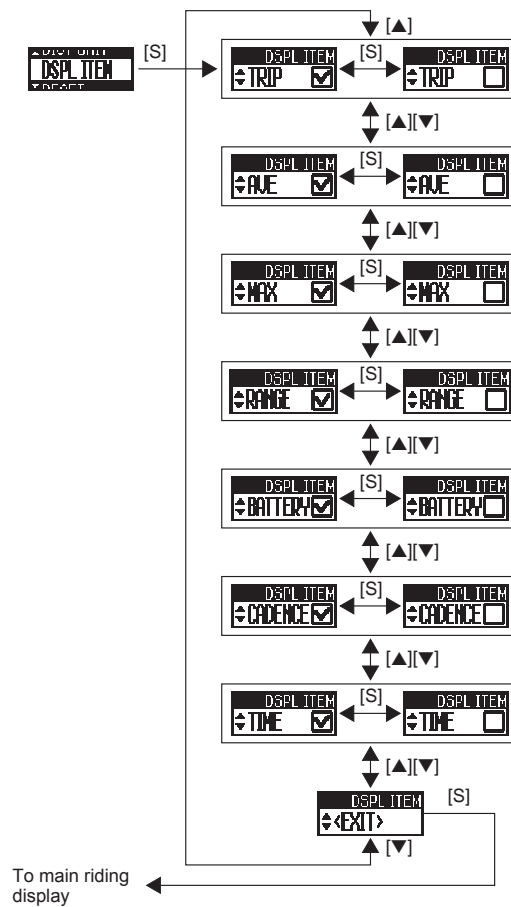



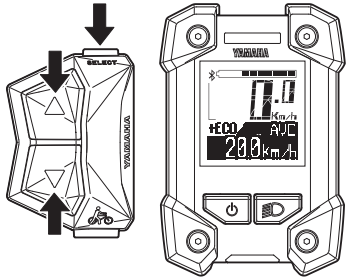

## ● RESET

You can reset the TRIP (trip meter), AVE (average bicycle speed), and MAX (maximum bicycle speed) values.

### TIP

You cannot reset the odometer.

1. Select an item by using the assist mode switches (up & down) and use the function select switch to place a check mark in the check box for the item that you want to reset.
2. When you press the function select switch in the “EXIT” display, the items with check marks will be reset and the display will return to the main riding display.

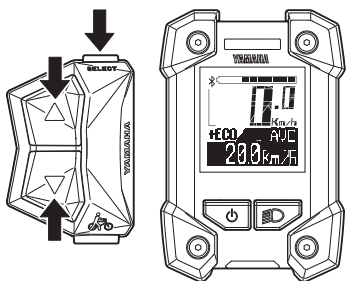
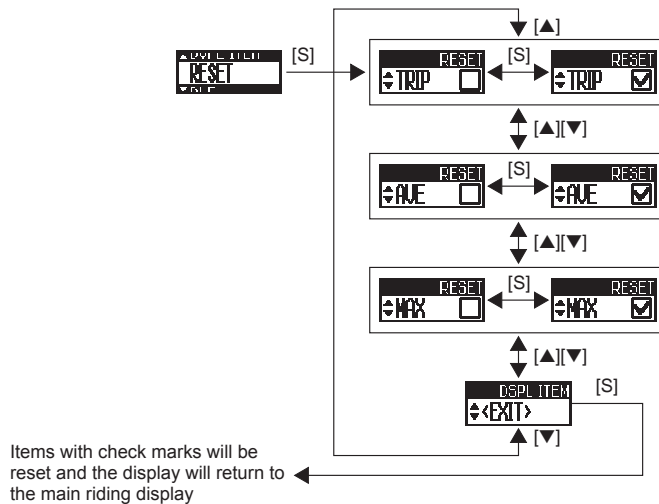

## ● BLE (Bluetooth low energy technology)

You can set the profile to use the wireless function with Bluetooth low energy technology, or you can select not to use the wireless function.

When “CSCP” is selected, the Cycling Speed and Cadence Profile will be available.

When “CPP” is selected, the Cycling Power Profile will be available.

When “OFF” is selected, the wireless function will be inactive.

### TIP

- Set the profile according to the wireless communication equipment that communicates via Bluetooth low energy technology.
- For the output power level of each profile, see “Specifications”.
- Even if the power is turned off, the setting will be kept. When the power is turned on the next time, the last used setting will be selected.

1. Select “CSCP”, “CPP”, or “OFF” by using the assist mode switches (up & down).
2. When you press the function select switch at the desired item display, the setting will be kept and the main riding display will be shown.

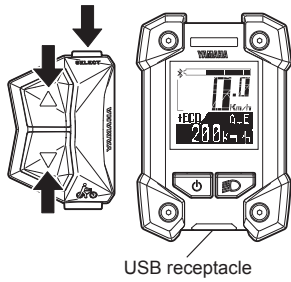
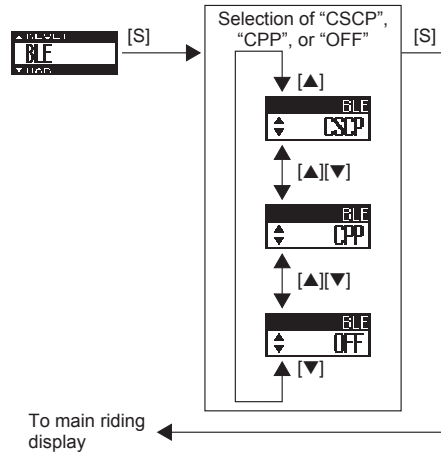

### ● USB

You can use the USB receptacle as a power supply.

### TIP

- Normally you should not use “COMM” because this is a service mode used for wired communication.
- When the power is turned off, the mode automatically changes to “PWR SPLY”.

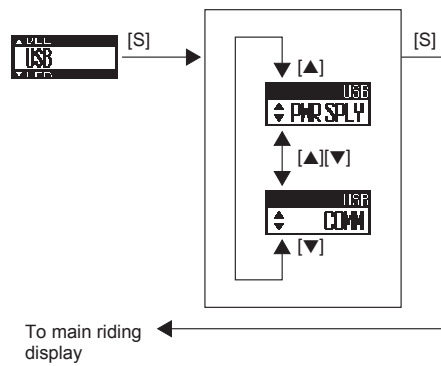

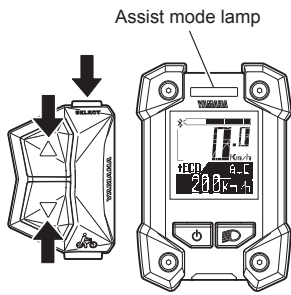

## ● LED

You can select to light up the assist mode lamp according to the assist mode or keep the assist mode lamp unlit all the time.

When “ON” is selected, the assist mode lamp will light up according to the assist mode.

When “OFF” is selected, the assist mode lamp will remain unlit all the time.

## TIP

Even if the assist mode lamp is set to “OFF”, it will light up in red if an error occurs.

1. Select “ON” or “OFF” by using the assist mode switches (up & down).
2. When you press the function select switch at the desired item display, the setting will be kept and the main riding display will be shown.

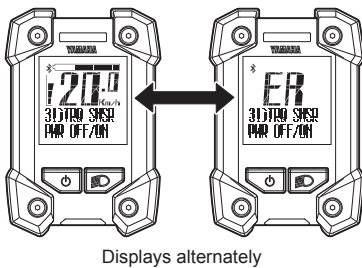
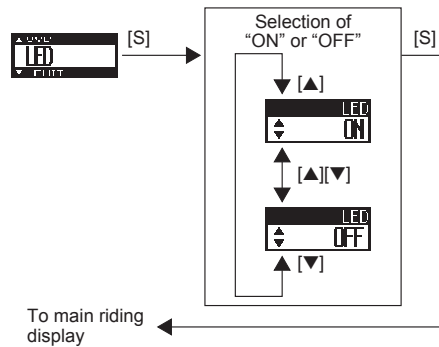

## ○ Diagnosis mode

The e-Bike Systems are equipped with a diagnosis mode. If a malfunction or fault occurs in the e-Bike Systems, the assist mode lamp will light up in red, and the main riding display and “ER” will be shown alternately, while an error description will inform you of the type of error in the function display. See “Troubleshooting” regarding symptoms and remedies for abnormal displays and abnormal flashing.

## ! WARNING

If the problem cannot be solved, have your bicycle inspected by a dealer as soon as possible.

## TIP

Even if the assist mode lamp is set to “OFF”, it will light up in red if a malfunction or fault occurs.

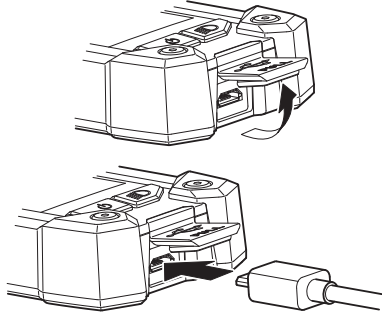

### ○ Power supply to external devices

Power can be supplied to most external devices (e.g. various smart phones etc.) by connecting a commercial USB 2.0 OTG cable.

[To supply power]

1. Open the USB receptacle cap of the display.
2. Connect the USB cable to the display and external device.
3. Turn on the power of the vehicle.

[To stop the power supply]

1. Turn off the power of the vehicle.
2. Disconnect the USB cable and put on the cap of the USB receptacle.

### **NOTICE**

- Do not apply unreasonable force on the USB plug or pull the USB cable.
- Check that the USB plug is facing the right way and not totally out-of-position with the USB receptacle or slanted, and make sure it is fully inserted all the way in.
- Do not connect the USB receptacle and the USB plug in a wet state.
- Use a USB 2.0 OTG cable that conforms to the standards.
- Do not insert foreign objects into the USB receptacle unit.

Otherwise the display unit and external device may malfunction.

### **TIP**

- Power is supplied automatically when an external device is connected with the USB cable.
- No power is supplied if the remaining capacity of the battery pack is low.
- The power supply of the vehicle will go off and power supplied by the USB connection will also stop if the vehicle is not operated for 5 minutes.

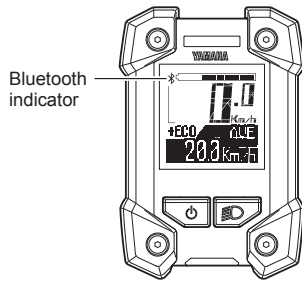

## ○ Communication with Bluetooth low energy technology

The wireless equipment corresponding to the CSCP or CPP profiles can provide the communication via Bluetooth low energy technology.

1. Set the profiles of the display unit by referring to “Stopwatch and settings”.  
Also confirm that they are in accordance with the connection settings of your wireless communication equipment.
2. Check that the Bluetooth indicator is displayed.
3. Select “Yamaha #####” from the user menu of your wireless communication equipment.  
For more information, see the instruction manual of the wireless communication equipment.

\* “#####” of “Yamaha #####” is a combination of irregular alphanumeric characters.

### TIP

- Keep the distance between the display and wireless communication equipment within 1 m. The maximum communication distance of this equipment is 1 m.  
If the wireless communication equipment is kept in a bag, etc., the actual communication distance might be shorter.
- Do not use the equipment in places with magnetic fields, static electricity, or electromagnetic interference.  
If the equipment is used near transmitters, broadcasting stations or the following type of equipment, wireless communication may not be possible.
  - Microwave ovens
  - Digital cordless phones
  - Wireless communication devices
  - Near other wireless equipment using the 2.4 GHz band.
- Do not cover the display with objects such as aluminum sheets that block the radio waves. Otherwise, wireless communication may not be possible.
- For the output power level of each profile, see the “Specifications”.

## G. Battery pack and charging procedure

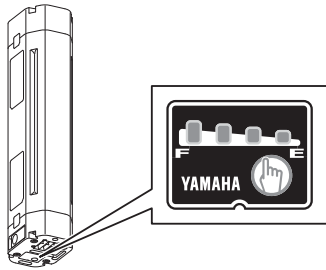
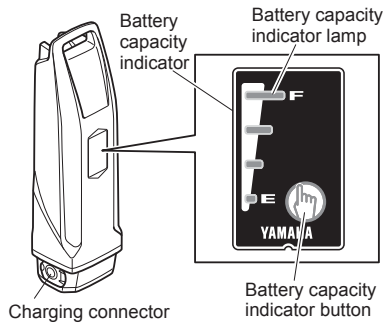
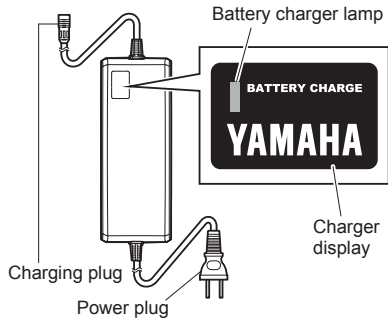

The battery pack equipped for the Yamaha e-Bike Systems is a lithium-ion battery. The lithium-ion battery is lightweight and offers superior capacity. However, it does have the following characteristics.

- Its performance decreases in extremely hot or cold environments.
- It naturally loses its charge.

The battery pack for the Yamaha e-Bike Systems also has an embedded computer which notifies you of estimated residual battery capacity and suspected faults via the battery capacity indicator lamp.

By pressing the battery capacity indicator button, you can display the residual battery capacity for approximately 5 seconds.

See “Checking the residual battery capacity” for the estimate of the residual battery capacity. See “Troubleshooting” for information on fault flashing.

### **! WARNING**

**Do not use any other charger or charging method to recharge the special batteries. Using any other charger could result in fire, explosion, or damage the batteries.**

### **! WARNING**

**IMPORTANT SAFETY INSTRUCTIONS — SAVE THESE INSTRUCTIONS  
TO REDUCE THE RISK OF FIRE OR ELECTRIC SHOCK, CAREFULLY FOLLOW THESE INSTRUCTIONS**

This manual contains important safety and operating instructions for battery charger Type PASC4.

**Before using battery charger, read all instructions and cautionary markings on battery charger, battery and product using battery.**

**Only use it to charge PASB4 type batteries for Yamaha e-Bike Systems. Other types of batteries may burst causing injury to persons and damage.**

### **NOTICE**

**Do not apply grease on the terminal of the battery.**

## **NOTICE**

This battery charger has been tested and found to comply with the limits for a Class B digital device, pursuant to part 15 of FCC Rules.

These limits are designed to provide reasonable protection against harmful interference in a residential installation.

This equipment generates, uses and can radiate radio frequency energy and, if not installed and used in accordance with the instructions, may cause harmful interference to radio communications.

However, there is no guarantee that interference will not occur in a particular installation.

If this equipment does cause harmful interference to radio or television reception, which can be determined by turning the equipment off and on, the user is encouraged to try to correct the interference by one or more of the following measures;

- Reorient or relocate the receiving antenna.
- Increase the separation between the equipment and receiver.
- Connect the equipment into an outlet on a circuit different from that to which the receiver is connected.
- Consult the dealer or an experienced radio/TV technician for help.

This device complies with Canadian ICES-001.

This device complies with part 15 of the FCC Rules. Operation is subject to the following two conditions (1) this device may not cause harmful interference, and (2) this device must accept any interference received, including interference that may cause undesired operation.

Changes or modifications not expressly approved by the party responsible for compliance could void the user's authority to operate the equipment.

## **Appropriate charging environments**

For safe and efficient charging, use the battery charger in a location that is:

- Flat and stable (when on the bicycle)
- Free of rain or moisture
- Out of direct sunlight
- Well-ventilated and dry
- Not accessible to children or pets
- Temperature between 59–77 °F (15–25 °C)

## Inappropriate charging environments and solutions

The hot and cold environments described below can cause charging to enter standby or suspension without fully charging the battery.

- **Summertime charging standby/suspension**

If charging in a location receiving direct summer sunlight or immediately after riding, the battery charger might enter charging standby (all four battery capacity indicator lamps flash slowly). See “Reading the charging status for battery pack”. This is to automatically stop charging in order to protect the battery from exceeding the specified temperature while charging. You can avoid charging suspension by starting to charge with the battery cold or at a room temperature of 59–77 °F (15–25 °C). If charging suspension occurs, move the battery charger to a cool location to reduce the charging standby time.

- **Wintertime charging standby/suspension**

Charging standby will occur if the temperature is less than 32 °F (0 °C). If charging is started and the temperature drops below this level due to late-night cooling or other factors, charging is suspended and standby mode is entered to protect the battery. In such cases, restart charging at an indoor location with a temperature of 59–77 °F (15–25 °C).

- **Noise on televisions/radios/computers**

Charging next to televisions, radios, or similar appliances might cause static, flickering images, and other interference. If this occurs, recharge in a location further away from the television or radio (such as in another room).

### **⚠ WARNING**

**If a charging fault occurs during charging, remove the power plug of the battery charger from the socket and wait for the battery pack/battery charger to cool.**

## Charging the battery pack mounted on the bicycle (Down tube type)

1. Connect the power plug of the battery charger to a household power outlet.
2. Remove the cap of charging inlet from the charging connector on the battery pack, and connect it to the charging plug on the battery charger.

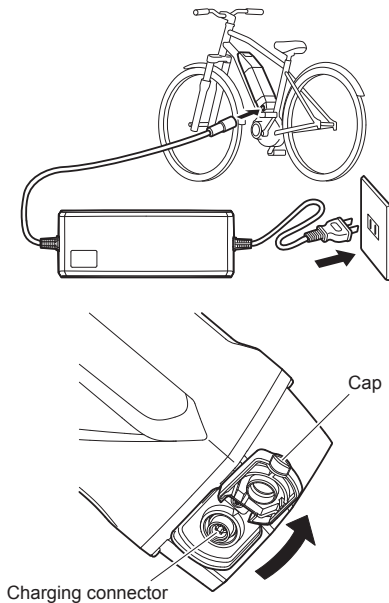



## Charging the battery pack mounted on the bicycle (Multi location type)

1. Connect the power plug of the battery charger to a household power outlet.
2. Remove the cap of charging inlet from the charging connector on the bicycle, and connect it to the charging plug on the battery charger. How to open the cap varies between bicycles.

### NOTICE

- **Do not connect the charging plug of the battery charger with the charging connector of the battery in a wet state.**
- **Be sure to connect the charging plug only after the charging connector on the battery pack is completely dry.**  
**Otherwise the battery charger and battery pack may malfunction.**
- **Do not apply excessive force to the charging plug or pull on the cord with the charging plug connected to the battery.**  
**Otherwise, the plug or connector may be damaged.**
- **Do not pedal while the charging plug is connected.**

3. See “Reading the charging status for battery pack”, and check that the battery charger is charging the battery pack.
4. The battery capacity indicator lamps will light up one by one until all four are on. Then, when charging is complete, all of the lamps will go off.

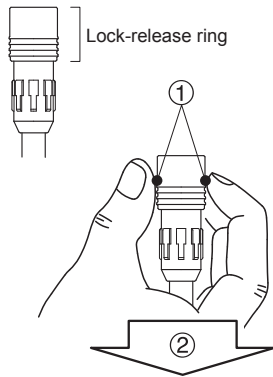

5. Confirm that charging is complete, and then disconnect the charging plug from the battery pack.  
How to disconnect the plug (see the left figure)
  - ① Grasp the lock-release ring.
  - ② Pull it out straight.
6. Place the cap of charging inlet on the battery pack's charging connector.

#### **! WARNING**

**Never handle the power plug, charging plug or touch the charger contacts with wet hands. This could result in electric shock.**

#### **TIP**

- Charging will start automatically.
- If the display unit is turned on while the battery pack is charging, all normal displays will be shown, including the battery capacity indicator, but the assist system will not function.
- When the battery pack is connected to the battery charger, the battery charger lamp will flash at approximately 0.2 second intervals to indicate that the battery pack is being prepared to be charged. Leave it alone and charging will start normally.

### **Charging the battery pack removed from the bicycle**

1. Turn the display unit off.
2. Insert the key into the battery lock, and turn it to release the battery lock.
3. Remove the battery pack.

#### **! WARNING**

**Use both hands when removing the battery pack. Do not drop the battery pack or subject it to impact. Doing so could cause the battery pack to become hot or catch fire, resulting in serious injury or property damage.**

#### **TIP**

How to remove Multi location type battery packs varies between bicycles. For more information, see the instruction manual supplied with the bicycle.

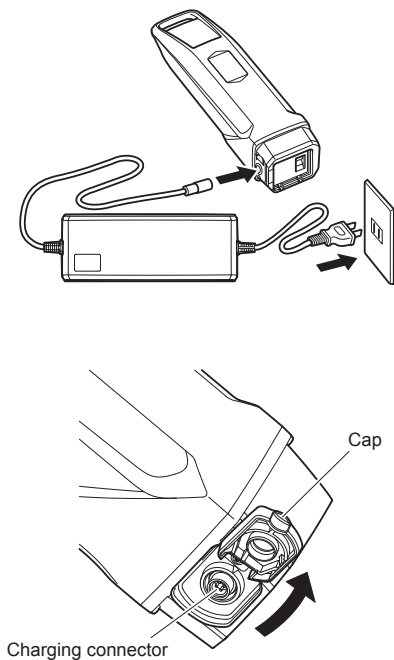

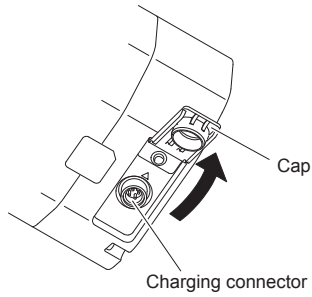
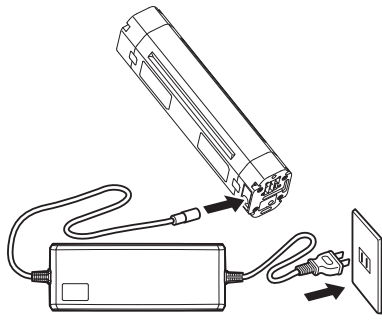

4. Connect the power plug of the battery charger to a household power outlet.
5. Remove the cap from the charging connector on the battery pack, and connect it to the charging plug on the battery charger.

#### **NOTICE**

- Do not connect the charging plug of the battery charger with the charging connector of the battery pack in a wet state.
- Be sure to connect the charging plug only after the charging connector on the battery pack is completely dry.

Otherwise the battery charger and battery pack may malfunction.

- Do not apply excessive force to the charging plug or pull on the cord with the charging plug connected to the battery pack.

Otherwise, the plug or connector may be damaged.

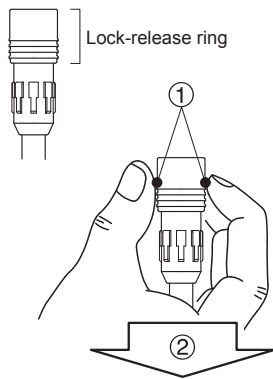

6. See “Reading the charging status for battery pack”, and check that the battery charger is charging the battery pack.
7. The battery capacity indicator lamps will light up one by one until all four are on. Then, when charging is complete, all of the lamps will go off.
8. Confirm that charging is complete, and then disconnect the charging plug from the battery pack.  
How to disconnect the plug (see the left figure)
  - ① Grasp the lock-release ring.
  - ② Pull it out straight.
9. Place the cap on the battery pack’s charging connector.
10. Mount the battery pack on the bicycle.

### **⚠ WARNING**

- **Do not touch charger contacts with metallic objects. Do not allow foreign material to cause short circuit of the contacts. This could result in electric shock, fire, or damage the battery charger.**
- **Periodically remove dust from the power plug. Dampness or other issues could reduce the effectiveness of the insulation, resulting in fire.**
- **Never disassemble or modify the battery charger. This could result in fire or electric shock.**
- **Do not use with a power strip or extension cord. Using a power strip or similar methods may exceed rated current and can result in fire.**
- **Do not use with the cable tied or rolled up, and do not store with the cable wrapped around the charger main body. Cable damage can result in fire or electric shock.**
- **Firmly insert the power plug and the charging plug into the socket. Failure to insert the power plug and the charging plug completely can result in fire caused by electric shock or overheating.**
- **Do not use the battery charger near flammable material or gas. This could result in fire or explosion.**
- **Never cover the battery charger or place other objects on top of it while charging. This could result in internal overheating leading to fire.**

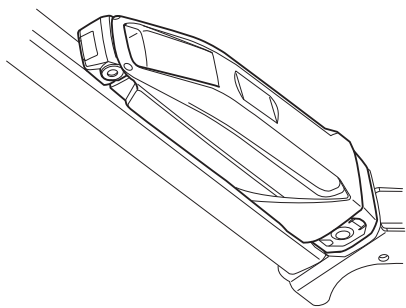
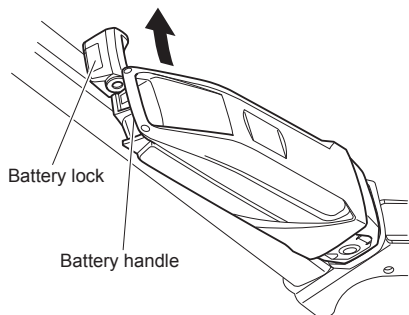
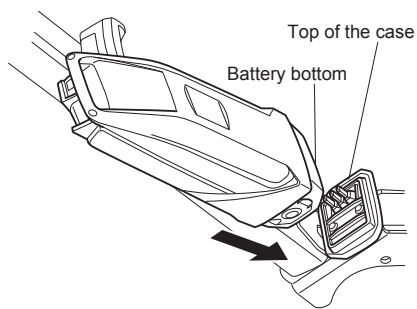

#### TIP

##### Battery pack mounting method (Down tube type)

- Insert the battery in the direction of the arrow so that the battery bottom is aligned to the top of the case.
- Insert the upper part of the battery in the direction of the arrow so that the battery handle is aligned to the top of the battery lock.
- Press the upper part of the battery toward the frame until it clicks into place to secure it.

#### TIP

How to install Multi location type battery packs varies between bicycles. For more information, see the instruction manual supplied with the bicycle.

11. Make sure that it is securely attached by pulling the battery pack after installation.







#### **! WARNING**

- Do not short the contacts of the battery pack. Doing so could cause the battery pack to become hot or catch fire, resulting in serious injury or property damage.
- Do not disassemble or modify the battery pack. Doing so could cause the battery pack to become hot or catch fire, resulting in serious injury or property damage.
- Do not dispose of the battery pack in a fire or expose it to a heat source. Doing so could cause an explosion, resulting in serious injury or property damage.
- Do not drop the battery pack or subject it to impact. Doing so could cause the battery pack to become hot or catch fire, resulting in serious injury or property damage.



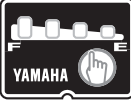

#### **NOTICE**

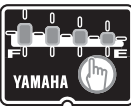
Make sure there is no foreign matter on the battery pack contacts before inserting the battery pack.

## Reading the charging status for battery pack

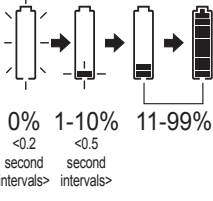
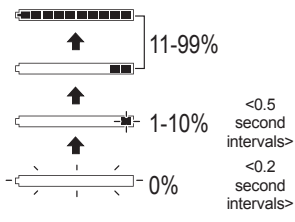
Battery charger lamp	Battery capacity indicator lamps		Current status	Details
	(Down tube type)	(Multi location type)		
 On	 	(Example: Battery is approximately 50–75 % charged.)	Charging	During charging, the battery capacity indicator lamps light up one by one.
 Off	  Off		Charging completed	When charging is complete, the charging lamp on the battery charger and the battery capacity indicator lamp on the battery pack go off.
	 	Four lamps flash simultaneously.	Battery is in standby mode. * The battery internal temperature is too high or too low.	Charging will automatically restart when a temperature is reached that allows charging. (See “Appropriate charging environments”.)  When possible, always perform charging at the optimal temperature of 59–77 °F (15–25 °C).

## Reading the charging status for display unit (Applies only to models equipped with the Multi location type battery pack.)

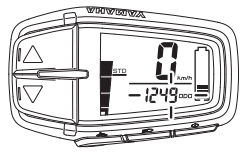
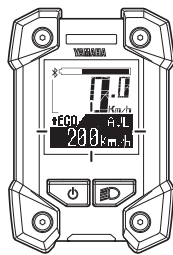
Battery charger lamp	Display unit		Current status	Details
	(Display A)	(Display X)		
	 <p>0% &lt;0.2 second intervals&gt; 1-10% &lt;0.5 second intervals&gt; 11-99%</p>	 <p>11-99% 1-10% &lt;0.5 second intervals&gt; 0% &lt;0.2 second intervals&gt;</p>	Charging	The battery capacity indicator slowly increases.
	<p>All segments of the battery capacity indicator light up.</p> 	<p>All segments of the battery capacity indicator light up.</p> 	Charging completed	When charging is complete, all segments of the battery capacity indicator of the drive unit will go off and the battery charger lamp of the charger will go out.
	<p>All function display items are flashing.</p> 	<p>All function display items are flashing.</p> 	Battery is in standby mode. * The battery internal temperature is too high or too low.	<p>Charging will automatically restart when a temperature is reached that allows charging. (See "Appropriate charging environments".)</p> <p>When possible, always perform charging at the optimal temperature of 59–77 °F (15–25 °C).</p>

## TIP

For example, even if normal charging is started, if the battery temperature or the surrounding temperature is too high or too low, the charging may be extended or charging may be stopped without the battery being charged sufficiently in order to protect the battery.

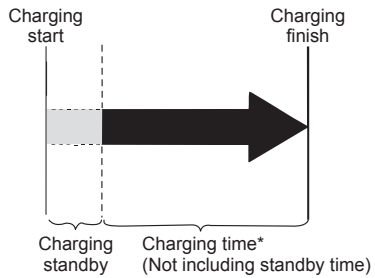

## Charging time guidelines

Although charging time varies depending on residual battery capacity and external temperature, if the battery has been exhausted, it generally takes approximately 3.5 hours (Down tube type 400 Wh), 4 hours (Down tube type 500 Wh) or 5 hours (Multi location type 600 Wh).

If the battery pack enters standby mode while charging, charging time will increase by an equal amount.

\* If charging after a long period of disuse, the charging time will be lengthened depending on the battery status. However, note that if the battery capacity indicator lamps do not flash in fault pattern (See "Reading the charging status for battery pack"), there is no malfunction.



## H. Checking the residual battery capacity



You can check the estimate of how much capacity is left in the battery and to what extent it is charged. The check can be performed using either the display unit's residual battery capacity indicator or the battery's residual battery capacity indicator lamps.

### TIP

- Even if the battery's capacity reaches 0 (zero), you can still ride the bicycle as a regular bicycle.
- If you are using an old battery pack, the residual battery capacity indicator may suddenly display very little power when you start moving. This is not a malfunction. Once riding stabilizes and the load is reduced, the proper value is displayed.





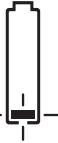
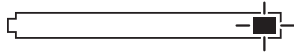
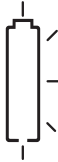
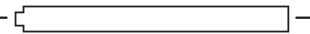



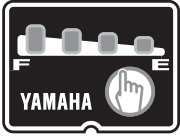

## Residual battery capacity indicator display and estimate of residual battery capacity for display unit

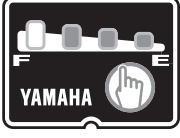
The residual battery capacity can be displayed as a numerical value on the display unit.

Display of the residual battery capacity for the display unit (Display A)                      (Display X)		Display of the residual battery capacity	Applicable situation
		100–11 %	When you turn on the power of the display unit and ride continually after the battery is fully charged, the segments for the residual battery capacity indicator go out one by one each time the residual battery capacity is reduced by 10 %.
		10–1 %	There is very little residual battery capacity left. Please charge the battery soon.
		0 %	There is no more residual battery capacity. Turn off the power for the display unit and charge the battery pack soon. * Assist is stopped, but you can still ride the bicycle as a regular bicycle.

## Display of the battery capacity indicator lamps and the estimate of the residual battery capacity

When checking the residual battery capacity, push the battery capacity indicator button “”.

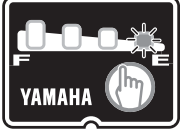
Display of the battery capacity indicator lamps		Estimate of the residual battery capacity	Applicable situation
(Down tube type)	(Multi location type)		
		100–76 %	From full charge (100 %), the battery capacity indicator lamps turn off, one by one.
		75–51 %	
		50–26 %	
		25–11 %	
		10–1 %	
		0 %	The battery capacity has reached 0 (zero). Please charge the battery pack.

Slow flashing  
<0.5 second intervals>

Fast flashing  
<0.2 second intervals>

## I. Pre-operation check

### **⚠ WARNING**

Be sure to perform the inspection before riding the bicycle.  
If there is anything you do not understand or find difficult, please consult a bicycle dealer.

### **NOTICE**

- If you confirm there is a fault, have your bicycle inspected at a dealer as soon as possible.
- The power assist mechanism consists of precision parts. Do not disassemble it.

Along with performing the regular inspection before riding the bicycle, also perform the following inspections.

No.	Inspection item	Inspection contents
1	Residual battery capacity	Is enough capacity left in the battery?
2	Installation status of the battery pack	Is it properly installed?
3	Operation of the e-Bike Systems	Do the e-Bike Systems operate when you begin moving?

## J. Cleaning, maintenance and storage

### **NOTICE**

Do not use high-pressure washers or steam jet cleaners since they can cause water seepage, resulting in property damage or malfunction of the Drive Unit or display unit or battery pack. Should water get inside one of these units, have an authorized dealer inspect your bicycle.

### Caring for the battery pack

Use a moist, tightly-wrung towel to wipe off dirt on the battery pack. Do not pour water directly on the battery pack, such as with a hose.

### **NOTICE**

Do not clean the contacts by polishing them with a file or using a wire, etc. Doing so could result in a fault.

### Maintenance for the Drive Unit

### **NOTICE**

Because a Drive Unit is a precision machinery, do not disassemble or exert any strong force on it (for example, do NOT hit this product with a hammer). Especially since the crank axle is directly connected to the inside of the Drive Unit, any large damages inflicted on the crank axle may lead to failures.

## Storage

Store the system in a place that is:

- Flat and stable
- Well ventilated and free from moisture
- Sheltered from the elements and from direct sunlight

## Long storage period (1 month or longer) and using it again after a long storage period

- When storing the bicycle for a long period (1 month or longer), remove the battery pack and store it using the following procedure.
- Decrease the residual battery capacity to where one or two battery capacity indicator lamps are lit, and store it indoors in a cool 59–77 °F (15–25 °C), dry place.
- Check the residual battery capacity once a month, and if only one battery capacity indicator lamp is flashing, charge the battery pack for about 10 minutes. Do not let the residual battery capacity become too low.

### TIP

- If you leave the battery pack at “full charge” or “empty”, it will deteriorate quicker.
  - Due to self-discharge, the battery slowly loses its charge during storage.
  - The battery’s capacity decreases over time but proper storage will maximize its service life.
- 
- When using it again after a long storage period, be sure to charge the battery pack before using it. Also, if you are using it again after storing it for 6 months or longer, have your bicycle inspected and maintained at a dealer.

## K. Transport

The batteries are subject to the Dangerous Goods Legislation requirements. When being transported by third parties (e.g. via air transport or forwarding agency), special requirements on packaging and labels must be observed. To prepare the item for shipping, consult a hazardous materials expert. The customer can transport the batteries by road without further requirements. Do not transport damaged batteries.

Tape or mask off open contacts and pack up the battery pack in such a manner that it cannot move around in the packaging. Be sure to observe all local and national regulations. In case of questions concerning transport of the batteries, please refer to an authorized bicycle dealer.

## L. Consumer information

### Disposal

The Drive Unit, battery pack, battery charger, display unit, speed sensor set, accessories and packaging should be sorted for environmental-friendly recycling.

Do not dispose of the bicycle or its components as household waste.

#### **WARNING**

**Do not dispose of the battery pack in a fire or expose it to a heat source. Doing so could cause fire, or explosion, resulting in serious injury or property damage.**



You may recycle your battery pack by calling 1-800-822-8837.





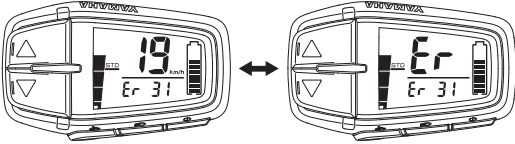
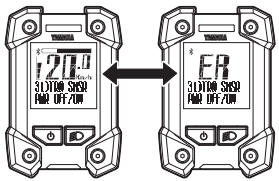

## M. Troubleshooting

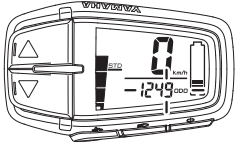

### E-Bike Systems

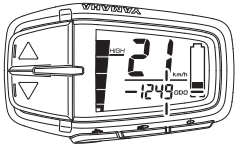
Symptom	Check	Action
<b>Pedaling is difficult.</b>	Is the display unit's power on?	<b>Press the power switch on the display unit to turn the power on.</b>
	Is the battery pack installed?	<b>Install a charged battery pack.</b>
	Is the battery pack charged?	<b>Charge the battery pack.</b>
	Has the bicycle remained stationary for 5 minutes or longer?	<b>Turn the power on again.</b>
	Are you riding on a long inclined road or carrying a heavy load during summertime?	<b>This is not a malfunction. It is a safeguard engaged when the temperature of the battery pack or the Drive Unit is too high. Power assist will be restored once the temperature of the battery pack or the Drive Unit has decreased. Also, you can make this less likely to occur by shifting to a lower gear than you would usually use (for example, by shifting from second to first gear).</b>
	Is the air temperature low (roughly 50 °F (10 °C) or below)?	<b>During the wintertime, store the battery pack indoors before use.</b>
	Are you charging the battery pack while it is mounted on the bicycle?	<b>Stop charging the battery pack.</b>

Symptom	Check	Action
The Drive Unit turns on and off while riding.	Is the battery pack correctly installed?	Check to make sure the battery pack is locked in place. If this problem still occurs with the battery pack firmly locked in place, there may be a loose connection with the battery pack terminals or wires. Have an authorized dealer inspect your bicycle.
Strange rumbling or crunching noises come from the Drive Unit.		There could be a problem inside the Drive Unit. Have an authorized dealer inspect your bicycle.
Smoke or unusual odor comes from the Drive Unit.		There could be a problem inside the Drive Unit. Have an authorized dealer inspect your bicycle.
<p>(Display A) The main riding display and “Er” are displayed alternately, and an error description is indicated in the function display.</p>  <p>(Display X) The assist mode lamp lights up in red, the main riding display and “ER” are displayed alternately, and an error description is indicated in the function display.</p>  <p>Displays alternately</p>  <p>Error displays</p>		<p>The problem occurs in the e-Bike Systems. Turn off the power and then turn it on again. If the problem cannot be solved, have your bicycle inspected by a dealer as soon as possible.</p>

Symptom	Check	Action
Traveling range has decreased.	Are you fully charging the battery pack?	Charge the battery pack until full (F).
	Are you using the system under low-temperature conditions?	Normal traveling range will be restored when the ambient temperature rises. Additionally, storing the battery pack indoors (in a warm location) before use will improve traveling range under cold conditions.
	Is the battery pack worn out?	Replace the battery pack.
<p>(Display A) The speed is not displayed even while riding, and the function display is flashing.</p>  <p>(Display X) An assist mode lamp lights up in red and an error description is indicated in the function display.</p>  <p>Error displays</p>		<p>The speed sensor cannot detect a correct signal. Turn off the power to the display unit and then turn it on again. Select the assist mode and then ride for a short distance. Also, make sure the magnet is mounted correctly on the spokes of the wheels.</p>
<p>(Display A) The speed is displayed but the function display is flashing. (Power assist is stopped.)</p>  <p>(Display X) The assist mode indicator and function display are flashing. (Power assist is stopped.)</p> 		<p>This is not a malfunction. It is in a state that the operation of the power assist system is normal. This state may occur depending on the pedaling strength and riding speed, but it returns to normal condition if it is confirmed that the system is normal.</p>

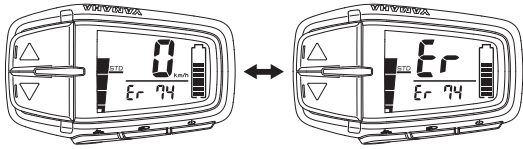
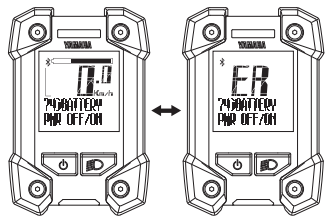
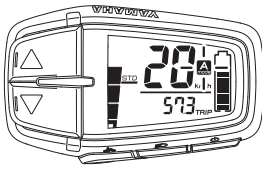

Symptom	Check	Action
<p><b>(Display A)</b> The main riding display and “Er” are displayed alternately, and an error description is indicated in the function display.</p>  <p><b>(Display X)</b> The assist mode lamp will light up in red, and the main riding display and “ER” are displayed alternately, and an error description is indicated in the function display.</p> 		<p>The problem occurs in the battery pack. Turn off the power and then turn it on again. If the problem cannot be solved, have your battery pack inspected by a dealer as soon as possible.</p>
<p><b>(Display A)</b> The Automatic mode indicator is flashing.</p>  <p><b>(Display X)</b> “A:####” and “####” on the assist mode indicator are alternately displayed.</p>  <p>For example, in the case of Standard mode</p>		<p>There could be a problem inside the Drive Unit. Turn off the power to the display unit and then turn it on again. If the problem cannot be solved, have your bicycle inspected by a dealer as soon as possible.</p>

## Power supply of external devices via USB connection

\*Applies only to the Display X.

Symptom	Check	Action
<b>Power is not supplied.</b>	Is the display unit's power on?	<b>Press the power switch on the display unit to turn the power on.</b>
	Is the USB version correct?	<b>Use an external device that complies with USB 2.0.</b>
	Is the USB cable type correct?	<b>Use an OTG cable. Also connect the host side to the display.</b>
	Is the USB cable firmly connected?	<b>Re-connect the USB cable.</b>
	Is the USB receptacle or USB plug terminal dirty or wet?	<b>Disconnect the USB cable from the display unit and external device. Remove the dirt and water on the USB receptacle and USB plug terminal and re-connect the cable.</b>
	Is USB setting set to "COMM"?	<b>Set the USB settings to "PWR SPLY" by referring to "Stopwatch and settings" or turn off the power and then turn it on again.</b>



## Wireless communication with Bluetooth low energy technology

\*Applies only to the Display X.

Symptom	Check	Action
Wireless communication cannot be used.	Are both the wireless communication settings of the display unit and your wireless communication equipment turned on?	Set the communication profiles by referring to “Stopwatch and settings”, and then set the correct communication profiles of the wireless equipment or application software.
	Are the communication profiles of the wireless equipment or application software that communicates wirelessly with the communication profiles of the display correct?	
The display values of the external wireless communication equipment are wrong.	Did you change the settings of the communication profiles?	Reset pairing for a moment, set the communication profiles of the display, and then establish pairing again. For resetting of pairing and the procedure of establishing pairing, refer to the instruction manual supplied with the wireless communication equipment.

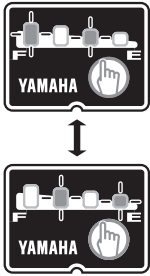
## Battery pack and charger

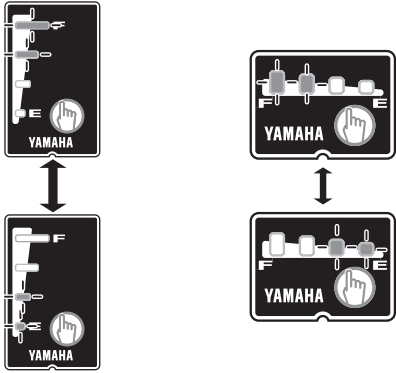
Symptom	Check	Action
Cannot charge	Is the power plug firmly connected? Is the charging plug firmly inserted in the battery pack?	<b>Reconnect and try charging again.</b> <b>If the battery pack still does not charge, the battery charger might be malfunctioning.</b>
	Are the residual battery capacity indicator lamps lit?	<b>Review charging method and try charging again.</b> <b>If the battery pack still does not charge, the battery charger might be malfunctioning.</b>
	Are the battery charger or battery pack contact terminals dirty or wet?	<b>Remove the battery pack from the battery charger and the charger plug from the socket. Use a dry cloth or cotton swab to clean the charger and battery contact terminals. Then reconnect both the battery pack and the battery charger.</b>
<p>(Down tube type)</p>  <p>(Multi location type)</p> 	There is a contact fault in the contact terminals.	<p><b>Remove the battery pack from the bicycle.</b></p> <p><b>Then connect the charging plug into the battery pack.</b> (If battery capacity indicator lamps still flash alternately, there might be a fault in the battery pack).</p> <p><b>When the battery pack is remounted on the bicycle and the power switch of the display unit is pressed, if battery capacity indicator lamps still flash alternately, there might be a fault in the Drive Unit.</b></p>

Symptom	Check	Action
<p>(Down tube type)      (Multi location type)</p> 	<p>There is a contact fault in the contact terminals.</p>	<p>Remove the battery pack from the battery charger, mount the battery on the bicycle and press the power switch of display unit. When the charging plug is reconnected into the battery pack, if battery capacity indicator lamps still flash simultaneously, there might be a fault in the battery charger.</p>
	<p>Is the charging connector on the battery pack wet?</p>	<p>Clean the charging connector and charging plug. Then dry them. Afterwards, connect the charging plug to the charging connector.</p>
<p><b>Both side battery capacity indicator lamps are flashing simultaneously.</b></p> <p>(Down tube type)      (Multi location type)</p> 		<p>The battery pack protection feature has been activated and the system cannot be used. Replace the battery pack at an authorized dealer as soon as possible.</p>
<p><b>The battery charger emits abnormal noises, foul odors or smoke.</b></p>		<p>Unplug the charger plug and immediately cease operation. Have an authorized dealer inspect your bicycle.</p>
<p><b>The battery charger becomes hot.</b></p>	<p>It is normal for the battery charger to become somewhat warm during charging.</p>	<p>If the battery charger is too hot to be touched by hand, unplug the charger plug, wait for it to cool, and consult an authorized dealer.</p>
<p><b>After charging, all of the battery capacity indicator lamps do not light up when the battery capacity indicator button “” is pressed.</b></p>	<p>Has the charger plug been unplugged or the battery pack removed during charging?</p>	<p><b>Charge the battery pack again.</b></p>
	<p>Did you start charging with the battery pack at a high temperature, such as immediately after use?</p>	<p><b>Move to a location where the battery temperature can reach the range where charging is possible (59–77 °F (15–25 °C)), and then start charging again.</b></p>

Symptom	Check	Action
<b>After disconnecting the charging plug on the battery charger from the battery pack, the battery capacity indicator lamps continue to light up.</b>	Is the charging connector on the battery pack wet?	<b>Clean the charging connector and charging plug. Then dry them.</b>

## N. Specifications

Range of assist speed		0 to less than 20 mph (32 km/h)	
Electric motor	Type		Brushless DC type
	Maximum 30 minutes power		500 W
Assist power control method		Control method depends on pedaling torque and bicycle speed	
Battery pack	Down tube type 400 Wh/500 Wh	Type	PASB4 (X0R-00)/PASB4 (X0R-10) (Lithium-ion battery)
		Voltage	36 V
		Capacity	11 Ah/13.6 Ah
		Number of battery cells	40
	Multi location type 600 Wh	Type	PASB4 (B0P-00) (Lithium-ion battery)
		Voltage	36 V
		Capacity	16.5 Ah
		Number of battery cells	50
Charger		Type	PASC4
		Input voltage	AC 100–240 V/50–60 Hz
		Maximum output voltage	DC 42 V
		Maximum output current	DC 4.0 A
		Maximum consumed power	190 W (Charged at AC 100 V)
		Applicable type battery	PASB4

Display unit (Display X)	Power supply portion	USB receptacle type	USB2.0 Micro-B
		Output current	Max. 1000 mA
		Rated voltage	5 V
	Wireless communication portion	Communication system	Bluetooth version 4.0 (Bluetooth low energy technology)
		Output power	-9.27 dBm (e.i.r.p.)
		Communication range	Line-of-sight distance approx. 1 m (3 ft) without interference
		Frequency band	2.4 GHz band (2.400–2.4835 GHz)
		Modulation method	GFSK
		Supported profiles	CSCP <sup>*1</sup> CPP <sup>*2</sup>

\*1 CSCP (Cycling Speed and Cadence Profile)

Corresponds to the wheel revolution data and crank revolution data.

\*2 CPP (Cycling Power Profile)

Corresponds to the wheel revolution data, crank revolution data, instantaneous power, and accumulated energy.

- Communication is not necessarily guaranteed with all wireless communication devices that have the same profiles as this system.  
Even when a device complies with the specification for Bluetooth low energy technology, there may be cases where the characteristics, specifications, or communicative environment of the device with this technology make it impossible to connect, or may result in different control methods, display or operation.
- YAMAHA MOTOR CO., LTD. can not be held liable in any way for damages or other loss resulting from information leaks during the communication via Bluetooth low energy technology.







PRINTED IN JAPAN