

TEST REPORT

Applicant Name & Address : Gree Electric Appliances, Inc. of Zhuhai
Jinji West Road, Qianshan, Zhuhai, Guangdong 519070, P. R. China

Sample Description
Product : Module transmitter
FCC ID : 2ADAP-CS532U
IC: : 12478A-CS532U
Model No. : CS532U
Electrical Rating : DC 3.3V

Date Received : 21 Nov., 2014

Date Test Conducted : 21 Nov., 2014 –24 Dec., 2014

Test standards : 47 CFR PART 15 Subpart C: 2013 section 15.247
RSS-210 Issue 8: December 2010
RSS-Gen Issue 4: December 2010

Test Result : Pass

Conclusion : The submitted samples complied with the above rules/standards.

Remark : None.

*****End of Page*****

Prepared and Checked By:

Approved By:

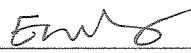

Endy Ye
Engineer
Intertek Guangzhou

 *Signature*

Helen Ma
Sr. Project Engineer
Intertek Guangzhou

08 Jan., 2015 *Date*

This report is for the exclusive use of Intertek's Client and is provided pursuant to the agreement between Intertek and its Client. Intertek's responsibility and liability are limited to the terms and conditions of the agreement. Intertek assumes no liability to any party, other than to the Client in accordance with the agreement, for any loss, expense or damage occasioned by the use of this report. Only the Client is authorized to permit copying or distribution of this report and then only in its entirety. Any use of the Intertek name or one of its marks for the sale or advertisement of the tested material, product or service must first be approved in writing by Intertek. The observations and test results in this report are relevant only to the sample tested. This report by itself does not imply that the material, product, or service is or has ever been under an Intertek certification program. The test report only allows to be revised within three years from its original issued date unless further standard or the requirement was noticed.

Intertek Testing Services Shenzhen Ltd. Guangzhou Branch
Block E, No.7-2 Guang Dong Software Science Park, Caipin Road, Guangzhou Science City, GETDD Guangzhou, China
Tel / Fax: 86-20-8213 9688/86-20-3205 7538

CONTENT

TEST REPORT	1
CONTENT	2
1.0 Summary of Test.....	3
2.0 General Description	4
2.1 Product Description.....	4
2.2 Related Submittal(s) Grants.....	5
2.3 Test Methodology.....	5
2.4 Test Facility.....	5
3.0 System Test Configuration.....	6
3.1 Justification	6
3.2 EUT Exercising Software.....	7
3.4 Measurement Uncertainty.....	7
3.5 Equipment Modification.....	7
3.6 Support Equipment List and Description.....	7
4.0 Measurement Results	8
4.1 Antenna Requirement:	8
4.2 6 dB Bandwidth and Occupied Bandwidth:.....	9
4.3 Maximum Peak Conducted Output Power and e.i.r.p.....	24
4.4 Peak Power Spectral Density.....	33
4.5 Out of Band Conducted Emissions.....	42
4.6 Out of Band Radiated Emissions.....	67
4.7 Radiated Emissions in Restricted Bands.....	68
4.8 Band Edges Requirement	108
4.9 Conducted Emission Test	114
5.0 Test Equipment List.....	117

1.0 Summary of Test

TEST	TEST REQUIREMENT	TEST METHOD	RESULT
Antenna Requirement	FCC PART 15 C section 15.247 (c) and Section 15.203 RSS-Gen clause 7.1.2	FCC PART 15 C section 15.247 (c) and Section 15.203 RSS-Gen clause 7.1.2	PASS
6 dB Bandwidth	FCC PART 15 C section 15.247 (a)(2) RSS-210 clause A8.2(a)	ANSI C63.10: Clause 6.9.1	PASS
Occupied Bandwidth	RSS-210 A8.2(a)	RSS-Gen clause 4.6.1 & ANSI C63.10: Clause 6.9	PASS
Maximum Peak Conducted Output Power and EIRP	FCC PART 15 C section 15.247(b)(3) RSS-210 A8.4(4)	ANSI C63.10: Clause 6.10.2.1 RSS-Gen clause 4.8	PASS
Peak Power Spectral Density	FCC PART 15 C section 15.247(e) RSS-210 A8.2(b)	ANSI C63.10: Clause 6.11.2.3 RSS-Gen clause 4.8	PASS
Out of Band Conducted Emissions	FCC PART 15 C section 15.209 & 15.247(d) RSS-210 A8.5	ANSI C63.10: Clause 6.7 RSS-Gen clause 4.9	PASS
Out of Band Radiated Emission	FCC PART 15 C section 15.209 & 15.247(d) RSS-210 A8.5	ANSI C63.10: Clause 6.4, 6.5 and 6.6 RSS-Gen clause 4.9	N/A
Radiated Emissions in Restricted Bands	FCC PART 15 C section 15.209 & 15.247(d) RSS-210 A8.5	ANSI C63.10: Clause 6.4, 6.5 and 6.6 RSS-Gen clause 4.9	PASS
Band Edges Measurement	FCC PART 15 C section 15.247 (d) & 15.205 RSS-210 A8.5	ANSI C63.10: Clause 6.9.2 RSS-Gen clause 4.9	PASS
Conducted Emissions at Mains Terminals	FCC PART 15 C section 15.207 RSS-Gen clause 7.2.4	ANSI C63.10: Clause 6.2	PASS

Remark:

N/A: not applicable. Refer to the relative section for the details.
 EUT: In this whole report EUT means Equipment Under Test.
 Tx: In this whole report Tx (or tx) means Transmitter.
 Rx: In this whole report Rx (or rx) means Receiver.
 RF: In this whole report RF means Radio Frequency.
 ANSI C63.10: the detail version is ANSI C63.10:2013 in the whole report.

2.0 General Description

2.1 Product Description

Operating Frequency	2412 MHz to 2462 MHz for 802.11b/g/n(HT20) 2422 MHz to 2452 MHz for 802.11n(HT40)
Type of Modulation:	802.11b: DSSS(CCK/QPSK/BPSK) 802.11g: OFDM(BPSK/QPSK/16QAM/64QAM) 802.11n: MIMO OFDM (BPSK/QPSK/16QAM/64QAM)
Transmit Data Rate:	802.11b :1/2/5.5/11 Mbps 802.11g :6/9/12/18/24/36/48/54 Mbps 802.11n(HT20): 6.5/13/19.5/26/39/52/58.5/65 Mbps/72.2Mbps 802.11n(HT40): 150Mbps
Number of Channels	11 Channels for 802.11b/g/n(HT20) 7 Channels for 802.11n(HT40)
Channel Separation:	5 MHz
Antenna Type	The wire antenna that uses a unique coupling to the intentional radiator
Antenna gain:	1 dBi
Function:	Module transmitter with 2.4 GHz WIFI
EUT Power Supply:	DC 3.3V

The module will be installed in indoor unit of air conditioner. The below model is a typical one:

Model No:	GWH09UC-D3DNA4A
EUT Power Supply:	AC 208/230V/ 60 Hz
Power cord:	1.8 m x 3 wires unscreened AC supply cable

EUT channels and frequencies list:

For 802.11b/g/n(HT20): test frequencies are the lowest channel 1: 2412 MHz, middle channel 6: 2437 MHz and the highest channel 11: 2462 MHz.

For 802.11n(HT40): test frequencies are the lowest channel 3: 2422 MHz, middle channel 6: 2437 MHz and the highest channel 9: 2452 MHz

Channel	Frequency (MHz)	Channel	Frequency (MHz)
1	2412	7	2442
2	2417	8	2447
3	2422	9	2452
4	2427	10	2457
5	2432	11	2462
6	2437	/	/

2.2 Related Submittal(s) Grants

This is an application for certification of:

DTS- Part 15 Digital Transmission Systems (WIFI transmitter portion)

The FCC ID and Canada IC of corresponding RF controller for this Module transmitter is 2ADAP-SAA1FB1F for FCC ID and 12478A-SAA1FB1F for Canada IC.

Remaining portions are subject to the following procedures:

1. Receiver portion of WIFI: exempt from technical requirement of this Part.
2. The Module transmitter function: exempt from FCC requirement.

2.3 Test Methodology

Both AC mains line-conducted and radiated emission measurements were performed according to the procedures in ANSI C63.10:2013. Radiated emission measurement was performed in semi-anechoic chamber and conducted emission measurement was performed in shield room. For radiated emission measurement, preliminary scans and final tests were performed in the semi-anechoic chamber to determine the worst case modes. All radiated tests were performed at an antenna to EUT distance of 3 meters, unless stated otherwise.

2.4 Test Facility

All of the tests are performed at:

Intertek Testing Services Shenzhen Ltd. Guangzhou Branch. located at Block E, No.7-2 Guang Dong Software Science Park, Caipin Road, Guangzhou Science City, GETDD Guangzhou, 510663, China.

This test facility and site measurement data have been fully placed on file with the FCC and IC, test firm registration number is 549654 for FCC and 2042U-1 for IC.

3.0 System Test Configuration

3.1 Justification

For emissions testing, the equipment under test (EUT) setup to transmit continuously to simplify the measurement methodology. During testing, AC power line was manipulated to produce worst case emissions. It was powered by DC 3.3V from air conditioner input AC 208/230V/60Hz supply.

The signal is maximized through rotation and placement in the three orthogonal axes. The antenna height and polarization are varied during the search for maximum signal level. The antenna height is varied from 1 to 4 meters. Radiated emissions are taken at three meters unless the signal level is too low for measurement at that distance. If necessary, a pre-amplifier is used and/or the test is conducted at a closer distance.

All readings are extrapolated back to the equivalent three meter reading using inverse scaling with distance. Analyzer resolution is 100 kHz or greater for frequencies below 1000 MHz. The resolution is 1 MHz or greater for frequencies above 1000 MHz. The spurious emissions more than 20 dB below the permissible value are not reported.

For an intentional radiator, the spectrum shall be investigated from the lowest radio frequency signal generated in the device, without going below 9 kHz, up to at least the frequency shown in the following table:

Frequency range of radiated emission measurements

Lowest frequency generated in the device	Upper frequency range of measurement
9 kHz to below 10 GHz	10th harmonic of highest fundamental frequency or to 40 GHz, whichever is lower.
At or above 10 GHz to below 30 GHz	5th harmonic of highest fundamental frequency or to 100 GHz, whichever is lower.
At or above 30 GHz	5th harmonic of highest fundamental frequency or to 200 GHz, whichever is lower, unless otherwise specified.

Number of fundamental frequencies to be tested in EUT transmit band

Frequency range in which device operates	Number of frequencies	Location in frequency range of operation
1 MHz or less	1	Middle
1 MHz to 10 MHz	2	1 near top and 1 near bottom
More than 10 MHz	3	1 near top, 1 near middle and 1 near bottom

3.2 EUT Exercising Software

The test was performed under “TTERMP” which was provided by manufacture.

3.4 Measurement Uncertainty

When determining of the test conclusion, the Measurement Uncertainty of test has been considered.

Uncertainty and Compliance – Unless the standard specifically states that measured values are to be extended by the measurement uncertainty in determining compliance, all compliance determinations are based on the actual measured value.

3.5 Equipment Modification

Any modifications installed previous to testing by Gree Electric Appliances, Inc. of Zhuhai. will be incorporated in each production model sold / leased in the United States.

No modifications were installed by Intertek Testing Services Shenzhen Ltd. Guangzhou Branch.

3.6 Support Equipment List and Description

This product was tested with corresponding accessories as below:

Supplied by Intertek:

Description	Manufacturer	Model No.	SN/Certificate NO
PC	HP	QV986AV	4CV35074HC
LCD Monitor	HP	EM886A	575201-001
Keyboard	HP	SK-2800	434820-AA1
Mouse	HP	OP-520NU	/

The support equipments were removed from test site after the frequency was fixed.

4.0 Measurement Results

4.1 Antenna Requirement:

Standard requirement

15.203 requirement:

For intentional device. According to 15.203 an intentional radiator shall be designed to Ensure that no antenna other than that furnished by the responsible party shall be used with the device.

15.247(c) (1)(i) requirement:

(i) Systems operating in the 2400-2483.5 MHz bands that are used exclusively for fixed. Point-to-point operations may employ transmitting antennas with directional gain greater than 6 dBi provided the maximum conducted output power of the intentional radiator is reduced by 1 dB for every 3 dB that the directional gain of the antenna exceeds 6 dBi.

RSS-GEN section 7.1.2

A transmitter can only be sold or operated with antennas with which it was approved.

When a measurement at the antenna connector is used to determine RF output power, the effective gain of the device’s antenna shall be stated, based on measurement or on data from the antenna manufacturer. For transmitters of RF output power of 10 milliwatts or less, only the portion of the antenna gain that is in excess of 6 dBi (6 dB above isotropic gain) shall be added to the measured RF output power to demonstrate compliance with the radiated power limits specified in the applicable standard. For transmitters of output power greater than 10 milliwatts, the total antenna gain shall be added to the measured RF output power to demonstrate compliance to the specified radiated power limits.

EUT Antenna

The antenna is an PCB antenna and no consideration of replacement. The best case gain of the antenna is 1 dBi.

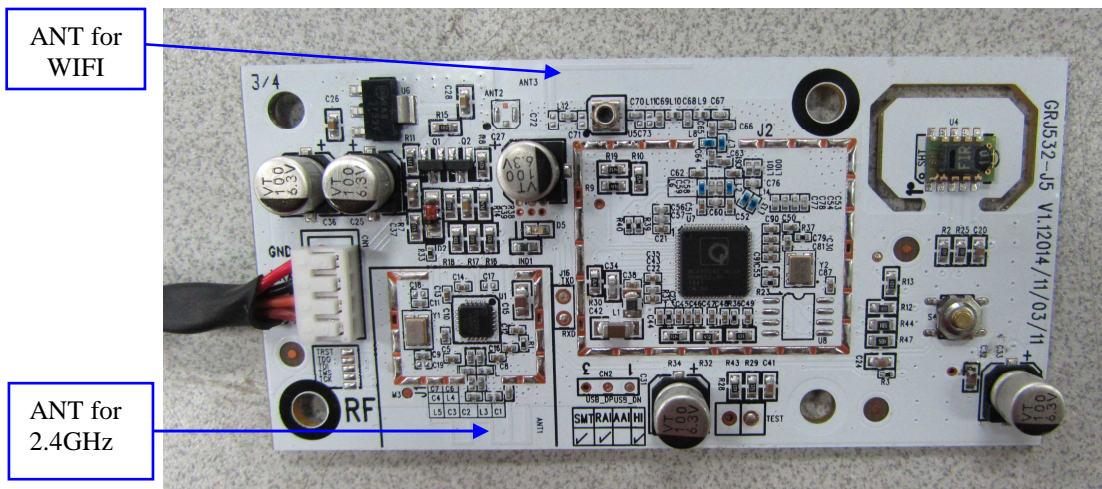

4.2 6 dB Bandwidth and Occupied Bandwidth:

Test Requirement: FCC Part 15 C section 15.247
 RSS-210 A8.2(a)
 (a)(2) Systems using digital modulation techniques may operate in the 902-928 MHz, 2400-2483.5MHz, and 5725-5850 MHz bands. The minimum 6 dB bandwidth shall be at least 500 kHz.

Test Method: ANSI C63.10: Clause 6.9.1 & RSS-Gen clause 4.6

Test Status: Pre-Scan has been conducted to determine the worst-case mode from all possible combinations between available modulations, data rates and antenna ports (if EUT with antenna diversity architecture). Following channel(s) was (were) selected for the final test as listed below.

Test Configuration:

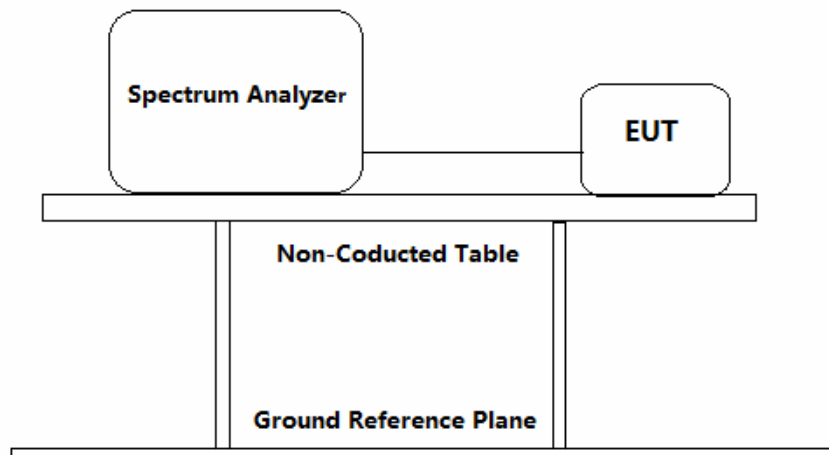

Test Procedure:

1. Remove the antenna from the EUT and then connect a low attention attenuation RF cable (cable loss =2 dB) from the antenna port to the spectrum.
2. Set the spectrum analyzer:
 Sweep = auto; Detector Function = Peak; ace = Max Hold
 RBW: 1%~5% OBW ; VBW: $\geq 3 \cdot RBW$
 Span=2*OBW~5*OBW
3. Mark the peak power frequency and -6dB (upper and lower) power frequency.
4. Repeat until all the test status is investigated.
5. Report the worst case.

6 dB bandwidth:

Channel No.	Frequency (MHz)	Mode	Data Rate	Measured 6dB bandwidth (MHz)	Limit	Result
1	2412	802.11b	11 Mbps	10.055	≥500KHz	Pass
6	2437		11 Mbps	9.825		Pass
11	2462		11 Mbps	9.795		Pass
1	2412	802.11g	54 Mbps	16.480		Pass
6	2437		54 Mbps	16.480		Pass
11	2462		54 Mbps	16.560		Pass
1	2412	802.11n (HT20)	72.2 Mbps	17.760		Pass
6	2437		72.2 Mbps	17.760		Pass
11	2462		72.2 Mbps	17.840		Pass
3	2422	802.11n (HT40)	150 Mbps	36.360		Pass
6	2437		150 Mbps	36.480		Pass
9	2452		150 Mbps	36.480		Pass

Test result: The unit does meet the FCC requirements.

99% bandwidth:

Channel No.	Frequency (MHz)	Mode	Data Rate	Measured 99% bandwidth (MHz)	Limit	Result
1	2412	802.11b	11 Mbps	13.710	/	Pass
6	2437		11 Mbps	13.700		Pass
11	2462		11 Mbps	13.720		Pass
1	2412	802.11g	54 Mbps	16.480		Pass
6	2437		54 Mbps	16.425		Pass
11	2462		54 Mbps	16.425		Pass
1	2412	802.11n (HT20)	72.2 Mbps	17.760		Pass
6	2437		72.2 Mbps	17.760		Pass
11	2462		72.2 Mbps	17.760		Pass
3	2422	802.11n (HT40)	150 Mbps	36.360		Pass
6	2437		150 Mbps	36.120		Pass
9	2452		150 Mbps	36.360		Pass

Test result: The unit does meet the RSS requirements.

6 dB bandwidth:

Result plot as follows:

802.11b mode with 11Mbps data rate
 Channel 1: 2.412GHz:

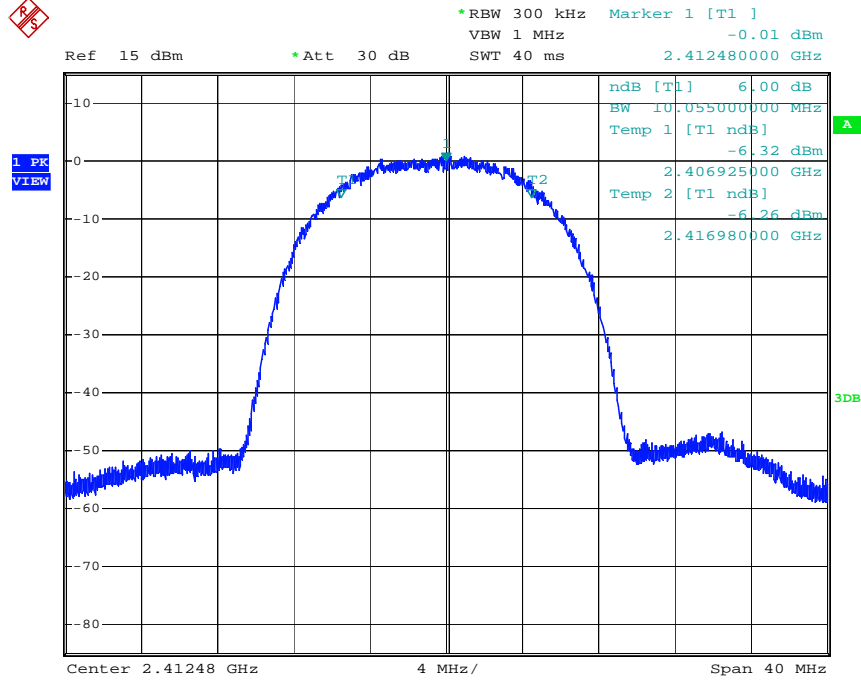

Channel 6: 2.437GHz:

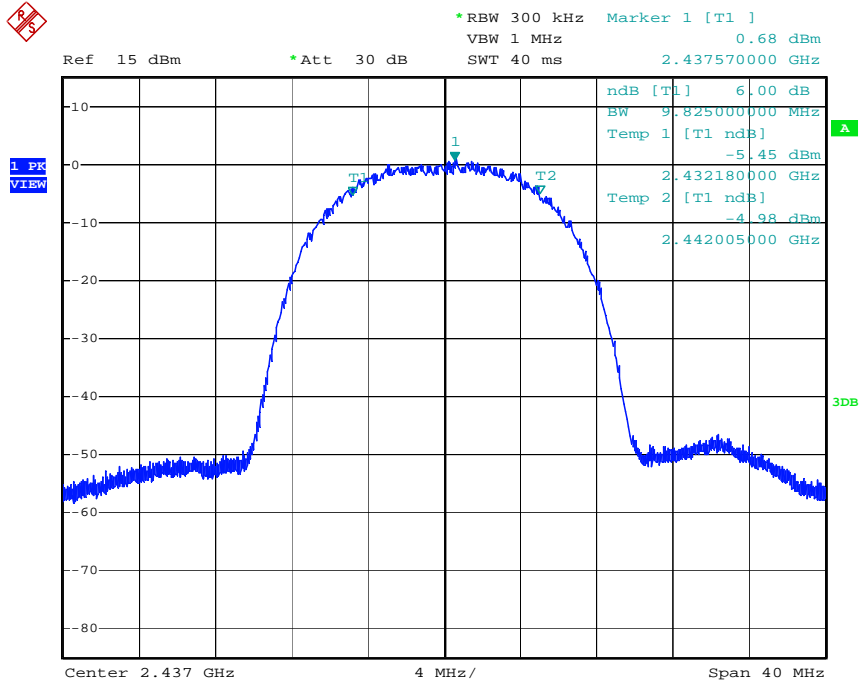

Channel 11: 2.462GHz

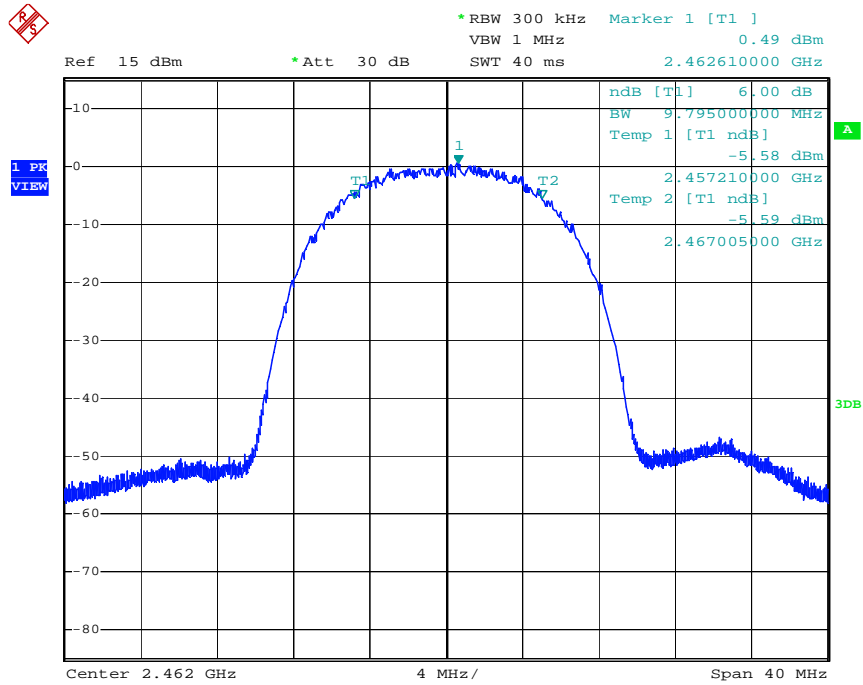

802.11g mode with 54Mbps data rate
 Channel 1: 2.412GHz:

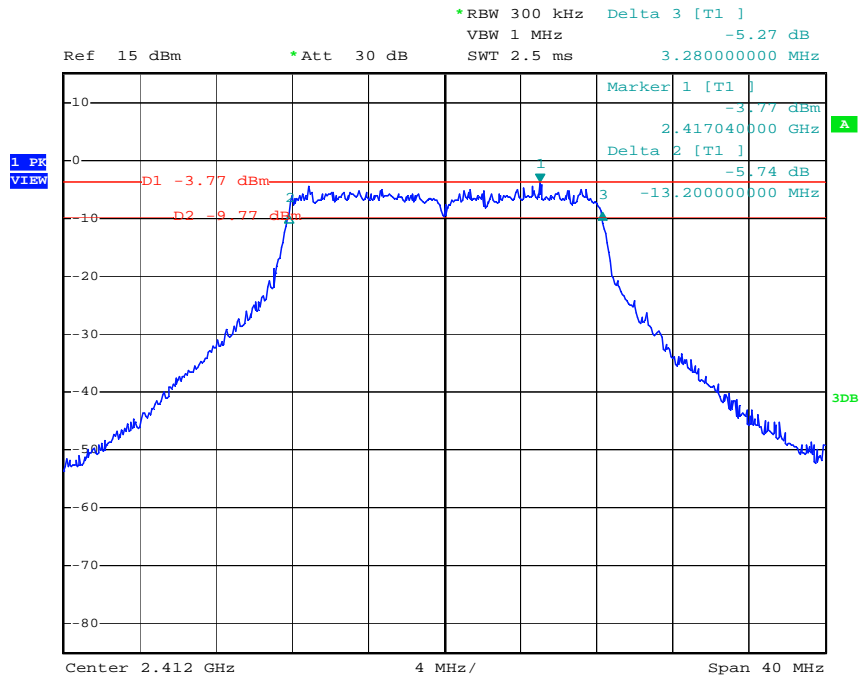

Channel 6: 2.437GHz:

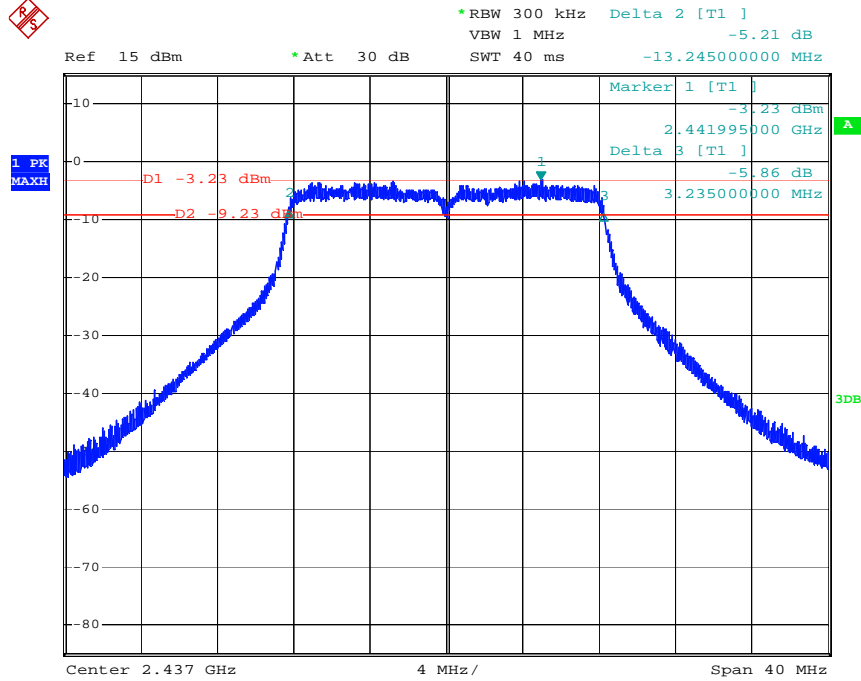

Channel 11: 2.462GHz:

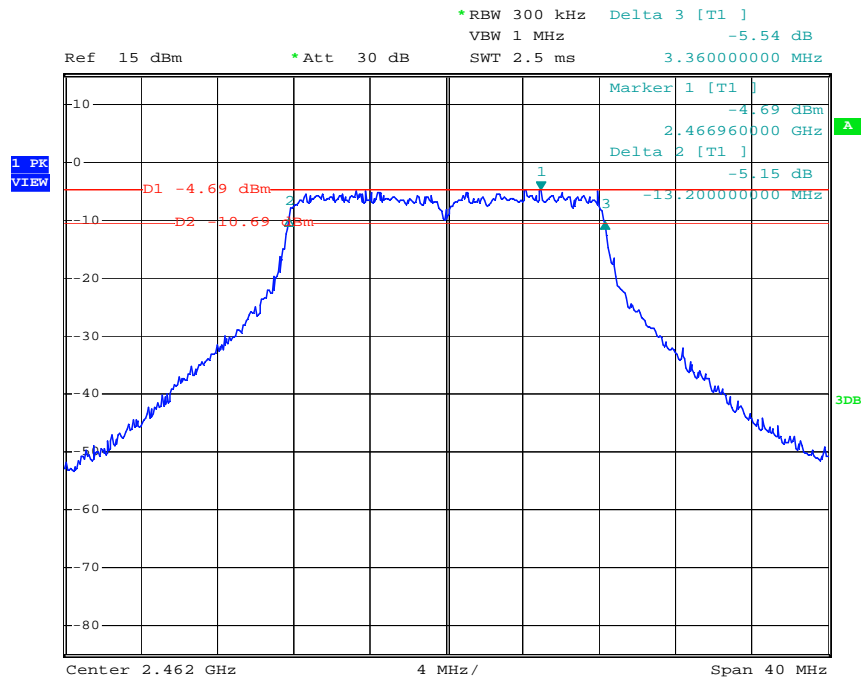

802.11n(HT20) mode with 72.2Mbps data rate
 Channel 1: 2.412GHz:

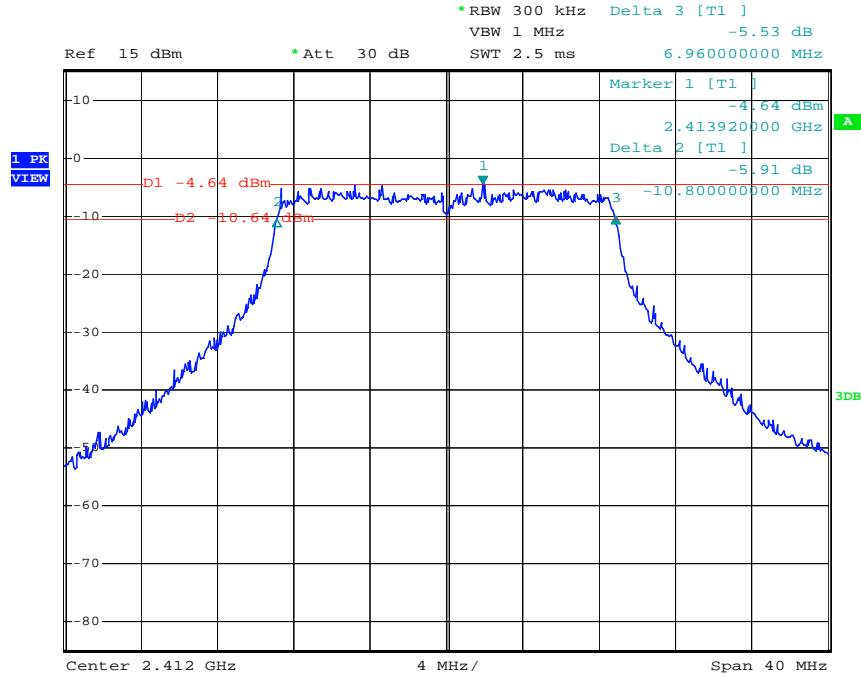

Channel 6: 2.437GHz:

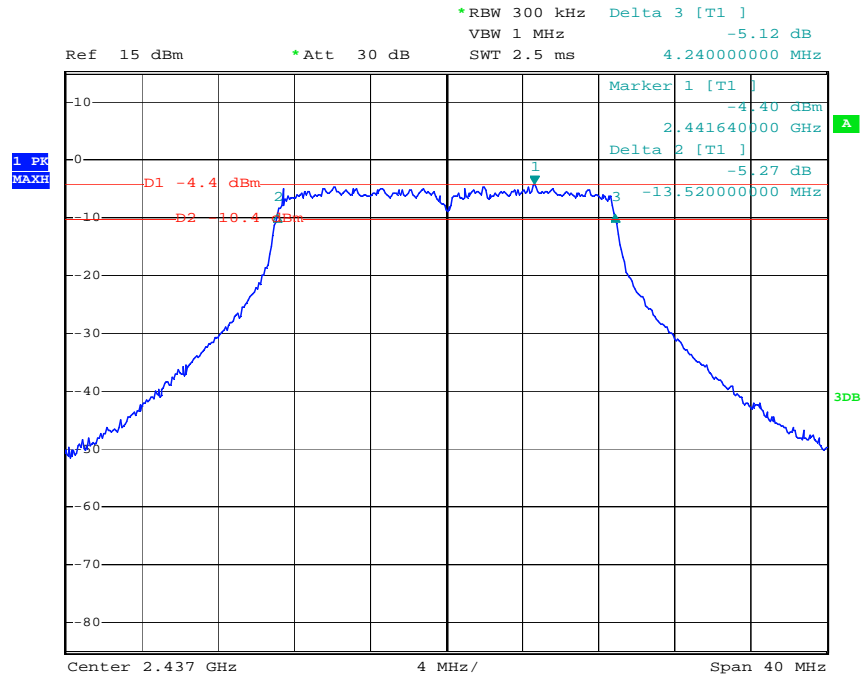

Channel 11: 2.462GHz:

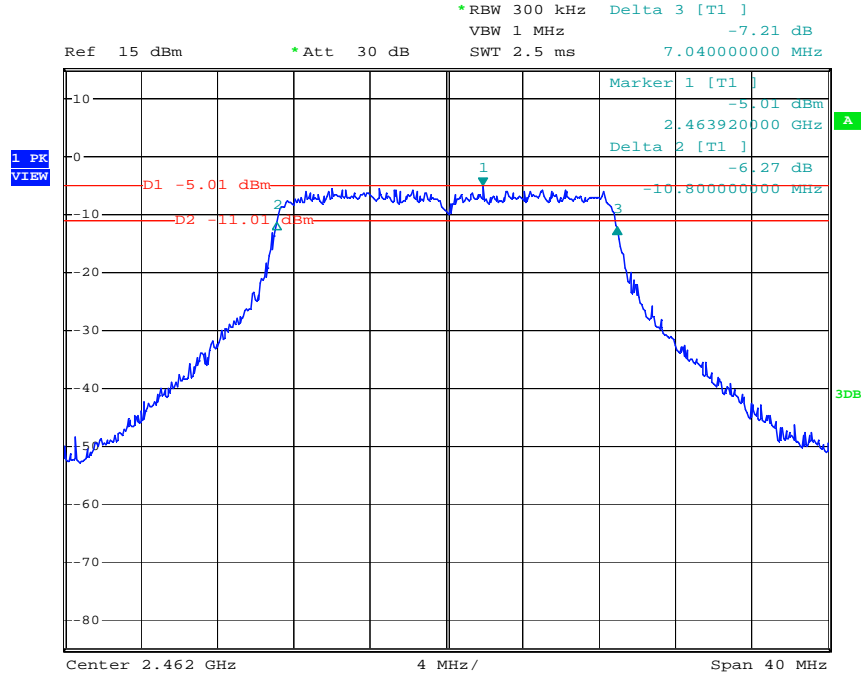

802.11n(HT40) mode with 150Mbps data rate

Channel 3: 2.422GHz:

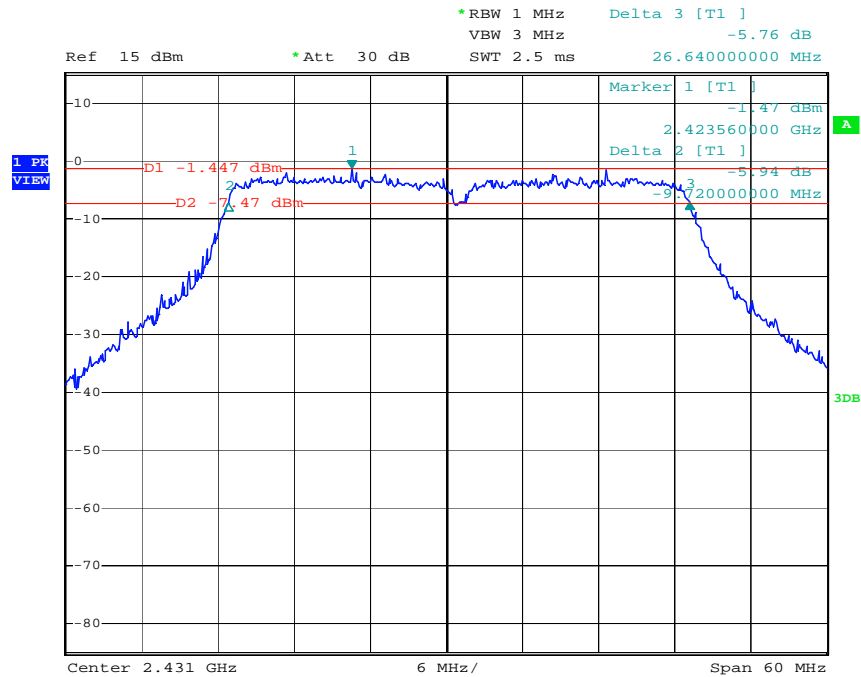

Channel 6: 2.437GHz:

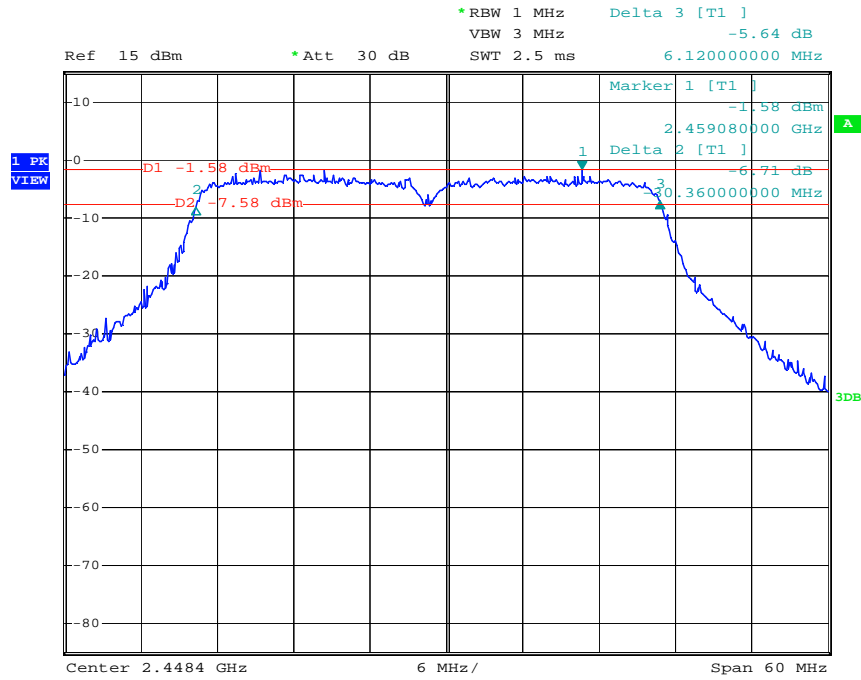

Channel 9: 2.452GHz:

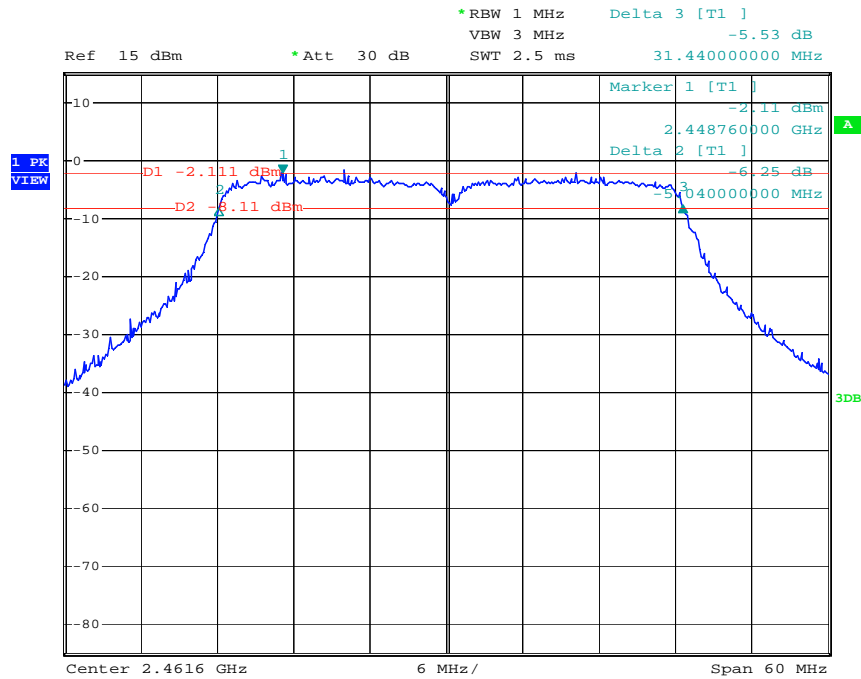

99% bandwidth:

Result plot as follows:

802.11b mode with 11Mbps data rate

Channel 1: 2.412GHz:

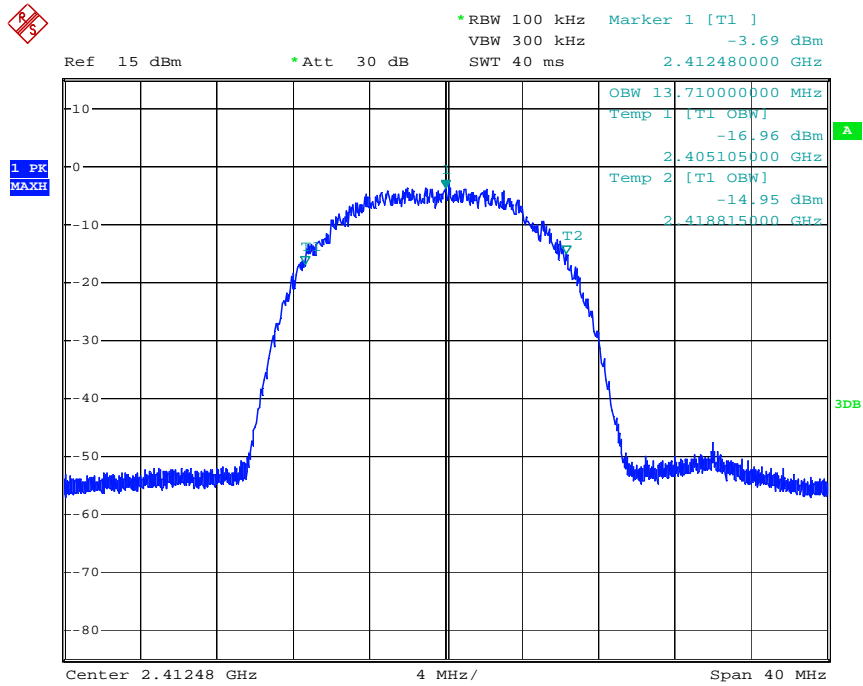

Channel 6: 2.437GHz:

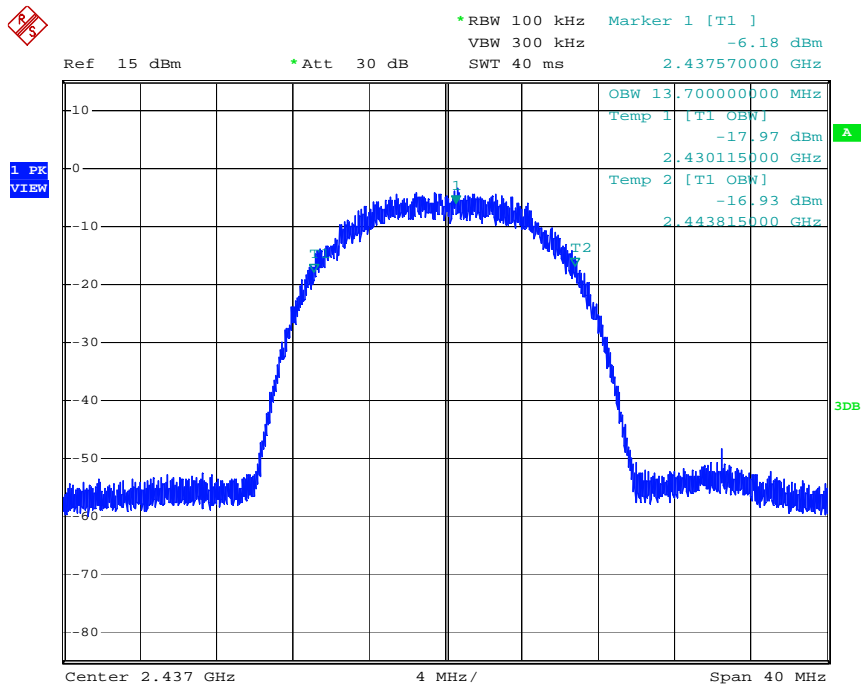

Channel 11: 2.462GHz:

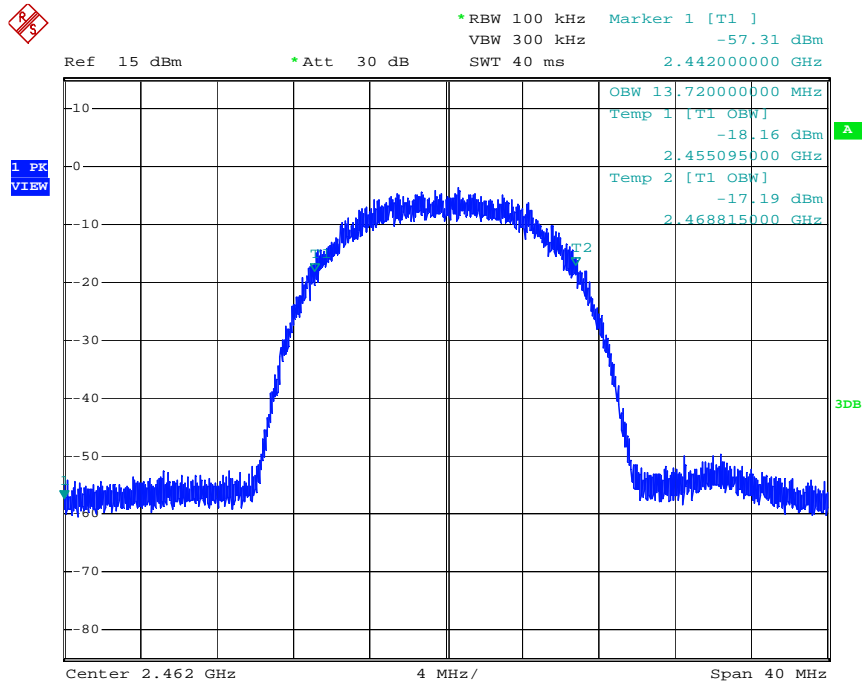

802.11g mode with 54Mbps data rate
 Channel 1: 2.412GHz:

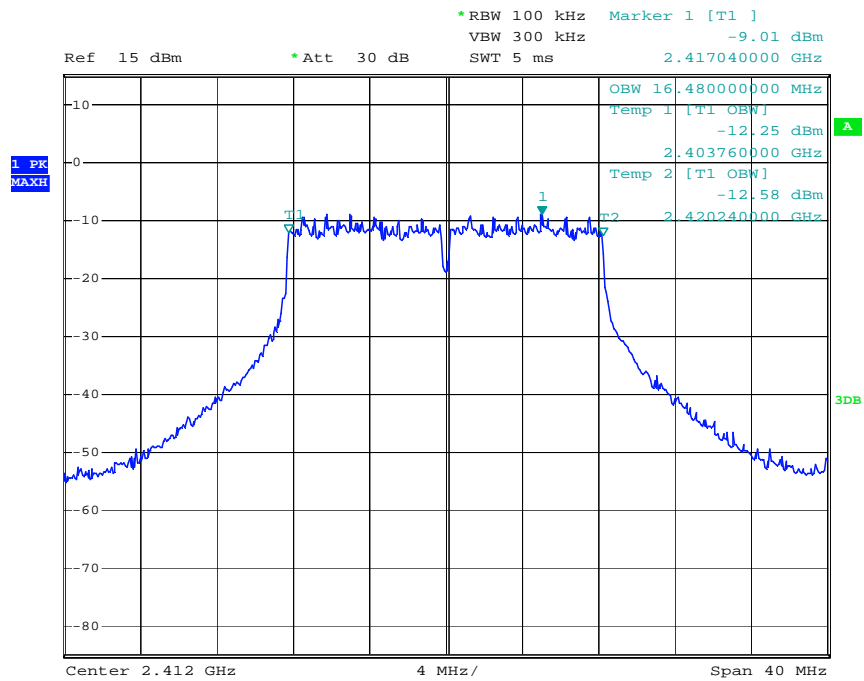

Channel 6: 2.437GHz:

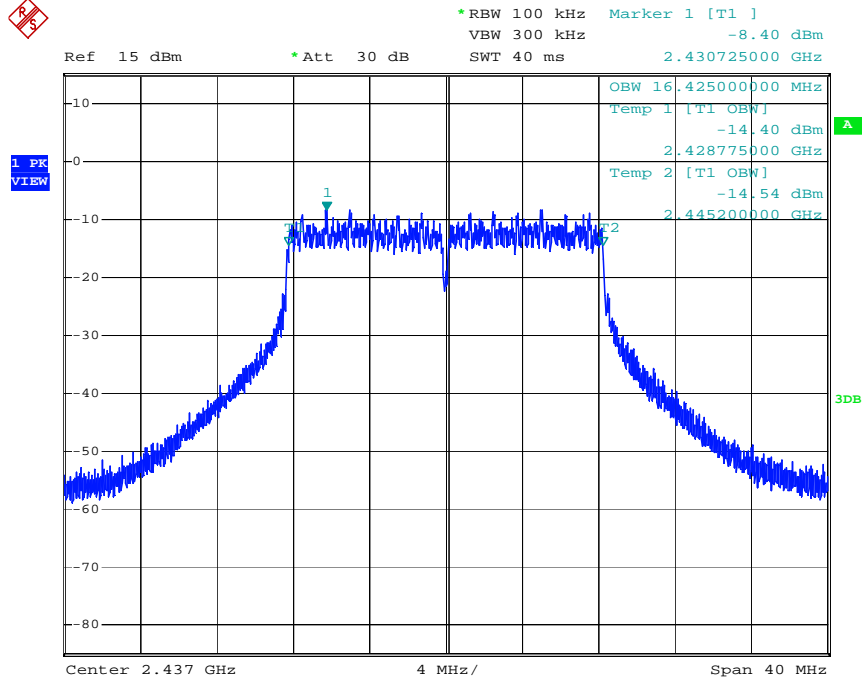

Channel 11: 2.462GHz:

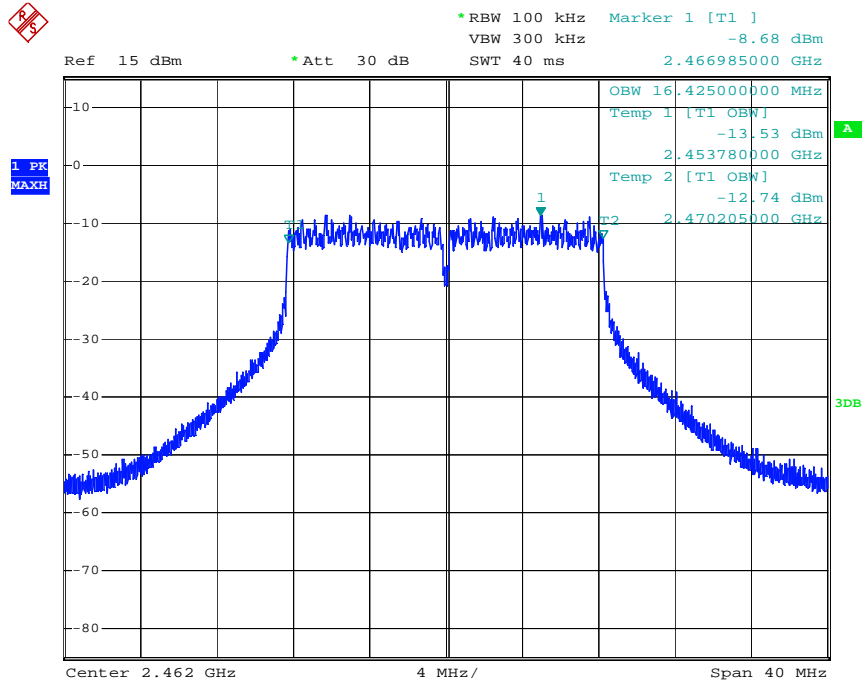

802.11n(HT20) mode with 72.2Mbps data rate
 Channel 1: 2.412GHz:

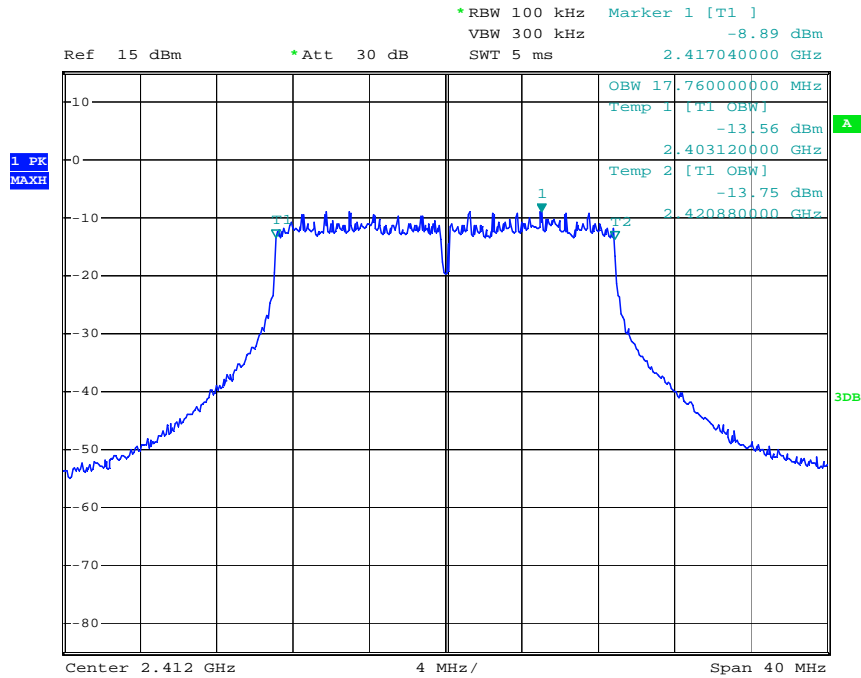

Channel 6: 2.437GHz:

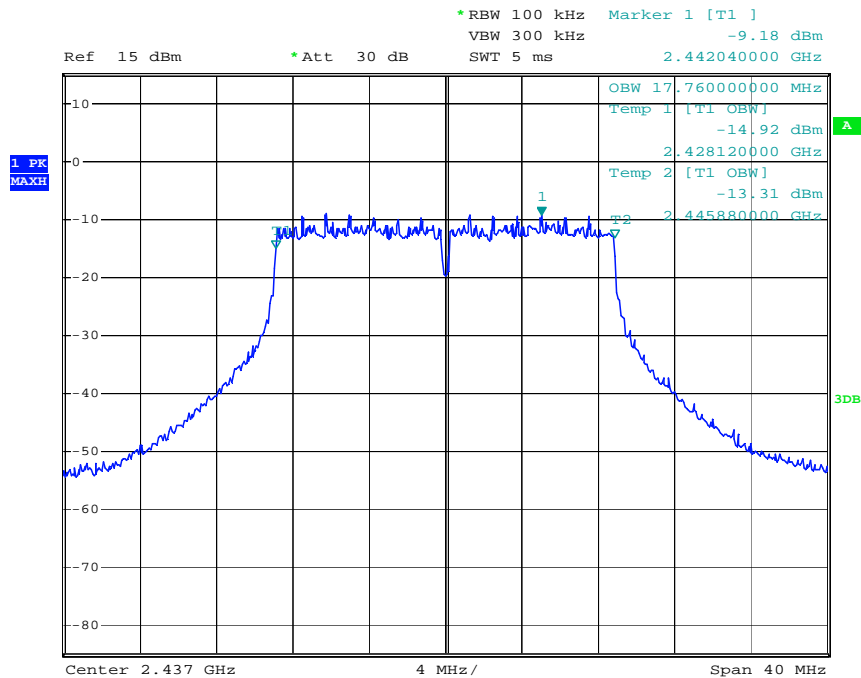

Channel 11: 2.462GHz:

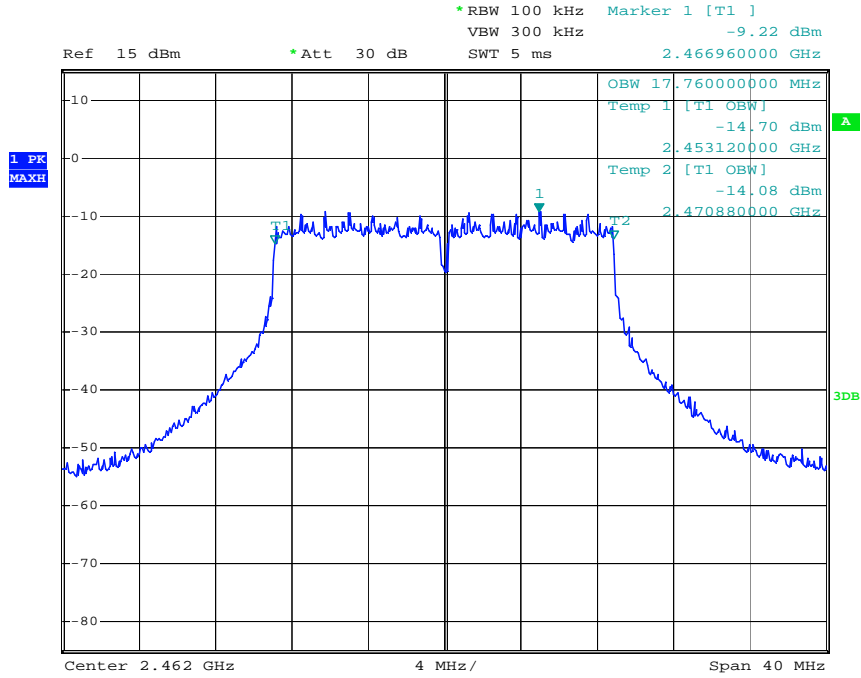

802.11n(HT40) mode with 150Mbps data rate
 Channel 3: 2.422GHz:

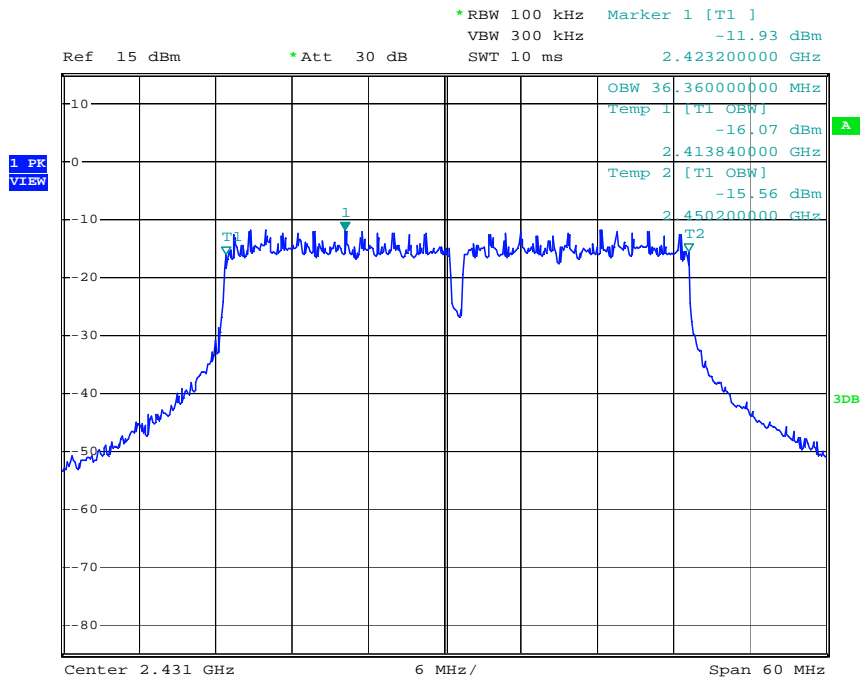

Channel 6: 2.437GHz:

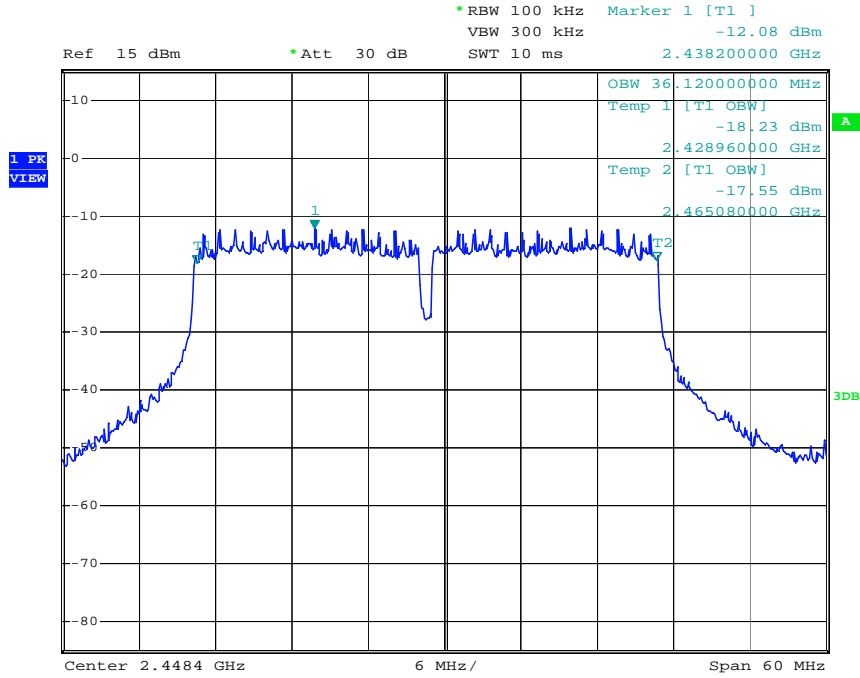

Channel 9: 2.452GHz:

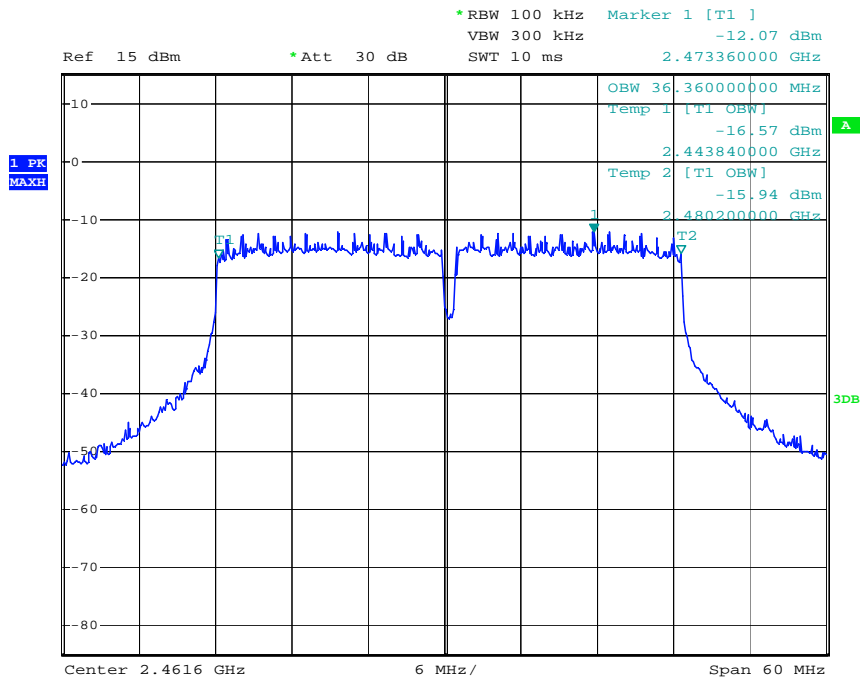

4.3 Maximum Peak Conducted Output Power and e.i.r.p

- Test Requirement:** FCC Part 15 C section 15.247
RSS-210 A8.4(4)
For systems employing digital modulation techniques operating in the bands 902-928 MHz, 2400-2483.5 MHz and 5725-5850 MHz, the maximum peak conducted output power shall not exceed 1 W. The e.i.r.p. shall not exceed 4 W.
Except as shown in paragraph (c) of this section, if transmitting antennas of directional gain greater than 6 dBi are used, the conducted output power from the intentional radiator shall be reduced below the stated values in paragraphs (b) (1), (b) (2), and (b) (3) of this section, as appropriate, by the amount in dB that the directional gain of the antenna exceeds 6 dBi.
- Test Method:** ANSI C63.10: Clause 6.10.2.1& RSS-Gen clause 4.8 (Channel integration method)
- Test Status:** Pre-Scan has been conducted to determine the worst-case mode from all possible combinations between available modulations, data rates and antenna ports (if EUT with antenna diversity architecture). Following channel(s) was (were) selected for the final test as listed below.
- Test Configuration:**

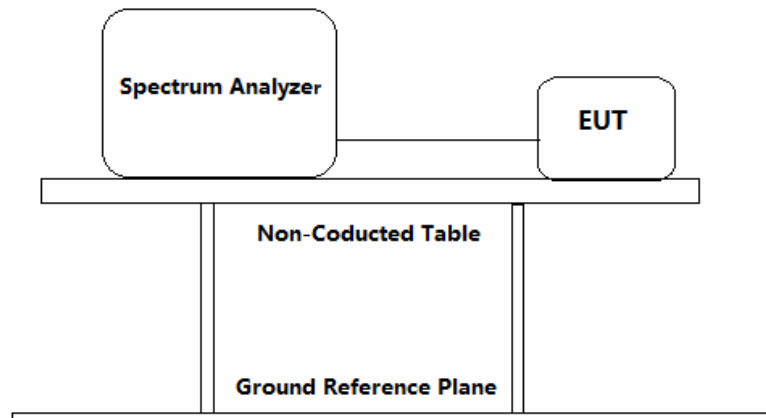

Test Procedure:

- a) Set the RBW \geq 6 dB bandwidth of the emission, or use a peak power meter. A peak power meter is required if the 6 dB bandwidth is greater than the capability of the spectrum analyzer (typically 3 MHz RBW).
- b) Channel integration method. For peak output power measurements when the analyzer RBW is not large enough, the analyzer band power function can be used. For U-NII output power measurements where power averaging is allowed, see 6.10.3. For the channel integration method, maximum peak power shall be measured over any interval of continuous transmission.
 - 1) Set the RBW and VBW to the maximum available
 - 2) Set the band limits as appropriate for the power measurement; e.g., 6 dB, 20 dB, or 26 dB bandwidth. Expand the band limits by about $0.5 \times$ RBW on each end
 - 3) Turn averaging off
 - 4) Set sweep to automatic
 - 5) Set the span just large enough to capture the emission
 - 6) Use a peak detector on max hold
 - 7) The analyzer should be in linear (rather than log) display mode
 - 8) Let the emission stabilize before making a final reading
- c) Bandwidth correction method. Using largest available analyzer RBW, the BW correction factor is $10 \log [(6 \text{ dB BW of emission}) / (\text{analyzer RBW})]$.
- d) Record the measured power.



Test result:

Channel No.	Frequency (MHz)	Mode	Data Rate	Measured Channel Power (dBm)	Limit	Result
1	2412	802.11b	11 Mbps	14.52	1W (30dBm)	Pass
6	2437		11 Mbps	14.28		Pass
11	2462		11 Mbps	14.14		Pass
1	2412	802.11g	54 Mbps	14.52		Pass
6	2437		54 Mbps	14.15		Pass
11	2462		54 Mbps	13.96		Pass
1	2412	802.11n (HT20)	72.2 Mbps	13.88		Pass
6	2437		72.2 Mbps	14.35		Pass
11	2462		72.2 Mbps	13.75		Pass
3	2422	802.11n (HT40)	150 Mbps	14.22		Pass
6	2437		150 Mbps	13.92		Pass
9	2452		150 Mbps	14.06		Pass

Remark: Level = Read Level + Cable Loss(3dB).
 The unit does meet the FCC requirements and the RSS requirements.

Result plot as follows:

802.11b mode with 11Mbps data rate

Channel 1: 2.412GHz:

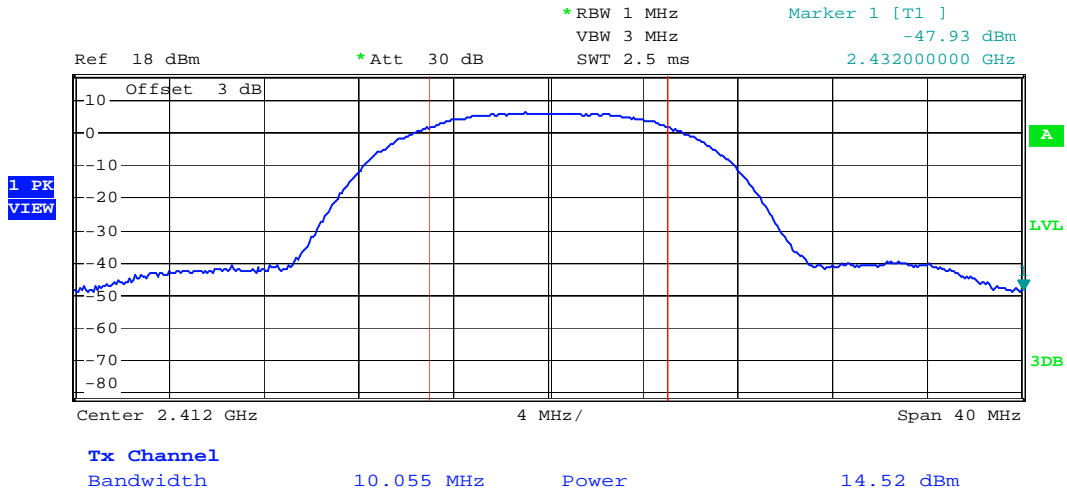

Channel 6: 2.437GHz:

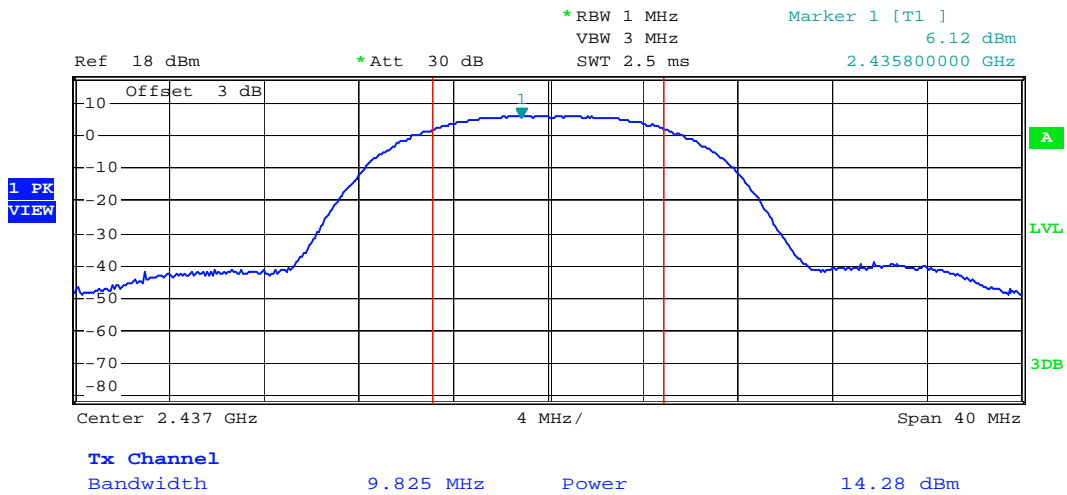

Channel 11: 2.462GHz:

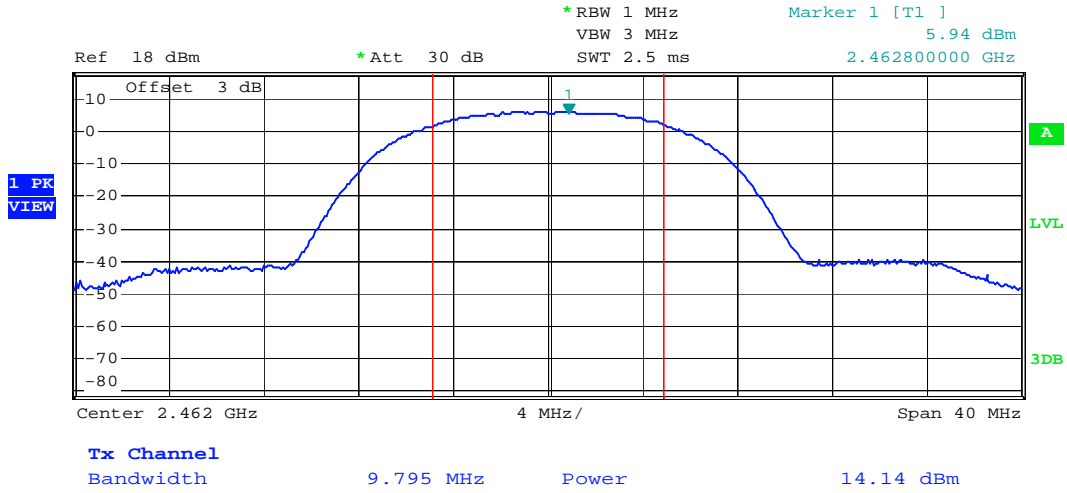

802.11g mode with 54Mbps data rate

Channel 1: 2.412GHz:

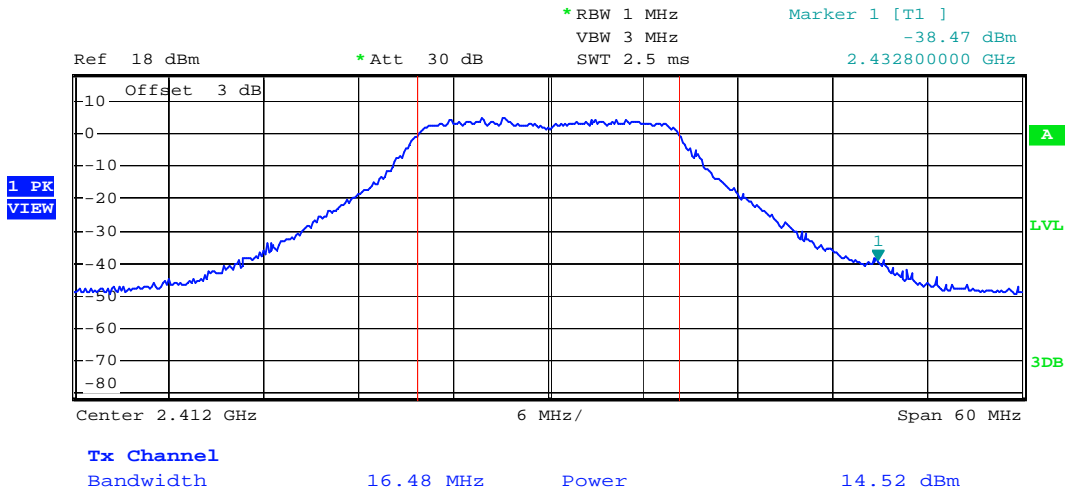

Channel 6: 2.437GHz:

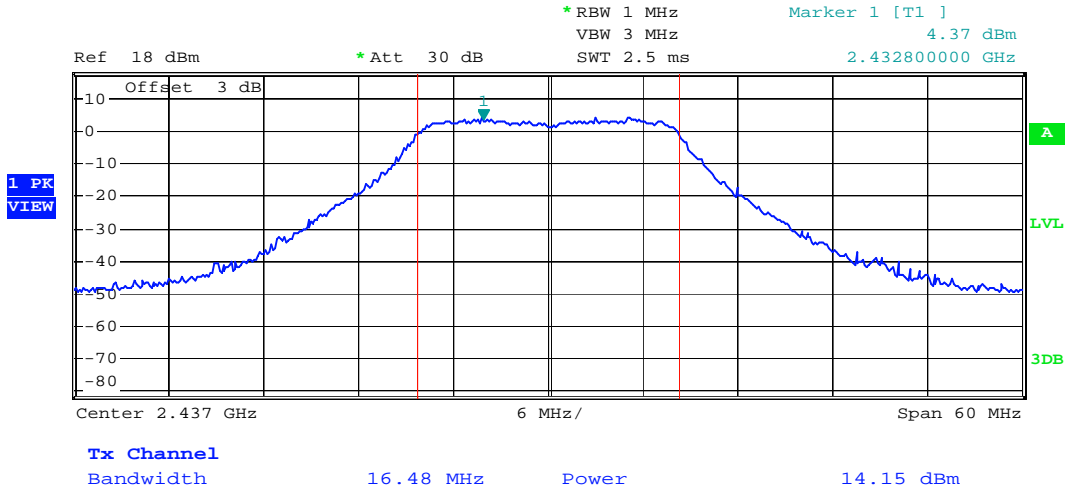

Channel 11: 2.462GHz:

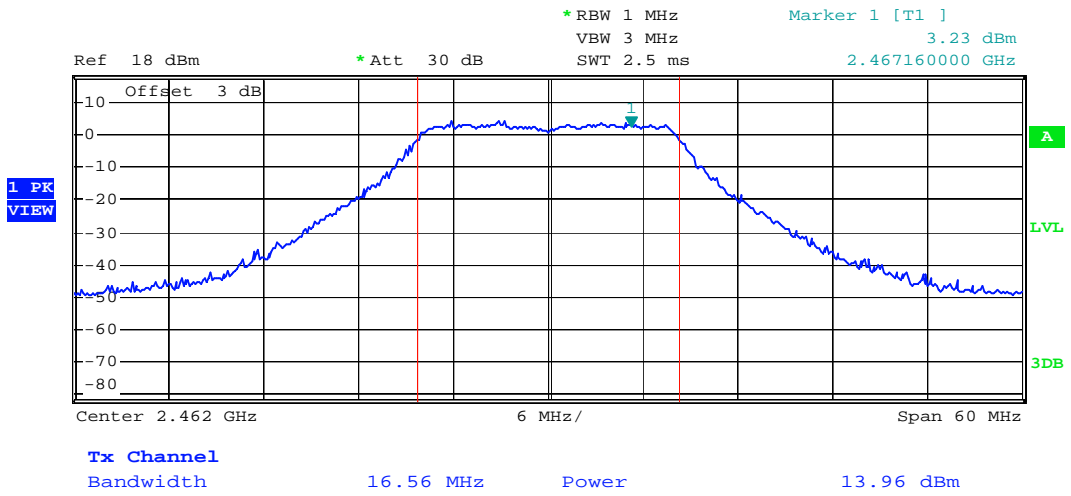

802.11n(HT20) mode with 72.2Mbps data rate
 Channel 1: 2.412GHz:

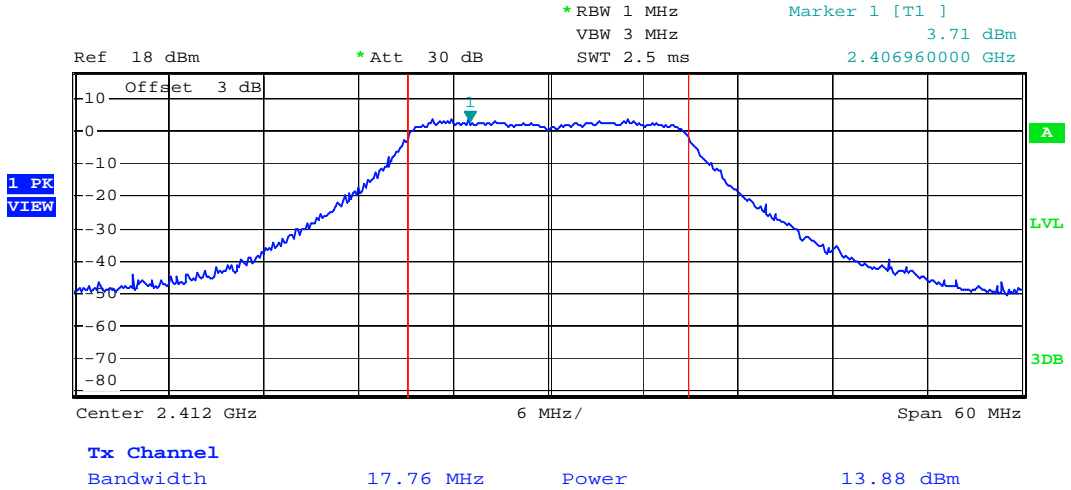

Channel 6: 2.437GHz:

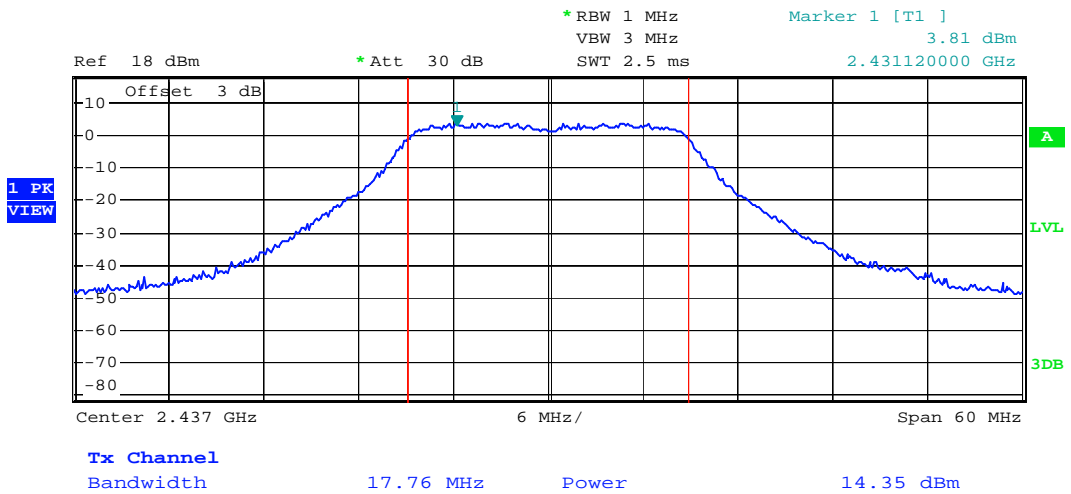

Channel 11: 2.462GHz:

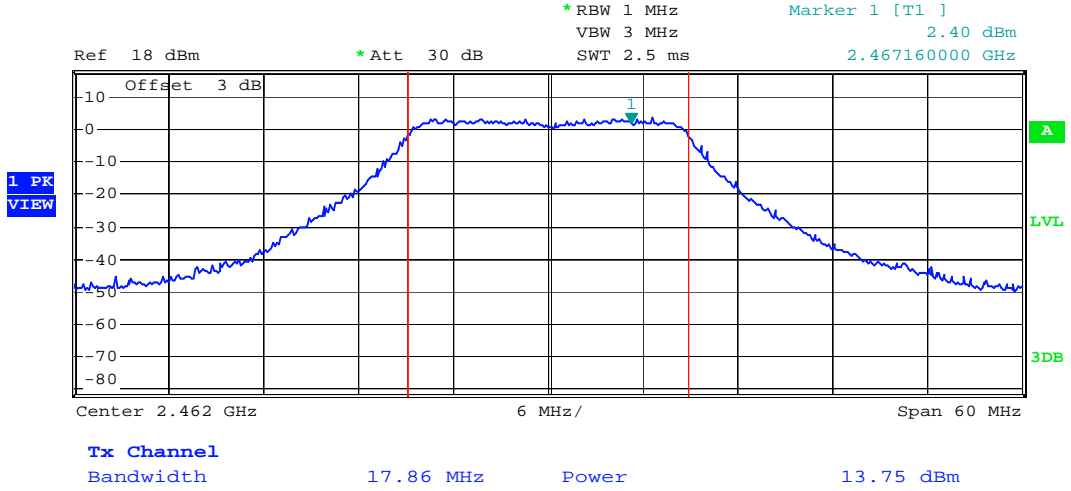

802.11n(HT40) mode with 150Mbps data rate
 Channel 3: 2.422GHz:

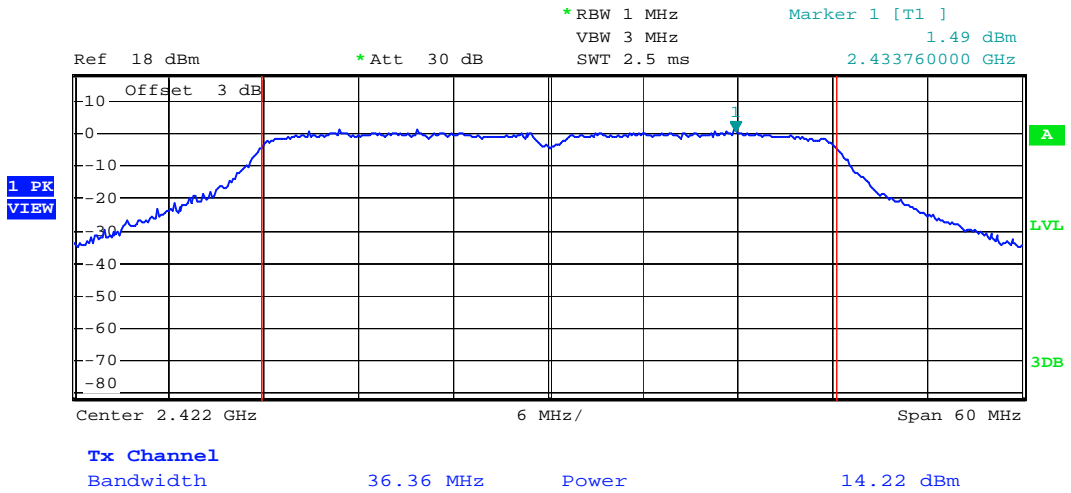

Channel 6: 2.437GHz:

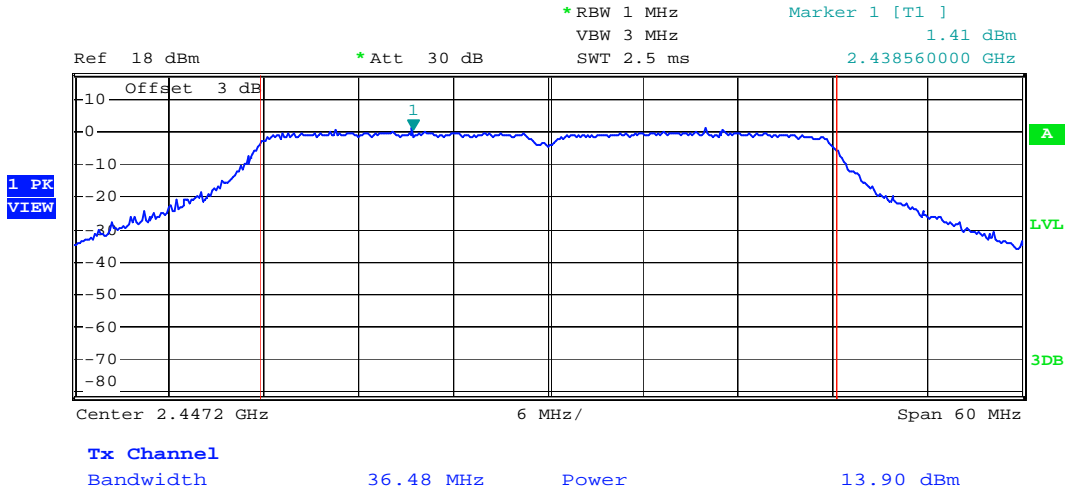

Channel 9: 2.452GHz:

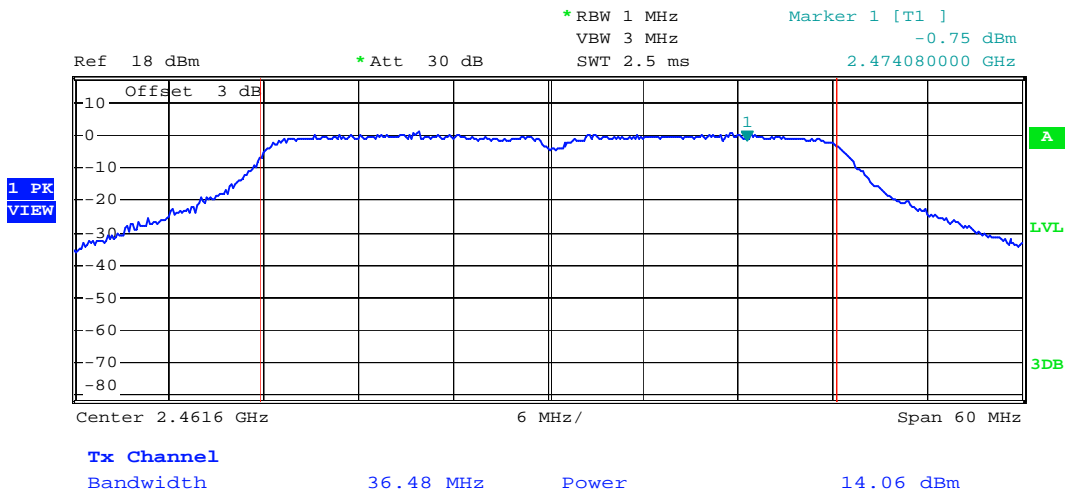

4.4 Peak Power Spectral Density

Test Requirement: FCC Part 15 C section 15.247
RSS-210 A8.4(4)
For digitally modulated systems, the power spectral density conducted from the intentional radiator to the antenna shall not be greater than 8 dBm in any 3 kHz band during any time interval of continuous transmission. The power spectral density shall be determined using the same method as is used to determine the conducted output power

Test Method: ANSI C63.10: Clause 6.11.2.3 & RSS-Gen clause 4.8

Test Status: Pre-Scan has been conducted to determine the worst-case mode from all possible combinations between available modulations, data rates and antenna ports (if EUT with antenna diversity architecture). Following channel(s) was (were) selected for the final test as listed below.

Test Configuration:

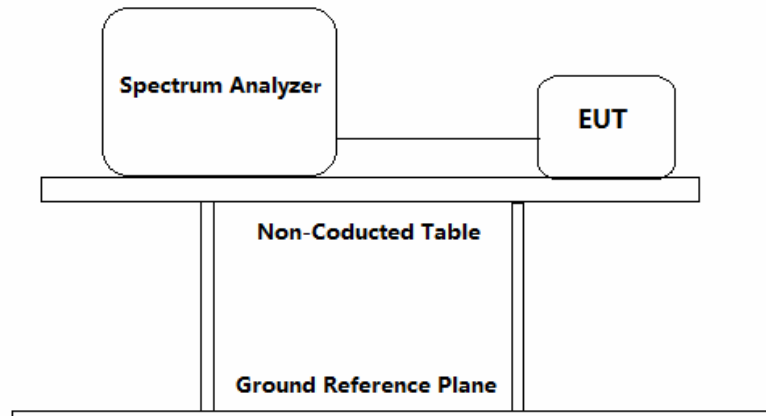

Test Procedure:

1. Remove the antenna from the EUT and then connect a low attention attenuation RF cable (cable loss =3dB) from the antenna port to the spectrum analyzer or power meter.
2. Set the spectrum analyzer:
 - a) Set CENTER FREQUENCY = Frequency from Power Spectral Density Test Matrix
 - b) Set SPAN = 20 MHz (For devices with a nominal 40 MHz BW, 50 MHz span will be needed)
 - c) Set REFERENCE LEVEL = 20 dBm
 - d) Set ATTENUATION = 0 dB
 - e) Set SWEEP TIME = Coupled
 - f) Set RBW = 3 kHz
 - g) Set VBW = 10 kHz
 - h) Set DETECTOR = Peak
 - i) Set MKR = Center Frequency
 - j) Set TRACE = CLEAR WRITE

Place the radio in continuous transmit mode. Set the TRACE to MAX HOLD, and after the trace stabilizes, the TRACE to VIEW. Set the marker on the peak of the signal and then adjust the center frequency of the spectrum analyzer to the marker frequency.

After viewing the EUT waveform on the spectrum analyzer, perform the following spectrum analyser functions to capture the trace:

Set SPAN = 300 kHz

Set SWEEP TIME = 100 s

Set TRACE = MAX HOLD

Set MKR = PEAK SEARCH

3. Measure the Power Spectral Density of the test frequency with special test status.
4. Repeat until all the test status is investigated.
5. Report the worst case.



Report No.: 141121032GZU-001
 Issued: 2015-01-08

Channel No.	Frequency (MHz)	Mode	Data Rate	Measured Peak Power Spectral Density (dBm/3KHz)	Limit	Result
1	2412	802.11b	11 Mbps	-15.47	8dBm/ 3 KHz	Pass
6	2437		11 Mbps	-15.97		Pass
11	2462		11 Mbps	-15.83		Pass
1	2412	802.11g	54 Mbps	-19.82		Pass
6	2437		54 Mbps	-19.96		Pass
11	2462		54 Mbps	-20.42		Pass
1	2412	802.11n (HT20)	72.2 Mbps	-18.46		Pass
6	2437		72.2 Mbps	-19.79		Pass
11	2462		72.2 Mbps	-21.35		Pass
3	2422	802.11n (HT40)	150 Mbps	-23.33		Pass
6	2437		150 Mbps	-22.67		Pass
9	2452		150 Mbps	-22.71		Pass

Test result: Level = Read Level + Cable Loss(3dB).
 The unit does meet the FCC requirements and the RSS requirements.

Result plot as follows:

802.11b mode with 11Mbps data rate

Channel 1: 2.412GHz:

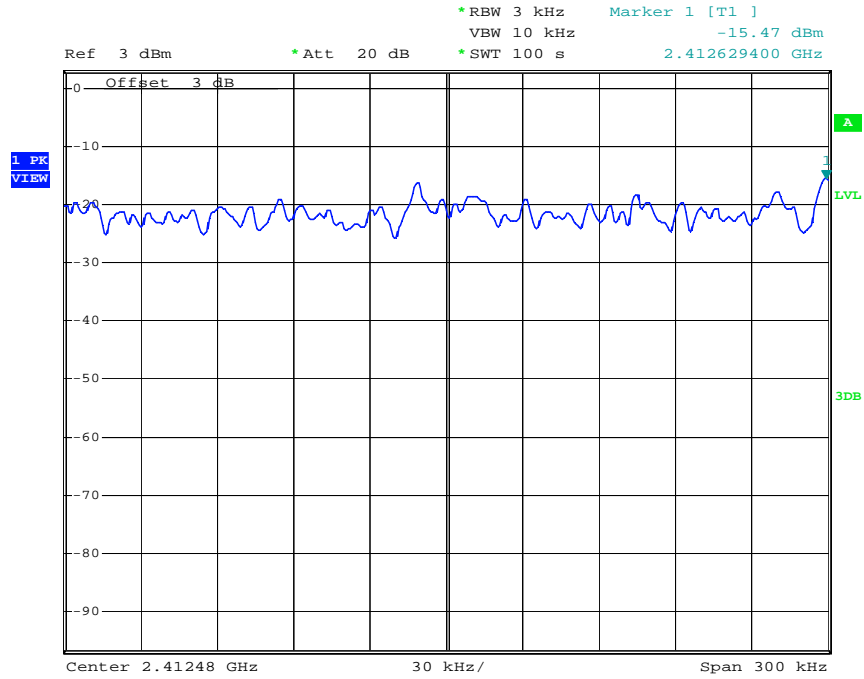

Channel 6: 2.437GHz:

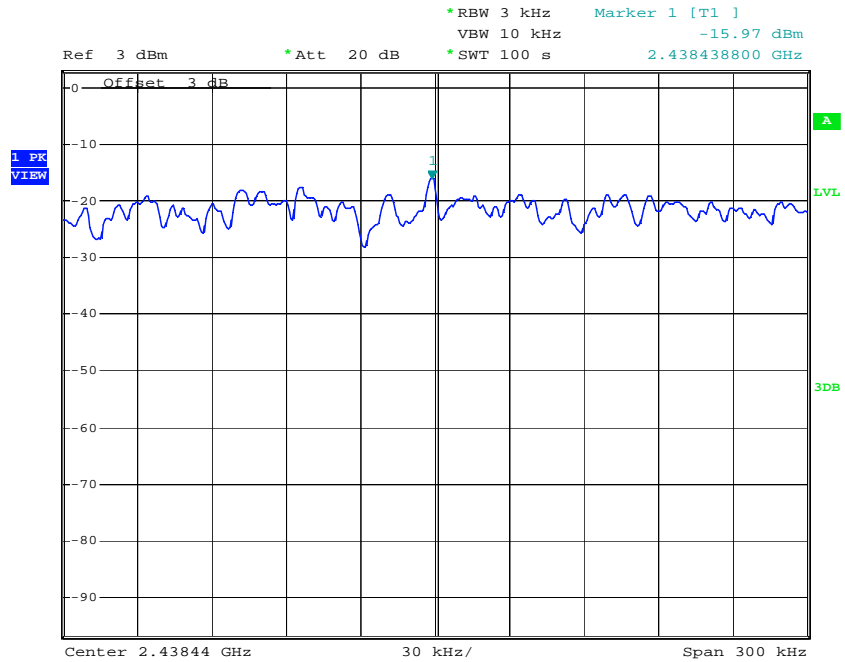

Channel 11: 2.462GHz:

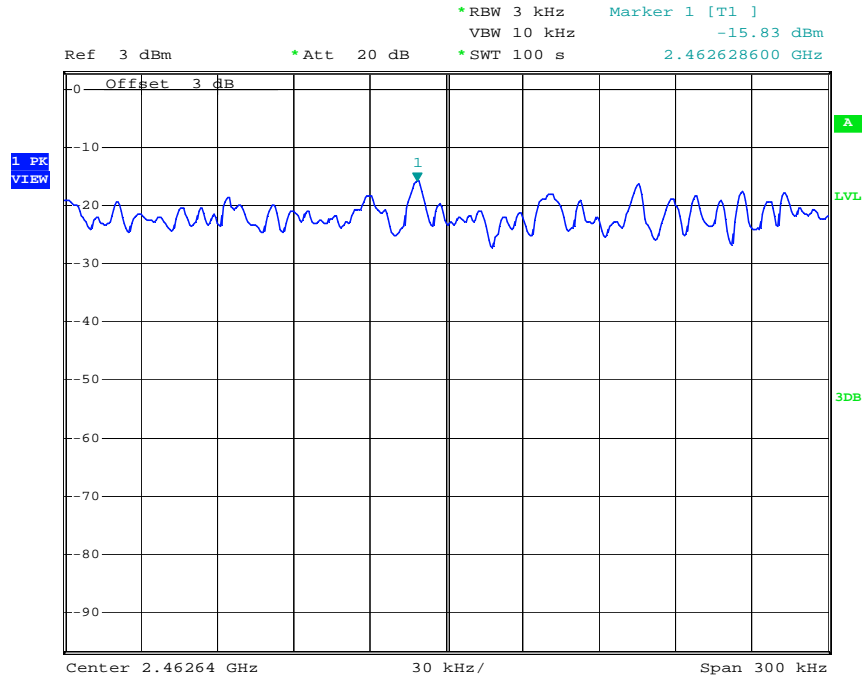

802.11g mode with 54Mbps data rate
Channel 1: 2.412GHz:

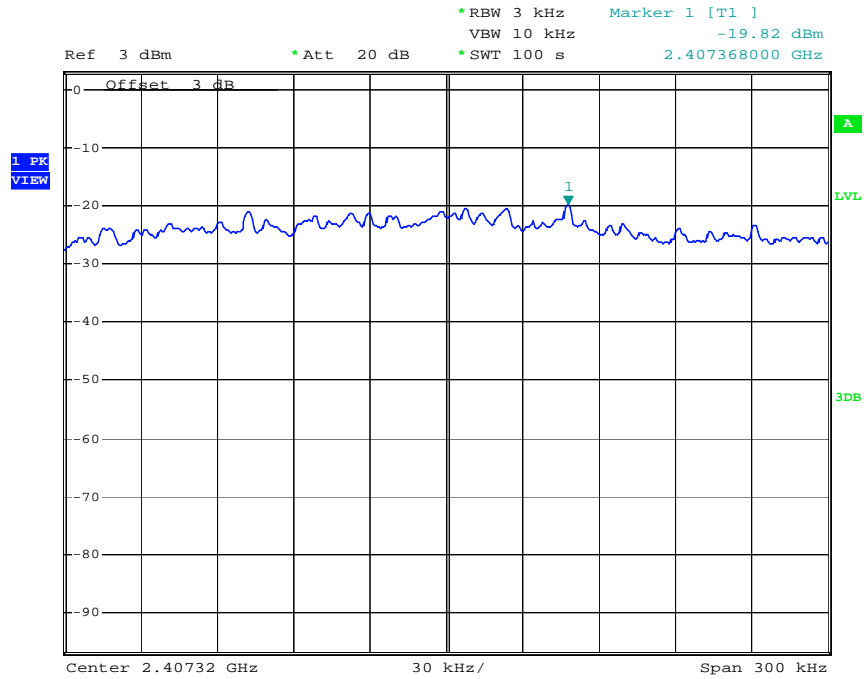

Channel 6: 2.437GHz:

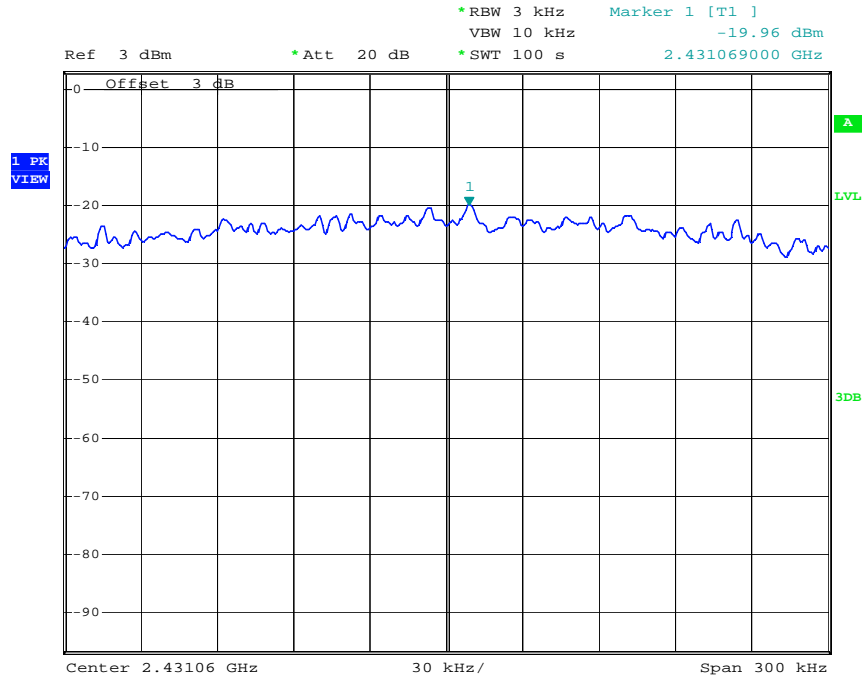

Channel 11: 2.462GHz:

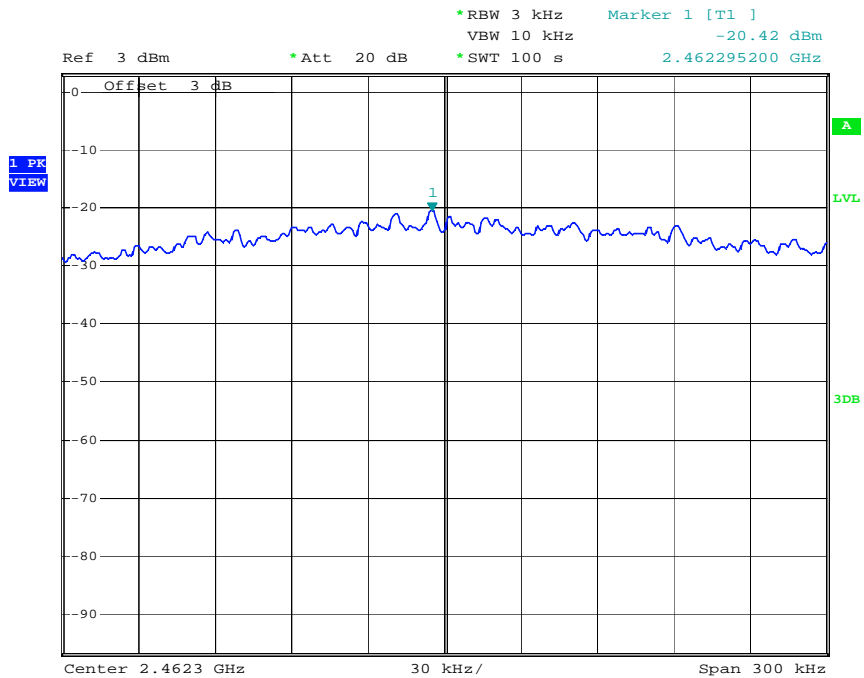

802.11n(HT20) mode with 72.2Mbps data rate
Channel 1: 2.412GHz:

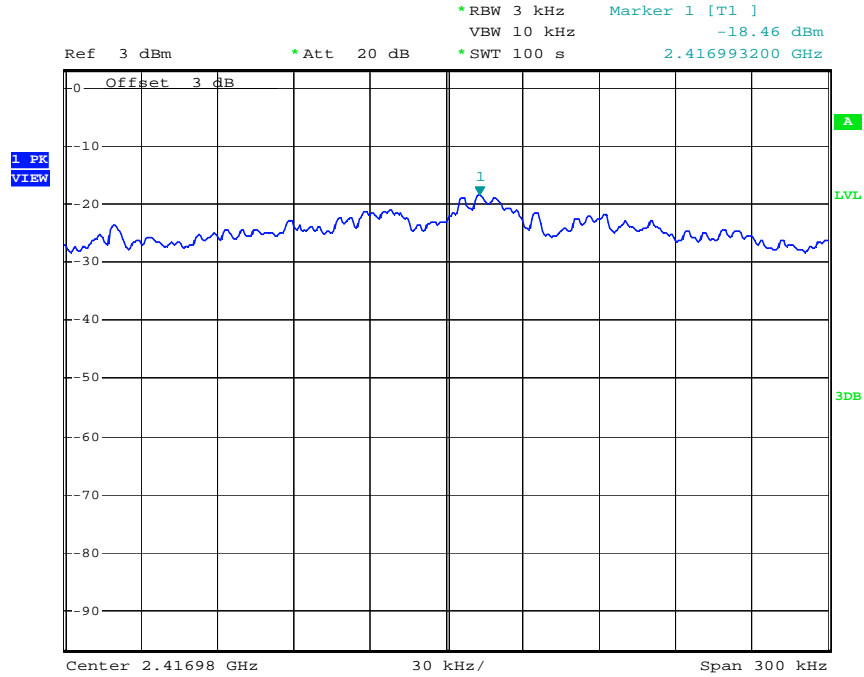

Channel 6: 2.437GHz:

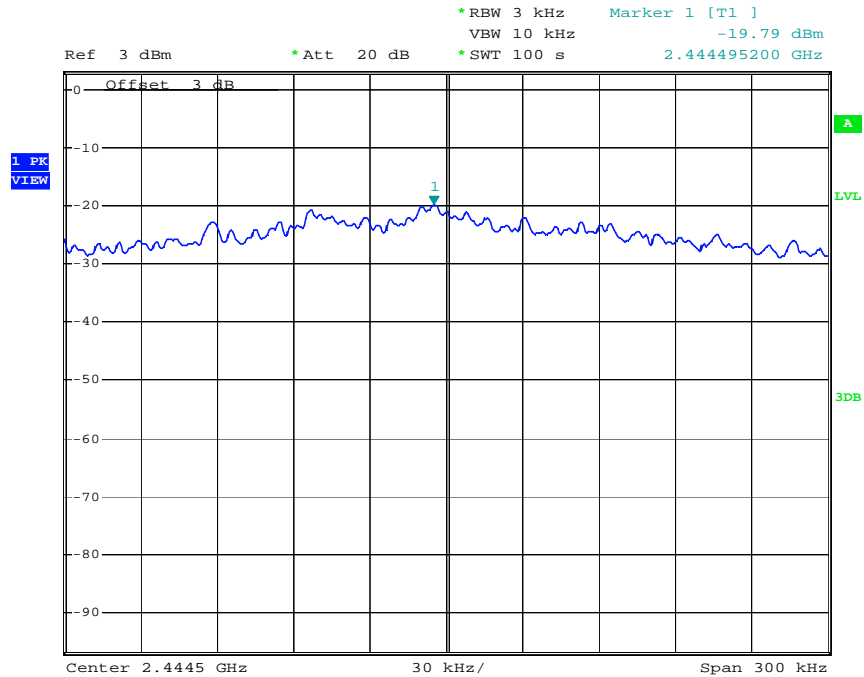

Channel 11: 2.462GHz:

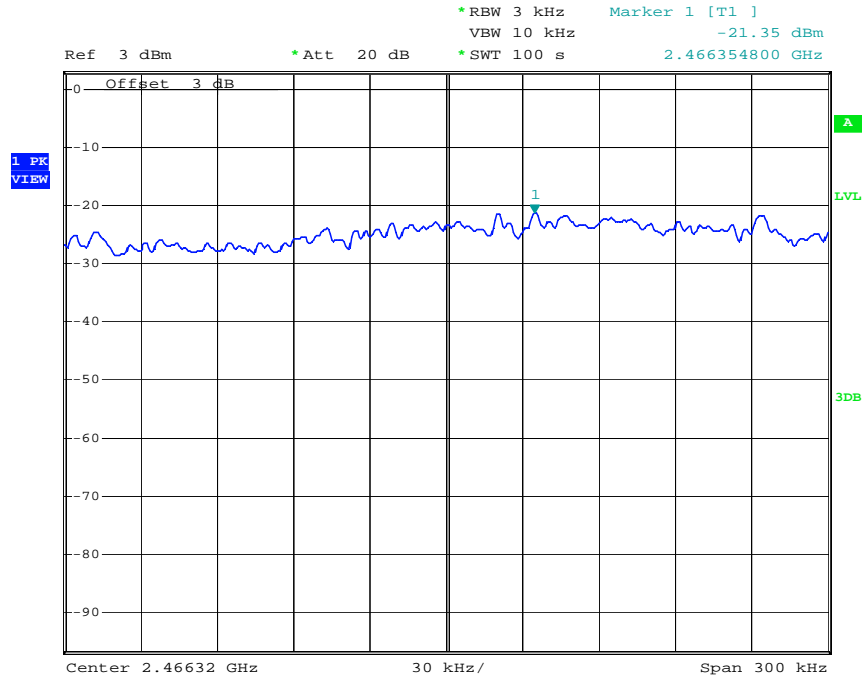

802.11n(HT40) mode with 150Mbps data rate

Channel 3: 2.422GHz:

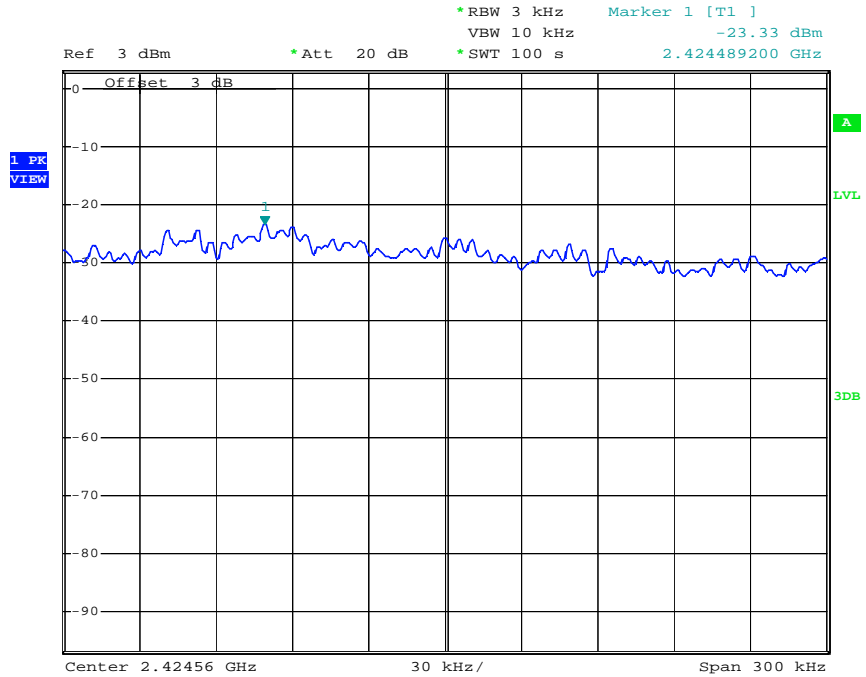

Channel 6: 2.437GHz:

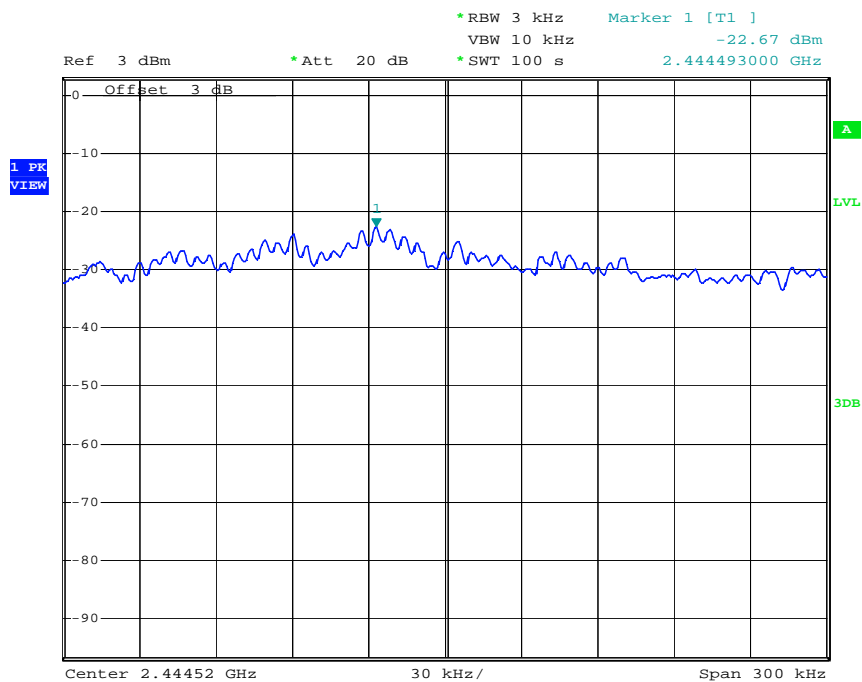

Channel 9: 2.452GHz:

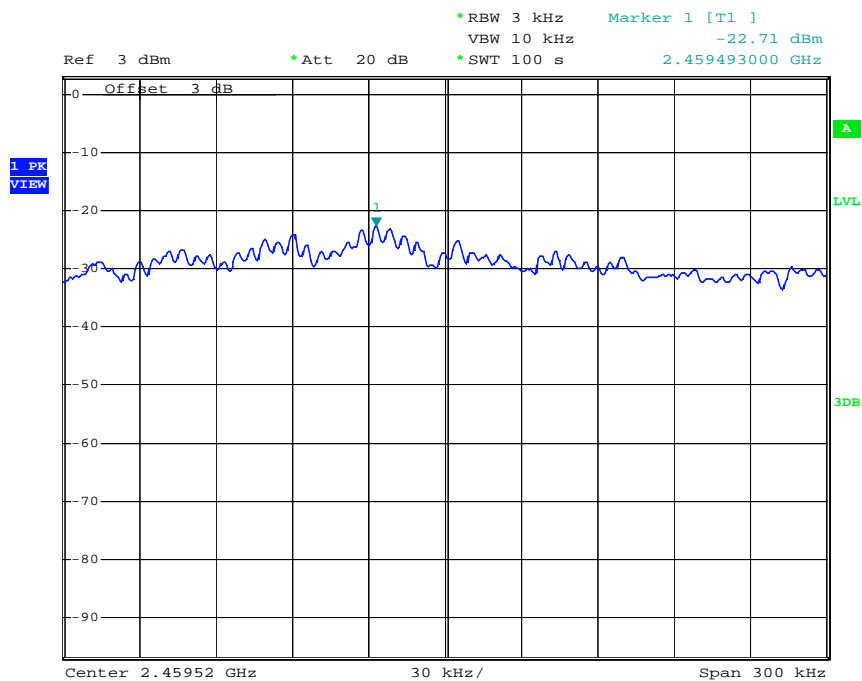

4.5 Out of Band Conducted Emissions

Test Requirement: FCC Part 15 C section 15.247
RSS-210 A8.5

(d) In any 100 kHz bandwidth outside the frequency band in which the spread spectrum or digitally modulated intentional radiator is operating. The radio frequency power that is produced by the intentional radiator shall be at least 20 dB below that in the 100 kHz bandwidth within the band that contains the highest level of the desired power. Based on either an RF conducted or a radiated measurement. Provided the transmitter demonstrates compliance with the peak conducted power limits.

Test Method: ANSI C63.10: Clause 6.7 & RSS-Gen clause 4.9

Test Status: Pre-Scan has been conducted to determine the worst-case mode from all possible combinations between available modulations, data rates and antenna ports (if EUT with antenna diversity architecture). Following channel(s) was (were) selected for the final test as listed below.

Test Configuration:

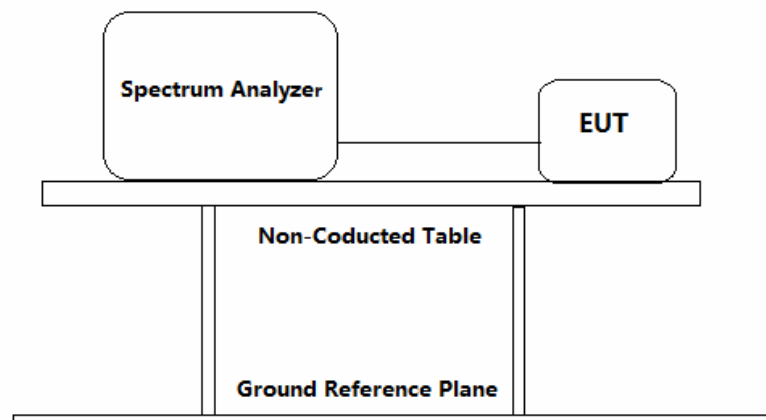

Test Procedure:

1. Remove the antenna from the EUT and then connect a low RF cable (cable loss =3dB) from the antenna port to the spectrum analyzer or power meter.
2. Set the spectrum analyzer: RBW=100 kHz, VBW = 300 kHz. Sweep = auto; Detector Function = Peak. Trace = Max Hold, Scan up through 10th harmonic.
3. Measure the Conducted unwanted Emissions of the test frequency with special test status.
4. Repeat until all the test status is investigated.
5. Report the worst case.

Result plot as follows:
802.11b mode with 11Mbps data rate
Channel 1: 2.412GHz:
30 MHz to 2 GHz:

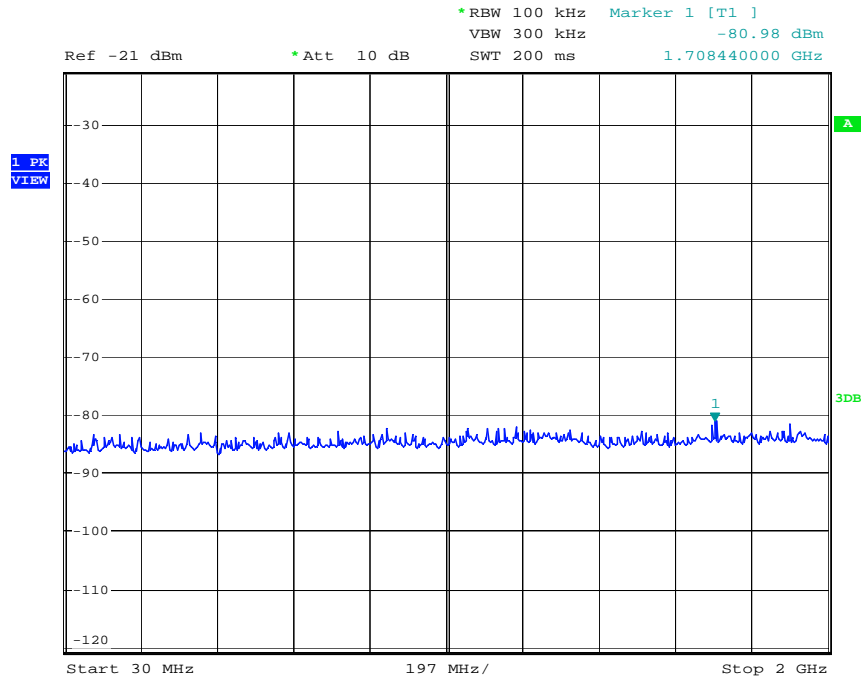

2 GHz to 10 GHz:

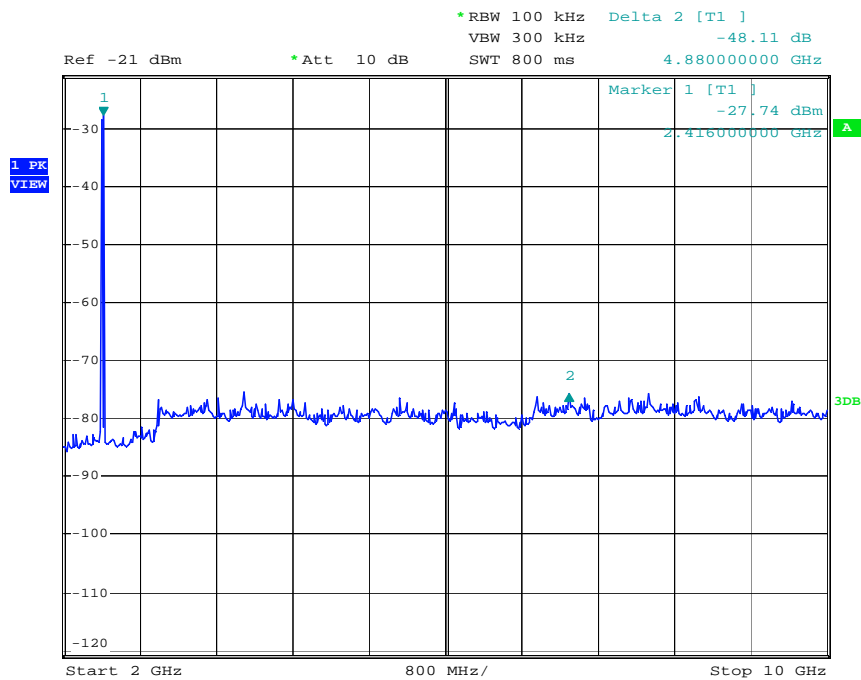

10 GHz to 25 GHz:

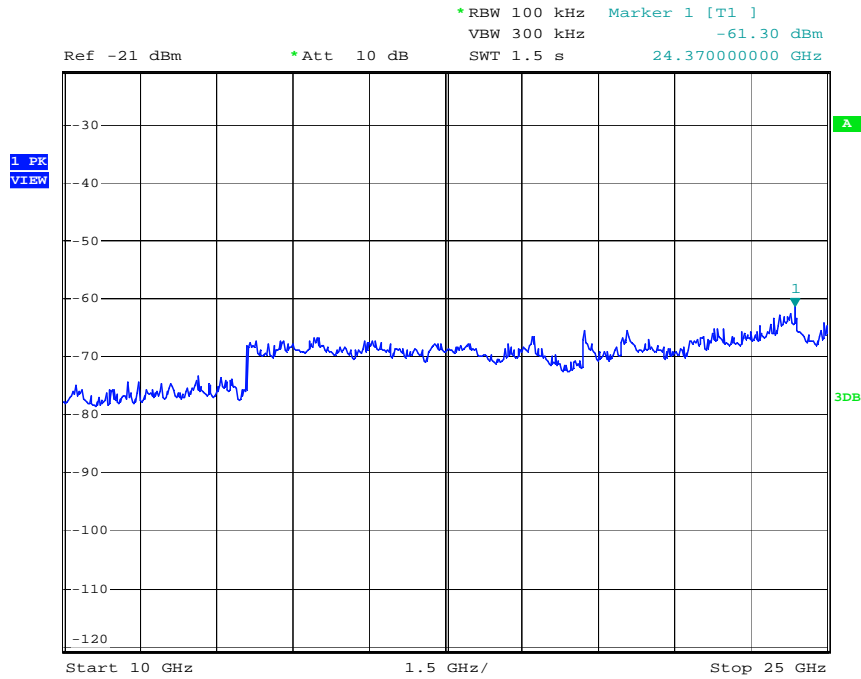

In any 100kHz bandwidth, the Conducted Spurious Emissions from 30 MHz to 25 GHz were greater than 20dB below the peak emission within the band that contains the highest level of the desired power.

802.11b mode with 11Mbps data rate

Channel 6: 2.437GHz:

30 MHz to 2 GHz:

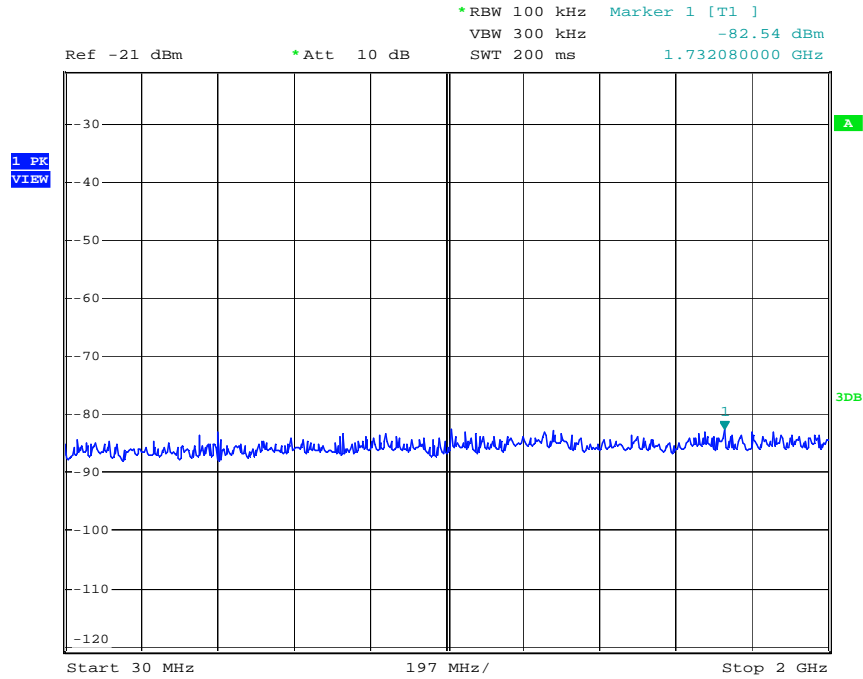

2 GHz to 10 GHz:

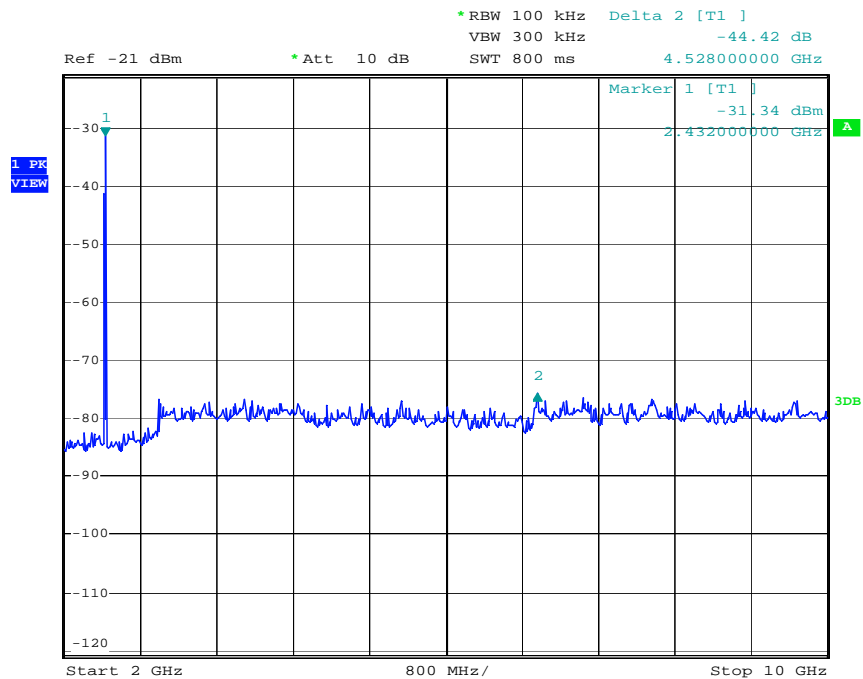

10 GHz to 25 GHz:

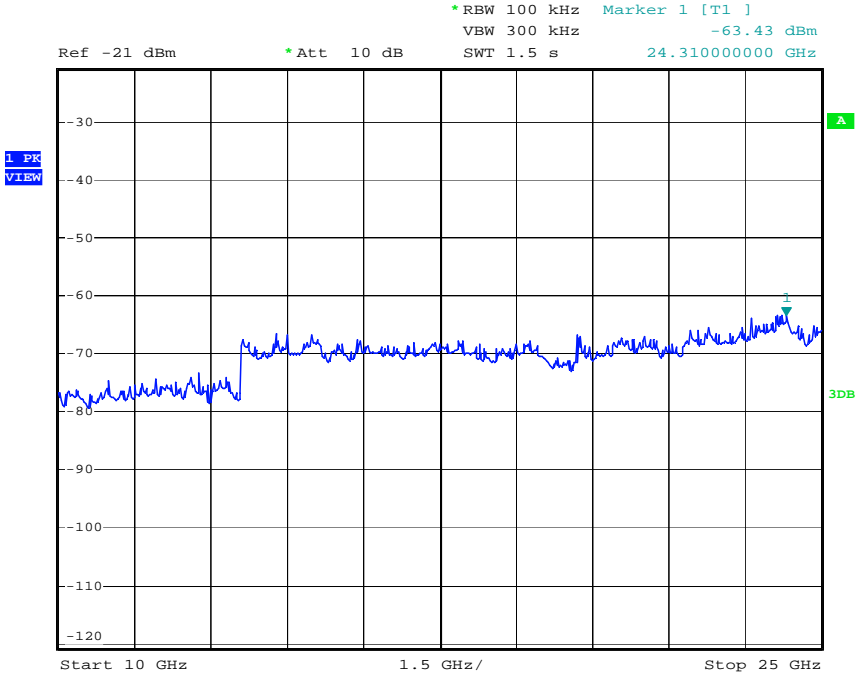

In any 100kHz bandwidth, the Conducted Spurious Emissions from 30 MHz to 25 GHz were greater than 20dB below the peak emission within the band that contains the highest level of the desired power.

Channel 11:2.462 GHz:

30 MHz to 2 GHz:

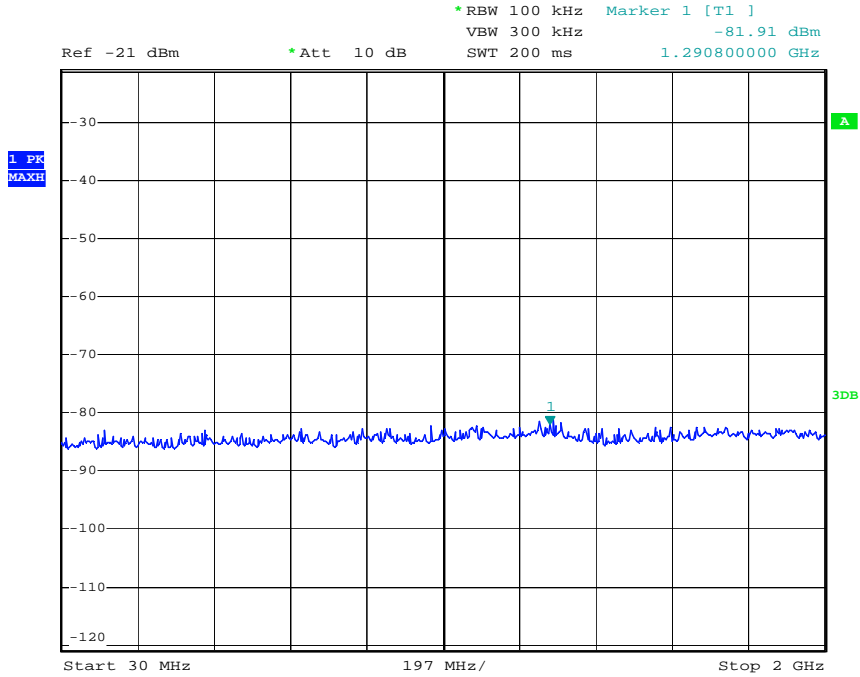

2 GHz to 10 GHz:

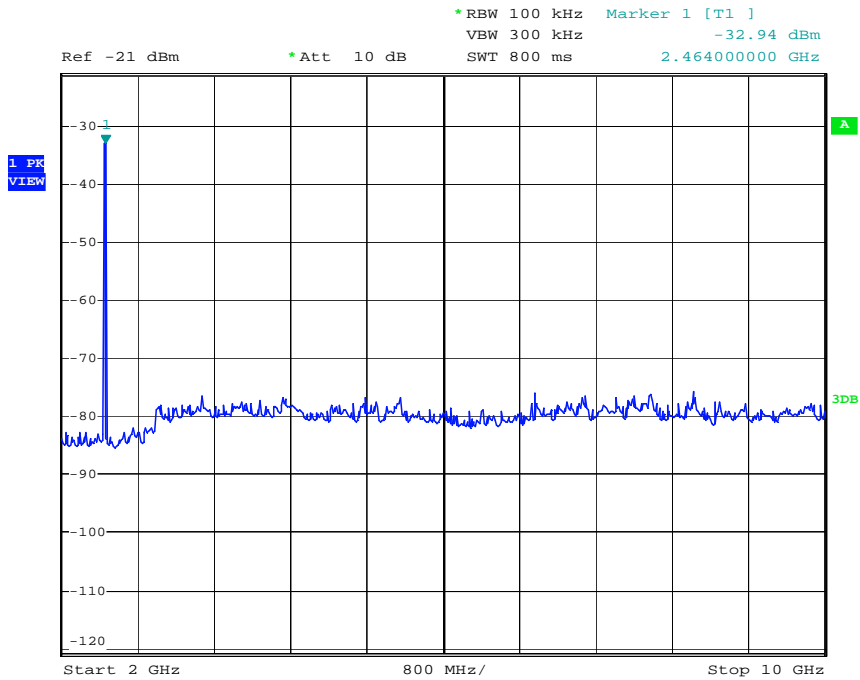

10 GHz to 25 GHz:

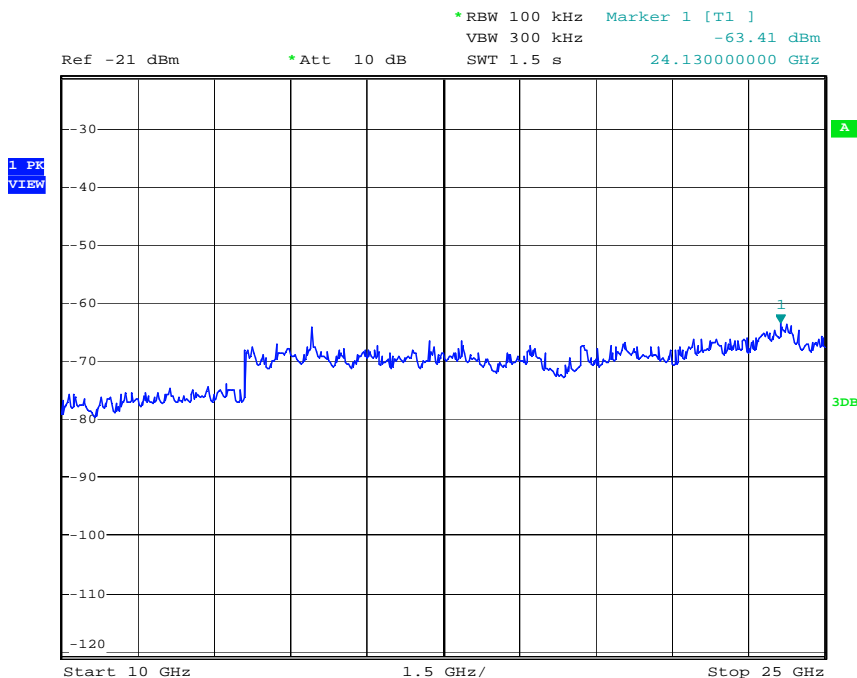

In any 100kHz bandwidth, the Conducted Spurious Emissions from 30 MHz to 25 GHz were greater than 20dB below the peak emission within the band that contains the highest level of the desired power.

802.11g mode with 54Mbps data rate

Channel 1: 2.412GHz:

30 MHz to 2 GHz:

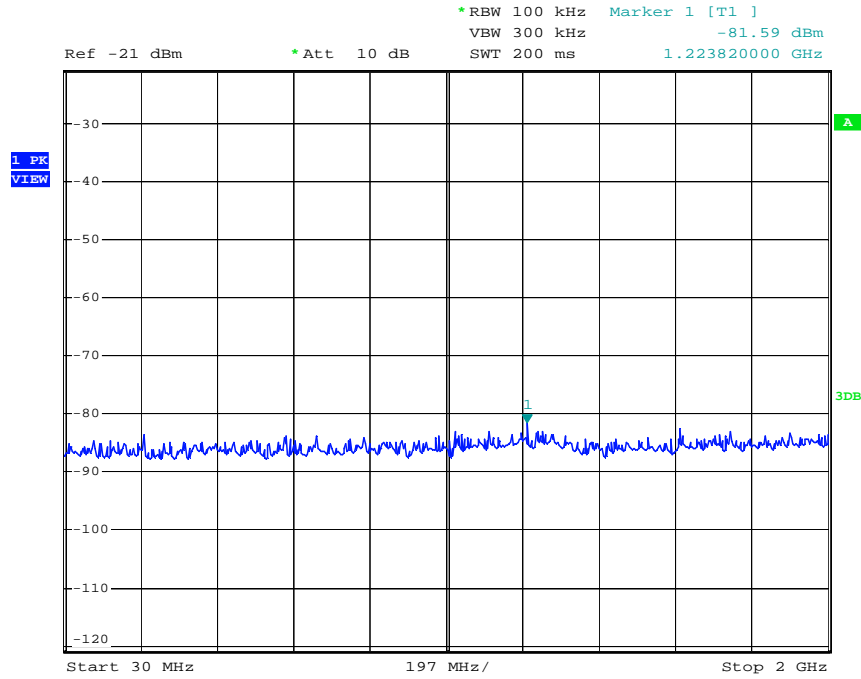

2 GHz to 10 GHz:

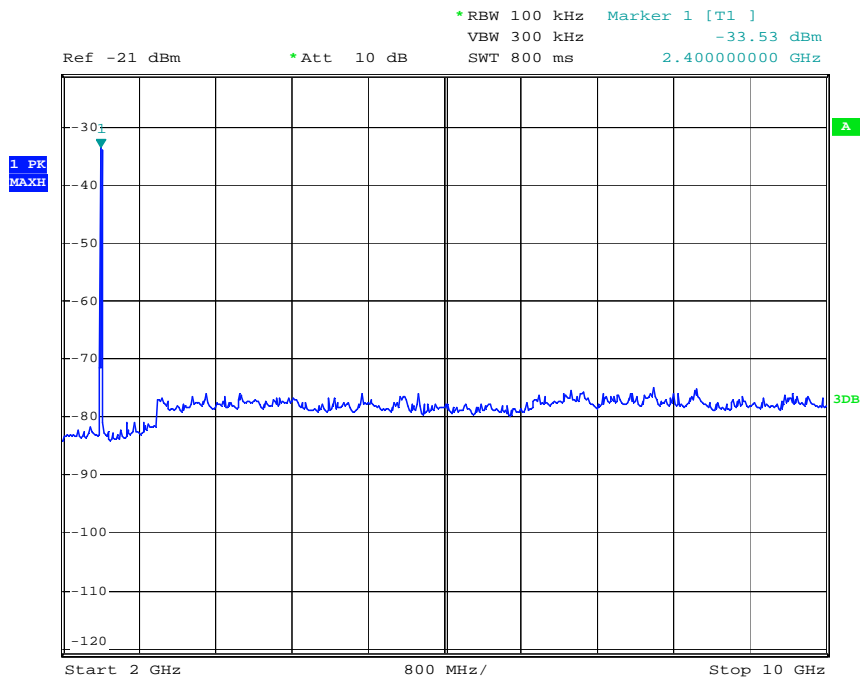

10 GHz to 25 GHz:

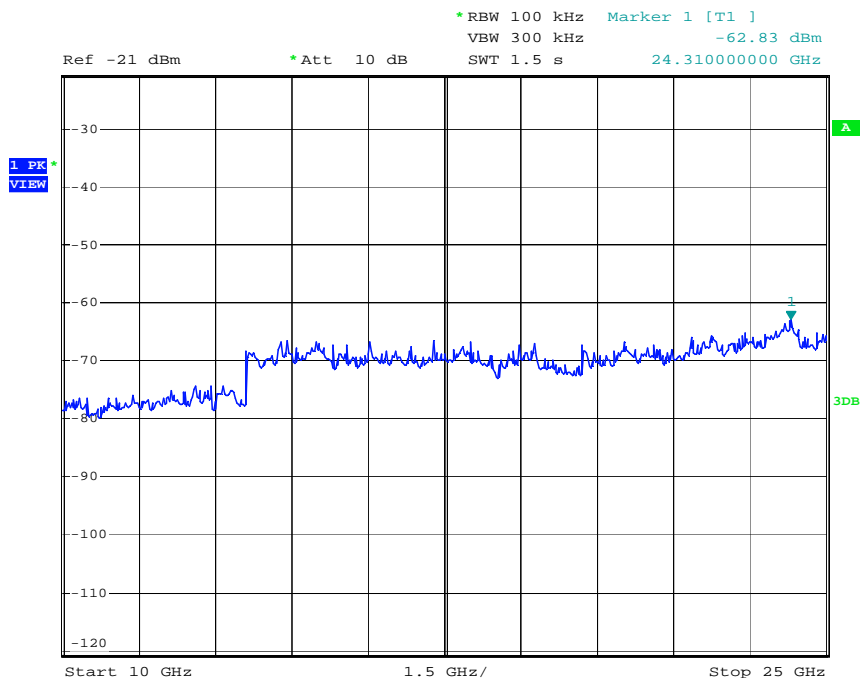

In any 100kHz bandwidth, the Conducted Spurious Emissions from 30 MHz to 25 GHz were greater than 20dB below the peak emission within the band that contains the highest level of the desired power.

Channel 6: 2.437GHz:

30 MHz to 2 GHz:

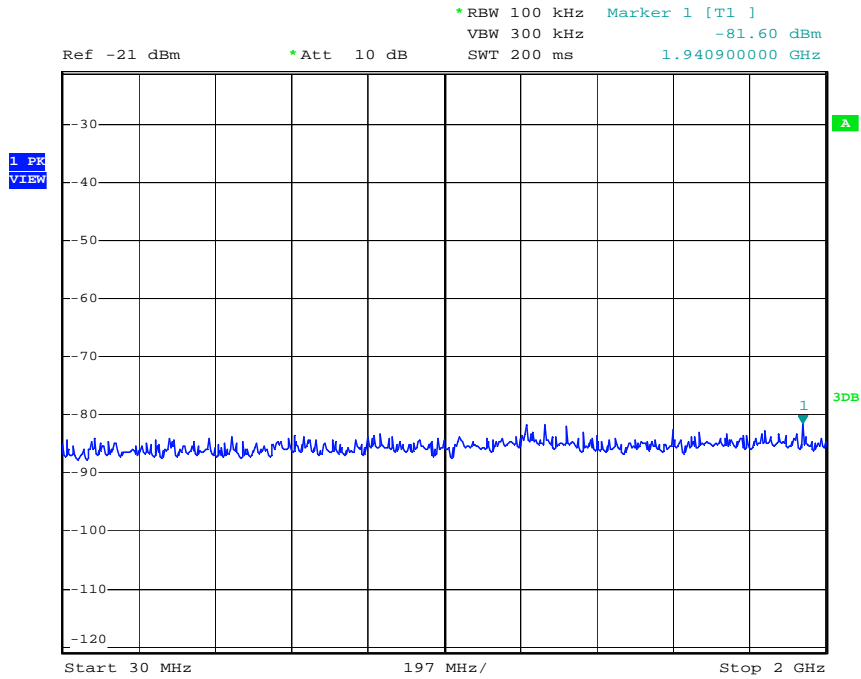

2 GHz to 10 GHz:

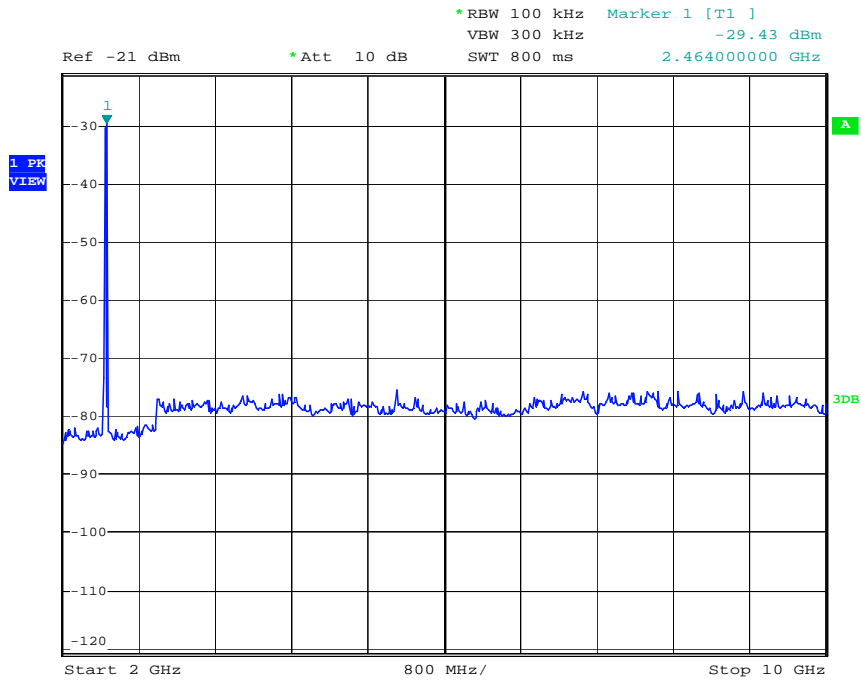

10 GHz to 25 GHz:

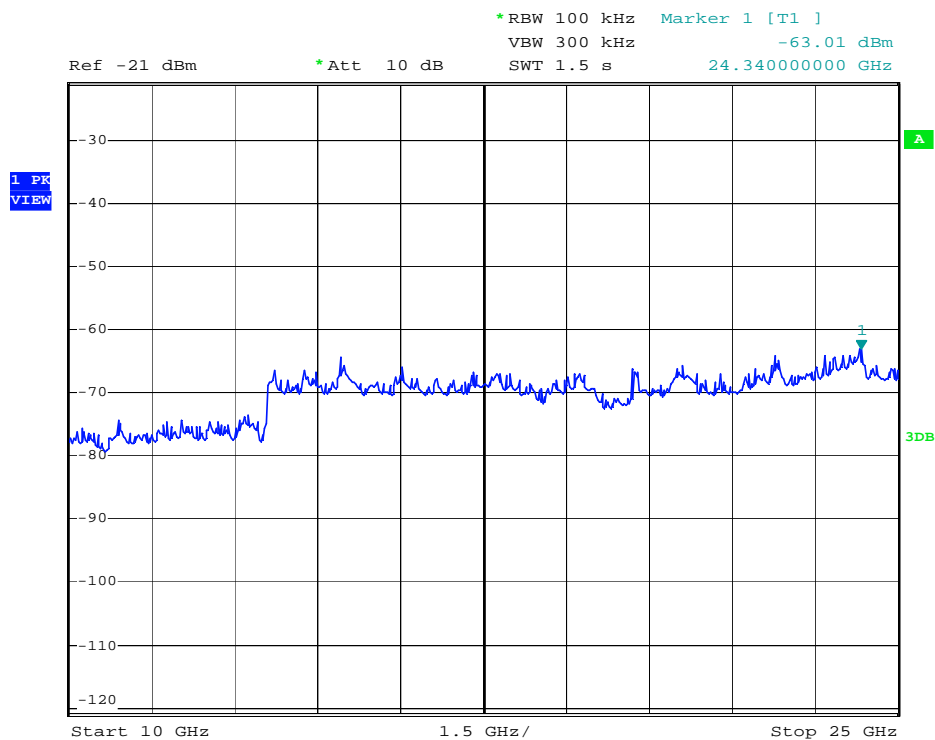

In any 100kHz bandwidth, the Conducted Spurious Emissions from 30 MHz to 25 GHz were greater than 20dB below the peak emission within the band that contains the highest level of the desired power.

Channel 11:2.462 GHz:

30 MHz to 2 GHz:

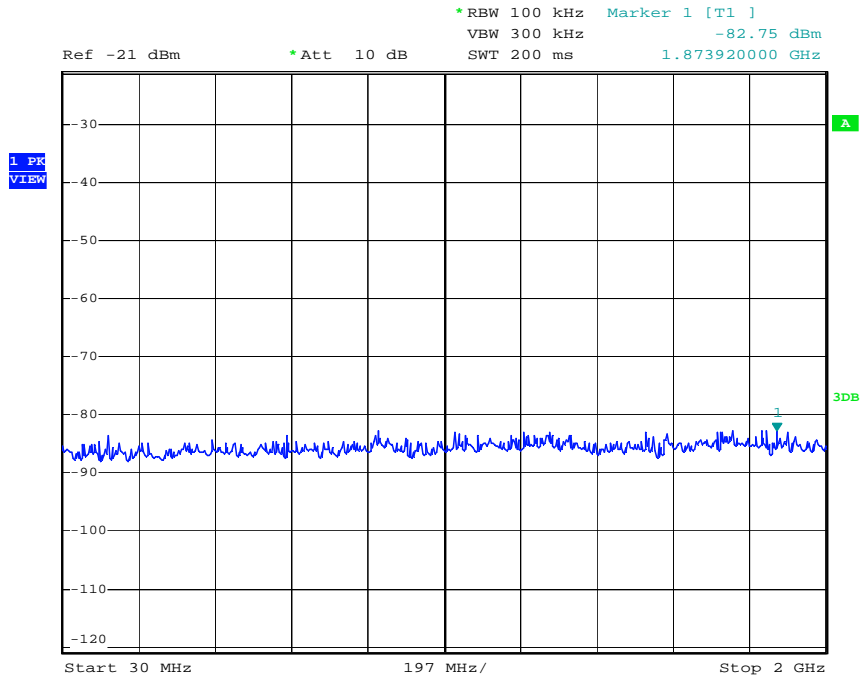

2 GHz to 10 GHz:

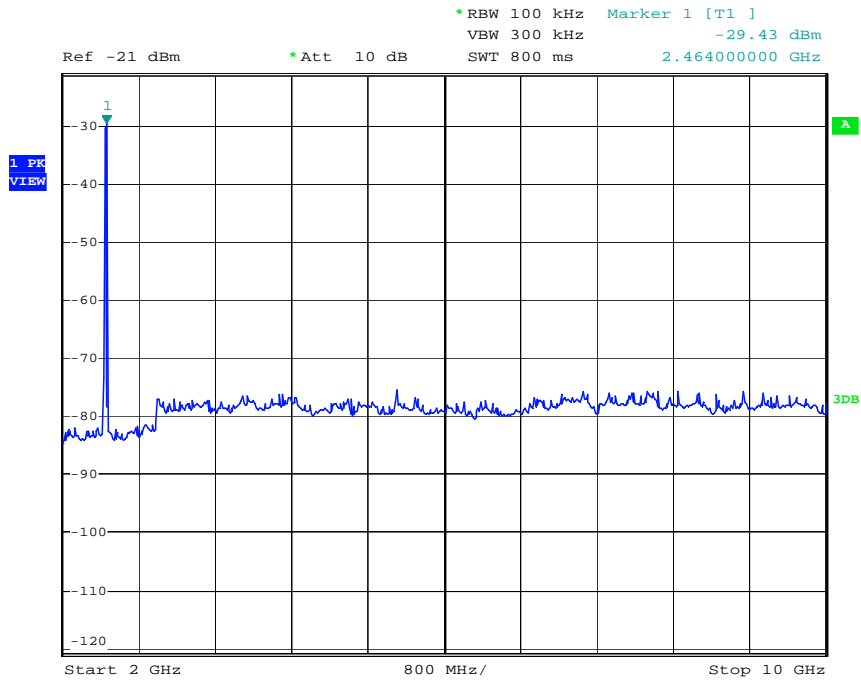

10 GHz to 25 GHz:

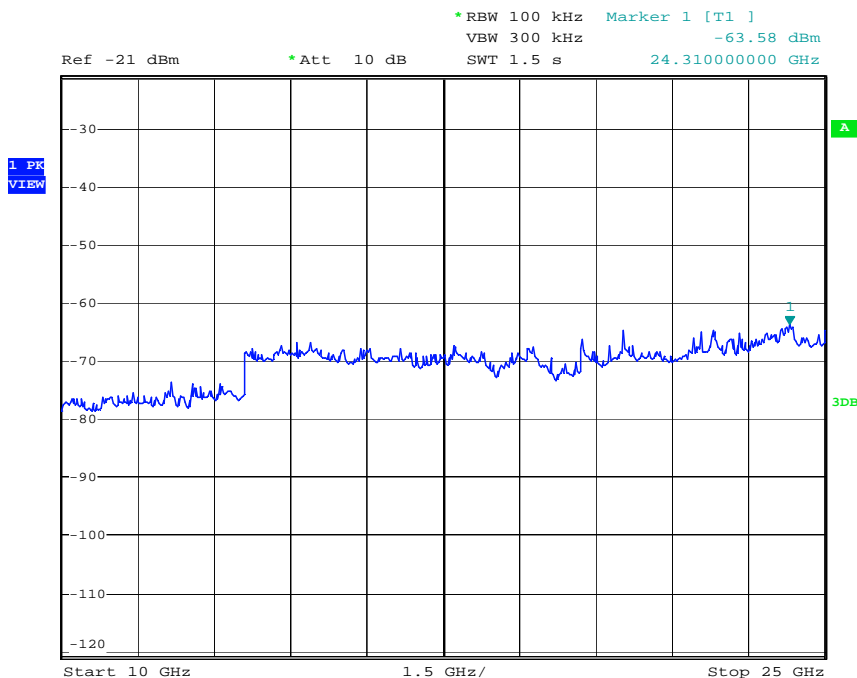

In any 100kHz bandwidth, the Conducted Spurious Emissions from 30 MHz to 25 GHz were greater than 20dB below the peak emission within the band that contains the highest level of the desired power.

802.11n(HT20) mode with 72.2Mbps data rate

Channel 1: 2.412GHz:

30 MHz to 2 GHz:

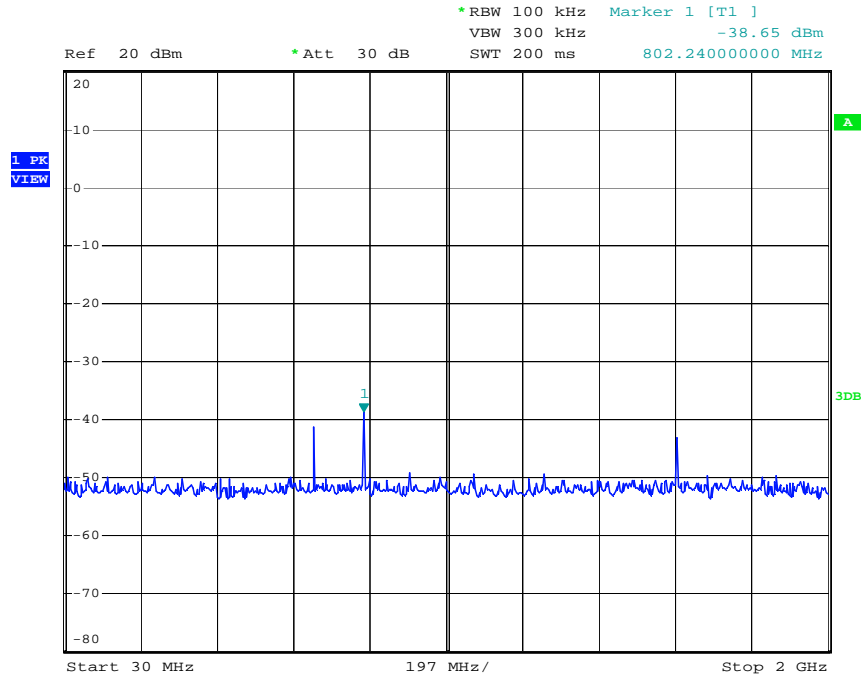

2 GHz to 10 GHz:

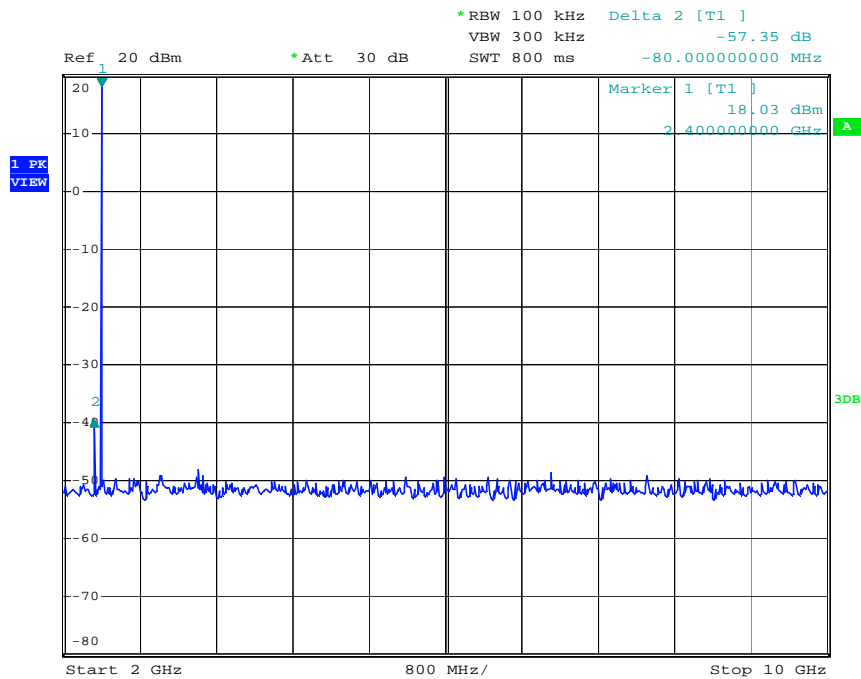

10 GHz to 25 GHz:

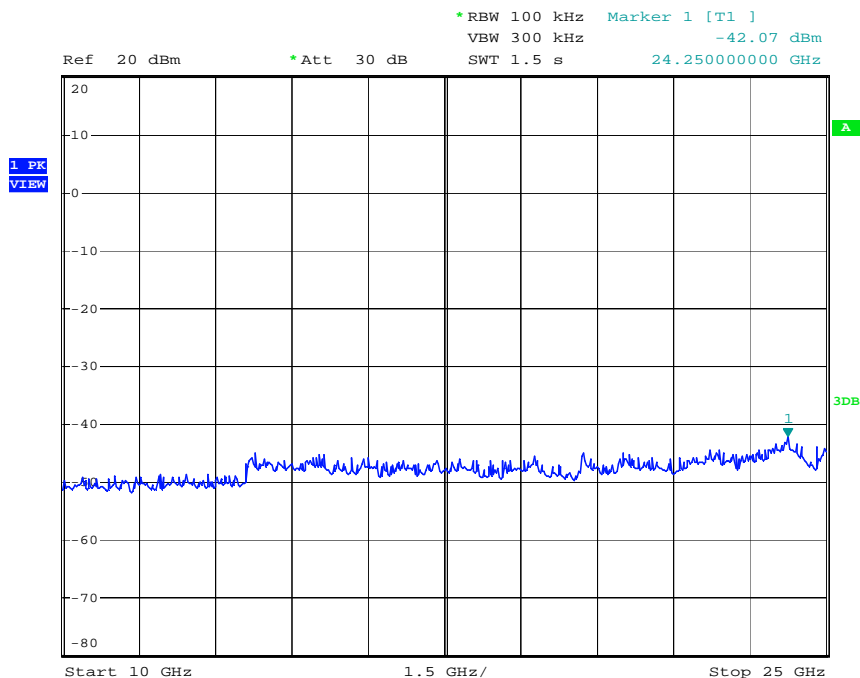

In any 100kHz bandwidth, the Conducted Spurious Emissions from 30 MHz to 25 GHz were greater than 20dB below the peak emission within the band that contains the highest level of the desired power.

Channel 6: 2.437GHz:

30 MHz to 2 GHz:

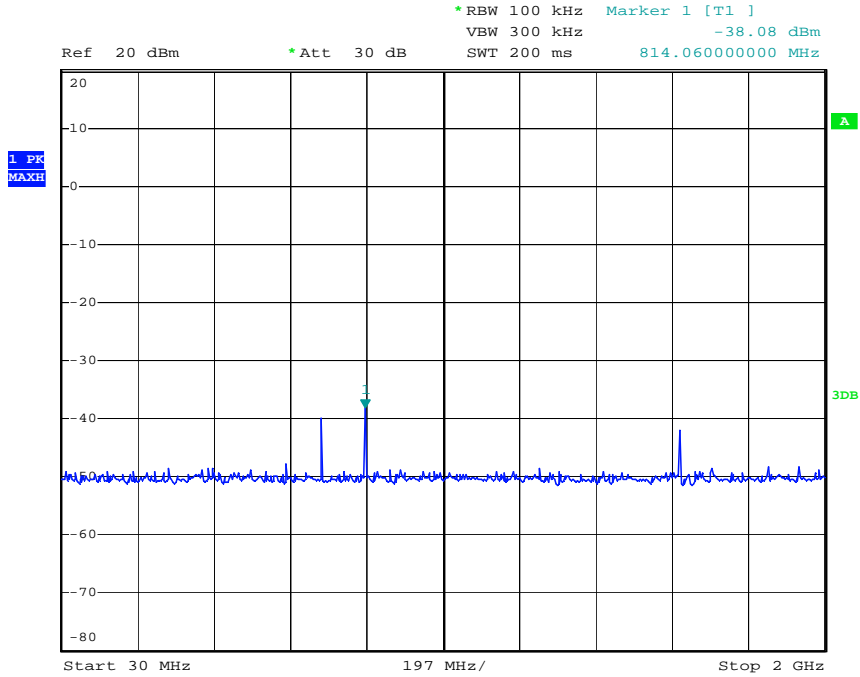

2 GHz to 10 GHz:

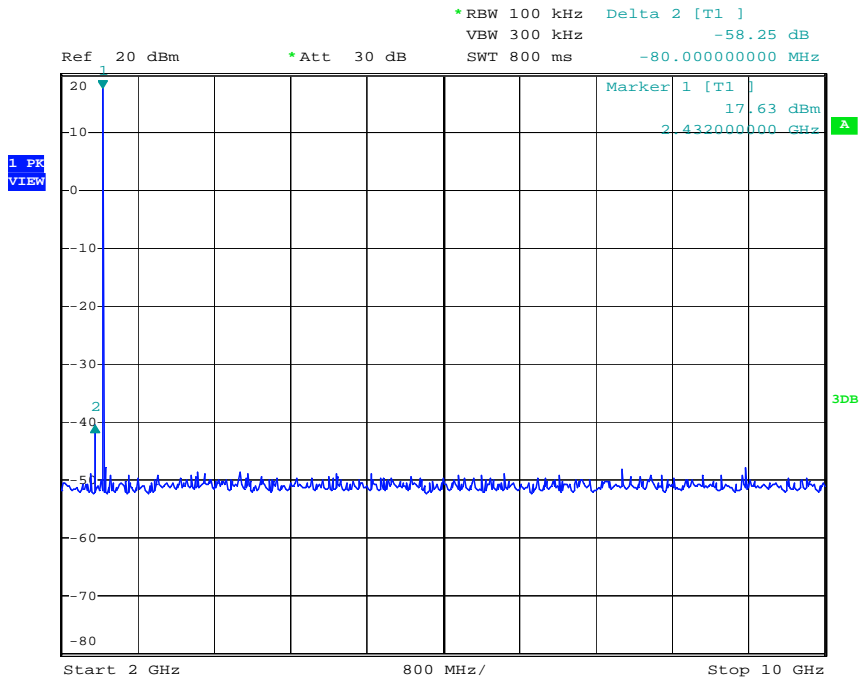

10 GHz to 25 GHz:

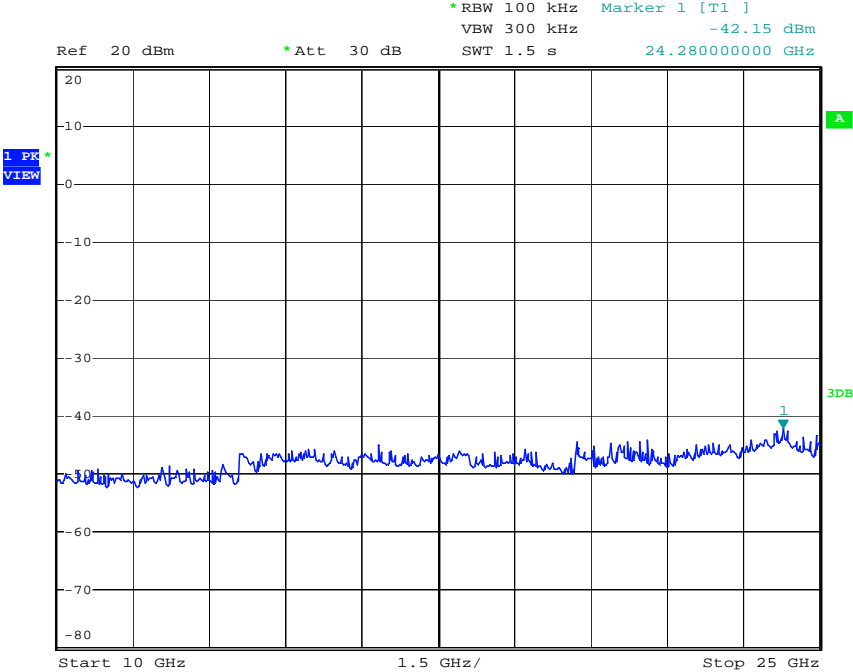

In any 100kHz bandwidth, the Conducted Spurious Emissions from 30 MHz to 25 GHz were greater than 20dB below the peak emission within the band that contains the highest level of the desired power.

Channel 11:2.462 GHz:

30 MHz to 2 GHz:

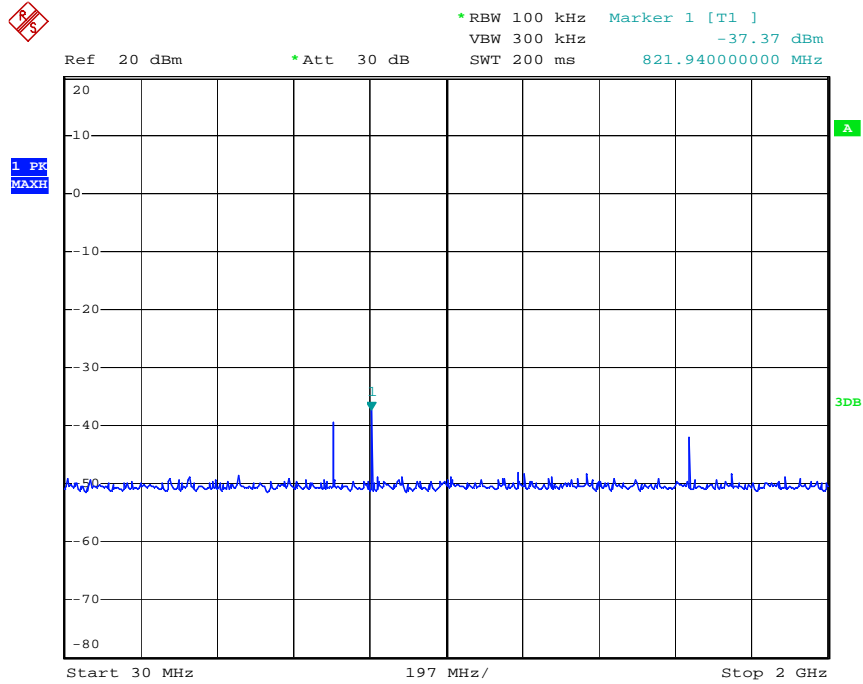

2 GHz to 10 GHz:

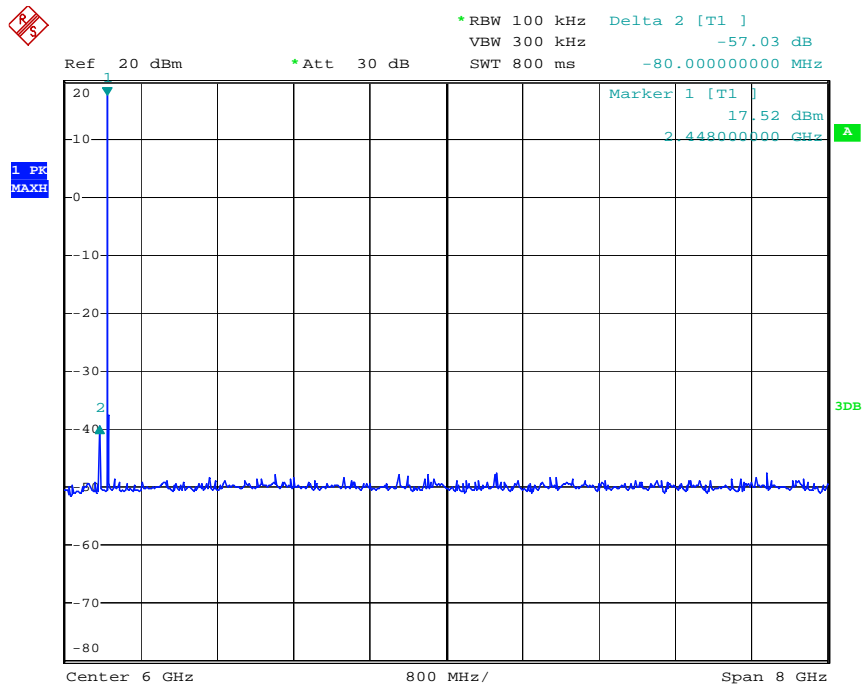



Report No.: 141121032GZU-001
Issued: 2015-01-08

10 GHz to 25 GHz:

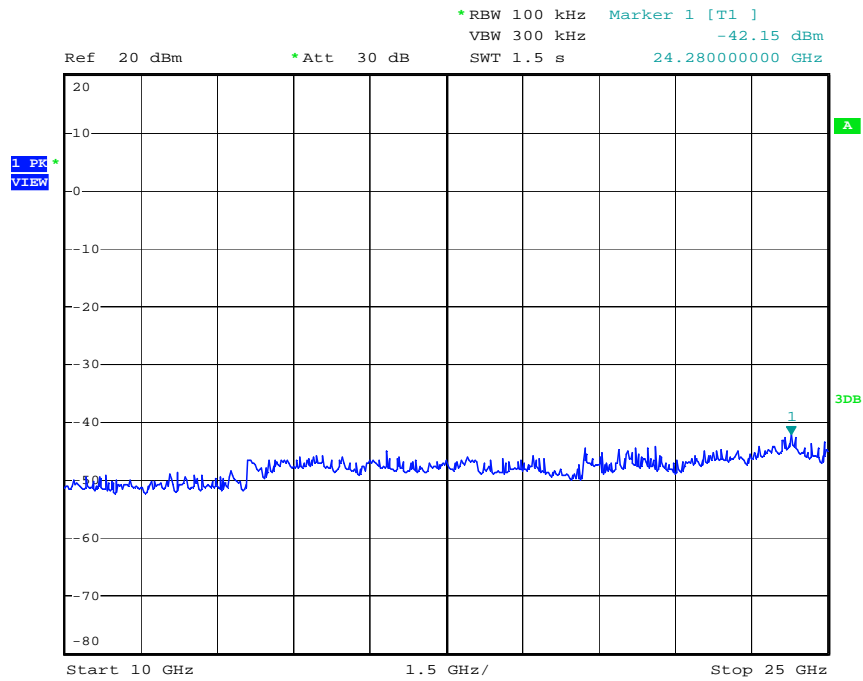

In any 100kHz bandwidth, the Conducted Spurious Emissions from 30 MHz to 25 GHz were greater than 20dB below the peak emission within the band that contains the highest level of the desired power.

802.11n(HT40) mode with 150Mbps data rate

Channel 3: 2.422GHz:

30 MHz to 2 GHz:

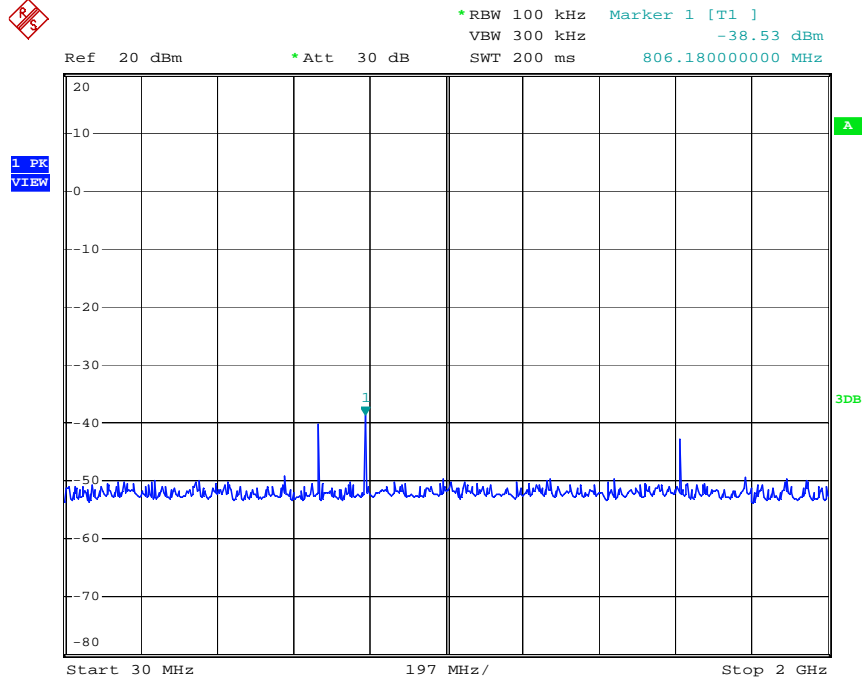

2 GHz to 10 GHz:

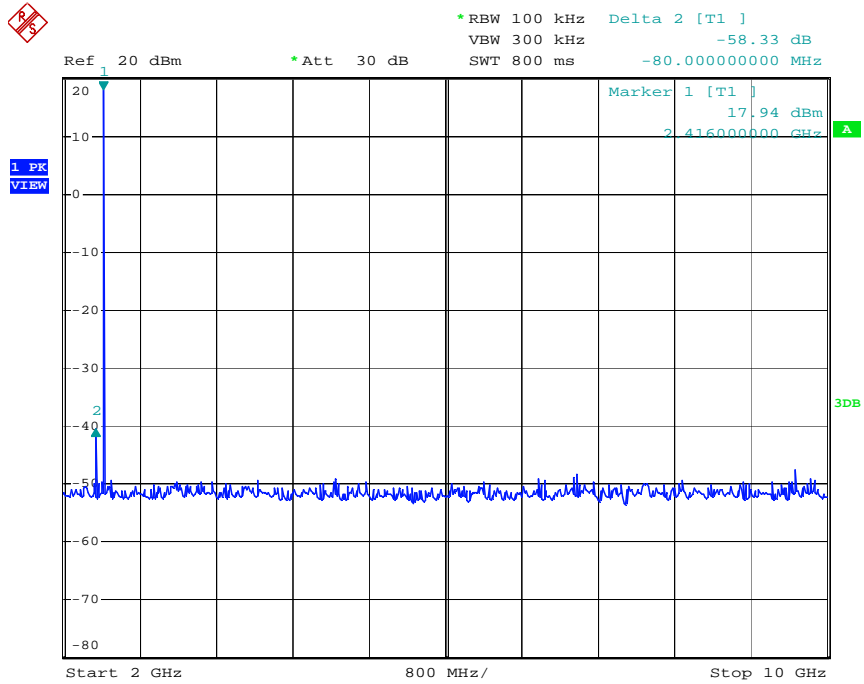

10 GHz to 25 GHz:

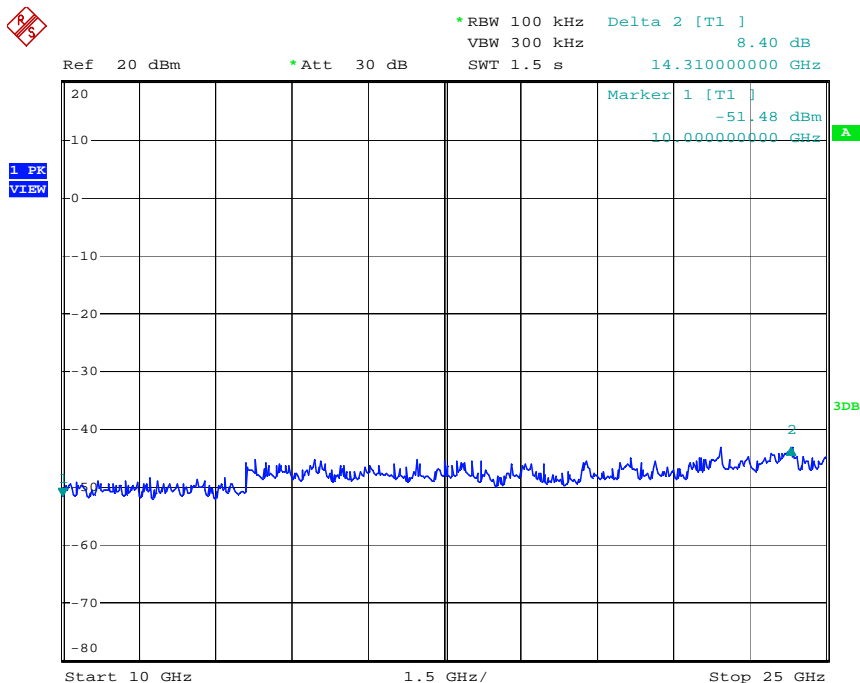

In any 100kHz bandwidth, the Conducted Spurious Emissions from 30 MHz to 25 GHz were greater than 20dB below the peak emission within the band that contains the highest level of the desired power.

Channel 6: 2.437GHz:

30 MHz to 2 GHz:

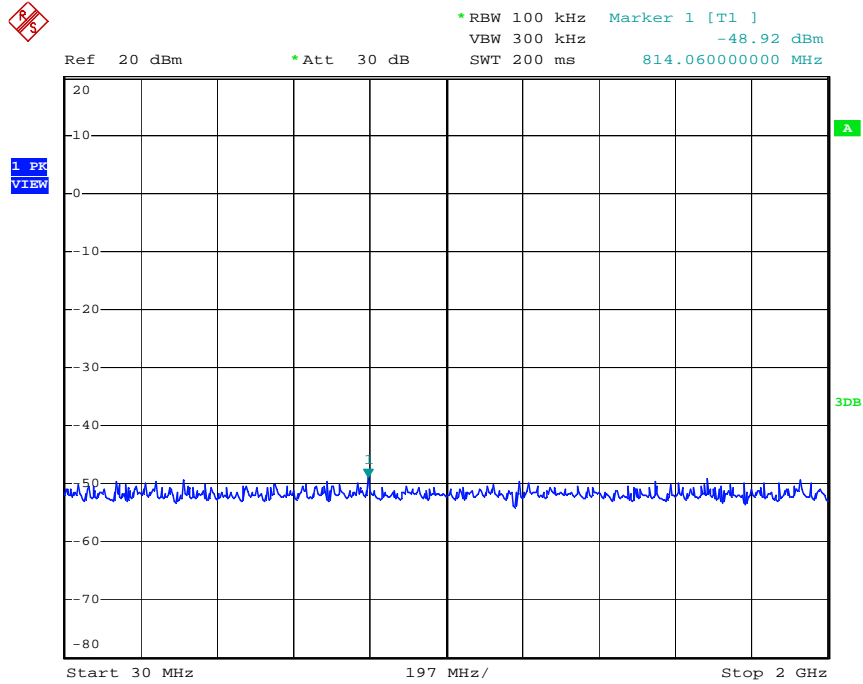

2 GHz to 10 GHz:

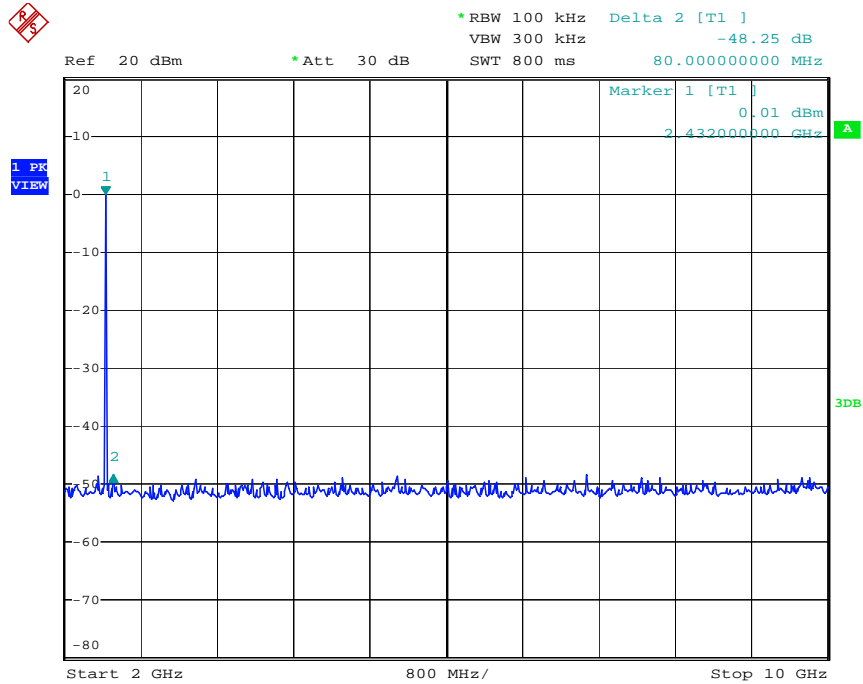

10 GHz to 25 GHz:

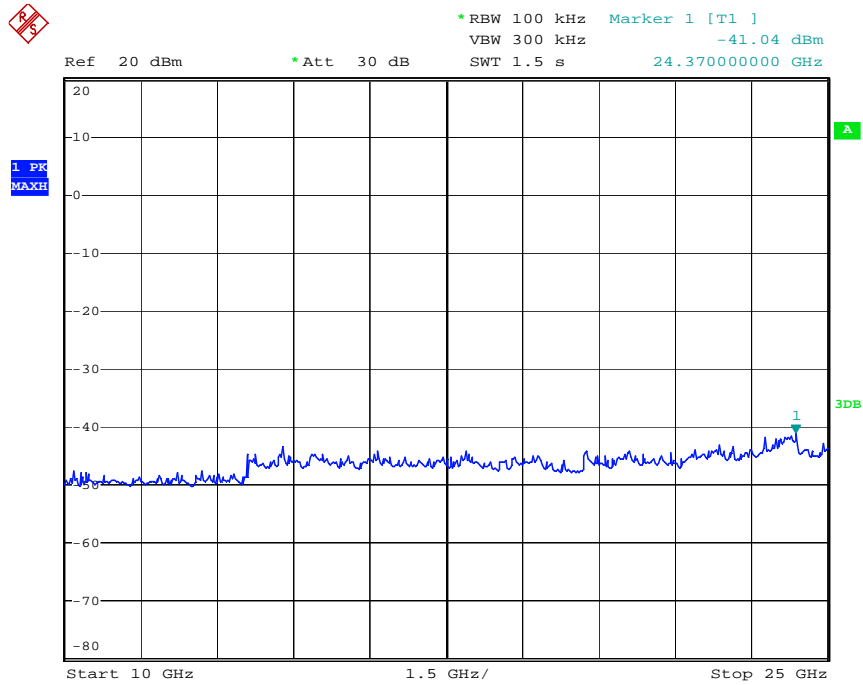

In any 100kHz bandwidth, the Conducted Spurious Emissions from 30 MHz to 25 GHz were greater than 20dB below the peak emission within the band that contains the highest level of the desired power.

Channel 9: 2.452 GHz:

30 MHz to 2 GHz:

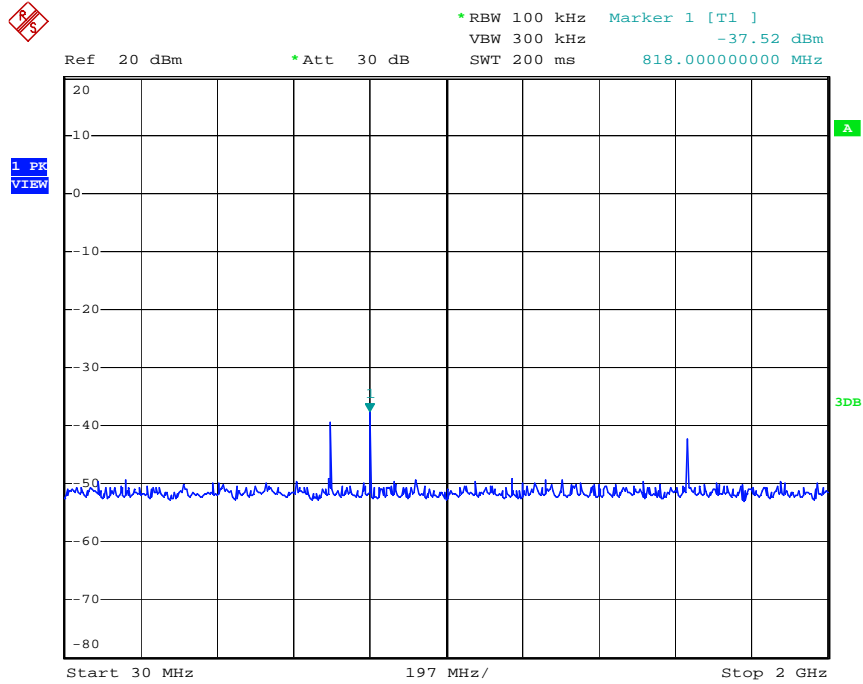

2 GHz to 10 GHz:

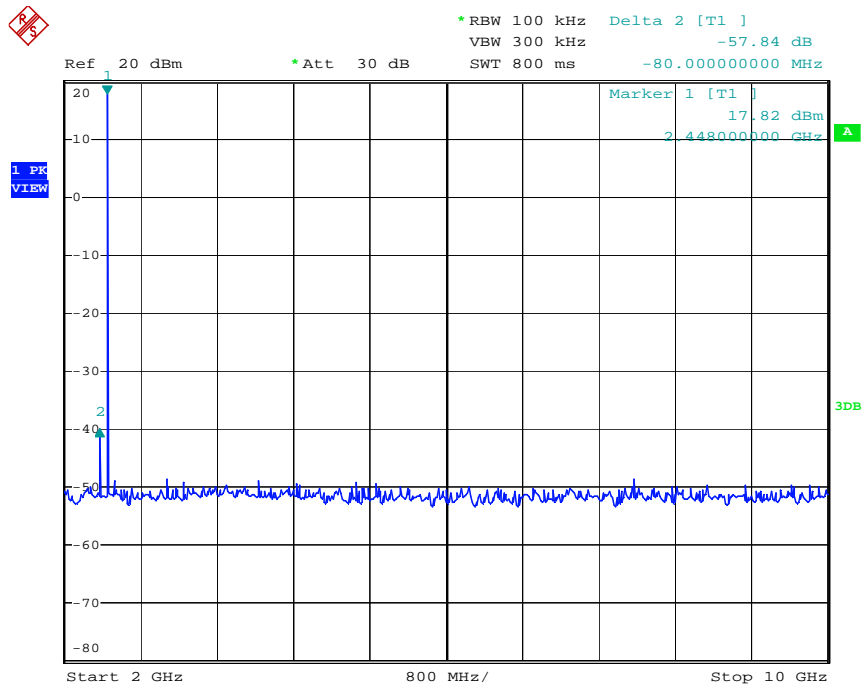

10 GHz to 25 GHz:

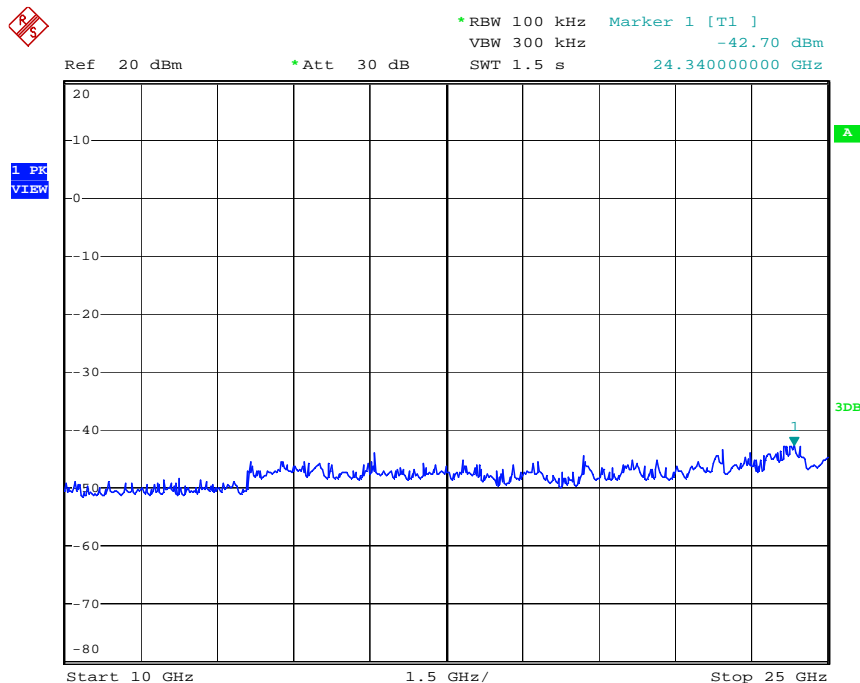

In any 100kHz bandwidth, the Conducted Spurious Emissions from 30 MHz to 25 GHz were greater than 20dB below the peak emission within the band that contains the highest level of the desired power.



Report No.: 141121032GZU-001
Issued: 2015-01-08

4.6 Out of Band Radiated Emissions

For out of band radiated emissions into Non-Restricted Frequency Bands were performed at a 3m separation distance to determine whether these emissions complied with the 20dB attenuation requirement.

- Not required, since all emissions are more than 20dB below fundamental
- See attached data sheet

4.7 Radiated Emissions in Restricted Bands

Test Requirement:	<p>FCC Part 15 C section 15.247 RSS-210 clause 2.2</p> <p>(d) In addition, radiated emissions which fall in the restricted bands, as defined in Section 15.205(a), must also comply with the radiated emission limits specified in Section 15.209(a) (see Section 15.205(c)).</p> <p>Category I licence-exempt equipment is required to comply with the provisions in RSS-Gen with respect to emissions falling within restricted frequency bands. These restricted frequency bands are listed in RSS-Gen.</p>
Test Method:	ANSI C63.10: Clause 6.4, 6.5 and 6.6 & RSS-Gen clause 4.9
Test Status:	Pre-Scan has been conducted to determine the worst-case mode from all possible combinations between available modulations, data rates and antenna ports (if EUT with antenna diversity architecture). Following channel(s) was (were) selected for the final test as listed below.
Test site:	Measurement Distance: 3m (Semi-Anechoic Chamber)
Limit:	<p>40.0 dBμV/m between 30MHz & 88MHz;</p> <p>43.5 dBμV/m between 88MHz & 216MHz;</p> <p>46.0 dBμV/m between 216MHz & 960MHz;</p> <p>54.0 dBμV/m above 960MHz.</p>
Detector:	<p>For Peak and Quasi-Peak value:</p> <p>RBW =</p> <p>1 MHz for $f \geq 1$ GHz,</p> <p>200 Hz for 9 kHz to 150 kHz</p> <p>9 kHz for 150 kHz to 30 MHz</p> <p>120 kHz for 30 MHz to 1GHz</p> <p>VBW \geq RBW</p> <p>Sweep = auto</p> <p>Detector function = peak for $f \geq 1$ GHz, QP for $f < 1$ GHz</p> <p>Trace = max hold</p> <p>For AV value:</p> <p>RBW = 1 MHz for $f \geq 1$ GHz, 100 kHz for $f < 1$ GHz</p> <p>VBW=10 Hz</p> <p>Sweep = auto</p> <p>Trace = max hold</p>

Section 15.205 Restricted bands of operation.

(a) Except as shown in paragraph (d) of this section. Only spurious emissions are permitted in any of the frequency bands listed below:

MHz	MHz	MHz	GHz
0.090 - 0.110	16.42 - 16.423	399.9 - 410	4.5 - 5.15
¹ 0.495 - 0.505	16.69475 -	608 - 614	5.35 - 5.46
2.1735 - 2.1905	16.69525	960 - 1240	7.25 - 7.75
4.125 - 4.128	16.80425 -	1300 - 1427	8.025 - 8.5
4.17725 - 4.17775	16.80475	1435 - 1626.5	9.0 - 9.2
4.20725 - 4.20775	25.5 - 25.67	1645.5 - 1646.5	9.3 - 9.5
6.215 - 6.218	37.5 - 38.25	1660 - 1710	10.6 - 12.7
6.26775 - 6.26825	73 - 74.6	1718.8 - 1722.2	13.25 - 13.4
6.31175 - 6.31225	74.8 - 75.2	2200 - 2300	14.47 - 14.5
8.291 - 8.294	108 - 121.94	2310 - 2390	15.35 - 16.2
8.362 - 8.366	123 - 138	2483.5 - 2500	17.7 - 21.4
8.37625 - 8.38675	149.9 - 150.05	2655 - 2900	22.01 - 23.12
8.41425 - 8.41475	156.52475 -	3260 - 3267	23.6 - 24.0
12.29 - 12.293	156.52525	3332 - 3339	31.2 - 31.8
12.51975 -	156.7 - 156.9	3345.8 - 3358	36.43 - 36.5
12.52025	162.0125 - 167.17	3600 - 4400	
12.57675 -	167.72 - 173.2		
12.57725	240 - 285		
13.36 - 13.41	322 - 335.4		

Test Configuration:

1) 30 MHz to 1 GHz emissions:

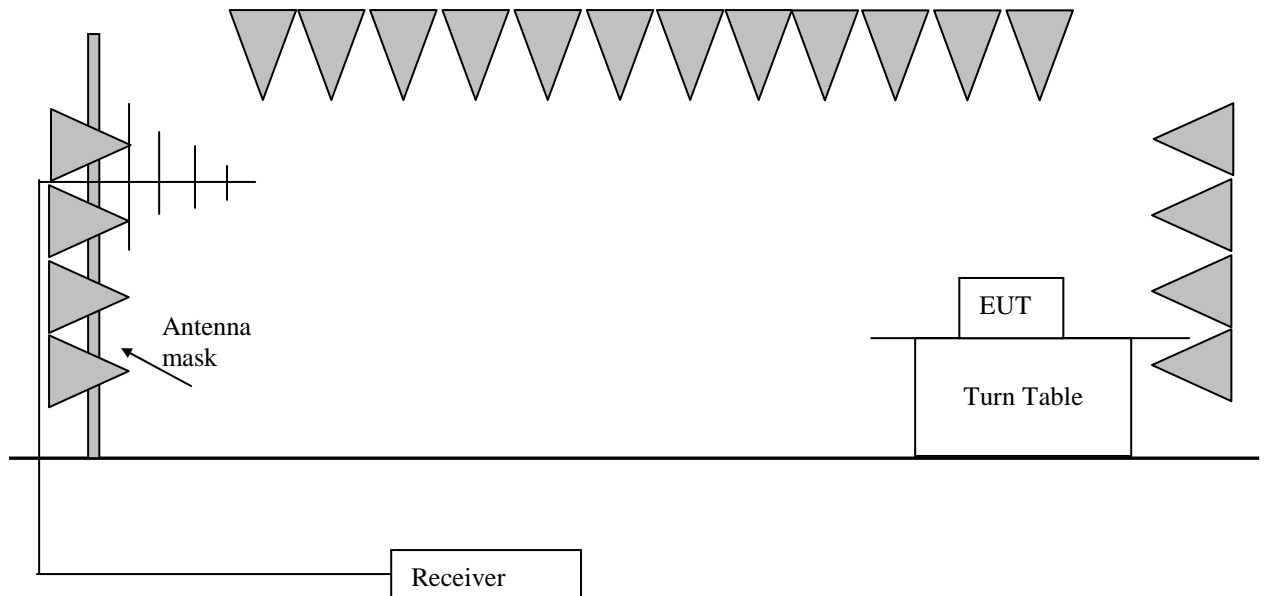

2) 1 GHz to 40 GHz emissions:

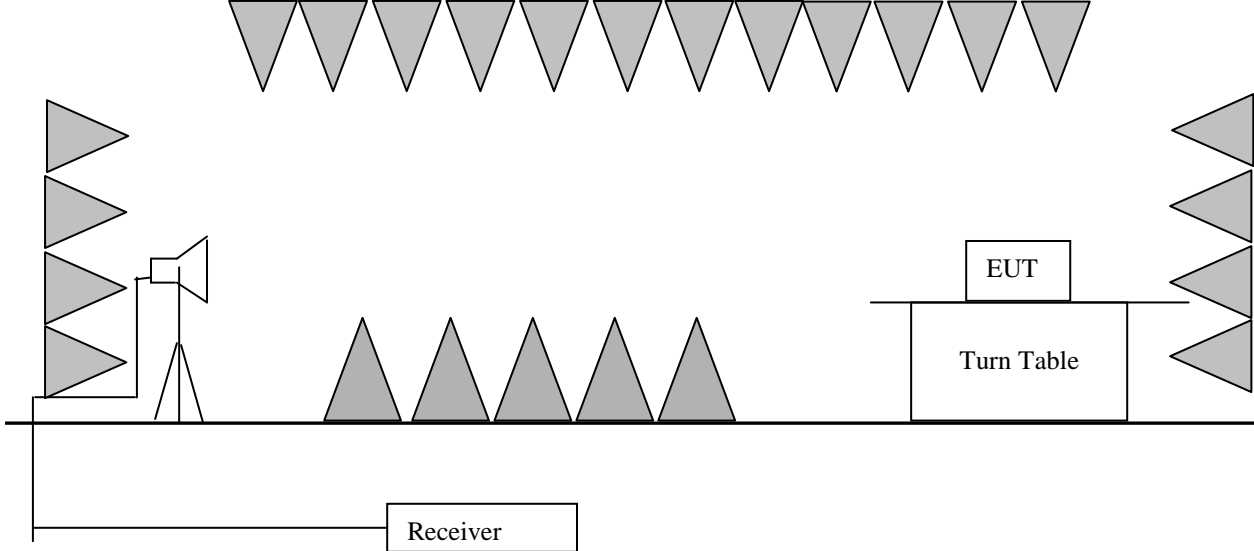

Test Procedure:

Test site with RF absorbing material covering the ground plane that met the site validation criterion called out in CISPR 16-1-4:2007 was used to perform radiated emission test above 1 GHz.

The receiver was scanned from 9 kHz to 25 GHz. When an emission was found, the table was rotated to produce the maximum signal strength. An initial pre-scan was performed for in peak detection mode using the receiver. The EUT was measured for both the Horizontal and Vertical polarities and performed a pre-test three orthogonal planes. For intentional radiators, measurements of the variation of the input power or the radiated signal level of the fundamental frequency component of the emission, as appropriate, shall be performed with the supply voltage varied between 85% and 115% of the nominal rated supply voltage. The worst case emissions were reported.

802.11b mode with 11Mbps data rate

9 kHz~30 MHz Field Strength of Unwanted Emissions for Quasi-Peak Measurement

The measurements with active loop antenna were greater than 20dB below the limit, so the test data were not recorded in the test report.

Test at Channel 1 (2.412 GHz) in transmitting status.

30 MHz~1 GHz Spurious Emissions .Quasi-Peak Measurement.

Vertical:

Level (dB μ V/m)

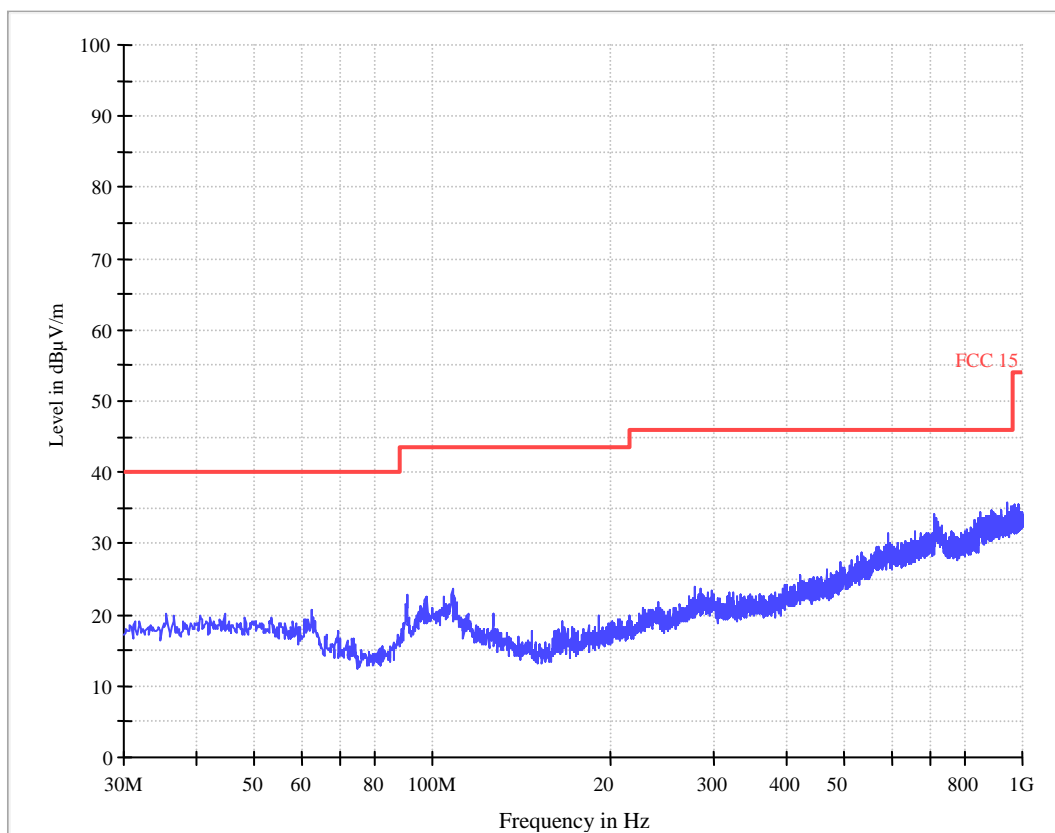

Horizontal:
Level (dB μ V/m)

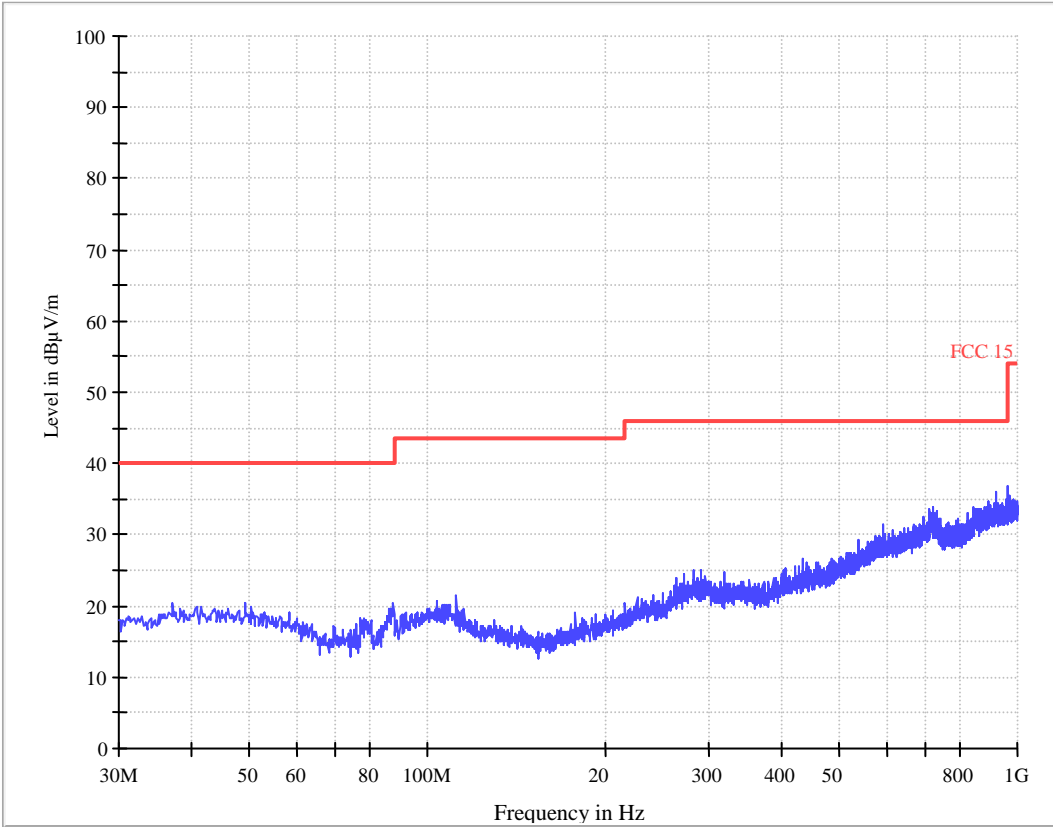



1~25 GHz Radiated Emissions.

PK Measurement:

Frequency (MHz)	PK Reading Level (dB μ V)	Correction factors (dB/m)	PK Emission Level (dB μ V/m)	AV Limit (dB μ V/m)	Antenna polarization
2344.7388	51.965	-7.5	44.465	54	V
2354.1038	54.187	-7.5	46.687	54	V
2364.5538	52.782	-7.4	45.382	54	V
2492.4238	55.033	-6.9	48.133	54	H
2495.8675	56.054	-6.9	49.154	54	H
2498.8125	55.718	-6.9	48.818	54	H

Remark: When Peak emission level was below AV limit, the AV emission level did not be recorded.

Test at Channel 6 (2.437 GHz) in transmitting status.
30 MHz~1 GHz Spurious Emissions .Quasi-Peak Measurement.

Vertical:

Level (dB μ V/m)

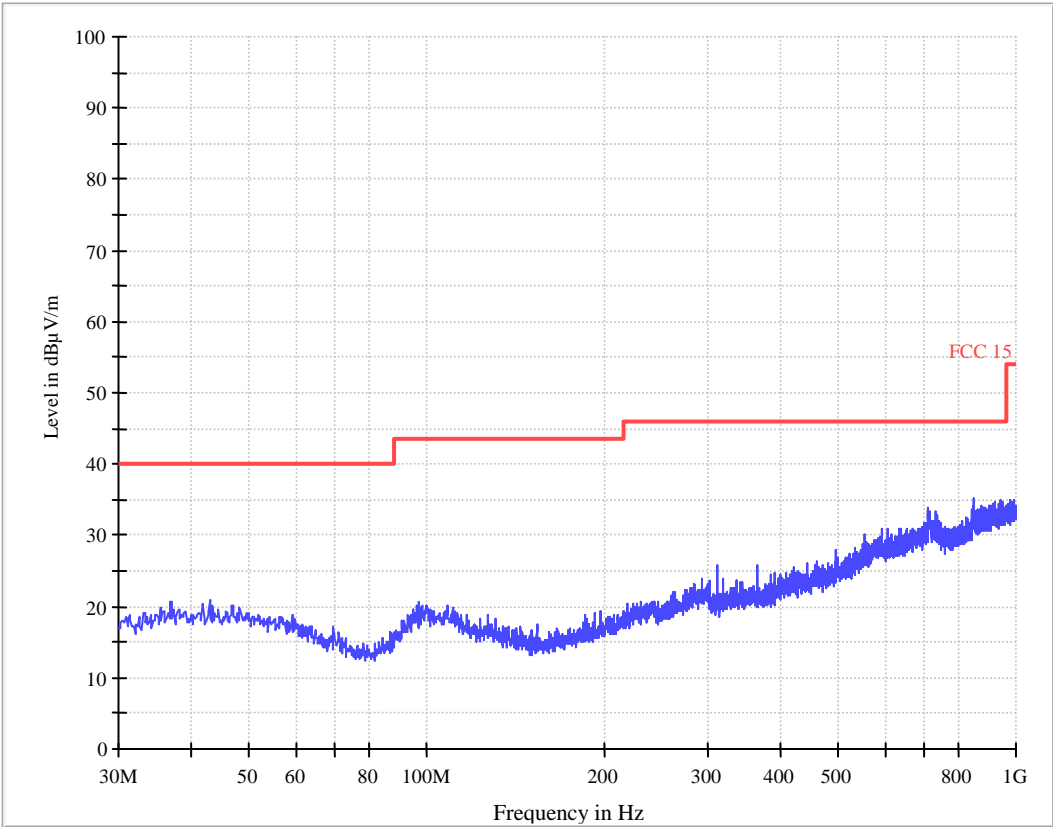

Horizontal:
Level (dB μ V/m)

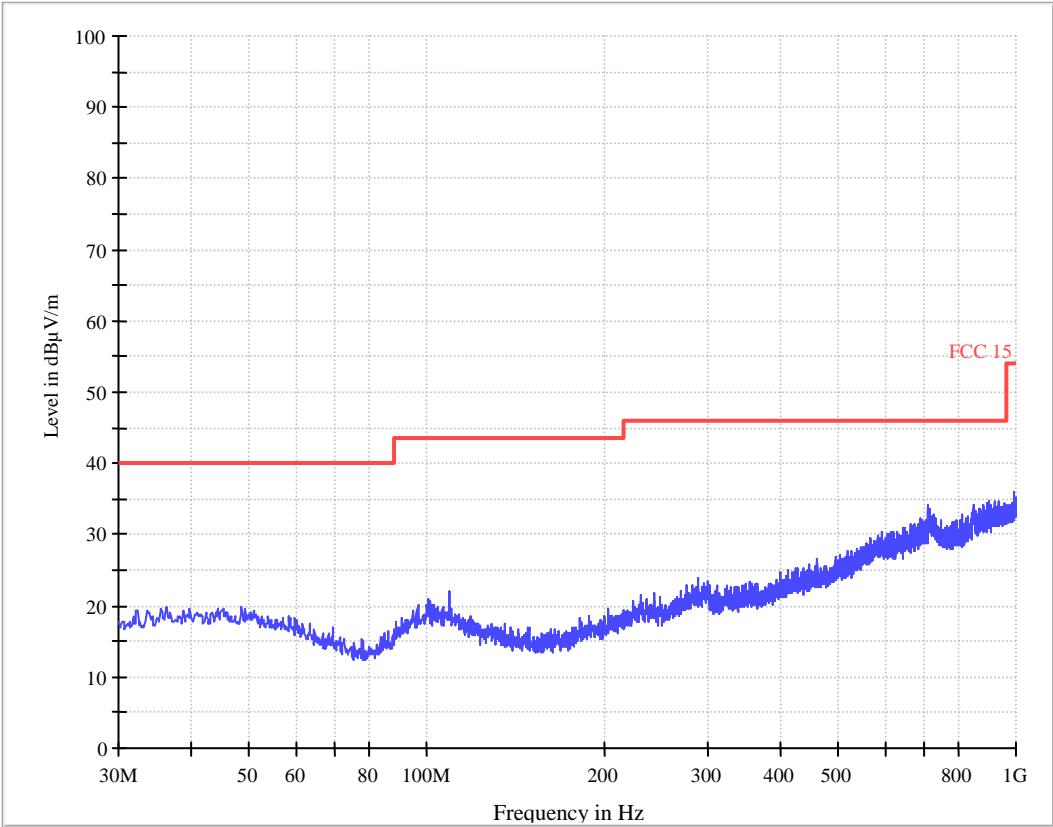



1~25 GHz Radiated Emissions.

PK Measurement:

Frequency (MHz)	PK Reading Level (dB μ V)	Correction factors (dB/m)	PK Emission Level (dB μ V/m)	AV Limit (dB μ V/m)	Antenna polarization
2369.200	45.7	-7.4	38.3	54	V
2488.800	44.8	-7.0	37.8	54	V
2498.000	45.5	-6.9	38.6	54	V
2351.200	49.4	-7.5	41.9	54	H
2484.400	54.8	-7.4	47.4	54	H
2496.000	48.5	-6.9	41.6	54	H

Remark: When Peak emission level was below AV limit, the AV emission level did not be recorded.

Test at Channel 11 (2.462 GHz) in transmitting status

30 MHz~1 GHz Radiated Emissions .Quasi-Peak Measurement

Vertical:

Level (dB μ V/m)

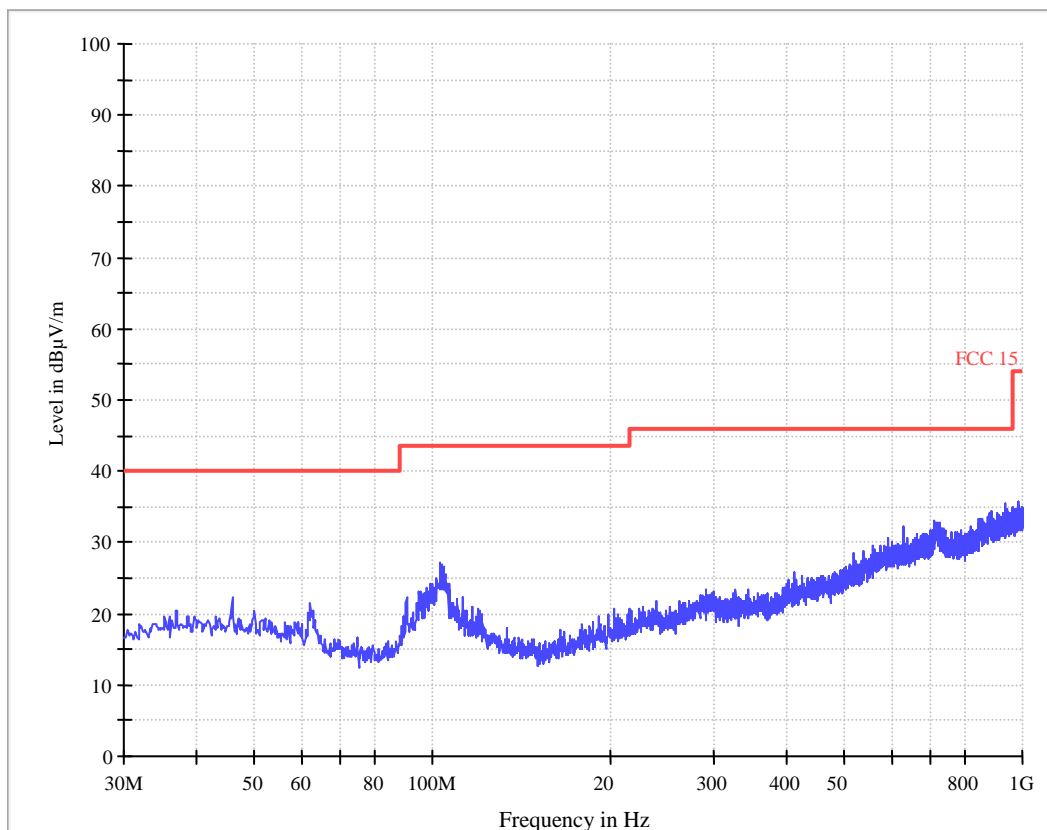

Horizontal:
Level (dB μ V/m)

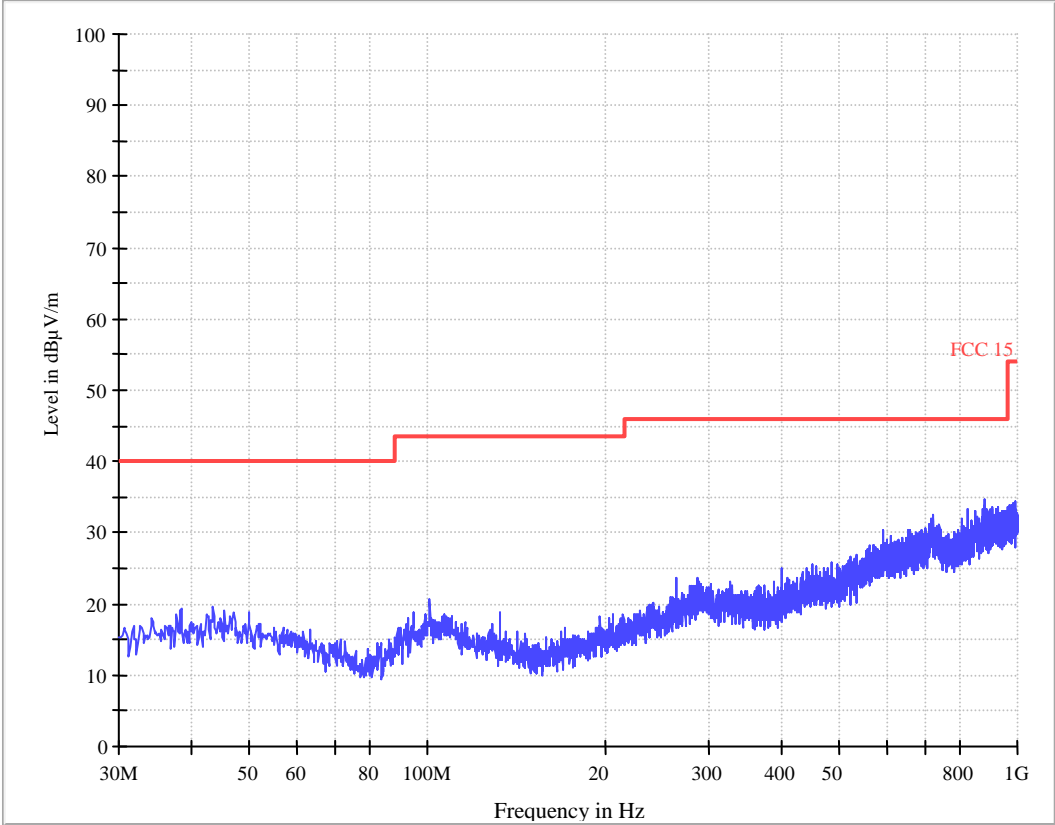



1~25 GHz Radiated Emissions.

PK Measurement:

Frequency (MHz)	PK Reading Level (dB μ V)	Correction factors (dB/m)	PK Emission Level (dB μ V/m)	AV Limit (dB μ V/m)	Antenna polarization
2346.8838	52.787	-7.5	45.287	54	V
2355.3387	53.020	-7.5	45.520	54	V
2366.8575	53.226	-7.4	45.826	54	V
2324.7725	55.127	-7.6	47.527	54	H
2489.9063	54.767	-7.0	47.767	54	H
2493.0413	54.950	-6.9	48.050	54	H

Remark: When Peak emission level was below AV limit, the AV emission level did not be recorded.

The field strength is calculated by adding the Antenna Factor. Cable Factor & Preamplifier. The basic equation with a sample calculation is as follows:

Final Test Level = Receiver Reading + Antenna Factor + Cable Loss – Preamplifier Factor.

As shown in Section, for frequencies above 1000 MHz. the above field strength limits are based on average limits. However, the peak field strength of any emission shall not exceed the maximum permitted average limits specified above by more than 20 dB under any condition of modulation.

No any other emissions level which are attenuated less than 20dB below the limit.

802.11g mode with 54Mbps data rate

9 kHz~30 MHz Field Strength of Unwanted Emissions. Quasi-Peak Measurement

The measurements with active loop antenna were greater than 20dB below the limit, so the test data were not recorded in the test report.

Test at Channel 1 (2.412 GHz) in transmitting status

30 MHz~1 Radiated Emissions .Quasi-Peak Measurement

Vertical:

Level (dB μ V/m)

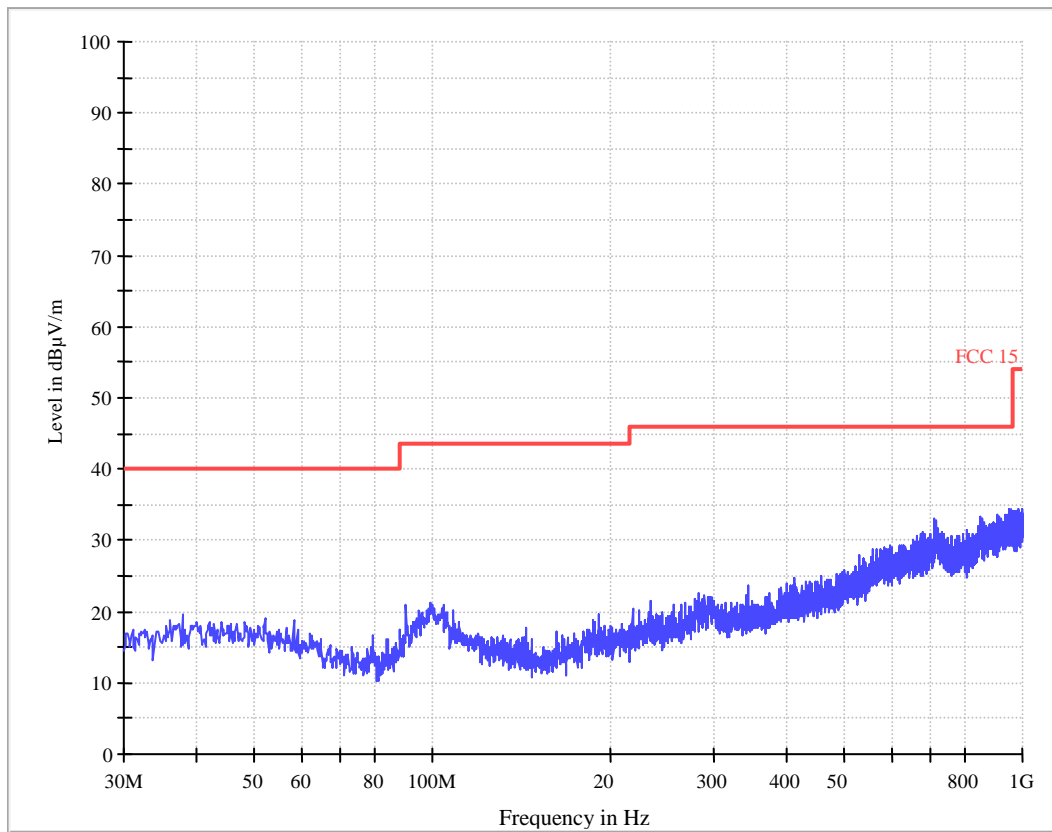

Horizontal:
Level (dB μ V/m)

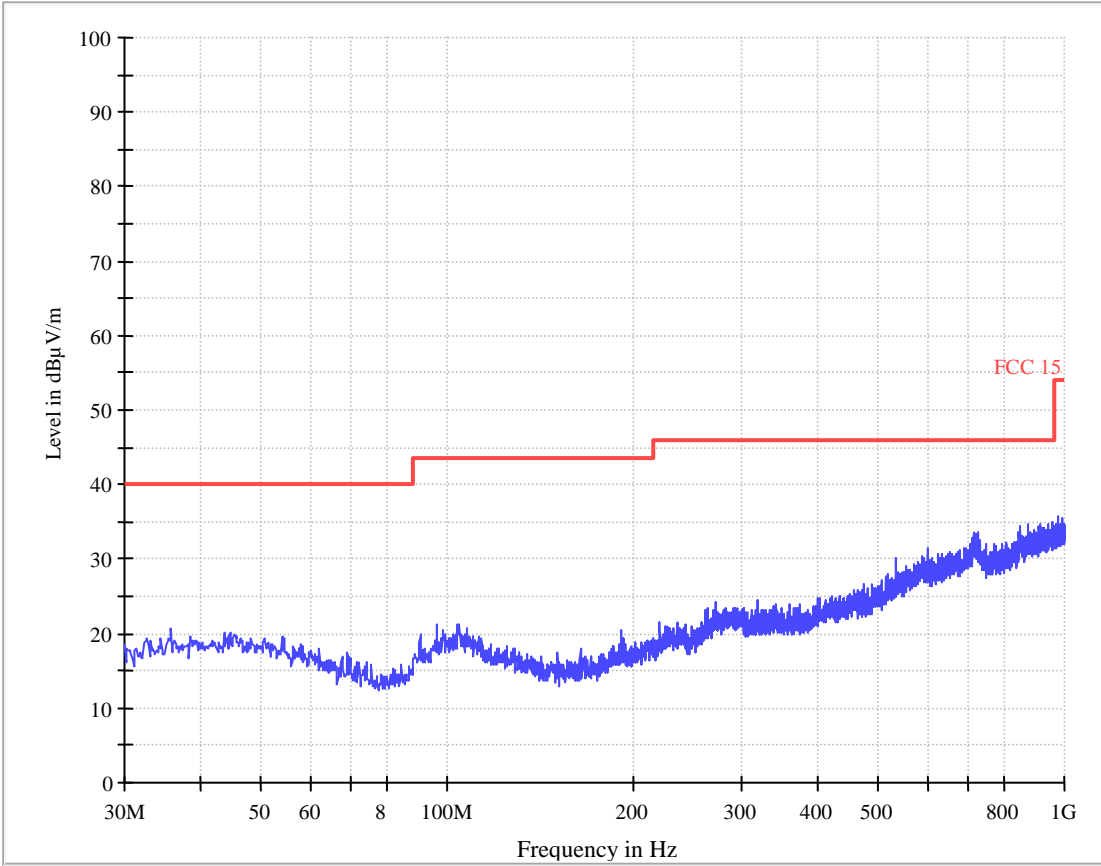



1~25 GHz Radiated Emissions. Peak & Average Measurement

PK Measurement:

Frequency (MHz)	PK Reading Level (dB μ V)	Correction factors (dB/m)	PK Emission Level (dB μ V/m)	AV Limit (dB μ V/m)	Antenna polarization
2343.7963	51.877	-7.5	44.377	54	V
2354.2463	53.313	-7.5	45.813	54	V
2366.2875	53.243	-7.4	45.843	54	V
2489.1938	55.127	-7.0	48.127	54	H
2491.5450	55.401	-7.0	48.401	54	H
2497.0313	54.708	-6.9	47.808	54	H

Remark: When Peak emission level was below AV limit, the AV emission level did not be recorded.

Test at Channel 6 (2.437 GHz) in transmitting status
30 MHz~1 Radiated Emissions .Quasi-Peak Measurement

Vertical:

Level (dB μ V/m)

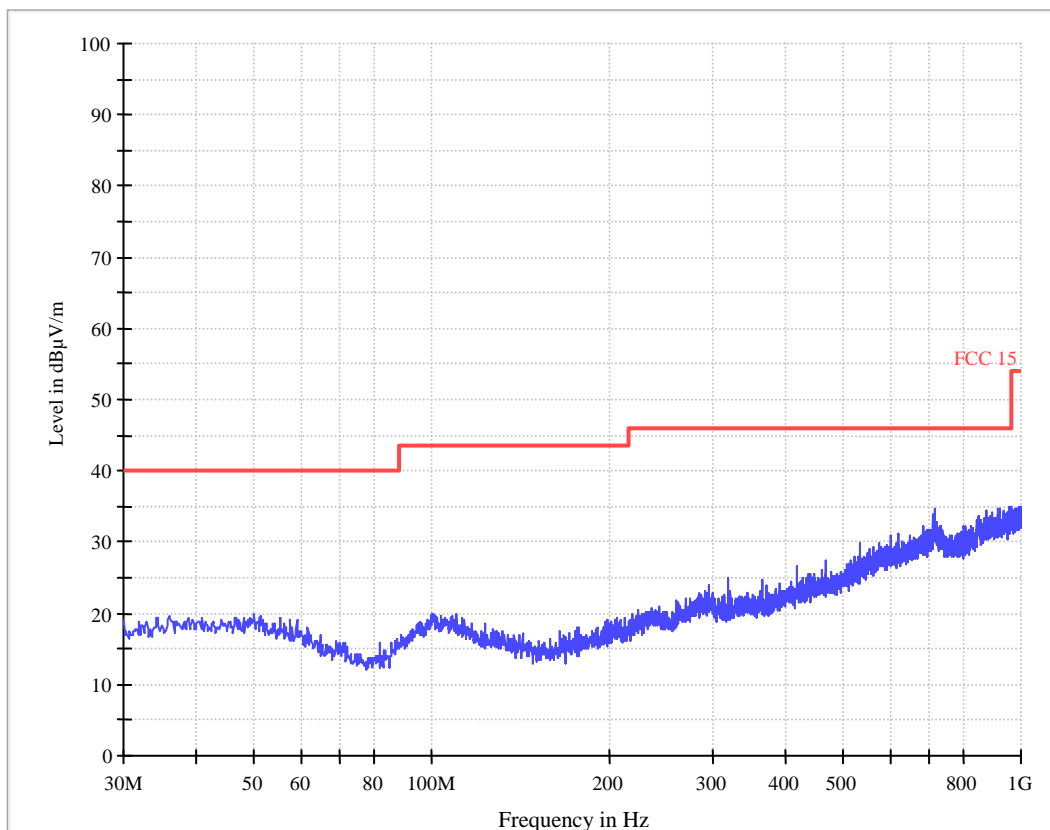

Horizontal:
Level (dB μ V/m)

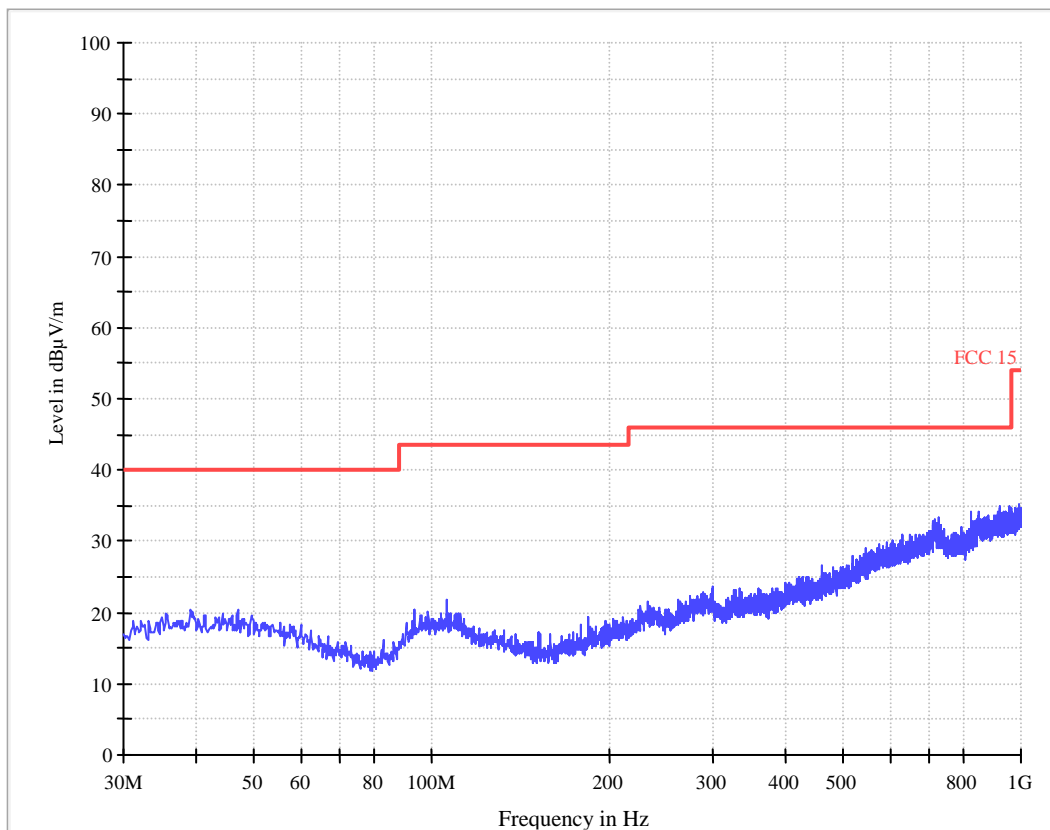



1~25 GHz Radiated Emissions. Peak & Average Measurement

PK Measurement:

Frequency (MHz)	PK Reading Level (dB μ V)	Correction factors (dB/m)	PK Emission Level (dB μ V/m)	AV Limit (dB μ V/m)	Antenna polarization
2382.800	51.9	-7.3	44.6	54	V
2385.600	52.3	-7.3	45.0	54	V
2389.600	56.5	-7.3	49.2	54	V
2348.400	52.1	-7.5	44.6	54	H
2385.200	52.4	-7.3	45.1	54	H
2389.200	57.5	-7.3	50.2	54	H

Remark: When Peak emission level was below AV limit, the AV emission level did not be recorded.

Test at Channel 11 (2.462 GHz) in transmitting status
30 MHz~1 GHz Radiated Emissions .Quasi-Peak Measurement

Vertical:

Level (dB μ V/m)

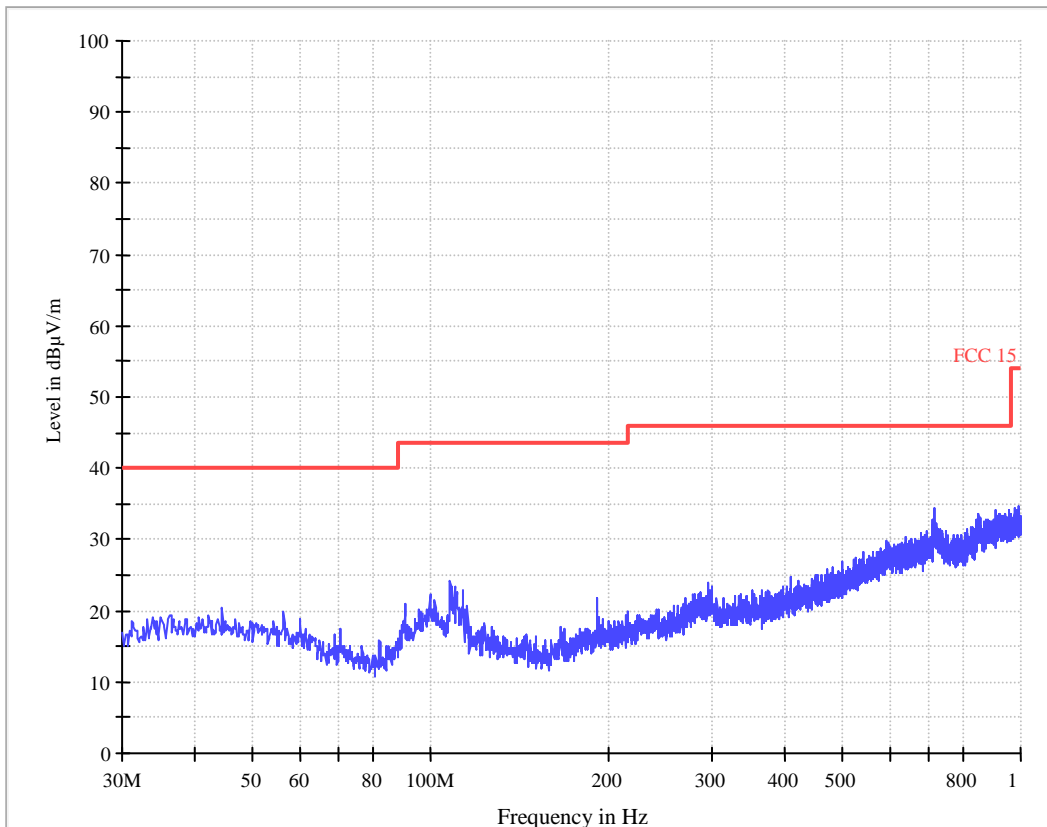

Horizontal:
Level (dB μ V/m)

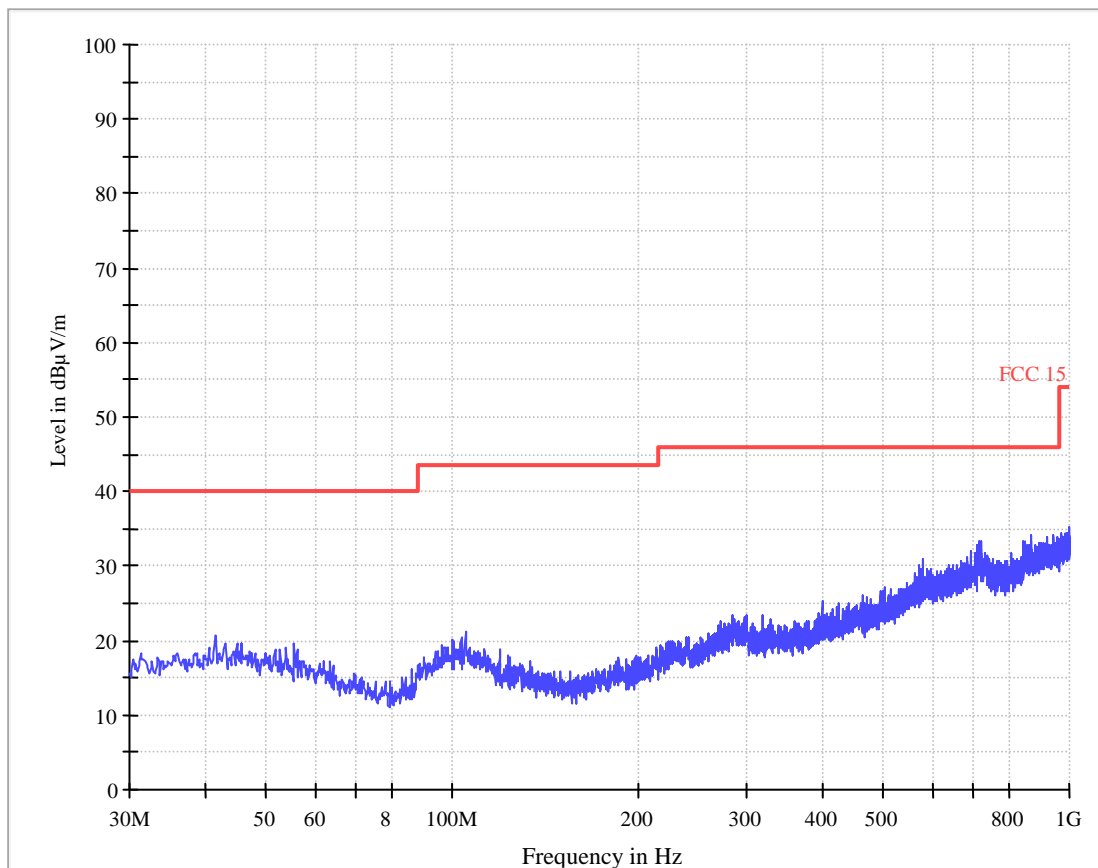



1~25 GHz Radiated Emissions. Peak & Average Measurement

PK Measurement:

Frequency (MHz)	PK Reading Level (dBμV)	Correction factors (dB/m)	PK Emission Level (dBμV/m)	AV Limit (dBμV/m)	Antenna polarization
2483.5413	55.969	-7.4	48.569	54	V
2845.8625	58.356	-7.0	51.356	54	V
2848.2375	55.959	-7.0	48.959	54	V
2483.6363	55.660	-7.0	48.660	54	H
2489.3838	55.519	-7.0	48.519	54	H
2499.0738	54.681	-6.9	47.781	54	H

Remark: When Peak emission level was below AV limit, the AV emission level did not be recorded.

The field strength is calculated by adding the Antenna Factor. Cable Factor & Preamplifier. The basic equation with a sample calculation is as follows:

Final Test Level = Receiver Reading + Antenna Factor + Cable Factor – Preamplifier Factor.

No any other emissions level which are attenuated less than 20dB below the limit.

802.11n (HT20) mode with 72.2Mbps data rate

9 kHz~30 MHz Field Strength of Unwanted Emissions. Quasi-Peak Measurement

The measurements with active loop antenna were greater than 20dB below the limit, so the test data were not recorded in the test report.

Test at Channel 1 (2.412 GHz) in transmitting status

30 MHz~1 GHz Radiated Emissions .Quasi-Peak Measurement

Vertical:

Level (dB μ V/m)

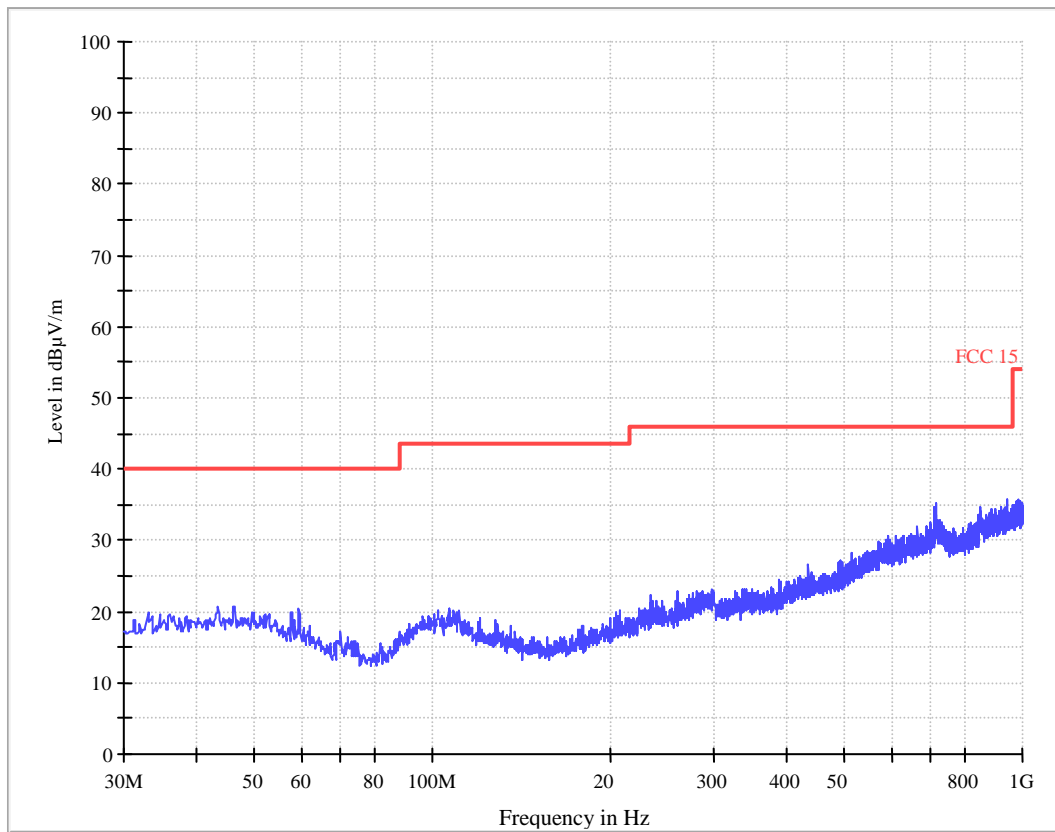

Horizontal:
Level (dB μ V/m)

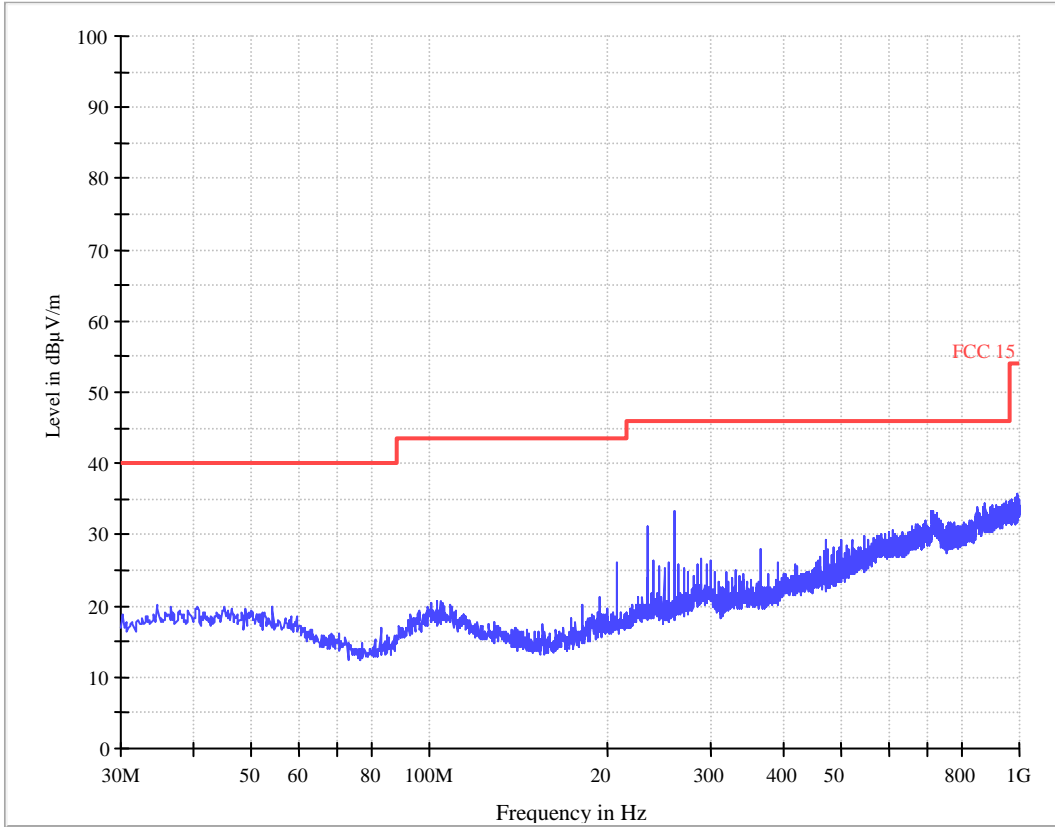



1~25 GHz Radiated Emissions. Peak & Average Measurement

PK Measurement:

Frequency (MHz)	PK Reading Level (dB μ V)	Correction factors (dB/m)	PK Emission Level (dB μ V/m)	AV Limit (dB μ V/m)	Antenna polarization
2331.9925	56.206	-7.5	48.706	54	V
2349.1638	52.276	-7.5	44.776	54	V
2367.7123	53.391	-7.4	45.991	54	V
2484.7763	59.885	-7.0	52.885	54	H
2494.6250	55.366	-6.9	48.466	54	H
2498.8363	60.376	-6.9	53.476	54	H

Remark: When Peak emission level was below AV limit, the AV emission level did not be recorded.

Test at Channel 6 (2.437 GHz) in transmitting status

30 MHz~1 GHz Radiated Emissions .Quasi-Peak Measurement

Vertical:

Level (dB μ V/m)

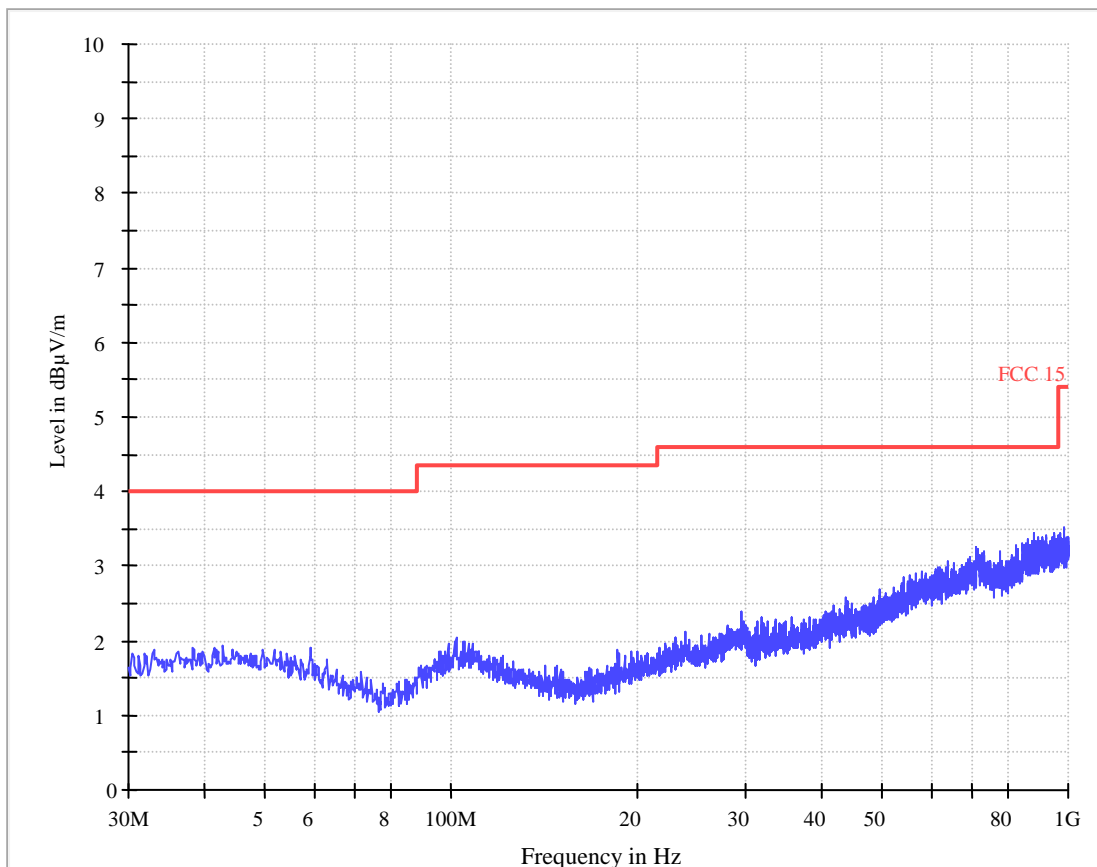

Horizontal:
Level (dB μ V/m)

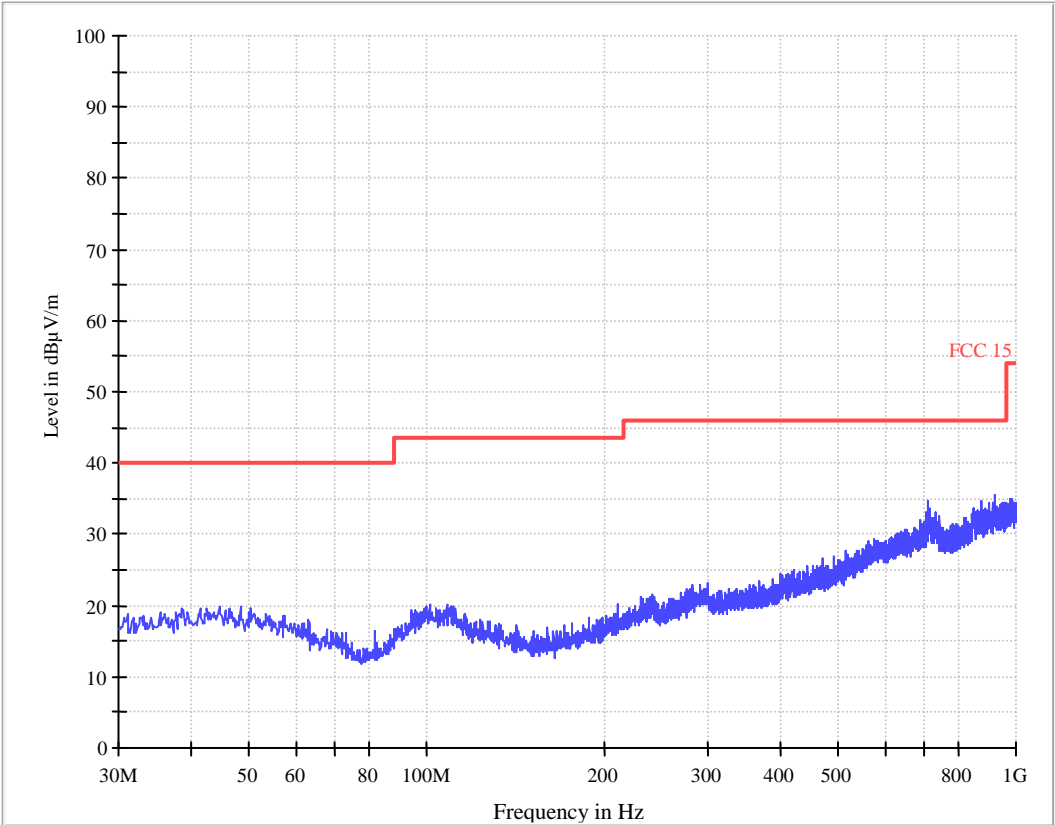



1~25 GHz Radiated Emissions. Peak & Average Measurement

PK Measurement:

Frequency (MHz)	PK Reading Level (dB μ V)	Correction factors (dB/m)	PK Emission Level (dB μ V/m)	AV Limit (dB μ V/m)	Antenna polarization
2374.800	55.2	-7.4	47.8	54	V
2380.800	59.4	-7.4	52.0	54	V
2385.600	59.2	-7.3	51.9	54	V
2371.600	55.4	-7.4	48.0	54	H
2380.000	58.6	-7.4	51.2	54	H
2388.400	59.6	-7.3	52.3	54	H

Remark: When Peak emission level was below AV limit, the AV emission level did not be recorded.

Test at Channel 11 (2.462 GHz) in transmitting status

30 MHz~1 GHz Radiated Emissions .Quasi-Peak Measurement

Vertical:

Level (dB μ V/m)

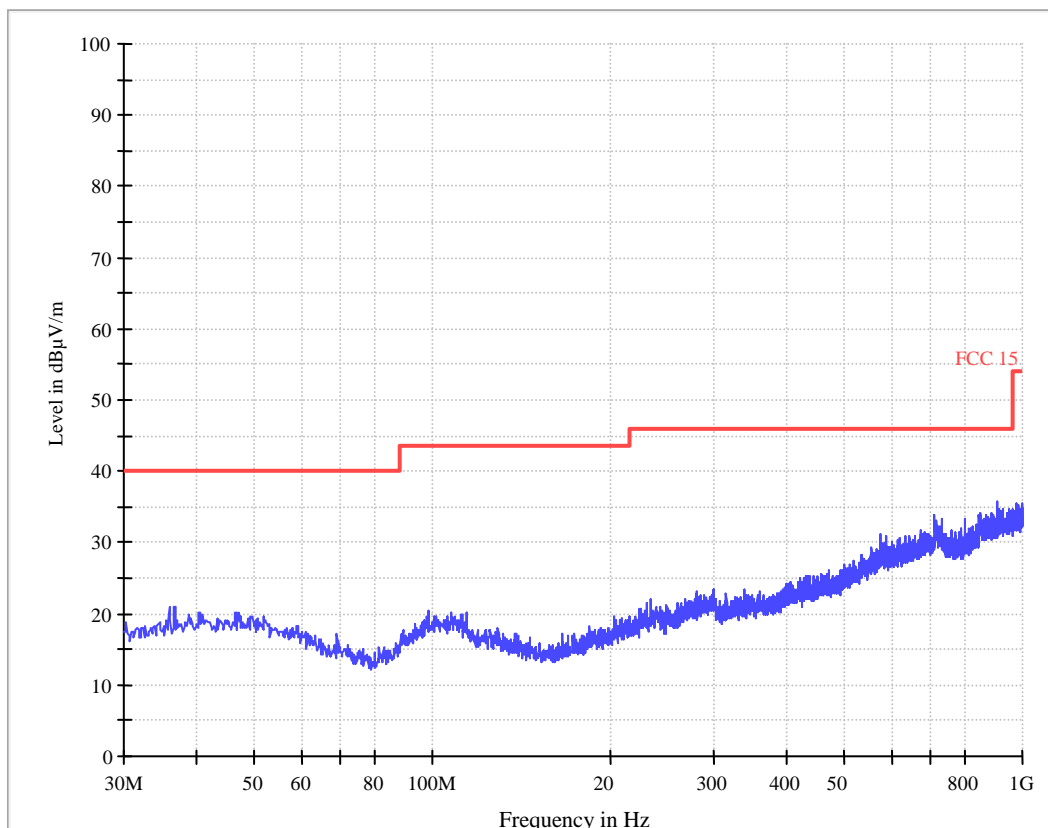

Horizontal:
Level (dB μ V/m)

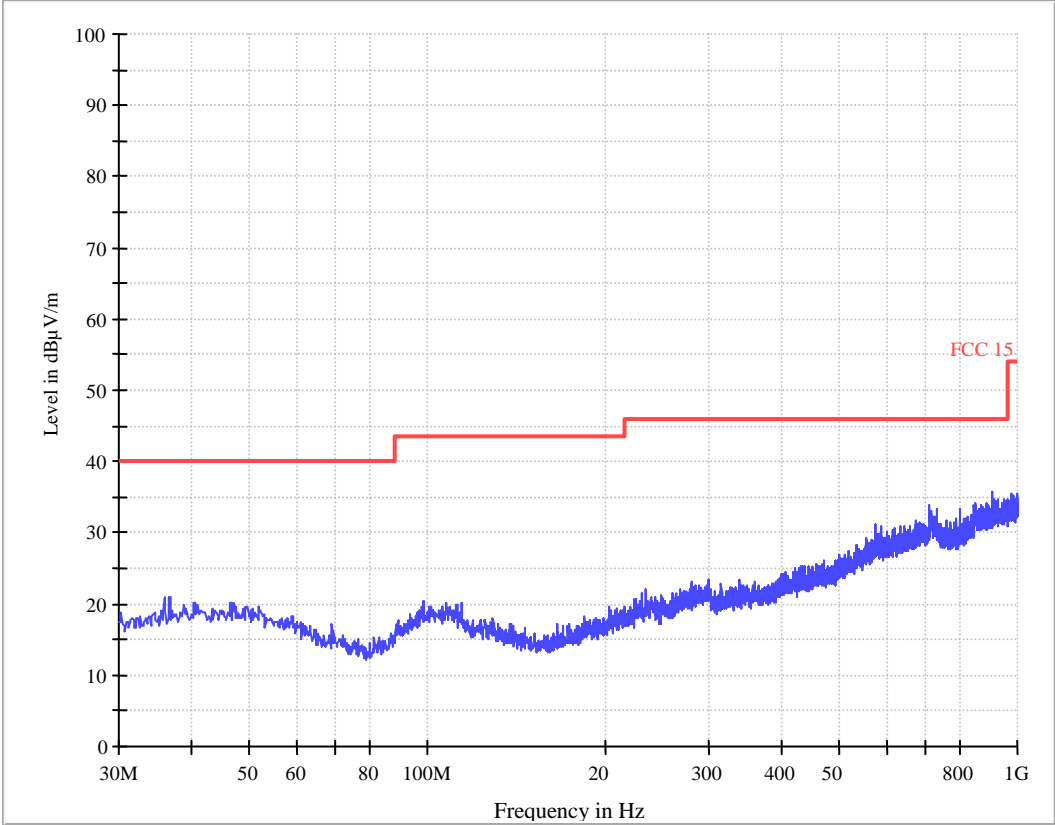



1~25 GHz Radiated Emissions. Peak & Average Measurement

PK Measurement:

Frequency (MHz)	PK Reading Level (dB μ V)	Correction factors (dB/m)	PK Emission Level (dB μ V/m)	AV Limit (dB μ V/m)	Antenna polarization
2362.6538	51.939	-7.4	44.539	54	V
2370.3488	52.084	-7.4	44.684	54	V
2380.0812	56.659	-7.4	49.259	54	V
2381.9863	57.787	-7.4	50.387	54	H
2489.1938	54.920	-7.0	47.920	54	H
2492.4950	55.506	-6.9	48.606	54	H
2495.8438	55.293	-6.9	48.393	54	H

Remark: When Peak emission level was below AV limit, the AV emission level did not be record.

The field strength is calculated by adding the Antenna Factor. Cable Factor & Preamplifier. The basic equation with a sample calculation is as follows:

Final Test Level = Receiver Reading + Antenna Factor + Cable Loss – Preamplifier Factor.

As shown in Section, for frequencies above 1000 MHz. the above field strength limits are based on average limits. However, the peak field strength of any emission shall not exceed the maximum permitted average limits specified above by more than 20 dB under any condition of modulation.

No any other emissions level which are attenuated less than 20dB below the limit.

802.11n (HT40) mode with 150Mbps data rate

9 kHz~30 MHz Field Strength of Unwanted Emissions. Quasi-Peak Measurement

The measurements with active loop antenna were greater than 20dB below the limit, so the test data were not recorded in the test report.

Test at Channel 3 (2.422 GHz) in transmitting status

30 MHz~1 GHz Radiated Emissions .Quasi-Peak Measurement

Vertical:

Level (dB μ V/m)

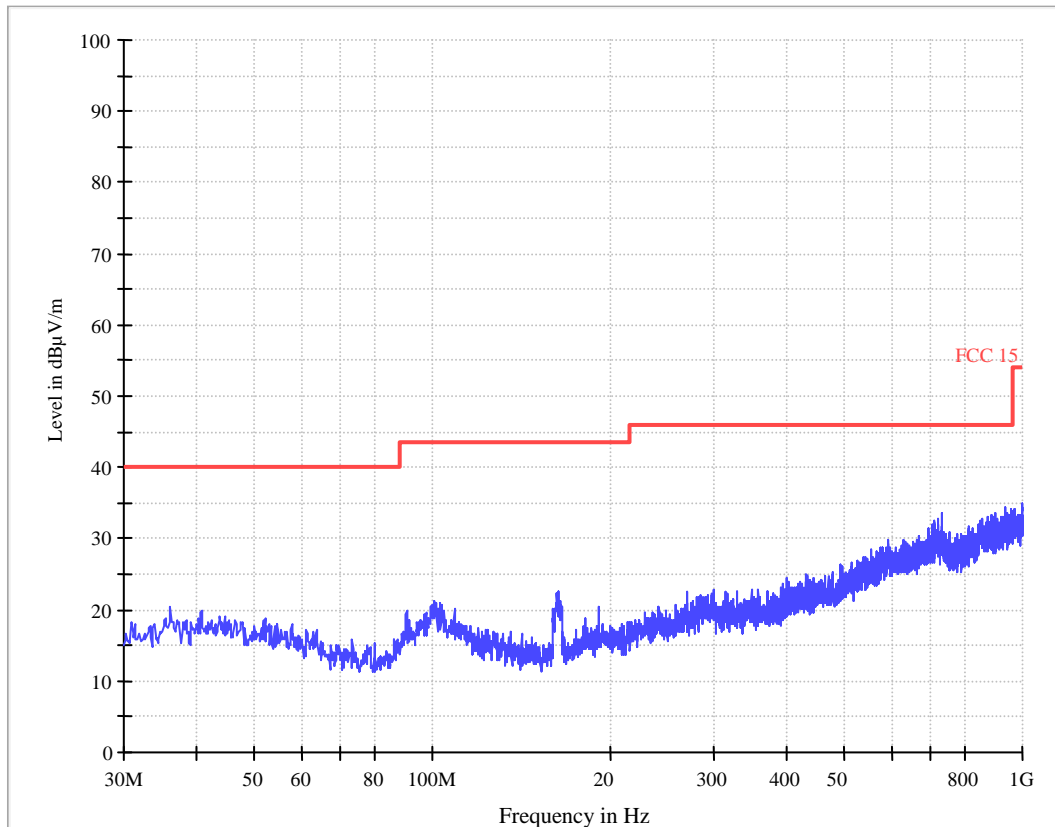

Horizontal:
Level (dB μ V/m)

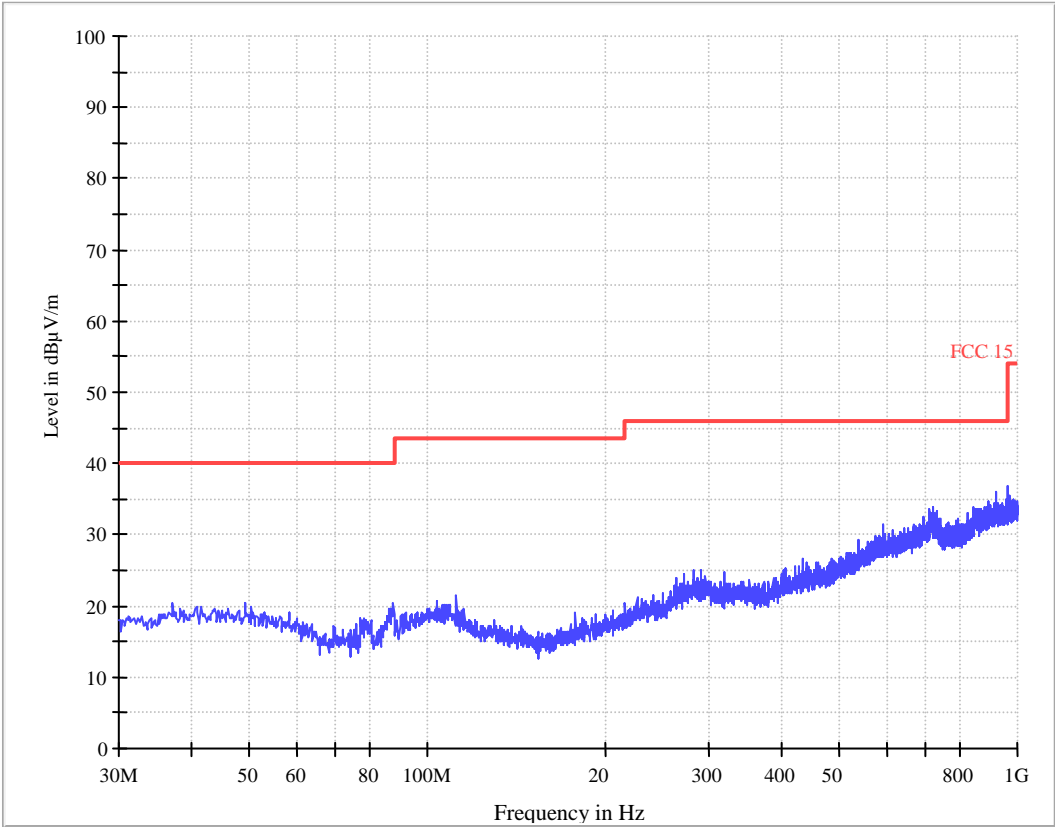



1~25 GHz Radiated Emissions. Peak & Average Measurement

PK Measurement:

Frequency (MHz)	PK Reading Level (dB μ V)	Correction factors (dB/m)	PK Emission Level (dB μ V/m)	AV Limit (dB μ V/m)	Antenna polarization
2342.0388	55.462	-7.5	47.962	54	V
2365.0763	51.975	-7.4	44.575	54	V
2487.1750	56.066	-7.0	49.066	54	V
2342.0625	55.837	-7.5	48.337	54	H
2494.3725	54.303	-6.9	47.403	54	H
2497.6013	54.772	-6.9	47.872	54	H

Remark: When Peak emission level was below AV limit, the AV emission level did not be recorded.

Test at Channel 6 (2.437 GHz) in transmitting status

30 MHz~1 GHz Radiated Emissions .Quasi-Peak Measurement

Vertical:

Level (dB μ V/m)

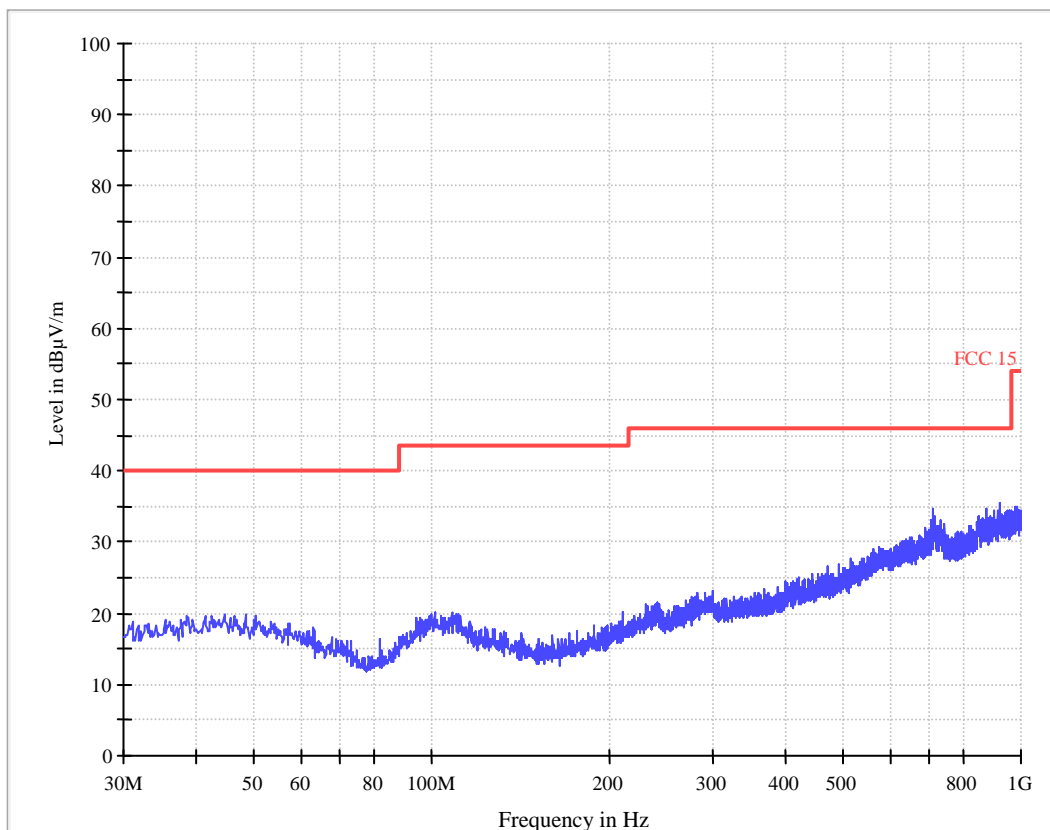

Horizontal:
Level (dB μ V/m)

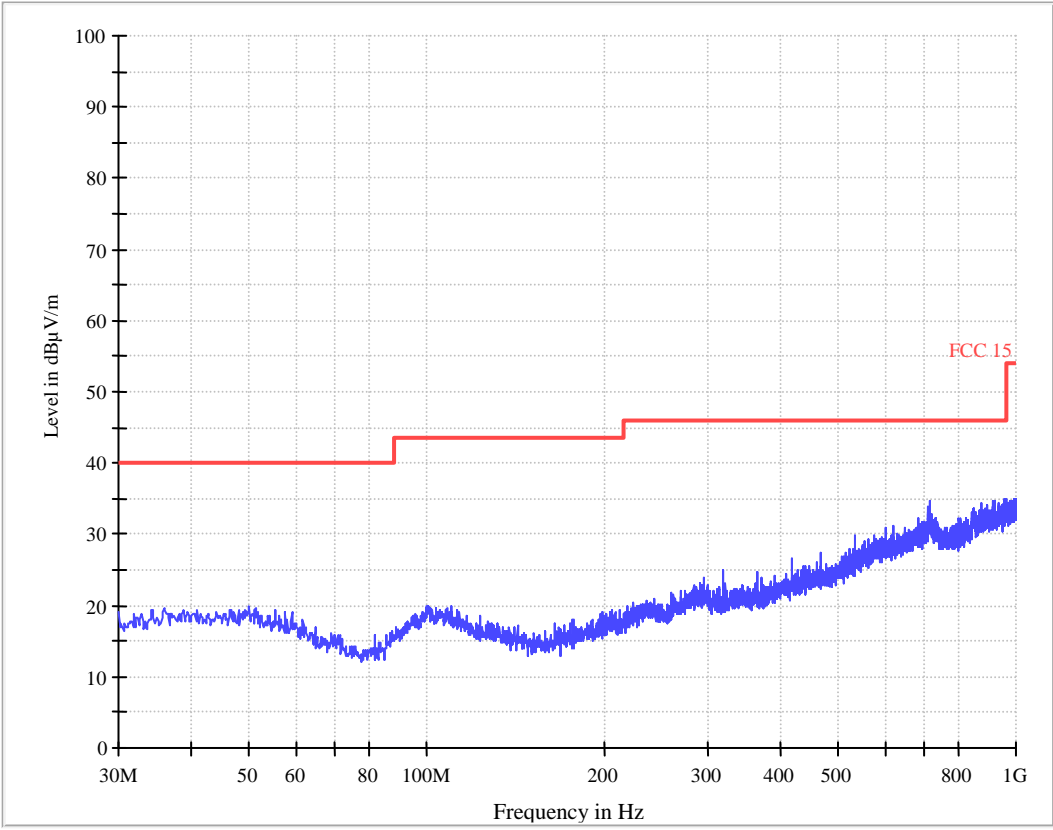



1~25 GHz Radiated Emissions. Peak & Average Measurement

PK Measurement:

Frequency (MHz)	PK Reading Level (dB μ V)	Correction factors (dB/m)	PK Emission Level (dB μ V/m)	AV Limit (dB μ V/m)	Antenna polarization
2382.800	51.6	-7.3	44.3	54	V
2385.600	52.5	-7.3	45.2	54	V
2389.600	56.3	-7.3	49.0	54	V
2348.400	52.3	-7.5	44.8	54	H
2385.200	52.4	-7.3	45.1	54	H
2389.200	57.4	-7.3	50.1	54	H

Remark: When Peak emission level was below AV limit, the AV emission level did not be recorded.

Test at Channel 11 (2.452 GHz) in transmitting status

30 MHz~1 GHz Radiated Emissions .Quasi-Peak Measurement

Vertical:

Level (dB μ V/m)

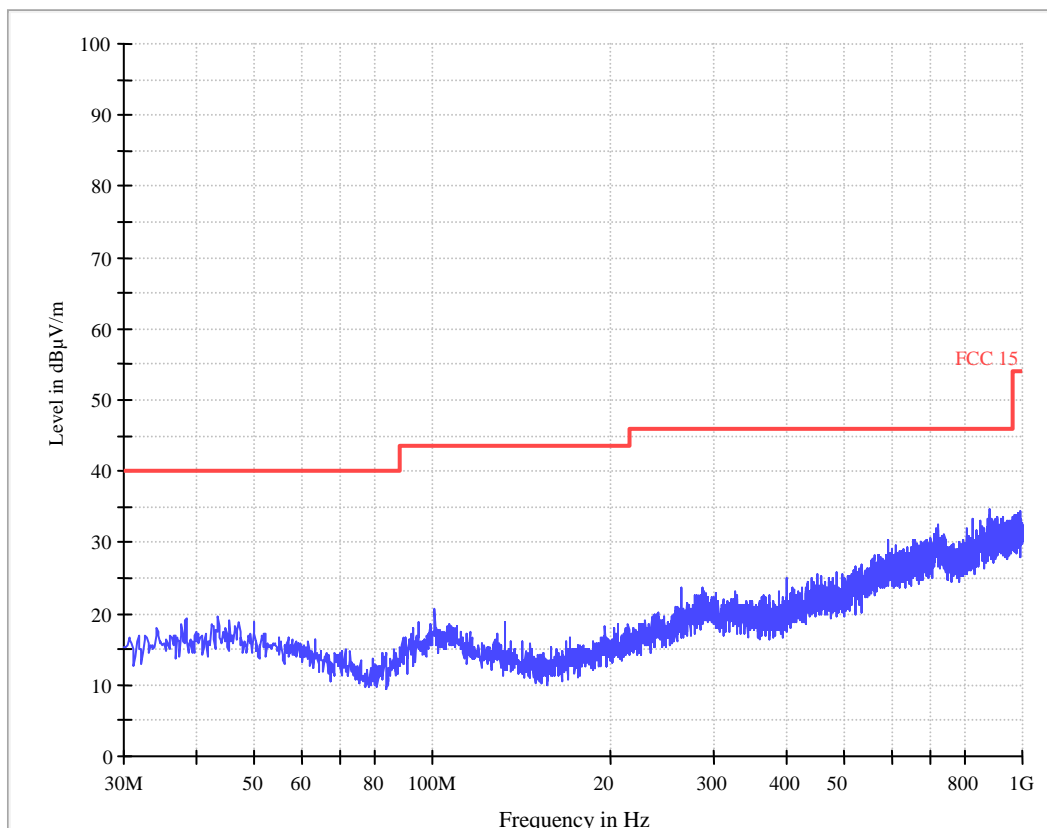

Horizontal:
Level (dB μ V/m)

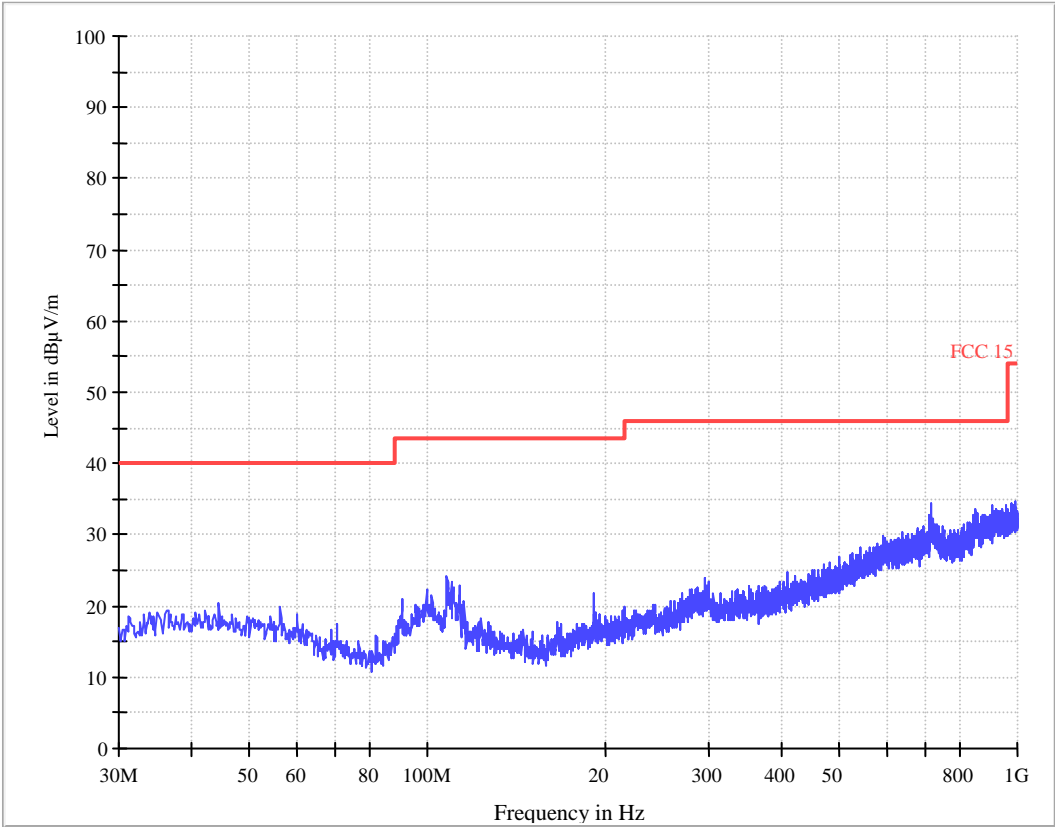



1~25 GHz Radiated Emissions. Peak & Average Measurement

PK Measurement:

Frequency (MHz)	PK Reading Level (dB μ V)	Correction factors (dB/m)	PK Emission Level (dB μ V/m)	AV Limit (dB μ V/m)	Antenna polarization
2342.9888	51.632	-7.5	44.132	54	V
2353.2488	52.904	-7.5	45.404	54	V
2366.0738	52.130	-7.4	44.730	54	V
2350.1613	46.382	-7.5	38.882	54	H
2372.1063	50.165	-7.4	42.765	54	H
2492.1388	45.775	-6.9	38.875	54	H

Remark: When Peak emission level was below AV limit, the AV emission level did not be record.

The field strength is calculated by adding the Antenna Factor. Cable Factor & Preamplifier. The basic equation with a sample calculation is as follows:

Final Test Level = Receiver Reading + Antenna Factor + Cable Loss – Preamplifier Factor.

As shown in Section, for frequencies above 1000 MHz. the above field strength limits are based on average limits. However, the peak field strength of any emission shall not exceed the maximum permitted average limits specified above by more than 20 dB under any condition of modulation.

No any other emissions level which are attenuated less than 20dB below the limit.

4.8 Band Edges Requirement

Test Requirement: FCC Part 15 C section 15.247
RSS-210 A8.5

(d) In any 100 kHz bandwidth outside the frequency band in which the spread spectrum or digitally modulated intentional radiator is operating, the radio frequency power that is produced by the intentional radiator shall be at least 20 dB below that in the 100 kHz bandwidth within the band that contains the highest level of the desired power, based on either an RF conducted or a radiated measurement, provided the transmitter demonstrates compliance with the peak conducted power limits. If the transmitter complies with the conducted power limits based on the use of RMS averaging over a time interval, as permitted under paragraph A8.4 (4), of this section, the attenuation required under this paragraph shall be 30 dB instead of 20 dB. Attenuation below the general limits specified in RSS-Gen table 5 is not required.

Frequency Band: 2400 MHz to 2483.5 MHz

Test Method: ANSI C63.10: Clause 6.9.2 & RSS-Gen clause 4.9

Test Status: Pre-Scan has been conducted to determine the worst-case mode from all possible combinations between available modulations, data rates and antenna ports (if EUT with antenna diversity architecture). Following channel(s) was (were) selected for the final test as listed below.

Test Configuration: For Band Edges Emission in Radiated mode, Please refer to clause 4.7

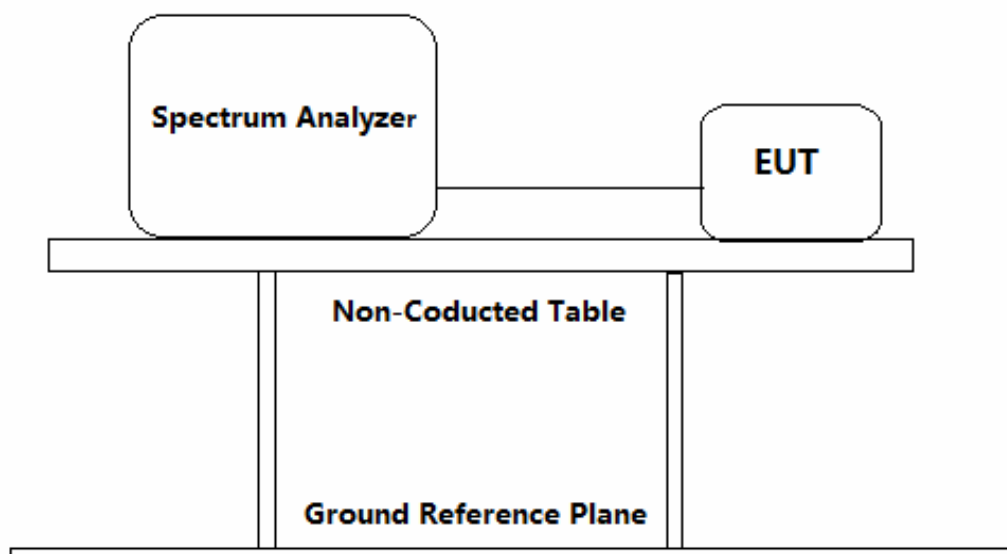

Test Procedure: For Band Edges Emission in Radiated mode, Please refer to clause 4.7

1. Remove the antenna from the EUT and then connect a low RF cable from the antenna port to the spectrum analyzer or power meter.
2. Set RBW of spectrum analyzer to 100 kHz and VBW of spectrum analyzer to 300 kHz with suitable frequency span including 100 kHz bandwidth from band edge (minimum 50 MHz).
3. Repeat until all the test status is investigated.
4. Report the worst case.

Test result with plots as follows:

For conduct mode:

The band edges was measured and recorded Result:

The Lower Edges attenuated more than 20dB.

The Upper Edges attenuated more than 20dB.

Result plots as follows:

802.11b mode with 11 Mbps data rate
Channel1: 2.412 GHz

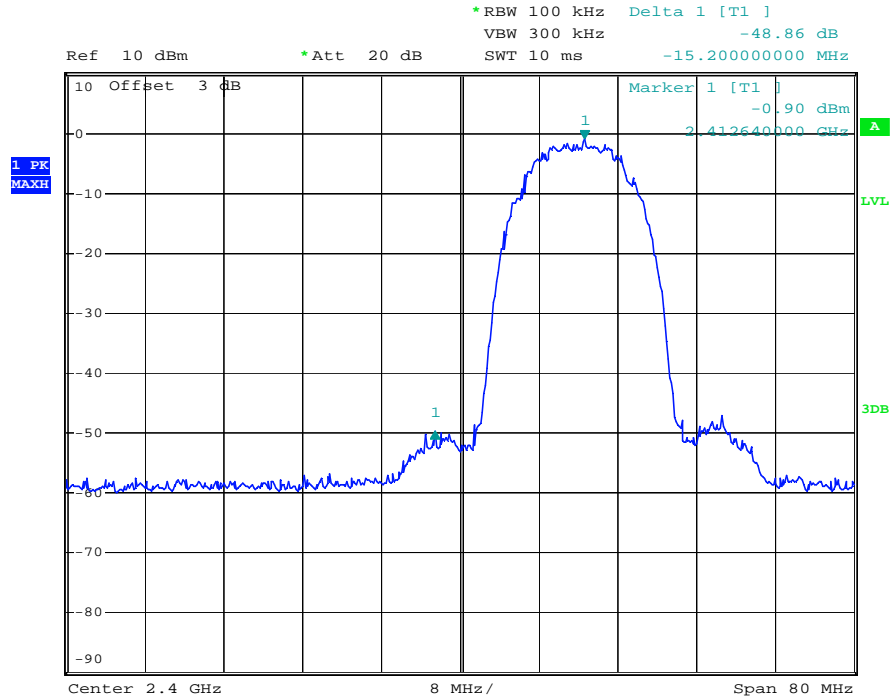

Channel 11: 2.462 GHz

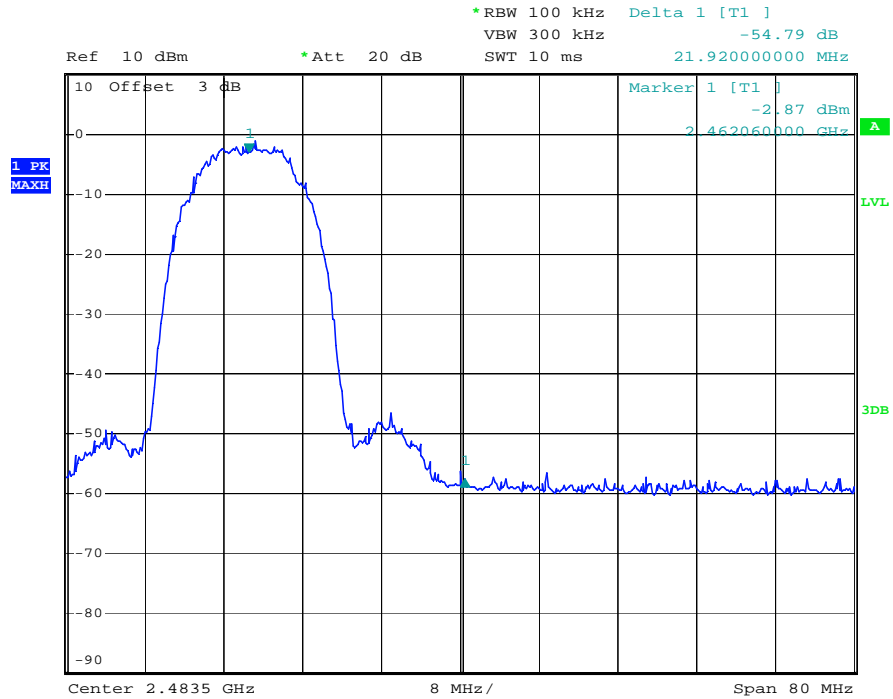

802.11g mode with 54 Mbps data rate
Channel1: 2.412 GHz

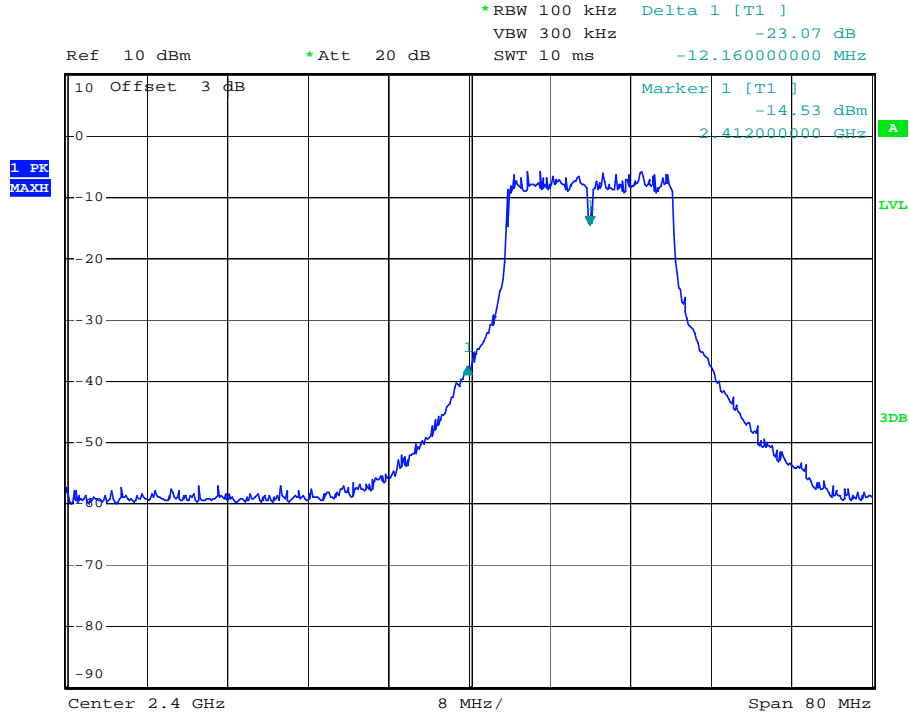

Channel 11: 2.462 GHz

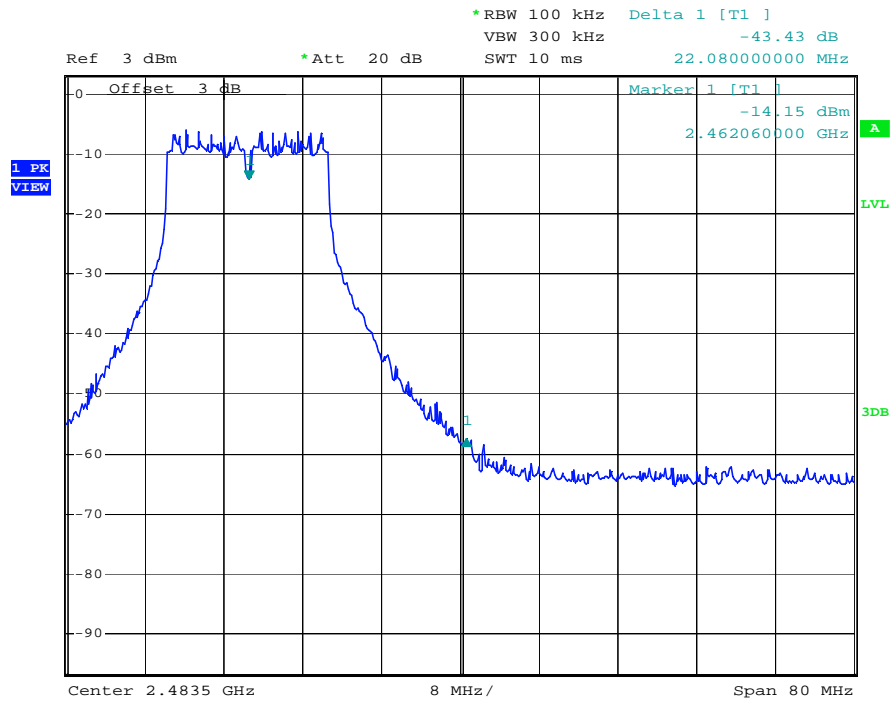

802.11n(HT20) mode with 72.2Mbps data rate
Channel1: 2.412 GHz

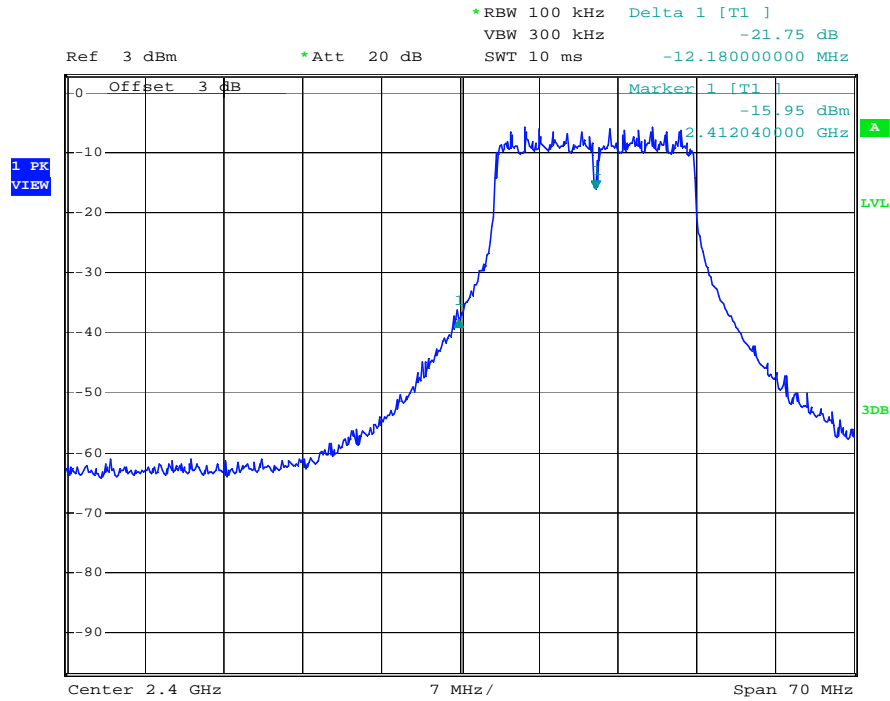

Channel 11: 2.462 GHz

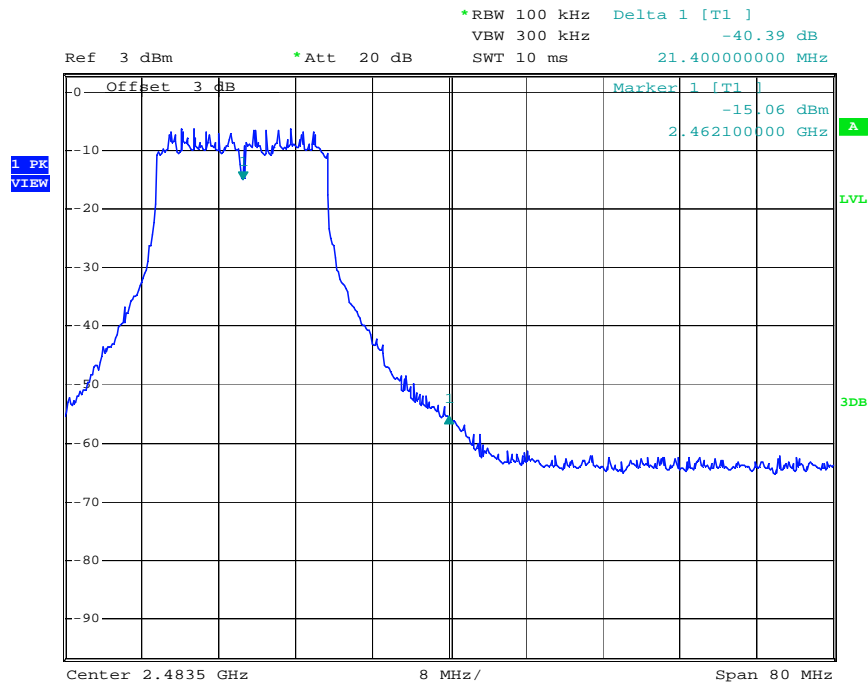

802.11n(HT40) mode with 150Mbps data rate
Channel 3: 2.422 GHz

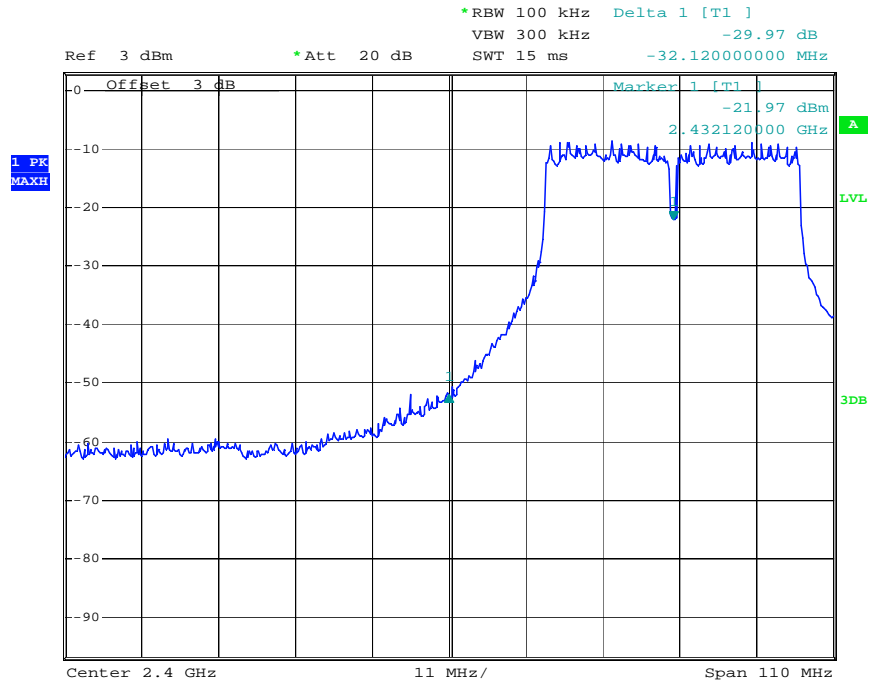

Channel 9: 2.452 GHz

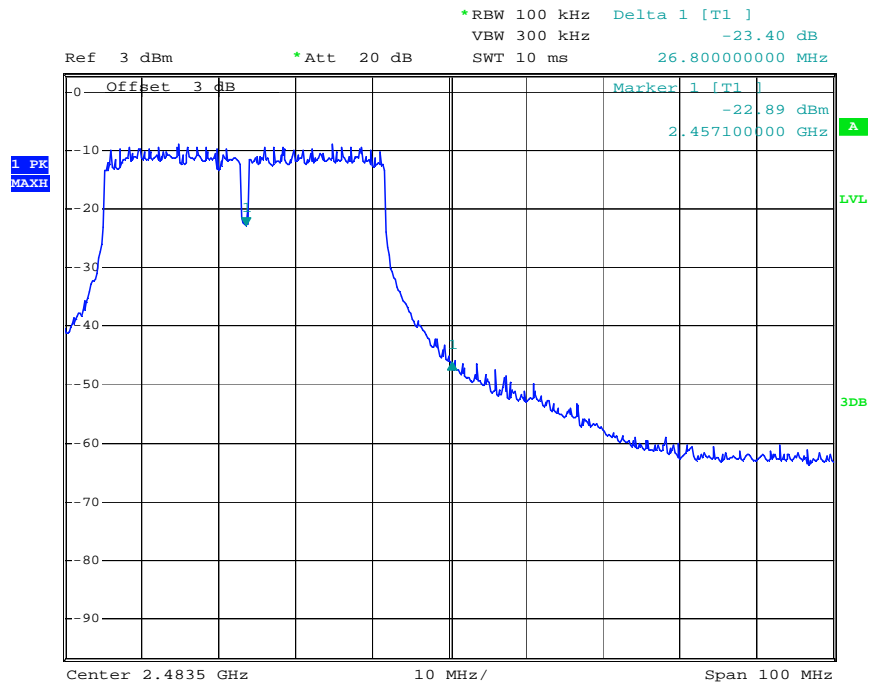

4.9 Conducted Emission Test

Test Configuration:

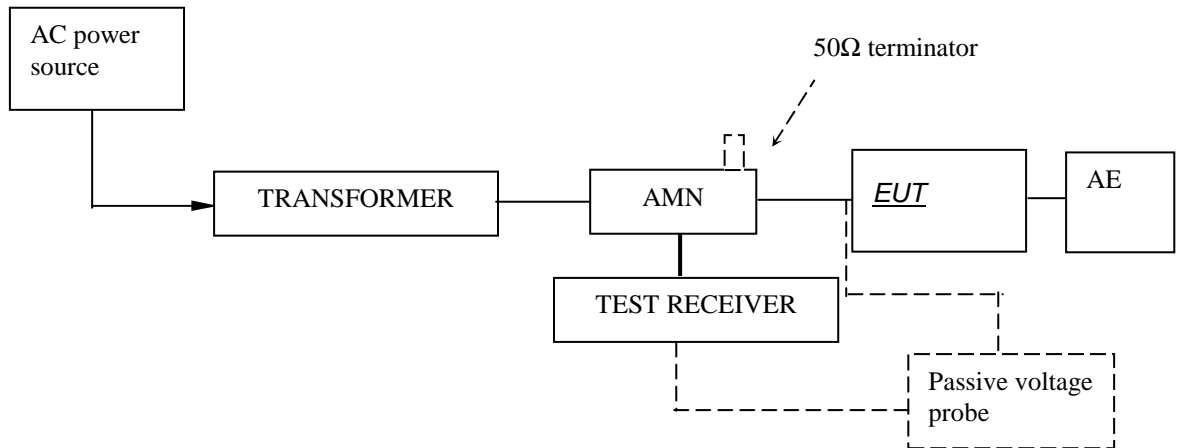

Test Setup and Procedure

Test was performed according to ANSI C63.10 Clause 6.2. The EUT was set to achieve the maximum emission level. The mains terminal disturbance voltage was measured with the EUT in a shielded room. The EUT was connected to AC power source through an Artificial Mains Network which provides a 50Ω linear impedance Artificial hand is used if appropriate (for handheld apparatus). The load/control terminal disturbance voltage was measured with passive voltage probe if appropriate.

The table-top EUT was placed on a 0.8m high non-metallic table above earthed ground plane (Ground Reference Plane). And for floor standing EUT, was placed on a 0.1m high non-metallic supported on GRP. The EUT keeps a distance of at least 0.8m from any other of the metallic surface. The Artificial Mains Network is situated at a distance of 0.8m from the EUT.

During the test, mains lead of EUT excess 0.8m was folded back and forth parallel to the lead so as to form a horizontal bundle with a length between 0.3m and 0.4m.

The bandwidth of test receiver was set at 9 kHz. The frequency range from 150 kHz to 30MHz was checked.

Pre-test in the highest, middle and lowest frequencies with different data rates and modulations, and found the worst case in 802.11b, 11Mbps, 2462MHz, test curve as below:

Test Data

At main terminal: Pass

Tested Wire: Live

Operation Mode: transmitting mode

EDIT PEAK LIST (Final Measurement Results)				
Trace1:	FCC15QP			
Trace2:	FCC15AV			
Trace3:	---			
TRACE	FREQUENCY	LEVEL dBμV		DELTA LIMIT dB
1 Quasi Peak	182 kHz	60.14	L1	-4.24
2 Average	206 kHz	39.25	L1	-14.10
1 Quasi Peak	374 kHz	34.65	L1	-23.75
2 Average	714 kHz	18.66	L1	-27.33
1 Quasi Peak	1.71 MHz	25.47	L1	-30.52
2 Average	4.334 MHz	26.11	L1	-19.88
1 Quasi Peak	4.49 MHz	33.86	L1	-22.13
1 Quasi Peak	7.274 MHz	31.47	L1	-28.53
2 Average	7.302 MHz	24.67	L1	-25.33
1 Quasi Peak	22.822 MHz	41.81	L1	-18.18
2 Average	22.882 MHz	35.88	L1	-14.11

Tested Wire: Neutral

Operation Mode: transmitting mode

EDIT PEAK LIST (Final Measurement Results)				
Trace1:	FCC15QP			
Trace2:	FCC15AV			
Trace3:	---			
TRACE	FREQUENCY	LEVEL dBμV		DELTA LIMIT dB
1 Quasi Peak	198 kHz	58.81	L1	-4.87
2 Average	206 kHz	42.08	L1	-11.27
1 Quasi Peak	390 kHz	33.99	L1	-24.06
2 Average	618 kHz	17.55	L1	-28.44
1 Quasi Peak	1.546 MHz	26.17	L1	-29.82
2 Average	4.266 MHz	24.63	L1	-21.36
1 Quasi Peak	4.43 MHz	33.94	L1	-22.05
1 Quasi Peak	7.478 MHz	28.88	L1	-31.11
2 Average	22.626 MHz	37.56	L1	-12.43
1 Quasi Peak	23.194 MHz	43.14	L1	-16.85

Emission Curve
Tested Wire: Live

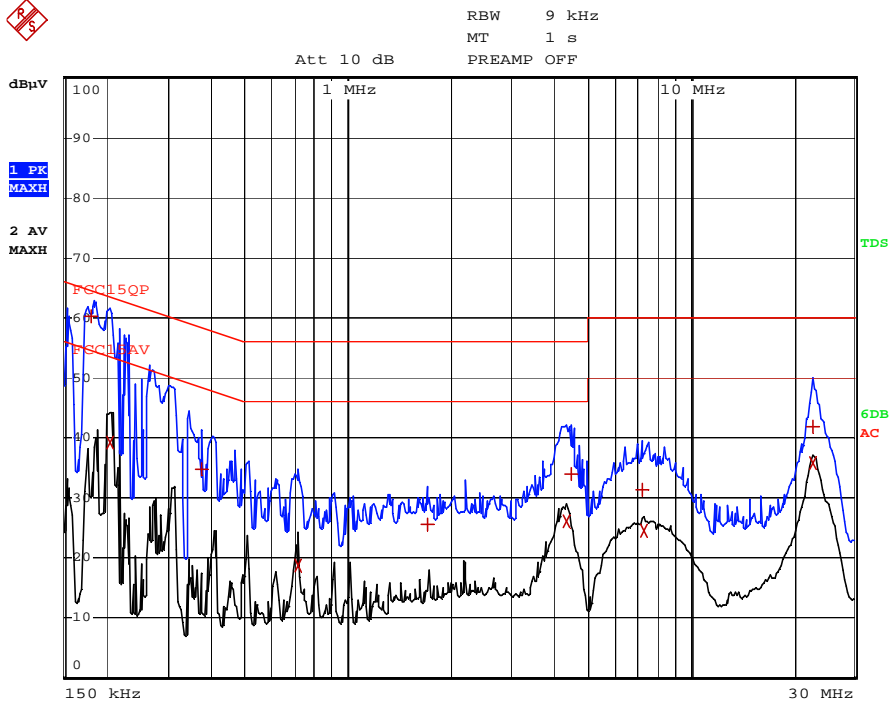

Tested Wire: Neutral

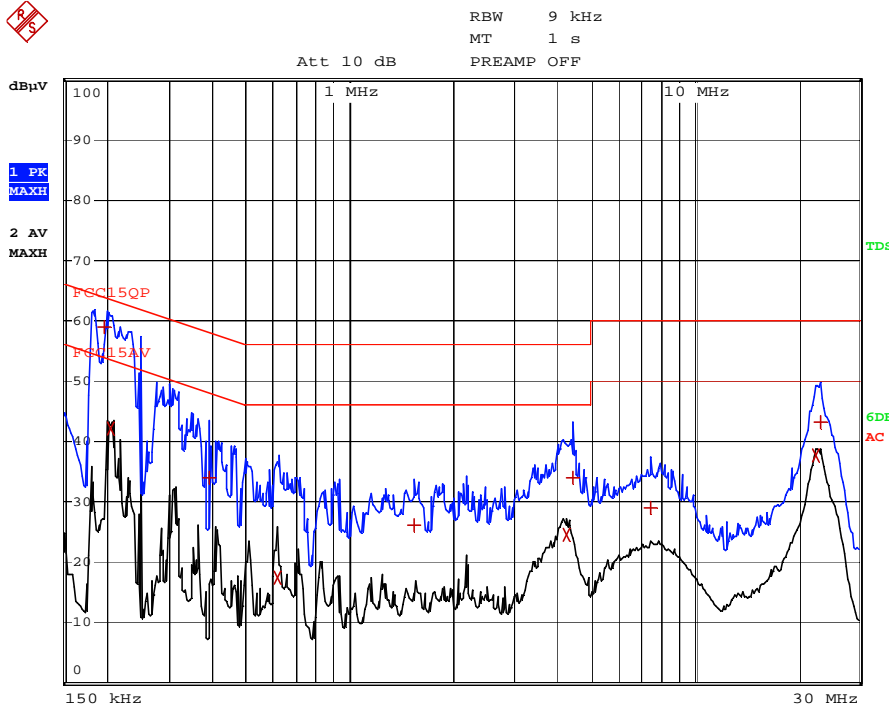

5.0 Test Equipment List

Radiated Emission

Equipment No.	Equipment	Model	Manufacturer	Cal. Due date (YYYY-MM-DD)	Calibration Interval
EM030-01	3m Semi-Anechoic Chamber	9×6×6 m ³	ETS•LINDGREN	2014-04-02	1Y
EM030-02	Control room for 3m Semi-Anechoic Chamber	4×4×3 m ³	ETS•LINDGREN		
EM031-02	EMI Test Receiver (9 kHz~7 GHz)	R&S ESR7	R&S	2014-06-03	1Y
SZ056-03	Spectrum Analyzer	FSP30	R&S	2014-03-10	1Y
EM031-03	Signal and Spectrum Analyzer (10 Hz~40 GHz)	R&S FSV40	R&S	2014-06-03	1Y
EM011-04	Loop antenna (9 kHz-30 MHz)	HFH2-Z2	R&S	2014-05-25	1Y
EM061-03	TRILOG Super Broadband test Antenna (30 MHz-1.5 GHz)	VULB 9161	SCHWARZBECK	2014-05-25	1Y
EM033-02	Bouble-Ridged Waveguide Horn Antenna (800 MHz-18 GHz)	R&S HF907	R&S	2014-05-25	1Y
EM033-03	High Frequency Antenna & preamplifier (18 GHz~26.5 GHz)	R&S SCU-26	R&S	2014-05-25	1Y
EM033-04	High Frequency Antenna & preamplifier (26 GHz-40 GHz)	R&S SCU-40	R&S	2014-05-25	1Y
EM031-02-01	Coaxial cable(9 kHz-1 GHz)	/	R&S	2014-06-03	1Y
EM033-02-02	Coaxial cable(1 GHz-18 GHz)	/	R&S	2014-06-09	
EM033-04-02	Coaxial cable (18~40) GHz	/	R&S	2014-06-09	
EM022-03	2.45 GHz Filter	BRM 50702	Micro-Tronics	2014-05-06	1Y

Conducted emission at the mains terminals test

Equipment No.	Equipment	Model	Manufacturer	Cal.Due date (YYYY-MM-DD)	Calibration Interval
EM080-05	EMI receiver	ESCI	R&S	2014-08-04	1Y
EM006-05	LISN	ENV216	R&S	2014-09-12	1Y
EM006-06	LISN	ENV216	R&S	2014-09-12	1Y
EM006-06-01	Coaxial cable	/	R&S	2014-04-12	1Y
EM004-04	EMC shield Room	8m×3m×3m	Zhongyu	2014-08-04	1Y