

FCC Radio Test Report

Product Name:	Intel Braswell Fanless Mini PC
Trademark:	MINIX
FCC ID:	2ADACNGC-1
Model Name :	NGC-1
Prepared For :	MINIX TECHNOLOGY LIMITED
Address :	Unit 01, 15/F, Chevalier Commercial Center, No.8 Wang Hoi Road, Kowloon Bay, Kowloon, Hong Kong
Prepared By :	DongGuan Precise Testing Service Co., Ltd.
Address :	Building D, Baoding Technology Park, Guangming Road 2, Guangming Community, Dongcheng District, Dongguan, Guangdong, China
Test Date:	Jan. 13 - Feb. 29, 2016
Date of Report :	Feb. 29, 2016
Report No.:	PT800156160119E-FC02

VERIFICATION OF COMPLIANCE

Applicant's name : **MINIX TECHNOLOGY LIMITED**

Address : Unit 01, 15/F, Chevalier Commercial Center, No.8 Wang Hoi Road, Kowloon Bay, Kowloon, Hong Kong

Manufacture's Name : **XIANGUAN ELECTRONICS LIMITED**

Address : 13F., Building B, Haisong Edifice, Tairan 9th Rd., Futian District, Shenzhen, China 518040

Product description

Product name : Intel Braswell Fanless Mini PC

Trademark: MINIX

Model Name: NGC-1

Test procedure FCC Part15.407

Standards ANSI C63.10:2013

This device described above has been tested by PTS, and the test results show that the equipment under test (EUT) is in compliance with the FCC requirements. And it is applicable only to the tested sample identified in the report.

This report shall not be reproduced except in full, without the written approval of PTS, this document may be altered or revised by PTS, personal only, and shall be noted in the revision of the document.

Test Result..... : **Pass**

Testing Engineer :

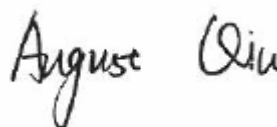

(August Qiu)

Technical Manager :

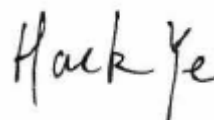

(Hack Ye)

Authorized Signatory :



(Chris Du)

DongGuan Precise Testing Service Co., Ltd.

Building D, Baoding Technology Park, Guangming Road 2, Guangming Community, Dongcheng District, Dongguan, Guangdong, China

Tel: 86-769-23368601

Fax: 86-769-23368602

[http:// www.pts-testing.com](http://www.pts-testing.com)

Table of Contents

	Page
1 . SUMMARY OF TEST RESULTS	5
1.1 TEST FACILITY	6
1.2 MEASUREMENT UNCERTAINTY	6
2 . GENERAL INFORMATION	7
2.1 GENERAL DESCRIPTION OF EUT	7
2.2 DESCRIPTION OF TEST MODES	9
2.3 BLOCK DIGRAM SHOWING THE CONFIGURATION OF SYSTEM TESTED	10
2.4 DESCRIPTION OF SUPPORT UNITS(CONDUCTED MODE)	10
2.5 EQUIPMENTS LIST FOR ALL TEST ITEMS	11
FOR RADIATED EMISSION TEST (BELOW 1GHZ)	11
FOR RADIATED EMISSION TEST (1GHZ ABOVE)	11
3 . EMC EMISSION TEST	13
3.1 CONDUCTED EMISSION MEASUREMENT	13
3.1.1 POWER LINE CONDUCTED EMISSION LIMITS	13
3.1.2 TEST PROCEDURE	14
3.1.3 DEVIATION FROM TEST STANDARD	14
3.1.4 TEST SETUP	14
3.1.5 EUT OPERATING CONDITIONS	14
3.1.6 TEST RESULTS	15
3.2 RADIATED EMISSION MEASUREMENT	19
3.2.1 RADIATED EMISSION LIMITS	19
3.2.2 TEST PROCEDURE	20
3.2.3 DEVIATION FROM TEST STANDARD	20
3.2.4 TEST SETUP	21
3.2.5 EUT OPERATING CONDITIONS	22
3.2.6 TEST RESULTS (BETWEEN 9KHZ – 30 MHZ)	23
3.2.7 TEST RESULTS (BETWEEN 30MHZ – 1GHZ)	24
3.2.8 TEST RESULTS (ABOVE 1000 MHZ)	26
4 . MAXIMUM CONDUCTED OUTPUT POWER	32
4.1 APPLIED PROCEDURES / LIMIT	32
4.2 TEST PROCEDURE	32
4.3 DEVIATION FROM STANDARD	32

DongGuan Precise Testing Service Co., Ltd.

Building D, Baoding Technology Park, Guangming Road 2, Guangming Community, Dongcheng District, Dongguan, Guangdong, China

Tel: 86-769-23368601

Fax: 86-769-23368602

[http:// www.pts-testing.com](http://www.pts-testing.com)

Table of Contents		Page
4.4 TEST SETUP		32
4.5 EUT OPERATION CONDITIONS		32
4.6 TEST RESULTS		33
5 . POWER SPECTRAL DENSITY TEST		34
5.1 APPLIED PROCEDURES / LIMIT		34
5.2 TEST PROCEDURE		34
5.3 DEVIATION FROM STANDARD		34
5.4 TEST SETUP		34
5.5 EUT OPERATION CONDITIONS		34
5.6 TEST RESULTS		35
6 . 99% AND 26DB OCCUPIED BANDWIDTH TEST		41
6.1 APPLIED PROCEDURES / LIMIT		41
6.2 TEST PROCEDURE		41
6.3 DEVIATION FROM STANDARD		41
6.4 TEST SETUP		41
6.5 EUT OPERATION CONDITIONS		41
6.6 TEST RESULTS		42
7 . FREQUENCY STABILITY TEST		48
7.1 APPLICABLE STANDARD		48
7.2 TEST PROCEDURE		48
7.3 DEVIATION FROM STANDARD		48
7.4 TEST SETUP		48
7.5 EUT OPERATION CONDITIONS		48
7.6 TEST RESULT FOR CONDUCTED SPURIOUS EMISSIONS TEST		49
8 . ANTENNA REQUIREMENT		53
8.1 STANDARD REQUIREMENT		53
8.2 EUT ANTENNA		53
9 . EUT TEST PHOTO		54

DongGuan Precise Testing Service Co., Ltd.

Building D, Baoding Technology Park, Guangming Road 2, Guangming Community, Dongcheng District, Dongguan, Guangdong, China

Tel: 86-769-23368601

Fax: 86-769-23368602

[http:// www.pts-testing.com](http://www.pts-testing.com)

1. SUMMARY OF TEST RESULTS

Test procedures according to the technical standards:

FCC Part15 (15.407) , Subpart E			
Standard Section	Test Item	Judgment	Remark
§15.407(a)	Maximum Conducted Output Power	PASS	
§15.407(a)	Power Spectral Density	PASS	
§15.407(a)	26dB Bandwidth	PASS	
§15.407(a)	99% Occupied Bandwidth	PASS	
§15.407(b)	Radiated Emissions	PASS	
§15.407(b)	Band edge Emissions	PASS	
§15.205	Emissions at Restricted Band	PASS	
§15.407(g)	Frequency Stability	PASS	
§15.207(a)	Line Conducted Emissions	PASS	
§15.203	Antenna Requirements	PASS	
§2.1093	RF Exposure	PASS	

NOTE:

(1) "N/A" denotes test is not applicable in this Test Report

(2) For MIMO the directional gain = $G_{ANT} + 10 \log(N_{ANT})$ dBi according to KDB 662911 v02r01, so for this product the directional gain is 8.01dBi.

DongGuan Precise Testing Service Co., Ltd.

Building D, Baoding Technology Park, Guangming Road 2, Guangming Community, Dongcheng District, Dongguan, Guangdong, China

Tel: 86-769-23368601

Fax: 86-769-23368602

[http:// www.pts-testing.com](http://www.pts-testing.com)

1.1 TEST FACILITY

FCC Registration No.: 371540, IC Registration No.: 12191A-1

Dongguan Precise Testing Service Co., Ltd.

Add.: Building D, Baoding Technology Park, Guangming Road 2, Dongcheng District, Dongguan, Guangdong, China

1.2 MEASUREMENT UNCERTAINTY

The reported uncertainty of measurement $y \pm U$, where expanded uncertainty U is based on a standard uncertainty multiplied by a coverage factor of $k=2$, providing a level of confidence of approximately **95 %**.

No.	Item	Uncertainty
1	Conducted Emission Test	$\pm 1.38\text{dB}$
2	RF power, conducted	$\pm 0.16\text{dB}$
3	Spurious emissions, conducted	$\pm 0.21\text{dB}$
4	All emissions, radiated (<1G)	$\pm 4.68\text{dB}$
5	All emissions, radiated (>1G)	$\pm 4.89\text{dB}$
6	Temperature	$\pm 0.5^\circ\text{C}$
7	Humidity	$\pm 2\%$

DongGuan Precise Testing Service Co., Ltd.

Building D, Baoding Technology Park, Guangming Road 2, Guangming Community, Dongcheng District, Dongguan, Guangdong, China

Tel: 86-769-23368601

Fax: 86-769-23368602

[http:// www.pts-testing.com](http://www.pts-testing.com)

2. GENERAL INFORMATION

2.1 GENERAL DESCRIPTION OF EUT

Equipment	Intel Braswell Fanless Mini PC	
Trade Name	MINIX	
Model Name	NGC-1	
Product Description	The EUT is a Wireless USB Adapter	
	Operation Frequency:	5150~5250MHz
	Modulation Type:	802.11n: OFDM (64QAM, 16QAM,QPSK,BPSK) 802.11a: OFDM (64QAM, 16QAM,QPSK,BPSK) 802.11ac: OFDM (64QAM, 16QAM,QPSK,BPSK)
	Bit Rate of Transmitter:	802.11n-HT20: 6.5-65 Mbps 802.11n-HT40:13.5-135 Mbps 802.11a: 6-54Mbps 802.11ac: MCS0~MCS9
	Number Of Channel:	For 20MHz bandwidth: 4 Channels For 40MHz bandwidth: 2 Channels For 80MHz bandwidth: 1 Channels
	Antenna Designation:	Please see Note 3.
	Antenna Gain (dBi)	5.0dBi; For MIMO the antenna gain is 8.01dBi
	Based on the application, features, or specification exhibited in User's Manual, the EUT is considered as an ITE/Computing Device. More details of EUT technical specification, please refer to the User's Manual.	
Channel List:	Please refer to the Note 2.	
Power supply:	DC 12.0V	
Connecting I/O Port(s)	Please refer to the User's Manual	

Note:

DongGuan Precise Testing Service Co., Ltd.

Building D, Baoding Technology Park, Guangming Road 2, Guangming Community, Dongcheng District, Dongguan, Guangdong, China

Tel: 86-769-23368601

Fax: 86-769-23368602

http:// www.pts-testing.com

1. For a more detailed features description, please refer to the manufacturer's specifications or the User's Manual.

2.

Channel List for 802.11n(HT20)/802.11a/802.11ac(20MHz)							
Channel	Frequency (MHz)	Channel	Frequency (MHz)	Channel	Frequency (MHz)	Channel	Frequency (MHz)
36	5180	40	5200	44	5200	48	5240

Channel List for 802.11n(HT40)/802.11ac(40MHz)							
Channel	Frequency (MHz)	Channel	Frequency (MHz)	Channel	Frequency (MHz)	Channel	Frequency (MHz)
38	5190	46	5230	--	--	--	--

Channel List for /802.11ac(80MHz)							
Channel	Frequency (MHz)	Channel	Frequency (MHz)	Channel	Frequency (MHz)	Channel	Frequency (MHz)
42	5210	--	--	--	--	--	--

3.

Table for Filed Antenna

Ant.	Brand	Model Name	Antenna Type	Connector	Gain (dBi)	NOTE
A	N/A	N/A	Detachable Antenna	R-SMA	5.0	WIFI Antenna

2.2 DESCRIPTION OF TEST MODES

To investigate the maximum EMI emission characteristics generates from EUT, the test system was pre-scanning tested base on the consideration of following EUT operation mode or test configuration mode which possible have effect on EMI emission level. Each of these EUT operation mode(s) or test configuration mode(s) mentioned above was evaluated respectively.

Pretest Mode	Description
Mode 1	802.11n-HT20 CH36/ CH40/ CH48
Mode 2	802.11-HT40 CH38/ CH46
Mode 3	802.11a CH36/ CH40/ CH48
Mode 4	802.11ac(20MHz) CH36/ CH40/ CH48
Mode 5	802.11ac(40MHz) CH38/ CH46
Mode 6	802.11ac(80MHz) CH42
Mode 7	Link Mode

For Conducted Emission	
Final Test Mode	Description
Mode 7	Link Mode

For Radiated Emission	
Final Test Mode	Description
Mode 1	802.11n-HT20 CH36/ CH40/ CH48
Mode 2	802.11-HT40 CH38/ CH46
Mode 3	802.11a CH36/ CH40/ CH48
Mode 4	802.11ac(20MHz) CH36/ CH40/ CH48
Mode 5	802.11ac(40MHz) CH38/ CH46
Mode 6	802.11ac(80MHz) CH42
Mode 7	Link Mode

Note:

- (1) The measurements are performed at the highest, middle, lowest available channels.
- (2) The measurements are performed at all Bit Rate of Transmitter, the worst data was reported

DongGuan Precise Testing Service Co., Ltd.

Building D, Baoding Technology Park, Guangming Road 2, Guangming Community, Dongcheng District, Dongguan, Guangdong, China

Tel: 86-769-23368601

Fax: 86-769-23368602

[http:// www.pts-testing.com](http://www.pts-testing.com)

2.3 BLOCK DIGRAM SHOWING THE CONFIGURATION OF SYSTEM TESTED

Conducted Emission Test

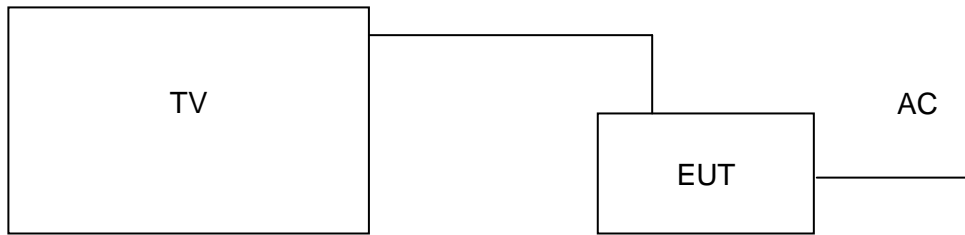

Radiated Spurious Emission Test

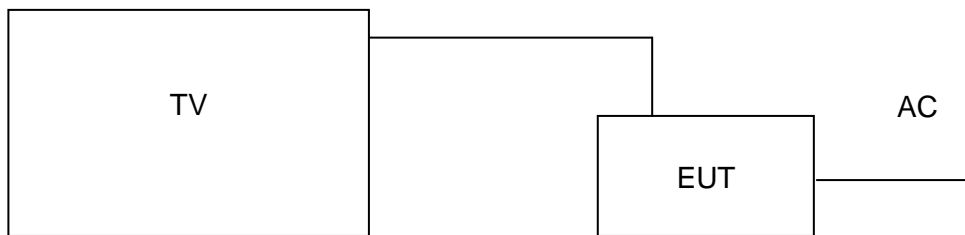

2.4 DESCRIPTION OF SUPPORT UNITS(CONDUCTED MODE)

The EUT has been tested as an independent unit together with other necessary accessories or support units. The following support units or accessories were used to form a representative test configuration during the tests.

Item	Equipment	Mfr/Brand	Model/Type No.	Series No.	Note
1	TV	Sony	S38087	N/A	

Item	Shielded Type	Ferrite Core	Length	Note
1	Unshielded	Without core	0.8	AC input line
2	Unshielded	With core	1.0	DC output line, Model: 7826, Shenzhen Liyuan Technology Co.,Ltd

Note:

- (1) The support equipment was authorized by Declaration of Confirmation.
- (2) For detachable type I/O cable should be specified the length in cm in 『Length』 column.

DongGuan Precise Testing Service Co., Ltd.

Building D, Baoding Technology Park, Guangming Road 2, Guangming Community, Dongcheng District, Dongguan, Guangdong, China

Tel: 86-769-23368601

Fax: 86-769-23368602

http:// www.pts-testing.com

2.5 EQUIPMENTS LIST FOR ALL TEST ITEMS

FOR RADIATED EMISSION TEST (BELOW 1GHZ)

Name of Equipment	Manufacturer	Model	Serial No.	Last Cal.	Next Cal.
EMI Test Receiver	Rohde & Schwarz	ESCI	101417	July 4, 2015	July 3, 2016
Trilog Broadband Antenna (25M-1GHz)	SCHWARZBECK	VULB9160	9160-3355	July 4, 2015	July 3, 2016
Signal Amplifier	SCHWARZBECK	BBV 9475	9745-0013	July 4, 2015	July 3, 2016
RF Cable	SCHWARZBECK	AK9515E	96221	July 4, 2015	July 3, 2016
3m Anechoic Chamber	CHENGYU	966	PTS-001	June 6, 2015	June 5, 2016
MULTI-DEVICE Positioning Controller	Max-Full	MF-7802	MF780208339	N/A	N/A
Active loop antenna (9K-30MHz)	Schwarzbeck	FMZB1519	1519-038	June 6, 2015	June 5, 2016
Spectrum analyzer	Agilent	E4407B	MY46185649	June 6, 2015	June 5, 2016

FOR RADIATED EMISSION TEST (1GHZ ABOVE)

Name of Equipment	Manufacturer	Model	Serial No.	Last Cal.	Next Cal.
EMI Test Receiver	Rohde & Schwarz	ESCI	101417	July 4, 2015	July 3, 2016
Horn Antenna (1G-18GHz)	SCHWARZBECK	BBHA9120D	9120D-1246	July 11, 2015	July 10, 2016
Spectrum Analyzer	Agilent	E4411B	MY4511453	July 4, 2015	July 3, 2016
Signal Amplifier	SCHWARZBECK	BBV 9718	9718-269	July 7, 2015	July 6, 2016
RF Cable	SCHWARZBECK	AK9515H	96220	July 8, 2015	July 7, 2016
3m Anechoic Chamber	CHENGYU	966	PTS-001	June 6, 2015	June 5, 2016
MULTI-DEVICE Positioning Controller	Max-Full	MF-7802	MF780208339	N/A	N/A

DongGuan Precise Testing Service Co., Ltd.

Building D, Baoding Technology Park, Guangming Road 2, Guangming Community, Dongcheng District, Dongguan, Guangdong, China

Tel: 86-769-23368601

Fax: 86-769-23368602

[http:// www.pts-testing.com](http://www.pts-testing.com)

Horn Ant (18G-40GHz)	Schwarzbeck	BBHA 9170	9170-181	June 6, 2015	June 5, 2016
-------------------------	-------------	-----------	----------	--------------	--------------

- Note:** 1. The calibration interval of the above test instruments is 12 months and the calibrations are traceable to CEPREI/CHINA and NIM/CHINA
 2. N/A = No Calibration Request.

FOR CONDUCTED EMISSION TEST:

Name of Equipment	Manufacturer	Model	Serial No.	Last Cal.	Next Cal.
EMI Test Receiver	Rohde & Schwarz	ESCI	101417	July 4, 2015	July 3, 2016
Signal analyzer	Agilent	N9020A	MY51550378	July 8, 2015	July 7, 2016
Signal analyzer	Agilent	E4407B	MY3486729	June 6, 2015	June 5, 2016
Artificial Mains Network	Narda	L2-16B	000WX31025	July 8, 2015	July 7, 2016
Artificial Mains Network (AUX)	Narda	L2-16B	000WX31026	July 8, 2015	July 7, 2016
RF Cable	SCHWARZBECK	AK9515E	96222	July 4, 2015	July 3, 2016
Shielded Room	CHENGYU	843	PTS-002	June 6, 2015	June 5, 2016
Power Meter	Rohde & Schwarz	NRVS	100432	June 6, 2015	June 5, 2016
Power Sensor	Rohde & Schwarz	NRV-Z51	10456	June 6, 2015	June 5, 2016
Power Sensor	Rohde & Schwarz	NRV-Z32	10084	June 6, 2015	June 5, 2016

- Note:** 1. The calibration interval of the above test instruments is 12 months and the calibrations are traceable to CEPREI/CHINA and NIM/CHINA

DongGuan Precise Testing Service Co., Ltd.

Building D, Baoding Technology Park, Guangming Road 2, Guangming Community, Dongcheng District, Dongguan, Guangdong, China

Tel: 86-769-23368601

Fax: 86-769-23368602

[http:// www.pts-testing.com](http://www.pts-testing.com)

3. EMC EMISSION TEST

3.1 CONDUCTED EMISSION MEASUREMENT

3.1.1 POWER LINE CONDUCTED EMISSION Limits (Frequency Range 150KHz-30MHz)

FREQUENCY (MHz)	Class A (dBuV)		Class B (dBuV)		Standard
	Quasi-peak	Average	Quasi-peak	Average	
0.15 -0.5	79.00	66.00	66 - 56 *	56 - 46 *	CISPR
0.50 -5.0	73.00	60.00	56.00	46.00	CISPR
5.0 -30.0	73.00	60.00	60.00	50.00	CISPR

0.15 -0.5	79.00	66.00	66 - 56 *	56 - 46 *	FCC
0.50 -5.0	73.00	60.00	56.00	46.00	FCC
5.0 -30.0	73.00	60.00	60.00	50.00	FCC

Note:

- (1) The tighter limit applies at the band edges.
- (2) The limit of " * " marked band means the limitation decreases linearly with the logarithm of the frequency in the range.

The following table is the setting of the receiver

Receiver Parameters	Setting
Attenuation	10 dB
Start Frequency	0.15 MHz
Stop Frequency	30 MHz
IF Bandwidth	9 kHz

DongGuan Precise Testing Service Co., Ltd.

Building D, Baoding Technology Park, Guangming Road 2, Guangming Community, Dongcheng District, Dongguan, Guangdong, China

Tel: 86-769-23368601

Fax: 86-769-23368602

http:// www.pts-testing.com

3.1.2 TEST PROCEDURE

- a. The EUT was placed 0.8 meters from the horizontal ground plane with EUT being connected to the power mains through a line impedance stabilization network (LISN). All other support equipments powered from additional LISN(s). The LISN provide 50 Ohm/ 50uH of coupling impedance for the measuring instrument.
- b. Interconnecting cables that hang closer than 40 cm to the ground plane shall be folded back and forth in the center forming a bundle 30 to 40 cm long.
- c. I/O cables that are not connected to a peripheral shall be bundled in the center. The end of the cable may be terminated, if required, using the correct terminating impedance. The overall length shall not exceed 1 m.
- d. LISN at least 80 cm from nearest part of EUT chassis.
- e. For the actual test configuration, please refer to the related Item –EUT Test Photos.

3.1.3 DEVIATION FROM TEST STANDARD

No deviation

3.1.4 TEST SETUP

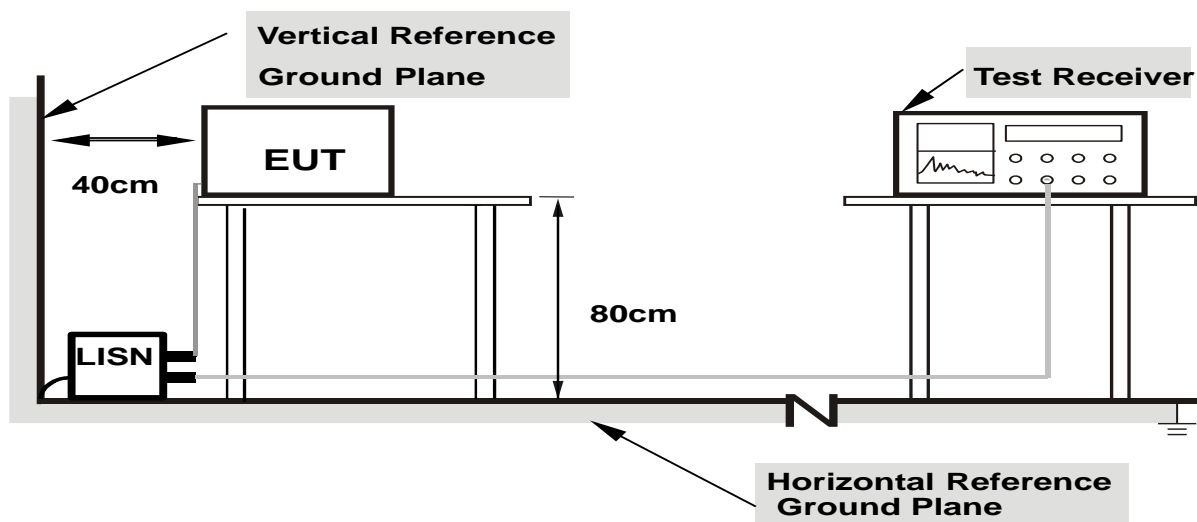

- Note: 1.Support units were connected to second LISN.**
2.Both of LISNs (AMN) are 80 cm from EUT and at least 80 from other units and other metal planes

3.1.5 EUT OPERATING CONDITIONS

The EUT was configured for testing in a typical fashion (as a customer would normally use it). The EUT has been programmed to continuously transmit during test. This operating condition was tested and used to collect the included data.

3.1.6 TEST RESULTS

EUT :	Intel Braswell Fanless Mini PC	Model Name. :	NGC-1
Temperature :	26 °C	Relative Humidity :	54%
Pressure :	1010hPa	Phase :	L
Test Voltage :	AC120V/60Hz	Test Mode :	Mode 7

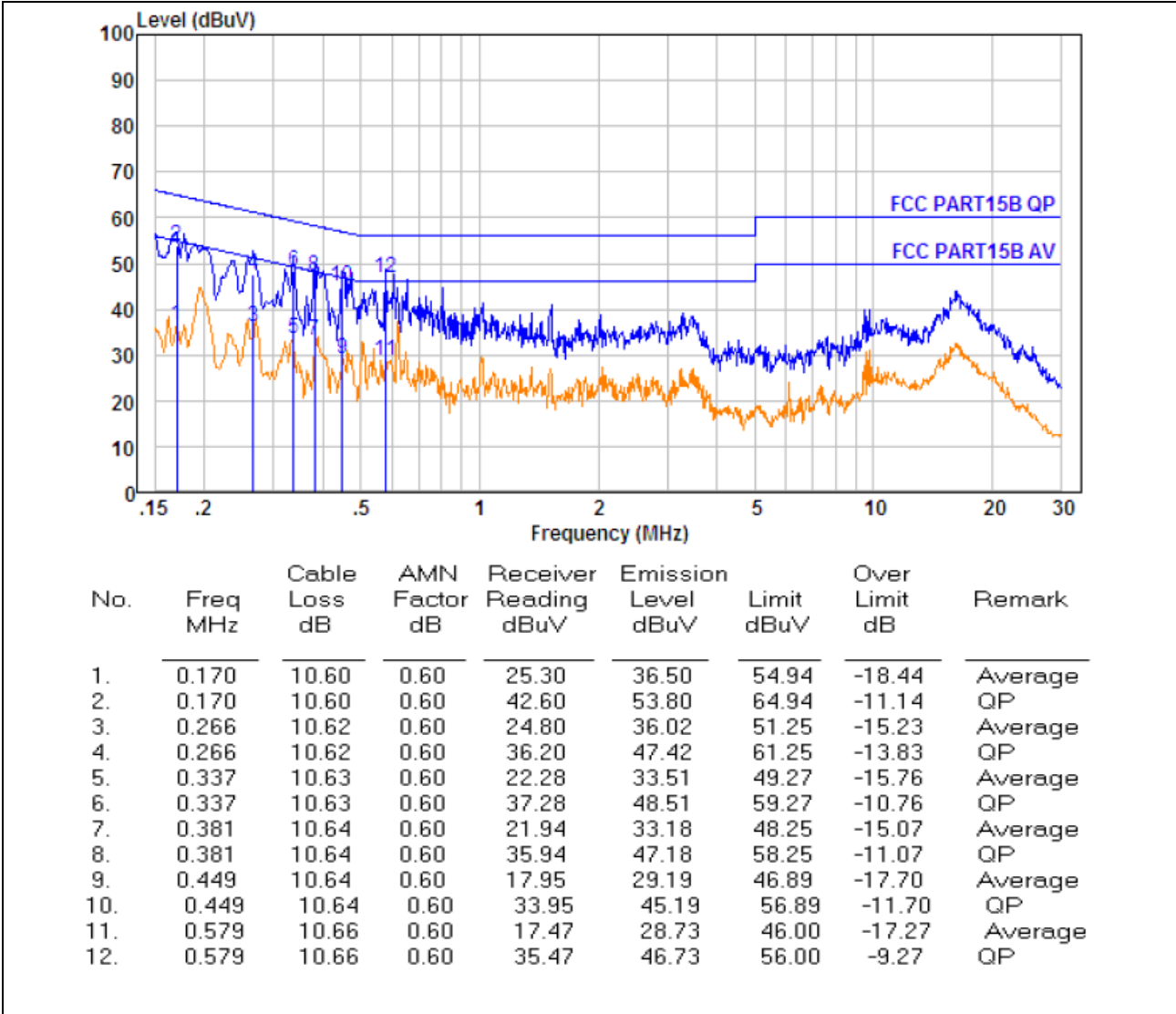

DongGuan Precise Testing Service Co., Ltd.

Building D, Baoding Technology Park, Guangming Road 2, Guangming Community, Dongcheng District, Dongguan, Guangdong, China

Tel: 86-769-23368601

Fax: 86-769-23368602

http:// www.pts-testing.com

EUT :	Intel Braswell Fanless Mini PC	Model Name. :	NGC-1
Temperature :	26 °C	Relative Humidity :	54%
Pressure :	1010hPa	Phase :	N
Test Voltage :	AC120V/60Hz	Test Mode :	Mode 7

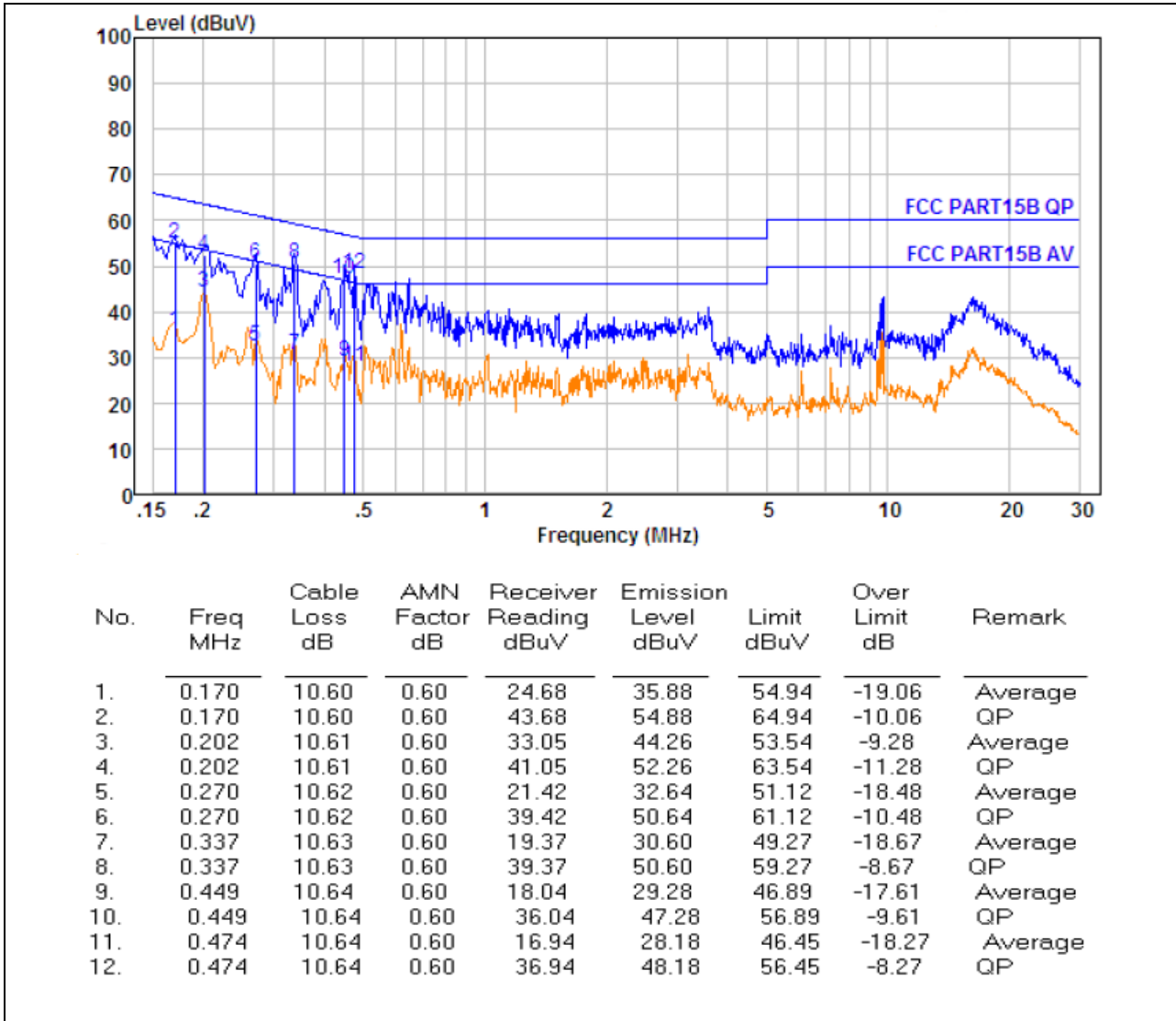

DongGuan Precise Testing Service Co., Ltd.

Building D, Baoding Technology Park, Guangming Road 2, Guangming Community, Dongcheng District, Dongguan, Guangdong, China

Tel: 86-769-23368601

Fax: 86-769-23368602

http:// www.pts-testing.com

EUT :	Intel Braswell Fanless Mini PC	Model Name. :	NGC-1
Temperature :	26 °C	Relative Humidity :	54%
Pressure :	1010hPa	Phase :	L
Test Voltage :	AC 240V/50Hz	Test Mode :	Mode 7

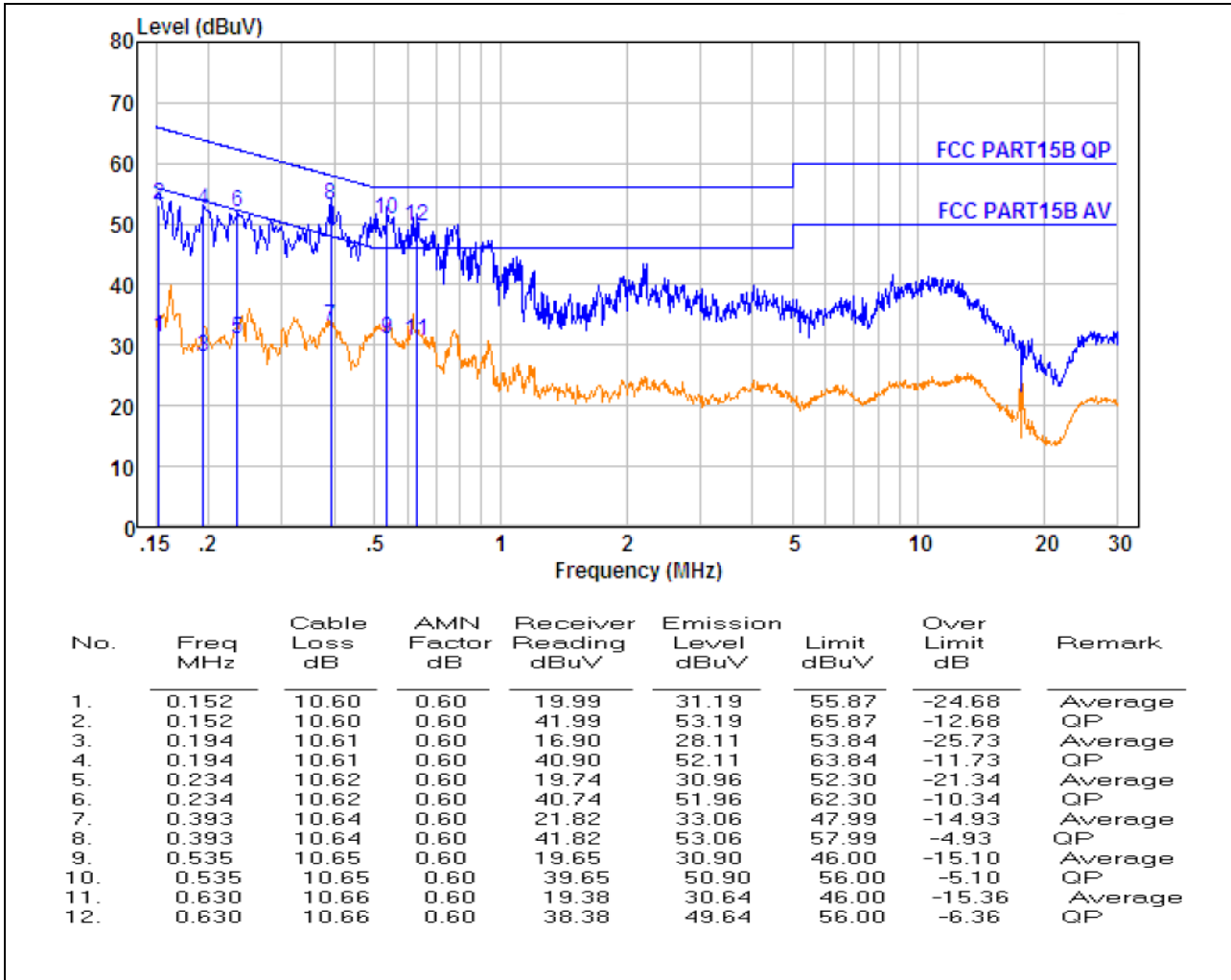

DongGuan Precise Testing Service Co., Ltd.

Building D, Baoding Technology Park, Guangming Road 2, Guangming Community, Dongcheng District, Dongguan, Guangdong, China

Tel: 86-769-23368601

Fax: 86-769-23368602

http:// www.pts-testing.com

EUT :	Intel Braswell Fanless Mini PC	Model Name. :	NGC-1
Temperature :	26 °C	Relative Humidity :	54%
Pressure :	1010hPa	Phase :	N
Test Voltage :	AC 240V/50Hz	Test Mode :	Mode 7

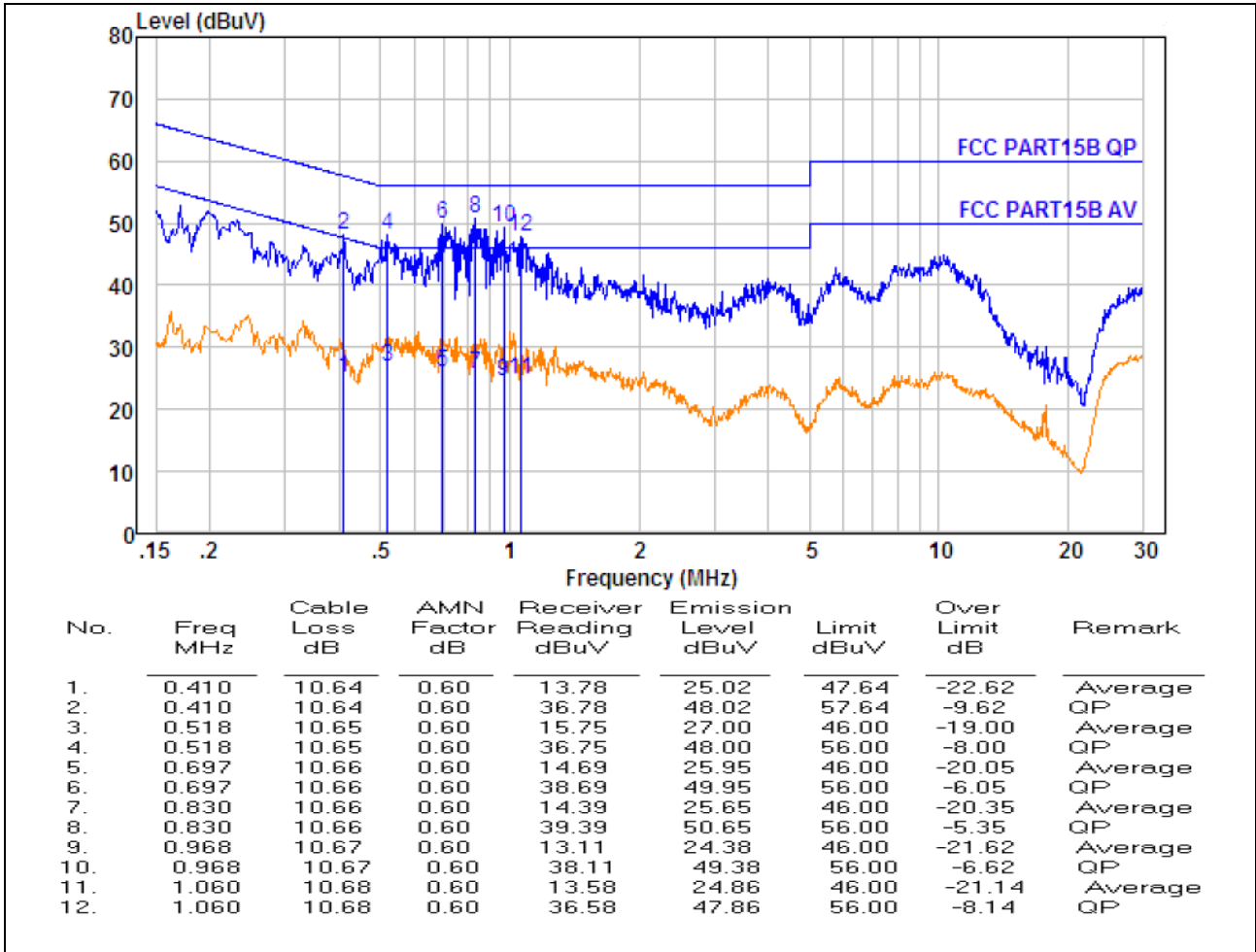

DongGuan Precise Testing Service Co., Ltd.

Building D, Baoding Technology Park, Guangming Road 2, Guangming Community, Dongcheng District, Dongguan, Guangdong, China

Tel: 86-769-23368601

Fax: 86-769-23368602

http:// www.pts-testing.com

3.2 RADIATED EMISSION MEASUREMENT

3.2.1 RADIATED EMISSION LIMITS (Frequency Range 9kHz-1000MHz)

20dBc in any 100 kHz bandwidth outside the operating frequency band. In case the emission fall within the restricted band specified on 15.205(a), then the 15.209(a) limit in the table below has to be followed.

Frequencies (MHz)	Field Strength (micovolts/meter)	Measurement Distance (meters)
0.009~0.490	2400/F(KHz)	300
0.490~1.705	24000/F(KHz)	30
1.705~30.0	30	30
30~88	100	3
88~216	150	3
216~960	200	3
Above 960	500	3

LIMITS OF RADIATED EMISSION MEASUREMENT (Above 1000MHz)

FREQUENCY (MHz)	Class A (dBuV/m) (at 3M)		Class B (dBuV/m) (at 3M)	
	PEAK	AVERAGE	PEAK	AVERAGE
Above 1000	80	60	74	54

Notes:

- (1) The limit for radiated test was performed according to FCC PART 15C.
- (2) The tighter limit applies at the band edges.
- (3) Emission level (dBuV/m)=20log Emission level (uV/m).

Spectrum Parameter	Setting
Attenuation	Auto
Start Frequency	1000 MHz
Stop Frequency	10th carrier harmonic
RB / VB (emission in restricted band)	1 MHz / 1 MHz for Peak, 1 MHz / 10Hz for Average

Receiver Parameter	Setting
Attenuation	Auto
Start ~ Stop Frequency	9kHz~150kHz / RB 200Hz for QP
Start ~ Stop Frequency	150kHz~30MHz / RB 9kHz for QP
Start ~ Stop Frequency	30MHz~1000MHz / RB 120kHz for QP

DongGuan Precise Testing Service Co., Ltd.

Building D, Baoding Technology Park, Guangming Road 2, Guangming Community, Dongcheng District, Dongguan, Guangdong, China

3.2.2 TEST PROCEDURE

- a. The measuring distance of at 3 m shall be used for measurements at frequency up to 1GHz. For frequencies above 1GHz, any suitable measuring distance may be used.
- b. The EUT was placed on the top of a rotating table 0.8 meters above the ground at a 3 meter open area test site. The table was rotated 360 degrees to determine the position of the highest radiation.
- c. The height of the equipment or of the substitution antenna shall be 0.8 m; the height of the test antenna shall vary between 1 m to 4 m. Both horizontal and vertical polarizations of the antenna are set to make the measurement.
- d. The initial step in collecting conducted emission data is a spectrum analyzer peak detector mode pre-scanning the measurement frequency range. Significant peaks are then marked and then Quasi Peak detector mode re-measured.
- e. If the Peak Mode measured value compliance with and lower than Quasi Peak Mode Limit, the EUT shall be deemed to meet QP Limits and then no additional QP Mode measurement performed.
- f. For the actual test configuration, please refer to the related Item –EUT Test Photos.

Note:

Both horizontal and vertical antenna polarities were tested and performed pretest to three orthogonal axis. The worst case emissions were reported

3.2.3 DEVIATION FROM TEST STANDARD

No deviation

3.2.4 TEST SETUP

(A) Radiated Emission Test-Up Frequency Below 30MHz

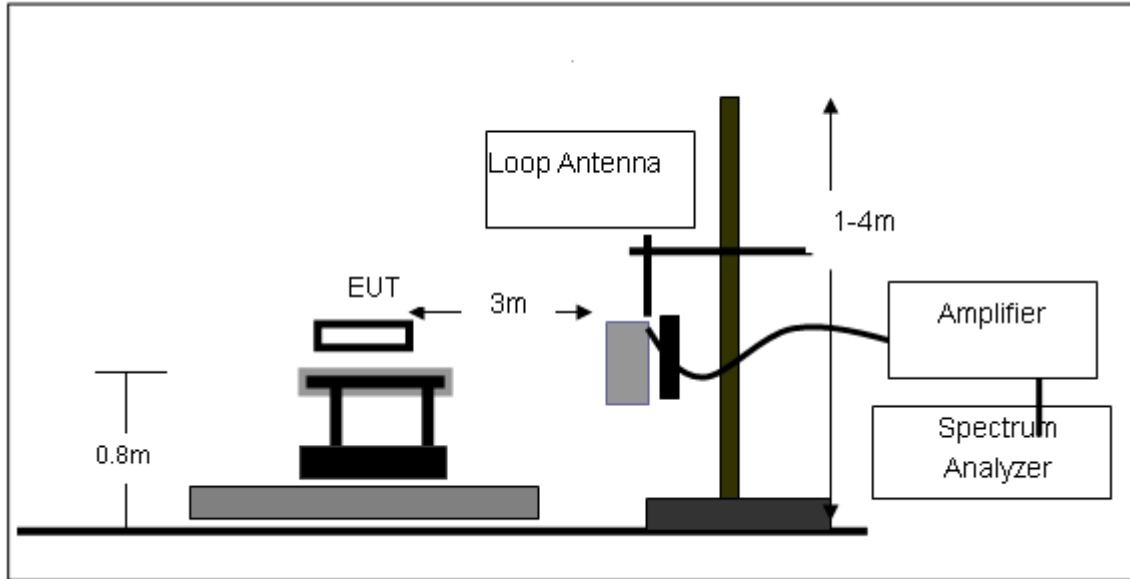

(B) Radiated Emission Test-Up Frequency 30MHz~1GHz

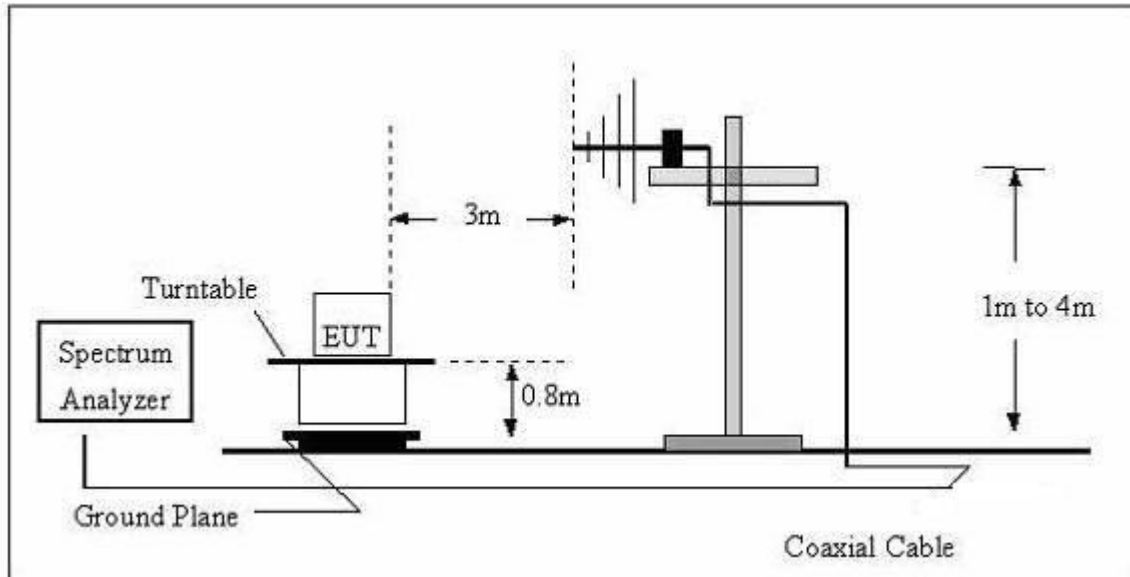

(C) Radiated Emission Test-Up Frequency Above 1GHz

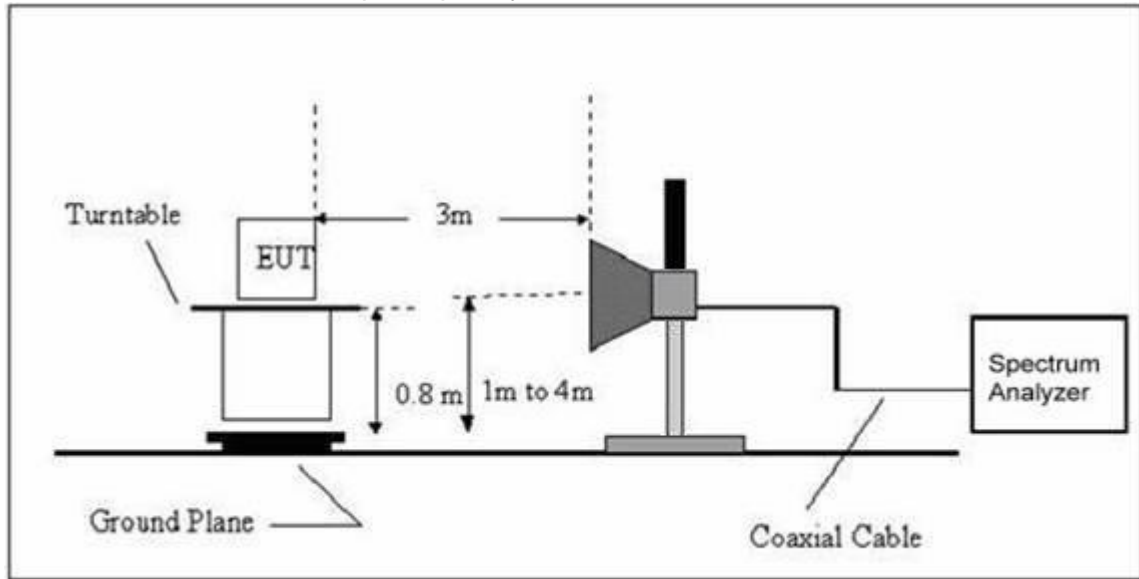

3.2.5 EUT OPERATING CONDITIONS

The EUT tested system was configured as the statements of 2.4 Unless otherwise a special operating condition is specified in the follows during the testing.

3.2.6 TEST RESULTS (BETWEEN 9KHZ – 30 MHZ)

EUT:	Intel Braswell Fanless Mini PC	Model Name. :	NGC-1
Temperature:	20 °C	Relative Humidity:	48%
Pressure:	1010 hPa	Test Voltage :	DC 12.0V
Test Mode :	TX	Polarization :	--

Freq.	Reading	Limit	Margin	State
(MHz)	(dBuV/m)	(dBuV/m)	(dB)	P/F
--	--	--	--	PASS
--	--	--	--	PASS

NOTE:

The amplitude of spurious emissions which are attenuated by more than 20dB below the permissible value has no need to be reported.

Distance extrapolation factor = $40 \log(\text{specific distance/test distance})(\text{dB})$;

Limit line = specific limits(dBuv) + distance extrapolation factor.

3.2.7 TEST RESULTS (BETWEEN 30MHZ – 1GHZ)

EUT :	Intel Braswell Fanless Mini PC	Model Name. :	NGC-1
Temperature :	20 °C	Relative Humidity :	48%
Pressure:	1010 hPa	Test Voltage :	DC 12.0V
Test Mode :	Mode 1		

Test plot for Horizontal:

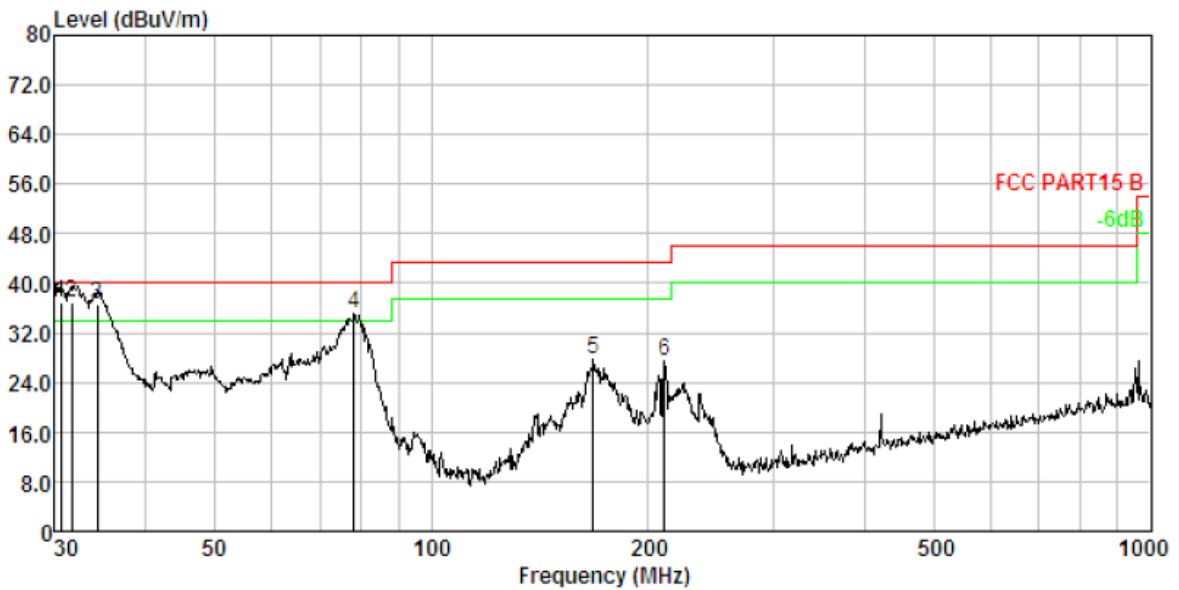

No.	Freq MHz	Cable Loss dB	ANT Factor dB/m	Receiver Reading dBuV	Preamp Factor dB	Emission Level dBuV/m	Limit dBuV/m	Over Limit dB	Remark
1.	30.531	1.07	13.24	52.44	29.98	36.77	40.00	-3.23	QP
2.	31.620	1.10	13.23	52.50	29.99	36.84	40.00	-3.16	QP
3.	34.396	1.18	13.36	52.18	30.02	36.70	40.00	-3.30	QP
4.	78.139	1.92	9.17	54.45	30.30	35.24	40.00	-4.76	QP
5.	167.824	2.61	13.45	42.28	30.57	27.77	43.50	-15.73	QP
6.	210.786	2.82	10.59	44.76	30.65	27.52	43.50	-15.98	QP

Remark:

Absolute Level= ReadingLevel+ Factor, Margin= Limit- Absolute Level

Test plot for Vertical:

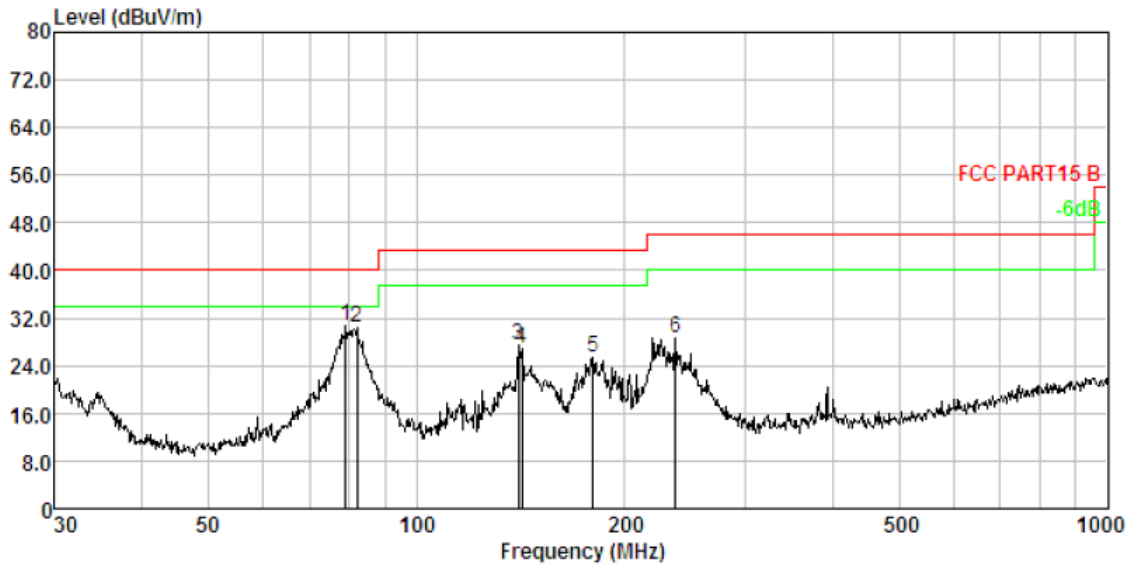

No.	Freq MHz	Cable Loss dB	ANT Factor dB/m	Receiver Reading dBuV	Preamplifier Factor dB	Emission Level dBuV/m	Limit dBuV/m	Over Limit dB	Remark
1.	78.965	1.93	8.99	50.07	30.31	30.68	40.00	-9.32	QP
2.	82.071	1.97	8.73	49.97	30.32	30.35	40.00	-9.65	QP
3.	140.342	2.45	13.38	42.04	30.51	27.36	43.50	-16.14	QP
4.	142.324	2.46	13.49	41.52	30.51	26.96	43.50	-16.54	QP
5.	180.017	2.68	12.44	40.82	30.59	25.35	43.50	-18.15	QP
6.	237.476	2.93	11.59	44.71	30.69	28.54	46.00	-17.46	QP

Remark:

Absolute Level= ReadingLevel+ Factor, Margin= Limit- Absolute Level

3.2.8 TEST RESULTS (ABOVE 1000 MHZ)

802.11a

Normal Voltage

Polar (H/V)	Frequency	Meter Reading	Factor	Emission Level	Limits	Margin	Detector Type
	(GHz)	(dBuV)	(dB)	(dBuV/m)	(dBuV/m)	(dB)	
operation frequency:5180							
V	15.55	60.28	-3.75	56.53	74.00	-17.47	Pk
V	15.55	43.42	-3.75	39.67	54.00	-14.33	AV
H	15.55	60.86	-3.75	57.11	74.00	-16.89	Pk
H	15.55	45.02	-3.75	41.27	54.00	-12.73	AV
Remark:							
Absolute Level= ReadingLevel+ Factor, Margin= Limit- Absolute Level							

802.11a

Normal Voltage

Polar (H/V)	Frequency	Meter Reading	Factor	Emission Level	Limits	Margin	Detector Type
	(GHz)	(dBuV)	(dB)	(dBuV/m)	(dBuV/m)	(dB)	
operation frequency:5200							
V	15.65	60.02	-3.77	56.25	74.00	-17.75	Pk
V	15.65	42.84	-3.77	39.07	54.00	-14.93	AV
H	15.65	61.22	-3.77	57.45	74.00	-16.55	Pk
H	15.65	44.94	-3.77	41.17	54.00	-12.83	AV
Remark:							
Absolute Level= ReadingLevel+ Factor, Margin= Limit- Absolute Level							

802.11a

Normal Voltage

Polar (H/V)	Frequency	Meter Reading	Factor	Emission Level	Limits	Margin	Detector Type
	(GHz)	(dBuV)	(dB)	(dBuV/m)	(dBuV/m)	(dB)	
operation frequency:5240							
V	15.73	59.92	-3.78	56.14	74.00	-17.86	Pk
V	15.73	43.56	-3.78	39.78	54.00	-14.22	AV
H	15.73	61.12	-3.78	57.34	74.00	-16.66	Pk
H	15.73	45.76	-3.78	41.98	54.00	-12.02	AV
Remark:							
Absolute Level= ReadingLevel+ Factor, Margin= Limit- Absolute Level							

DongGuan Precise Testing Service Co., Ltd.

Building D, Baoding Technology Park, Guangming Road 2, Guangming Community, Dongcheng District, Dongguan, Guangdong, China

802.11n(20MHz)

Normal Voltage

Polar (H/V)	Frequency	Meter Reading	Factor	Emission Level	Limits	Margin	Detector Type
	(GHz)	(dBuV)	(dB)	(dBuV/m)	(dBuV/m)	(dB)	
operation frequency:5180							
V	15.55	59.89	-3.75	56.14	74.00	-17.86	Pk
V	15.55	43.42	-3.75	39.67	54.00	-14.33	AV
H	15.55	61.53	-3.75	57.78	74.00	-16.22	Pk
H	15.55	43.99	-3.75	40.24	54.00	-13.76	AV
Remark:							
Absolute Level= ReadingLevel+ Factor, Margin= Limit- Absolute Level							

802.11n(20MHz)

Normal Voltage

Polar (H/V)	Frequency	Meter Reading	Factor	Emission Level	Limits	Margin	Detector Type
	(GHz)	(dBuV)	(dB)	(dBuV/m)	(dBuV/m)	(dB)	
operation frequency:5200							
V	15.65	60.04	-3.77	56.27	74.00	-17.73	Pk
V	15.65	43.60	-3.77	39.83	54.00	-14.17	AV
H	15.65	61.66	-3.77	57.89	74.00	-16.11	Pk
H	15.65	44.18	-3.77	40.41	54.00	-13.59	AV
Remark:							
Absolute Level= ReadingLevel+ Factor, Margin= Limit- Absolute Level							

802.11n(20MHz)

Normal Voltage

Polar (H/V)	Frequency	Meter Reading	Factor	Emission Level	Limits	Margin	Detector Type
	(GHz)	(dBuV)	(dB)	(dBuV/m)	(dBuV/m)	(dB)	
operation frequency:5240							
V	15.73	60.16	-3.78	56.38	74.00	-17.62	Pk
V	15.73	43.09	-3.78	39.31	54.00	-14.69	AV
H	15.73	61.35	-3.78	57.57	74.00	-16.43	Pk
H	15.73	44.68	-3.78	40.90	54.00	-13.10	AV
Remark:							
Absolute Level= ReadingLevel+ Factor, Margin= Limit- Absolute Level							

802.11n(40MHz)

Normal Voltage

Polar (H/V)	Frequency	Meter Reading	Factor	Emission Level	Limits	Margin	Detector Type
	(GHz)	(dBuV)	(dB)	(dBuV/m)	(dBuV/m)	(dB)	
operation frequency:5190							
V	15.58	57.89	-3.75	54.14	74.00	-19.86	Pk
V	15.58	42.30	-3.75	38.55	54.00	-15.45	AV
H	15.58	60.47	-3.75	56.72	74.00	-17.28	Pk
H	15.58	42.81	-3.75	39.06	54.00	-14.94	AV
Remark:							
Absolute Level= ReadingLevel+ Factor, Margin= Limit- Absolute Level							

802.11n(40MHz)

Normal Voltage

Polar (H/V)	Frequency	Meter Reading	Factor	Emission Level	Limits	Margin	Detector Type
	(GHz)	(dBuV)	(dB)	(dBuV/m)	(dBuV/m)	(dB)	
operation frequency:5230							
V	15.69	58.41	-3.78	54.63	74.00	-19.37	Pk
V	15.69	42.67	-3.78	38.89	54.00	-15.11	AV
H	15.69	60.15	-3.78	56.37	74.00	-17.63	Pk
H	15.69	43.59	-3.78	39.81	54.00	-14.19	AV
Remark:							
Absolute Level= ReadingLevel+ Factor, Margin= Limit- Absolute Level							

802.11ac(20MHz)

Normal Voltage

Polar (H/V)	Frequency	Meter Reading	Factor	Emission Level	Limits	Margin	Detector Type
	(GHz)	(dBuV)	(dB)	(dBuV/m)	(dBuV/m)	(dB)	
operation frequency:5180							
V	15.55	60.17	-3.75	56.42	74.00	-17.58	Pk
V	15.55	42.79	-3.75	39.04	54.00	-14.96	AV
H	15.55	61.22	-3.75	57.47	74.00	-16.53	Pk
H	15.55	43.98	-3.75	40.23	54.00	-13.77	AV
Remark:							
Absolute Level= ReadingLevel+ Factor, Margin= Limit- Absolute Level							

802.11ac(20MHz)

Normal Voltage

Polar (H/V)	Frequency	Meter Reading	Factor	Emission Level	Limits	Margin	Detector Type
	(GHz)	(dBuV)	(dB)	(dBuV/m)	(dBuV/m)	(dB)	
operation frequency:5200							
V	15.65	60.21	-3.77	56.44	74.00	-17.56	Pk
V	15.65	42.84	-3.77	39.07	54.00	-14.93	AV
H	15.65	61.23	-3.77	57.46	74.00	-16.54	Pk
H	15.65	44.49	-3.77	40.72	54.00	-13.28	AV
Remark:							
Absolute Level= ReadingLevel+ Factor, Margin= Limit- Absolute Level							

802.11ac(20MHz)

Normal Voltage

Polar (H/V)	Frequency	Meter Reading	Factor	Emission Level	Limits	Margin	Detector Type
	(GHz)	(dBuV)	(dB)	(dBuV/m)	(dBuV/m)	(dB)	
operation frequency:5240							
V	15.73	60.63	-3.78	56.85	74.00	-17.15	Pk
V	15.73	43.02	-3.78	39.24	54.00	-14.76	AV
H	15.73	60.84	-3.78	57.06	74.00	-16.94	Pk
H	15.73	44.06	-3.78	40.28	54.00	-13.72	AV
Remark:							
Absolute Level= ReadingLevel+ Factor, Margin= Limit- Absolute Level							

802.11ac(40MHz)

Normal Voltage

Polar (H/V)	Frequency	Meter Reading	Factor	Emission Level	Limits	Margin	Detector Type
	(GHz)	(dBuV)	(dB)	(dBuV/m)	(dBuV/m)	(dB)	
operation frequency:5190							
V	15.58	57.80	-3.75	54.05	74.00	-19.95	Pk
V	15.58	42.49	-3.75	38.74	54.00	-15.26	AV
H	15.58	60.64	-3.75	56.89	74.00	-17.11	Pk
H	15.58	43.38	-3.75	39.63	54.00	-14.37	AV
Remark:							
Absolute Level= ReadingLevel+ Factor, Margin= Limit- Absolute Level							

802.11ac(40MHz)

Normal Voltage

Polar (H/V)	Frequency	Meter Reading	Factor	Emission Level	Limits	Margin	Detector Type
	(GHz)	(dBuV)	(dB)	(dBuV/m)	(dBuV/m)	(dB)	
operation frequency:5230							
V	15.69	58.50	-3.78	54.72	74.00	-19.28	Pk
V	15.69	42.44	-3.78	38.66	54.00	-15.34	AV
H	15.69	59.90	-3.78	56.12	74.00	-17.88	Pk
H	15.69	43.67	-3.78	39.89	54.00	-14.11	AV
Remark:							
Absolute Level= ReadingLevel+ Factor, Margin= Limit- Absolute Level							

802.11ac(80MHz)

Normal Voltage

Polar (H/V)	Frequency	Meter Reading	Factor	Emission Level	Limits	Margin	Detector Type
	(GHz)	(dBuV)	(dB)	(dBuV/m)	(dBuV/m)	(dB)	
operation frequency:5210							
V	15.63	58.62	-3.77	54.85	74.00	-19.15	Pk
V	15.63	42.01	-3.77	38.24	54.00	-15.76	AV
H	15.63	59.33	-3.77	55.56	74.00	-18.44	Pk
H	15.63	41.88	-3.77	38.11	54.00	-15.89	AV
Remark:							
Absolute Level= ReadingLevel+ Factor, Margin= Limit- Absolute Level							

DongGuan Precise Testing Service Co., Ltd.

Building D, Baoding Technology Park, Guangming Road 2, Guangming Community, Dongcheng District, Dongguan, Guangdong, China

Results of Restricted Band Test:

802.11a

Normal Voltage

Polar (H/V)	Frequency	Meter Reading	Factor	Emission Level	Limits	Margin	Detector Type
	(MHz)	(dBuV)	(dB)	(dBuV/m)	(dBuV/m)	(dB)	
operation frequency:5180							
V	5150.00	55.05	-3.69	51.36	74.00	-22.64	Pk
V	5150.00	39.36	-3.69	35.67	54.00	-18.33	AV
H	5150.00	55.52	-3.69	51.83	74.00	-22.17	Pk
H	5150.00	38.96	-3.69	35.27	54.00	-18.73	AV
Remark:							
Absolute Level= ReadingLevel+ Factor, Margin= Limit- Absolute Level							

802.11a

Normal Voltage

Polar (H/V)	Frequency	Meter Reading	Factor	Emission Level	Limits	Margin	Detector Type
	(MHz)	(dBuV)	(dB)	(dBuV/m)	(dBuV/m)	(dB)	
operation frequency:5240							
V	5350.00	55.45	-3.71	51.74	74.00	-22.26	Pk
V	5350.00	38.85	-3.71	35.14	54.00	-18.86	AV
H	5350.00	55.56	-3.71	51.85	74.00	-22.15	Pk
H	5350.00	39.17	-3.71	35.46	54.00	-18.54	AV
Remark:							
Absolute Level= ReadingLevel+ Factor, Margin= Limit- Absolute Level							

Note: 1.All test modes have been tested and we only record the worst results.

2. Measuring frequencies from 9k~40GHz, No emission found between lowest internal used/generated frequency to 30MHz.

3. Radiated emissions measured in frequency range from 9k~40GHz were made with an instrument using Peak detector mode.

DongGuan Precise Testing Service Co., Ltd.

Building D, Baoding Technology Park, Guangming Road 2, Guangming Community, Dongcheng District, Dongguan, Guangdong, China

Tel: 86-769-23368601

Fax: 86-769-23368602

http:// www.pts-testing.com

4. MAXIMUM CONDUCTED OUTPUT POWER

4.1 APPLIED PROCEDURES / LIMIT

For 5150~5250MHz

For mobile and portable client devices in the 5.15-5.25 GHz band, the maximum conducted output power over the frequency band of operation shall not exceed 250 mW provided the maximum antenna gain does not exceed 6 dBi. In addition, the maximum power spectral density shall not exceed 11 dBm in any 1 megahertz band. If transmitting antennas of directional gain greater than 6 dBi are used, both the maximum conducted output power and the maximum power spectral density shall be reduced by the amount in dB that the directional gain of the antenna exceeds 6 dBi.

4.2 TEST PROCEDURE

The transmitter output (antenna port) was connected to the power sensor. Read the test result from the power meter and record it.

4.3 DEVIATION FROM STANDARD

No deviation.

4.4 TEST SETUP



4.5 EUT OPERATION CONDITIONS

The EUT tested system was configured as the statements of 2.1 Unless otherwise a special operating condition is specified in the follows during the testing.

4.6 TEST RESULTS

EUT :	Intel Braswell Fanless Mini PC	Model Name. :	NGC-1
Temperature :	25 °C	Relative Humidity :	60%
Pressure :	1015 hPa	Test Voltage :	DC 12.0V

Test Channel	Frequency	Conducted Output Power(Avg)		Sum Power	Limit
		Antenna 1	Antenna 2		
	MHz	dBm	dBm	dBm	dBm
TX 802.11a Mode					
CH36	5180	12.44	11.51	/	24
CH40	5200	11.65	10.30	/	24
CH48	5240	11.13	10.05	/	24
TX 802.11n-HT20 Mode					
CH36	5180	10.33	10.18	13.27	21.99
CH40	5200	10.09	9.86	12.99	21.99
CH48	5240	9.12	8.87	12.01	21.99
TX 802.11n-HT40 Mode					
CH38	5190	10.84	10.48	13.67	21.99
CH46	5230	9.00	9.58	12.31	21.99
TX 802.11ac(20MHz) Mode					
CH36	5180	9.91	9.66	12.80	21.99
CH40	5200	9.01	10.15	12.63	21.99
CH48	5240	9.26	9.08	12.18	21.99
TX 802.11ac(40MHz) Mode					
CH38	5190	11.20	10.55	13.90	21.99
CH46	5230	9.29	9.51	12.41	21.99
TX 802.11ac(80MHz) Mode					
CH42	5210	9.66	10.25	12.98	21.99

NOTE: During the test the EUT is in 100% duty cycle transmitting.
 For MIMO the correct Limit = Limit-(Directional gain-6dBi)

DongGuan Precise Testing Service Co., Ltd.

Building D, Baoding Technology Park, Guangming Road 2, Guangming Community, Dongcheng District, Dongguan, Guangdong, China

Tel: 86-769-23368601

Fax: 86-769-23368602

http:// www.pts-testing.com

5. POWER SPECTRAL DENSITY TEST

5.1 APPLIED PROCEDURES / LIMIT

The power spectral density is defined as the highest level of power in dBm per MHz generated by the transmitter within the power envelope. The power spectral density limits as show follow.

Frequency range(MHz)	Power Spectral Density Limit
5150~5250	11 dBm/MHz

5.2 TEST PROCEDURE

1. The transmitter was connected directly to a Spectrum Analyzer through a directional couple.
2. The power was monitored at the coupler port with a Spectrum Analyzer. The power level was set to the maximum level.
3. Set the RBW = 1000 kHz.
4. Set the VBW $\geq 3 \times$ RBW
5. Span=Encompass the entire emissions bandwidth (EBW) of the signal
6. Detector = peak.
7. Sweep time = auto couple.
8. Trace mode = max hold.
9. Allow trace to fully stabilize.
10. Use the peak marker function to determine the maximum power level in any 1MHz band segment within the fundamental EBW.

5.3 DEVIATION FROM STANDARD

No deviation.

5.4 TEST SETUP

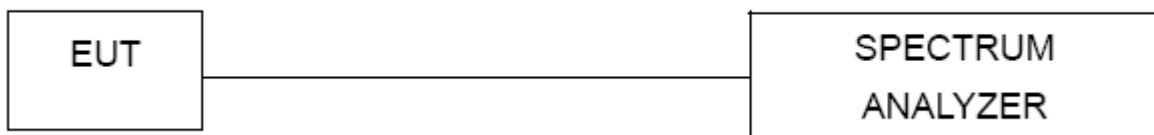

5.5 EUT OPERATION CONDITIONS

The EUT tested system was configured as the statements of 2.4 Unless otherwise a special operating condition is specified in the follows during the testing.

5.6 TEST RESULTS

EUT :	Intel Braswell Fanless Mini PC	Model Name. :	NGC-1
Temperature :	25 °C	Relative Humidity :	60%
Pressure :	1012 hPa	Test Voltage :	DC 12.0V

Channel	Frequency (MHz)	Power Density (dBm/MHz)		Duty cycle factor (dB)	Sum PSD (dBm/MHz)	Max. Limit (dBm/MHz)	Result
		Antenna 1	Antenna 2				
TX 802.11a Mode							
CH36	5180	0.518	0.899	0	/	11	Complies
CH40	5200	0.642	1.176	0	/	11	Complies
CH48	5240	1.002	1.331	0	/	11	Complies
TX 802.11n-HT20 Mode							
CH36	5180	-1.173	0.491	0	2.749	8.99	Complies
CH40	5200	-0.723	-0.078	0	2.622	8.99	Complies
CH48	5240	-0.415	-0.406	0	2.600	8.99	Complies
TX 802.11n-HT40 Mode							
CH38	5190	-2.920	-3.467	0	-0.175	8.99	Complies
CH46	5230	-3.543	-2.824	0	-0.158	8.99	Complies
TX 802.11ac(20MHz) Mode							
CH36	5180	-2.734	-1.599	0	0.881	8.99	Complies
CH40	5200	-1.978	-1.769	0	1.138	8.99	Complies
CH48	5240	-2.121	-1.771	0	1.068	8.99	Complies
TX 802.11ac(40MHz) Mode							
CH38	5190	-5.619	-5.101	0	-2.342	8.99	Complies
CH46	5230	-5.470	-4.726	0	-2.072	8.99	Complies
TX 802.11ac(80MHz) Mode							
CH42	5210	-8.905	-9.151	0	-6.016	8.99	Complies

Duty cycle factor=10log(Ton/Tperiod)=10log[1/100%]dB =0 dB
 For MIMO the correct Limit = Limit-(Directional gain-6dBi)

DongGuan Precise Testing Service Co., Ltd.

Building D, Baoding Technology Park, Guangming Road 2, Guangming Community, Dongcheng District, Dongguan, Guangdong, China

Tel: 86-769-23368601

Fax: 86-769-23368602

http:// www.pts-testing.com



DongGuan Precise Testing Service Co., Ltd.

Building D, Baoding Technology Park, Guangming Road 2, Guangming Community, Dongcheng District, Dongguan, Guangdong, China

Tel: 86-769-23368601

Fax: 86-769-23368602

http:// www.pts-testing.com

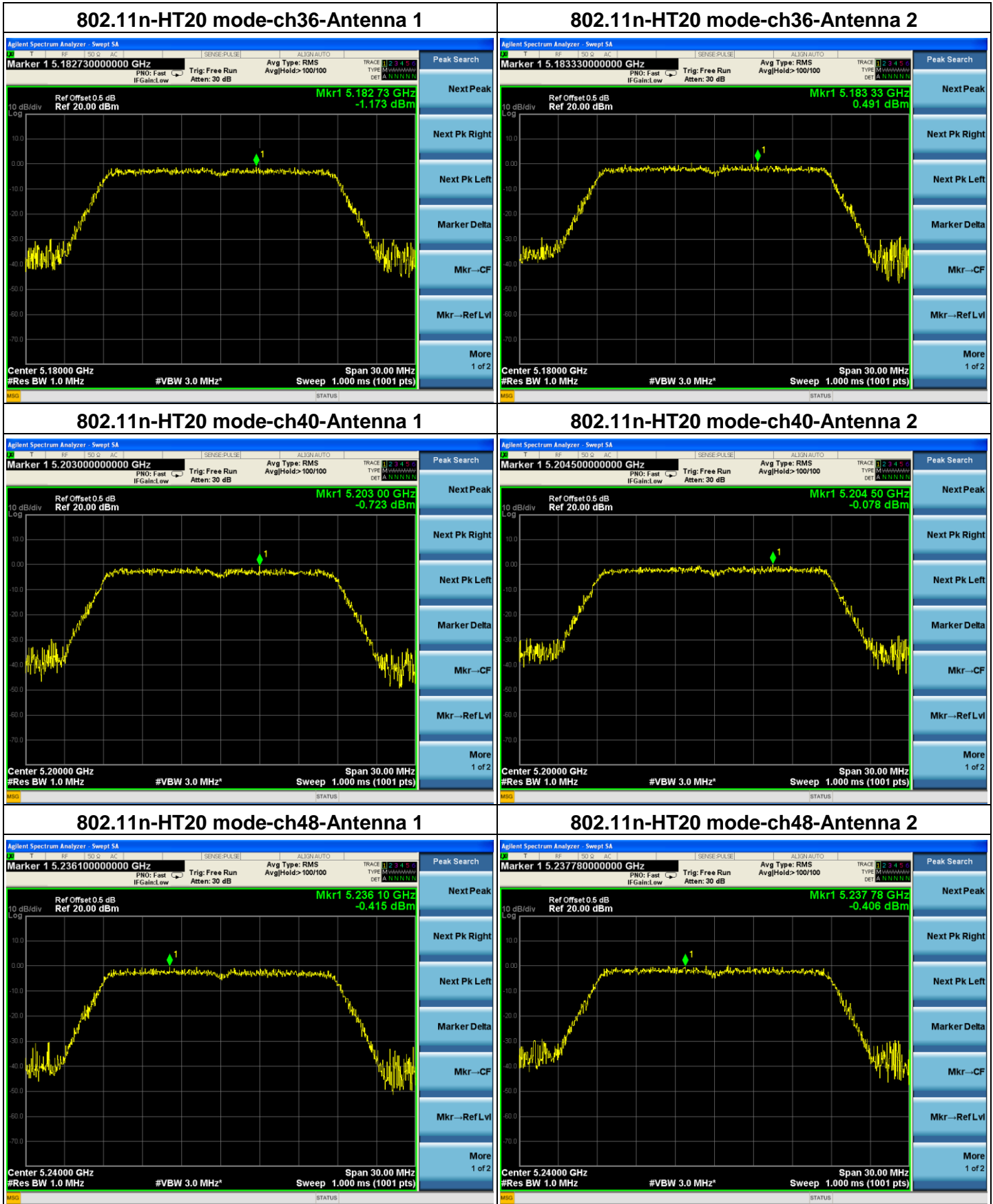

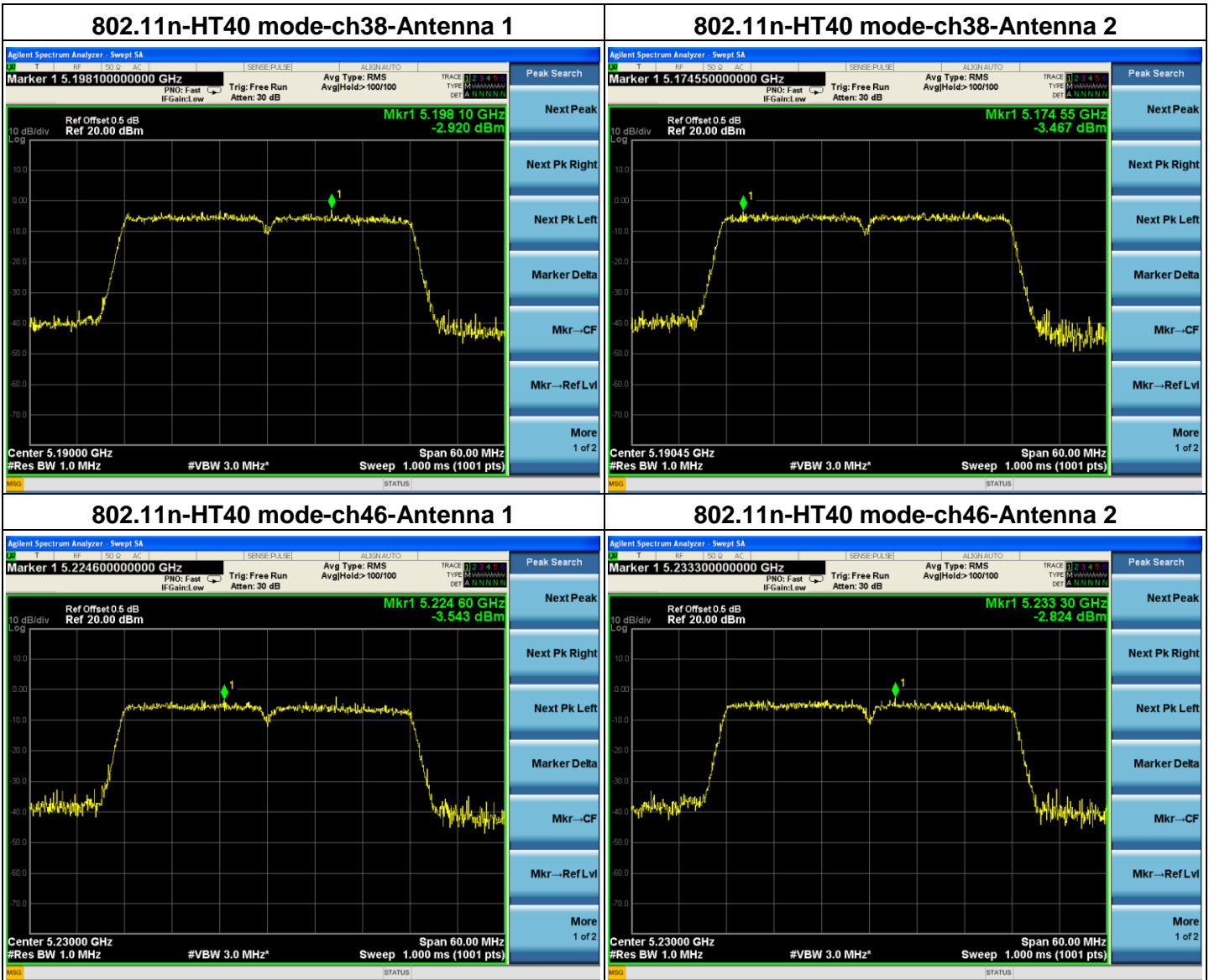

DongGuan Precise Testing Service Co., Ltd.

Building D, Baoding Technology Park, Guangming Road 2, Guangming Community, Dongcheng District, Dongguan, Guangdong, China

Tel: 86-769-23368601

Fax: 86-769-23368602

http:// www.pts-testing.com



DongGuan Precise Testing Service Co., Ltd.

Building D, Baoding Technology Park, Guangming Road 2, Guangming Community, Dongcheng District, Dongguan, Guangdong, China

Tel: 86-769-23368601

Fax: 86-769-23368602

http:// www.pts-testing.com

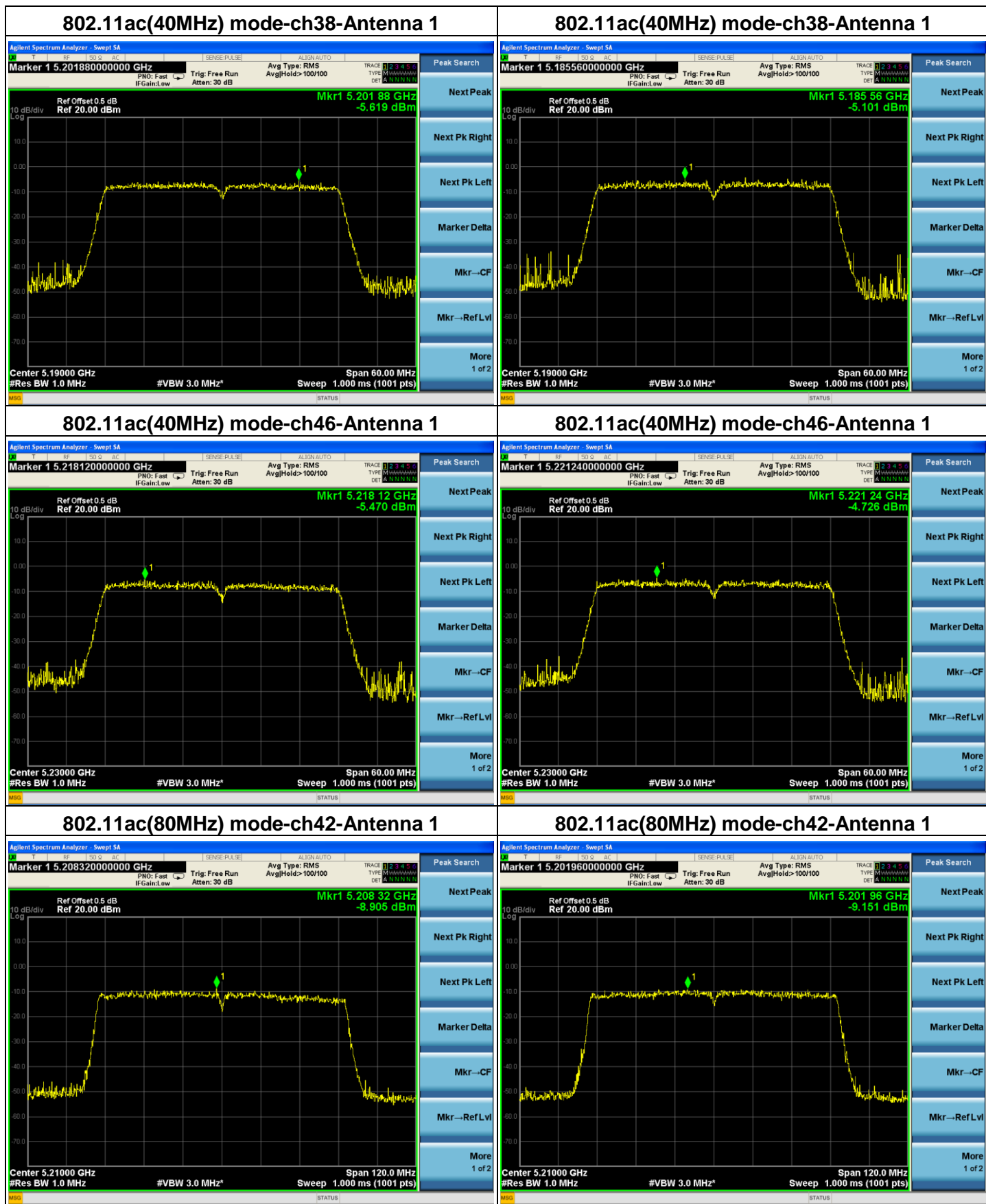

6. 99% AND 26DB OCCUPIED BANDWIDTH TEST

6.1 APPLIED PROCEDURES / LIMIT

No restriction limits. But resolution bandwidth within band edge measurement is 1% of the 99% occupied bandwidth.

6.2 TEST PROCEDURE

1. The transmitter output (antenna port) was connected to the spectrum analyser in peak hold mode.
2. The resolution bandwidth of 300 kHz and the video bandwidth of 1000 kHz were used.
3. Measured the spectrum width with power higher than 26dB below carrier.

6.3 DEVIATION FROM STANDARD

No deviation.

6.4 TEST SETUP



6.5 EUT OPERATION CONDITIONS

The EUT tested system was configured as the statements of 2.4 Unless otherwise a special operating condition is specified in the follows during the testing.

6.6 TEST RESULTS

EUT :	Intel Braswell Fanless Mini PC	Model Name. :	NGC-1
Temperature :	25 °C	Relative Humidity :	60%
Pressure :	1012 hPa	Test Voltage :	DC 12.0V

Test Channel	Frequency (MHz)	26dB Bandwidth (MHz)		99% Occupied Bandwidth (MHz)	
		Antenna 1	Antenna 2	Antenna 1	Antenna 2
TX 802.11a Mode					
CH36	5180	21.21	21.20	16.684	16.690
CH40	5200	21.20	21.21	16.678	16.695
CH48	5240	21.22	21.21	16.678	16.691
TX 802.11n-HT20 Mode					
CH36	5180	21.60	21.75	17.984	18.032
CH40	5200	21.51	21.80	17.966	18.013
CH48	5240	21.69	21.72	17.985	18.003
TX 802.11n-HT40 Mode					
CH38	5190	40.47	40.36	36.673	36.663
CH46	5230	40.33	40.60	36.583	36.682
TX 802.11ac(20MHz) Mode					
CH03	5180	27.63	27.84	17.895	17.853
CH06	5200	26.70	28.51	17.863	17.862
CH09	5240	29.84	27.84	18.484	17.853
TX 802.11ac(40MHz) Mode					
CH38	5190	40.39	40.55	36.521	36.544
CH46	5230	40.43	40.46	36.538	36.572
TX 802.11ac(80MHz) Mode					
CH42	5210	81.44	82.32	75.617	75.630

DongGuan Precise Testing Service Co., Ltd.

Building D, Baoding Technology Park, Guangming Road 2, Guangming Community, Dongcheng District, Dongguan, Guangdong, China

Tel: 86-769-23368601

Fax: 86-769-23368602

[http:// www.pts-testing.com](http://www.pts-testing.com)

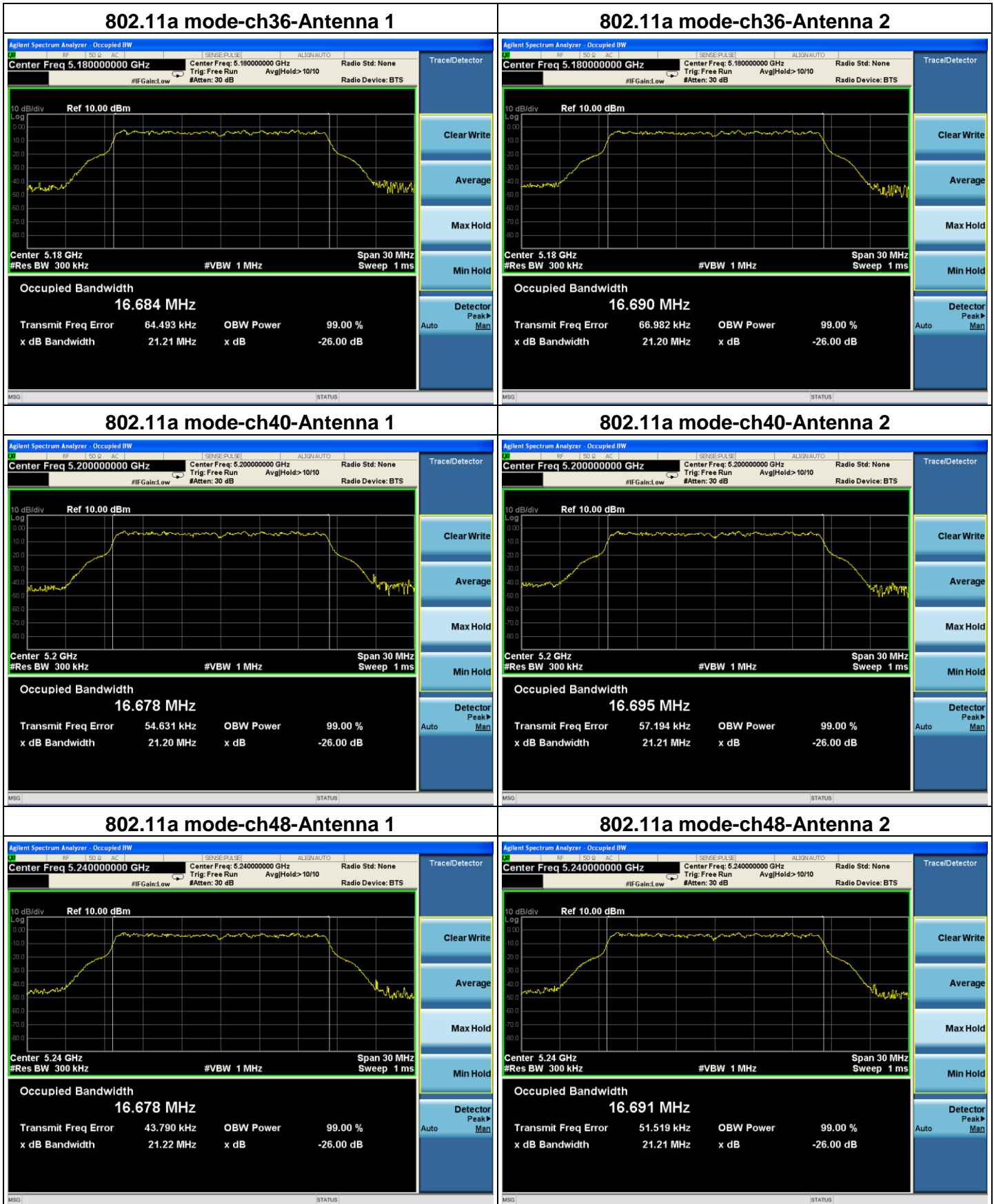

DongGuan Precise Testing Service Co., Ltd.

Building D, Baoding Technology Park, Guangming Road 2, Guangming Community, Dongcheng District, Dongguan, Guangdong, China

Tel: 86-769-23368601

Fax: 86-769-23368602

http:// www.pts-testing.com

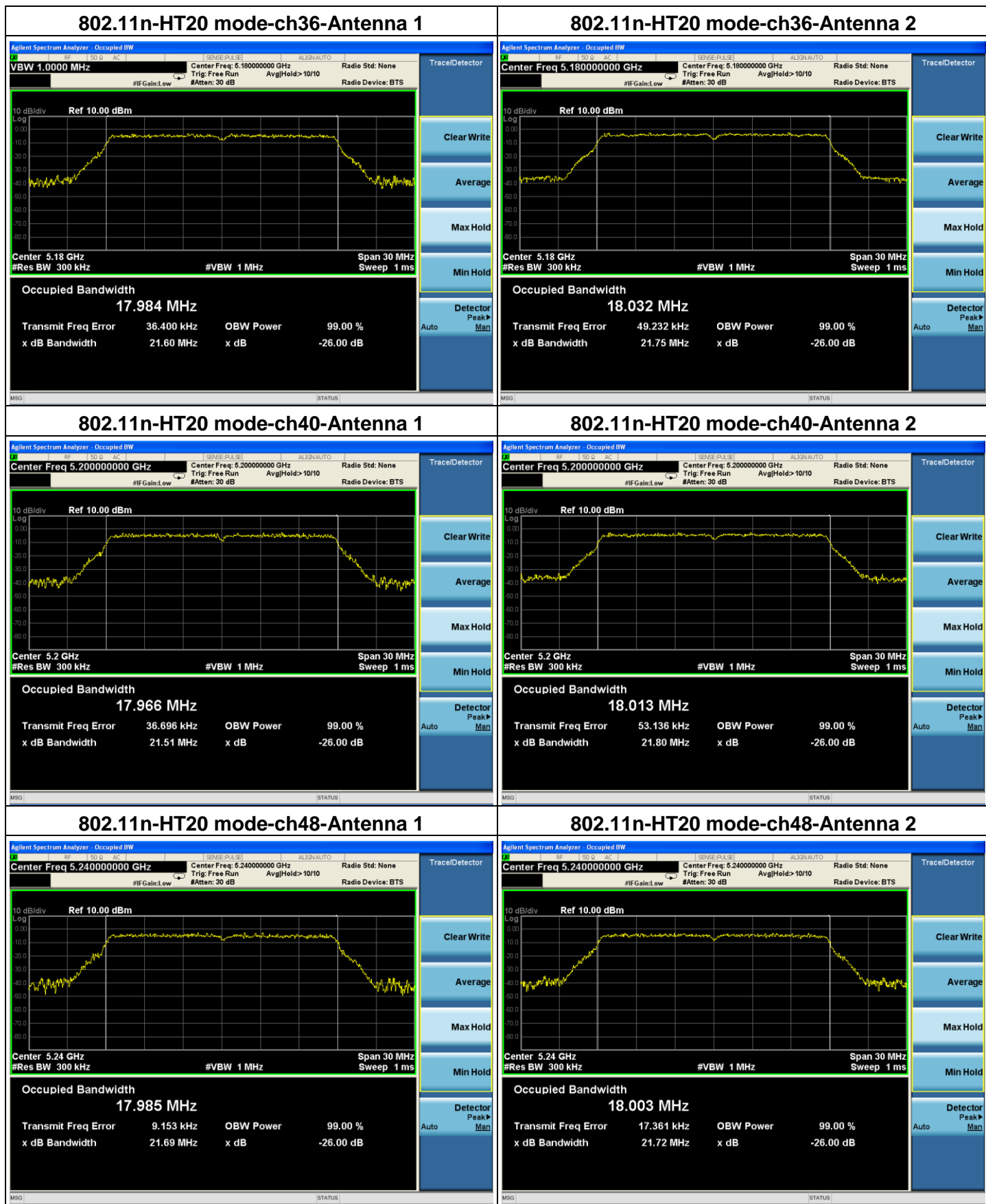

DongGuan Precise Testing Service Co., Ltd.

Building D, Baoding Technology Park, Guangming Road 2, Guangming Community, Dongcheng District, Dongguan, Guangdong, China

Tel: 86-769-23368601

Fax: 86-769-23368602

http:// www.pts-testing.com

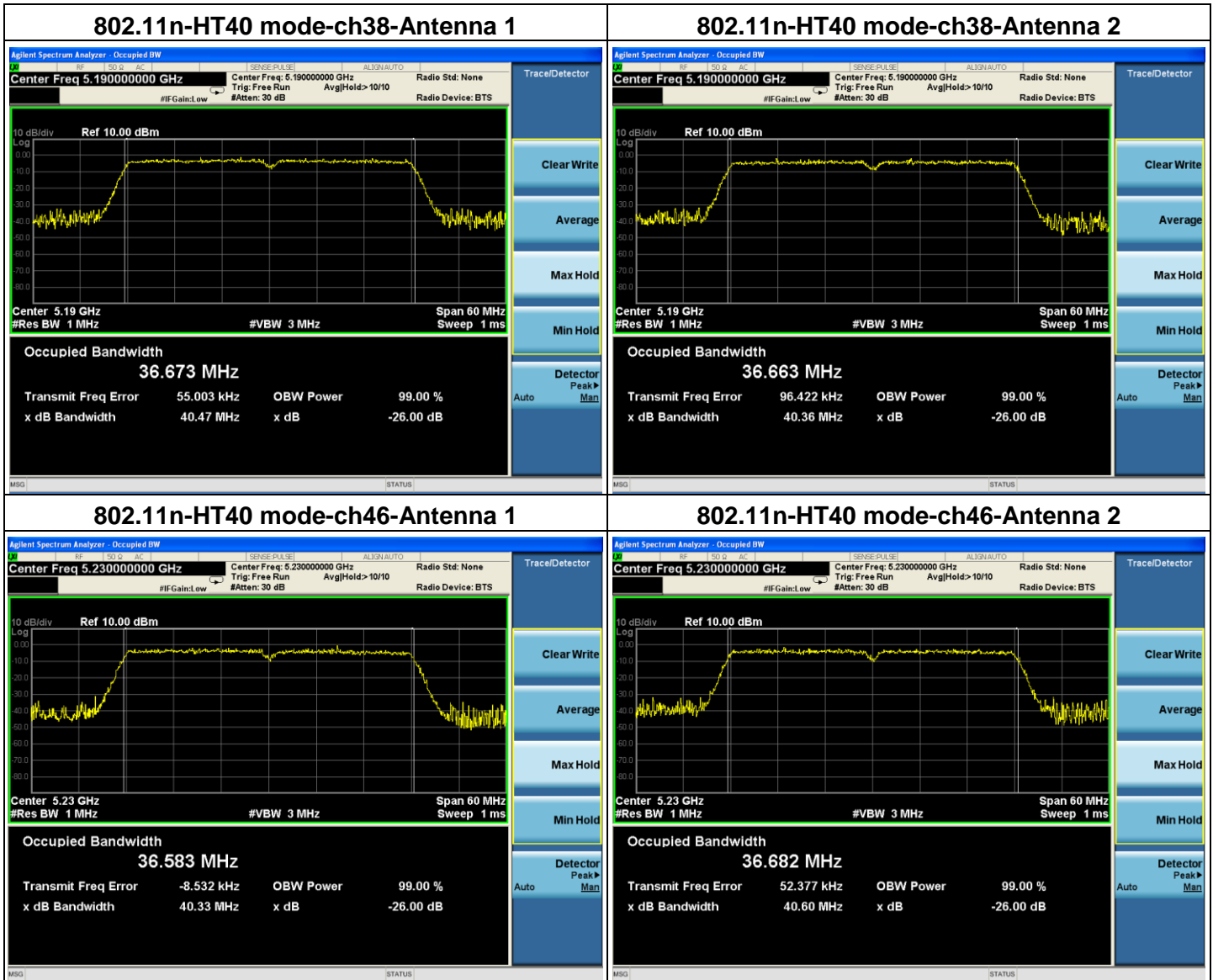

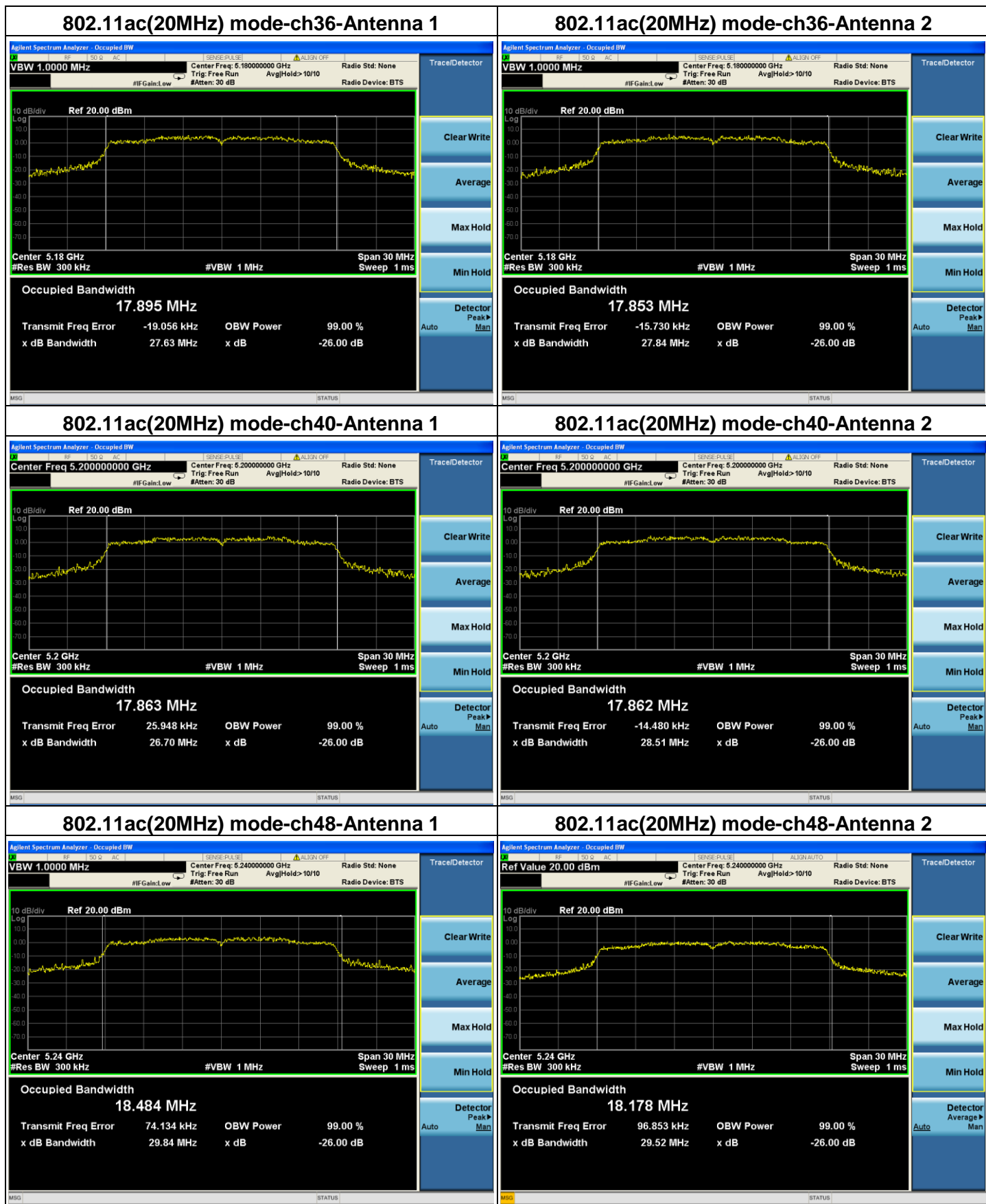

DongGuan Precise Testing Service Co., Ltd.

Building D, Baoding Technology Park, Guangming Road 2, Guangming Community, Dongcheng District, Dongguan, Guangdong, China

Tel: 86-769-23368601

Fax: 86-769-23368602

http:// www.pts-testing.com

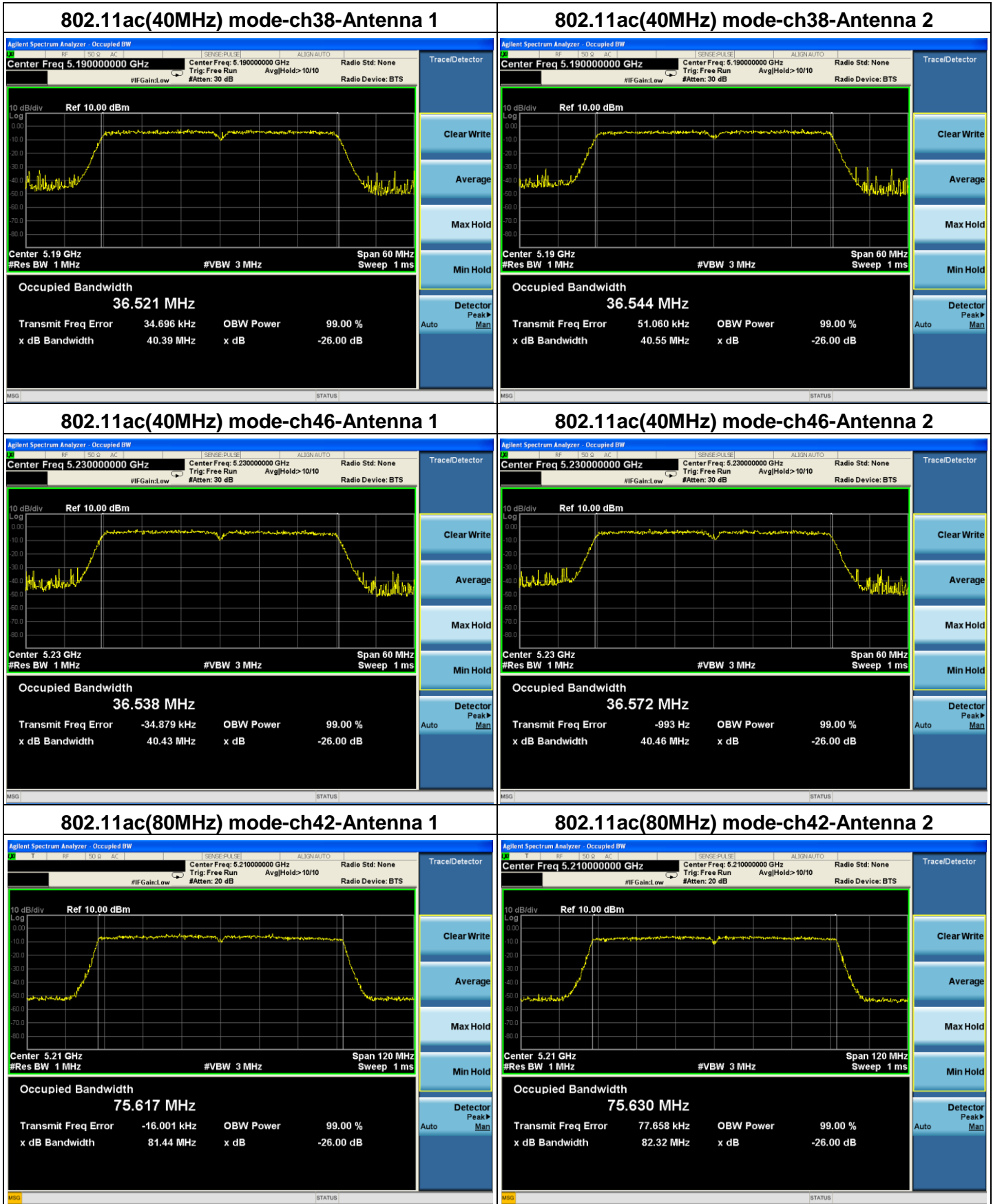

DongGuan Precise Testing Service Co., Ltd.

Building D, Baoding Technology Park, Guangming Road 2, Guangming Community, Dongcheng District, Dongguan, Guangdong, China

Tel: 86-769-23368601

Fax: 86-769-23368602

http:// www.pts-testing.com

7. FREQUENCY STABILITY TEST

7.1 APPLICABLE STANDARD

Manufacturers of U-NII devices are responsible for ensuring frequency stability such that an emissions is maintained within the band of operation under all conditions of normal operation as specified in the user's manual or $\pm 20\text{ppm}$ (IEEE 802.11n specification).

7.2 TEST PROCEDURE

1. The transmitter output (antenna port) was connected to the spectrum analyzer.
2. EUT have transmitted absence of modulation signal and fixed channelize.
3. Set the spectrum analyzer span to view the entire absence of modulation emissions bandwidth.
4. Set RBW = 10 kHz, VBW = 10 kHz with peak detector and maxhold settings.
5. f_c is declaring of channel frequency. Then the frequency error formula is $(f_c - f) / f_c \times 10^6 \text{ ppm}$ and the limit is less than $\pm 20\text{ppm}$ (IEEE 802.11n specification).
6. The test extreme voltage is to change the primary supply voltage from 85 to 115 percent of the nominal value
7. Extreme temperature rule is $-30^\circ\text{C} \sim 50^\circ\text{C}$.

7.3 DEVIATION FROM STANDARD

No deviation.

7.4 TEST SETUP

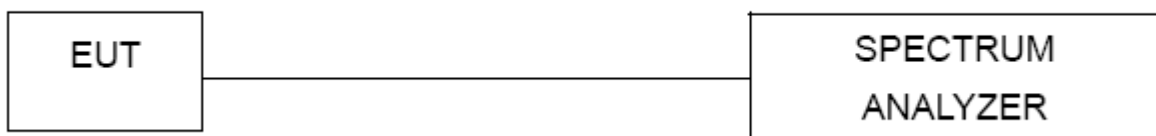

7.5 EUT OPERATION CONDITIONS

The EUT tested system was configured as the statements of 2.4 Unless otherwise a special operating condition is specified in the follows during the testing.

7.6 TEST RESULT FOR CONDUCTED SPURIOUS EMISSIONS TEST

EUT :	Wireless USB Adapter	Model Name :	GWF-5B06
Temperature :	25 °C	Relative Humidity :	60%
Pressure :	1012 hPa	Test Voltage :	DC 12.0V

Test Result for 802.11a:

Voltage vs. Frequency Stability

Voltage (V)	Measure Frequency (MHz)
	5200
10.8	5199.9984
12.0	5199.9967
13.2	5199.9982
Max. Deviation (MHz)	-0.0033
Max. Deviation (ppm)	-0.63

Temperature vs. Frequency Stability

Temperature (°C)	Measure Frequency (MHz)
	5200
-30	5199.9933
-20	5199.9972
-10	5199.9965
0	5199.9912
+10	5199.9976
+20	5199.9985
+30	5199.9966
+40	5199.9977
+50	5199.9943
Max. Deviation (MHz)	-0.0088
Max. Deviation (ppm)	-1.69

Test Result for 802.11n-HT20:

Voltage vs. Frequency Stability

Voltage	Measure Frequency (MHz)
(V)	5200
10.8	5199.9936
12.0	5199.9976
13.2	5199.9945
Max. Deviation (MHz)	-0.0055
Max. Deviation (ppm)	-1.06

Temperature vs. Frequency Stability

Temperature	Measure Frequency (MHz)
(°C)	5200
-30	5199.9962
-20	5199.9983
-10	5199.9977
0	5199.9945
+10	5199.9920
+20	5199.9947
+30	5199.9946
+40	5199.9981
+50	5199.9947
Max. Deviation (MHz)	-0.0080
Max. Deviation (ppm)	-1.54

Test Result for 802.11n-HT40:

Voltage vs. Frequency Stability

Voltage	Measure Frequency (MHz)
(V)	5190
10.8	5190.0043
12.0	5190.0023
13.2	5190.0074
Max. Deviation (MHz)	0.0074
Max. Deviation (ppm)	1.42

Temperature vs. Frequency Stability

Temperature	Measure Frequency (MHz)
(°C)	5190
-30	5190.0034
-20	5190.0055
-10	5190.0072
0	5190.0045
+10	5190.0086
+20	5190.0012
+30	5190.0044
+40	5190.0092
+50	5190.0044
Max. Deviation (MHz)	0.0092
Max. Deviation (ppm)	1.77

DongGuan Precise Testing Service Co., Ltd.

Building D, Baoding Technology Park, Guangming Road 2, Guangming Community, Dongcheng District, Dongguan, Guangdong, China

Test Result for 802.11ac(20MHz):

Voltage vs. Frequency Stability

Voltage	Measure Frequency (MHz)
(V)	5200
10.8	5199.9943
12.0	5199.9967
13.2	5199.9972
Max. Deviation (MHz)	-0.0057
Max. Deviation (ppm)	-1.10

Temperature vs. Frequency Stability

Temperature	Measure Frequency (MHz)
(°C)	5200
-30	5199.9937
-20	5199.9946
-10	5199.9982
0	5199.9944
+10	5199.9911
+20	5199.9993
+30	5199.9935
+40	5199.9972
+50	5199.9953
Max. Deviation (MHz)	-0.0089
Max. Deviation (ppm)	-1.71

Test Result for 802.11ac(40MHz):

Voltage vs. Frequency Stability

Voltage	Measure Frequency (MHz)
(V)	5190
10.8	5190.9963
12.0	5190.9975
13.2	5190.9972
Max. Deviation (MHz)	0.0037
Max. Deviation (ppm)	0.71

Temperature vs. Frequency Stability

Temperature	Measure Frequency (MHz)
(°C)	5190
-30	5190.0044
-20	5190.0012
-10	5190.0045
0	5190.0087
+10	5190.0013
+20	5190.0027
+30	5190.0036
+40	5190.0023
+50	5190.0076
Max. Deviation (MHz)	0.0087
Max. Deviation (ppm)	1.68

DongGuan Precise Testing Service Co., Ltd.

Building D, Baoding Technology Park, Guangming Road 2, Guangming Community, Dongcheng District, Dongguan, Guangdong, China

Tel: 86-769-23368601

Fax: 86-769-23368602

[http:// www.pts-testing.com](http://www.pts-testing.com)

Test Result for 802.11ac(80MHz):

Voltage vs. Frequency Stability

Voltage	Measure Frequency (MHz)
(V)	5210
10.8	5210.0023
12.0	5210.0076
13.2	5210.0028
Max. Deviation (MHz)	0.0076
Max. Deviation (ppm)	1.46

Temperature vs. Frequency Stability

Temperature	Measure Frequency (MHz)
(°C)	5210
-30	5210.0074
-20	5210.0088
-10	5210.0023
0	5210.0045
+10	5210.0072
+20	5210.0048
+30	5210.0023
+40	5210.0061
+50	5210.0047
Max. Deviation (MHz)	0.0088
Max. Deviation (ppm)	1.69

DongGuan Precise Testing Service Co., Ltd.

Building D, Baoding Technology Park, Guangming Road 2, Guangming Community, Dongcheng District, Dongguan, Guangdong, China

Tel: 86-769-23368601

Fax: 86-769-23368602

[http:// www.pts-testing.com](http://www.pts-testing.com)

8. ANTENNA REQUIREMENT

8.1 STANDARD REQUIREMENT

15.203 requirement: For intentional device, according to 15.203: an intentional radiator shall be designed to ensure that no antenna other than that furnished by the responsible party shall be used with the device.

8.2 EUT ANTENNA

The EUT antenna is R-SMA detachable antenna and the gain is 5.0dBi. It's permanent attached antenna. It comply with the standard requirement.

9. EUT TEST PHOTO

Radiated Measurement Photos

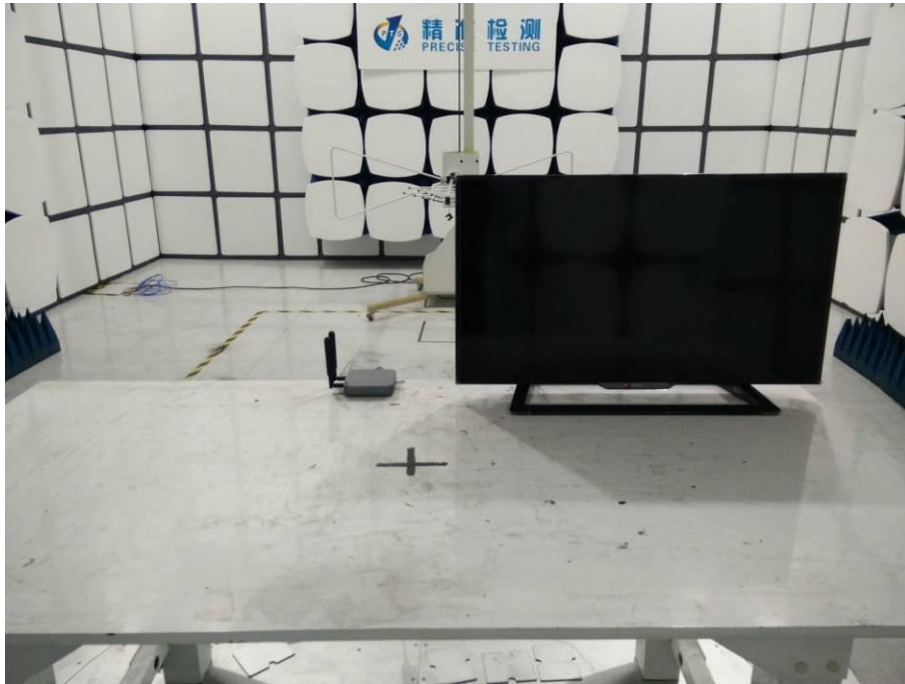

Radiated Measurement Photos

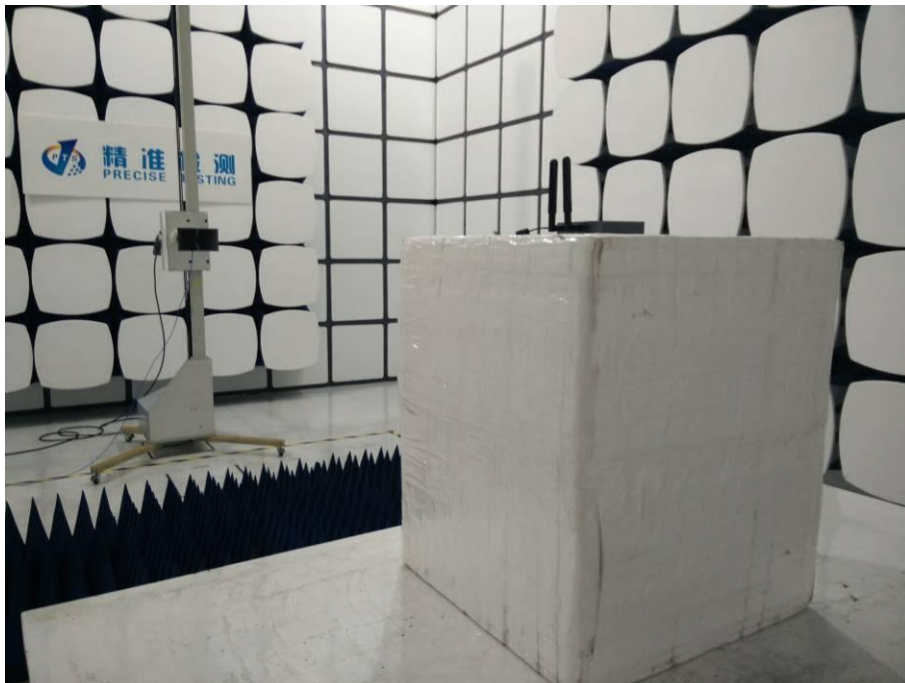

DongGuan Precise Testing Service Co., Ltd.

Building D, Baoding Technology Park, Guangming Road 2, Guangming Community, Dongcheng District, Dongguan, Guangdong, China

Tel: 86-769-23368601

Fax: 86-769-23368602

[http:// www.pts-testing.com](http://www.pts-testing.com)

Conducted Measurement Photos



DongGuan Precise Testing Service Co., Ltd.

Building D, Baoding Technology Park, Guangming Road 2, Guangming Community, Dongcheng District, Dongguan, Guangdong, China

Tel: 86-769-23368601

Fax: 86-769-23368602

[http:// www.pts-testing.com](http://www.pts-testing.com)