

RF TEST REPORT



Report No.: 17070865-FCC-R5-V1

Supersede Report No.: N/A

Applicant	Mobiwire Mobiles (Ningbo) Co.,Ltd	
Product Name	Mobile phone	
Model No.	N552	
Serial No.	N/A	
Test Standard	FCC Part 27: 2016; ANSI/TIA-603-D: 2010	
Test Date	September 09 to 18, 2017	
Issue Date	September 27, 2017	
Test Result	<input checked="" type="checkbox"/> Pass <input type="checkbox"/> Fail	
Equipment complied with the specification	<input checked="" type="checkbox"/>	
Equipment did not comply with the specification	<input type="checkbox"/>	
<i>Loren Luo</i>	<i>David Huang</i>	
Loren Luo Test Engineer	David Huang Checked By	
This test report may be reproduced in full only Test result presented in this test report is applicable to the tested sample only		

Issued by:

SIEMIC (SHENZHEN-CHINA) LABORATORIES

Zone A, Floor 1, Building 2 Wan Ye Long Technology Park

South Side of Zhoushi Road, Bao' an District, Shenzhen, Guangdong China 518108

Phone: +86 0755 2601 4629801 Email: China@siemic.com.cn

Laboratories Introduction

SIEMIC, headquartered in the heart of Silicon Valley, with superior facilities in US and Asia, is one of the leading independent testing and certification facilities providing customers with one-stop shop services for Compliance Testing and Global Certifications.



In addition to testing and certification, SIEMIC provides initial design reviews and compliance management throughout a project. Our extensive experience with China, Asia Pacific, North America, European, and International compliance requirements, assures the fastest, most cost effective way to attain regulatory compliance for the global markets.

Accreditations for Conformity Assessment

Country/Region	Scope
USA	EMC, RF/Wireless, SAR, Telecom
Canada	EMC, RF/Wireless, SAR, Telecom
Taiwan	EMC, RF, Telecom, SAR, Safety
Hong Kong	RF/Wireless, SAR, Telecom
Australia	EMC, RF, Telecom, SAR, Safety
Korea	EMI, EMS, RF, SAR, Telecom, Safety
Japan	EMI, RF/Wireless, SAR, Telecom
Singapore	EMC, RF, SAR, Telecom
Europe	EMC, RF, SAR, Telecom, Safety

Test Report	17070865-FCC-R5-V1
Page	3 of 69

This page has been left blank intentionally.

CONTENTS

1. REPORT REVISION HISTORY	5
2. CUSTOMER INFORMATION.....	5
3. TEST SITE INFORMATION	5
4. EQUIPMENT UNDER TEST (EUT) INFORMATION	6
5. TEST SUMMARY	8
6. MEASUREMENTS, EXAMINATION AND DERIVED RESULTS.....	10
6.1 RF EXPOSURE (SAR)	10
6.2 RF OUTPUT POWER.....	11
6.3 PEAK-AVERAGE RATIO.....	22
6.4 OCCUPIED BANDWIDTH	25
6.5 SPURIOUS EMISSIONS AT ANTENNA TERMINALS	34
6.6 SPURIOUS RADIATED EMISSIONS.....	36
6.7 BAND EDGE	39
6.8 BAND EDGE 27.53(M)	47
6.9 FREQUENCY STABILITY.....	48
ANNEX A. TEST INSTRUMENT.....	51
ANNEX B. EUT AND TEST SETUP PHOTOGRAPHS.....	53
ANNEX C. TEST SETUP AND SUPPORTING EQUIPMENT.....	65
ANNEX C.II. EUT OPERATING CONKITIONS	67
ANNEX D. USER MANUAL / BLOCK DIAGRAM / SCHEMATICS / PARTLIST	68
ANNEX E. DECLARATION OF SIMILARITY	69

1. Report Revision History

Report No.	Report Version	Description	Issue Date
17070865-FCC-R5	NONE	Original	September 19, 2017
17070865-FCC-R5-V1	V1	Updated the GPRS/ EGPRS Multi-slot class data	September 27, 2017

2. Customer information

Applicant Name	Mobiwire Mobiles (Ningbo) Co.,Ltd
Applicant Add	Mobiwire Mobiles, No. 999 Dacheng East Road Fenghua, Zhejiang China
Manufacturer	Mobiwire Mobiles (Ningbo) Co.,Ltd
Manufacturer Add	Mobiwire Mobiles, No. 999 Dacheng East Road Fenghua, Zhejiang China

3. Test site information

Test Lab A:

Lab performing tests	SIEMIC (Shenzhen-China) LABORATORIES
Lab Address	Zone A, Floor 1, Building 2 Wan Ye Long Technology Park South Side of Zhoushi Road, Bao' an District, Shenzhen, Guangdong China 518108
FCC Test Site No.	535293
IC Test Site No.	4842E-1
Test Software	Radiated Emission Program-To Shenzhen v2.0

Test Lab B:

Lab performing tests	SIEMIC (Nanjing-China) Laboratories
Lab Address	2-1 Longcang Avenue Yuhua Economic and Technology Development Park, Nanjing, China
FCC Test Site No.	694825
IC Test Site No.	4842B-1
Test Software	EZ_EMG(ver.lcp-03A1)

Note: We just perform Radiated Spurious Emission above 18GHz in the test Lab. B.

4. Equipment under Test (EUT) Information

Description of EUT:	Mobile phone
Main Model:	N552
Serial Model:	N/A
Date EUT received:	September 08, 2017
Test Date(s):	September 09 to 18, 2017
Equipment Category :	PCE
Antenna Gain:	GSM850: -3dBi PCS1900: -1dBi UMTS-FDD Band V: -3dBi UMTS-FDD Band II: -0.5dBi LTE Band IV: -2dBi WIFI: 1dBi Bluetooth/BLE: 1dBi GPS: 1dBi
Antenna Type:	PIFA antenna
Type of Modulation:	GSM / GPRS: GMSK EGPRS: GMSK,8PSK UMTS-FDD: QPSK LTE Band: QPSK, 16QAM 802.11b/g/n: DSSS, OFDM Bluetooth: GFSK, π /4DQPSK, 8DPSK BLE: GFSK GPS:BPSK
RF Operating Frequency (ies):	GSM850 TX: 824.2 ~ 848.8 MHz; RX: 869.2 ~ 893.8 MHz PCS1900 TX: 1850.2 ~ 1909.8 MHz; RX: 1930.2 ~ 1989.8 MHz UMTS-FDD Band V TX: 826.4 ~ 846.6 MHz; RX: 871.4 ~ 891.6 MHz UMTS-FDD Band II TX:1852.4 ~ 1907.6 MHz; RX: 1932.4 ~ 1987.6 MHz LTE Band IV TX: 1710.7 ~ 1754.3 MHz; RX : 2110.7~ 2154.3 MHz

	<p>WIFI: 802.11b/g/n(20M): 2412-2462 MHz WIFI: 802.11n(40M): 2422-2452 MHz Bluetooth& BLE: 2402-2480 MHz GPS: 1575.42 MHz</p>
Number of Channels:	<p>GSM 850: 124CH PCS1900: 299CH UMTS-FDD Band V: 102CH UMTS-FDD Band II: 277CH WIFI :802.11b/g/n(20M): 11CH WIFI :802.11n(40M): 7CH Bluetooth: 79CH BLE: 40CH GPS:1CH</p>
Maximum Conducted AV Power to Antenna:	<p>LTE Band IV: 23.44 dBm</p>
ERP/EIRP:	<p>LTE Band IV: 21.38 dBm / EIRP</p>
Port:	<p>USB Port, Earphone Port</p>
Input Power:	<p>Adapter: Model: S005UA0500100 Input: AC100-240V~50/60Hz,150mA Output: DC 5.0V,1000mA Battery: Spec: 3.85V, 3000mAh,11.55Wh</p>
Trade Name :	<p>NOBLEX</p>
GPRS/EGPRS Multi-slot class	<p>8/10/11/12</p>
FCC ID:	<p>2ADA4N552</p>

5. Test Summary

The product was tested in accordance with the following specifications.

All testing has been performed according to below product classification:

FCC Rules	Description of Test	Result
§ 1.1307; § 2.1093	RF Exposure (SAR)	Compliance
§2.1046;§ 27.50(c.10); § 27.50(d.4)	RF Output Power	Compliance
§ 27.50(d)	Peak-Average Ratio	Compliance
§ 2.1047	Modulation Characteristics	N/A
§ 2.1049; § 27.53(a.5)	99% & -26 dB Occupied Bandwidth	Compliance
§ 2.1051; § 27.53(h)	Spurious Emissions at Antenna Terminal	Compliance
§ 2.1053;§ 27.53(h)	Field Strength of Spurious Radiation	Compliance
§ 27.53(h)	Out of band emission, Band Edge	Compliance
§ 27.53(m)	Band Edge 27.53(m)	N/A
§ 2.1055; § 27.5(h); § 27.54	Frequency stability vs. temperature Frequency stability vs. voltage	Compliance

Note: Testing was performed by configuring EUT to maximum output power status, the declared output power class for different

Measurement Uncertainty

Parameter	Uncertainty
AC Power Line Conducted Emissions (150kHz~30MHz)	$\pm 3.11\text{dB}$
Radiated Emission(30MHz~1GHz)	$\pm 5.12\text{dB}$
Radiated Emission(1GHz~6GHz)	$\pm 5.34\text{dB}$

6. MEASUREMENTS, EXAMINATION AND DERIVED RESULTS

6.1 RF Exposure (SAR)

Test Result: Pass

The EUT is a portable device, thus requires SAR evaluation;

Please refer to RF Exposure Evaluation Report: 17070865-FCC-H.

6.2 RF Output Power

Temperature	25 °C
Relative Humidity	58%
Atmospheric Pressure	1016mbar
Test date :	September 16, 2017
Tested By :	Loren Luo

Requirement(s):

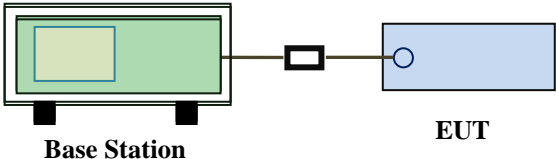
Spec	Item	Requirement	Applicable
§27.50 (c)	c)	EIRP: 30dBm	<input checked="" type="checkbox"/>
Test Setup	 <p style="text-align: center;">Base Station EUT</p>		
Test Procedure	<p>For Conducted Power:</p> <ul style="list-style-type: none"> - The transmitter output port was connected to base station. - Set EUT at maximum power through base station. - Select lowest, middle, and highest channels for each band and different test mode. <p>For ERP/EIRP:</p> <ul style="list-style-type: none"> - The transmitter was placed on a wooden turntable, and it was transmitting into a non-radiating load which was also placed on the turntable. - The measurement antenna was placed at a distance of 3 meters from the EUT. During the tests, the antenna height and polarization as well as EUT azimuth were varied in order to identify the maximum level of emissions from the EUT. The test was performed by placing the EUT on 3-orthogonal axis. - The frequency range up to tenth harmonic of the fundamental frequency was investigated. - Remove the EUT and replace it with substitution antenna. A signal generator was connected to the substitution antenna by a non- 		

	<p>radiating cable. The absolute levels of the spurious emissions were measured by the substitution.</p> <ul style="list-style-type: none"> - Spurious emissions in dB = 10 log (TX power in Watts/0.001) – the absolute level - Spurious attenuation limit in dB = 43 + 10 Log10 (power out in Watts).
Remark	
Result	<input checked="" type="checkbox"/> Pass <input type="checkbox"/> Fail

Test Data Yes N/A

Test Plot Yes (See below) N/A

Conducted Power

LTE Band IV:

BW (MHz)	Ch	Freq. (MHz)	Mode	UL RB Allocation	UL RB Offset	MPR	Average power (dBm)	Tune up Power tolerant
20MHz	20050	1720.0	QPSK	1	0	0	23.31	23±1
				1	49	0	23.36	23±1
				1	99	0	23.38	23±1
				50	0	1	23.41	23±1
				50	24	1	23.26	23±1
				50	49	1	23.35	23±1
			100	0	1	23.35	23±1	
			100	0	2	23.11	23±1	
			16QAM	1	0	1	23.19	23±1
				1	49	1	23.25	23±1
				1	99	1	23.14	23±1
				50	0	2	23.16	23±1
	50	24		2	23.18	23±1		
	50	49		2	23.29	23±1		
	20175	1732.5	QPSK	1	0	0	23.19	22.5±1
				1	49	0	23.14	22.5±1
				1	99	0	23.22	22.5±1
				50	0	1	22.41	22.5±1
				50	24	1	22.48	22.5±1
				50	49	1	22.34	22.5±1
			100	0	1	22.19	22.5±1	
			16QAM	1	0	1	22.19	21.5±1
				1	49	1	22.14	21.5±1
				1	99	1	22.28	21.5±1
50				0	2	21.42	21.5±1	
50				24	2	21.43	21.5±1	
50	49	2		21.36	21.5±1			
20300	1745.0	QPSK	1	0	0	23.38	22.5±1	
			1	49	0	23.44	22.5±1	
			1	99	0	23.33	22.5±1	
			50	0	1	22.62	22.5±1	
			50	24	1	22.55	22.5±1	
			50	49	1	22.57	22.5±1	
		100	0	1	22.31	22.5±1		
		16QAM	1	0	1	22.29	21.5±1	
			1	49	1	22.37	21.5±1	
			1	99	1	22.21	21.5±1	
			50	0	2	21.01	21.5±1	
			50	24	2	20.91	21.5±1	
50	49		2	21.11	21.5±1			
100	0	2	21.28	21.5±1				

BW (MHz)	Ch	Freq. (MHz)	Mode	UL RB Allocation	UL RB Offset	MPR	Average power (dBm)	Tune up Power tolerant
15MHz	20025	1717.5	QPSK	1	0	0	23.23	23.2±1
				1	37	0	23.14	23.2±1
				1	74	0	23.28	23.2±1
				36	0	1	23.17	23.2±1
				36	16	1	23.16	23.2±1
				36	35	1	23.31	23.2±1
			75	0	1	23.19	23.2±1	
			16QAM	1	0	1	23.08	23.1±1
				1	37	1	23.14	23.1±1
				1	74	1	23.15	23.1±1
				36	0	2	22.99	23.1±1
				36	16	2	23.05	23.1±1
	36	35		2	23.03	23.1±1		
	75	0	2	23.18	23.1±1			
	20175	1732.5	QPSK	1	0	0	23.08	22.6±1
				1	37	0	23.01	22.6±1
				1	74	0	23.07	22.6±1
				36	0	1	22.33	22.6±1
				36	16	1	22.42	22.6±1
				36	35	1	22.35	22.6±1
			75	0	1	22.21	22.6±1	
			16QAM	1	0	1	22.27	21.6±1
				1	37	1	22.32	21.6±1
				1	74	1	22.26	21.6±1
				36	0	2	20.95	21.6±1
				36	16	2	20.98	21.6±1
	36	35		2	20.89	21.6±1		
	75	0	2	21.2	21.6±1			
	20325	1747.5	QPSK	1	0	0	23.21	22.8±1
				1	37	0	23.26	22.8±1
1				74	0	23.22	22.8±1	
36				0	1	22.69	22.8±1	
36				16	1	22.72	22.8±1	
36				35	1	22.66	22.8±1	
75			0	1	22.33	22.8±1		
16QAM			1	0	1	22.34	21.9±1	
			1	37	1	22.38	21.9±1	
			1	74	1	22.41	21.9±1	
			36	0	2	21.38	21.9±1	
			36	16	2	21.3	21.9±1	
	36	35	2	21.29	21.9±1			
75	0	2	21.33	21.9±1				

BW (MHz)	Ch	Freq. (MHz)	Mode	UL RB Allocation	UL RB Offset	MPR	Average power (dBm)	Tune up Power tolerant
10MHz	20000	1715.0	QPSK	1	0	0	23.11	23.1±1
				1	24	0	23.19	23.1±1
				1	49	0	23.02	23.1±1
				25	0	1	23.14	23.1±1
				25	12	1	23.21	23.1±1
				25	24	1	23.19	23.1±1
			16QAM	50	0	1	23.01	23.1±1
				1	0	1	23.18	23.2±1
				1	24	1	23.13	23.2±1
				1	49	1	23.12	23.2±1
				25	0	2	23.25	23.2±1
				25	12	2	23.2	23.2±1
	20175	1732.5	QPSK	25	24	2	23.2	23.2±1
				25	24	2	23.2	23.2±1
				50	0	2	23.16	23.2±1
				1	0	0	23.18	22.6±1
				1	24	0	23.13	22.6±1
				1	49	0	23.28	22.6±1
			16QAM	25	0	1	21.98	22.6±1
				25	12	1	22.05	22.6±1
				25	24	1	21.93	22.6±1
				50	0	1	22.11	22.6±1
				1	0	1	22.18	21.6±1
				1	24	1	22.1	21.6±1
	20350	1750.0	QPSK	1	49	1	22.15	21.6±1
				25	0	2	20.94	21.6±1
				25	12	2	20.93	21.6±1
				25	24	2	20.94	21.6±1
				50	0	2	21.16	21.6±1
				1	0	0	23.37	22.8±1
16QAM			1	24	0	23.4	22.8±1	
			1	49	0	23.37	22.8±1	
			25	0	1	22.28	22.8±1	
			25	12	1	22.19	22.8±1	
			25	24	1	22.35	22.8±1	
			50	0	1	22.31	22.8±1	
1	0	1	22.3	21.9±1				
1	24	1	22.28	21.9±1				
1	49	1	22.38	21.9±1				
25	0	2	21.62	21.9±1				
25	12	2	21.57	21.9±1				
25	24	2	21.57	21.9±1				
50	0	2	21.37	21.9±1				

BW (MHz)	Ch	Freq. (MHz)	Mode	UL RB Allocation	UL RB Offset	MPR	Average power (dBm)	Tune up Power tolerant
5MHz	20000	1715.0	QPSK	1	0	0	23.01	23±1
				1	12	0	23.03	23±1
				1	24	0	22.91	23±1
				12	0	1	22.98	23±1
				12	6	1	23.11	23±1
				12	11	1	22.99	23±1
			25	0	1	22.98	23±1	
			16QAM	1	0	1	23.03	23.1±1
				1	12	1	22.97	23.1±1
				1	24	1	23.13	23.1±1
				12	0	2	23.12	23.1±1
				12	6	2	23.01	23.1±1
	12	11		2	22.98	23.1±1		
	25	0	2	23.03	23.1±1			
	20175	1732.5	QPSK	1	0	0	23.03	22.6±1
				1	12	0	23.04	22.6±1
				1	24	0	23.07	22.6±1
				12	0	1	22.08	22.6±1
				12	6	1	22.03	22.6±1
				12	11	1	22.12	22.6±1
			25	0	1	22.12	22.6±1	
			16QAM	1	0	1	22.12	21.7±1
				1	12	1	22.09	21.7±1
				1	24	1	22.21	21.7±1
12				0	2	21.28	21.7±1	
12				6	2	21.27	21.7±1	
12	11	2		21.27	21.7±1			
25	0	2	21.16	21.7±1				
20350	1750.0	QPSK	1	0	0	23.25	22.7±1	
			1	12	0	23.21	22.7±1	
			1	24	0	23.17	22.7±1	
			12	0	1	22.15	22.7±1	
			12	6	1	22.09	22.7±1	
			12	11	1	22.24	22.7±1	
		25	0	1	22.33	22.7±1		
		16QAM	1	0	1	23.3	22.3±1	
			1	12	1	23.26	22.3±1	
			1	24	1	23.25	22.3±1	
			12	0	2	21.56	22.3±1	
			12	6	2	21.47	22.3±1	
12	11		2	21.65	22.3±1			
25	0	2	21.37	22.3±1				

BW (MHz)	Ch	Freq. (MHz)	Mode	UL RB Allocation	UL RB Offset	MPR	Average power (dBm)	Tune up Power tolerant
3MHz	19965	1711.5	QPSK	1	0	0	22.97	23±1
				1	7	0	22.92	23±1
				1	14	0	23.05	23±1
				8	0	1	23.04	23±1
				8	4	1	22.97	23±1
				8	7	1	22.87	23±1
				15	0	1	23.03	23±1
			16QAM	1	0	1	23.13	23.1±1
				1	7	1	23.15	23.1±1
				1	14	1	23.13	23.1±1
				8	0	2	23.18	23.1±1
				8	4	2	23.15	23.1±1
				8	7	2	23.12	23.1±1
				15	0	2	23.07	23.1±1
	20175	1732.5	QPSK	1	0	0	23.13	22.5±1
				1	7	0	23.19	22.5±1
				1	14	0	23.09	22.5±1
				8	0	1	21.95	22.5±1
				8	4	1	21.89	22.5±1
				8	7	1	21.85	22.5±1
				15	0	1	22.11	22.5±1
			16QAM	1	0	1	22.1	21.6±1
				1	7	1	22.12	21.6±1
				1	14	1	22.02	21.6±1
				8	0	2	21.24	21.6±1
				8	4	2	21.23	21.6±1
				8	7	2	21.32	21.6±1
15				0	2	21.07	21.6±1	
20385	1753.5	QPSK	1	0	0	23.38	22.8±1	
			1	7	0	23.4	22.8±1	
			1	14	0	23.37	22.8±1	
			8	0	1	22.28	22.8±1	
			8	4	1	22.23	22.8±1	
			8	7	1	22.38	22.8±1	
			15	0	1	22.3	22.8±1	
		16QAM	1	0	1	22.33	21.7±1	
			1	7	1	22.43	21.7±1	
			1	14	1	22.3	21.7±1	
			8	0	2	21.07	21.7±1	
			8	4	2	21.06	21.7±1	
			8	7	2	21.1	21.7±1	
			15	0	2	21.36	21.7±1	

BW (MHz)	Ch	Freq. (MHz)	Mode	UL RB Allocation	UL RB Offset	MPR	Average power (dBm)	Tune up Power tolerant
1.4MHz	19957	1710.7	QPSK	1	0	0	23.02	23.1±1
				1	2	0	23	23.1±1
				1	5	0	23.09	23.1±1
				3	0	0	23.1	23.1±1
				3	1	0	23.01	23.1±1
				3	2	0	23.01	23.1±1
			16QAM	6	0	1	23.08	23.1±1
				1	0	1	22.92	22.9±1
				1	2	1	22.93	22.9±1
				1	5	1	22.92	22.9±1
				3	0	1	22.87	22.9±1
				3	1	1	22.99	22.9±1
	20175	1732.5	QPSK	3	2	1	23	22.9±1
				6	0	2	22.83	22.9±1
				1	0	0	22.92	22.5±1
				1	2	0	22.92	22.5±1
				1	5	0	22.9	22.5±1
				3	0	0	21.96	22.5±1
			16QAM	3	1	0	21.87	22.5±1
				3	2	0	21.93	22.5±1
				6	0	1	23.11	22.5±1
				1	0	1	21.93	21.3±1
				1	2	1	21.83	21.3±1
				1	5	1	21.86	21.3±1
	20393	1754.3	QPSK	3	0	1	20.67	21.3±1
				3	1	1	20.71	21.3±1
				3	2	1	20.62	21.3±1
				6	0	2	20.8	21.3±1
				1	0	0	23.17	22.6±1
				1	2	0	23.26	22.6±1
16QAM			1	5	0	23.15	22.6±1	
			3	0	0	21.84	22.6±1	
			3	1	0	21.93	22.6±1	
			3	2	0	21.85	22.6±1	
			6	0	1	23.33	22.6±1	
			1	0	1	22.17	21.6±1	
16QAM	1	2	1	22.15	21.6±1			
	1	5	1	22.14	21.6±1			
	3	0	1	20.97	21.6±1			
	3	1	1	20.97	21.6±1			
	3	2	1	21.06	21.6±1			
	6	0	2	21.1	21.6±1			

ERP & EIRP

EIRP for LTE Band IV (Part 27)

Frequency (MHz)	BW (MHz)	Modulation	RB Size/Offset	Substituted level (dBm)	Antenna Polarization	Antenna Gain correction (dBi)	Cable Loss (dB)	Absolute Level (dBm)	Limit (dBm)
1710.7	1.4	QPSK	1/0	13.86	V	7.95	0.79	21.02	30
1732.5	1.4	QPSK	1/0	13.76	V	7.95	0.79	20.92	30
1754.3	1.4	QPSK	1/0	14.01	V	7.95	0.79	21.17	30
1710.7	1.4	QPSK	1/0	12.9	H	7.95	0.79	20.06	30
1732.5	1.4	QPSK	1/0	12.81	H	7.95	0.79	19.97	30
1754.3	1.4	QPSK	1/0	13.07	H	7.95	0.79	20.23	30
1710.7	1.4	16-QAM	1/5	13.76	V	7.95	0.79	20.92	30
1732.5	1.4	16-QAM	1/0	12.67	V	7.95	0.79	19.83	30
1754.3	1.4	16-QAM	1/0	13.01	V	7.95	0.79	20.17	30
1710.7	1.4	16-QAM	1/5	12.82	H	7.95	0.79	19.98	30
1732.5	1.4	16-QAM	1/0	11.8	H	7.95	0.79	18.96	30
1754.3	1.4	16-QAM	1/0	12.08	H	7.95	0.79	19.24	30
1711.5	3	QPSK	1/0	13.81	V	7.95	0.79	20.97	30
1732.5	3	QPSK	1/0	13.97	V	7.95	0.79	21.13	30
1753.5	3	QPSK	1/0	14.22	V	7.95	0.79	21.38	30
1711.5	3	QPSK	1/0	12.88	H	7.95	0.79	20.04	30
1732.5	3	QPSK	1/0	13.1	H	7.95	0.79	20.26	30
1753.5	3	QPSK	1/0	13.27	H	7.95	0.79	20.43	30
1711.5	3	16-QAM	1/0	13.97	V	7.95	0.79	21.13	30
1732.5	3	16-QAM	1/0	12.94	V	7.95	0.79	20.1	30
1753.5	3	16-QAM	1/0	13.17	V	7.95	0.79	20.33	30
1711.5	3	16-QAM	1/0	13.08	H	7.95	0.79	20.24	30
1732.5	3	16-QAM	1/0	11.97	H	7.95	0.79	19.13	30
1753.5	3	16-QAM	1/0	12.26	H	7.95	0.79	19.42	30
1712.5	5	QPSK	1/0	13.85	V	7.95	0.79	21.01	30
1732.5	5	QPSK	1/0	13.87	V	7.95	0.79	21.03	30
1752.5	5	QPSK	1/24	14.01	V	7.95	0.79	21.17	30
1712.5	5	QPSK	1/0	12.91	H	7.95	0.79	20.07	30
1732.5	5	QPSK	1/0	12.93	H	7.95	0.79	20.09	30
1752.5	5	QPSK	1/24	13.07	H	7.95	0.79	20.23	30

1712.5	5	16-QAM	1/0	13.87	V	7.95	0.79	21.03	30
1732.5	5	16-QAM	1/0	12.96	V	7.95	0.79	20.12	30
1752.5	5	16-QAM	1/24	14.09	V	7.95	0.79	21.25	30
1712.5	5	16-QAM	1/0	12.95	H	7.95	0.79	20.11	30
1732.5	5	16-QAM	1/0	12.1	H	7.95	0.79	19.26	30
1752.5	5	16-QAM	1/24	13.17	H	7.95	0.79	20.33	30
1715	10	QPSK	1/0	13.95	V	7.95	0.79	21.11	30
1732.5	10	QPSK	1/49	14.12	V	7.95	0.79	21.28	30
1750	10	QPSK	1/0	14.21	V	7.95	0.79	21.37	30
1715	10	QPSK	1/0	12.99	H	7.95	0.79	20.15	30
1732.5	10	QPSK	1/49	13.18	H	7.95	0.79	20.34	30
1750	10	QPSK	1/0	13.31	H	7.95	0.79	20.47	30
1715	10	16-QAM	1/0	14.02	V	7.95	0.79	21.18	30
1732.5	10	16-QAM	1/49	12.99	V	7.95	0.79	20.15	30
1750	10	16-QAM	1/0	13.14	V	7.95	0.79	20.3	30
1715	10	16-QAM	1/0	13.07	H	7.95	0.79	20.23	30
1732.5	10	16-QAM	1/49	12.01	H	7.95	0.79	19.17	30
1750	10	16-QAM	1/0	12.2	H	7.95	0.79	19.36	30
1717.5	15	QPSK	1/0	14.07	V	7.95	0.79	21.23	30
1732.5	15	QPSK	1/74	13.91	V	7.95	0.79	21.07	30
1747.5	15	QPSK	1/0	14.05	V	7.95	0.79	21.21	30
1717.5	15	QPSK	1/0	13.09	H	7.95	0.79	20.25	30
1732.5	15	QPSK	1/74	13.01	H	7.95	0.79	20.17	30
1747.5	15	QPSK	1/0	13.18	H	7.95	0.79	20.34	30
1717.5	15	16-QAM	1/0	13.92	V	7.95	0.79	21.08	30
1732.5	15	16-QAM	1/74	13.1	V	7.95	0.79	20.26	30
1747.5	15	16-QAM	1/0	13.18	V	7.95	0.79	20.34	30
1717.5	15	16-QAM	1/0	12.93	H	7.95	0.79	20.09	30
1732.5	15	16-QAM	1/74	12.16	H	7.95	0.79	19.32	30
1747.5	15	16-QAM	1/0	12.29	H	7.95	0.79	19.45	30
1720	20	QPSK	1/99	14.22	V	7.95	0.79	21.38	30
1732.5	20	QPSK	1/99	14.06	V	7.95	0.79	21.22	30
1745	20	QPSK	1/0	14.22	V	7.95	0.79	21.38	30
1720	20	QPSK	1/99	13.25	H	7.95	0.79	20.41	30
1732.5	20	QPSK	1/99	13.12	H	7.95	0.79	20.28	30

1745	20	QPSK	1/0	13.26	H	7.95	0.79	20.42	30
1720	20	16-QAM	1/99	13.98	V	7.95	0.79	21.14	30
1732.5	20	16-QAM	1/99	13.12	V	7.95	0.79	20.28	30
1745	20	16-QAM	1/0	13.13	V	7.95	0.79	20.29	30
1720	20	16-QAM	1/99	13.03	H	7.95	0.79	20.19	30
1732.5	20	16-QAM	1/99	12.17	H	7.95	0.79	19.33	30
1745	20	16-QAM	1/0	12.18	H	7.95	0.79	19.34	30

6.3 Peak-Average Ratio

Temperature	25 °C
Relative Humidity	58%
Atmospheric Pressure	1016mbar
Test date :	September 16, 2017
Tested By :	Loren Luo

Requirement(s):

Spec	Item	Requirement	Applicable
§ 27.50(d)	a)	The peak-to-average ratio (PAR) of the transmission may not exceed 13 dB.	<input checked="" type="checkbox"/>

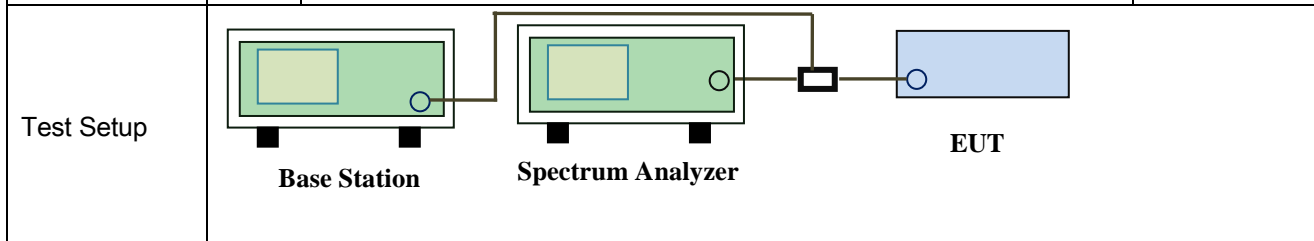

Test Procedure	<p>According with KDB 971168 v02r02</p> <p>5.7.2 Alternate procedure for PAPR</p> <p>5.1.2 Peak power measurements with a peak power meter</p> <p>The total peak output power may be measured using a broadband peak RF power meter. The power meter must have a video bandwidth that is greater than or equal to the emission bandwidth and utilize a fast-responding diode detector.</p> <p>5.2.3 Average power measurement with average power meter</p> <p>As an alternative to the use of a spectrum/signal analyzer or EMI receiver to perform a measurement of the total in-band average output power, a wideband RF average power meter with a thermocouple detector or equivalent can be used under certain conditions</p> <p>If the EUT can be configured to transmit continuously (i.e., the burst duty</p>
----------------	---

	<p>cycle \geq 98%) and at all times the EUT is transmitting at its maximum output power level, then a conventional wide-band RF power meter can be used. If the EUT cannot be configured to transmit continuously (i.e., the burst duty cycle $<$ 98%), then there are two options for the use of an average power meter. First, a gated average power meter can be used to perform the measurement if the gating parameters can be adjusted such that the power is measured only over active transmission bursts at maximum output power levels. A conventional average power meter can also be used if the measured burst duty cycle is constant (i.e., duty cycle variations are less than \pm 2 percent) by performing the measurement over the on/off burst cycles and then correcting (increasing) the measured level by a factor equal to $10\log(1/\text{duty cycle})$</p>
Remark	
Result	<input checked="" type="checkbox"/> Pass <input type="checkbox"/> Fail

Test Data Yes N/A
Test Plot Yes (See below) N/A

LTE Band IV (part 27)

BW(MHz)	Frequency (MHz)	Mode	Modulation	Conducted Power (dBm)		Peak-Average Ratio (PAR)
				Peak	Average	
1.4	1732.5	RB 1/0	QPSK	23.09	22.6	0.49
			16QAM	22.34	21.85	0.49
3	1732.5	RB 1/0	QPSK	23.02	22.65	0.37
			16QAM	21.9	21.6	0.3
5	1732.5	RB 1/0	QPSK	22.93	22.57	0.36
			16QAM	21.96	21.61	0.35
10	1732.5	RB 1/0	QPSK	22.86	22.43	0.43
			16QAM	21.85	21.55	0.3
15	1732.5	RB 1/0	QPSK	22.97	22.59	0.38
			16QAM	21.85	21.55	0.3
20	1732.5	RB 1/0	QPSK	23.04	22.58	0.46
			16QAM	22.06	21.63	0.43

6.4 Occupied Bandwidth

Temperature	25 °C
Relative Humidity	57%
Atmospheric Pressure	1014mbar
Test date :	September 20, 2017
Tested By :	Loren Luo

Requirement(s):

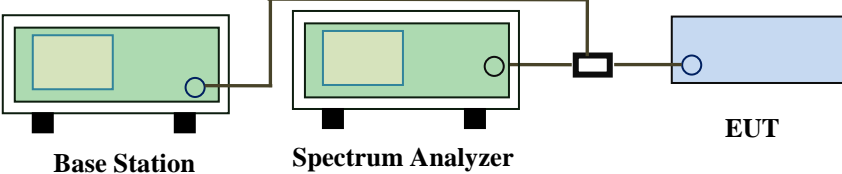
Spec	Item	Requirement	Applicable
§2.1049, §27.53(a)	a)	99% Occupied Bandwidth(kHz)	<input checked="" type="checkbox"/>
	b)	26 dB Bandwidth(kHz)	<input checked="" type="checkbox"/>
Test Setup	 <p style="text-align: center;">Base Station Spectrum Analyzer EUT</p>		
Test Procedure	<ul style="list-style-type: none"> - The EUT was connected to Spectrum Analyzer and Base Station via power divider. - The 99% and 26 dB occupied bandwidth (BW) of the middle channel for the highest RF powers. 		
Remark			
Result	<input checked="" type="checkbox"/> Pass <input type="checkbox"/> Fail		

Test Data Yes N/A

Test Plot Yes (See below) N/A

LTE Band IV (Part 27)

BW(MHz)	Channel	Frequency (MHz)	Modulation	99% Occupied Bandwidth (MHz)	26 dB Bandwidth (MHz)
1.4	19957	1711	16QAM	1.1017	1.289
			QPSK	1.102	1.291
1.4	20175	1733	16QAM	1.1059	1.270
			QPSK	1.1047	1.272
1.4	20393	1754	16QAM	1.0906	1.272
			QPSK	1.0965	1.280
3	19965	1712	16QAM	2.7398	3.040
			QPSK	2.7406	3.043
3	20175	1733	16QAM	2.7451	3.047
			QPSK	2.7404	3.050
3	20385	1754	16QAM	2.7458	3.046
			QPSK	2.7504	3.046
5	19975	1713	16QAM	4.5095	5.061
			QPSK	4.5193	5.066
5	20175	1733	16QAM	4.5252	5.026
			QPSK	4.524	5.064
5	20375	1753	16QAM	4.5126	5.022
			QPSK	4.5163	5.043
10	20000	1715	16QAM	9.0504	10.13
			QPSK	9.0621	10.07
10	20175	1733	16QAM	9.0752	10.15
			QPSK	9.0729	10.13
10	20350	1750	16QAM	9.0669	10.02
			QPSK	9.0743	10.03
15	20025	1718	16QAM	13.48	14.77
			QPSK	13.486	14.83
15	20175	1733	16QAM	13.493	14.77
			QPSK	13.504	14.78
15	20325	1748	16QAM	13.513	14.86
			QPSK	13.506	14.87

20	20050	1720	16QAM	17.880	19.17
			QPSK	17.902	19.22
20	20175	1733	16QAM	17.932	19.46
			QPSK	17.931	19.54
20	20300	1745	16QAM	17.902	19.46
			QPSK	17.871	19.20

Test Plots

LTE Band IV (Part 27)

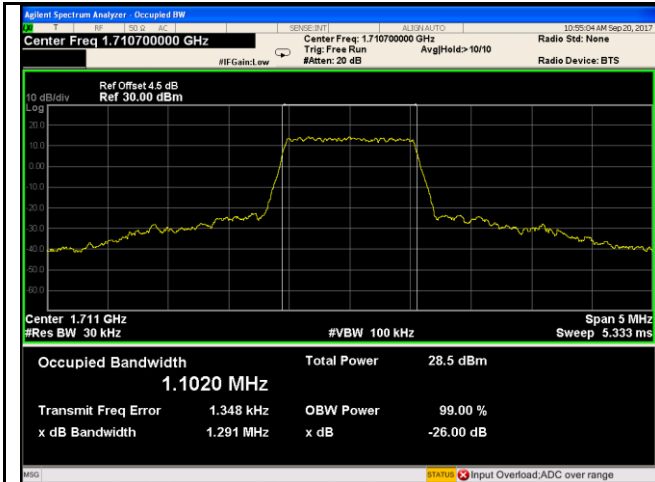

LTE band IV - Low CH QPSK-1.4

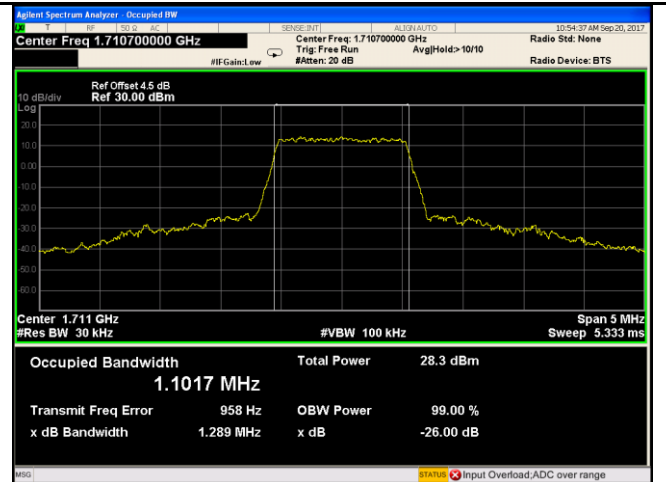

LTE band IV - Low CH 16QAM-1.4

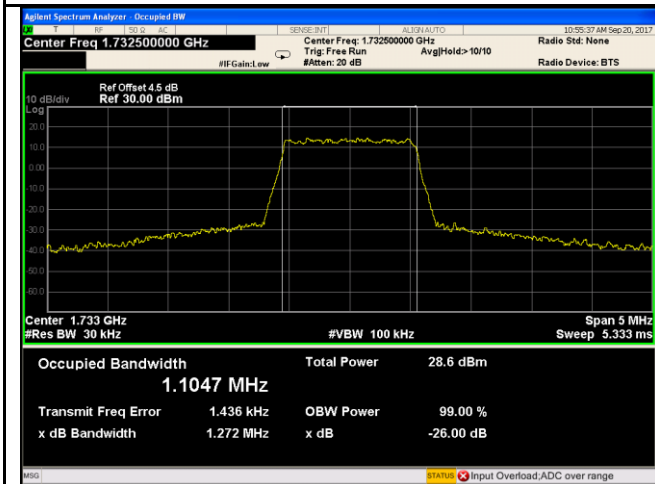

LTE band IV - Middle CH QPSK-1.4

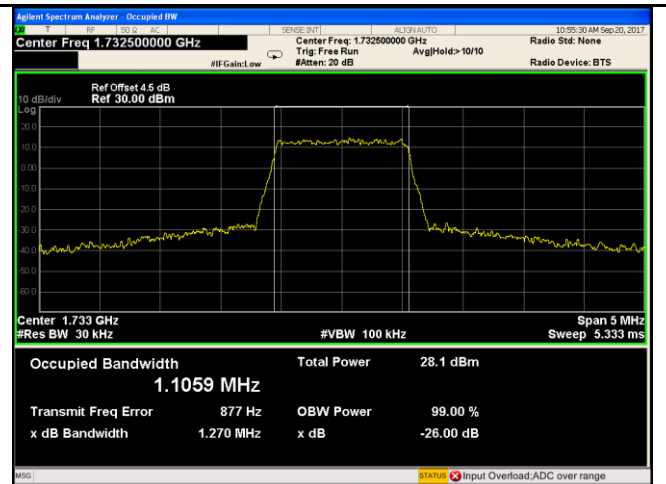

LTE band IV - Middle CH 16QAM-1.4

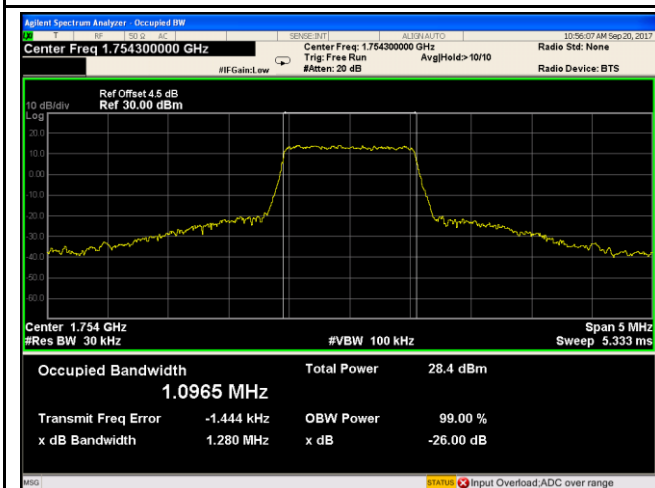

LTE band IV - High CH QPSK-1.4

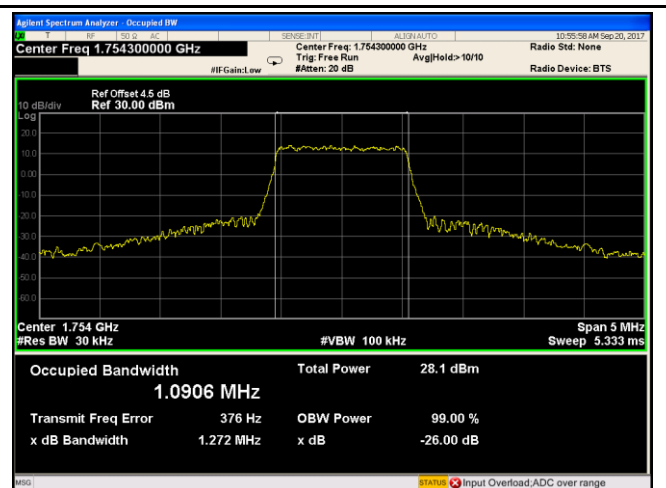

LTE band IV - High CH 16QAM-1.4

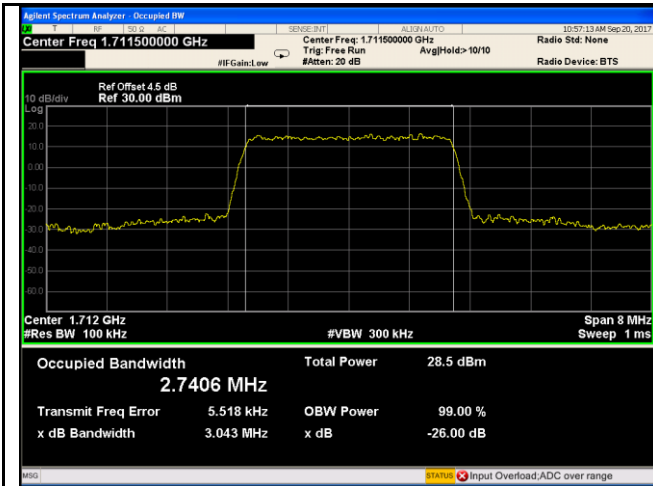

LTE band IV - Low CH QPSK-3

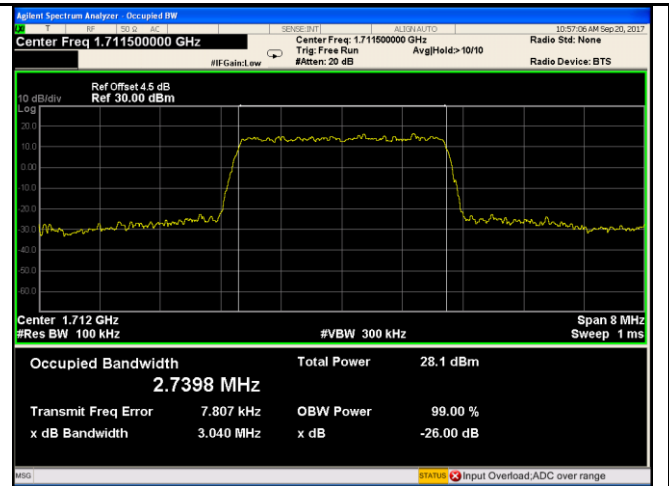

LTE band IV - Low CH 16QAM-3

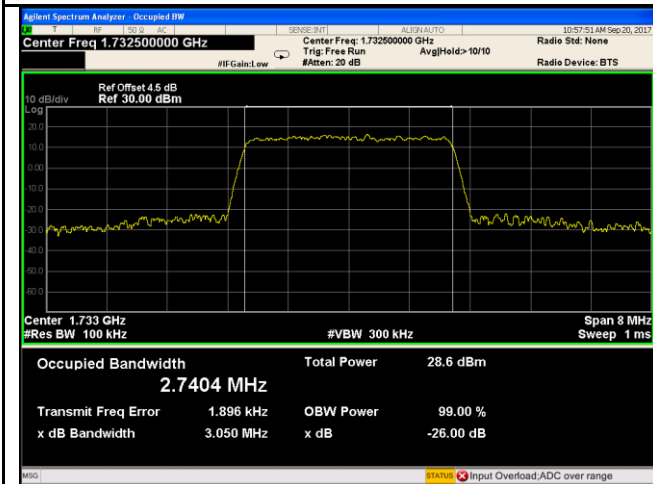

LTE band IV - Middle CH QPSK-3

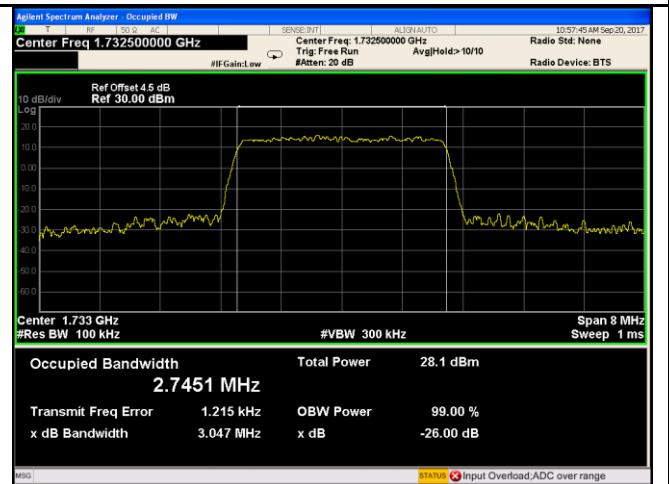

LTE band IV - Middle CH 16QAM-3

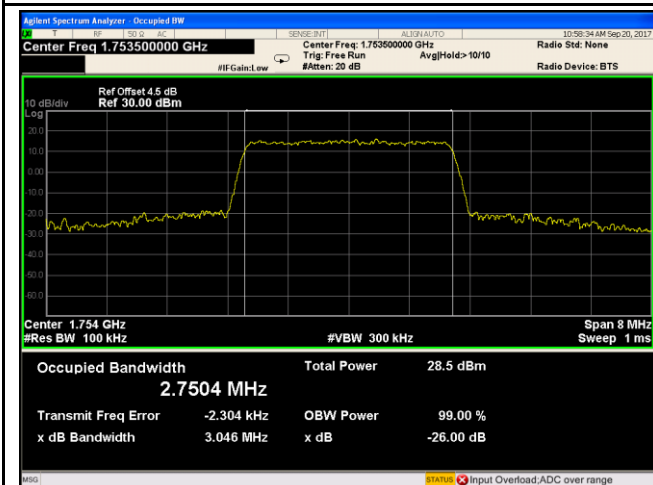

LTE band IV - High CH QPSK-3

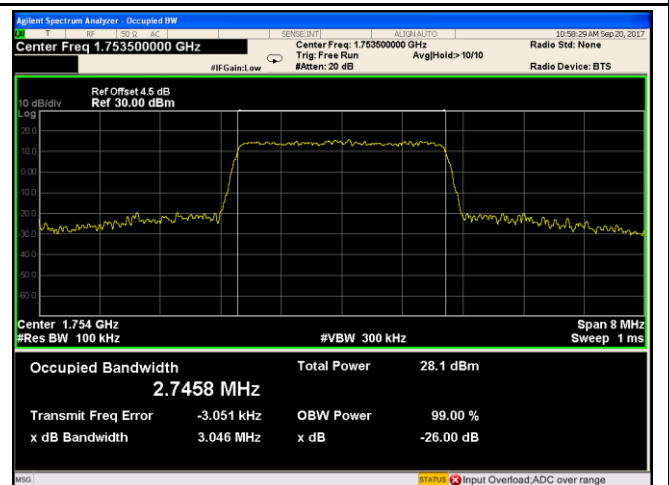

LTE band IV - High CH 16QAM-3

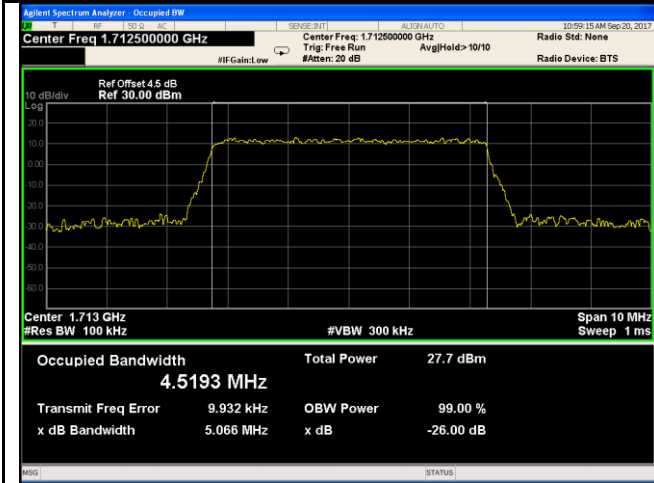

LTE band IV - Low CH QPSK-5

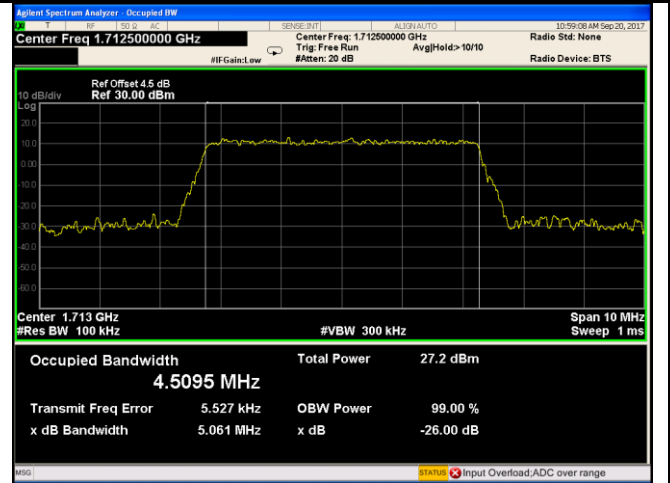

LTE band IV - Low CH 16QAM-5

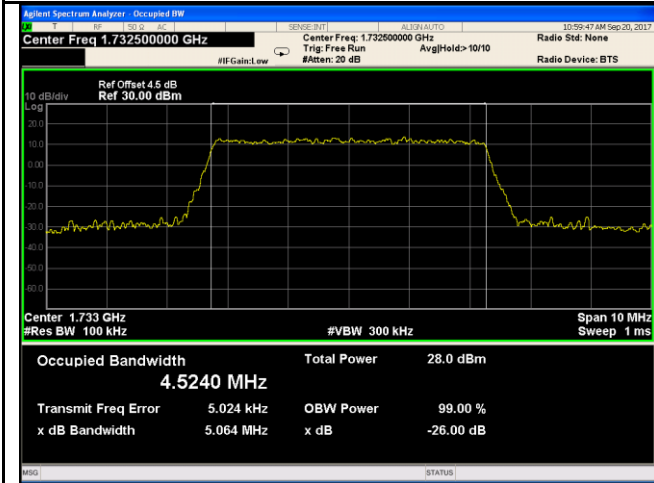

LTE band IV - Middle CH QPSK-5

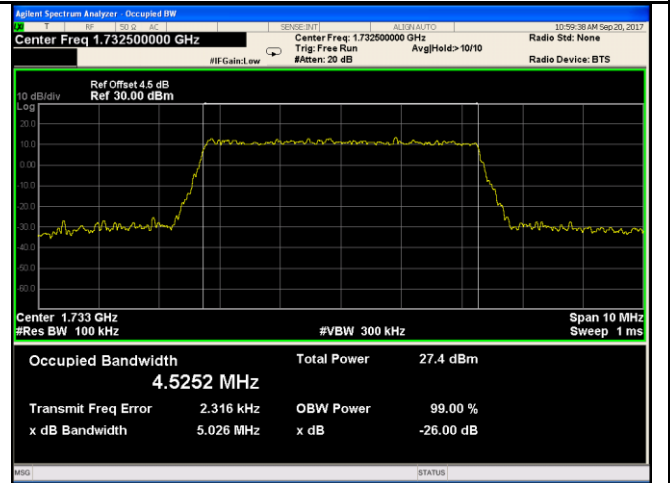

LTE band IV - Middle CH 16QAM-5

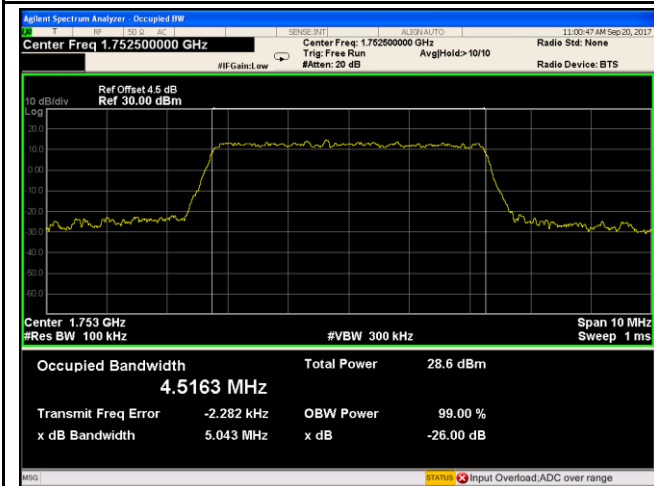

LTE band IV - High CH QPSK-5

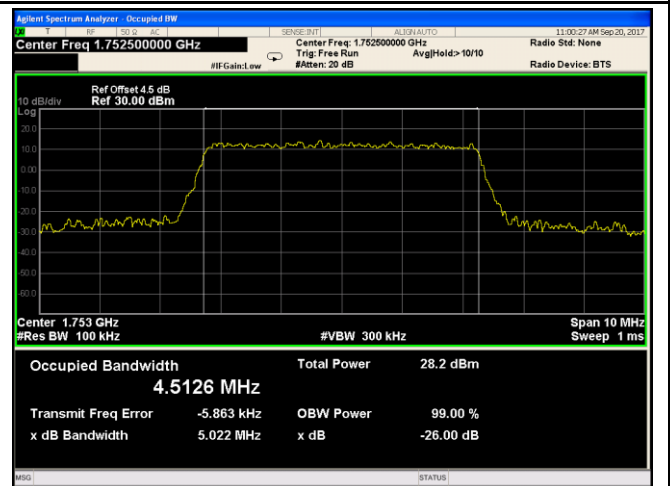

LTE band IV - High CH 16QAM-5

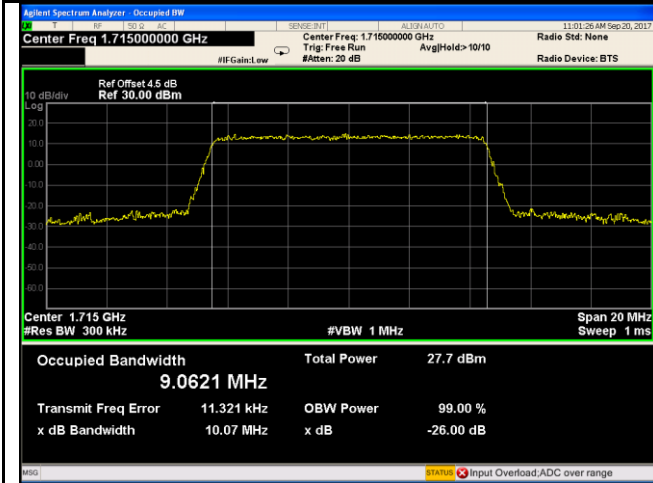

LTE band IV - Low CH QPSK-10

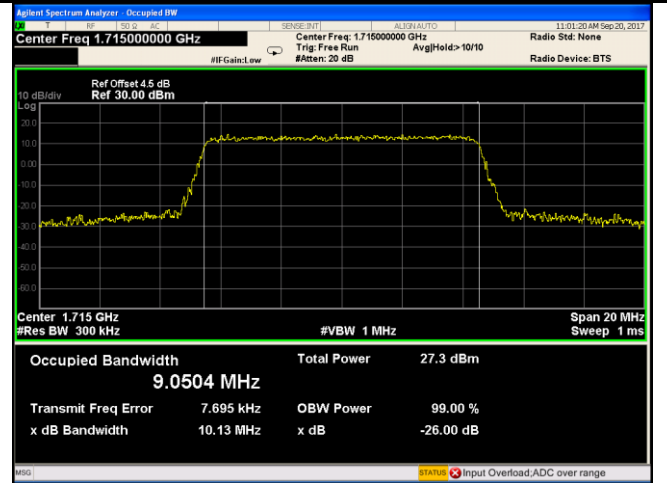

LTE band IV - Low CH 16QAM-10

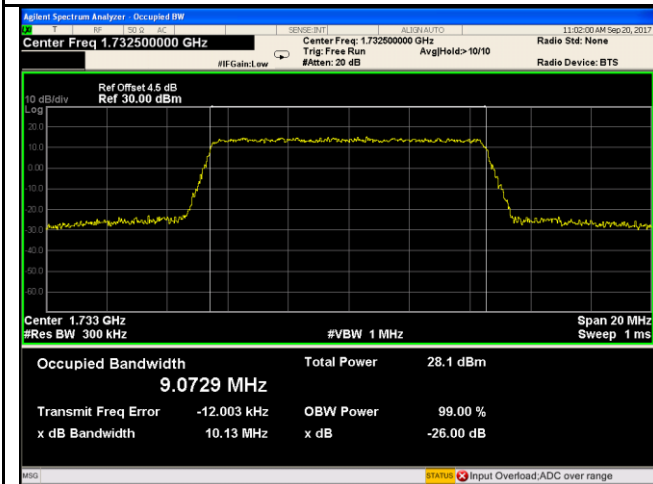

LTE band IV - Middle CH QPSK-10

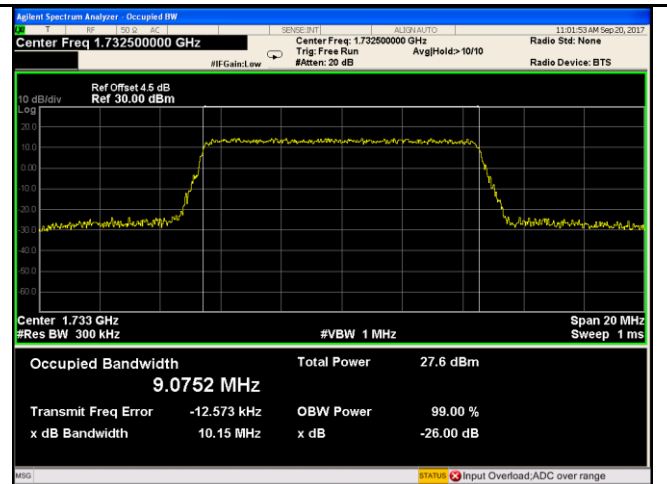

LTE band IV - Middle CH 16QAM-10

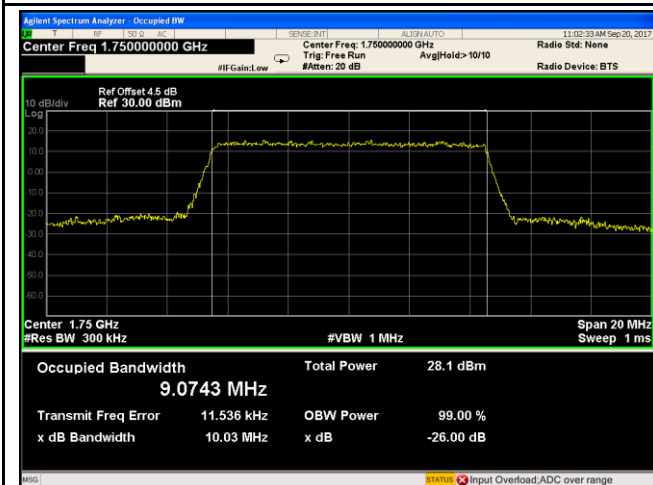

LTE band IV - High CH QPSK-10

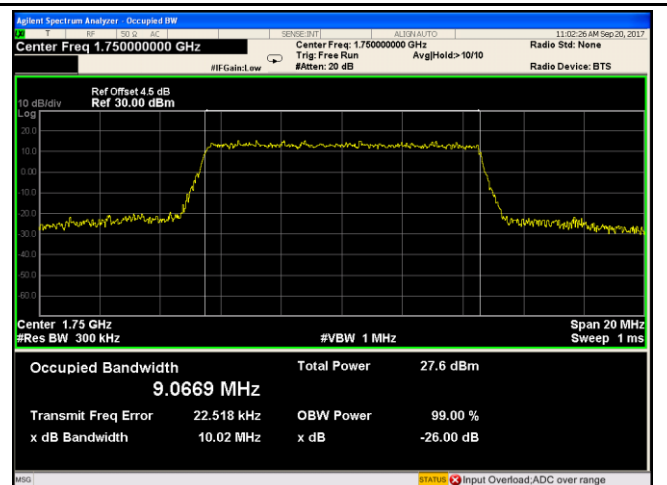

LTE band IV - High CH 16QAM-10

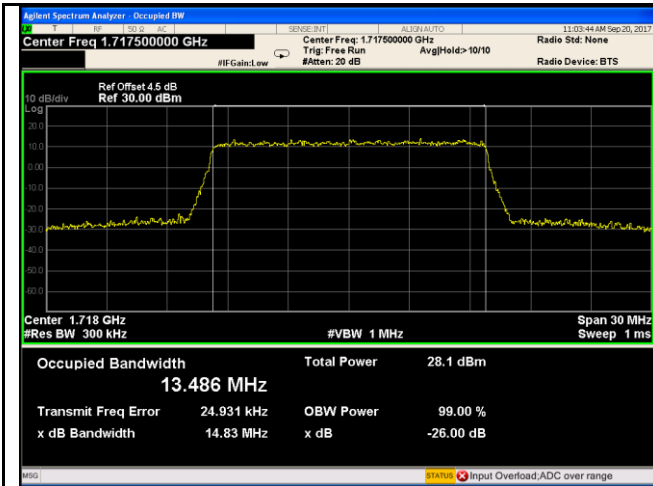

LTE band IV - Low CH QPSK-15

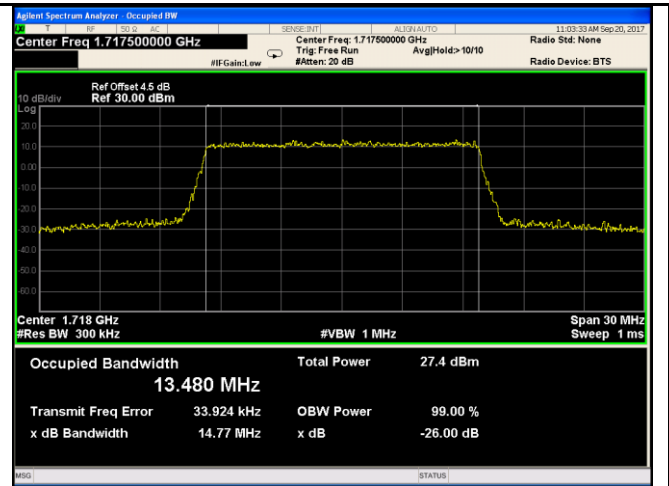

LTE band IV - Low CH 16QAM-15

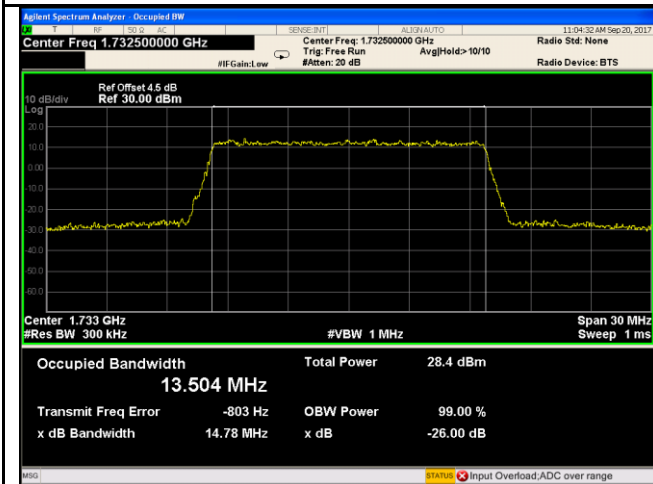

LTE band IV - Middle CH QPSK-15

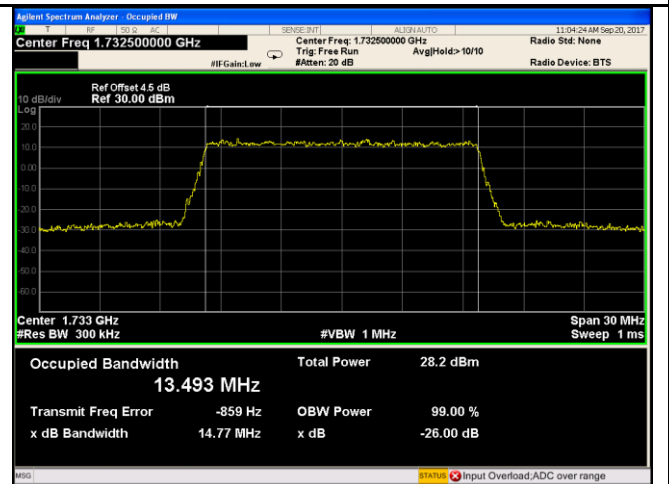

LTE band IV - Middle CH 16QAM-15

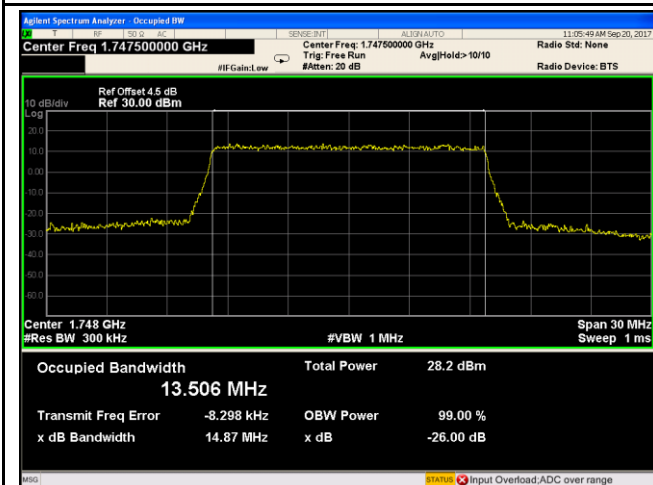

LTE band IV - High CH QPSK-15

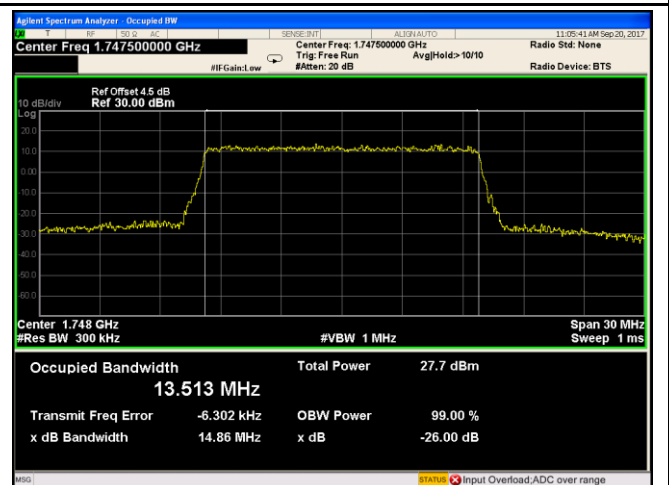

LTE band IV - High CH 16QAM-15

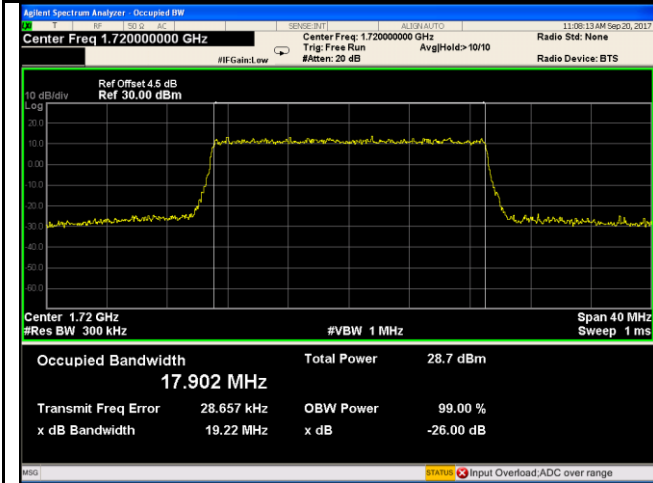

LTE band IV - Low CH QPSK-20

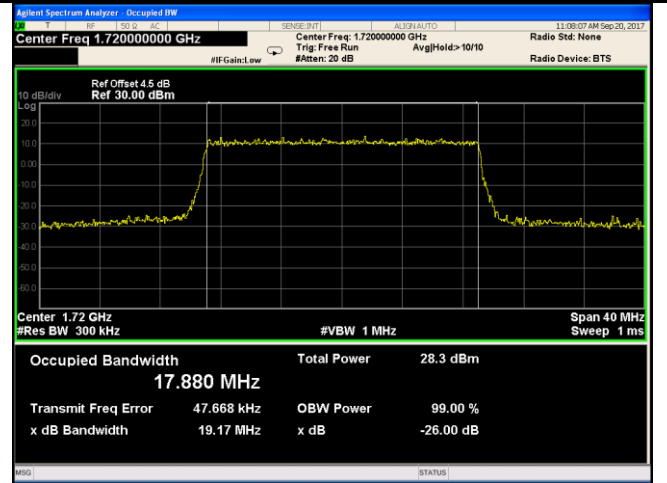

LTE band IV - Low CH 16QAM-20

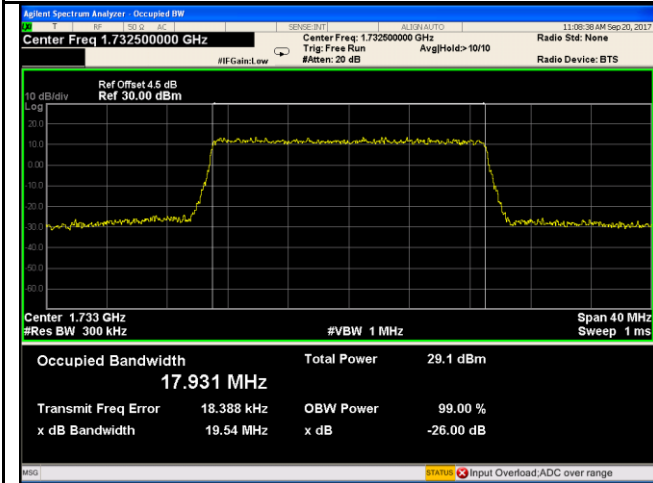

LTE band IV - Middle CH QPSK-20

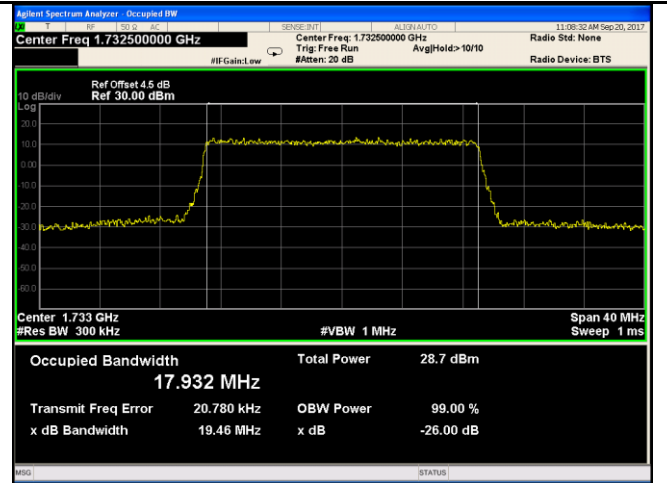

LTE band IV - Middle CH 16QAM-20

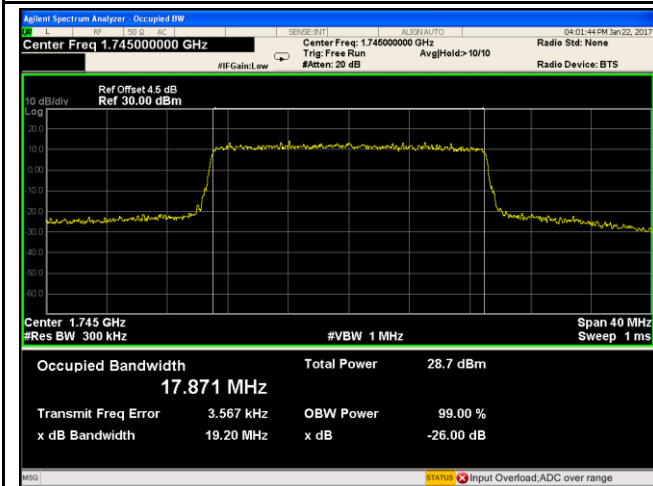

LTE band IV - High CH QPSK-20

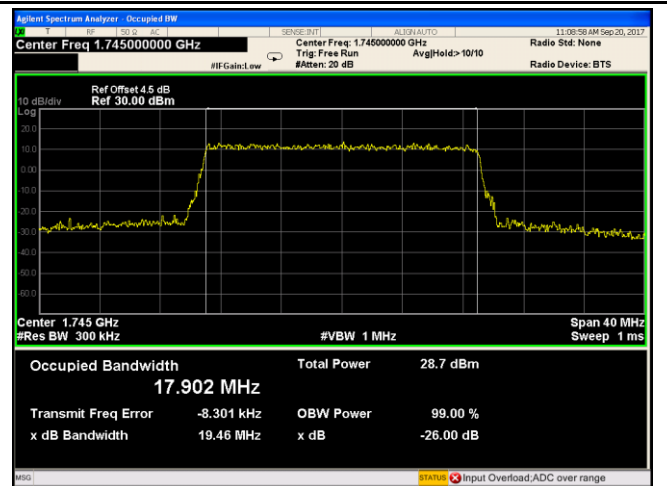

LTE band IV - High CH 16QAM-20

6.5 Spurious Emissions at Antenna Terminals

Temperature	25 °C
Relative Humidity	57%
Atmospheric Pressure	1014mbar
Test date :	September 20, 2017
Tested By :	Loren Luo

Requirement(s):

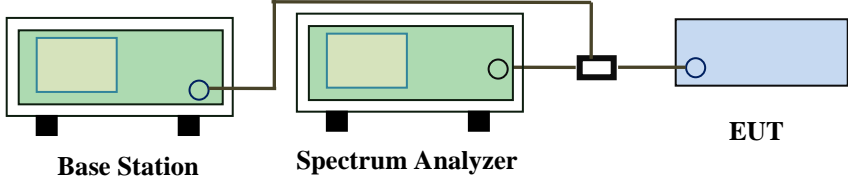
Spec	Item	Requirement	Applicable
§2.1051, § 27.53(h)	a)	The power of any emission outside of the authorized operating frequency ranges must be lower than the transmitter power (P) by a factor of at least $43 + 10 \log(P)$ dB	<input checked="" type="checkbox"/>
Test Setup	 <p style="text-align: center;">Base Station Spectrum Analyzer EUT</p>		
Test Procedure	<ul style="list-style-type: none"> - The EUT was connected to Spectrum Analyzer and Base Station via power divider. - The Band Edges of low and high channels for the highest RF powers were measured. - Setting RBW as roughly BW/100. 		
Remark			
Result	<input checked="" type="checkbox"/> Pass <input type="checkbox"/> Fail		

Test Data Yes N/A
 Test Plot Yes (See below) N/A

Test Plots 30MHz-20GHz
LTE Band IV (Part27) result

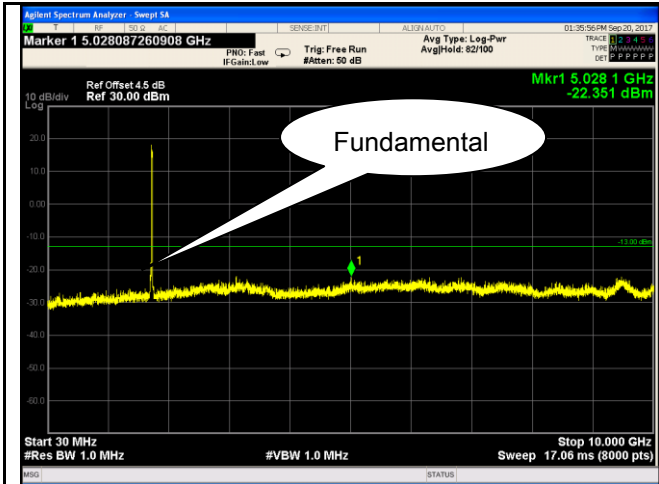

LTE Band IV - Low Channel-1

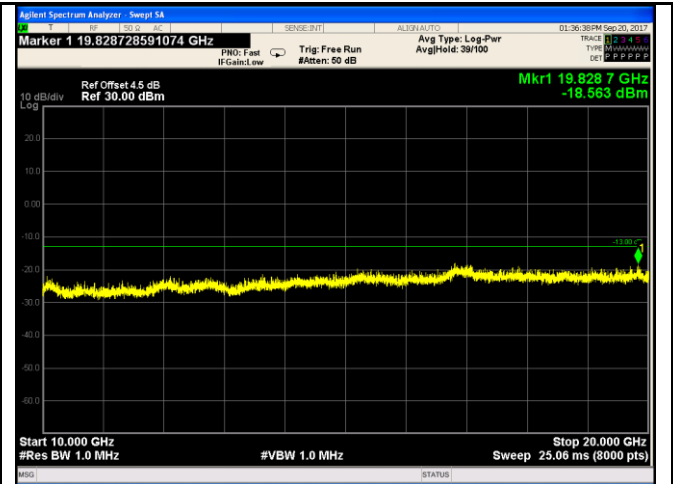

LTE Band IV - Low Channel-2

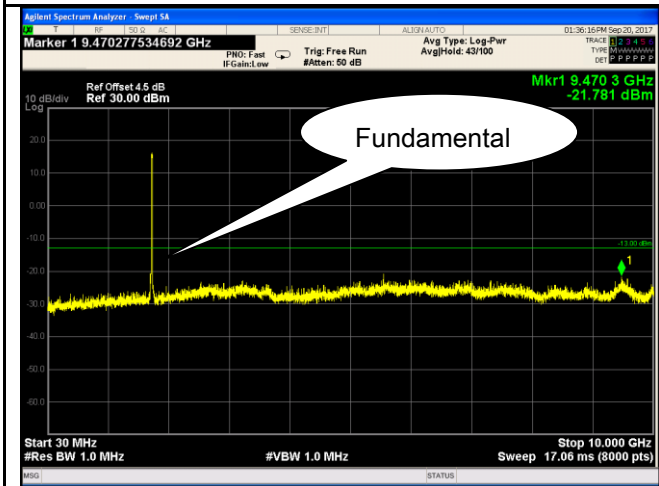

LTE Band IV - Middle Channel-1

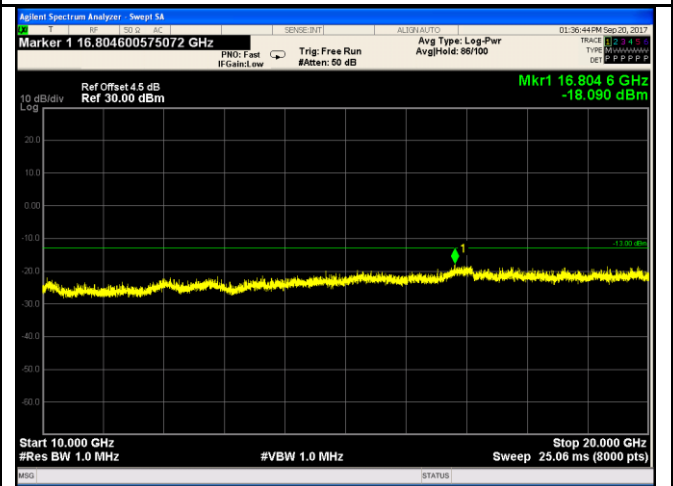

LTE Band IV - Middle Channel-2

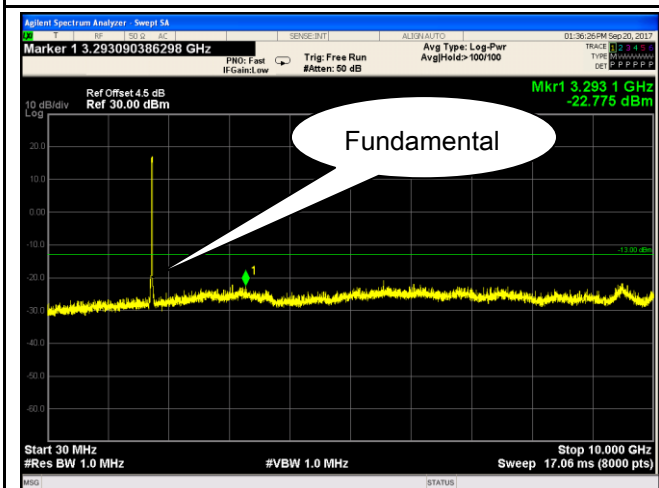

LTE Band IV - High Channel-1

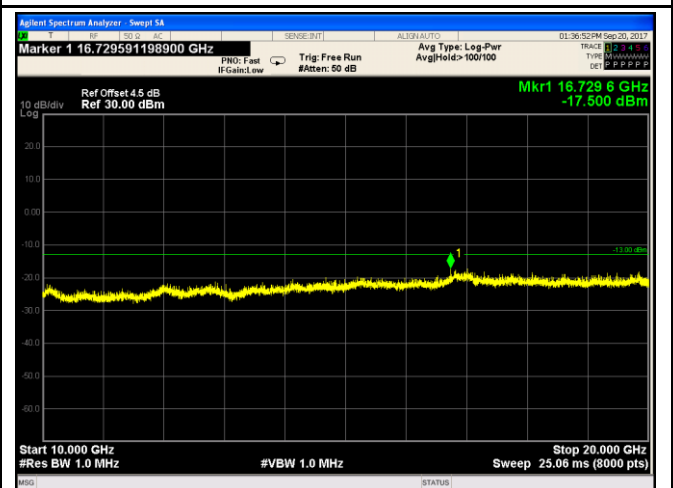

LTE Band IV - High Channel-2