



RF TEST REPORT



Report No.: 16071337-FCC-R1

Supersede Report No.: N/A

| | | |
|--|---|---|
| Applicant | MOBIWIRE MOBILES (NINGBO) CO.,LTD | |
| Product Name | Smartphone | |
| Model No. | öwn Fun Value Lite | |
| Serial No. | N/A | |
| Test Standard | FCC Part 22(H):2015 ;FCC Part 24(E):2015; ANSI/TIA-603-D: 2010 | |
| Test Date | November 21 to December 01, 2016 | |
| Issue Date | December 02, 2016 | |
| Test Result | <input checked="" type="checkbox"/> Pass <input type="checkbox"/> Fail | |
| Equipment complied with the specification | <input checked="" type="checkbox"/> | |
| Equipment did not comply with the specification | <input type="checkbox"/> | |
|  |  |  |
| Loren Luo Test Engineer | David Huang Checked By | |
| This test report may be reproduced in full only Test result presented in this test report is applicable to the tested sample only | | |

Issued by:

SIEMIC (SHENZHEN-CHINA) LABORATORIES

Zone A, Floor 1, Building 2 Wan Ye Long Technology Park

South Side of Zhoushi Road, Bao' an District, Shenzhen, Guangdong China 518108

Phone: +86 0755 2601 4629801 Email: China@siemic.com.cn

Laboratories Introduction

SIEMIC, headquartered in the heart of Silicon Valley, with superior facilities in US and Asia, is one of the leading independent testing and certification facilities providing customers with one-stop shop services for Compliance Testing and Global Certifications.



In addition to testing and certification, SIEMIC provides initial design reviews and compliance management throughout a project. Our extensive experience with China, Asia Pacific, North America, European, and International compliance requirements, assures the fastest, most cost effective way to attain regulatory compliance for the global markets.

Accreditations for Conformity Assessment

| Country/Region | Scope |
|----------------|------------------------------------|
| USA | EMC, RF/Wireless, SAR, Telecom |
| Canada | EMC, RF/Wireless, SAR, Telecom |
| Taiwan | EMC, RF, Telecom, SAR, Safety |
| Hong Kong | RF/Wireless, SAR, Telecom |
| Australia | EMC, RF, Telecom, SAR, Safety |
| Korea | EMI, EMS, RF, SAR, Telecom, Safety |
| Japan | EMI, RF/Wireless, SAR, Telecom |
| Singapore | EMC, RF, SAR, Telecom |
| Europe | EMC, RF, SAR, Telecom, Safety |

| | |
|-------------|-----------------|
| Test Report | 16071337-FCC-R1 |
| Page | 3 of 81 |

This page has been left blank intentionally.

CONTENTS

| | |
|--|----|
| 1. REPORT REVISION HISTORY | 5 |
| 2. CUSTOMER INFORMATION | 5 |
| 3. TEST SITE INFORMATION | 5 |
| 4. EQUIPMENT UNDER TEST (EUT) INFORMATION | 6 |
| 5. TEST SUMMARY | 9 |
| 6. MEASUREMENTS, EXAMINATION AND DERIVED RESULTS | 10 |
| 6.1 RF EXPOSURE (SAR)..... | 10 |
| 6.2 RF OUTPUT POWER..... | 11 |
| 6.3 PEAK-AVERAGE RATIO..... | 23 |
| 6.4 OCCUPIED BANDWIDTH..... | 26 |
| 6.5 SPURIOUS EMISSIONS AT ANTENNA TERMINALS..... | 37 |
| 6.6 SPURIOUS RADIATED EMISSIONS..... | 50 |
| 6.7 BAND EDGE..... | 56 |
| 6.8 FREQUENCY STABILITY | 66 |
| ANNEX A. TEST INSTRUMENT..... | 70 |
| ANNEX B. EUT AND TEST SETUP PHOTOGRAPHS..... | 72 |
| ANNEX C. TEST SETUP AND SUPPORTING EQUIPMENT..... | 77 |
| ANNEX C.II. EUT OPERATING CONKITIONS | 79 |
| ANNEX D. USER MANUAL / BLOCK DIAGRAM / SCHEMATICS / PARTLIST | 80 |
| ANNEX E. DECLARATION OF SIMILARITY..... | 81 |

1. Report Revision History

| Report No. | Report Version | Description | Issue Date |
|-----------------|----------------|-------------|-------------------|
| 16071337-FCC-R1 | NONE | Original | December 02, 2016 |
| | | | |
| | | | |
| | | | |
| | | | |

2. Customer information

| | |
|------------------|--|
| Applicant Name | MOBIWIRE MOBILES (NINGBO) CO.,LTD |
| Applicant Add | No.999,Dacheng East Road,Fenghua City,Zhejiang |
| Manufacturer | MOBIWIRE MOBILES (NINGBO) CO.,LTD |
| Manufacturer Add | No.999,Dacheng East Road,Fenghua City,Zhejiang |

3. Test site information

| | |
|----------------------|--|
| Lab performing tests | SIEMIC (Shenzhen-China) LABORATORIES |
| Lab Address | Zone A, Floor 1, Building 2 Wan Ye Long Technology Park South Side of Zhoushi Road, Bao' an District, Shenzhen, Guangdong China 518108 |
| FCC Test Site No. | 718246 |
| IC Test Site No. | 4842E-1 |
| Test Software | Radiated Emission Program-To Shenzhen(ICP-03A1) |

4. Equipment under Test (EUT) Information

| | |
|-------------------------------|--|
| Description of EUT: | Smartphone |
| Main Model: |  Fun Value Lite |
| Serial Model: | N/A |
| Date EUT received: | November 21, 2016 |
| Test Date(s): | November 21 to December 01, 2016 |
| Equipment Category : | PCE |
| Antenna Gain: | GSM850: -1dBi PCS1900: -1dBi UMTS-FDD Band V: -1dBi UMTS-FDD Band II: -1dBi Bluetooth/WIFI/BLE: -2dBi |
| Antenna Type: | PIFA antenna |
| Type of Modulation: | GSM / GPRS: GMSK EGPRS: GMSK,8PSK UMTS-FDD: QPSK 802.11b/g/n: DSSS, OFDM Bluetooth: GFSK, π /4DQPSK, 8DPSK BLE: GFSK |
| RF Operating Frequency (ies): | GSM850 TX: 824.2 ~ 848.8 MHz; RX: 869.2 ~ 893.8 MHz PCS1900 TX: 1850.2 ~ 1909.8 MHz; RX: 1930.2 ~ 1989.8 MHz UMTS-FDD Band V TX: 826.4 ~ 846.6 MHz; RX: 871.4 ~ 891.6 MHz UMTS-FDD Band II TX: 1852.4 ~ 1907.6 MHz; RX: 1932.4 ~ 1987.6 MHz WIFI: 802.11b/g/n(20M): 2412-2462 MHz WIFI: 802.11n(40M): 2422-2452 MHz Bluetooth& BLE: 2402-2480 MHz |

| | |
|----------------------|--|
| | GSM Voce:GSM850: 32.10 dBm |
| | PCS1900: 29.99 dBm |
| | GPRS:GSM850: 31.90 dBm |
| | PCS1900: 29.89dBm |
| | EGPRS(MCS5):GSM850: 25.29dBm |
| Maximum Conducted | PCS1900: 23.46 dBm |
| AV Power to Antenna: | RMC:UMTS-FDD Band 5: 22.71 dBm |
| | UMTS-FDD Band 2: 21.86 dBm |
| | HSUPA:UMTS-FDD Band 5: 20.71dBm |
| | UMTS-FDD Band 2: 20.83dBm |
| | HSDPA:UMTS-FDD Band 5: 20.72dBm |
| | UMTS-FDD Band 2: 20.49 dBm |
| | GSM Voce:GSM850: 29.01dBm / ERP |
| | PCS1900: 29.06 dBm / EIRP |
| | GPRS:GSM850: 28.88dBm / ERP |
| | PCS1900: 29.04 dBm / EIRP |
| | EGPRS(MCS5):GSM850: 22.38 dBm / ERP |
| ERP/EIRP: | PCS1900: 22.49dBm / EIRP |
| | RMC:UMTS-FDD Band 5: 21.78 dBm / ERP |
| | UMTS-FDD Band 2: 20.87 dBm / EIRP |
| | HSDPA:UMTS-FDD Band 5: 19.75 dBm / ERP |
| | UMTS-FDD Band 2: 19.46 dBm / EIRP |
| | HSUPA:UMTS-FDD Band 5: 19.75 dBm / ERP |
| | UMTS-FDD Band 2: 19.49 dBm / EIRP |
| | GSM 850: 124CH |
| | PCS1900: 299CH |
| | UMTS-FDD Band V: 102CH |
| Number of Channels: | UMTS-FDD Band II: 277CH |
| | WIFI :802.11b/g/n(20M): 11CH |
| | WIFI :802.11n(40M): 7CH |
| | Bluetooth: 79CH |
| | BLE: 40CH |

Port: USB Port, Earphone Port

Adapter:

Model: **öwn** Fun Value Lite

Input: AC100-240V~50/60Hz,0.15A

Output: DC 5.0V-550mA

Input Power:

Battery:

Model: **öwn** Fun Value Lite

Spec : 3.7V,1400mAh,5.18Wh

Maximum chargeable voltage: 4.2V

Trade Name :

öwn

GPRS/ EGPRS Multi-slot class 8/10/12

FCC ID: 2ADA4FUNVALUEL

5. Test Summary

The product was tested in accordance with the following specifications.

All testing has been performed according to below product classification:

| FCC Rules | Description of Test | Result |
|---|--|------------|
| § 1.1307; § 2.1093 | RF Exposure (SAR) | Compliance |
| §2.1046; § 22.913(a); § 24.232(c); § 27.50(c.10) ; | RF Output Power | Compliance |
| § 24.232 (d) ; | Peak-Average Ratio | Compliance |
| § 2.1049; § 22.905; § 22.917; § 24.238; | 99% & -26 dB Occupied Bandwidth | Compliance |
| § 2.1051; § 22.917(a); § 24.238(a); | Spurious Emissions at Antenna Terminal | Compliance |
| § 2.1053; § 22.917(a); § 24.238(a); | Field Strength of Spurious Radiation | Compliance |
| § 22.917(a); § 24.238(a); | Out of band emission, Band Edge | Compliance |
| § 2.1055; § 22.355; § 24.235; | Frequency stability vs. temperature Frequency stability vs. voltage | Compliance |

Note: Testing was performed by configuring EUT to maximum output power status, the declared output power class for different

Measurement Uncertainty

| Emissions | | |
|--|---|---------------|
| Test Item | Description | Uncertainty |
| Band Edge and Radiated Spurious Emissions | Confidence level of approximately 95% (in the case where distributions are normal), with a coverage factor of 2 (for EUTs < 0.5m X 0.5m X 0.5m) | +5.6dB/-4.5dB |
| - | - | - |

6. MEASUREMENTS, EXAMINATION AND DERIVED RESULTS

6.1 RF Exposure (SAR)

Test Result: Pass

The EUT is a portable device, thus requires SAR evaluation;

Please refer to RF Exposure Evaluation Report: 16071337-FCC-H.

6.2 RF Output Power

| | |
|----------------------|-------------------|
| Temperature | 25°C |
| Relative Humidity | 52% |
| Atmospheric Pressure | 1028mbar |
| Test date : | November 28, 2016 |
| Tested By : | Loren Luo |

Requirement(s):

| Spec | Item | Requirement | Applicable |
|-------------|------|--------------|-------------------------------------|
| §22.913 (a) | a) | ERP:38.45dBm | <input checked="" type="checkbox"/> |
| §24.232 (c) | b) | EIRP:33dBm | <input checked="" type="checkbox"/> |

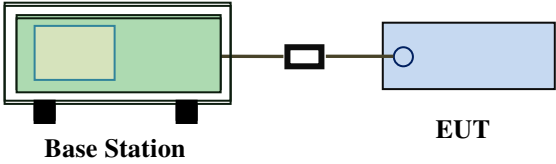
| | |
|------------|--|
| Test Setup |  <p style="text-align: center;">Base Station EUT</p> |
|------------|--|

| | |
|----------------|---|
| Test Procedure | <p>For Conducted Power:</p> <ul style="list-style-type: none"> - The transmitter output port was connected to base station. - Set EUT at maximum power through base station. - Select lowest, middle, and highest channels for each band and different test mode. <p>For ERP/EIRP:</p> <p>According with KDB 971168 v02r02</p> <ul style="list-style-type: none"> - The transmitter was placed on a wooden turntable, and it was transmitting into a non-radiating load which was also placed on the turntable. - The measurement antenna was placed at a distance of 3 meters from the EUT. During the tests, the antenna height and polarization as well as EUT azimuth were varied in order to identify the maximum level of emissions from the EUT. The test was performed by placing the EUT on 3-orthogonal axis. - The frequency range up to tenth harmonic of the fundamental frequency was investigated. |
|----------------|---|

| | |
|-------------|-----------------|
| Test Report | 16071337-FCC-R1 |
| Page | 12 of 81 |

| | |
|--------|--|
| | <ul style="list-style-type: none"> - Remove the EUT and replace it with substitution antenna. A signal generator was connected to the substitution antenna by a non-radiating cable. The absolute levels of the spurious emissions were measured by the substitution. - Spurious emissions in dB = 10 log (TX power in Watts/0.001) – the absolute level - Spurious attenuation limit in dB = 43 + 10 Log10 (power out in Watts). |
| Remark | |
| Result | <input checked="" type="checkbox"/> Pass <input type="checkbox"/> Fail |

Test Data Yes N/A
 Test Plot Yes (See below) N/A

Conducted Power

GSM Mode:

| Burst Average Power (dBm); | | | | | | | | |
|--|--------|-------|--------------|------------------------------|---------|-------|--------------|------------------------------|
| Band | GSM850 | | | | PCS1900 | | | |
| Channel | 128 | 190 | 251 | Tune up Power tolerant | 512 | 661 | 810 | Tune up Power tolerant |
| Frequency (MHz) | 824.2 | 836.6 | 848.8 | / | 1850.2 | 1880 | 1909.8 | / |
| GSM Voice (1 uplink),GMSK | 31.91 | 31.93 | 32.10 | 32±1 | 29.90 | 29.95 | 29.99 | 29.5±1 |
| GPRS Multi-Slot Class 8 (1 uplink),GMSK | 31.90 | 31.87 | 31.90 | 31.5±1 | 29.83 | 29.84 | 29.89 | 29.5±1 |
| GPRS Multi-Slot Class 10 (2 uplink) GMSK | 30.92 | 30.85 | 30.88 | 30.5±1 | 28.84 | 28.81 | 28.83 | 28.5±1 |
| GPRS Multi-Slot Class 12 (4 uplink) GMSK | 27.56 | 27.54 | 27.58 | 27.5±1 | 24.86 | 24.89 | 24.86 | 24.5±1 |
| EGPRS Multi-Slot Class 8 (1 uplink) GMSK MCS1 | 31.51 | 31.52 | 31.54 | 31.5±1 | 29.52 | 29.51 | 29.53 | 29.5±1 |
| EGPRS Multi-Slot Class 10 (2 uplink) GMSK MCS1 | 30.49 | 30.46 | 30.42 | 30±1 | 28.47 | 28.43 | 28.42 | 28.5±1 |
| EGPRS Multi-Slot Class 12 (4 uplink) GMSK MCS1 | 27.45 | 27.43 | 27.49 | 27±1 | 24.45 | 24.41 | 24.42 | 24±1 |
| EGPRS Multi-Slot Class 8 (1 uplink) 8PSK MCS5 | 25.26 | 25.23 | 25.29 | 25±1 | 23.41 | 23.43 | 23.46 | 23±1 |
| EGPRS Multi-Slot Class 10 (2 uplink) 8PSK MCS5 | 25.11 | 25.14 | 25.16 | 25±1 | 23.21 | 23.20 | 23.24 | 23±1 |
| EGPRS Multi-Slot Class 12 (4 uplink) 8PSK MCS5 | 24.16 | 24.19 | 24.18 | 24±1 | 22.26 | 22.29 | 22.28 | 22±1 |

| | |
|-------------|-----------------|
| Test Report | 16071337-FCC-R1 |
| Page | 14 of 81 |

Remark :

GPRS, CS1 coding scheme.

EGPRS, MCS1 coding scheme.

EGPRS, MCS5 coding scheme.

Multi-Slot Class 8 , Support Max 4 downlink, 1 uplink , 5 working link

Multi-Slot Class 10 , Support Max 4 downlink, 2 uplink , 5 working link

Multi-Slot Class 12 , Support Max 4 downlink, 4 uplink , 5 working link

UMTS Mode:

UMTS-FDD Band V

| Band/ Time Slot configuration | Channel | Frequency | Average power (dBm) | Tune up Power tolerant |
|-------------------------------|---------|-----------|---------------------|------------------------|
| RMC 12.2kbps | 4132 | 826.4 | 22.58 | 22±1 |
| | 4175 | 835 | 22.71 | 22±1 |
| | 4233 | 846.6 | 22.51 | 22±1 |
| HSDPA Subtest1 | 4132 | 826.4 | 20.36 | 21.3±1 |
| | 4175 | 835 | 20.56 | 21.3±1 |
| | 4233 | 846.6 | 20.54 | 21.3±1 |
| HSDPA Subtest2 | 4132 | 826.4 | 20.59 | 21.3±1 |
| | 4175 | 835 | 20.64 | 21.3±1 |
| | 4233 | 846.6 | 20.71 | 21.3±1 |
| HSDPA Subtest3 | 4132 | 826.4 | 20.39 | 21.3±1 |
| | 4175 | 835 | 20.45 | 21.3±1 |
| | 4233 | 846.6 | 20.53 | 21.3±1 |
| HSDPA Subtest4 | 4132 | 826.4 | 20.51 | 21.3±1 |
| | 4175 | 835 | 20.46 | 21.3±1 |
| | 4233 | 846.6 | 20.56 | 21.3±1 |
| HSUPA Subtest1 | 4132 | 826.4 | 20.63 | 21.3±1 |
| | 4175 | 835 | 20.69 | 21.3±1 |
| | 4233 | 846.6 | 20.66 | 21.3±1 |
| HSUPA Subtest2 | 4132 | 826.4 | 20.61 | 21.3±1 |
| | 4175 | 835 | 20.62 | 21.3±1 |
| | 4233 | 846.6 | 20.66 | 21.3±1 |
| HSUPA Subtest3 | 4132 | 826.4 | 20.59 | 21.3±1 |
| | 4175 | 835 | 20.53 | 21.3±1 |
| | 4233 | 846.6 | 20.48 | 21.3±1 |
| HSUPA Subtest4 | 4132 | 826.4 | 20.71 | 21.3±1 |
| | 4175 | 835 | 20.72 | 21.3±1 |
| | 4233 | 846.6 | 20.33 | 21.3±1 |
| HSUPA Subtest5 | 4132 | 826.4 | 20.53 | 21.3±1 |
| | 4175 | 835 | 20.55 | 21.3±1 |
| | 4233 | 846.6 | 20.51 | 21.3±1 |

UMTS-FDD Band II

| Band/ Time Slot configuration | Channel | Frequency | Average power (dBm) | Tune up Power tolerant |
|-------------------------------|---------|-----------|---------------------|------------------------|
| RMC 12.2kbps | 9262 | 1852.4 | 21.09 | 21.3±1 |
| | 9400 | 1880 | 21.86 | 21.3±1 |
| | 9538 | 1907.6 | 21.06 | 21.3±1 |
| HSDPA Subtest1 | 9262 | 1852.4 | 20.36 | 21.3±1 |
| | 9400 | 1880 | 20.39 | 21.3±1 |
| | 9538 | 1907.6 | 20.34 | 21.3±1 |
| HSDPA Subtest2 | 9262 | 1852.4 | 20.56 | 21.3±1 |
| | 9400 | 1880 | 20.49 | 21.3±1 |
| | 9538 | 1907.6 | 20.47 | 21.3±1 |
| HSDPA Subtest3 | 9262 | 1852.4 | 20.83 | 21.3±1 |
| | 9400 | 1880 | 20.15 | 21.3±1 |
| | 9538 | 1907.6 | 20.36 | 21.3±1 |
| HSDPA Subtest4 | 9262 | 1852.4 | 20.39 | 21.3±1 |
| | 9400 | 1880 | 20.34 | 21.3±1 |
| | 9538 | 1907.6 | 20.37 | 21.3±1 |
| HSUPA Subtest1 | 9262 | 1852.4 | 20.33 | 21.3±1 |
| | 9400 | 1880 | 20.45 | 21.3±1 |
| | 9538 | 1907.6 | 20.46 | 21.3±1 |
| HSUPA Subtest2 | 9262 | 1852.4 | 20.41 | 21.3±1 |
| | 9400 | 1880 | 20.43 | 21.3±1 |
| | 9538 | 1907.6 | 20.47 | 21.3±1 |
| HSUPA Subtest3 | 9262 | 1852.4 | 20.49 | 21.3±1 |
| | 9400 | 1880 | 20.44 | 21.3±1 |
| | 9538 | 1907.6 | 20.42 | 21.3±1 |
| HSUPA Subtest4 | 9262 | 1852.4 | 20.40 | 21.3±1 |
| | 9400 | 1880 | 20.44 | 21.3±1 |
| | 9538 | 1907.6 | 20.46 | 21.3±1 |
| HSUPA Subtest5 | 9262 | 1852.4 | 20.49 | 21.3±1 |
| | 9400 | 1880 | 20.41 | 21.3±1 |
| | 9538 | 1907.6 | 20.42 | 21.3±1 |

ERP & EIRP

GSM Voice

ERP for Cellular Band (Part 22H)

| Frequency (MHz) | Substituted level (dBm) | Antenna Polarization | Antenna Gain correction (dBi) | Cable Loss (dB) | Absolute Level (dBm) | Limit (dBm) |
|-----------------|-------------------------|----------------------|-------------------------------|-----------------|----------------------|-------------|
| 824.2 | 22.43 | V | 6.8 | 0.53 | 28.70 | 38.45 |
| 824.2 | 20.74 | H | 6.8 | 0.53 | 27.01 | 38.45 |
| 836.6 | 22.45 | V | 6.8 | 0.53 | 28.72 | 38.45 |
| 836.6 | 20.76 | H | 6.8 | 0.53 | 27.03 | 38.45 |
| 848.8 | 22.64 | V | 6.9 | 0.53 | 29.01 | 38.45 |
| 848.8 | 20.95 | H | 6.9 | 0.53 | 27.32 | 38.45 |

EIRP for PCS Band (Part 24E)

| Frequency (MHz) | Substituted level (dBm) | Antenna Polarization | Antenna Gain correction (dBi) | Cable Loss (dB) | Absolute Level (dBm) | Limit (dBm) |
|-----------------|-------------------------|----------------------|-------------------------------|-----------------|----------------------|-------------|
| 1850.2 | 22.03 | V | 7.88 | 0.85 | 29.06 | 33 |
| 1850.2 | 20.54 | H | 7.88 | 0.85 | 27.57 | 33 |
| 1880 | 21.96 | V | 7.88 | 0.85 | 28.99 | 33 |
| 1880 | 20.43 | H | 7.88 | 0.85 | 27.46 | 33 |
| 1909.8 | 21.89 | V | 7.86 | 0.85 | 28.90 | 33 |
| 1909.8 | 20.35 | H | 7.86 | 0.85 | 27.36 | 33 |

GPRS:

ERP for Cellular Band (Part 22H)

| Frequency (MHz) | Substituted level (dBm) | Antenna Polarization | Antenna Gain correction (dBi) | Cable Loss (dB) | Absolute Level (dBm) | Limit (dBm) |
|-----------------|-------------------------|----------------------|-------------------------------|-----------------|----------------------|-------------|
| 824.2 | 22.46 | V | 6.8 | 0.53 | 28.73 | 38.45 |
| 824.2 | 20.77 | H | 6.8 | 0.53 | 27.04 | 38.45 |
| 836.6 | 22.41 | V | 6.8 | 0.53 | 28.68 | 38.45 |
| 836.6 | 20.72 | H | 6.8 | 0.53 | 26.99 | 38.45 |
| 848.8 | 22.51 | V | 6.9 | 0.53 | 28.88 | 38.45 |
| 848.8 | 20.82 | H | 6.9 | 0.53 | 27.19 | 38.45 |

EIRP for PCS Band (Part 24E)

| Frequency (MHz) | Substituted level (dBm) | Antenna Polarization | Antenna Gain correction (dBi) | Cable Loss (dB) | Absolute Level (dBm) | Limit (dBm) |
|-----------------|-------------------------|----------------------|-------------------------------|-----------------|----------------------|-------------|
| 1850.2 | 22.01 | V | 7.88 | 0.85 | 29.04 | 33 |
| 1850.2 | 20.52 | H | 7.88 | 0.85 | 27.55 | 33 |
| 1880 | 21.94 | V | 7.88 | 0.85 | 28.97 | 33 |
| 1880 | 20.41 | H | 7.88 | 0.85 | 27.44 | 33 |
| 1909.8 | 21.85 | V | 7.86 | 0.85 | 28.86 | 33 |
| 1909.8 | 20.33 | H | 7.86 | 0.85 | 27.34 | 33 |

EGPRS (MCS5):

ERP for Cellular Band (Part 22H)

| Frequency (MHz) | Substituted level (dBm) | Antenna Polarization | Antenna Gain correction (dBi) | Cable Loss (dB) | Absolute Level (dBm) | Limit (dBm) |
|-----------------|-------------------------|----------------------|-------------------------------|-----------------|----------------------|-------------|
| 824.2 | 15.98 | V | 6.8 | 0.53 | 22.25 | 38.45 |
| 824.2 | 14.35 | H | 6.8 | 0.53 | 20.62 | 38.45 |
| 836.6 | 15.87 | V | 6.8 | 0.53 | 22.14 | 38.45 |
| 836.6 | 14.26 | H | 6.8 | 0.53 | 20.53 | 38.45 |
| 848.8 | 16.01 | V | 6.9 | 0.53 | 22.38 | 38.45 |
| 848.8 | 14.38 | H | 6.9 | 0.53 | 20.75 | 38.45 |

EIRP for PCS Band (Part 24E)

| Frequency (MHz) | Substituted level (dBm) | Antenna Polarization | Antenna Gain correction (dBi) | Cable Loss (dB) | Absolute Level (dBm) | Limit (dBm) |
|-----------------|-------------------------|----------------------|-------------------------------|-----------------|----------------------|-------------|
| 1850.2 | 15.42 | V | 7.88 | 0.85 | 22.45 | 33 |
| 1850.2 | 13.86 | H | 7.88 | 0.85 | 20.89 | 33 |
| 1880 | 15.46 | V | 7.88 | 0.85 | 22.49 | 33 |
| 1880 | 13.91 | H | 7.88 | 0.85 | 20.94 | 33 |
| 1909.8 | 15.37 | V | 7.86 | 0.85 | 22.38 | 33 |
| 1909.8 | 13.81 | H | 7.86 | 0.85 | 20.82 | 33 |

RMC

ERP for UMTS-FDD Band V (Part 22H)

| Frequency (MHz) | Substituted level (dBm) | Antenna Polarization | Antenna Gain correction (dBi) | Cable Loss (dB) | Absolute Level (dBm) | Limit (dBm) |
|-----------------|-------------------------|----------------------|-------------------------------|-----------------|----------------------|-------------|
| 826.4 | 15.34 | V | 6.8 | 0.53 | 21.61 | 38.45 |
| 826.4 | 14.43 | H | 6.8 | 0.53 | 20.70 | 38.45 |
| 835 | 15.28 | V | 6.8 | 0.53 | 21.55 | 38.45 |
| 835 | 14.36 | H | 6.8 | 0.53 | 20.63 | 38.45 |
| 846.6 | 15.41 | V | 6.9 | 0.53 | 21.78 | 38.45 |
| 846.6 | 14.52 | H | 6.9 | 0.53 | 20.89 | 38.45 |

EIRP for UMTS-FDD Band II (Part 24E)

| Frequency (MHz) | Substituted level (dBm) | Antenna Polarization | Antenna Gain correction (dBi) | Cable Loss (dB) | Absolute Level (dBm) | Limit (dBm) |
|-----------------|-------------------------|----------------------|-------------------------------|-----------------|----------------------|-------------|
| 1852.4 | 13.02 | V | 7.88 | 0.85 | 20.05 | 33 |
| 1852.4 | 12.14 | H | 7.88 | 0.85 | 19.17 | 33 |
| 1880 | 13.84 | V | 7.88 | 0.85 | 20.87 | 33 |
| 1880 | 12.95 | H | 7.88 | 0.85 | 19.98 | 33 |
| 1907.6 | 12.96 | V | 7.86 | 0.85 | 19.97 | 33 |
| 1907.6 | 12.05 | H | 7.86 | 0.85 | 19.06 | 33 |

HSDPA

ERP for UMTS-FDD Band V (Part 22H)

| Frequency (MHz) | Substituted level (dBm) | Antenna Polarization | Antenna Gain correction (dBi) | Cable Loss (dB) | Absolute Level (dBm) | Limit (dBm) |
|-----------------|-------------------------|----------------------|-------------------------------|-----------------|----------------------|-------------|
| 826.4 | 13.34 | V | 6.8 | 0.53 | 19.61 | 38.45 |
| 826.4 | 12.45 | H | 6.8 | 0.53 | 18.72 | 38.45 |
| 835 | 13.3 | V | 6.8 | 0.53 | 19.57 | 38.45 |
| 835 | 12.41 | H | 6.8 | 0.53 | 18.68 | 38.45 |
| 846.6 | 13.38 | V | 6.9 | 0.53 | 19.75 | 38.45 |
| 846.6 | 12.49 | H | 6.9 | 0.53 | 18.86 | 38.45 |

EIRP for UMTS-FDD Band II (Part 24E)

| Frequency (MHz) | Substituted level (dBm) | Antenna Polarization | Antenna Gain correction (dBi) | Cable Loss (dB) | Absolute Level (dBm) | Limit (dBm) |
|-----------------|-------------------------|----------------------|-------------------------------|-----------------|----------------------|-------------|
| 1852.4 | 12.38 | V | 7.88 | 0.85 | 19.41 | 33 |
| 1852.4 | 11.46 | H | 7.88 | 0.85 | 18.49 | 33 |
| 1880 | 12.43 | V | 7.88 | 0.85 | 19.46 | 33 |
| 1880 | 11.54 | H | 7.88 | 0.85 | 18.57 | 33 |
| 1907.6 | 12.35 | V | 7.86 | 0.85 | 19.36 | 33 |
| 1907.6 | 11.43 | H | 7.86 | 0.85 | 18.44 | 33 |

HSUPA

ERP for UMTS-FDD Band V (Part 22H)

| Frequency (MHz) | Substituted level (dBm) | Antenna Polarization | Antenna Gain correction (dBi) | Cable Loss (dB) | Absolute Level (dBm) | Limit (dBm) |
|-----------------|-------------------------|----------------------|-------------------------------|-----------------|----------------------|-------------|
| 826.4 | 13.33 | V | 6.8 | 0.53 | 19.60 | 38.45 |
| 826.4 | 12.45 | H | 6.8 | 0.53 | 18.72 | 38.45 |
| 835 | 13.46 | V | 6.8 | 0.53 | 19.73 | 38.45 |
| 835 | 12.54 | H | 6.8 | 0.53 | 18.81 | 38.45 |
| 846.6 | 13.38 | V | 6.9 | 0.53 | 19.75 | 38.45 |
| 846.6 | 12.49 | H | 6.9 | 0.53 | 18.86 | 38.45 |

EIRP for UMTS-FDD Band II (Part 24E)

| Frequency (MHz) | Substituted level (dBm) | Antenna Polarization | Antenna Gain correction (dBi) | Cable Loss (dB) | Absolute Level (dBm) | Limit (dBm) |
|-----------------|-------------------------|----------------------|-------------------------------|-----------------|----------------------|-------------|
| 1852.4 | 12.46 | V | 7.88 | 0.85 | 19.49 | 33 |
| 1852.4 | 11.58 | H | 7.88 | 0.85 | 18.61 | 33 |
| 1880 | 12.37 | V | 7.88 | 0.85 | 19.40 | 33 |
| 1880 | 11.43 | H | 7.88 | 0.85 | 18.46 | 33 |
| 1907.6 | 12.41 | V | 7.86 | 0.85 | 19.42 | 33 |
| 1907.6 | 11.55 | H | 7.86 | 0.85 | 18.56 | 33 |

6.3 Peak-Average Ratio

| | |
|----------------------|-------------------|
| Temperature | 25°C |
| Relative Humidity | 52% |
| Atmospheric Pressure | 1028mbar |
| Test date : | November 28, 2016 |
| Tested By : | Loren Luo |

Requirement(s):

| Spec | Item | Requirement | Applicable |
|------------|------|--|-------------------------------------|
| §24.232(d) | a) | The peak-to-average ratio (PAR) of the transmission may not exceed 13dB. | <input checked="" type="checkbox"/> |

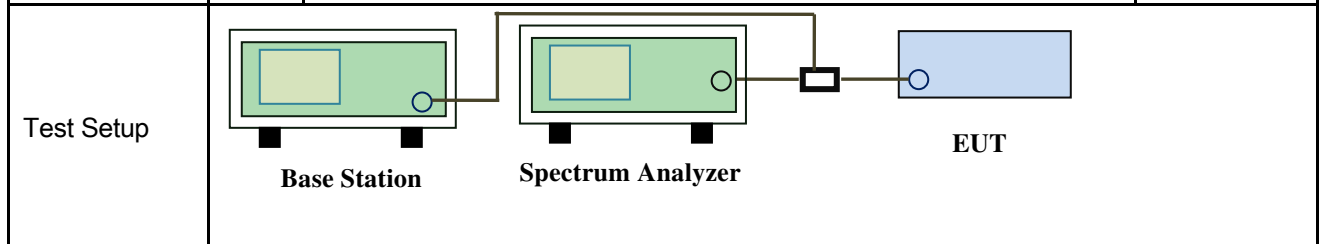

| | |
|----------------|--|
| Test Procedure | <p>According with KDB 971168 v02r02</p> <p>5.7.2 Alternate procedure for PAPR</p> <p>5.1.2 Peak power measurements with a peak power meter</p> <p>The total peak output power may be measured using a broadband peak RF power meter. The power meter must have a video bandwidth that is greater than or equal to the emission bandwidth and utilize a fast-responding diode detector.</p> <p>5.2.3 Average power measurement with average power meter</p> <p>As an alternative to the use of a spectrum/signal analyzer or EMI receiver to perform a measurement of the total in-band average output power, a wideband RF average power meter with a thermocouple detector or equivalent can be used under certain conditions</p> <p>If the EUT can be configured to transmit continuously (i.e., the burst duty cycle $\geq 98\%$) and at all times the EUT is transmitting at its maximum output</p> |
|----------------|--|

| | |
|-------------|-----------------|
| Test Report | 16071337-FCC-R1 |
| Page | 24 of 81 |

| | |
|--------|---|
| | <p>power level, then a conventional wide-band RF power meter can be used.</p> <p>If the EUT cannot be configured to transmit continuously (i.e., the burst duty cycle < 98%), then there are two options for the use of an average power meter. First, a gated average power meter can be used to perform the measurement if the gating parameters can be adjusted such that the power is measured only over active transmission bursts at maximum output power levels. A conventional average power meter can also be used if the measured burst duty cycle is constant (i.e., duty cycle variations are less than ± 2 percent) by performing the measurement over the on/off burst cycles and then correcting (increasing) the measured level by a factor equal to $10\log(1/\text{duty cycle})$</p> |
| Remark | |
| Result | <input checked="" type="checkbox"/> Pass <input type="checkbox"/> Fail |

Test Data Yes N/A
Test Plot Yes (See below) N/A

GSM : GSM 1900 PK-AV POWER (PART 24E)

| Frequency (MHz) | Conducted power(dBm) | | Peak-Average Ratio(PAR) |
|--------------------|----------------------|---------|----------------------------|
| | Peak | Average | |
| 1850.2 | 32.87 | 31.91 | 0.96 |
| 1880 | 32.95 | 31.93 | 1.02 |
| 1909.8 | 33.14 | 32.10 | 1.04 |

GPRS 1900 PK-AV POWER (PART 24E)

| Frequency (MHz) | Conducted power(dBm) | | Peak-Average Ratio(PAR) |
|--------------------|----------------------|---------|----------------------------|
| | Peak | Average | |
| 1850.2 | 32.95 | 31.90 | 1.05 |
| 1880 | 32.91 | 31.87 | 1.04 |
| 1909.8 | 32.93 | 31.90 | 1.03 |

RMC : UMTS-FDD Band 2 PK-AV POWER (PART 24E)

| Frequency (MHz) | Conducted power(dBm) | | Peak-Average Ratio(PAR) |
|--------------------|----------------------|---------|----------------------------|
| | Peak | Average | |
| 1852.4 | 23.12 | 21.09 | 2.03 |
| 1880 | 23.91 | 21.86 | 2.05 |
| 1907.6 | 23.11 | 21.06 | 2.05 |

HSDPA : UMTS-FDD Band 2 PK-AV POWER (PART 24E)

| Frequency (MHz) | Conducted power(dBm) | | Peak-Average Ratio(PAR) |
|--------------------|----------------------|---------|----------------------------|
| | Peak | Average | |
| 1852.4 | 23.39 | 20.36 | 3.03 |
| 1880 | 23.45 | 20.39 | 3.06 |
| 1907.6 | 23.39 | 20.34 | 3.05 |

HSUPA : UMTS-FDD Band 2 PK-AV POWER (PART 24E)

| Frequency (MHz) | Conducted power(dBm) | | Peak-Average Ratio(PAR) |
|--------------------|----------------------|---------|----------------------------|
| | Peak | Average | |
| 1852.4 | 22.59 | 20.33 | 2.26 |
| 1880 | 22.41 | 20.45 | 1.96 |
| 1907.6 | 22.53 | 20.46 | 2.07 |

6.4 Occupied Bandwidth

| | |
|----------------------|-------------------|
| Temperature | 25°C |
| Relative Humidity | 52% |
| Atmospheric Pressure | 1028mbar |
| Test date : | November 28, 2016 |
| Tested By : | Loren Luo |

Requirement(s):

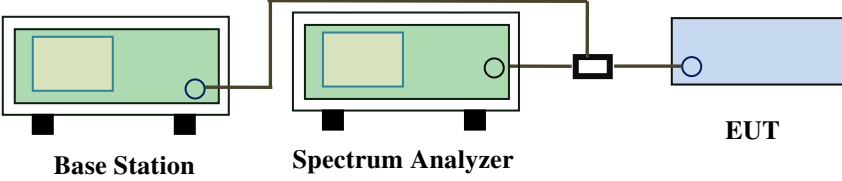
| Spec | Item | Requirement | Applicable |
|--|--|-----------------------------|-------------------------------------|
| §2.1049, §22.917, §22.905 §24.238 | a) | 99% Occupied Bandwidth(kHz) | <input checked="" type="checkbox"/> |
| | b) | 26 dB Bandwidth(kHz) | <input checked="" type="checkbox"/> |
| Test Setup |  <p>The diagram illustrates the test setup. On the left is a green box labeled 'Base Station'. A line connects it to a central green box labeled 'Spectrum Analyzer'. From the Spectrum Analyzer, a line goes to a small black box representing a power divider. From the power divider, two lines branch out: one goes back to the Base Station, and the other goes to a blue box on the right labeled 'EUT'.</p> | | |
| Test Procedure | <ul style="list-style-type: none"> - The EUT was connected to Spectrum Analyzer and Base Station via power divider. - The 99% and 26 dB occupied bandwidth (BW) of the middle channel for the highest RF powers. | | |
| Remark | | | |
| Result | <input checked="" type="checkbox"/> Pass <input type="checkbox"/> Fail | | |

Test Data Yes N/A

Test Plot Yes (See below) N/A

GSM Voice:

Cellular Band (Part 22H) result

| Channel | Frequency (MHz) | 99% Occupied Bandwidth (kHz) | 26 dB Bandwidth (kHz) |
|---------|-----------------|------------------------------|-----------------------|
| 128 | 824.2 | 250.1476 | 320.868 |
| 190 | 836.6 | 248.9109 | 316.666 |
| 251 | 848.8 | 250.6050 | 314.472 |

PCS Band (Part 24E) result

| Channel | Frequency (MHz) | 99% Occupied Bandwidth (kHz) | 26 dB Bandwidth (kHz) |
|---------|-----------------|------------------------------|-----------------------|
| 512 | 1850.2 | 246.8136 | 321.418 |
| 661 | 1880.0 | 247.6909 | 316.037 |
| 810 | 1909.8 | 249.3186 | 321.446 |

GPRS:

Cellular Band (Part 22H) result

| Channel | Frequency (MHz) | 99% Occupied Bandwidth (kHz) | 26 dB Bandwidth (kHz) |
|---------|-----------------|------------------------------|-----------------------|
| 128 | 824.2 | 246.9452 | 322.272 |
| 190 | 836.6 | 247.4075 | 317.918 |
| 251 | 848.8 | 246.6470 | 322.214 |

PCS Band (Part 24E) result

| Channel | Frequency (MHz) | 99% Occupied Bandwidth (kHz) | 26 dB Bandwidth (kHz) |
|---------|-----------------|------------------------------|-----------------------|
| 512 | 1850.2 | 247.9537 | 321.364 |
| 661 | 1880.0 | 242.7939 | 320.095 |
| 810 | 1909.8 | 248.7000 | 319.883 |

EGPRS (MCS 5):

Cellular Band (Part 22H) result

| Channel | Frequency (MHz) | 99% Occupied Bandwidth (kHz) | 26 dB Bandwidth (kHz) |
|---------|-----------------|------------------------------|-----------------------|
| 128 | 824.2 | 246.7415 | 317.249 |
| 190 | 836.6 | 247.8000 | 318.791 |
| 251 | 848.8 | 247.8826 | 318.049 |

PCS Band (Part 24E) result

| Channel | Frequency (MHz) | 99% Occupied Bandwidth (kHz) | 26 dB Bandwidth (kHz) |
|---------|-----------------|------------------------------|-----------------------|
| 512 | 1850.2 | 247.5722 | 327.365 |
| 661 | 1880.0 | 248.1934 | 326.504 |
| 810 | 1909.8 | 246.5058 | 312.025 |

RMC:

UMTS-FDD Band V (Part 22H)

| Channel | Frequency (MHz) | 99% Occupied Bandwidth (MHz) | 26 dB Bandwidth (MHz) |
|---------|-----------------|------------------------------|-----------------------|
| 4132 | 826.4 | 4.1441 | 4.704 |
| 4175 | 835.0 | 4.1538 | 4.697 |
| 4233 | 846.6 | 4.1553 | 4.703 |

UMTS-FDD Band II (Part 24E)

| Channel | Frequency (MHz) | 99% Occupied Bandwidth (MHz) | 26 dB Bandwidth (MHz) |
|---------|-----------------|------------------------------|-----------------------|
| 9262 | 1852.4 | 4.1596 | 4.709 |
| 9400 | 1880.0 | 4.1682 | 4.718 |
| 9538 | 1907.6 | 4.1624 | 4.695 |

HSDPA:

UMTS-FDD Band V (Part 22H)

| Channel | Frequency (MHz) | 99% Occupied Bandwidth (MHz) | 26 dB Bandwidth (MHz) |
|---------|-----------------|------------------------------|-----------------------|
| 4132 | 826.4 | 4.1579 | 4.690 |
| 4175 | 835.0 | 4.1615 | 4.714 |
| 4233 | 846.6 | 4.1506 | 4.707 |

UMTS-FDD Band II (Part 24E)

| Channel | Frequency (MHz) | 99% Occupied Bandwidth (MHz) | 26 dB Bandwidth (MHz) |
|---------|-----------------|------------------------------|-----------------------|
| 9262 | 1852.4 | 4.1736 | 4.707 |
| 9400 | 1880.0 | 4.1594 | 4.706 |
| 9538 | 1907.6 | 4.1691 | 4.724 |

HSUPA:

UMTS-FDD Band V (Part 22H)

| Channel | Frequency (MHz) | 99% Occupied Bandwidth (MHz) | 26 dB Bandwidth (MHz) |
|---------|-----------------|------------------------------|-----------------------|
| 4132 | 826.4 | 4.1455 | 4.675 |
| 4175 | 835.0 | 4.1659 | 4.715 |
| 4233 | 846.6 | 4.1448 | 4.704 |

UMTS-FDD Band II (Part 24E)

| Channel | Frequency (MHz) | 99% Occupied Bandwidth (MHz) | 26 dB Bandwidth (MHz) |
|---------|-----------------|------------------------------|-----------------------|
| 9262 | 1852.4 | 4.1684 | 4.743 |
| 9400 | 1880.0 | 4.1669 | 4.741 |
| 9538 | 1907.6 | 4.1598 | 4.731 |

Test Plots

GSM Voice:

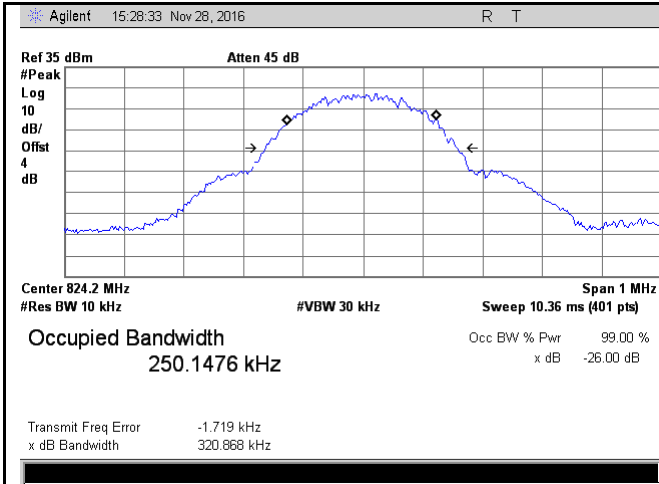

GSM 850 BW - Low CH 824.2MHz

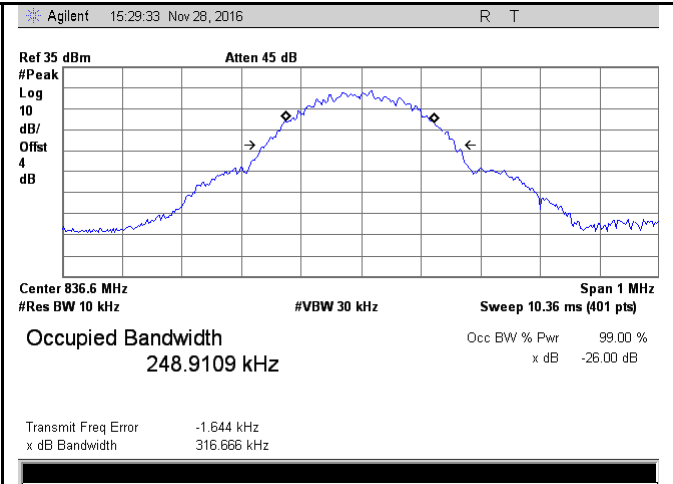

GSM 850 BW - Mid CH 836.6MHz

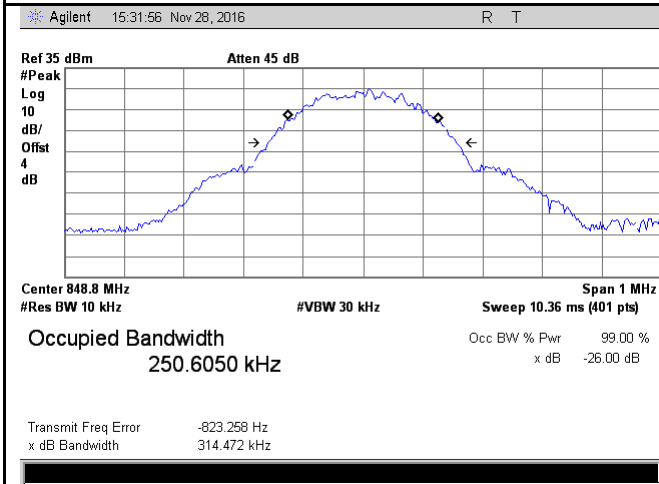

GSM 850 BW - High CH 848.8MHz

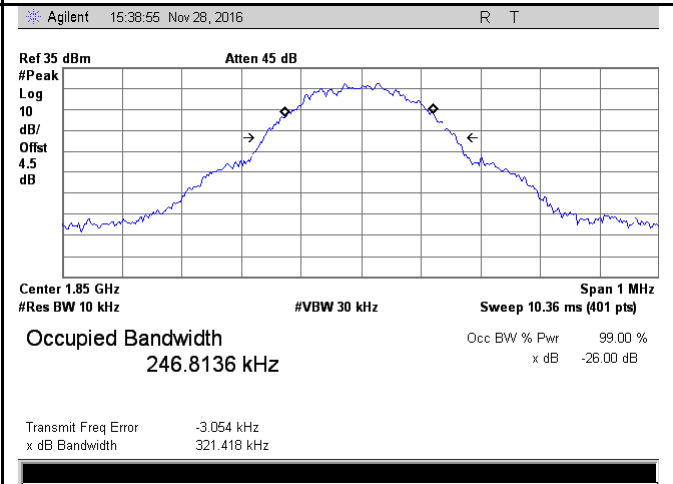

PCS 1900 BW - Low CH 1850.2MHz

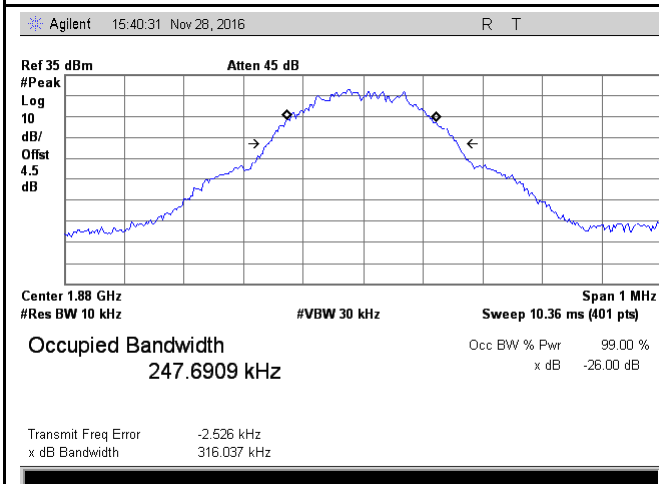

PCS 1900 BW - Mid CH 1880MHz

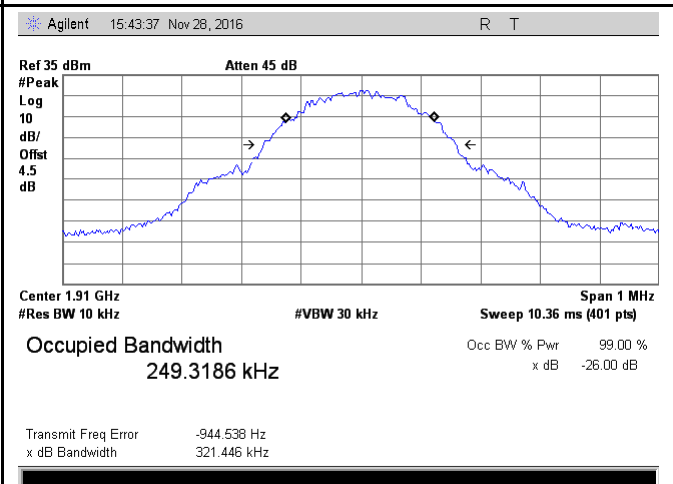

PCS 1900 BW - High CH 1909.8MHz

GPRS:

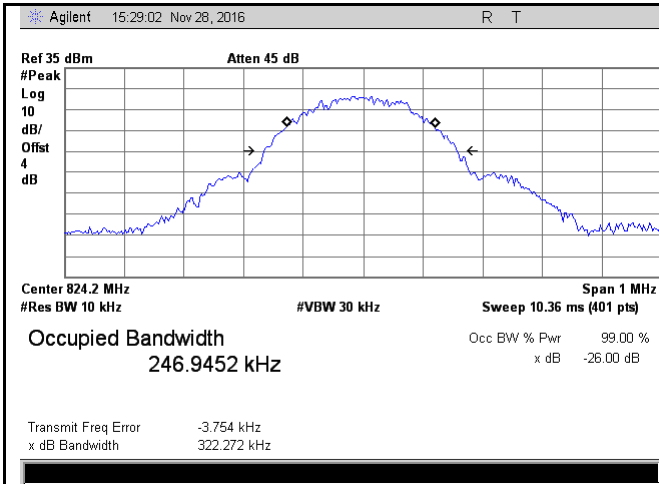

GSM 850 BW - Low CH 824.2MHz

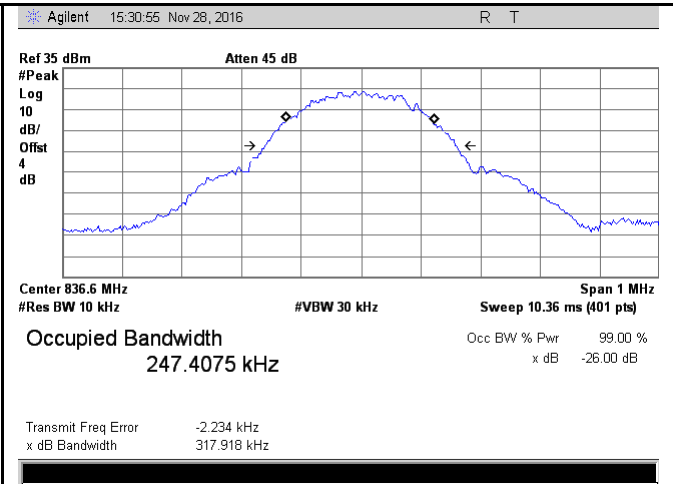

GSM 850 BW - Mid CH 836.6MHz

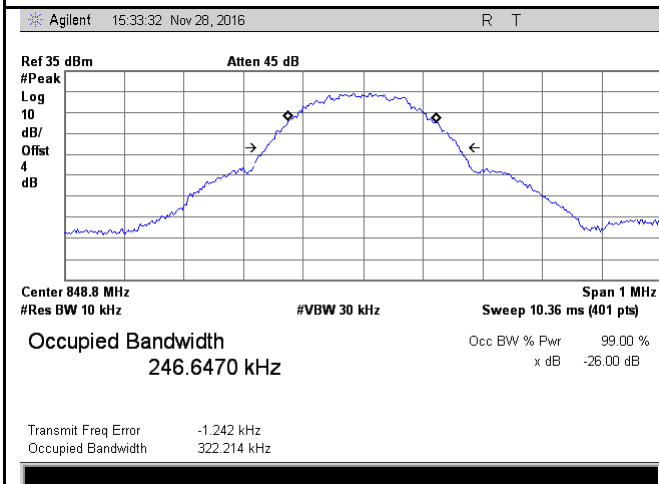

GSM 850 BW - High CH 848.8MHz

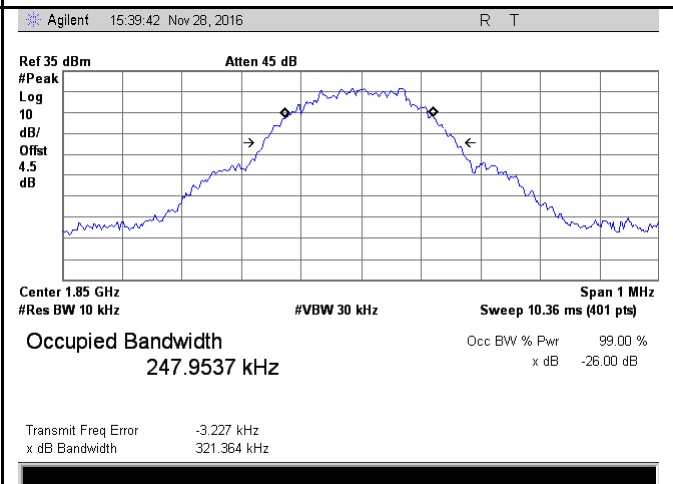

PCS 1900 BW - Low CH 1850.2MHz

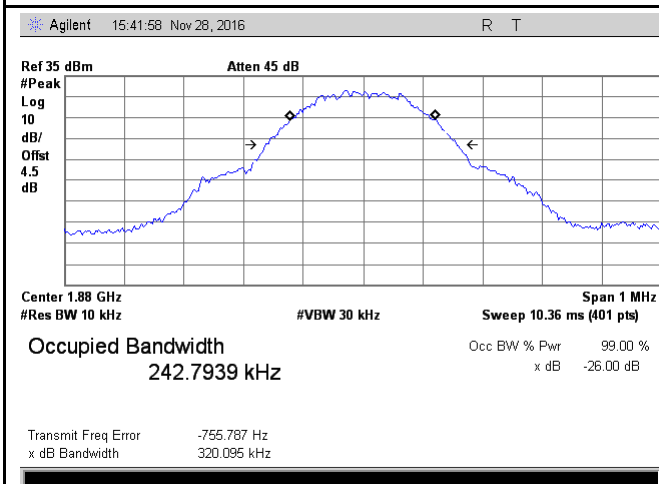

PCS 1900 BW - Mid CH 1880MHz

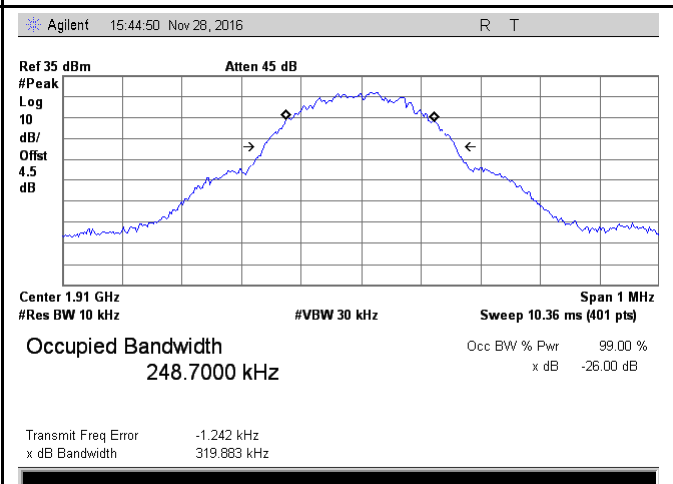

PCS 1900 BW - High CH 1909.8MHz

EGPRS (MCS5):

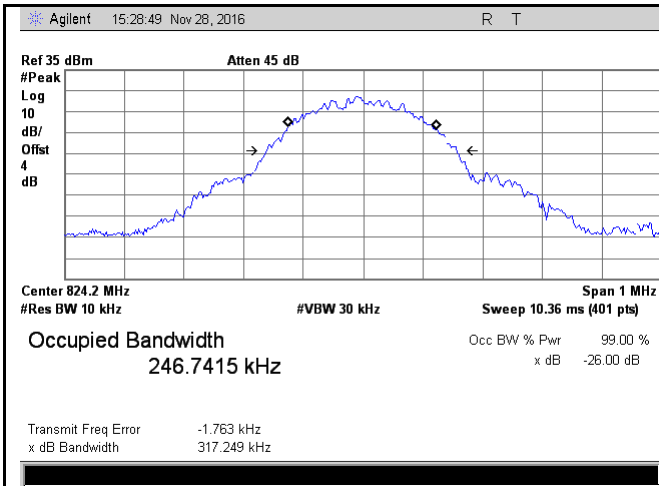

GSM 850 BW - Low CH 824.2MHz

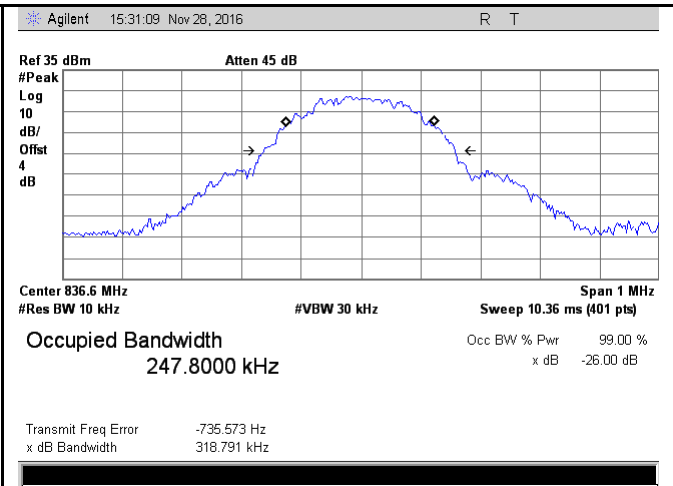

GSM 850 BW - Mid CH 836.6MHz

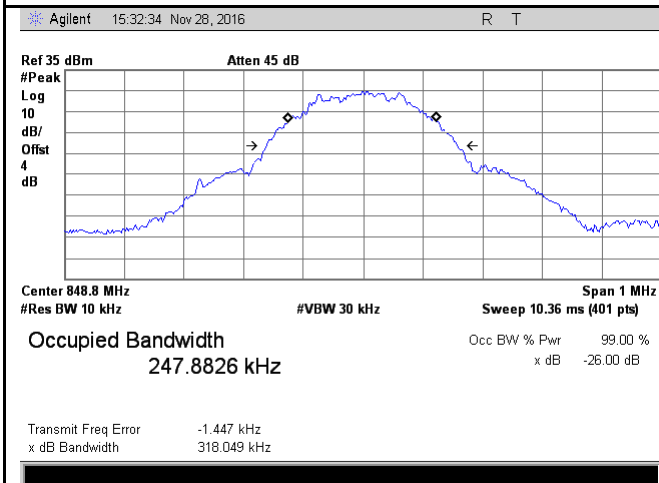

GSM 850 BW - High CH 848.8MHz

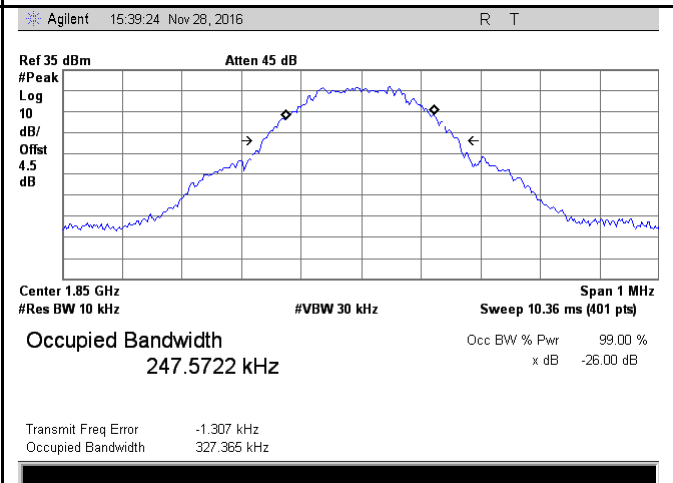

PCS 1900 BW - Low CH 1850.2MHz

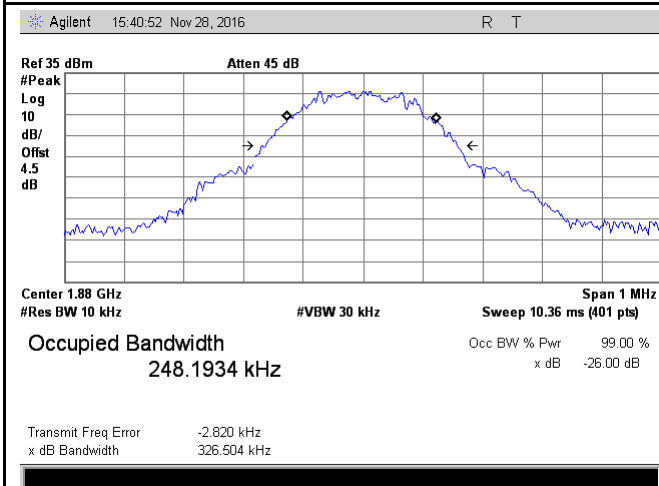

PCS 1900 BW - Mid CH 1880MHz

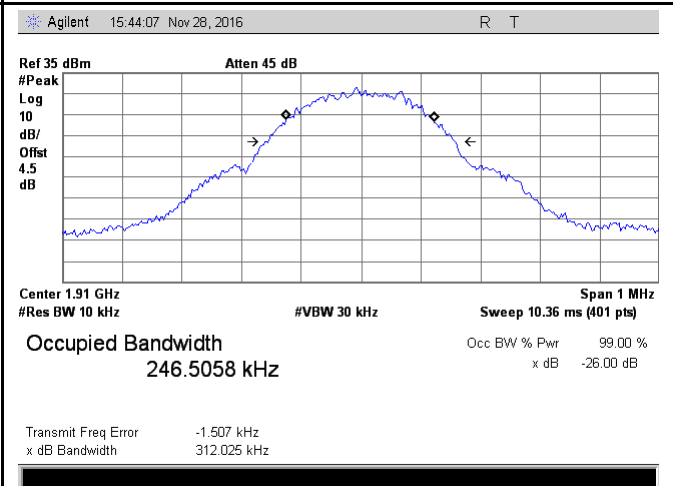

PCS 1900 BW - High CH 1909.8MHz

RMC:

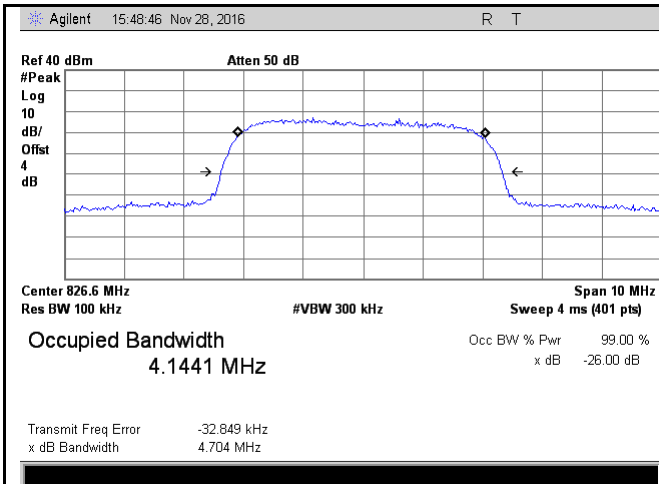

Band V BW - Low CH 826.6 MHz

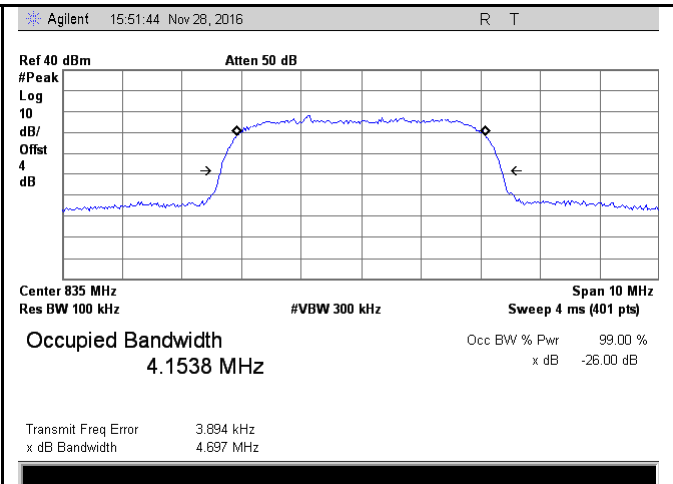

Band V BW - Mid CH 835.0 MHz

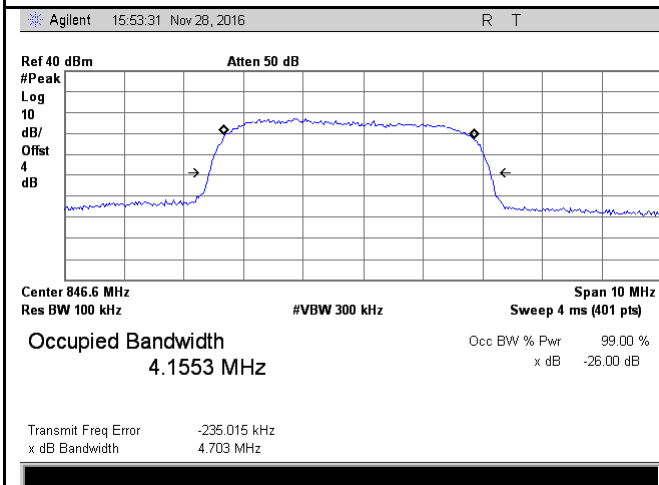

Band V BW - High CH 846.4 MHz

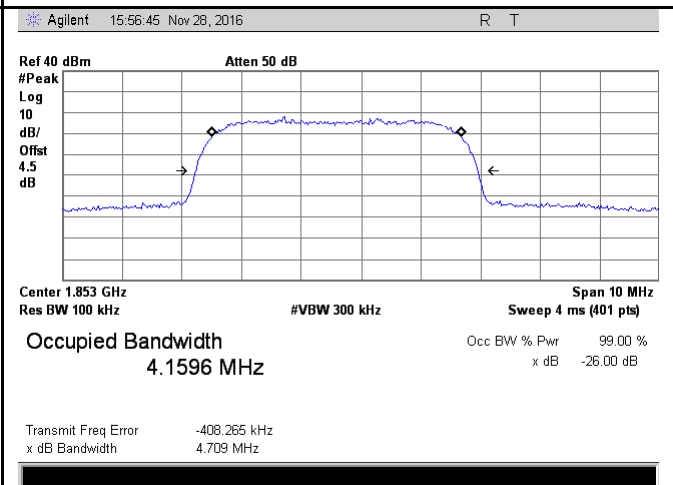

Band II BW - Low CH 1852.4MHz

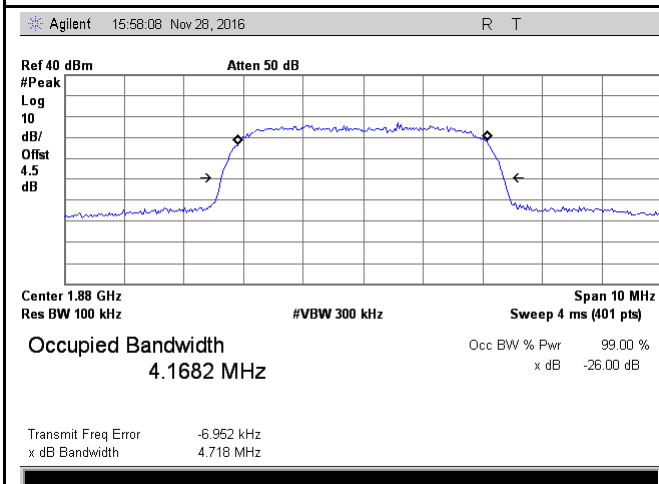

Band II BW - Mid CH 1880MHz

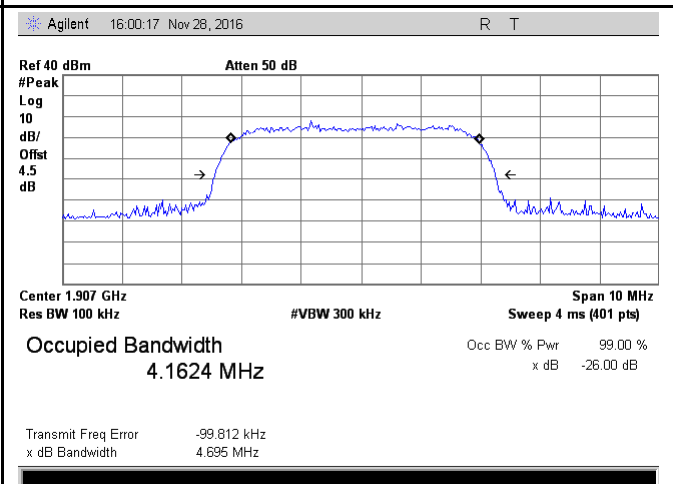

Band II BW - High CH 1907.6MHz

HSDPA:

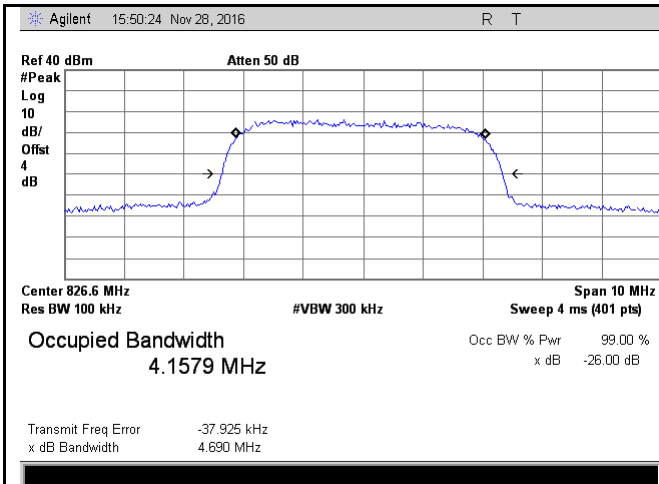

Band V BW - Low CH 826.6 MHz

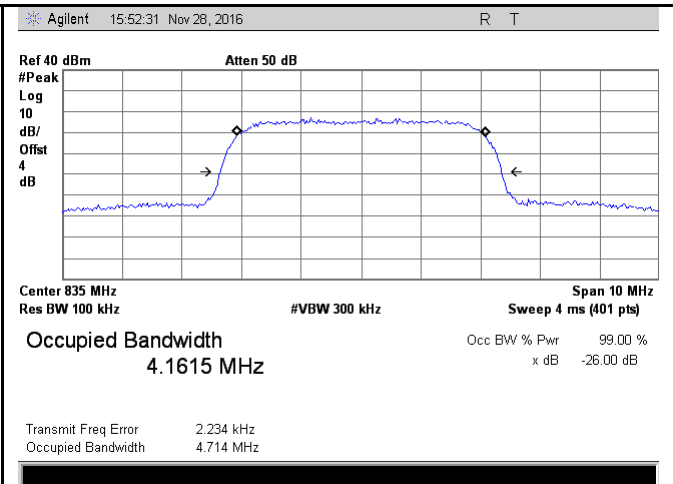

Band V BW - Mid CH 835.0 MHz

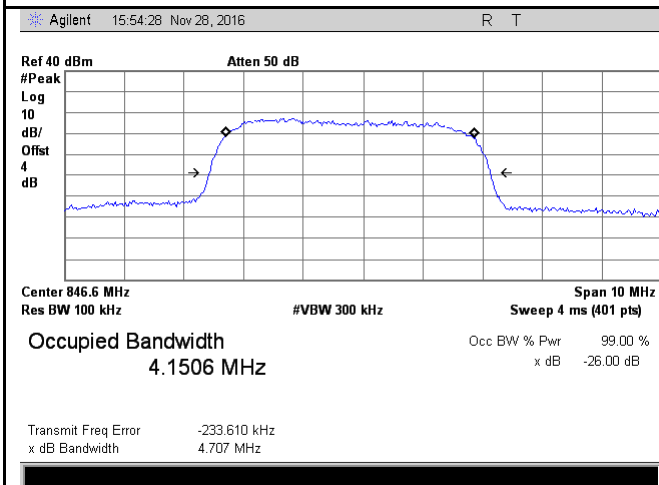

Band V BW - High CH 846.4 MHz

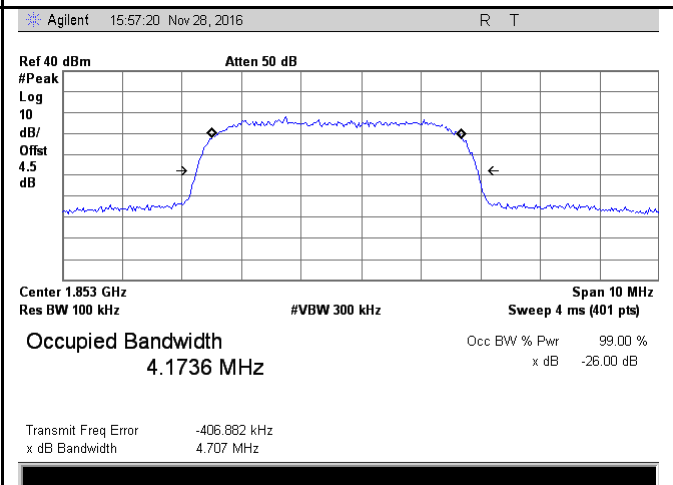

Band II BW - Low CH 1852.4MHz

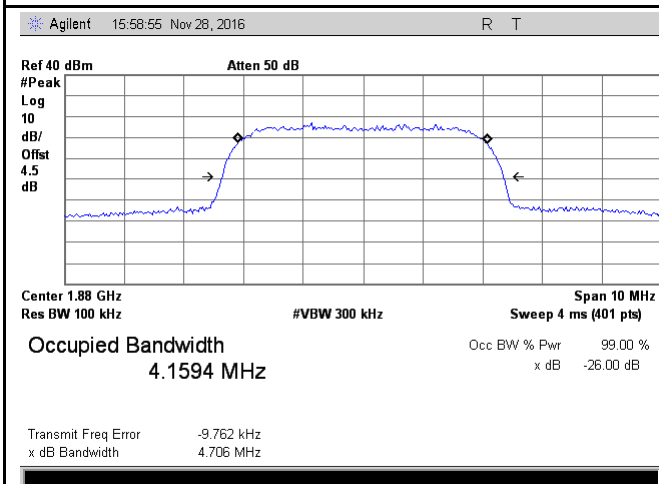

Band II BW - Mid CH 1880MHz

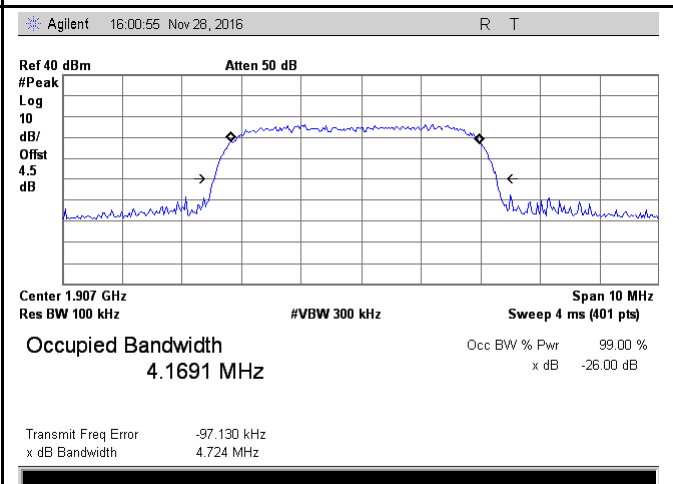

Band II BW - High CH 1907.6MHz

HSUPA:

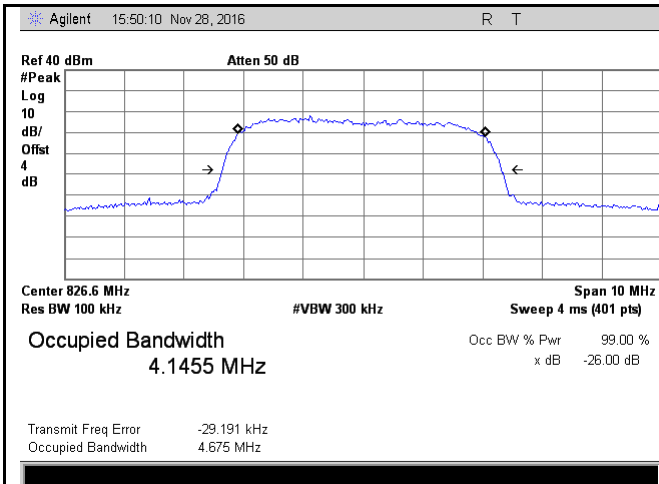

Band V BW - Low CH 826.6 MHz

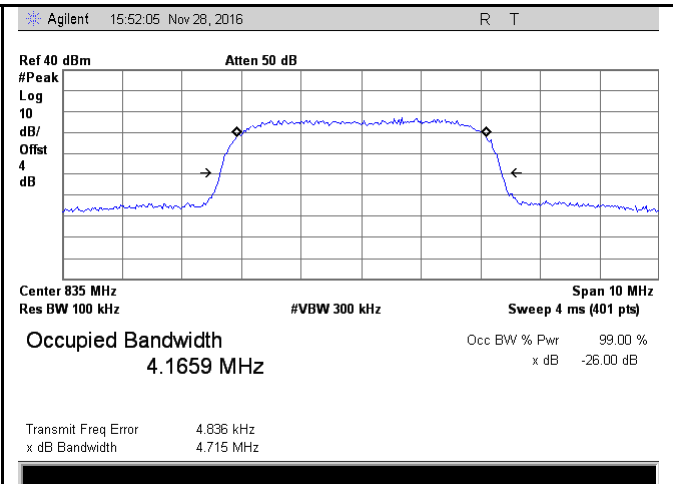

Band V BW - Mid CH 835.0 MHz

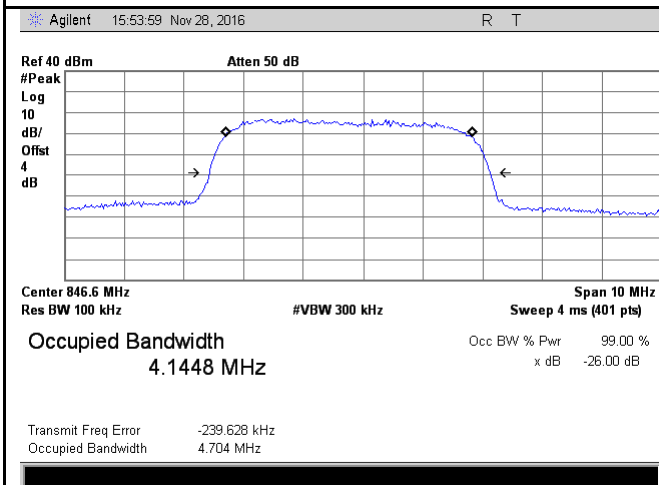

Band V BW - High CH 846.4 MHz

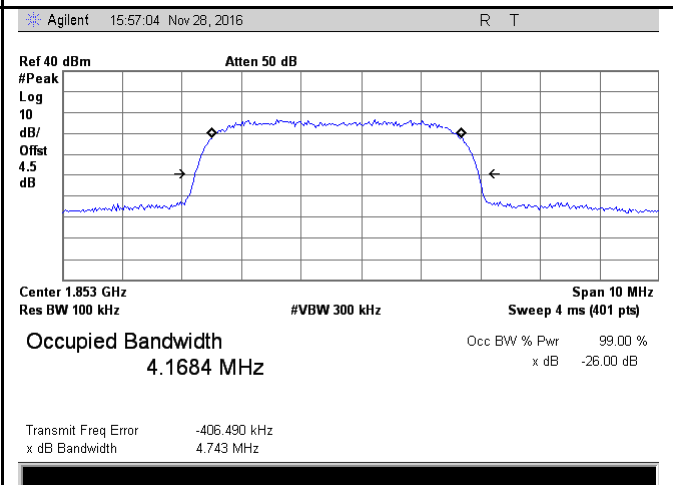

Band II BW - Low CH 1852.4MHz

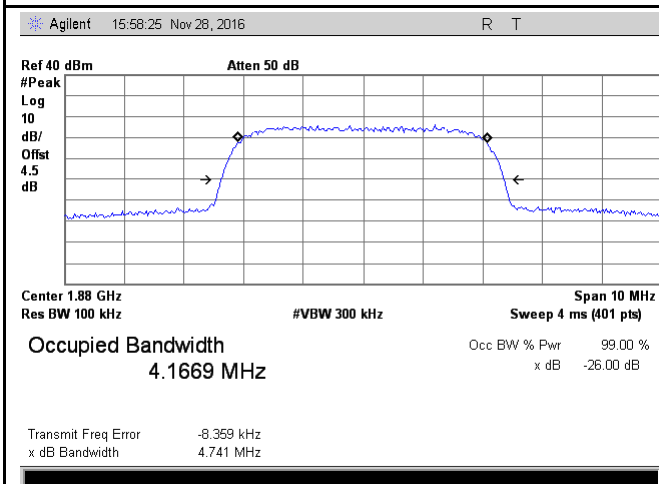

Band II BW - Mid CH 1880MHz

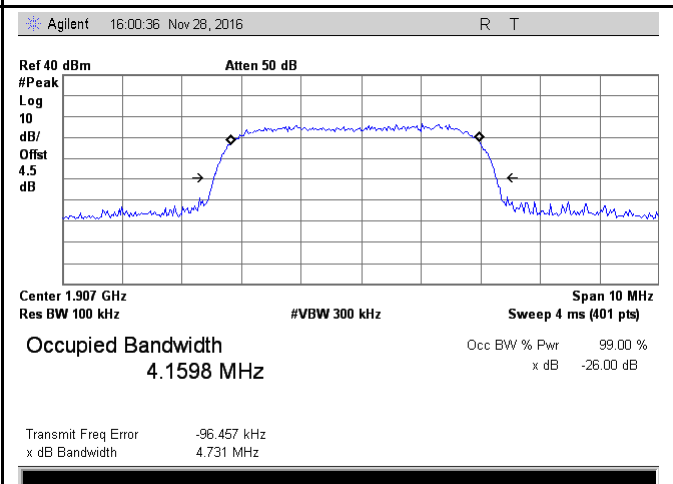

Band II BW - High CH 1907.6MHz

6.5 Spurious Emissions at Antenna Terminals

| | |
|----------------------|-------------------|
| Temperature | 25°C |
| Relative Humidity | 52% |
| Atmospheric Pressure | 1028mbar |
| Test date : | November 28, 2016 |
| Tested By : | Loren Luo |

Requirement(s):

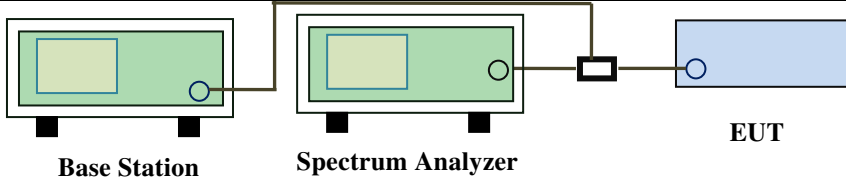
| Spec | Item | Requirement | Applicable |
|---------------------------------------|--|---|-------------------------------------|
| §2.1051, §22.917(a)& §24.238(a) | a) | The power of any emission outside of the authorized operating frequency ranges must be lower than the transmitter power (P) by a factor of at least $43 + 10 \log (P)$ dB | <input checked="" type="checkbox"/> |
| Test Setup |  <p>The diagram illustrates the test setup. On the left is a green box labeled 'Base Station'. In the middle is a green box labeled 'Spectrum Analyzer'. On the right is a blue box labeled 'EUT'. A power divider is connected between the Spectrum Analyzer and the EUT. The Base Station is connected to the Spectrum Analyzer.</p> | | |
| Test Procedure | <ul style="list-style-type: none"> - The EUT was connected to Spectrum Analyzer and Base Station via power divider. - The Band Edges of low and high channels for the highest RF powers were measured. - Setting RBW as roughly BW/100. | | |
| Remark | | | |
| Result | <input checked="" type="checkbox"/> Pass <input type="checkbox"/> Fail | | |

Test Data Yes N/A
 Test Plot Yes (See below) N/A

Test Plots

GSM Voice:

Cellular Band (Part 22H) result

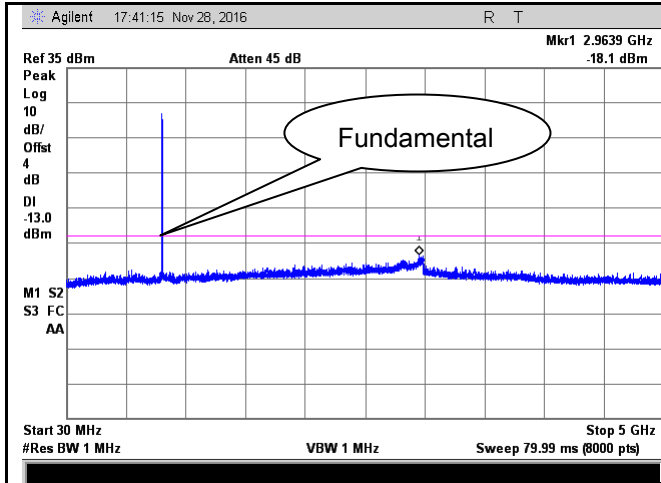

GSM 850 - Low Channel-1

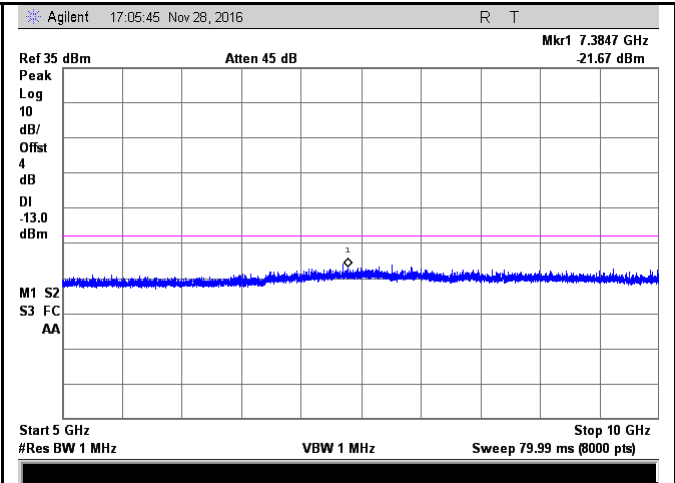

GSM 850 - Low Channel-2

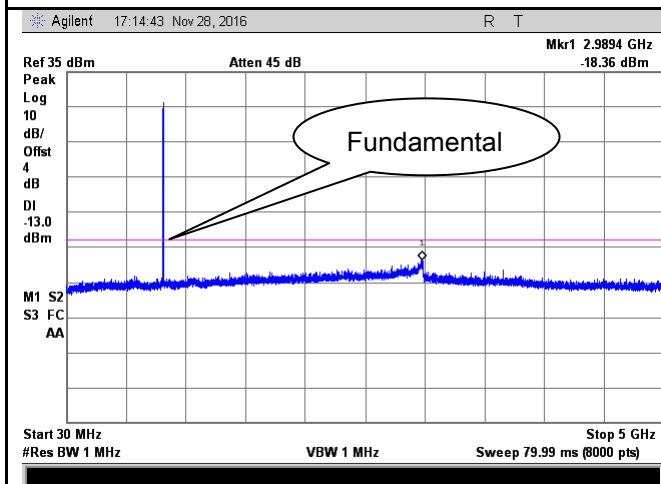

GSM 850 Middle Channel-1

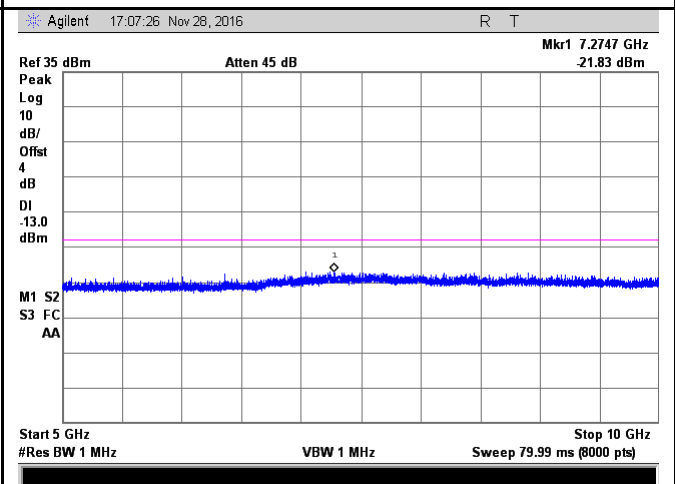

GSM 850 Middle Channel-2

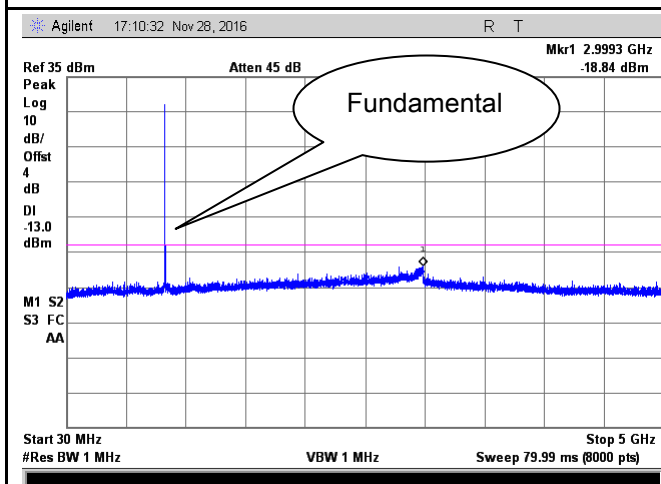

GSM 850 - High Channel-1

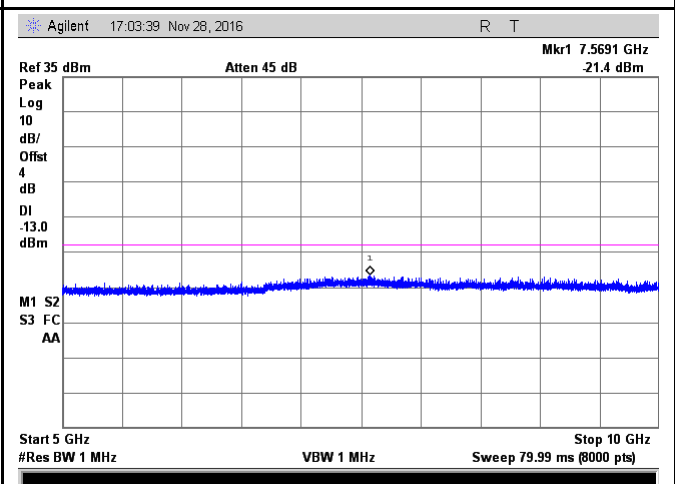

GSM 850 - High Channel-2

PCS Band (Part24E) result

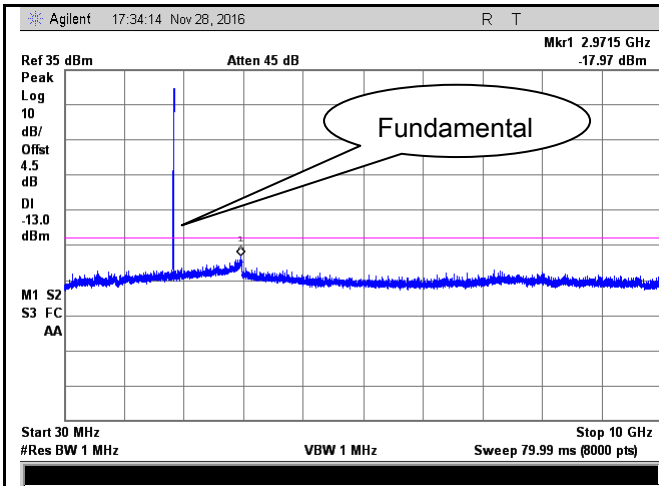

PCS1900 - Low Channel-1

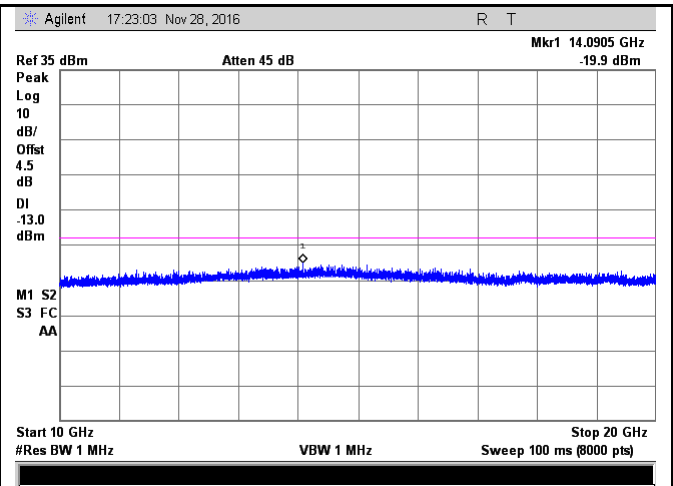

PCS 1900 - Low Channel-2

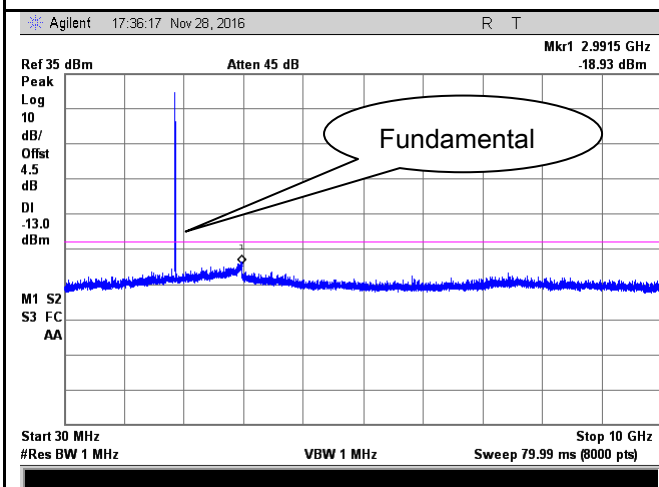

PCS1900 - Middle Channel-1

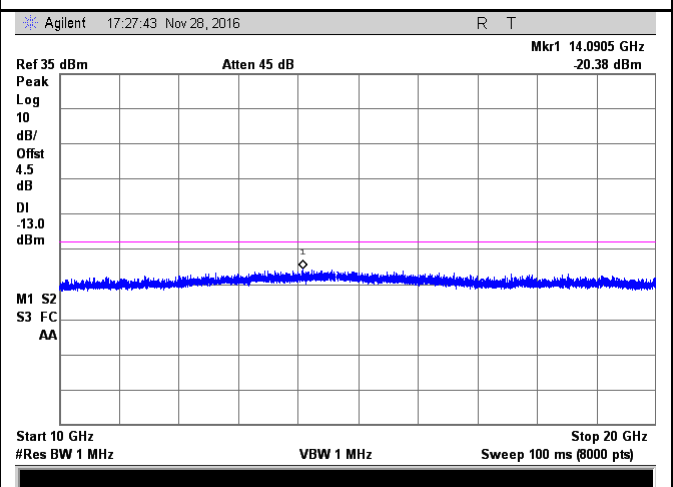

PCS 1900 - Middle Channel-2

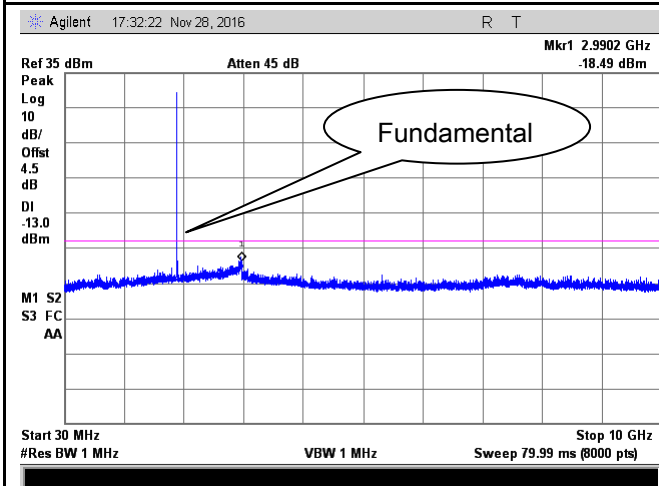

PCS1900 - High Channel-1

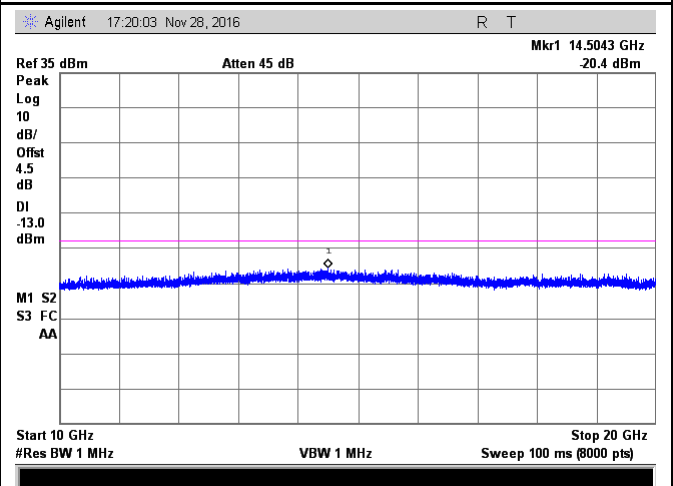

PCS 1900 - High Channel-2

GPRS:

Cellular Band (Part 22H) result

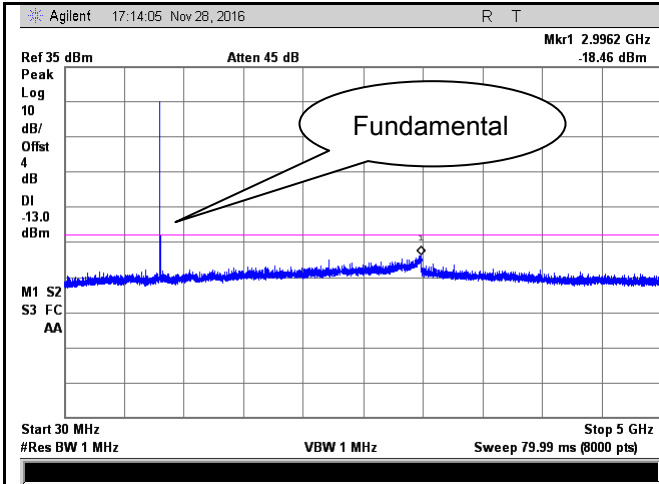

GSM 850 - Low Channel-1

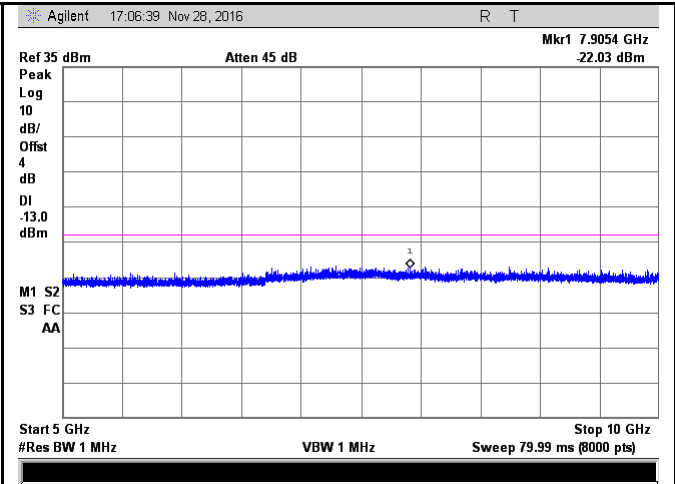

GSM 850 - Low Channel-2

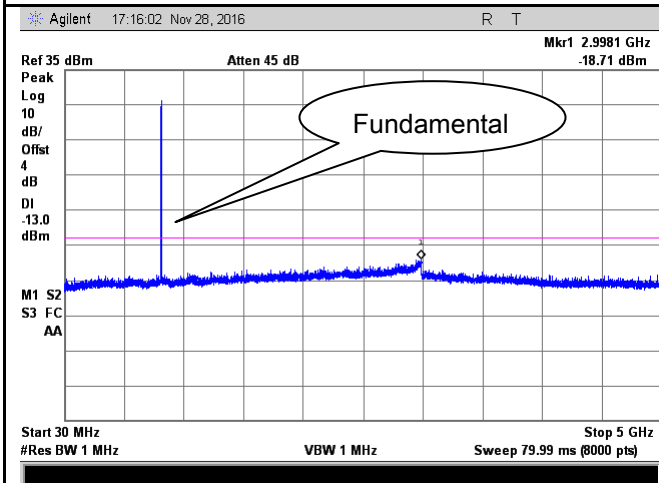

GSM 850 Middle Channel-1

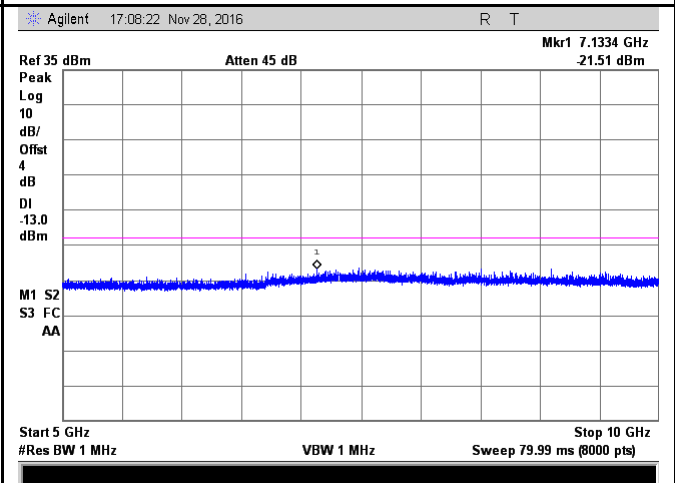

GSM 850 Middle Channel-2

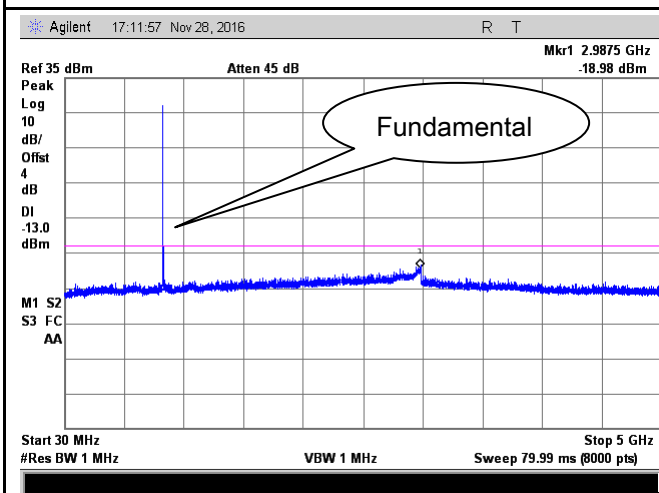

GSM 850 - High Channel-1

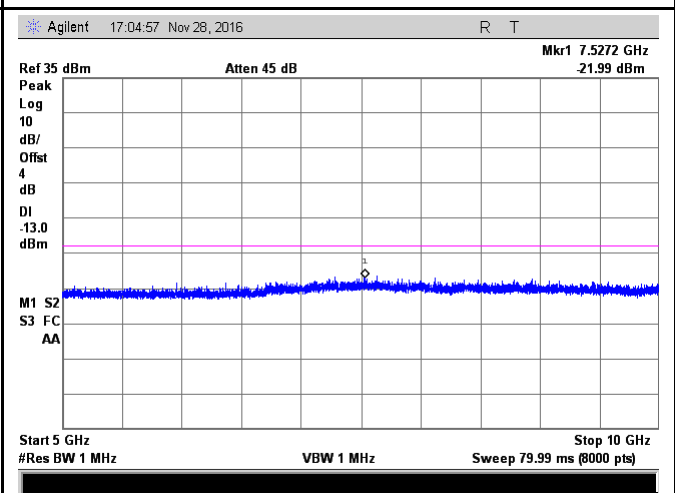

GSM 850 - High Channel-2

PCS Band (Part24E) result

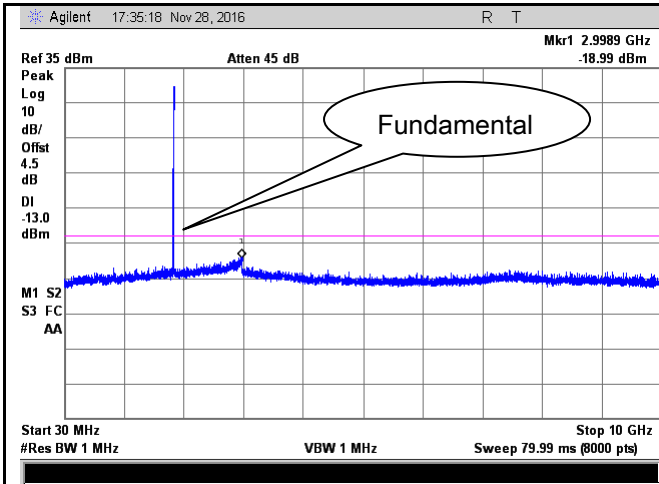

PCS1900 - Low Channel-1

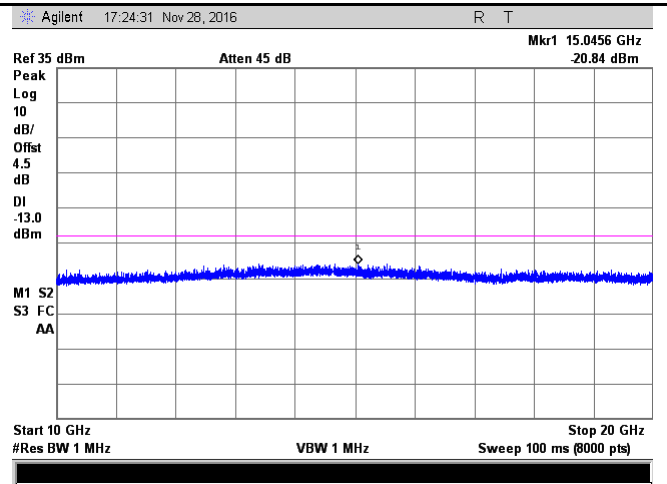

PCS 1900 - Low Channel-2

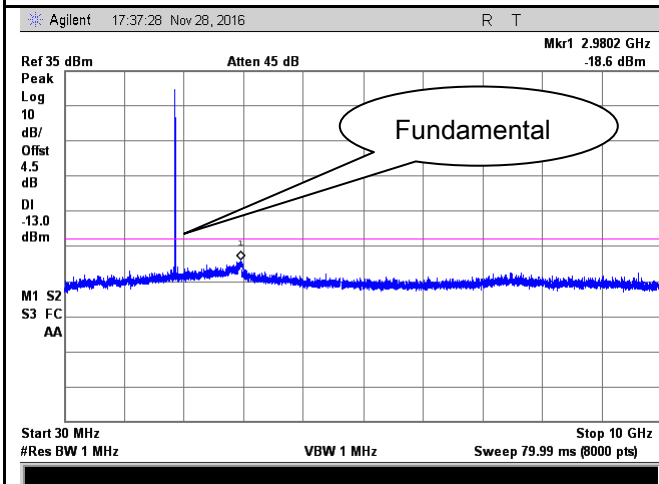

PCS1900 - Middle Channel-1

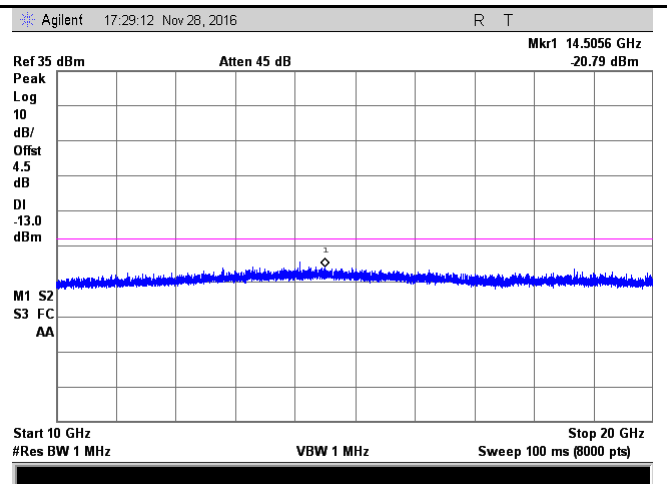

PCS 1900 - Middle Channel-2

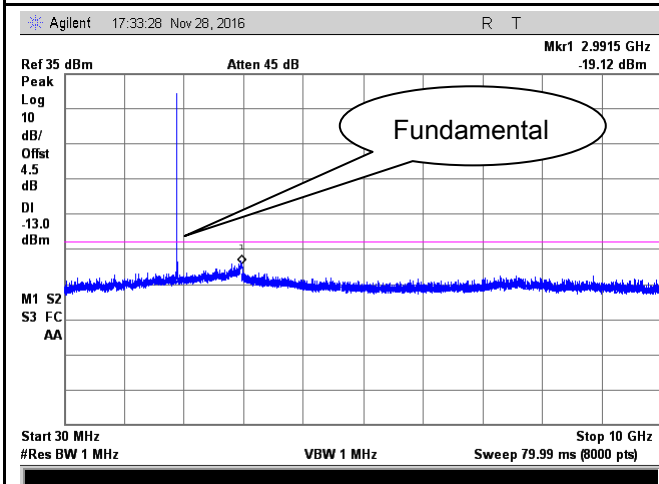

PCS1900 - High Channel-1

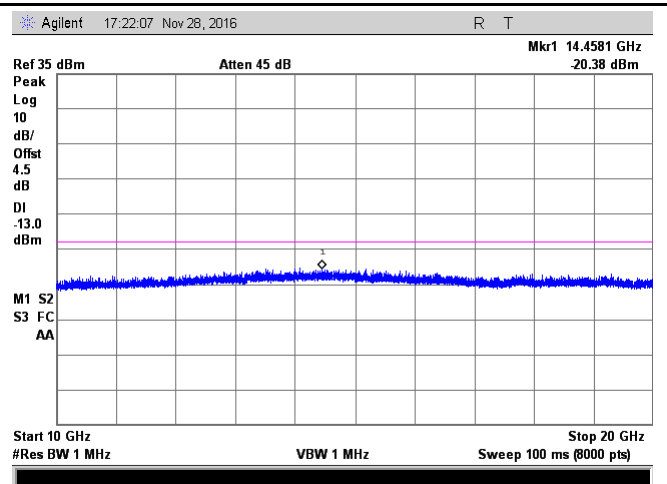

PCS 1900 - High Channel-2

EGPRS (MCS 5):
Cellular Band (Part 22H) result

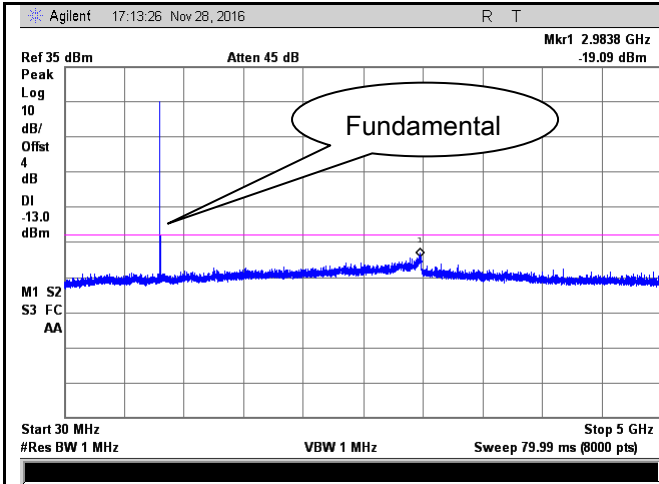

GSM 850 - Low Channel-1

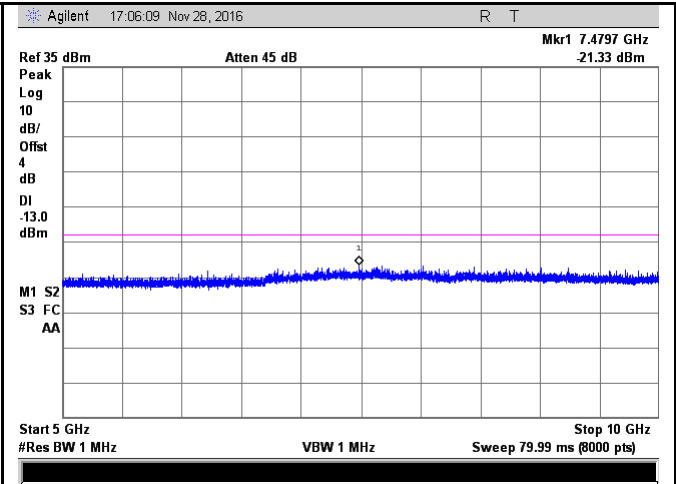

GSM 850 - Low Channel-2

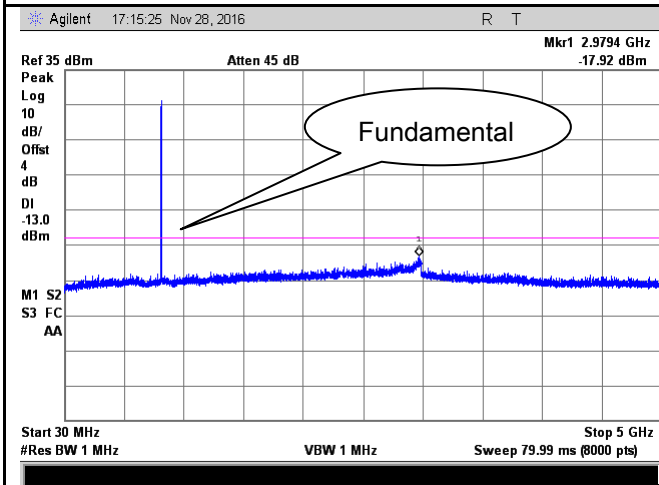

GSM 850 Middle Channel-1

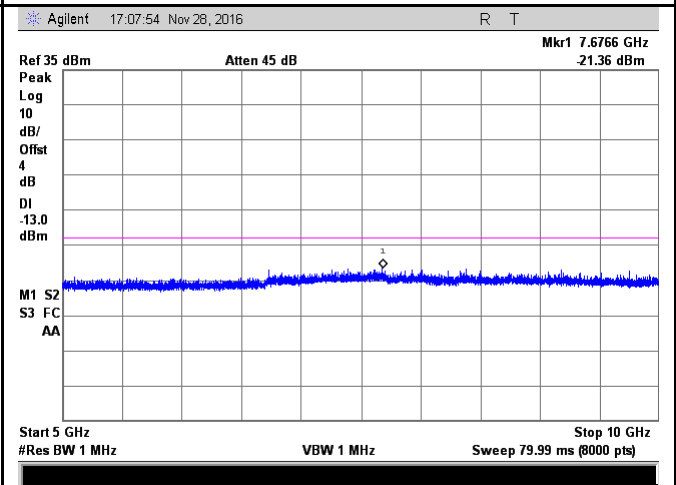

GSM 850 Middle Channel-2

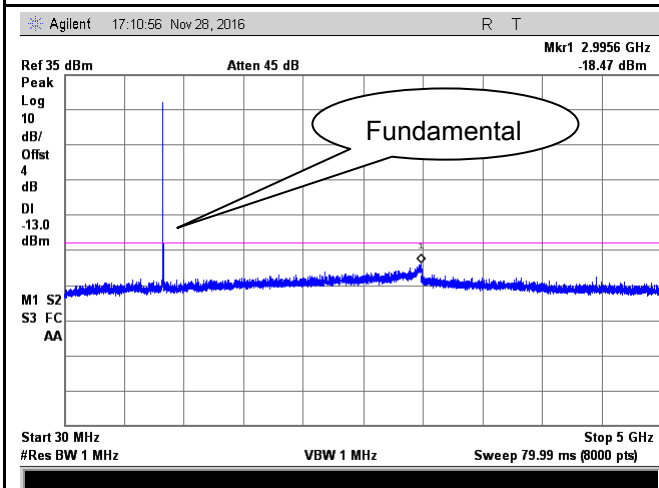

GSM 850 - High Channel-1

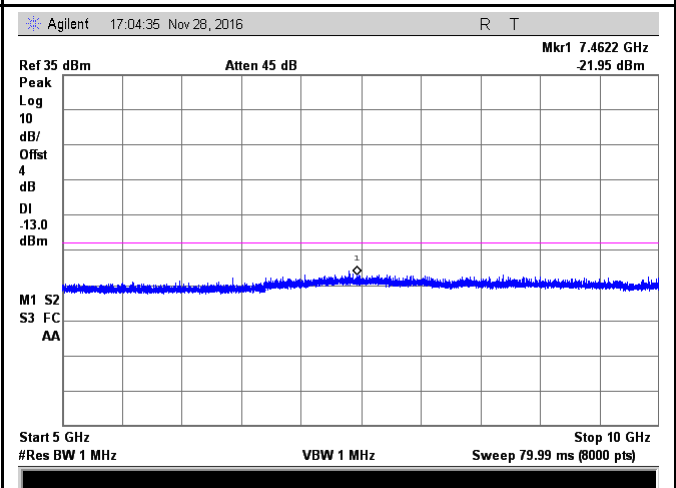

GSM 850 - High Channel-2

PCS Band (Part24E) result

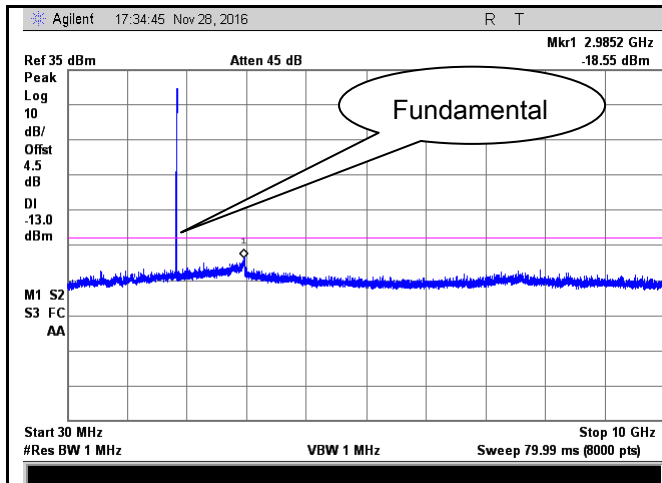

PCS1900 - Low Channel-1

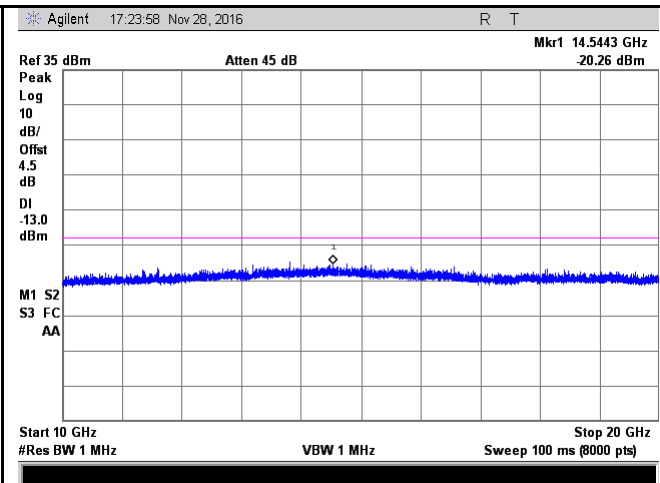

PCS 1900 - Low Channel-2

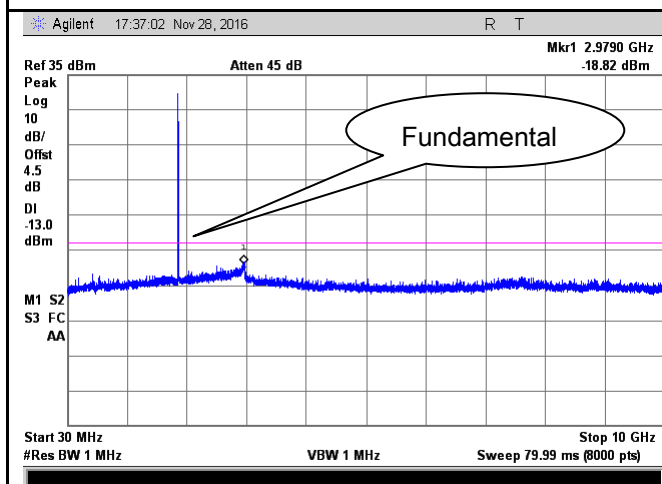

PCS1900 - Middle Channel-1

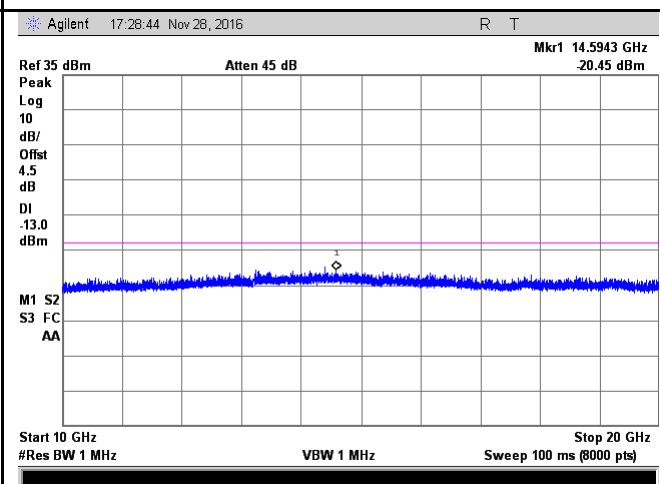

PCS 1900 - Middle Channel-2

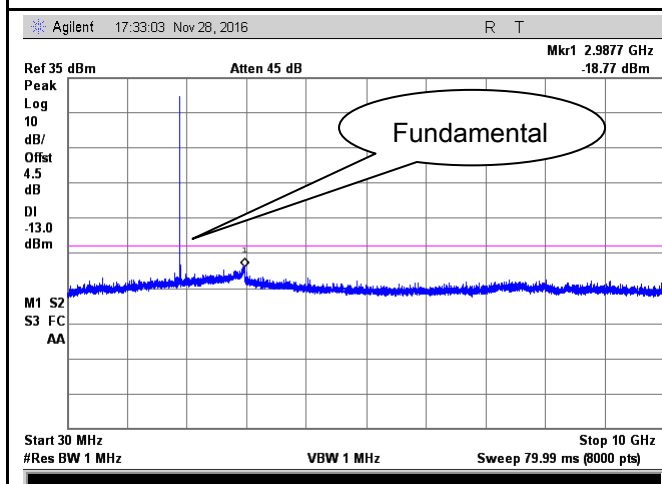

PCS1900 - High Channel-1

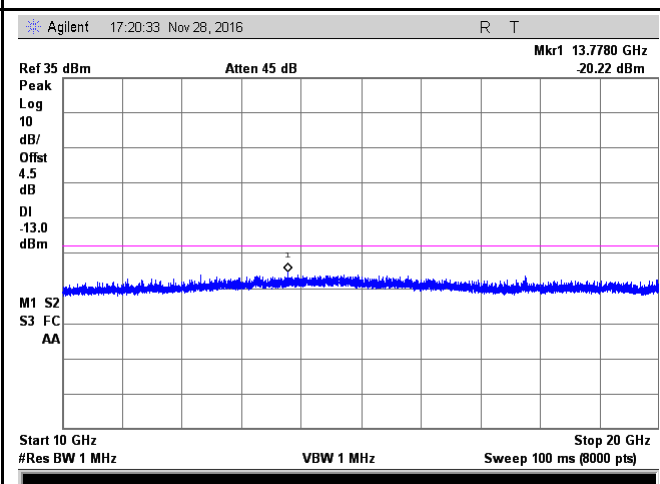

PCS 1900 - High Channel-2

RMC

UMTS-FDD Band V (Part 22H)

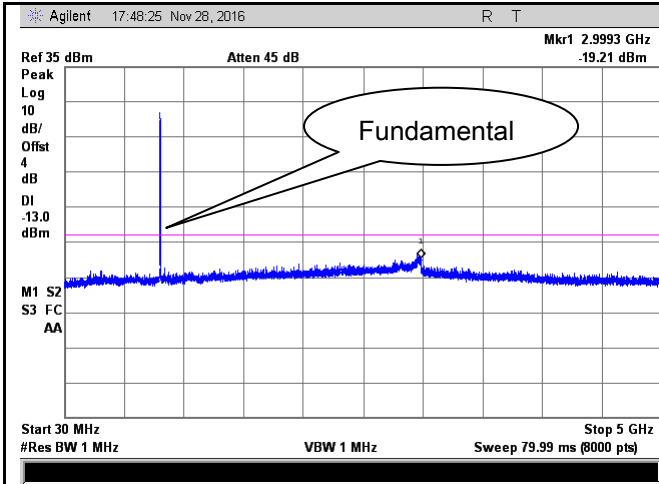

Band V - Low Channel-1

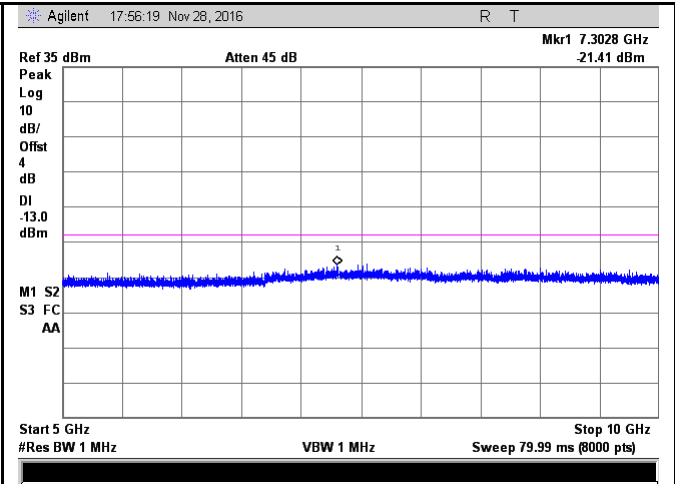

Band V - Low Channel-2

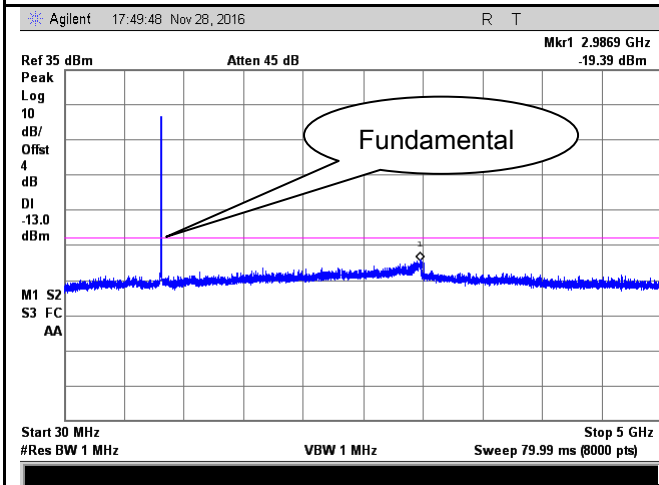

Band V - Middle Channel-1

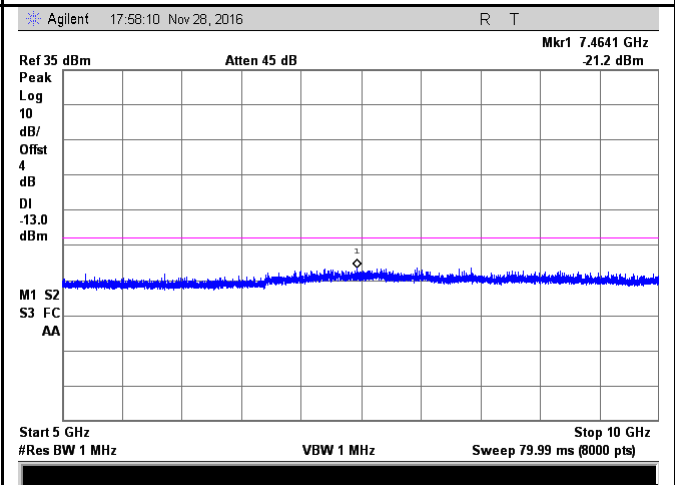

Band V - Middle Channel-2

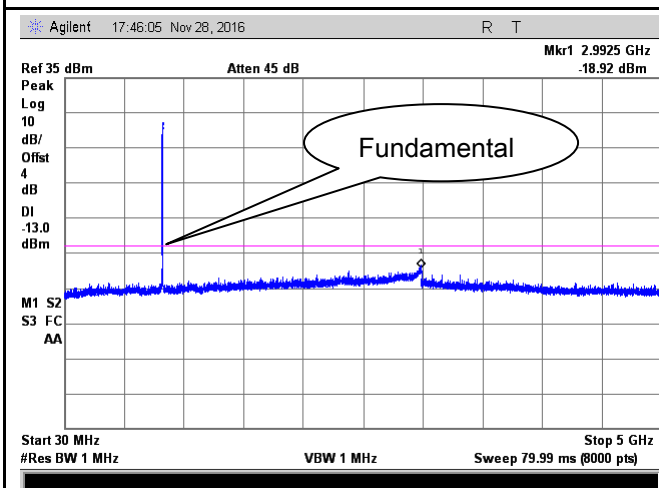

Band V - High Channel-1

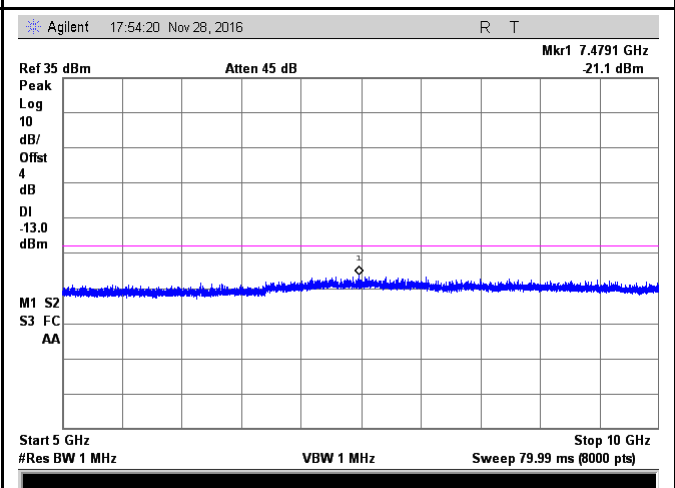

Band V - High Channel-2

UMTS-FDD Band II (Part 24E)

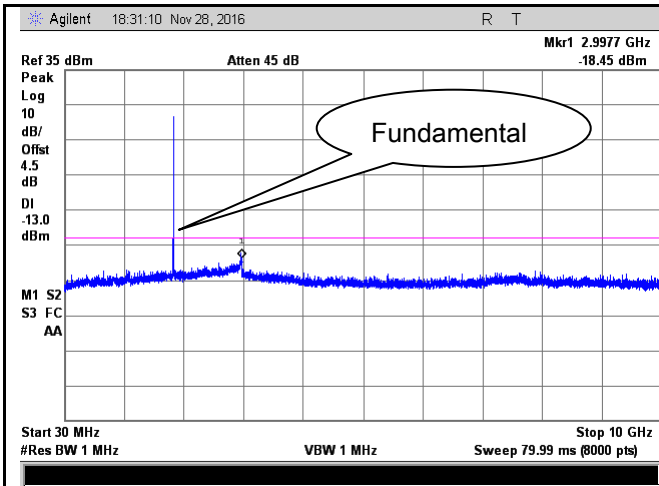

Band II - Low Channel-1

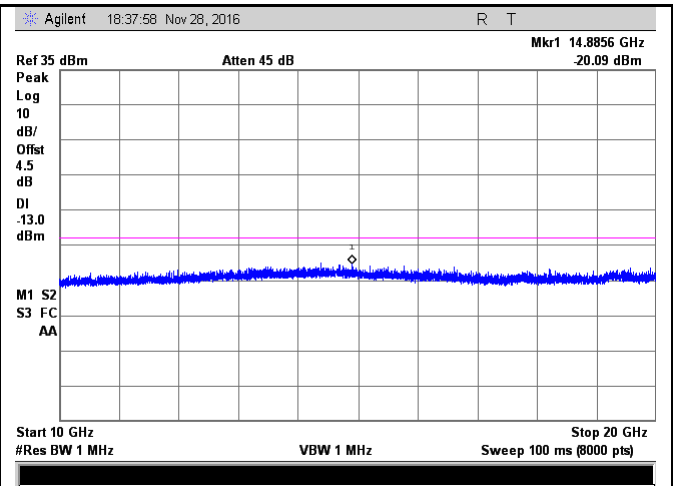

Band II - Low Channel-2

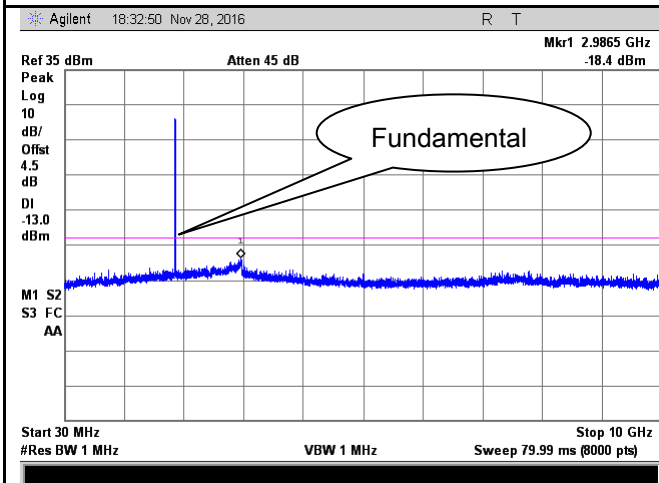

Band II - Middle Channel-1

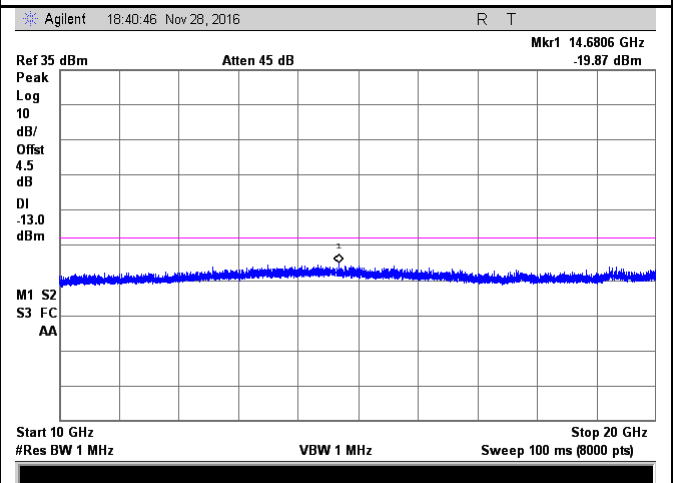

Band II - Middle Channel-2

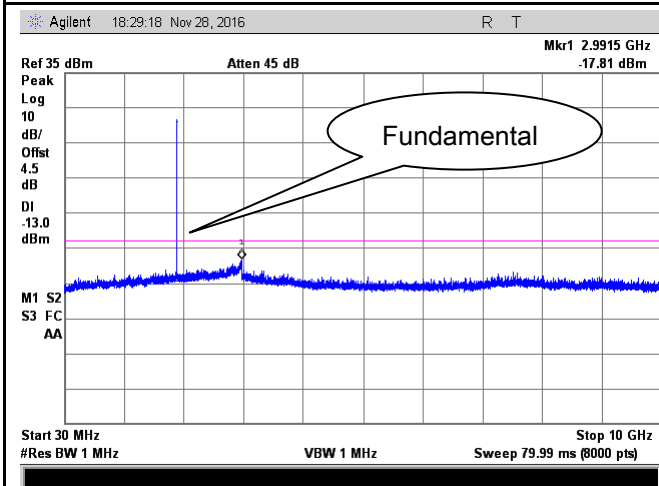

Band II - High Channel-1

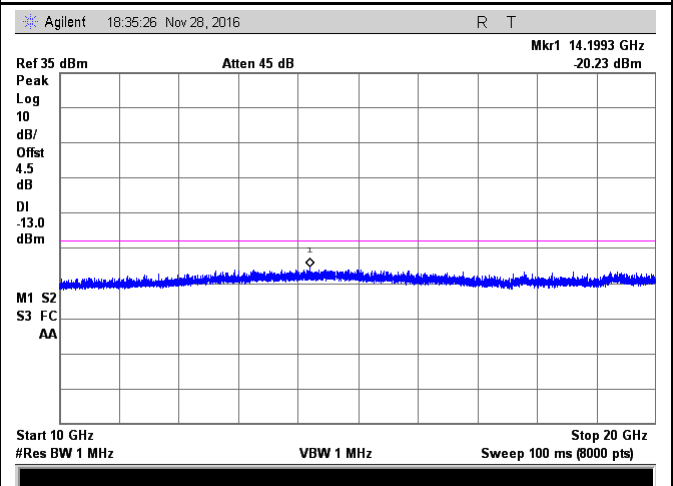

Band II - High Channel-2

HSDPA:

UMTS-FDD Band V (Part 22H)

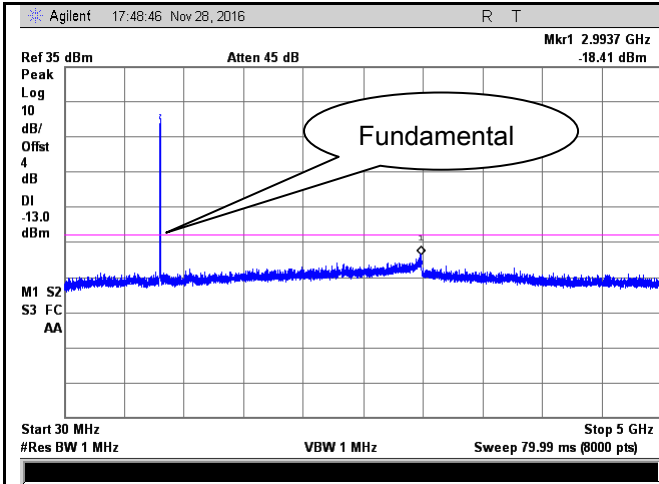

Band V - Low Channel-1

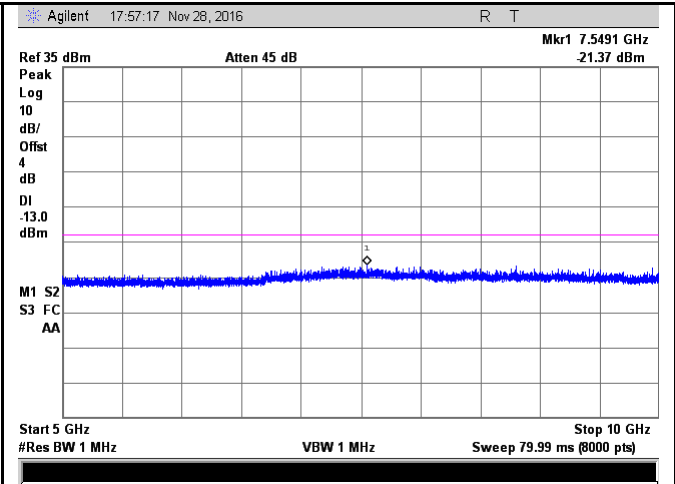

Band V - Low Channel-2

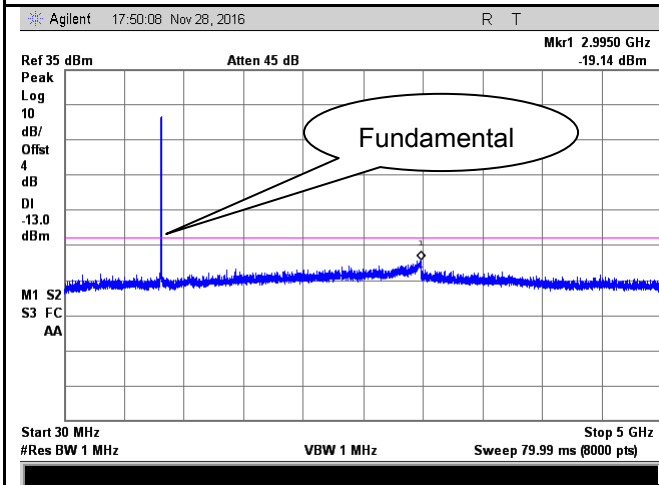

Band V - Middle Channel-1

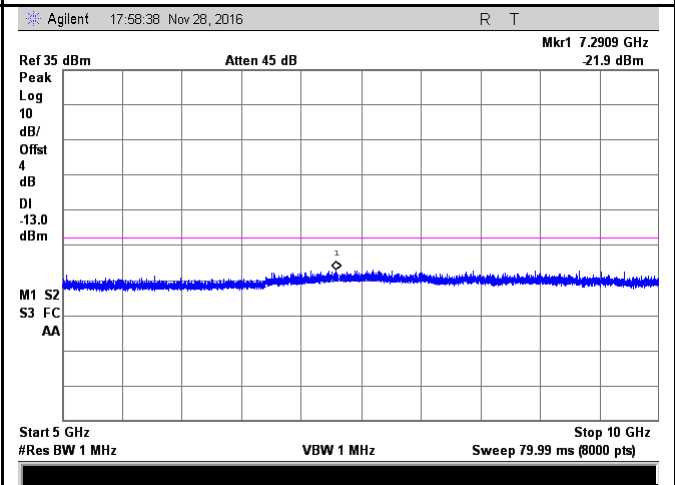

Band V - Middle Channel-2

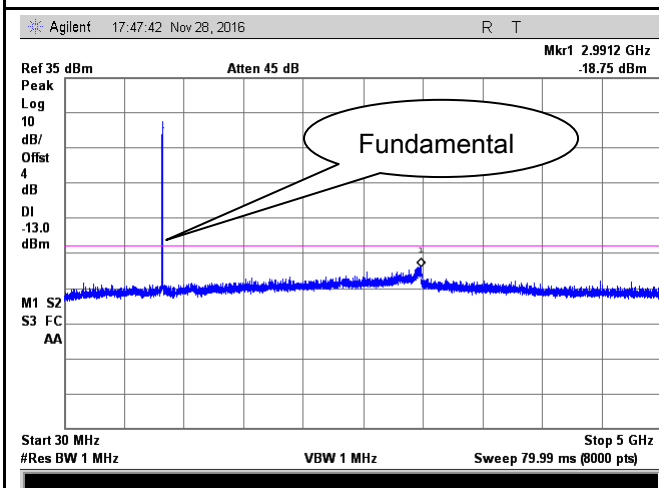

Band V - High Channel-1

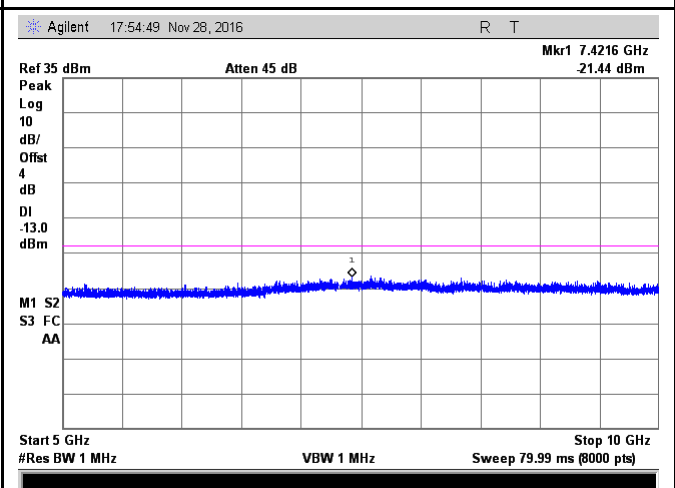

Band V - High Channel-2

UMTS-FDD Band II (Part 24E)

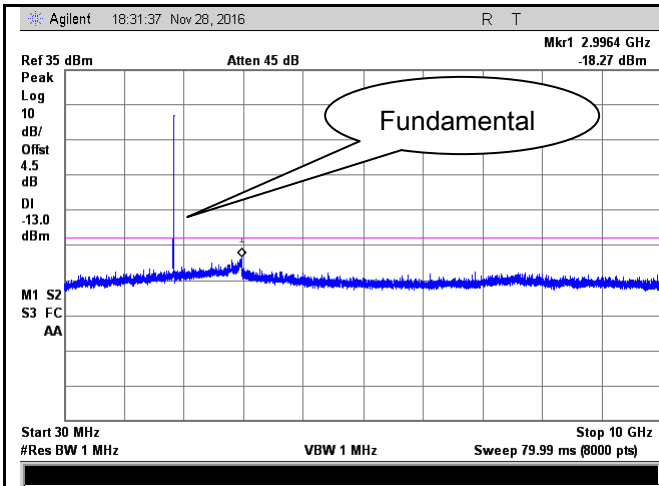

Band II - Low Channel-1

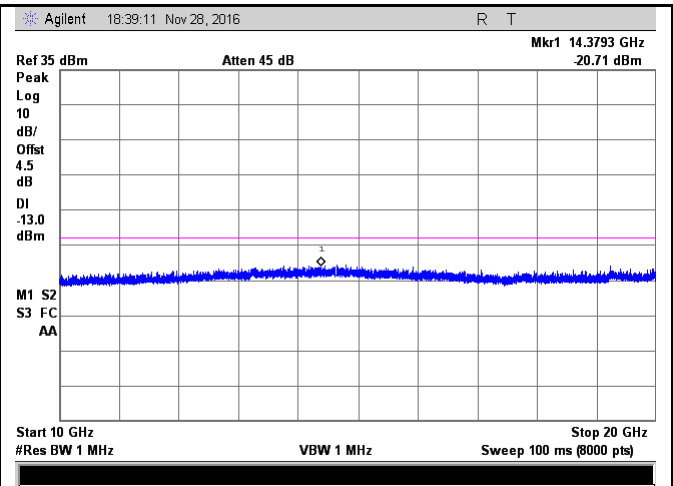

Band II - Low Channel-2

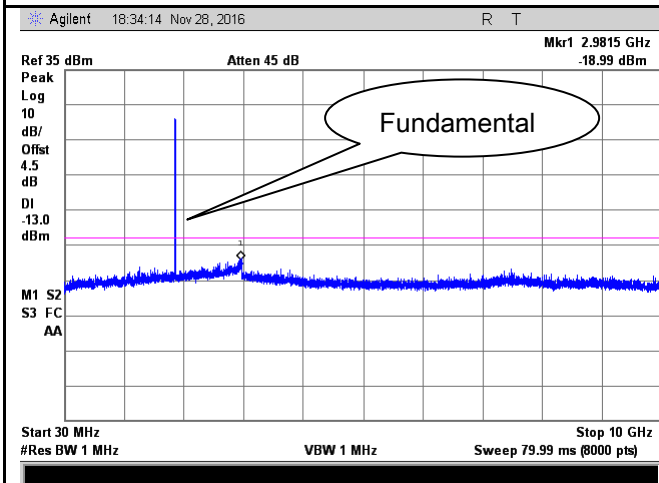

Band II - Middle Channel-1

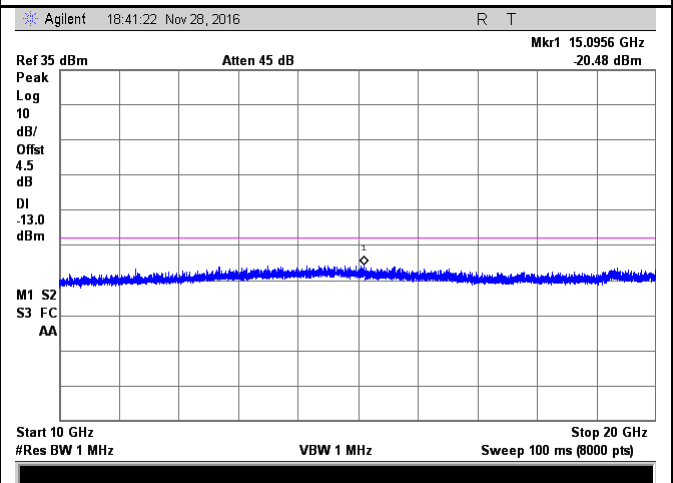

Band II - Middle Channel-2

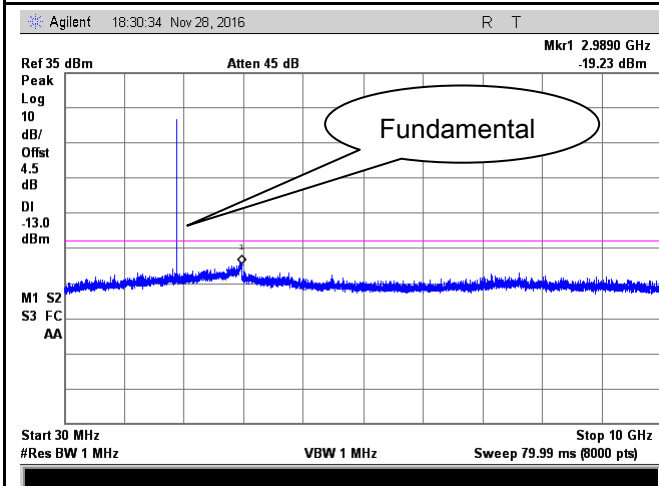

Band II - High Channel-1

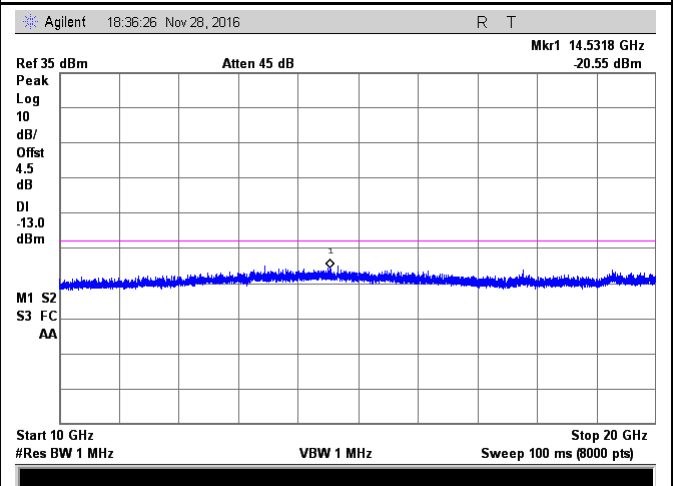

Band II - High Channel-2

HSUPA:

UMTS-FDD Band V (Part 22H)

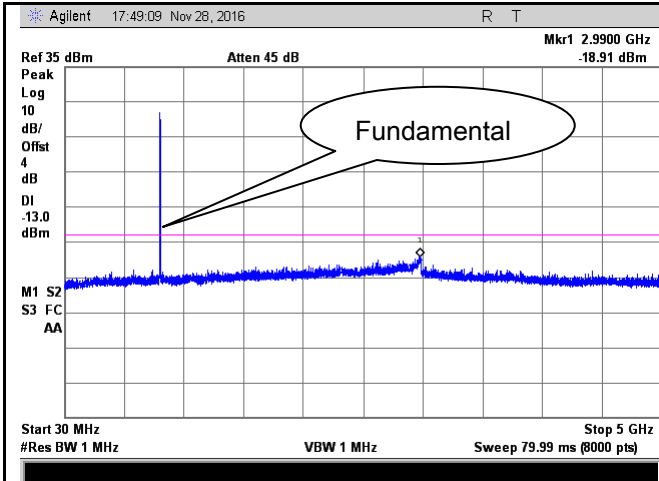

Band V - Low Channel-1

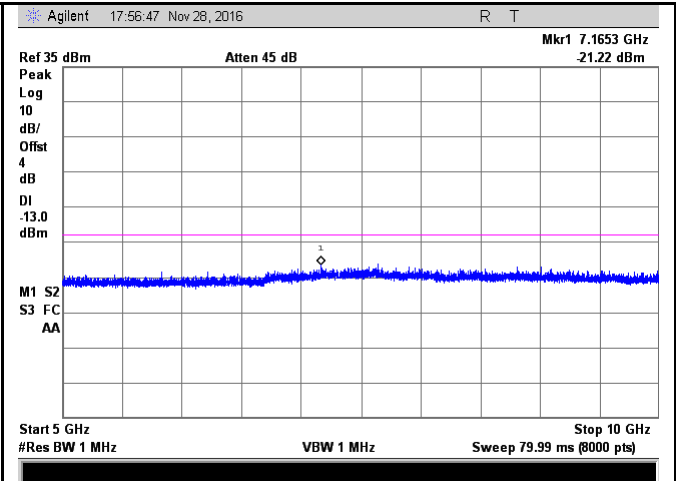

Band V - Low Channel-2

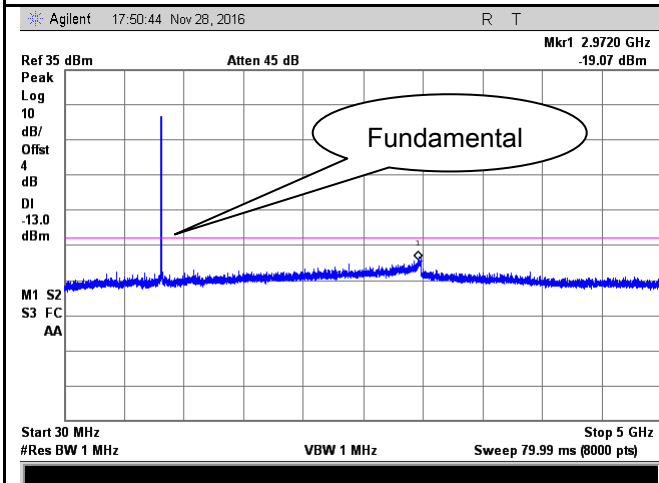

Band V - Middle Channel-1

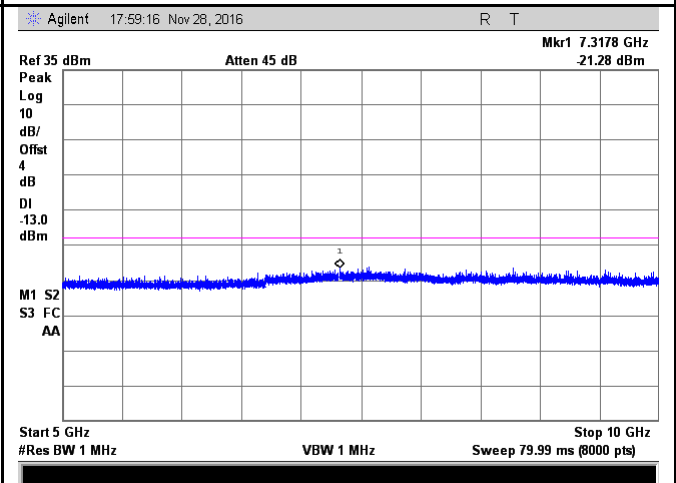

Band V - Middle Channel-2

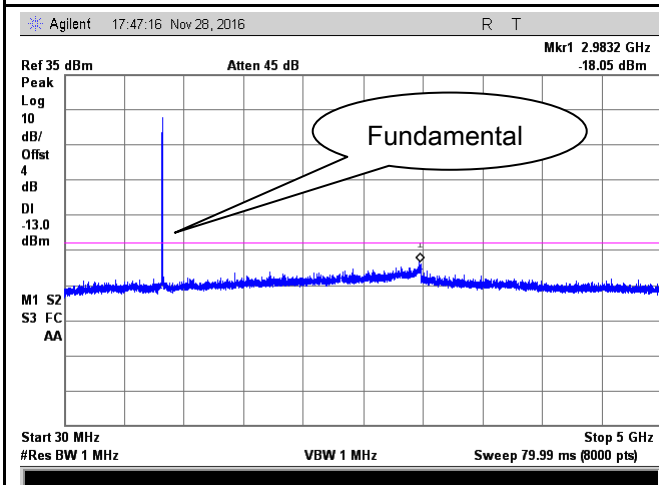

Band V - High Channel-1

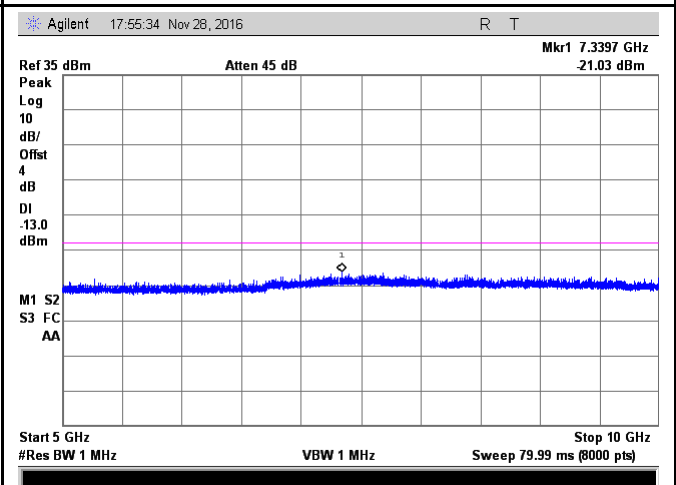

Band V - High Channel-2

UMTS-FDD Band II (Part 24E)

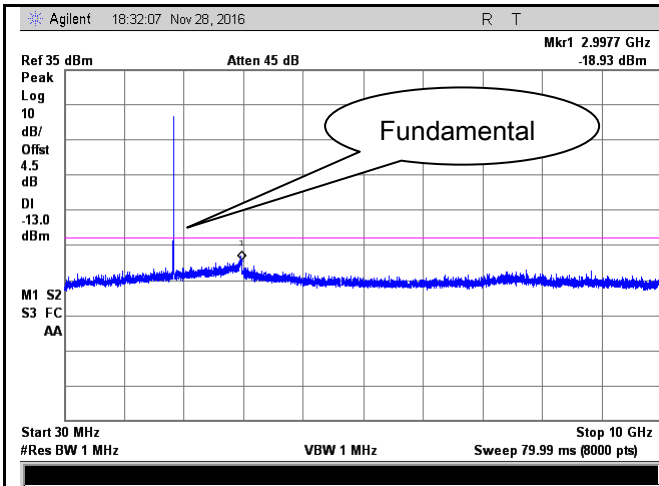

Band II - Low Channel-1

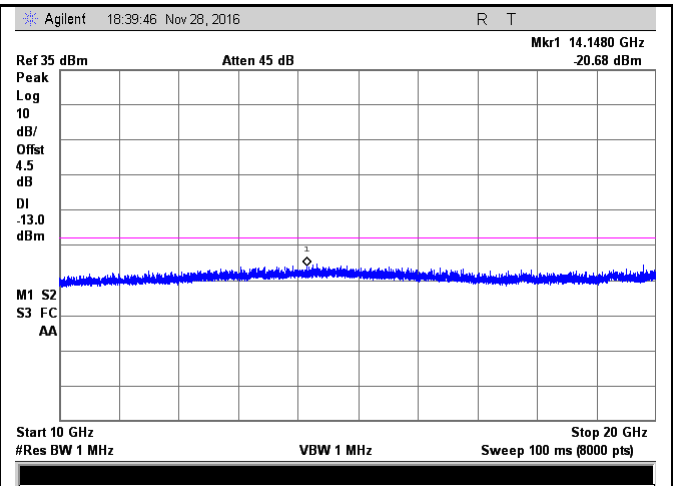

Band II - Low Channel-2

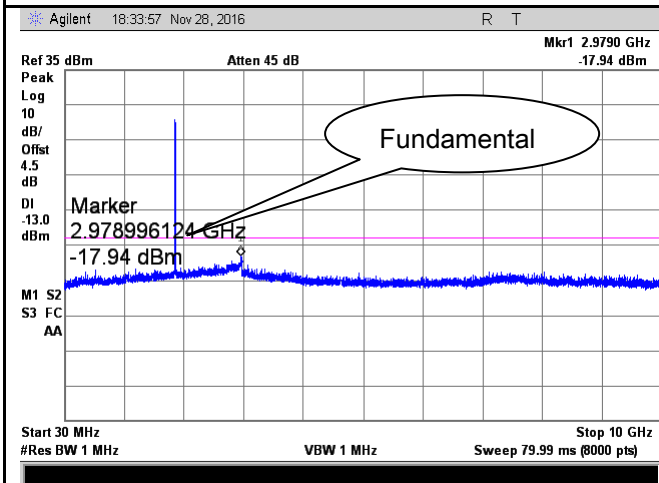

Band II - Middle Channel-1

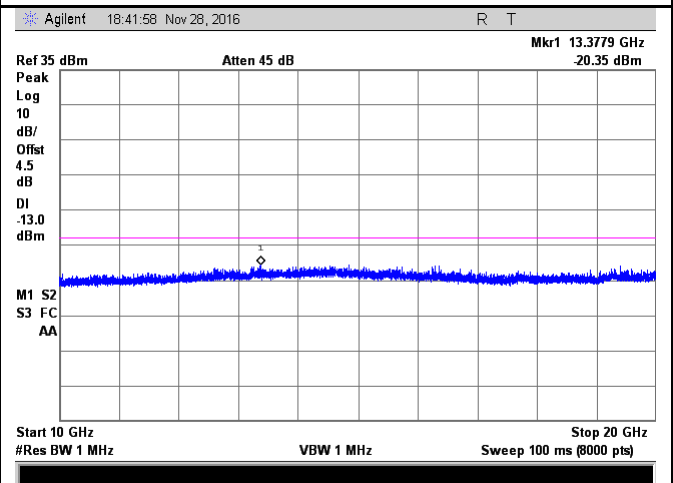

Band II - Middle Channel-2

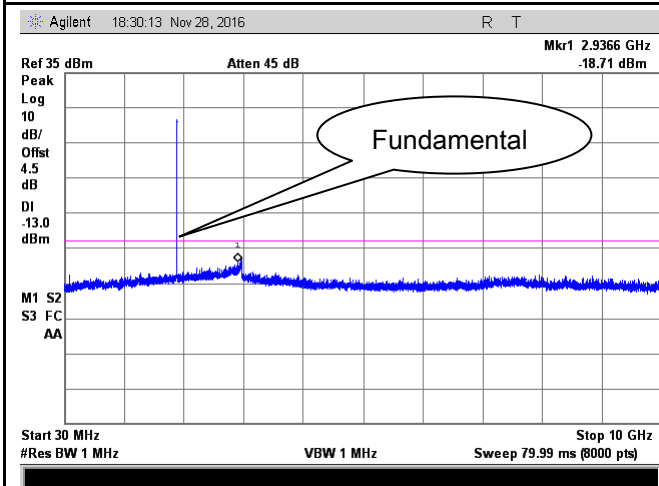

Band II - High Channel-1

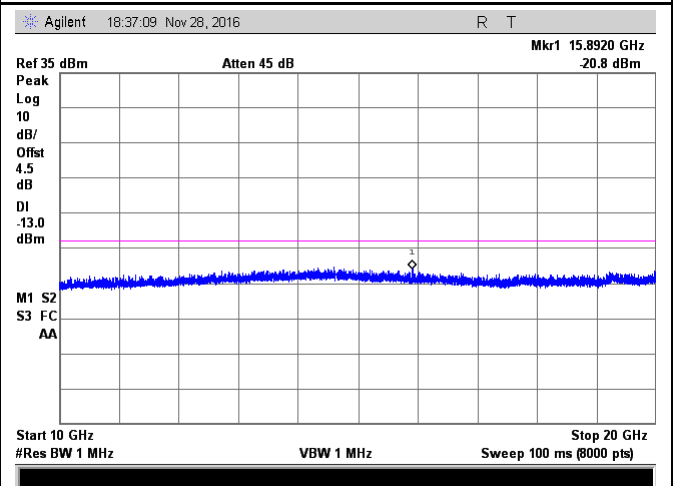

Band II - High Channel-2

6.6 Spurious Radiated Emissions

| | |
|----------------------|-------------------|
| Temperature | 25°C |
| Relative Humidity | 52% |
| Atmospheric Pressure | 1028mbar |
| Test date : | November 28, 2016 |
| Tested By : | Loren Luo |

Requirement(s):

| Spec | Item | Requirement | Applicable |
|----------------------------------|------|---|-------------------------------------|
| §2.1053, §22.917 & §24.238 | a) | The power of any emission outside of the authorized operating frequency ranges must be attenuated below the transmitter power (P) by a factor of at least $43 + 10 \log (P)$ dB. The spectrum is scanned from 30 MHz up to a frequency including its 10th harmonic. | <input checked="" type="checkbox"/> |

| | |
|------------|--|
| Test setup | |
|------------|--|

| | |
|----------------|---|
| Test Procedure | <ol style="list-style-type: none"> The transmitter was placed on a wooden turntable, and it was transmitting into a non-radiating load which was also placed on the turntable. The measurement antenna was placed at a distance of 3 meters from the EUT. During the tests, the antenna height and polarization as well as EUT azimuth were varied in order to identify the maximum level of emissions from the EUT. The test was performed by placing the EUT on 3-orthogonal axis. Remove the EUT and replace it with substitution antenna. A signal generator was connected to the substitution antenna by a non-radiating cable. The absolute levels of the spurious emissions were measured by the substitution. <p>Sample Calculation:</p> $\text{EUT Field Strength} = \text{Raw Amplitude (dB}\mu\text{V/m)} - \text{Amplifier Gain (dB)} + \text{Antenna Factor (dB)} + \text{Cable Loss (dB)} + \text{Filter Attenuation (dB, if used)}$ |
|----------------|---|

| | |
|-------------|-----------------|
| Test Report | 16071337-FCC-R1 |
| Page | 51 of 81 |

| | |
|--------|--|
| Remark | |
| Result | <input checked="" type="checkbox"/> Pass <input type="checkbox"/> Fail |

Test Data Yes N/A
Test Plot Yes (See below) N/A

Cellular Band (Part 22H) result

Low channel

| Frequency (MHz) | Substituted level (dBm) | Polarity (H/V) | Antenna Gain Correction (dB) | Cable Loss (dB) | Corrected Reading (dBm) | Limit (dBm) | Margin (dB) |
|-----------------|-------------------------|----------------|------------------------------|-----------------|-------------------------|-------------|-------------|
| 1648.4 | -43.84 | V | 7.95 | 0.78 | -36.67 | -13 | -23.67 |
| 1648.4 | -44.23 | H | 7.95 | 0.78 | -37.06 | -13 | -24.06 |
| 326.4 | -53.12 | V | 6.4 | 0.26 | -46.98 | -13 | -33.98 |
| 605.9 | -53.06 | H | 6.8 | 0.37 | -46.63 | -13 | -33.63 |

Middle channel

| Frequency (MHz) | Substituted level (dBm) | Polarity (H/V) | Antenna Gain Correction (dB) | Cable Loss (dB) | Corrected Reading (dBm) | Limit (dBm) | Margin (dB) |
|-----------------|-------------------------|----------------|------------------------------|-----------------|-------------------------|-------------|-------------|
| 1673.2 | -43.57 | V | 7.95 | 0.78 | -36.4 | -13 | -23.40 |
| 1673.2 | -44.26 | H | 7.95 | 0.78 | -37.09 | -13 | -24.09 |
| 328.5 | -52.89 | V | 6.4 | 0.26 | -46.75 | -13 | -33.75 |
| 604.2 | -52.79 | H | 6.8 | 0.37 | -46.36 | -13 | -33.36 |

High channel

| Frequency (MHz) | Substituted level (dBm) | Polarity (H/V) | Antenna Gain Correction (dB) | Cable Loss (dB) | Corrected Reading (dBm) | Limit (dBm) | Margin (dB) |
|-----------------|-------------------------|----------------|------------------------------|-----------------|-------------------------|-------------|-------------|
| 1697.6 | -43.58 | V | 7.95 | 0.78 | -36.41 | -13 | -23.41 |
| 1697.6 | -43.98 | H | 7.95 | 0.78 | -36.81 | -13 | -23.81 |
| 327.8 | -52.75 | V | 6.4 | 0.26 | -46.61 | -13 | -33.61 |
| 605.1 | -52.84 | H | 6.8 | 0.37 | -46.41 | -13 | -33.41 |

Note:

- 1, The testing has been conformed to $10 \times 848.8 \text{MHz} = 8,488 \text{MHz}$
- 2, All other emissions more than 30 dB below the limit
- 3, GSM voice, GPRS and EGPRS mode were investigated. The results above show only the worse cases
- 4, X-Axis, Y-Axis and Z-Axis were investigated. The results above show only the worst case.

PCS Band (Part24E) result

Low channel

| Frequency (MHz) | Substituted level (dBm) | Polarity (H/V) | Antenna Gain Correction (dB) | Cable Loss (dB) | Corrected Reading (dBm) | Limit (dBm) | Margin (dB) |
|-----------------|-------------------------|----------------|------------------------------|-----------------|-------------------------|-------------|-------------|
| 3700.4 | -48.94 | V | 10.25 | 2.73 | -41.42 | -13 | -28.42 |
| 3700.4 | -49.37 | H | 10.25 | 2.73 | -41.85 | -13 | -28.85 |
| 325.7 | -53.68 | V | 6.4 | 0.26 | -47.54 | -13 | -34.54 |
| 602.6 | -54.12 | H | 6.8 | 0.37 | -47.69 | -13 | -34.69 |

Middle channel

| Frequency (MHz) | Substituted level (dBm) | Polarity (H/V) | Antenna Gain Correction (dB) | Cable Loss (dB) | Corrected Reading (dBm) | Limit (dBm) | Margin (dB) |
|-----------------|-------------------------|----------------|------------------------------|-----------------|-------------------------|-------------|-------------|
| 3760 | -48.67 | V | 10.25 | 2.73 | -41.15 | -13 | -28.15 |
| 3760 | -49.38 | H | 10.25 | 2.73 | -41.86 | -13 | -28.86 |
| 326.4 | -53.46 | V | 6.4 | 0.26 | -47.32 | -13 | -34.32 |
| 603.8 | -54.11 | H | 6.8 | 0.37 | -47.68 | -13 | -34.68 |

High channel

| Frequency (MHz) | Substituted level (dBm) | Polarity (H/V) | Antenna Gain Correction (dB) | Cable Loss (dB) | Corrected Reading (dBm) | Limit (dBm) | Margin (dB) |
|-----------------|-------------------------|----------------|------------------------------|-----------------|-------------------------|-------------|-------------|
| 3819.6 | -48.76 | V | 10.36 | 2.73 | -41.13 | -13 | -28.13 |
| 3819.6 | -49.68 | H | 10.36 | 2.73 | -42.05 | -13 | -29.05 |
| 324.1 | -53.47 | V | 6.4 | 0.26 | -47.33 | -13 | -34.33 |
| 601.3 | -52.31 | H | 6.8 | 0.37 | -45.88 | -13 | -32.88 |

Note:

- 1, The testing has been conformed to $10 \times 1909.8 \text{ MHz} = 19,098 \text{ MHz}$
- 2, All other emissions more than 30 dB below the limit
- 3, GSM voice, GPRS and EGPRS mode were investigated. The results above show only the worse cases
- 4, X-Axis, Y-Axis and Z-Axis were investigated. The results above show only the worst case.

UMTS-FDD Band V (Part 22H)

Low channel

| Frequency (MHz) | Substituted level (dBm) | Polarity (H/V) | Antenna Gain Correction (dB) | Cable Loss (dB) | Corrected Reading (dBm) | Limit (dBm) | Margin (dB) |
|-----------------|-------------------------|----------------|------------------------------|-----------------|-------------------------|-------------|-------------|
| 1652.8 | -46.29 | V | 7.95 | 0.78 | -39.12 | -13 | -26.12 |
| 1652.8 | -46.31 | H | 7.95 | 0.78 | -39.14 | -13 | -26.14 |
| 329.5 | -53.11 | V | 6.4 | 0.26 | -46.97 | -13 | -33.97 |
| 606.7 | -53.26 | H | 6.8 | 0.37 | -46.83 | -13 | -33.83 |

Middle channel

| Frequency (MHz) | Substituted level (dBm) | Polarity (H/V) | Antenna Gain Correction (dB) | Cable Loss (dB) | Corrected Reading (dBm) | Limit (dBm) | Margin (dB) |
|-----------------|-------------------------|----------------|------------------------------|-----------------|-------------------------|-------------|-------------|
| 1670 | -46.67 | V | 7.95 | 0.78 | -39.5 | -13 | -26.50 |
| 1670 | -45.82 | H | 7.95 | 0.78 | -38.65 | -13 | -25.65 |
| 327.8 | -52.64 | V | 6.4 | 0.26 | -46.5 | -13 | -33.50 |
| 604.3 | -53.69 | H | 6.8 | 0.37 | -47.26 | -13 | -34.26 |

High channel

| Frequency (MHz) | Substituted level (dBm) | Polarity (H/V) | Antenna Gain Correction (dB) | Cable Loss (dB) | Corrected Reading (dBm) | Limit (dBm) | Margin (dB) |
|-----------------|-------------------------|----------------|------------------------------|-----------------|-------------------------|-------------|-------------|
| 1693.2 | -46.58 | V | 7.95 | 0.78 | -39.41 | -13 | -26.41 |
| 1693.2 | -45.69 | H | 7.95 | 0.78 | -38.52 | -13 | -25.52 |
| 326.8 | -52.73 | V | 6.4 | 0.26 | -46.59 | -13 | -33.59 |
| 603.4 | -53.16 | H | 6.8 | 0.37 | -46.73 | -13 | -33.73 |

Note:

- 1, The testing has been conformed to $10 \times 846.6 \text{ MHz} = 8,466 \text{ MHz}$
- 2, All other emissions more than 30 dB below the limit
- 3, RMC, HSUPA and HSDPA mode were investigated. The results above show only the worse cases
- 4, X-Axis, Y-Axis and Z-Axis were investigated. The results above show only the worst case.

UMTS-FDD Band II (Part 24E)

Low channel

| Frequency (MHz) | Substituted level (dBm) | Polarity (H/V) | Antenna Gain Correction (dB) | Cable Loss (dB) | Corrected Reading (dBm) | Limit (dBm) | Margin (dB) |
|-----------------|-------------------------|----------------|------------------------------|-----------------|-------------------------|-------------|-------------|
| 3704.8 | -49.57 | V | 10.25 | 2.73 | -42.05 | -13 | -29.05 |
| 3704.8 | -50.24 | H | 10.25 | 2.73 | -42.72 | -13 | -29.72 |
| 330.4 | -53.66 | V | 6.4 | 0.26 | -47.52 | -13 | -34.52 |
| 605.8 | -53.48 | H | 6.8 | 0.37 | -47.05 | -13 | -34.05 |

Middle channel

| Frequency (MHz) | Substituted level (dBm) | Polarity (H/V) | Antenna Gain Correction (dB) | Cable Loss (dB) | Corrected Reading (dBm) | Limit (dBm) | Margin (dB) |
|-----------------|-------------------------|----------------|------------------------------|-----------------|-------------------------|-------------|-------------|
| 3760 | -49.58 | V | 10.25 | 2.73 | -42.06 | -13 | -29.06 |
| 3760 | -49.81 | H | 10.25 | 2.73 | -42.29 | -13 | -29.29 |
| 331.5 | -53.67 | V | 6.4 | 0.26 | -47.53 | -13 | -34.53 |
| 599.7 | -53.44 | H | 6.8 | 0.37 | -47.01 | -13 | -34.01 |

High channel

| Frequency (MHz) | Substituted level (dBm) | Polarity (H/V) | Antenna Gain Correction (dB) | Cable Loss (dB) | Corrected Reading (dBm) | Limit (dBm) | Margin (dB) |
|-----------------|-------------------------|----------------|------------------------------|-----------------|-------------------------|-------------|-------------|
| 3815.2 | -49.55 | V | 10.36 | 2.73 | -41.92 | -13 | -28.92 |
| 3815.2 | -49.67 | H | 10.36 | 2.73 | -42.04 | -13 | -29.04 |
| 324.5 | -53.46 | V | 6.4 | 0.26 | -47.32 | -13 | -34.32 |
| 608.9 | -54.28 | H | 6.8 | 0.37 | -47.85 | -13 | -34.85 |

Note:

1, The testing has been conformed to $10 \times 1907.6 \text{ MHz} = 19,076 \text{ MHz}$

2, All other emissions more than 30 dB below the limit

3, RMC, HSUPA and HSDPA mode were investigated. The results above show only the worse cases

4, X-Axis, Y-Axis and Z-Axis were investigated. The results above show only the worst case

6.7 Band Edge

| | |
|----------------------|----------------------|
| Temperature | 25°C |
| Relative Humidity | 52% |
| Atmospheric Pressure | 1028mbar |
| Test date : | November 28&29, 2016 |
| Tested By : | Loren Luo |

Requirement(s):

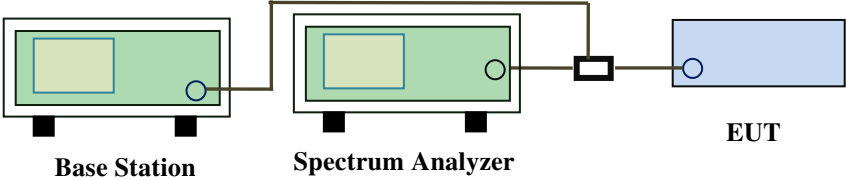
| Spec | Item | Requirement | Applicable |
|--------------------------|--|--|-------------------------------------|
| §22.917(a) §24.238(a) | a) | The power of any emission outside of the authorized operating frequency ranges must be lower than the transmitter power (P) by a factor of at least $43 + 10 \log (P)$ dB. | <input checked="" type="checkbox"/> |
| Test setup |  <p>The diagram illustrates the test setup. On the left is a green box labeled 'Base Station'. In the middle is a green box labeled 'Spectrum Analyzer'. On the right is a blue box labeled 'EUT'. A power divider is connected between the Spectrum Analyzer and the EUT. The Base Station is connected to the Spectrum Analyzer.</p> | | |
| Procedure | <ul style="list-style-type: none"> - The EUT was connected to Spectrum Analyzer and Base Station via power divider. - The Band Edges of low and high channels for the highest RF powers were measured. Setting RBW as roughly BW/100. | | |
| Remark | | | |
| Result | <input checked="" type="checkbox"/> Pass <input type="checkbox"/> Fail | | |

Test Data Yes N/A
 Test Plot Yes (See below) N/A

GSM Voice:

Cellular Band (Part 22H) result

| Frequency (MHz) | Emission (dBm) | Limit (dBm) |
|-----------------|----------------|-------------|
| 823.9975 | -14.61 | -13 |
| 849.0025 | -14.11 | -13 |

PCS Band (Part24E) result

| Frequency (MHz) | Emission (dBm) | Limit (dBm) |
|-----------------|----------------|-------------|
| 1849.9975 | -15.60 | -13 |
| 1910.0225 | -17.20 | -13 |

GPRS:

Cellular Band (Part 22H) result

| Frequency (MHz) | Emission (dBm) | Limit (dBm) |
|-----------------|----------------|-------------|
| 823.9800 | -14.80 | -13 |
| 849.0200 | -14.10 | -13 |

PCS Band (Part24E) result

| Frequency (MHz) | Emission (dBm) | Limit (dBm) |
|-----------------|----------------|-------------|
| 1849.9975 | -14.90 | -13 |
| 1910.0250 | -16.27 | -13 |

EGPRS (MCS5):

Cellular Band (Part 22H) result

| Frequency (MHz) | Emission (dBm) | Limit (dBm) |
|-----------------|----------------|-------------|
| 823.9989 | -14.67 | -13 |
| 849.0025 | -13.77 | -13 |

PCS Band (Part24E) result

| Frequency (MHz) | Emission (dBm) | Limit (dBm) |
|-----------------|----------------|-------------|
| 1849.9975 | -15.27 | -13 |
| 1910.0200 | -17.40 | -13 |

RMC:

UMTS-FDD Band V (Part 22H)

| Frequency (MHz) | Emission (dBm) | Limit (dBm) |
|-----------------|----------------|-------------|
| 824.000 | -27.34 | -13 |
| 849.275 | -28.10 | -13 |

UMTS-FDD Band II (Part 24E)

| Frequency (MHz) | Emission (dBm) | Limit (dBm) |
|-----------------|----------------|-------------|
| 1849.925 | -22.64 | -13 |
| 1910.075 | -24.15 | -13 |

HSDPA:

UMTS-FDD Band V (Part 22H)

| Frequency (MHz) | Emission (dBm) | Limit (dBm) |
|-----------------|----------------|-------------|
| 823.550 | -25.25 | -13 |
| 849.200 | -28.27 | -13 |

UMTS-FDD Band II (Part 24E)

| Frequency (MHz) | Emission (dBm) | Limit (dBm) |
|-----------------|----------------|-------------|
| 1849.900 | -23.70 | -13 |
| 1910.050 | -27.16 | -13 |

HSUPA:

UMTS-FDD Band V (Part 22H)

| Frequency (MHz) | Emission (dBm) | Limit (dBm) |
|-----------------|----------------|-------------|
| 823.825 | -26.38 | -13 |
| 849.875 | -26.90 | -13 |

UMTS-FDD Band II (Part 24E)

| Frequency (MHz) | Emission (dBm) | Limit (dBm) |
|-----------------|----------------|-------------|
| 1849.925 | -22.95 | -13 |
| 1910.025 | -18.61 | -13 |

GPRS:

Test Plots

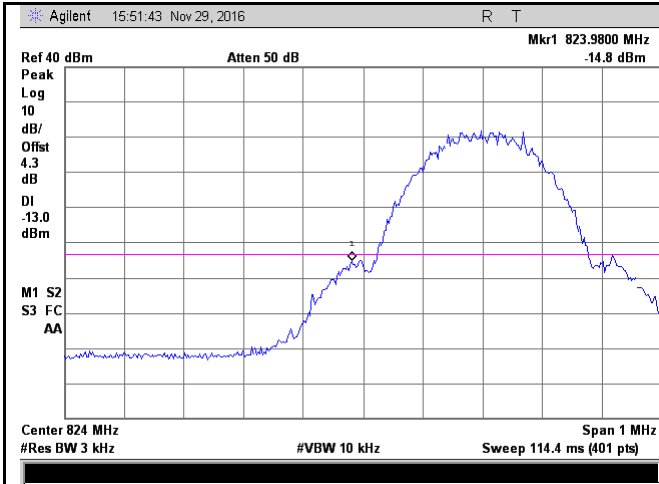

Cellular Band - Low Channel

Note: Offset=Cable loss (4.0) + 10log
 (3.22/3)=4.0+0.3=4.3dB

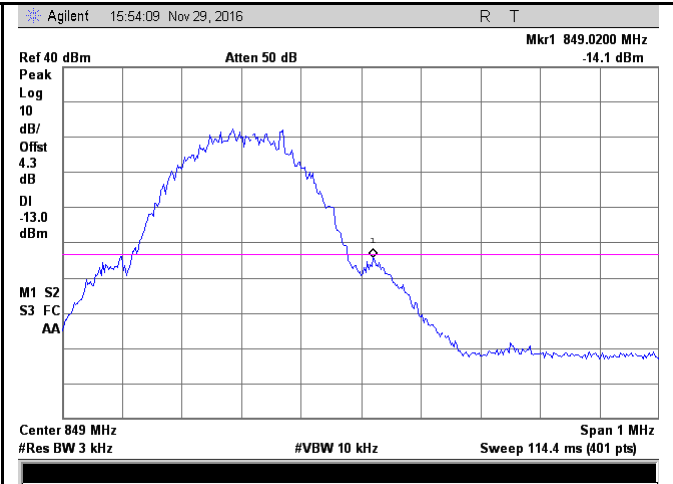

Cellular Band - High Channel

Note: Offset=Cable loss (4.0) + 10log
 (3.22/3)=4.0+0.3=4.3dB

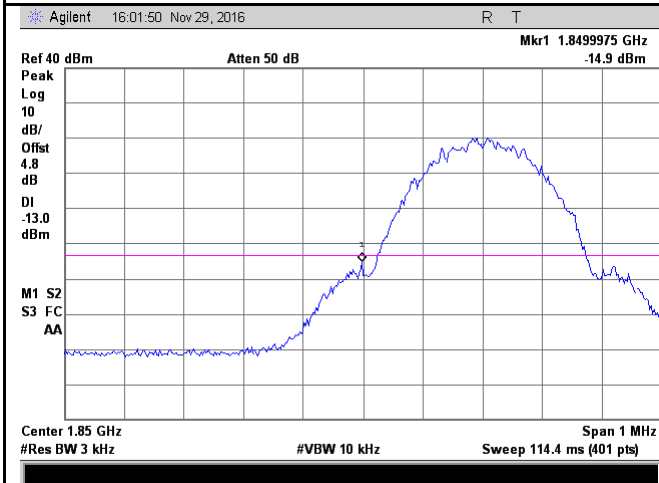

PCS Band - Low Channel

Note: Offset=Cable loss (4.5) + 10log
 (3.21/3)=4.5+0.3=4.8dB

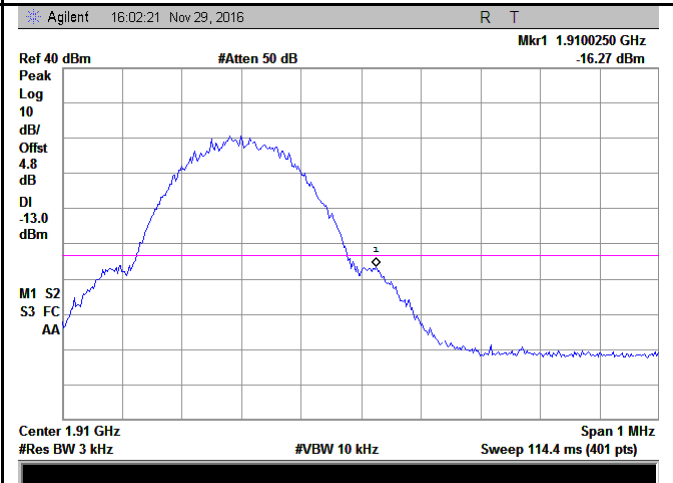

PCS Band - High Channel

Note: Offset=Cable loss (4.5) + 10log
 (3.19/3)=4.5+0.3=4.8dB

EGPRS (MCS5):

Test Plots

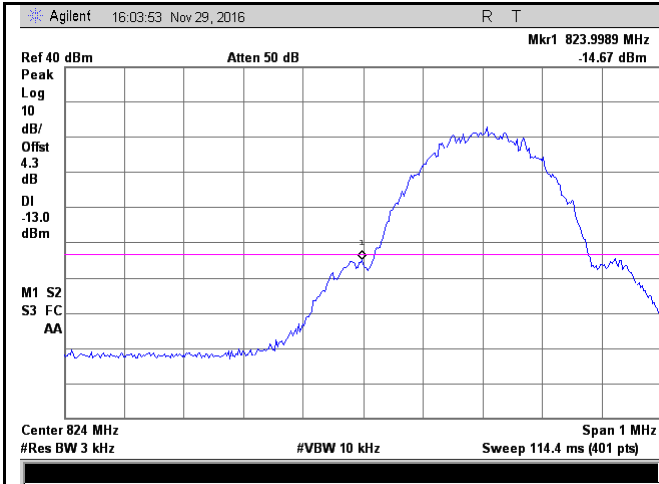

Cellular Band - Low Channel

Note: Offset=Cable loss (4.0) + 10log
(3.17/3)=4.0+0.4=4.9dB

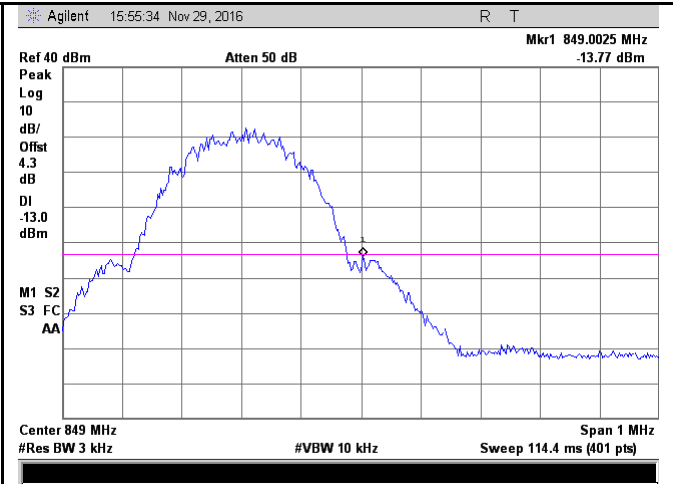

Cellular Band - High Channel

Note: Offset=Cable loss (4.0) + 10log
(3.18/3)=4.0+0.3=4.3dB

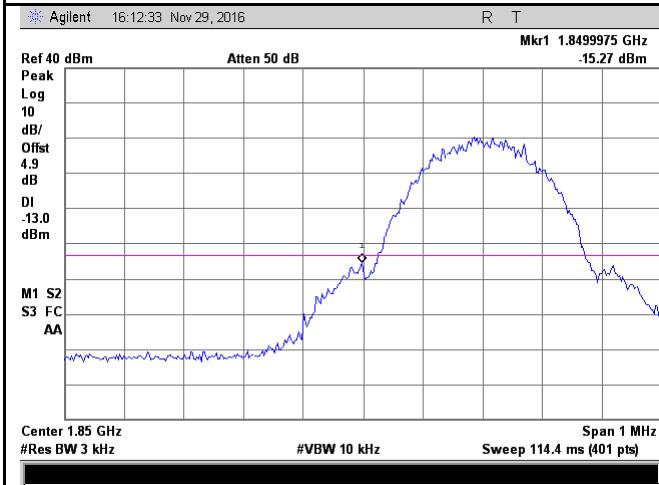

PCS Band - Low Channel

Note: Offset=Cable loss (4.5) + 10log
(3.27/3)=4.5+0.4=4.9dB

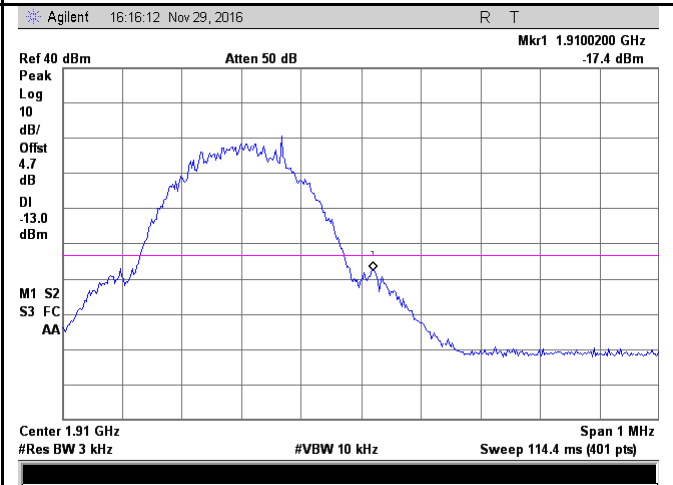

PCS Band - High Channel

Note: Offset=Cable loss (4.5) + 10log
(3.12/3)=4.5+0.2=4.7dB

RMC:

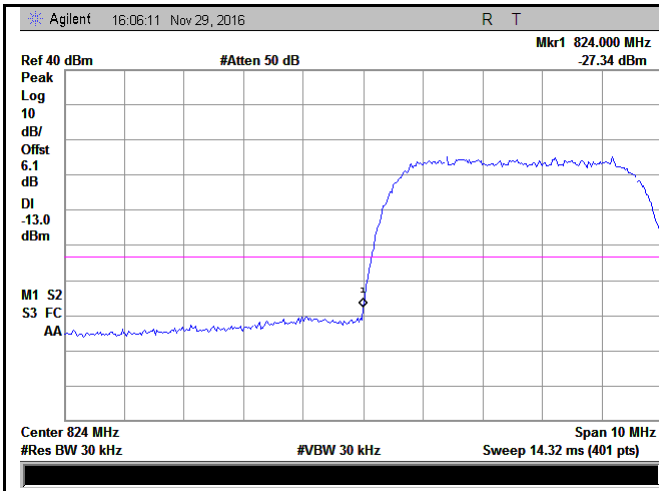

UMTS-FDD Band V - Low Channel

Note: Offset=Cable loss (4.0) + 10log
 (47.04/30)=4.0+2.1=6.1 dB

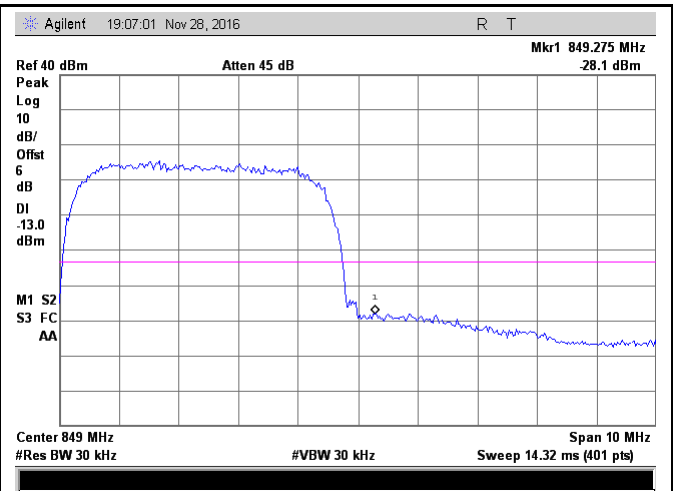

UMTS-FDD Band V - High Channel

Note: Offset=Cable loss (4.0) + 10log
 (47.03/30)=4.0+2.0=6.0 dB

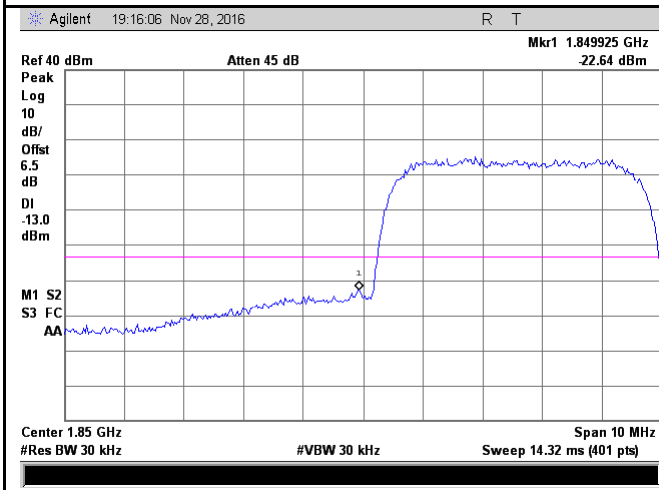

UMTS-FDD Band II - Low Channel

Note: Offset=Cable loss (4.5) + 10log
 (47.09/30)=4.5+2.0=6.5 dB

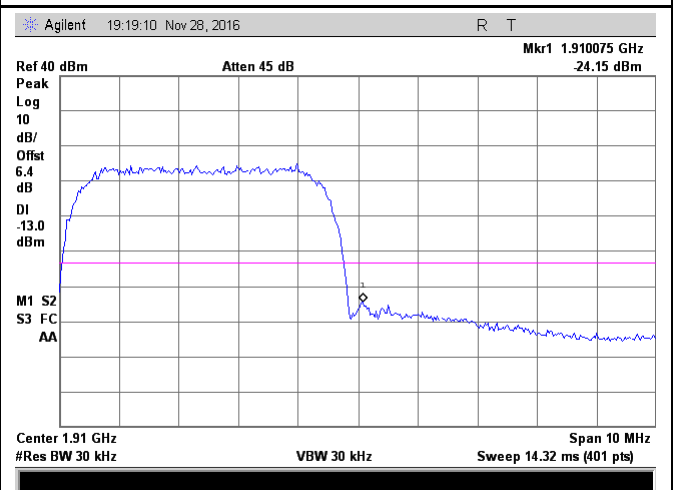

UMTS-FDD Band II - High Channel

Note: Offset=Cable loss (4.5) + 10log
 (46.95/30)=4.5+1.9=6.4 dB

HSDPA:

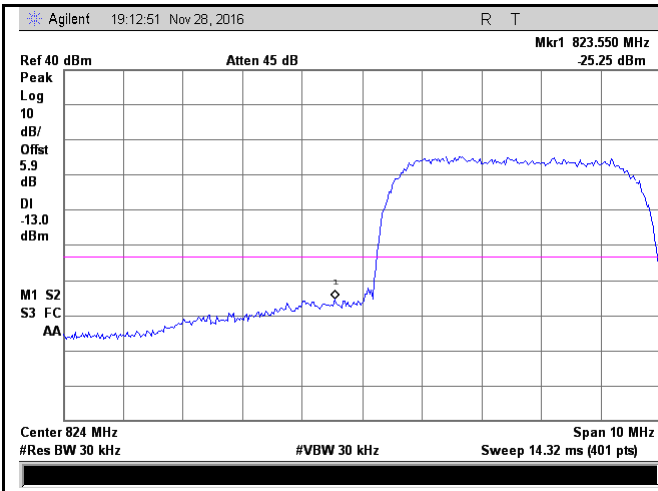

UMTS-FDD Band V - Low Channel

Note: Offset=Cable loss (4.0) + 10log
 (46.90/30)=4.0+1.9=5.9 dB

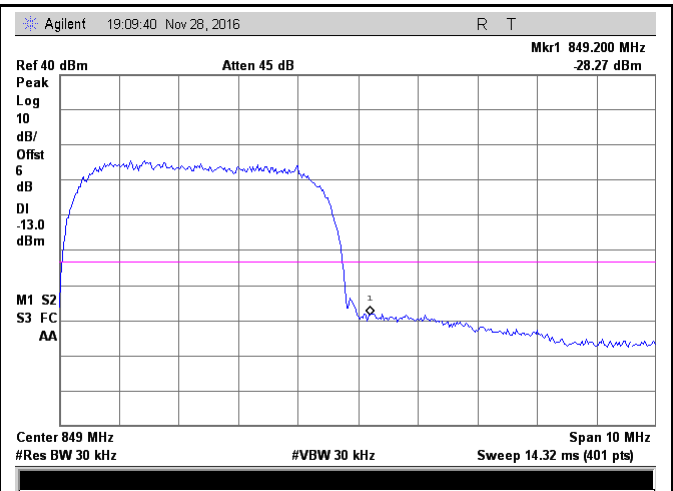

UMTS-FDD Band V - High Channel

Note: Offset=Cable loss (4.0) + 10log
 (47.07/30)=4.0+2.0=6.0 dB

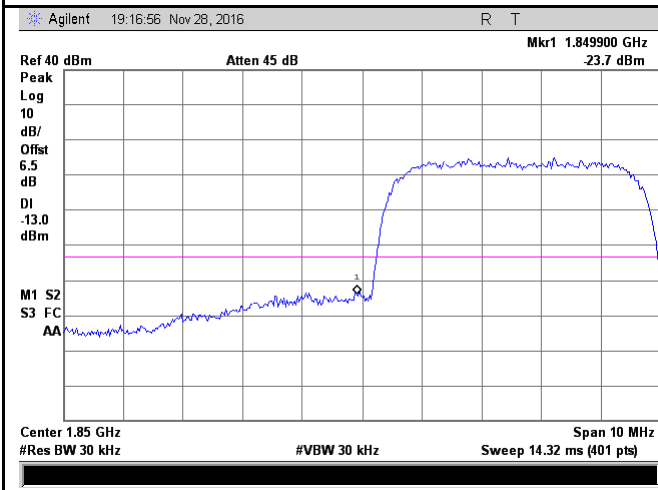

UMTS-FDD Band II - Low Channel

Note: Offset=Cable loss (4.5) + 10log
 (47.07/30)=4.0+2.0=6.5 dB

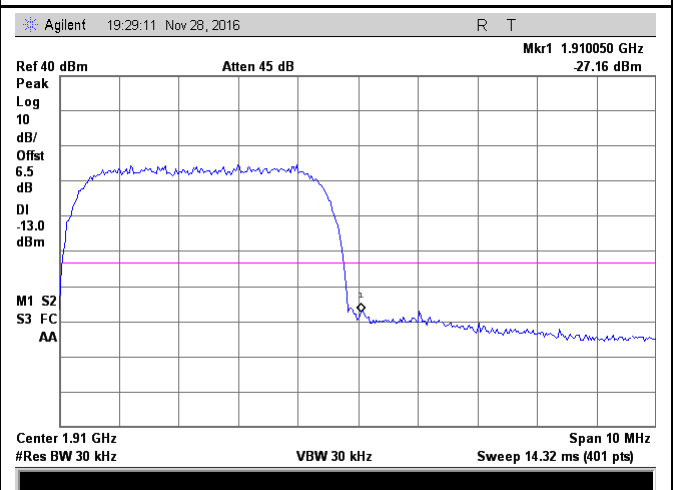

UMTS-FDD Band II - High Channel

Note: Offset=Cable loss (4.5) + 10log
 (47.24/30)=4.0+2.0=6.5 dB

HSUPA:

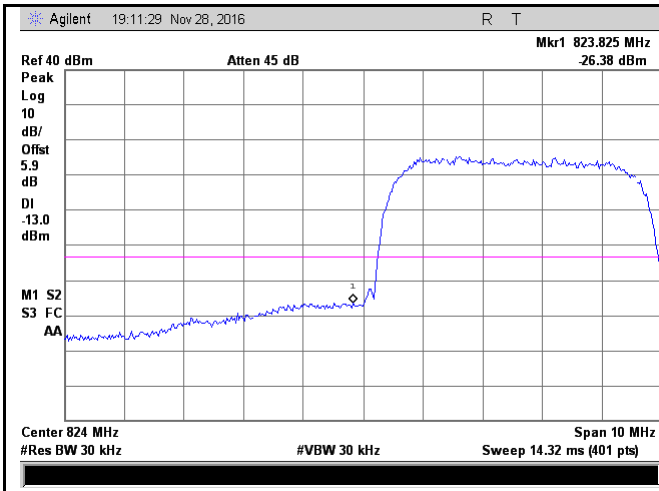

UMTS-FDD Band V - Low Channel

Note: Offset=Cable loss (4.0) + 10log
 (46.75/30)=4.0+1.9=5.9 dB

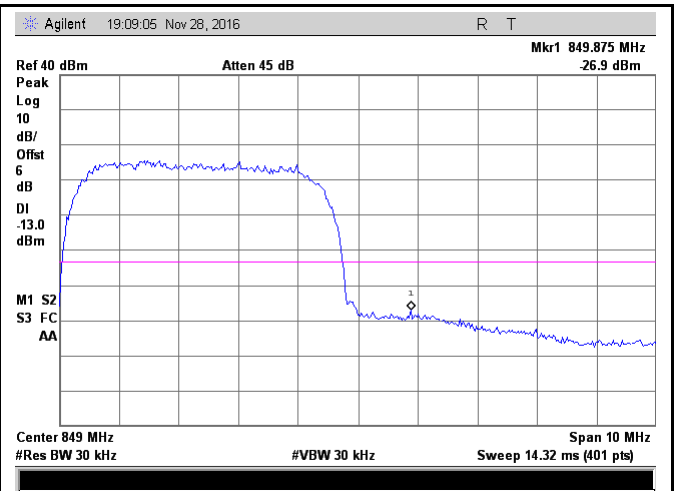

UMTS-FDD Band V - High Channel

Note: Offset=Cable loss (4.0) + 10log
 (47.04/30)=4.0+2.0=6.0 dB

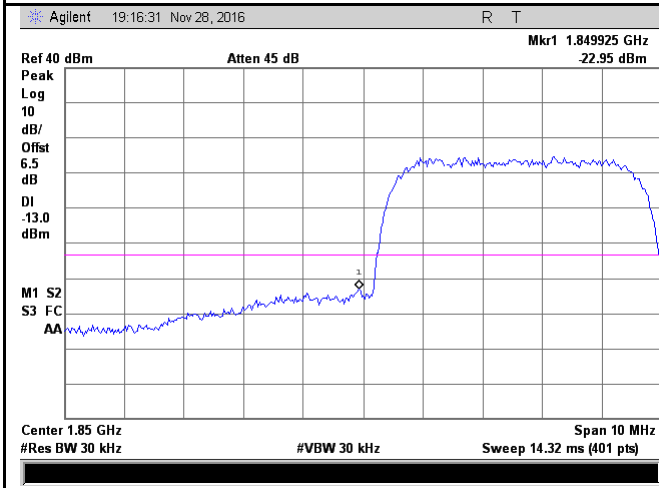

UMTS-FDD Band II - Low Channel

Note: Offset=Cable loss (4.5) + 10log
 (47.43/30)=4.5+2.0=6.5dB

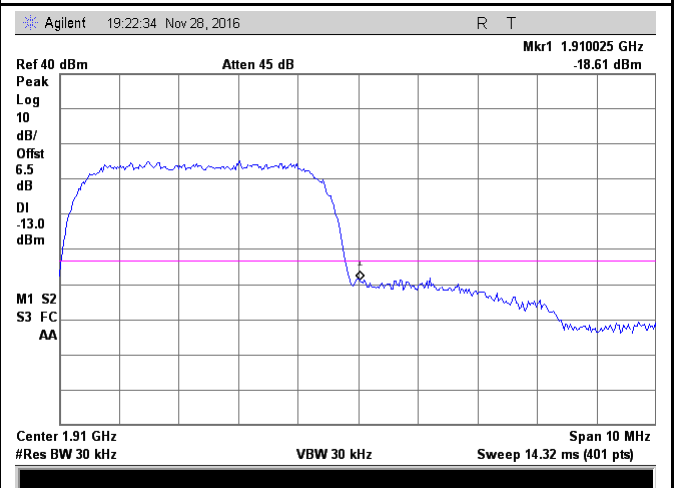

UMTS-FDD Band II - High Channel

Note: Offset=Cable loss (4.5) + 10log
 (47.31/30)=4.5+2.0=6.5 dB

6.8 Frequency Stability

| | |
|----------------------|-------------------|
| Temperature | 25°C |
| Relative Humidity | 52% |
| Atmospheric Pressure | 1028mbar |
| Test date : | November 28, 2016 |
| Tested By : | Loren Luo |

Requirement(s):

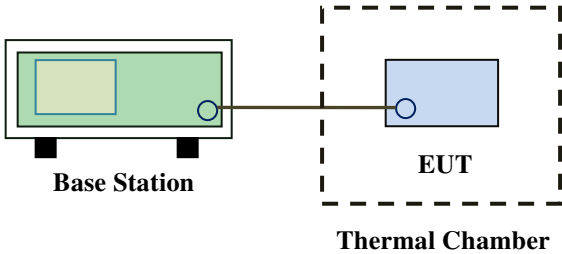
| Spec | Item | Requirement | Applicable | | | | | | | | | | | | | | | | | | | | | | | | | | | | | | | | |
|----------------------------------|---|---|-----------------------|------------------------|------------------------|------------------------|----------|------|------|------|-----------|-----|-----|------|------------|-----|-----|----|------------|-----|-----|-----|------------|-----|-----|-----|------------|-----|-----|-----|--------------|------|-----|-----|-------------------------------------|
| §2.1055, §22.355 & §24.235 | a) | <p>According to §22.355, the carrier frequency of each transmitter in the Public Mobile Services must be maintained within the tolerances given in Table below:</p> <p>Frequency Tolerance for Transmitters in the Public Mobile Services</p> <table border="1"> <thead> <tr> <th>Frequency Range (MHz)</th> <th>Base, fixed (ppm)</th> <th>Mobile ≤ 3 watts (ppm)</th> <th>Mobile ≤ 3 watts (ppm)</th> </tr> </thead> <tbody> <tr> <td>25 to 50</td> <td>20.0</td> <td>20.0</td> <td>50.0</td> </tr> <tr> <td>50 to 450</td> <td>5.0</td> <td>5.0</td> <td>50.0</td> </tr> <tr> <td>450 to 512</td> <td>2.5</td> <td>5.0</td> <td>10</td> </tr> <tr> <td>821 to 896</td> <td>1.5</td> <td>2.5</td> <td>2.5</td> </tr> <tr> <td>928 to 929</td> <td>5.0</td> <td>N/A</td> <td>N/A</td> </tr> <tr> <td>929 to 960</td> <td>1.5</td> <td>N/A</td> <td>N/A</td> </tr> <tr> <td>2110 to 2220</td> <td>10.0</td> <td>N/A</td> <td>N/A</td> </tr> </tbody> </table> <p>According to §24.235, the frequency stability shall be sufficient to ensure that the fundamental emissions stay within the authorized frequency block.</p> | Frequency Range (MHz) | Base, fixed (ppm) | Mobile ≤ 3 watts (ppm) | Mobile ≤ 3 watts (ppm) | 25 to 50 | 20.0 | 20.0 | 50.0 | 50 to 450 | 5.0 | 5.0 | 50.0 | 450 to 512 | 2.5 | 5.0 | 10 | 821 to 896 | 1.5 | 2.5 | 2.5 | 928 to 929 | 5.0 | N/A | N/A | 929 to 960 | 1.5 | N/A | N/A | 2110 to 2220 | 10.0 | N/A | N/A | <input checked="" type="checkbox"/> |
| | | Frequency Range (MHz) | Base, fixed (ppm) | Mobile ≤ 3 watts (ppm) | Mobile ≤ 3 watts (ppm) | | | | | | | | | | | | | | | | | | | | | | | | | | | | | | |
| | | 25 to 50 | 20.0 | 20.0 | 50.0 | | | | | | | | | | | | | | | | | | | | | | | | | | | | | | |
| | | 50 to 450 | 5.0 | 5.0 | 50.0 | | | | | | | | | | | | | | | | | | | | | | | | | | | | | | |
| | | 450 to 512 | 2.5 | 5.0 | 10 | | | | | | | | | | | | | | | | | | | | | | | | | | | | | | |
| | | 821 to 896 | 1.5 | 2.5 | 2.5 | | | | | | | | | | | | | | | | | | | | | | | | | | | | | | |
| | | 928 to 929 | 5.0 | N/A | N/A | | | | | | | | | | | | | | | | | | | | | | | | | | | | | | |
| | | 929 to 960 | 1.5 | N/A | N/A | | | | | | | | | | | | | | | | | | | | | | | | | | | | | | |
| 2110 to 2220 | 10.0 | N/A | N/A | | | | | | | | | | | | | | | | | | | | | | | | | | | | | | | | |
| Test setup |  <p>The diagram illustrates the test setup. On the left, a green rectangular box represents the 'Base Station'. A line connects it to a blue rectangular box labeled 'EUT' (Equipment Under Test), which is enclosed within a dashed-line box representing the 'Thermal Chamber'.</p> | | | | | | | | | | | | | | | | | | | | | | | | | | | | | | | | | | |

| | |
|-------------|-----------------|
| Test Report | 16071337-FCC-R1 |
| Page | 67 of 81 |

| | |
|-----------|---|
| Procedure | <p>A communication link was established between EUT and base station. The frequency error was monitored and measured by base station under variation of ambient temperature and variation of primary supply voltage.</p> <p>Limit: The frequency stability of the transmitter shall be maintained within $\pm 0.00025\%$ ($\pm 2.5\text{ppm}$) of the center frequency.</p> |
| Remark | |
| Result | <input checked="" type="checkbox"/> Pass <input type="checkbox"/> Fail |

Test Data Yes N/A

Test Plot Yes (See below) N/A

GSM Voice:

Cellular Band (Part 22H) result

| Middle Channel, $f_0 = 836.6$ MHz | | | | |
|-----------------------------------|-----------------------------------|----------------------|-----------------------|-------------|
| Temperature (°C) | Power Supplied (V _{DC}) | Frequency Error (Hz) | Frequency Error (ppm) | Limit (ppm) |
| -10 | 3.7 | 15 | 0.0179 | 2.5 |
| 0 | | 16 | 0.0191 | 2.5 |
| 10 | | 14 | 0.0167 | 2.5 |
| 20 | | 18 | 0.0215 | 2.5 |
| 30 | | 14 | 0.0167 | 2.5 |
| 40 | | 13 | 0.0155 | 2.5 |
| 50 | | 13 | 0.0155 | 2.5 |
| 55 | | 15 | 0.0179 | 2.5 |
| 25 | 4.2 | 19 | 0.0227 | 2.5 |
| | 3.5 | 12 | 0.0143 | 2.5 |

PCS Band (Part 24E) result

| Middle Channel, $f_0 = 1880$ MHz | | | | |
|----------------------------------|-----------------------------------|----------------------|-----------------------|-------------|
| Temperature (°C) | Power Supplied (V _{DC}) | Frequency Error (Hz) | Frequency Error (ppm) | Limit (ppm) |
| -10 | 3.7 | 18 | 0.0096 | 2.5 |
| 0 | | 17 | 0.0090 | 2.5 |
| 10 | | 16 | 0.0085 | 2.5 |
| 20 | | 18 | 0.0096 | 2.5 |
| 30 | | 19 | 0.0101 | 2.5 |
| 40 | | 15 | 0.0080 | 2.5 |
| 50 | | 18 | 0.0096 | 2.5 |
| 55 | | 13 | 0.0069 | 2.5 |
| 25 | 4.2 | 14 | 0.0074 | 2.5 |
| | 3.5 | 17 | 0.0090 | 2.5 |

RMC:

UMTS-FDD Band V (Part 22H)

| Middle Channel, $f_0 = 835$ MHz | | | | |
|---------------------------------|-----------------------------------|----------------------|-----------------------|-------------|
| Temperature (°C) | Power Supplied (V _{DC}) | Frequency Error (Hz) | Frequency Error (ppm) | Limit (ppm) |
| -10 | 3.7 | 16 | 0.0192 | 2.5 |
| 0 | | 14 | 0.0168 | 2.5 |
| 10 | | 19 | 0.0228 | 2.5 |
| 20 | | 15 | 0.0180 | 2.5 |
| 30 | | 12 | 0.0144 | 2.5 |
| 40 | | 18 | 0.0216 | 2.5 |
| 50 | | 14 | 0.0168 | 2.5 |
| 55 | | 19 | 0.0228 | 2.5 |
| 25 | 4.2 | 15 | 0.0180 | 2.5 |
| | 3.5 | 14 | 0.0168 | 2.5 |

UMTS-FDD Band II (Part 24E)

| Middle Channel, $f_0 = 1880$ MHz | | | | |
|----------------------------------|-----------------------------------|----------------------|-----------------------|-------------|
| Temperature (°C) | Power Supplied (V _{DC}) | Frequency Error (Hz) | Frequency Error (ppm) | Limit (ppm) |
| -10 | 3.7 | 15 | 0.0080 | 2.5 |
| 0 | | 16 | 0.0085 | 2.5 |
| 10 | | 19 | 0.0101 | 2.5 |
| 20 | | 15 | 0.0080 | 2.5 |
| 30 | | 14 | 0.0074 | 2.5 |
| 40 | | 13 | 0.0069 | 2.5 |
| 50 | | 16 | 0.0085 | 2.5 |
| 55 | | 14 | 0.0074 | 2.5 |
| 25 | 4.2 | 14 | 0.0074 | 2.5 |
| | 3.5 | 18 | 0.0096 | 2.5 |

Annex A. TEST INSTRUMENT

| Instrument | Model | Serial # | Cal Date | Cal Due | In use |
|--|-------------------|------------|------------|------------|-------------------------------------|
| RF Conducted Test | | | | | |
| Agilent ESA-E SERIES SPECTRUM ANALYZER | E4407B | MY45108319 | 09/15/2016 | 09/14/2017 | <input checked="" type="checkbox"/> |
| Power Splitter | 1# | 1# | 08/31/2016 | 08/30/2017 | <input checked="" type="checkbox"/> |
| Universal Radio Communication Tester | CMU200 | 121393 | 09/24/2016 | 09/23/2017 | <input checked="" type="checkbox"/> |
| Temperature/Humidity Chamber | UHL-270 | 001 | 10/08/2016 | 10/07/2017 | <input checked="" type="checkbox"/> |
| DC Power Supply | E3640A | MY40004013 | 09/16/2016 | 09/15/2017 | <input checked="" type="checkbox"/> |
| RF Power Sensor | Dare RPR3006C/P/W | AY554013 | 09/16/2016 | 09/15/2017 | <input checked="" type="checkbox"/> |
| Radiated Emissions | | | | | |
| EMI test receiver | ESL6 | 100262 | 09/16/2016 | 09/15/2017 | <input checked="" type="checkbox"/> |
| OPT 010 AMPLIFIER (0.1-1300MHz) | 8447E | 2727A02430 | 08/31/2016 | 08/30/2017 | <input checked="" type="checkbox"/> |
| Microwave Preamplifier (1 ~ 26.5GHz) | 8449B | 3008A02402 | 03/24/2016 | 03/23/2017 | <input checked="" type="checkbox"/> |
| Bilog Antenna (30MHz~6GHz) | JB6 | A110712 | 09/20/2016 | 09/19/2017 | <input checked="" type="checkbox"/> |
| Bilog Antenna (30MHz~2GHz) | JB1 | A112017 | 09/20/2016 | 09/19/2017 | <input checked="" type="checkbox"/> |
| Double Ridge Horn Antenna (1 ~18GHz) | AH-118 | 71259 | 09/23/2016 | 09/22/2017 | <input checked="" type="checkbox"/> |
| Double Ridge Horn Antenna (1 ~18GHz) | AH-118 | 71283 | 09/23/2016 | 09/22/2017 | <input checked="" type="checkbox"/> |
| SYNTHESIZED SIGNAL GENERATOR | 8665B | 3744A01293 | 09/16/2016 | 09/15/2017 | <input checked="" type="checkbox"/> |
| Power Amplifier | SMC150D | R1553-0313 | 03/09/2016 | 03/08/2017 | <input checked="" type="checkbox"/> |
| Power Amplifier | S41-25D | R1553-0314 | 05/27/2016 | 05/26/2017 | <input checked="" type="checkbox"/> |
| Tunable Notch Filter | 3NF-800/1000-S | AA4 | 08/31/2016 | 08/30/2017 | <input checked="" type="checkbox"/> |

| | |
|-------------|-----------------|
| Test Report | 16071337-FCC-R1 |
| Page | 71 of 81 |

| | | | | | |
|----------------------|---------------------|------|------------|------------|-------------------------------------|
| Tunable Notch Filter | 3NF- 1000/2000-S | AM 4 | 08/31/2016 | 08/30/2017 | <input checked="" type="checkbox"/> |
|----------------------|---------------------|------|------------|------------|-------------------------------------|

Annex B. EUT And Test Setup Photographs

Annex B.i. Photograph: EUT External Photo



Whole Package View



Adapter - Front View



EUT - Front View



EUT - Rear View



EUT - Top View



EUT - Bottom View



EUT - Left View



EUT - Right View

Annex B.ii. Photograph: EUT Internal Photo



Cover Off - Top View 1



Cover Off - Top View 2



Battery - Front View



Battery - Rear View

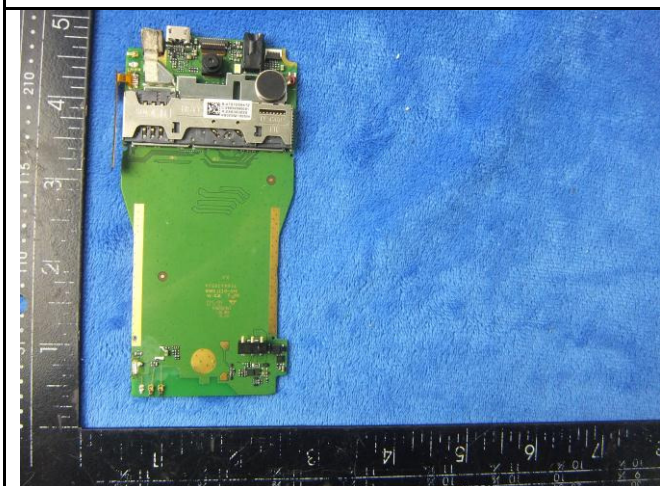

Mainboard with Shielding - Front View

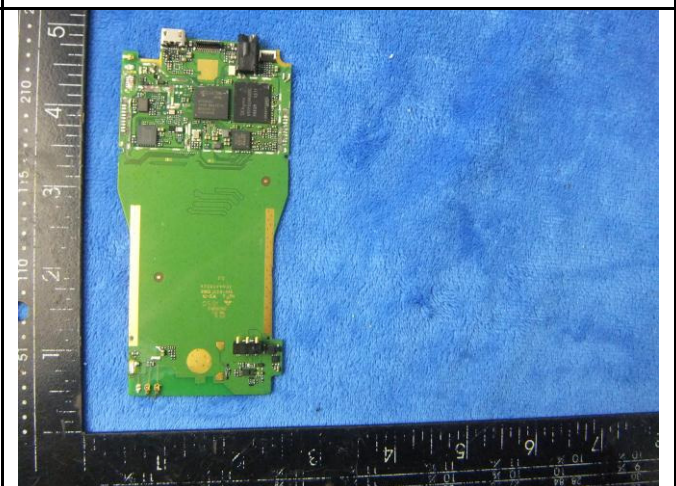

Mainboard without Shielding - Front View

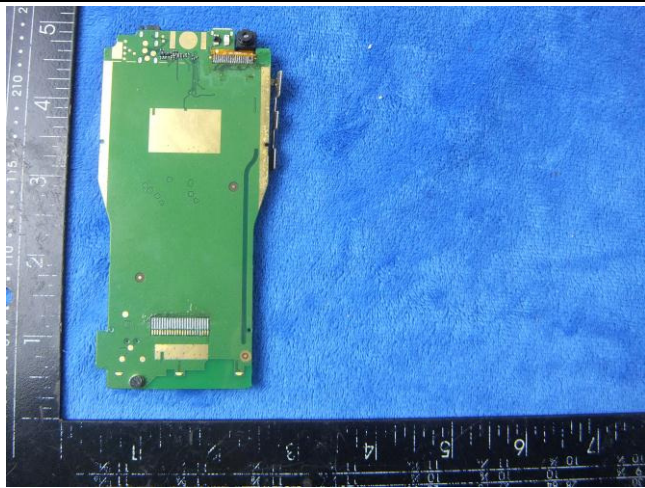

Mainboard - Rear View

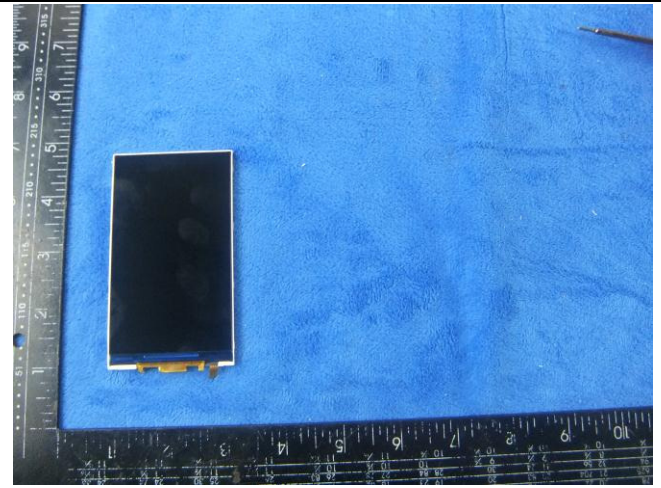

LCD - Front View

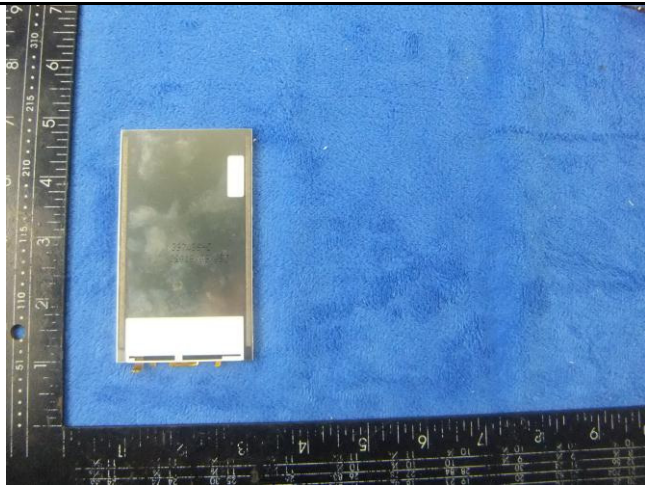

LCD - Rear View



GSM/PCS/UMTS-FDD Antenna View



WIFI/BT/BLE - Antenna View

Annex B.iii. Photograph: Test Setup Photo

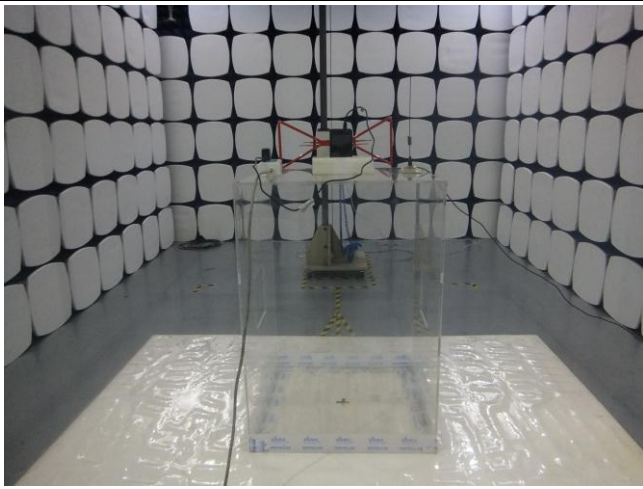

Radiated Spurious Emissions Test Setup Below 1GHz

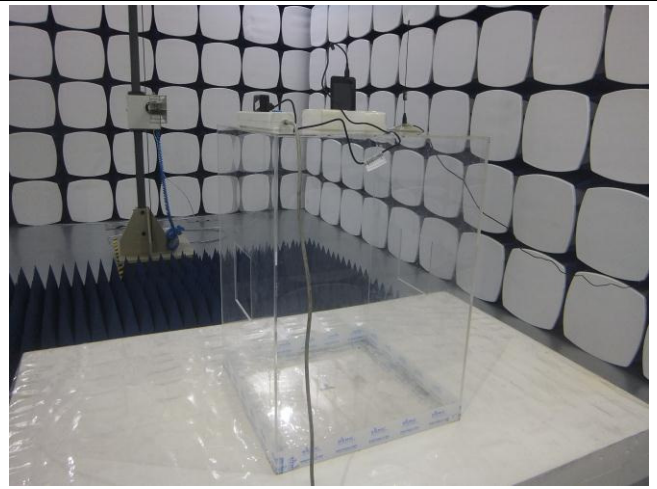

Radiated Spurious Emissions Test Setup Above
1GHz

Annex C. TEST SETUP AND SUPPORTING EQUIPMENT

Annex C.ii. TEST SET UP BLOCK

Block Configuration Diagram for Radiated Emissions

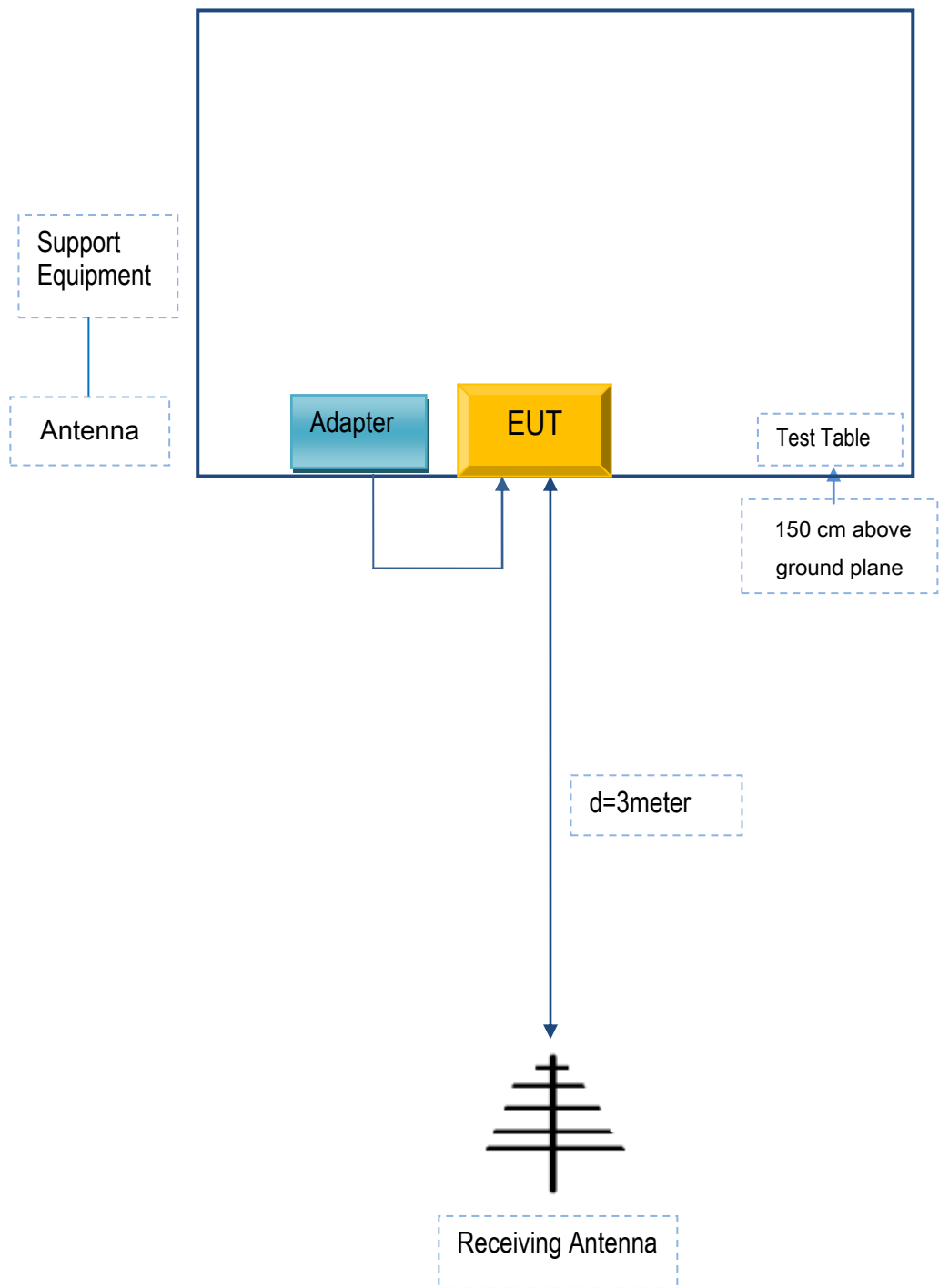

Annex C. ii. SUPPORTING EQUIPMENT DESCRIPTION

The following is a description of supporting equipment and details of cables used with the EUT.

Supporting Equipment:

| Manufacturer | Equipment Description | Model | Serial No |
|--------------------------------------|-----------------------|---------------------------|-----------|
| MOBIWIRE MOBILES (NINGBO) CO.,LTD | Adapter | öwn Fun Value Lite | R0322 |

Supporting Cable:

| Cable type | Shield Type | Ferrite Core | Length | Serial No |
|------------|--------------|--------------|--------|-----------|
| USB Cable | Un-shielding | No | 0.8m | R0322 |

| | |
|-------------|-----------------|
| Test Report | 16071337-FCC-R1 |
| Page | 79 of 81 |

Annex C.ii. EUT OPERATING CONKITIONS

N/A

| | |
|-------------|-----------------|
| Test Report | 16071337-FCC-R1 |
| Page | 80 of 81 |

Annex D. User Manual / Block Diagram / Schematics / Partlist

Please see the attachment

| | |
|-------------|-----------------|
| Test Report | 16071337-FCC-R1 |
| Page | 81 of 81 |

Annex E. DECLARATION OF SIMILARITY

N/A