

# RF TEST REPORT



Report No.: 16071065-FCC-R1

Supersede Report No.: N/A

Applicant	MOBIWIRE MOBILES (NINGBO) CO.,LTD.	
Product Name	Mobile phone	
Model No.	A500	
Serial No.	N/A	
Test Standard	FCC Part 22(H):2015 ;FCC Part 24(E):2015; FCC Part 27:2015; ANSI/TIA-603-D: 2010	
Test Date	August 30 to September 20, 2016	
Issue Date	September 21, 2016	
Test Result	<input checked="" type="checkbox"/> Pass <input type="checkbox"/> Fail	
Equipment complied with the specification	<input checked="" type="checkbox"/>	
Equipment did not comply with the specification	<input type="checkbox"/>	
		
Loren Luo Test Engineer	David Huang Checked By	
This test report may be reproduced in full only Test result presented in this test report is applicable to the tested sample only		

Issued by:

**SIEMIC (SHENZHEN-CHINA) LABORATORIES**

Zone A, Floor 1, Building 2 Wan Ye Long Technology Park

South Side of Zhoushi Road, Bao' an District, Shenzhen, Guangdong China 518108

Phone: +86 0755 2601 4629801 Email: [China@siemic.com.cn](mailto:China@siemic.com.cn)

## Laboratories Introduction

SIEMIC, headquartered in the heart of Silicon Valley, with superior facilities in US and Asia, is one of the leading independent testing and certification facilities providing customers with one-stop shop services for Compliance Testing and Global Certifications.



In addition to testing and certification, SIEMIC provides initial design reviews and compliance management throughout a project. Our extensive experience with China, Asia Pacific, North America, European, and International compliance requirements, assures the fastest, most cost effective way to attain regulatory compliance for the global markets.

### Accreditations for Conformity Assessment

Country/Region	Scope
USA	EMC, RF/Wireless, SAR, Telecom
Canada	EMC, RF/Wireless, SAR, Telecom
Taiwan	EMC, RF, Telecom, SAR, Safety
Hong Kong	RF/Wireless, SAR, Telecom
Australia	EMC, RF, Telecom, SAR, Safety
Korea	EMI, EMS, RF, SAR, Telecom, Safety
Japan	EMI, RF/Wireless, SAR, Telecom
Singapore	EMC, RF, SAR, Telecom
Europe	EMC, RF, SAR, Telecom, Safety

Test Report	16071065-FCC-R1
Page	3 of 104

---

This page has been left blank intentionally.

# CONTENTS

SUPERSEDE REPORT NO.: N/A .....	1
ISSUED BY: .....	1
LABORATORIES INTRODUCTION .....	2
ACCREDITATIONS FOR CONFORMITY ASSESSMENT .....	2
THIS PAGE HAS BEEN LEFT BLANK INTENTIONALLY .....	3
CONTENTS.....	4
1. REPORT REVISION HISTORY .....	6
2. CUSTOMER INFORMATION .....	6
3. TEST SITE INFORMATION.....	6
4. EQUIPMENT UNDER TEST (EUT) INFORMATION .....	7
5. TEST SUMMARY .....	10
MEASUREMENT UNCERTAINTY .....	10
6. MEASUREMENTS, EXAMINATION AND DERIVED RESULTS .....	11
6.1 RF EXPOSURE (SAR).....	11
6.2 RF OUTPUT POWER .....	12
6.3 PEAK-AVERAGE RATIO.....	24
6.4 OCCUPIED BANDWIDTH.....	29
TEST PLOTS .....	35
6.5 SPURIOUS EMISSIONS AT ANTENNA TERMINALS.....	44
6.6 SPURIOUS RADIATED EMISSIONS.....	60
6.7 BAND EDGE.....	67
TEST PLOTS .....	73

Test Report	16071065-FCC-R1
Page	5 of 104

---

<b>6.8 FREQUENCY STABILITY .....</b>	<b>82</b>
<b>ANNEX A. TEST INSTRUMENT.....</b>	<b>93</b>
<b>ANNEX B. EUT AND TEST SETUP PHOTOGRAPHS.....</b>	<b>95</b>
<b>ANNEX C. TEST SETUP AND SUPPORTING EQUIPMENT.....</b>	<b>100</b>
<b>ANNEX C.II. EUT OPERATING CONKITIONS.....</b>	<b>102</b>
<b>ANNEX D. USER MANUAL / BLOCK DIAGRAM / SCHEMATICS / PARTLIST .....</b>	<b>103</b>
<b>ANNEX E. DECLARATION OF SIMILARITY.....</b>	<b>104</b>

## 1. Report Revision History

Report No.	Report Version	Description	Issue Date
16071065-FCC-R1	NONE	Original	September 21, 2016

## 2. Customer information

Applicant Name	MOBIWIRE MOBILES (NINGBO) CO.,LTD.
Applicant Add	No.999,Dacheng East Road,Fenghua City,Zhejiang
Manufacturer	MOBIWIRE MOBILES (NINGBO) CO.,LTD
Manufacturer Add	No.999,Dacheng East Road,Fenghua City,Zhejiang

## 3. Test site information

Lab performing tests	SIEMIC (Shenzhen-China) LABORATORIES
Lab Address	Zone A, Floor 1, Building 2 Wan Ye Long Technology Park South Side of Zhoushi Road, Bao' an District, Shenzhen, Guangdong China 518108
FCC Test Site No.	718246
IC Test Site No.	4842E-1
Test Software	Radiated Emission Program-To Shenzhen v2.0

## 4. Equipment under Test (EUT) Information

Description of EUT:	Mobile phone
Main Model:	A500
Serial Model:	N/A
Date EUT received:	August 29, 2016
Test Date(s):	August 30 to September 20, 2016
Equipment Category :	PCE
Antenna Gain:	GSM850: -1dBi PCS1900: -2dBi UMTS-FDD Band V: -1dBi UMTS-FDD Band IV: -1dBi UMTS-FDD Band II: -2dBi Bluetooth/BLE/WIFI: -2dBi GPS: -2dBi
Type of Modulation:	GSM / GPRS: GMSK EGPRS: GMSK UMTS-FDD: QPSK 802.11b/g/n: DSSS, OFDM Bluetooth: GFSK, $\pi$ /4DQPSK, 8DPSK BLE: GFSK GPS: BPSK
Input Power:	Adapter: Model: A8+-500550 Input: AC 100-240V~50/60Hz;0.2A Max Output: DC 5.0V,550mA Battery: Model: H5012 Nominal Voltage: 3.8V;2150mAh;8.17Wh Charging Voltage: DC 4.35V

GSM Voice:GSM850: 32.17dBm

PCS1900: 29.81dBm

GPRS:GSM850: 32.12dBm

PCS1900: 29.78dBm

MCS1:GSM850: 32.08dBm

PCS1900: 29.78dBm

RMC:UMTS-FDD Band V: 21.65dBm

UMTS-FDD Band IV: 21.63 dBm

Maximum Conducted

UMTS-FDD Band II: 21.51 dBm

AV Power to Antenna:

HSUPA:UMTS-FDD Band V: 20.99 dBm

UMTS-FDD Band IV: 20.93 dBm

UMTS-FDD Band II: 20.95dBm

HSDPA:UMTS-FDD Band V: 20.98 dBm

UMTS-FDD Band IV: 20.99 dBm

UMTS-FDD Band II: 20.93dBm

GSM Voice:GSM850: 29.21 dBm / ERP

PCS1900: 27.85 dBm / EIRP

GPRS:GSM850: 29.21 dBm / ERP

PCS1900: 27.7 dBm / EIRP

EGPRS:GSM850: 28.86 dBm / ERP

PCS1900: 27.85 dBm / EIRP

ERP/EIRP:

RMC:UMTS-FDD Band V: 18.62 dBm / ERP

UMTS-FDD Band IV: 20.6 dBm / ERP

UMTS-FDD Band II: 19.77 dBm / EIRP

HSUPA:UMTS-FDD Band V: 17.99 dBm / ERP

UMTS-FDD Band IV: 19.79 dBm / ERP

UMTS-FDD Band II: 18.86 dBm / EIRP

HSDPA:UMTS-FDD Band V: 18.22 dBm / ERP

UMTS-FDD Band IV: 19.67 dBm / ERP

UMTS-FDD Band II: 18.83 dBm / EIRP

Port:

Earphone Port, USB Port

Number of Channels:

GSM 850: 124CH  
 PCS1900: 299CH  
 UMTS-FDD Band V : 102CH  
 UMTS-FDD Band IV: 202CH  
 UMTS-FDD Band II : 277CH  
 WIFI :802.11b/g/n(20M): 11CH  
 WIFI :802.11n(40M): 7CH  
 Bluetooth: 79CH  
 BLE: 40CH  
 GPS:1CH

RF Operating Frequency (ies):

GSM850 TX: 824.2 ~ 848.8 MHz; RX: 869.2 ~ 893.8 MHz  
 PCS1900 TX: 1850.2 ~ 1909.8 MHz; RX: 1930.2 ~ 1989.8 MHz  
 UMTS-FDD Band V TX: 826.4 ~ 846.6 MHz; RX: 871.4 ~ 891.6 MHz  
 UMTS-FDD Band IV TX:1712.4 ~ 1752.6 MHz;  
 RX : 2112.4 ~ 2152.6 MHz  
 UMTS-FDD Band II TX:1852.4 ~ 1907.6 MHz;  
 RX: 1932.4 ~ 1987.6 MHz  
 WIFI: 802.11b/g/n(20M): 2412-2462 MHz  
 WIFI: 802.11n(40M): 2422-2452 MHz  
 Bluetooth& BLE: 2402-2480 MHz  
 GPS: 1575.42 MHz

Trade Name : N/A

GPRS/EGPRS Multi-slot class 8/10/12

FCC ID: 2ADA4A500

Antenna Type: PIFA antenna

## 5. Test Summary

The product was tested in accordance with the following specifications.

All testing has been performed according to below product classification:

FCC Rules	Description of Test	Result
§ 1.1307; § 2.1093	RF Exposure (SAR)	Compliance
§2.1046; § 22.913(a); § 24.232(c); § 27.50(c.10) ; § 27.50(d.4)	RF Output Power	Compliance
§ 24.232 (d) ; § 27.50(d)	Peak-Average Ratio	Compliance
§ 2.1049; § 22.905; § 22.917; § 24.238; § 27.53(a.5)	99% & -26 dB Occupied Bandwidth	Compliance
§ 2.1051; § 22.917(a); § 24.238(a); § 27.53(h)	Spurious Emissions at Antenna Terminal	Compliance
§ 2.1053; § 22.917(a); § 24.238(a); § 27.53(h)	Field Strength of Spurious Radiation	Compliance
§ 22.917(a); § 24.238(a); § 27.53(h)	Out of band emission, Band Edge	Compliance
§ 2.1055; § 22.355; § 24.235; § 27.5(h); § 27.54	Frequency stability vs. temperature Frequency stability vs. voltage	Compliance

Note: Testing was performed by configuring EUT to maximum output power status, the declared output power class for different

### Measurement Uncertainty

Emissions		
Test Item	Description	Uncertainty
Band Edge and Radiated Spurious Emissions	Confidence level of approximately 95% (in the case where distributions are normal), with a coverage factor of 2 (for EUTs < 0.5m X 0.5m X 0.5m)	+5.6dB/-4.5dB
-	-	-

## 6. MEASUREMENTS, EXAMINATION AND DERIVED RESULTS

### 6.1 RF Exposure (SAR)

Test Result: Pass

The EUT is a portable device, thus requires SAR evaluation;

Please refer to RF Exposure Evaluation Report: 16071065-FCC-H.

## 6.2 RF Output Power

Temperature	24°C
Relative Humidity	52%
Atmospheric Pressure	1019mbar
Test date :	September 19, 2016
Tested By :	Loren Luo

### Requirement(s):

Spec	Item	Requirement	Applicable
§22.913 (a)	a)	ERP:38.45dBm	<input checked="" type="checkbox"/>
§24.232 (c)	b)	EIRP:33dBm	<input checked="" type="checkbox"/>
§27.50 (c)	c)	EIRP: 30dBm	<input checked="" type="checkbox"/>

### Test Setup

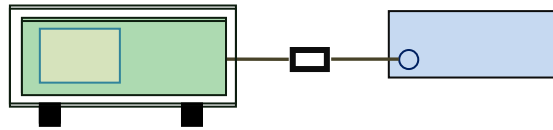

### Test Procedure

#### For Conducted Power:

- The transmitter output port was connected to base station.
- Set EUT at maximum power through base station.
- Select lowest, middle, and highest channels for each band and different test mode.

#### For ERP/EIRP:

According with KDB 971168 v02r02

- The transmitter was placed on a wooden turntable, and it was transmitting into a non-radiating load which was also placed on the turntable.
- The measurement antenna was placed at a distance of 3 meters from the EUT. During the tests, the antenna height and polarization as well as EUT azimuth were varied in order to identify the maximum level of emissions from the EUT. The test was performed by placing the EUT on 3-orthogonal axis.
- The frequency range up to tenth harmonic of the fundamental

	<p>frequency was investigated.</p> <ul style="list-style-type: none"> <li>- Remove the EUT and replace it with substitution antenna. A signal generator was connected to the substitution antenna by a non-radiating cable. The absolute levels of the spurious emissions were measured by the substitution.</li> <li>- Spurious emissions in dB = 10 log (TX power in Watts/0.001) – the absolute level</li> <li>- Spurious attenuation limit in dB = 43 + 10 Log10 (power out in Watts).</li> </ul>
Remark	
Result	<input checked="" type="checkbox"/> Pass <input type="checkbox"/> Fail

Test Data     Yes                       N/A

Test Plot     Yes (See below)             N/A

## Conducted Power

### GSM Mode:

Burst Average Power (dBm);								
Band	GSM850				PCS1900			
Channel	128	190	251	Tune up Power tolerant	512	661	810	Tune up Power tolerant
Frequency (MHz)	824.2	836.6	848.8	/	1850.2	1880	1909.8	/
GSM Voice (1 uplink),GMSK	32.12	<b>32.17</b>	32.12	32±1	<b>29.81</b>	29.71	29.43	29±1
GPRS Multi-Slot Class 8 (1 uplink),GMSK	32.07	<b>32.12</b>	32.09	32±1	<b>29.78</b>	29.32	29.25	29±1
GPRS Multi-Slot Class 10 (2 uplink) GMSK	31.52	31.56	31.52	31±1	29.24	28.68	27.88	28.5±1
GPRS Multi-Slot Class 12 (4 uplink) GMSK	28.86	28.74	28.61	28±1	26.29	25.53	25.65	25.5±1
EGPRS Multi-Slot Class 8 (1 uplink) GMSK MCS1	32.06	<b>32.08</b>	32.03	32±1	<b>29.78</b>	29.31	29.18	29±1
EGPRS Multi-Slot Class 10 (2 uplink) GMSK MCS1	31.47	31.51	31.51	31±1	29.2	28.65	27.4	28.3±1
EGPRS Multi-Slot Class 12 (4 uplink) GMSK MCS1	28.82	28.73	28.59	28±1	26.09	25.35	24.66	25.5±1

Remark :

GPRS, CS1 coding scheme.

EGPRS, MCS1 coding scheme.

Multi-Slot Class 8 , Support Max 4 downlink, 1 uplink , 5 working link

Multi-Slot Class 10 , Support Max 4 downlink, 2 uplink , 5 working link

Multi-Slot Class 12 , Support Max 4 downlink, 4 uplink , 5 working link

## UMTS Mode:

### UMTS-FDD Band V

Band/ Time Slot configuration	Channel	Frequency	Average power (dBm)	Tune up Power tolerant
RMC 12.2kbps	4132	826.4	21.57	21.5±1
	4175	835	<b>21.65</b>	21.5±1
	4233	846.6	21.64	21.5±1
HSDPA Subtest1	4132	826.4	20.88	21.3±1
	4175	835	20.91	21.3±1
	4233	846.6	20.95	21.3±1
HSDPA Subtest2	4132	826.4	20.97	21.3±1
	4175	835	<b>20.98</b>	21.3±1
	4233	846.6	20.89	21.3±1
HSDPA Subtest3	4132	826.4	20.83	21.3±1
	4175	835	20.86	21.3±1
	4233	846.6	20.84	21.3±1
HSDPA Subtest4	4132	826.4	20.85	21.3±1
	4175	835	20.88	21.3±1
	4233	846.6	20.86	21.3±1
HSUPA Subtest1	4132	826.4	20.82	21.3±1
	4175	835	20.89	21.3±1
	4233	846.6	20.95	21.3±1
HSUPA Subtest2	4132	826.4	20.93	21.3±1
	4175	835	20.98	21.3±1
	4233	846.6	20.97	21.3±1
HSUPA Subtest3	4132	826.4	20.93	21.3±1
	4175	835	20.95	21.3±1
	4233	846.6	20.98	21.3±1
HSUPA Subtest4	4132	826.4	20.96	21.3±1
	4175	835	<b>20.99</b>	21.3±1
	4233	846.6	20.94	21.3±1
HSUPA Subtest5	4132	826.4	20.96	21.3±1
	4175	835	20.93	21.3±1
	4233	846.6	20.91	21.3±1

## UMTS-FDD Band II

Band/ Time Slot configuration	Channel	Frequency	Average power (dBm)	Tune up Power tolerant
RMC 12.2kbps	9262	1852.4	21.38	21.5±1
	9400	1880	<b>21.51</b>	21.5±1
	9538	1907.6	21.25	21.5±1
HSDPA Subtest1	9262	1852.4	20.58	21.3±1
	9400	1880	20.59	21.3±1
	9538	1907.6	20.67	21.3±1
HSDPA Subtest2	9262	1852.4	20.81	21.3±1
	9400	1880	<b>20.93</b>	21.3±1
	9538	1907.6	20.86	21.3±1
HSDPA Subtest3	9262	1852.4	20.8	21.3±1
	9400	1880	20.55	21.3±1
	9538	1907.6	20.53	21.3±1
HSDPA Subtest4	9262	1852.4	20.54	21.3±1
	9400	1880	20.59	21.3±1
	9538	1907.6	20.62	21.3±1
HSUPA Subtest1	9262	1852.4	20.68	21.3±1
	9400	1880	20.64	21.3±1
	9538	1907.6	20.63	21.3±1
HSUPA Subtest2	9262	1852.4	20.67	21.3±1
	9400	1880	20.62	21.3±1
	9538	1907.6	20.73	21.3±1
HSUPA Subtest3	9262	1852.4	20.74	21.3±1
	9400	1880	20.79	21.3±1
	9538	1907.6	20.78	21.3±1
HSUPA Subtest4	9262	1852.4	20.83	21.3±1
	9400	1880	20.46	21.3±1
	9538	1907.6	20.35	21.3±1
HSUPA Subtest5	9262	1852.4	20.77	21.3±1
	9400	1880	<b>20.95</b>	21.3±1
	9538	1907.6	20.73	21.3±1

## UMTS-FDD Band IV

Band/ Time Slot configuration	Channel	Frequency	Average power (dBm)	Tune up Power tolerant
RMC 12.2kbps	4132	826.4	21.39	21.5±1
	4175	835	<b>21.63</b>	21.5±1
	4233	846.6	21.36	21.5±1
HSDPA Subtest1	4132	826.4	<b>20.99</b>	21.3±1
	4175	835	20.78	21.3±1
	4233	846.6	20.72	21.3±1
HSDPA Subtest2	4132	826.4	20.86	21.3±1
	4175	835	20.95	21.3±1
	4233	846.6	20.84	21.3±1
HSDPA Subtest3	4132	826.4	20.78	21.3±1
	4175	835	20.73	21.3±1
	4233	846.6	20.85	21.3±1
HSDPA Subtest4	4132	826.4	20.82	21.3±1
	4175	835	20.86	21.3±1
	4233	846.6	20.81	21.3±1
HSUPA Subtest1	4132	826.4	20.75	21.3±1
	4175	835	20.69	21.3±1
	4233	846.6	20.85	21.3±1
HSUPA Subtest2	4132	826.4	20.84	21.3±1
	4175	835	20.89	21.3±1
	4233	846.6	20.7	21.3±1
HSUPA Subtest3	4132	826.4	20.76	21.3±1
	4175	835	20.78	21.3±1
	4233	846.6	20.73	21.3±1
HSUPA Subtest4	4132	826.4	20.63	21.3±1
	4175	835	20.88	21.3±1
	4233	846.6	20.72	21.3±1
HSUPA Subtest5	4132	826.4	20.79	21.3±1
	4175	835	20.79	21.3±1
	4233	846.6	<b>20.93</b>	21.3±1

## ERP & EIRP

### GSM Voice

#### ERP for Cellular Band (Part 22H)

Frequency (MHz)	Substituted level (dBm)	Antenna Polarization	Antenna Gain correction (dBi)	Cable Loss (dB)	Absolute Level (dBm)	Limit (dBm)
824.2	22.68	V	6.8	0.53	28.95	38.45
824.2	21.34	H	6.8	0.53	27.61	38.45
836.6	22.73	V	6.8	0.53	29	38.45
836.6	21.49	H	6.8	0.53	27.76	38.45
848.8	22.84	V	6.9	0.53	<b>29.21</b>	38.45
848.8	21.17	H	6.9	0.53	27.54	38.45

#### EIRP for PCS Band (Part 24E)

Frequency (MHz)	Substituted level (dBm)	Antenna Polarization	Antenna Gain correction (dBi)	Cable Loss (dB)	Absolute Level (dBm)	Limit (dBm)
1850.2	20.82	V	7.88	0.85	<b>27.85</b>	33
1850.2	19.65	H	7.88	0.85	26.68	33
1880	20.69	V	7.88	0.85	27.72	33
1880	19.24	H	7.88	0.85	26.27	33
1909.8	20.75	V	7.86	0.85	27.76	33
1909.8	19.36	H	7.86	0.85	26.37	33

**GPRS:**

**ERP for Cellular Band (Part 22H)**

Frequency (MHz)	Substituted level (dBm)	Antenna Polarization	Antenna Gain correction (dBi)	Cable Loss (dB)	Absolute Level (dBm)	Limit (dBm)
824.2	22.58	V	6.8	0.53	28.85	38.45
824.2	21.1	H	6.8	0.53	27.37	38.45
836.6	22.61	V	6.8	0.53	28.88	38.45
836.6	21.34	H	6.8	0.53	27.61	38.45
848.8	22.84	V	6.9	0.53	<b>29.21</b>	38.45
848.8	21.28	H	6.9	0.53	27.65	38.45

**EIRP for PCS Band (Part 24E)**

Frequency (MHz)	Substituted level (dBm)	Antenna Polarization	Antenna Gain correction (dBi)	Cable Loss (dB)	Absolute Level (dBm)	Limit (dBm)
1850.2	20.21	V	7.88	0.85	27.24	33
1850.2	18.92	H	7.88	0.85	25.95	33
1880	20.65	V	7.88	0.85	27.68	33
1880	19.52	H	7.88	0.85	26.55	33
1909.8	20.69	V	7.86	0.85	<b>27.7</b>	33
1909.8	19.42	H	7.86	0.85	26.43	33

**EGPRS (MCS1):**

**ERP for Cellular Band (Part 22H)**

Frequency (MHz)	Substituted level (dBm)	Antenna Polarization	Antenna Gain correction (dBi)	Cable Loss (dB)	Absolute Level (dBm)	Limit (dBm)
824.2	22.23	V	6.8	0.53	28.5	38.45
824.2	20.86	H	6.8	0.53	27.13	38.45
836.6	22.54	V	6.8	0.53	28.81	38.45
836.6	21.23	H	6.8	0.53	27.5	38.45
848.8	22.49	V	6.9	0.53	<b>28.86</b>	38.45
848.8	21.35	H	6.9	0.53	27.72	38.45

**EIRP for PCS Band (Part 24E)**

Frequency (MHz)	Substituted level (dBm)	Antenna Polarization	Antenna Gain correction (dBi)	Cable Loss (dB)	Absolute Level (dBm)	Limit (dBm)
1850.2	20.43	V	7.88	0.85	27.46	33
1850.2	19.26	H	7.88	0.85	26.29	33
1880	20.58	V	7.88	0.85	27.61	33
1880	19.14	H	7.88	0.85	26.17	33
1909.8	20.84	V	7.86	0.85	<b>27.85</b>	33
1909.8	19.69	H	7.86	0.85	26.7	33

## RMC

### ERP for UMTS-FDD Band V (Part 22H)

Frequency (MHz)	Substituted level (dBm)	Antenna Polarization	Antenna Gain correction (dBi)	Cable Loss (dB)	Absolute Level (dBm)	Limit (dBm)
826.4	12.23	V	6.8	0.53	18.5	38.45
826.4	11.45	H	6.8	0.53	17.72	38.45
835	12.35	V	6.8	0.53	<b>18.62</b>	38.45
835	11.61	H	6.8	0.53	17.88	38.45
846.6	12.47	V	6.9	0.53	18.84	38.45
846.6	11.32	H	6.9	0.53	17.69	38.45

### EIRP for UMTS-FDD Band II (Part 24E)

Frequency (MHz)	Substituted level (dBm)	Antenna Polarization	Antenna Gain correction (dBi)	Cable Loss (dB)	Absolute Level (dBm)	Limit (dBm)
1852.4	12.54	V	7.88	0.85	19.57	33
1852.4	11.36	H	7.88	0.85	18.39	33
1880	12.49	V	7.88	0.85	19.52	33
1880	11.28	H	7.88	0.85	18.31	33
1907.6	12.76	V	7.86	0.85	<b>19.77</b>	33
1907.6	11.54	H	7.86	0.85	18.55	33

### EIRP for UMTS-FDD Band IV (Part 27E)

Frequency (MHz)	Substituted level (dBm)	Antenna Polarization	Antenna Gain correction (dBi)	Cable Loss (dB)	Absolute Level (dBm)	Limit (dBm)
1712.4	13.46	V	7.76	0.82	20.4	30
1712.4	12.09	H	7.76	0.82	19.03	30
1740	13.24	V	7.76	0.82	20.18	30
1740	11.95	H	7.76	0.82	18.89	30
1752.6	13.68	V	7.74	0.82	<b>20.6</b>	30
1752.6	12.34	H	7.74	0.82	19.26	30

## HSDPA

### ERP for UMTS-FDD Band V (Part 22H)

Frequency (MHz)	Substituted level (dBm)	Antenna Polarization	Antenna Gain correction (dBi)	Cable Loss (dB)	Absolute Level (dBm)	Limit (dBm)
826.4	11.68	V	6.8	0.53	17.95	38.45
826.4	10.59	H	6.8	0.53	16.86	38.45
835	11.95	V	6.8	0.53	<b>18.22</b>	38.45
835	10.86	H	6.8	0.53	17.13	38.45
846.6	11.52	V	6.9	0.53	17.89	38.45
846.6	10.37	H	6.9	0.53	16.74	38.45

### EIRP for UMTS-FDD Band II (Part 24E)

Frequency (MHz)	Substituted level (dBm)	Antenna Polarization	Antenna Gain correction (dBi)	Cable Loss (dB)	Absolute Level (dBm)	Limit (dBm)
1852.4	11.76	V	7.88	0.85	18.79	33
1852.4	10.58	H	7.88	0.85	17.61	33
1880	11.63	V	7.88	0.85	18.66	33
1880	10.49	H	7.88	0.85	17.52	33
1907.6	11.82	V	7.86	0.85	<b>18.83</b>	33
1907.6	10.55	H	7.86	0.85	17.56	33

### EIRP for UMTS-FDD Band IV (Part 27E)

Frequency (MHz)	Substituted level (dBm)	Antenna Polarization	Antenna Gain correction (dBi)	Cable Loss (dB)	Absolute Level (dBm)	Limit (dBm)
1712.4	12.71	V	7.76	0.82	19.65	30
1712.4	11.24	H	7.76	0.82	18.18	30
1740	12.59	V	7.76	0.82	19.53	30
1740	11.13	H	7.76	0.82	18.07	30
1752.6	12.75	V	7.74	0.82	<b>19.67</b>	30
1752.6	11.69	H	7.74	0.82	18.61	30

## HSUPA

### ERP for UMTS-FDD Band V (Part 22H)

Frequency (MHz)	Substituted level (dBm)	Antenna Polarization	Antenna Gain correction (dBi)	Cable Loss (dB)	Absolute Level (dBm)	Limit (dBm)
826.4	11.36	V	6.8	0.53	17.63	38.45
826.4	10.23	H	6.8	0.53	16.5	38.45
835	11.72	V	6.8	0.53	<b>17.99</b>	38.45
835	10.58	H	6.8	0.53	16.85	38.45
846.6	11.53	V	6.9	0.53	17.9	38.45
846.6	10.44	H	6.9	0.53	16.81	38.45

### EIRP for UMTS-FDD Band II (Part 24E)

Frequency (MHz)	Substituted level (dBm)	Antenna Polarization	Antenna Gain correction (dBi)	Cable Loss (dB)	Absolute Level (dBm)	Limit (dBm)
1852.4	11.83	V	7.88	0.85	<b>18.86</b>	33
1852.4	10.29	H	7.88	0.85	17.32	33
1880	11.62	V	7.88	0.85	18.65	33
1880	10.54	H	7.88	0.85	17.57	33
1907.6	11.57	V	7.86	0.85	18.58	33
1907.6	10.38	H	7.86	0.85	17.39	33

### EIRP for UMTS-FDD Band IV (Part 27E)

Frequency (MHz)	Substituted level (dBm)	Antenna Polarization	Antenna Gain correction (dBi)	Cable Loss (dB)	Absolute Level (dBm)	Limit (dBm)
1712.4	12.85	V	7.76	0.82	<b>19.79</b>	30
1712.4	11.54	H	7.76	0.82	18.48	30
1740	12.69	V	7.76	0.82	19.63	30
1740	11.3	H	7.76	0.82	18.24	30
1752.6	12.79	V	7.74	0.82	19.71	30
1752.6	11.48	H	7.74	0.82	18.4	30

### 6.3 Peak-Average Ratio

Temperature	25°C
Relative Humidity	53%
Atmospheric Pressure	1020mbar
Test date :	September 20, 2016
Tested By :	Loren Luo

Requirement(s):

Spec	Item	Requirement	Applicable
§24.232(d) § 27.50(d)	a)	The peak-to-average ratio (PAR) of the transmission may not exceed 13dB.	<input checked="" type="checkbox"/>

Test Setup	
------------	--

Test Procedure	<p><b>According with KDB 971168 v02r02</b></p> <p><b>5.7.2 Alternate procedure for PAPR</b></p> <p><b>5.1.2 Peak power measurements with a peak power meter</b></p> <p>The total peak output power may be measured using a broadband peak RF power meter. The power meter must have a video bandwidth that is greater than or equal to the emission bandwidth and utilize a fast-responding diode detector.</p> <p><b>5.2.3 Average power measurement with average power meter</b></p> <p>As an alternative to the use of a spectrum/signal analyzer or EMI receiver to perform a measurement of the total in-band average output power, a wideband RF average power meter with a thermocouple detector or equivalent can be used under certain conditions</p> <p>If the EUT can be configured to transmit continuously (i.e., the burst duty cycle <math>\geq 98\%</math>) and at all times the EUT is transmitting at its maximum output</p>
----------------	--

Test Report	16071065-FCC-R1
Page	25 of 104

	<p>power level, then a conventional wide-band RF power meter can be used.</p> <p>If the EUT cannot be configured to transmit continuously (i.e., the burst duty cycle &lt; 98%), then there are two options for the use of an average power meter. First, a gated average power meter can be used to perform the measurement if the gating parameters can be adjusted such that the power is measured only over active transmission bursts at maximum output power levels. A conventional average power meter can also be used if the measured burst duty cycle is constant (i.e., duty cycle variations are less than <math>\pm 2</math> percent) by performing the measurement over the on/off burst cycles and then correcting (increasing) the measured level by a factor equal to <math>10\log(1/\text{duty cycle})</math></p>
Remark	
Result	<input checked="" type="checkbox"/> Pass <input type="checkbox"/> Fail

**Test Data**     Yes                       N/A  
**Test Plot**     Yes (See below)             N/A

**GSM : GSM 1900 PK-AV POWER (PART 24E)**

Frequency (MHz)	Conducted power(dBm)		Peak-Average Ratio(PAR)
	Peak	Average	
512	1850.2	30.78	29.81
661	1880	30.86	29.71
810	1909.8	30.59	29.43

**GPRS 1900 PK-AV POWER (PART 24E)**

Frequency (MHz)	Conducted power(dBm)		Peak-Average Ratio(PAR)
	Peak	Average	
512	1850.2	31.55	29.78
661	1880	30.96	29.32
810	1909.8	30.84	29.25

**RMC : UMTS-FDD Band 2 PK-AV POWER (PART 24E)**

Frequency (MHz)	Conducted power(dBm)		Peak-Average Ratio(PAR)
	Peak	Average	
9262	1852.4	24.71	21.38
9400	1880	24.65	21.51
9538	1907.6	24.16	21.25

**UMTS-FDD Band 4 PK-AV POWER (PART 27)**

Frequency (MHz)	Conducted power(dBm)		Peak-Average Ratio(PAR)
	Peak	Average	
1313	1712.6	24.22	21.39
1413	1732.6	24.51	21.63
1513	1752.4	24.86	21.36

**HSUPA : UMTS-FDD Band 2 PK-AV POWER (PART 24E)**

Frequency (MHz)	Conducted power(dBm)		Peak-Average Ratio(PAR)
	Peak	Average	
9262	1852.4	23.54	20.68
9400	1880	23.32	20.64
9538	1907.6	23.56	20.63

**UMTS-FDD Band 4 PK-AV POWER (PART 27)**

Frequency (MHz)	Conducted power(dBm)		Peak-Average Ratio(PAR)
	Peak	Average	
1313	1712.6	23.29	20.75
1413	1732.6	23.27	20.69
1513	1752.4	23.55	20.85

**HSDPA : UMTS-FDD Band 2 PK-AV POWER (PART 24E)**

Frequency (MHz)	Conducted power(dBm)		Peak-Average Ratio(PAR)
	Peak	Average	
9262	1852.4	23.85	20.58
9400	1880	23.36	20.59
9538	1907.6	23.33	20.67

**UMTS-FDD Band 4 PK-AV POWER (PART 27)**

Frequency (MHz)	Conducted power(dBm)		Peak-Average Ratio(PAR)
	Peak	Average	
1313	1712.6	23.47	20.99
1413	1732.6	23.24	20.78
1513	1752.4	23.28	20.72

## 6.4 Occupied Bandwidth

Temperature	24°C
Relative Humidity	59%
Atmospheric Pressure	1007mbar
Test date :	September 07, 2016
Tested By :	Loren Luo

### Requirement(s):

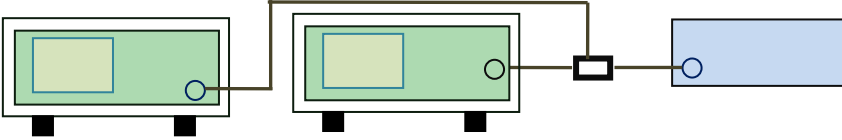
Spec	Item	Requirement	Applicable
§2.1049, §22.917, §22.905 §24.238 §27.53(a)	a)	99% Occupied Bandwidth(kHz)	<input checked="" type="checkbox"/>
	b)	26 dB Bandwidth(kHz)	<input checked="" type="checkbox"/>
Test Setup			
Test Procedure	<ul style="list-style-type: none"> <li>- The EUT was connected to Spectrum Analyzer and Base Station via power divider.</li> <li>- The 99% and 26 dB occupied bandwidth (BW) of the middle channel for the highest RF powers.</li> </ul>		
Remark			
Result	<input checked="" type="checkbox"/> Pass <input type="checkbox"/> Fail		

Test Data     Yes       N/A

Test Plot     Yes (See below)       N/A

**GSM Voice:**

**Cellular Band (Part 22H) result**

Channel	Frequency (MHz)	99% Occupied Bandwidth (kHz)	26 dB Bandwidth (kHz)
128	824.2	245.6492	321.462
190	836.6	248.6187	324.850
251	848.8	244.9969	322.420

**PCS Band (Part 24E) result**

Channel	Frequency (MHz)	99% Occupied Bandwidth (kHz)	26 dB Bandwidth (kHz)
512	1850.2	244.4882	316.461
661	1880.0	251.4370	323.371
810	1909.8	250.5203	317.443

**GPRS:**

**Cellular Band (Part 22H) result**

Channel	Frequency (MHz)	99% Occupied Bandwidth (kHz)	26 dB Bandwidth (kHz)
128	824.2	246.3335	320.913
190	836.6	248.4918	324.799
251	848.8	245.7505	323.584

**PCS Band (Part 24E) result**

Channel	Frequency (MHz)	99% Occupied Bandwidth (kHz)	26 dB Bandwidth (kHz)
512	1850.2	244.3961	323.838
661	1880.0	247.6356	313.014
810	1909.8	245.9220	321.473

**EGPRS (MCS 1):**

**Cellular Band (Part 22H) result**

Channel	Frequency (MHz)	99% Occupied Bandwidth (kHz)	26 dB Bandwidth (kHz)
128	824.2	248.6196	321.029
190	836.6	248.3588	323.238
251	848.8	250.8182	323.173

**PCS Band (Part 24E) result**

Channel	Frequency (MHz)	99% Occupied Bandwidth (kHz)	26 dB Bandwidth (kHz)
512	1850.2	245.3000	319.794
661	1880.0	244.8998	318.851
810	1909.8	247.4913	324.034

**RMC:**

**UMTS-FDD Band V (Part 22H)**

Channel	Frequency (MHz)	99% Occupied Bandwidth (MHz)	26 dB Bandwidth (MHz)
4132	826.4	4.1359	4.714
4175	835.0	4.1626	4.721
4233	846.6	4.1442	4.696

**UMTS-FDD Band IV (Part 27E)**

Channel	Frequency (MHz)	99% Occupied Bandwidth (MHz)	26 dB Bandwidth (MHz)
1313	1712.6	4.1495	4.712
1413	1732.6	4.1712	4.719
1512	1752.4	4.1508	4.713

**UMTS-FDD Band II (Part 24E)**

Channel	Frequency (MHz)	99% Occupied Bandwidth (MHz)	26 dB Bandwidth (MHz)
9262	1852.4	4.1616	4.737
9400	1880.0	4.1503	4.709
9538	1907.6	4.1539	4.712

**HSUPA:**

**UMTS-FDD Band V (Part 22H)**

Channel	Frequency (MHz)	99% Occupied Bandwidth (MHz)	26 dB Bandwidth (MHz)
4132	826.4	4.1396	4.738
4175	835.0	4.1686	4.726
4233	846.6	4.1635	4.706

**UMTS-FDD Band IV (Part 27E)**

Channel	Frequency (MHz)	99% Occupied Bandwidth (MHz)	26 dB Bandwidth (MHz)
1313	1712.6	4.1582	4.718
1413	1732.6	4.1630	4.745
1512	1752.4	4.1611	4.724

**UMTS-FDD Band II (Part 24E)**

Channel	Frequency (MHz)	99% Occupied Bandwidth (MHz)	26 dB Bandwidth (MHz)
9262	1852.4	4.1582	4.710
9400	1880.0	4.1490	4.717
9538	1907.6	4.1501	4.726

**HSDPA:**

**UMTS-FDD Band V (Part 22H)**

Channel	Frequency (MHz)	99% Occupied Bandwidth (MHz)	26 dB Bandwidth (MHz)
4132	826.4	4.1574	4.708
4175	835.0	4.1537	4.704
4233	846.6	4.1461	4.699

**UMTS-FDD Band IV (Part 27E)**

Channel	Frequency (MHz)	99% Occupied Bandwidth (MHz)	26 dB Bandwidth (MHz)
1313	1712.6	4.1654	4.727
1413	1732.6	4.1727	4.705
1512	1752.4	4.1501	4.714

**UMTS-FDD Band II (Part 24E)**

Channel	Frequency (MHz)	99% Occupied Bandwidth (MHz)	26 dB Bandwidth (MHz)
9262	1852.4	4.1605	4.723
9400	1880.0	4.2163	4.872
9538	1907.6	4.1585	4.732

**Test Plots**

**GSM Voice:**

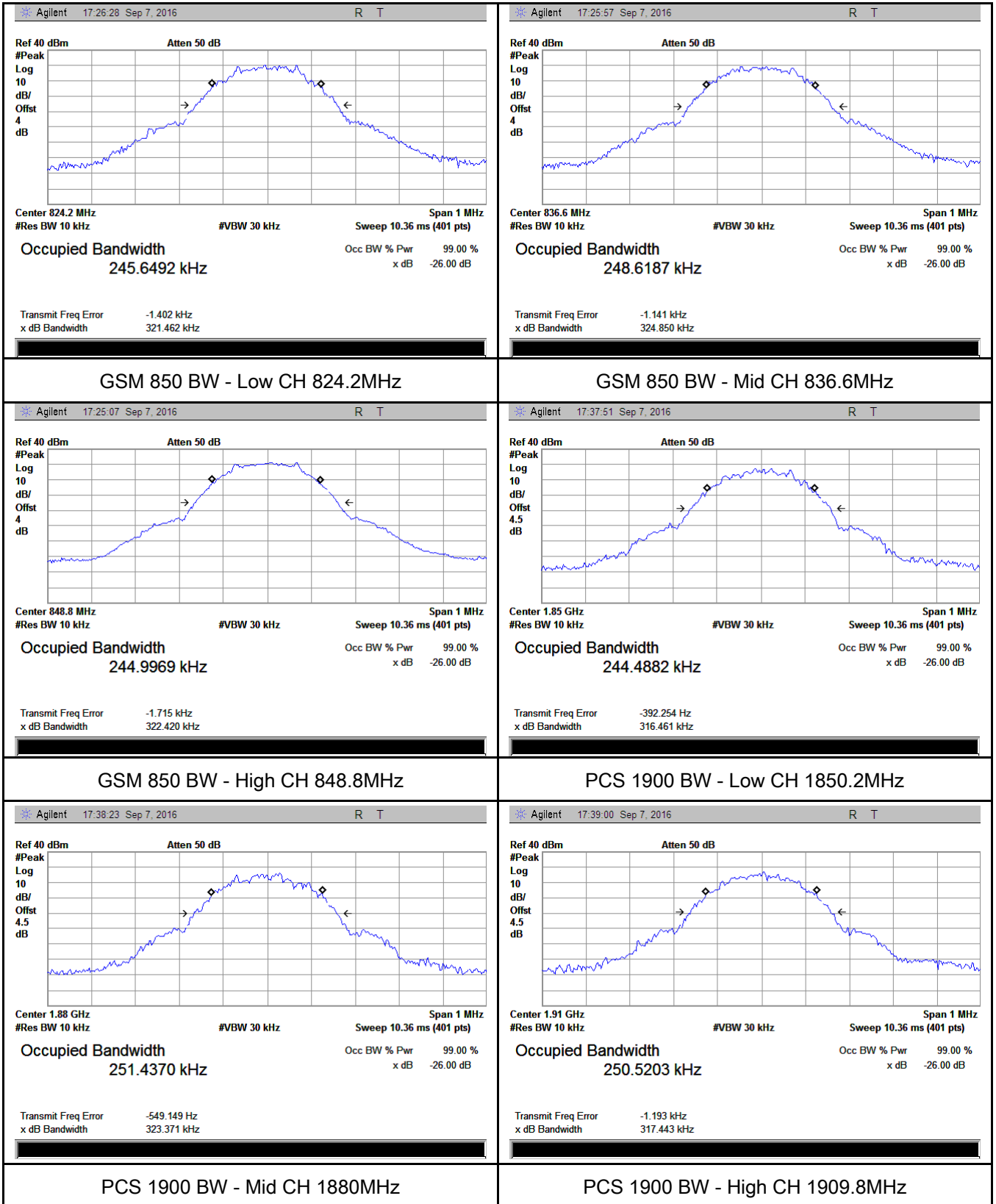

**GPRS:**

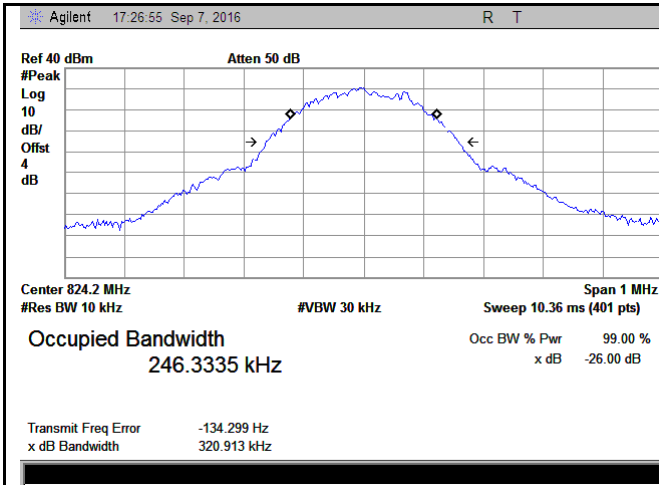

**GSM 850 BW - Low CH 824.2MHz**

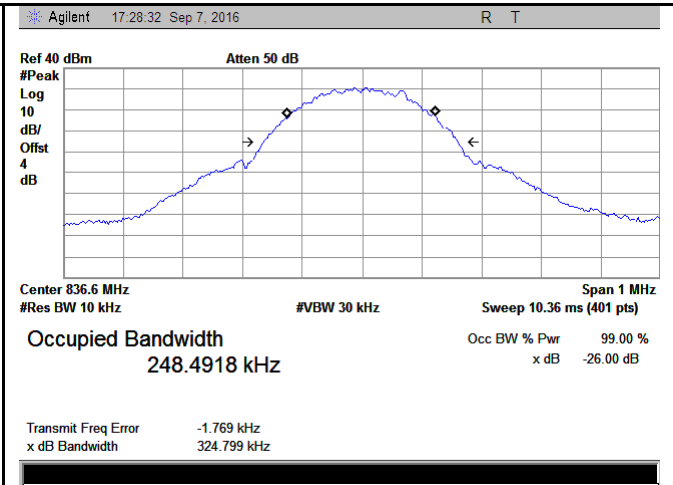

**GSM 850 BW - Mid CH 836.6MHz**

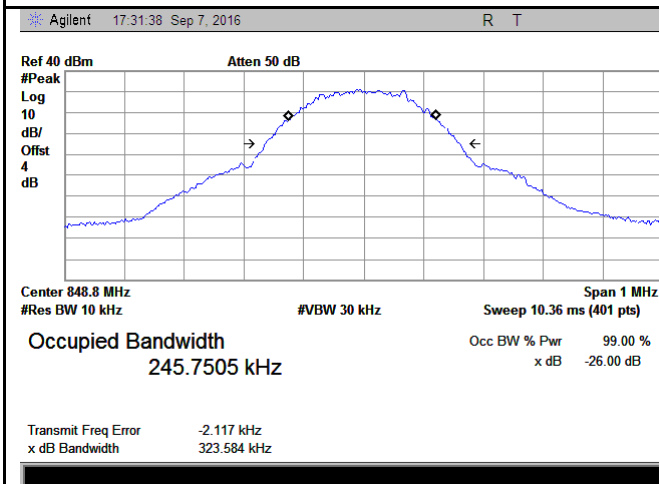

**GSM 850 BW - High CH 848.8MHz**

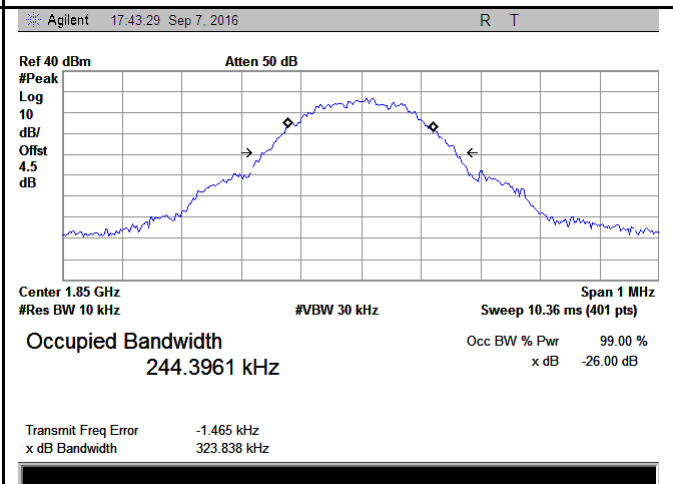

**PCS 1900 BW - Low CH 1850.2MHz**

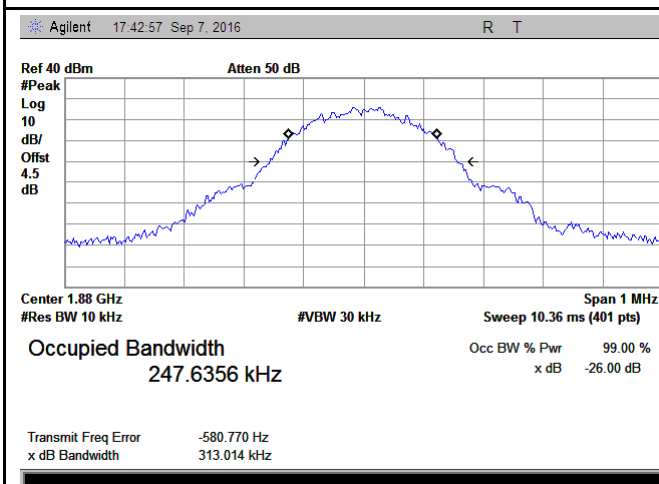

**PCS 1900 BW - Mid CH 1880MHz**

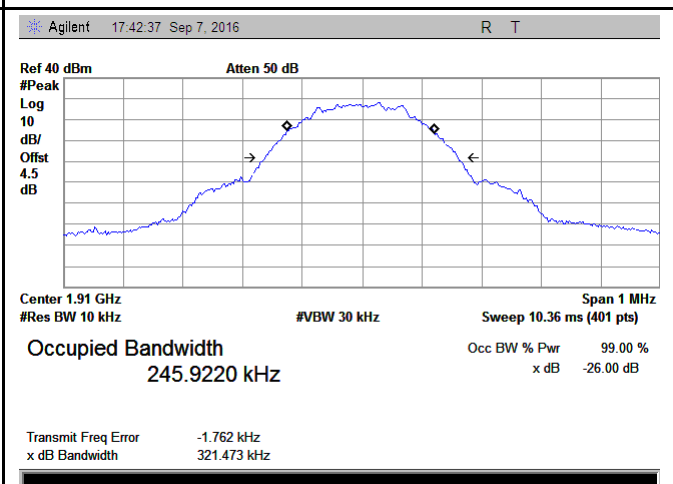

**PCS 1900 BW - High CH 1909.8MHz**

**EGPRS:**

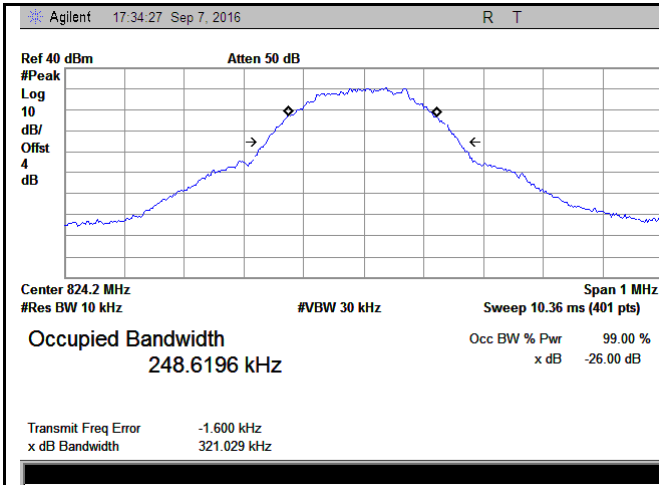

**GSM 850 BW - Low CH 824.2MHz**

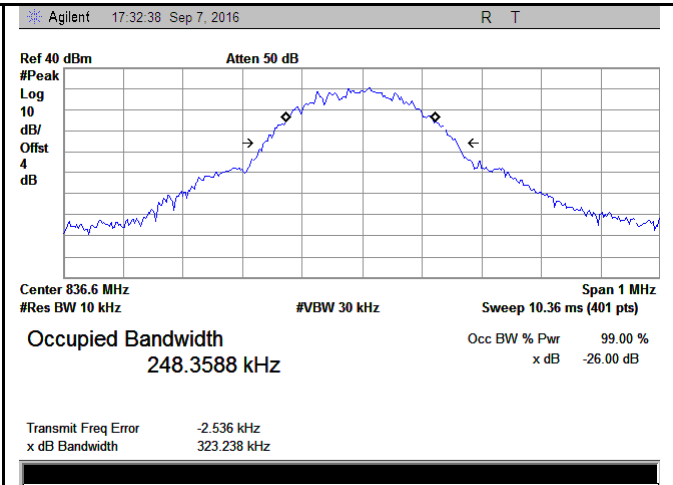

**GSM 850 BW - Mid CH 836.6MHz**

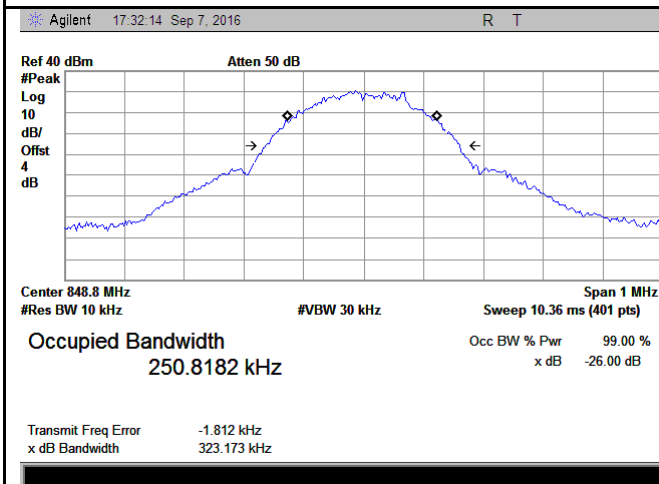

**GSM 850 BW - High CH 848.8MHz**

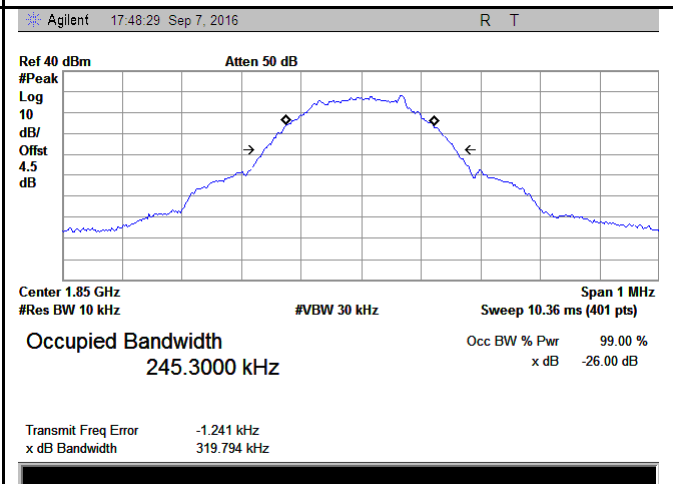

**PCS 1900 BW - Low CH 1850.2MHz**

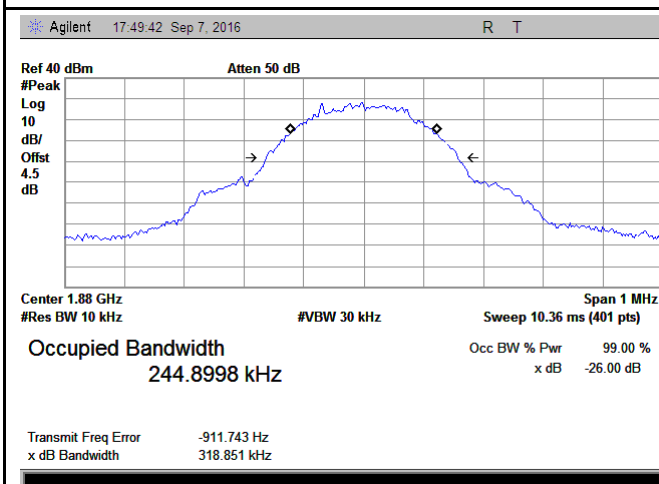

**PCS 1900 BW - Mid CH 1880MHz**

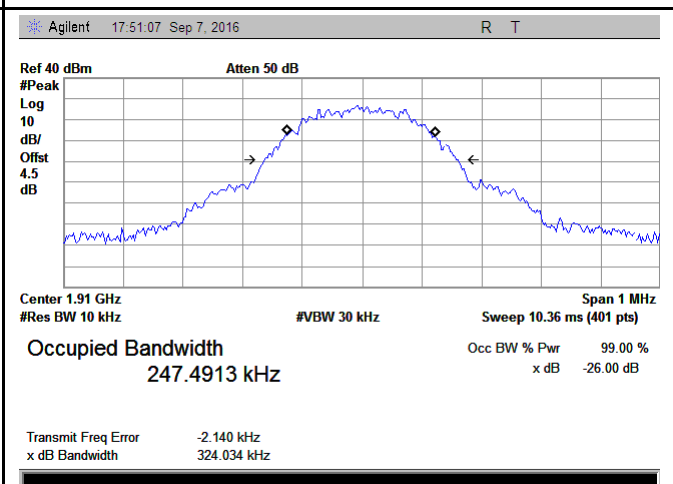

**PCS 1900 BW - High CH 1909.8MHz**

**RMC:**

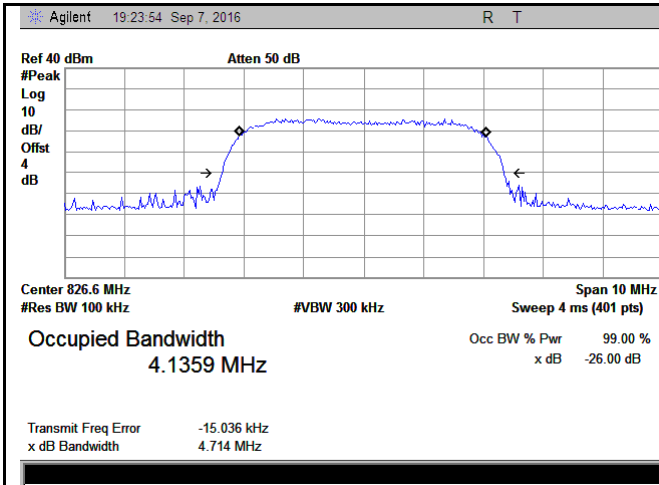

Band V BW - Low CH 826.6 MHz

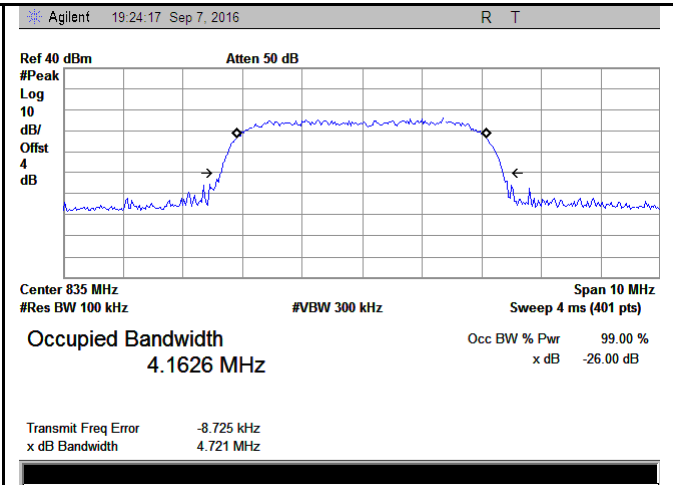

Band V BW - Mid CH 835.0 MHz

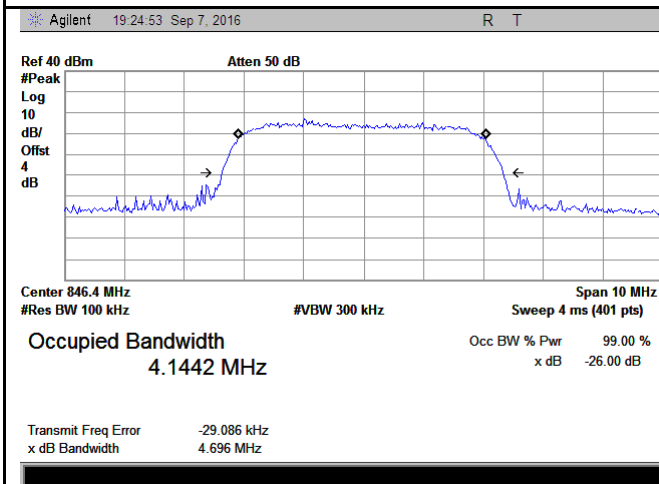

Band V BW - High CH 846.4 MHz

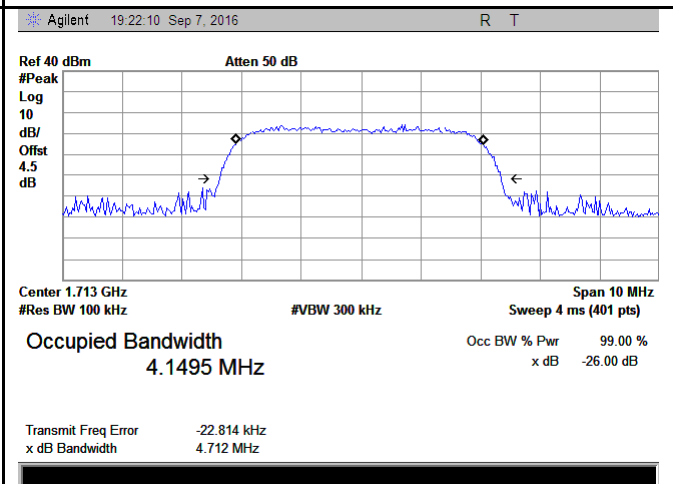

Band IV BW - Low CH 1712.6 MHz

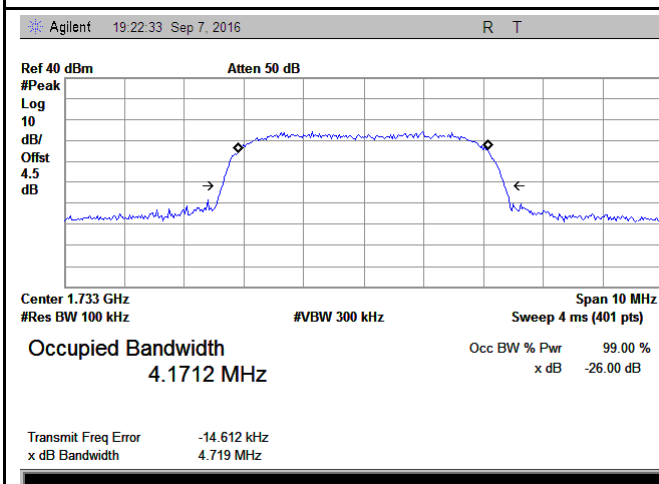

Band IV BW - Mid CH 1732.6 MHz

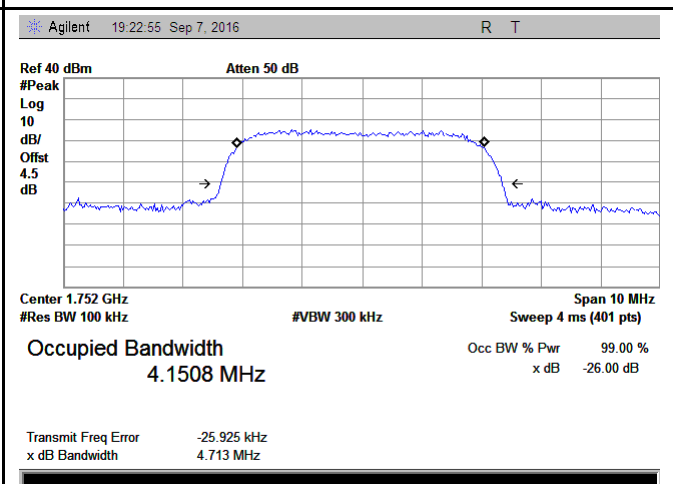

Band IV BW - High CH 1752.4 MHz

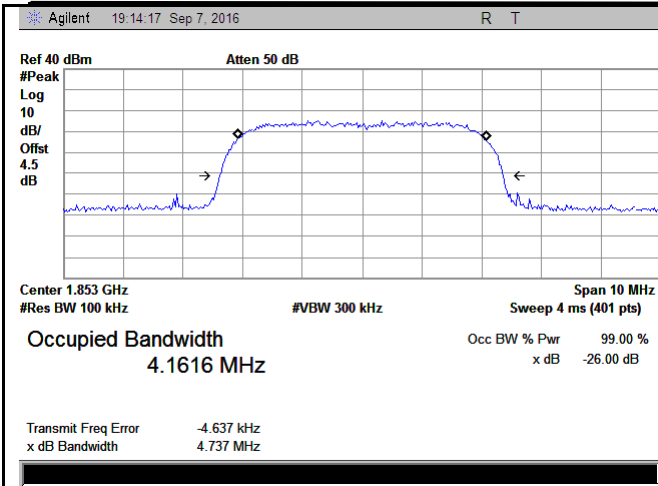

Band II BW - Low CH 1852.4MHz

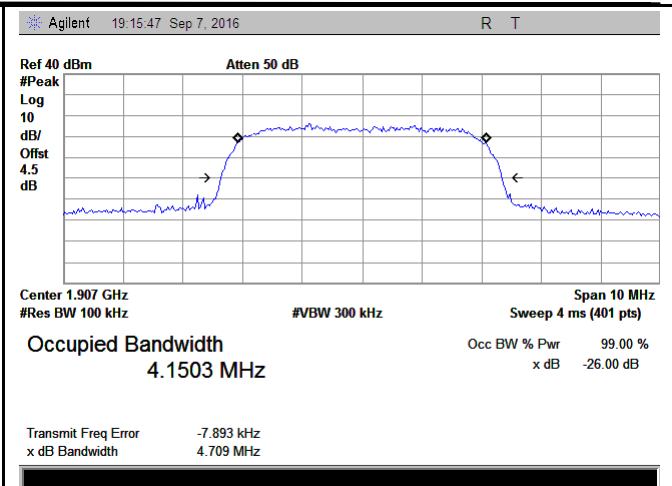

Band II BW - Mid CH 1880MHz

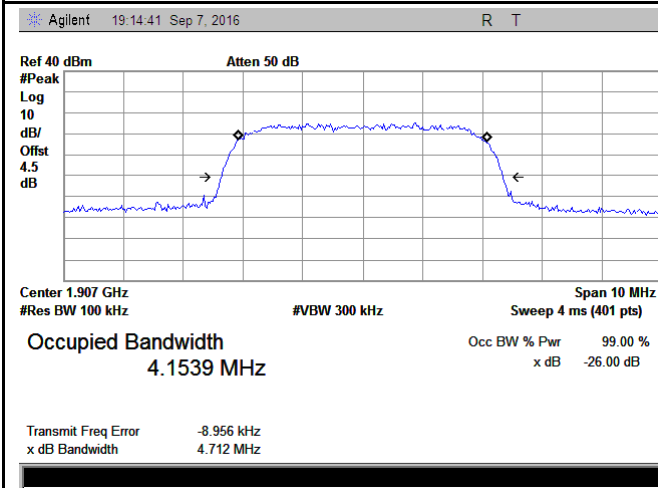

Band II BW - High CH 1907.6MHz

**HSUPA:**

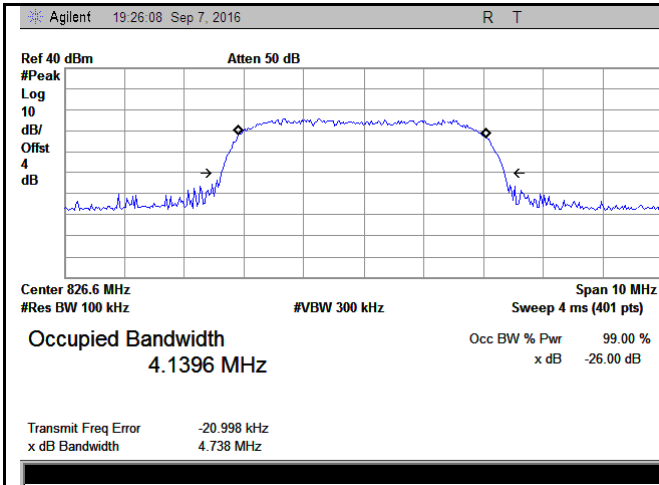

Band V BW - Low CH 826.6 MHz

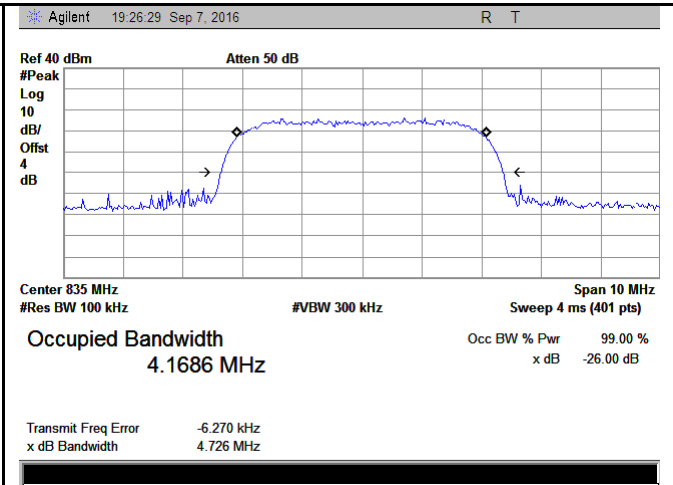

Band V BW - Mid CH 835.0 MHz

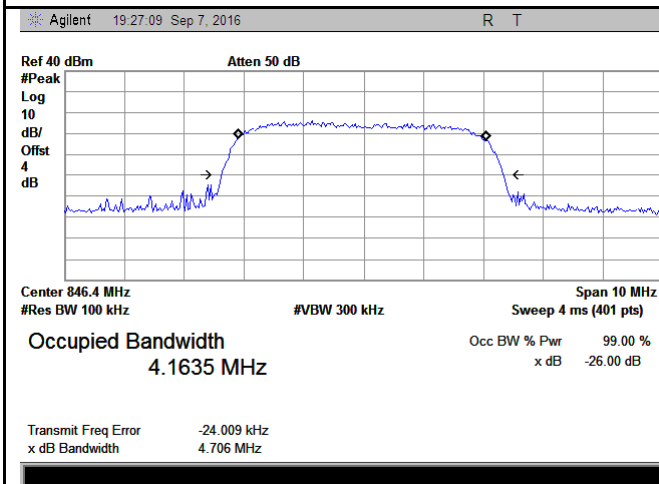

Band V BW - High CH 846.4 MHz

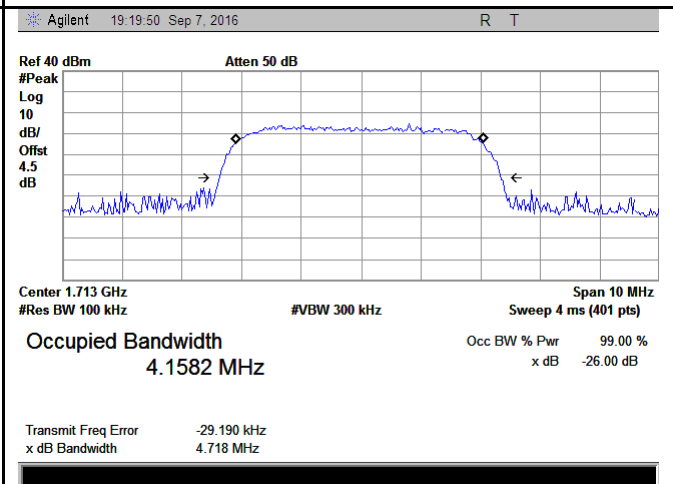

Band IV BW - Low CH 1712.6 MHz

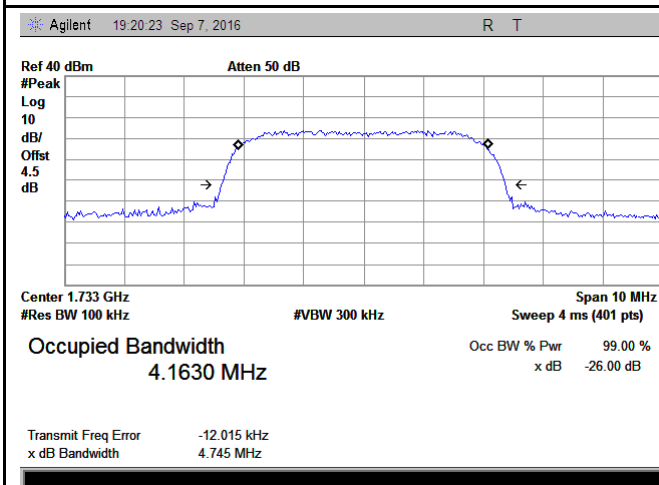

Band IV BW - Mid CH 1732.6 MHz

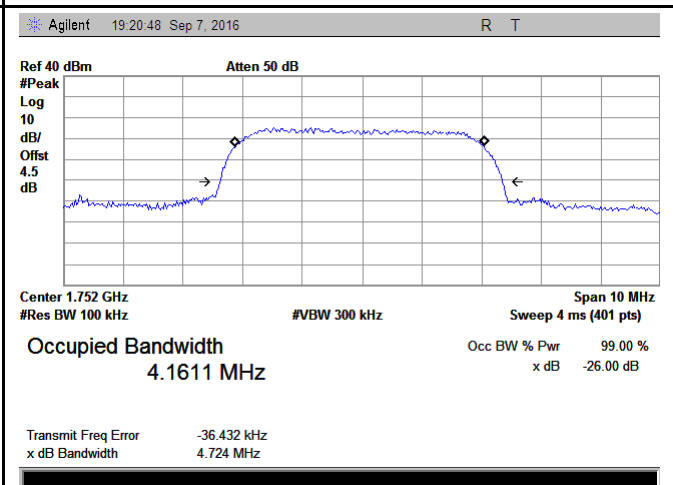

Band IV BW - High CH 1752.4 MHz

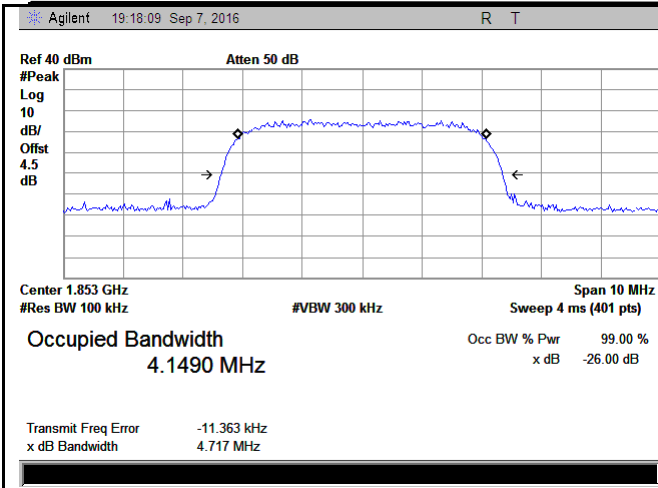

Band II BW - Low CH 1852.4MHz

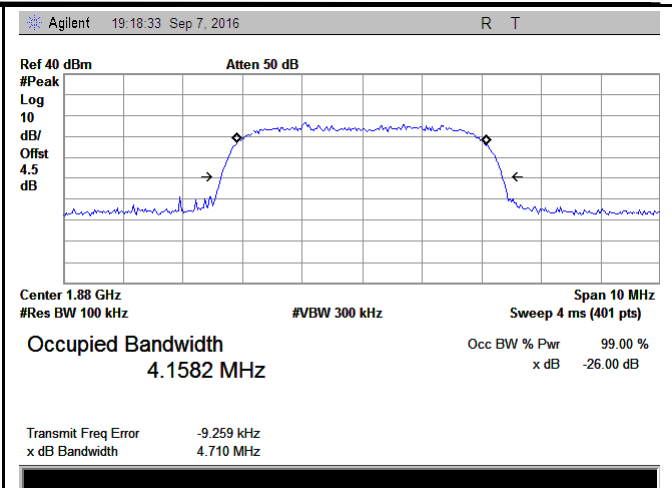

Band II BW - Mid CH 1880MHz

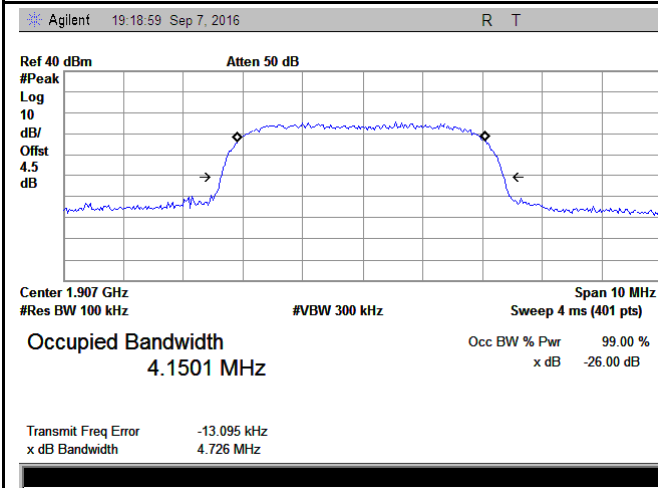

Band II BW - High CH 1907.6MHz

### HSDPA:

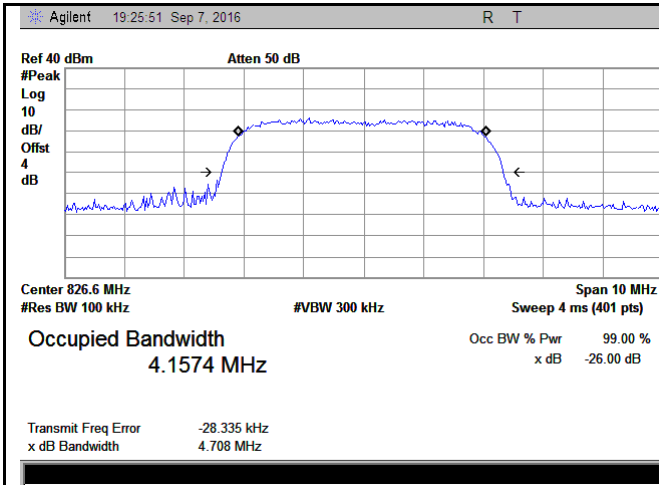

Band V BW - Low CH 826.6 MHz

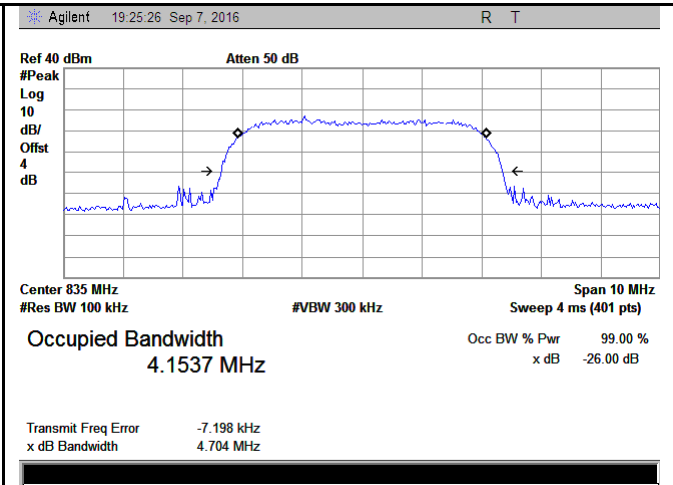

Band V BW - Mid CH 835.0 MHz

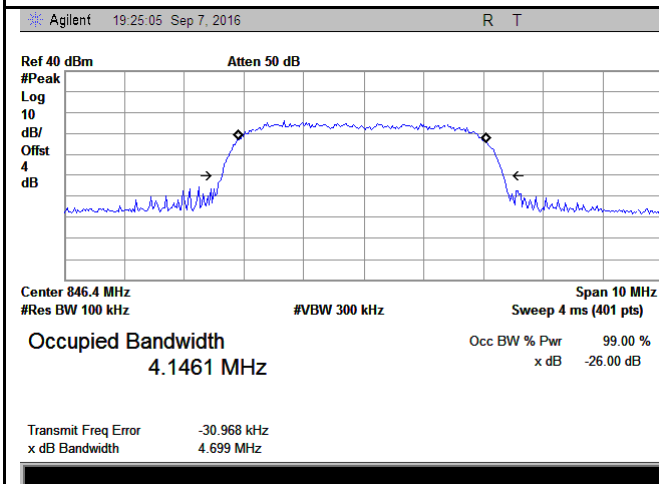

Band V BW - High CH 846.4 MHz

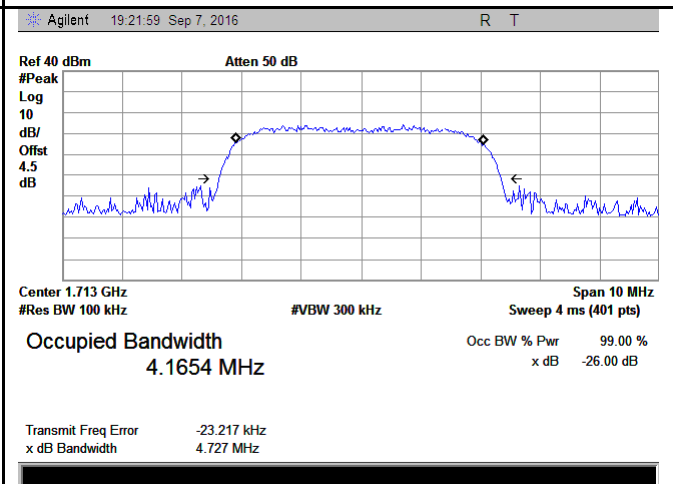

Band IV BW - Low CH 1712.6 MHz

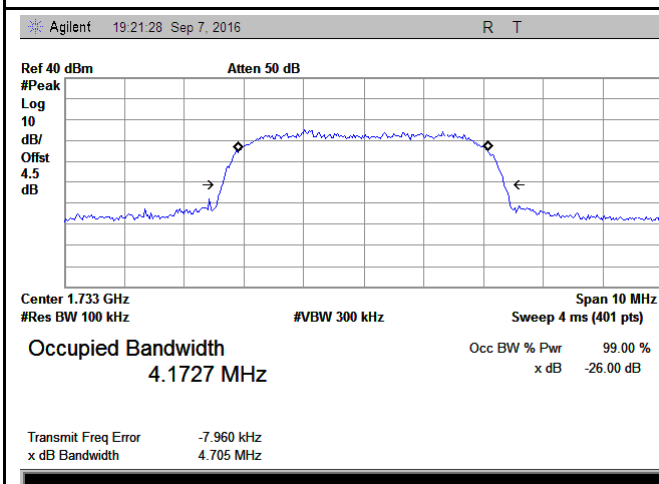

Band IV BW - Mid CH 1732.6 MHz

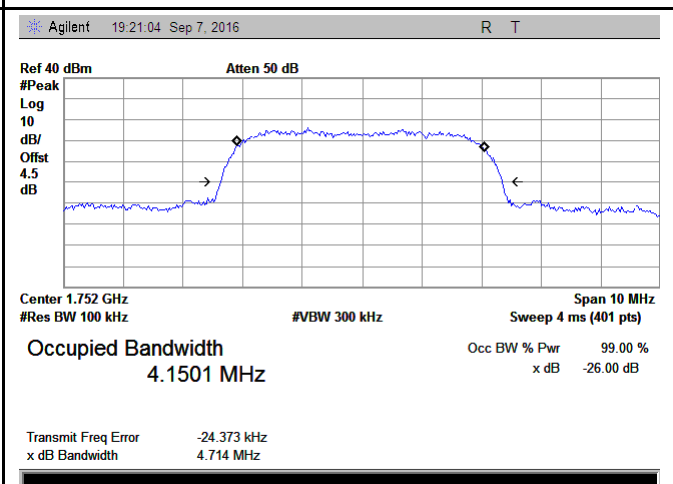

Band IV BW - High CH 1752.4 MHz

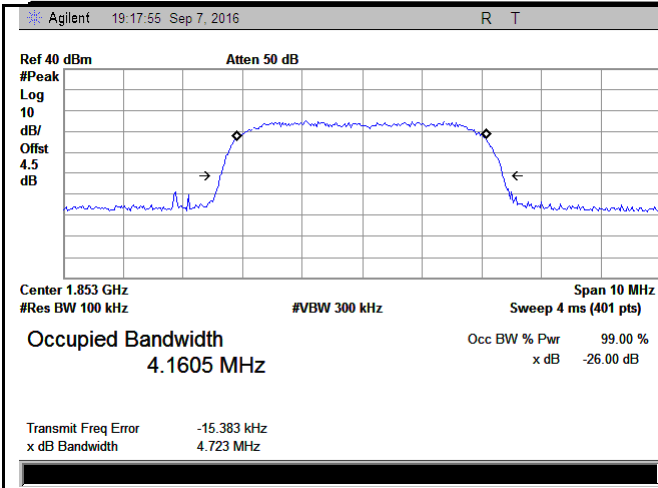

Band II BW - Low CH 1852.4MHz

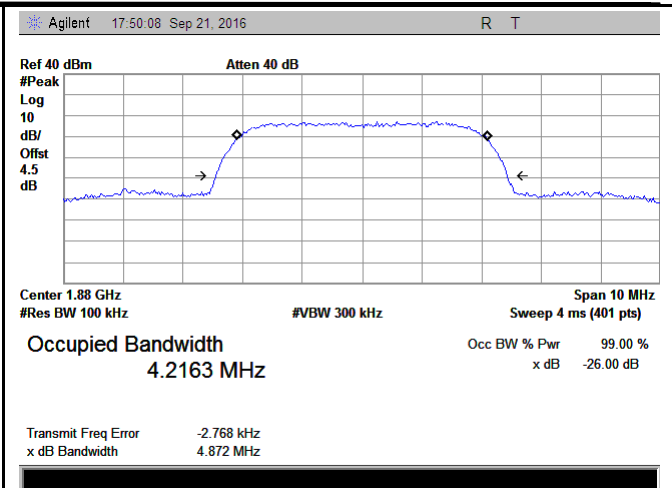

Band II BW - Mid CH 1880MHz

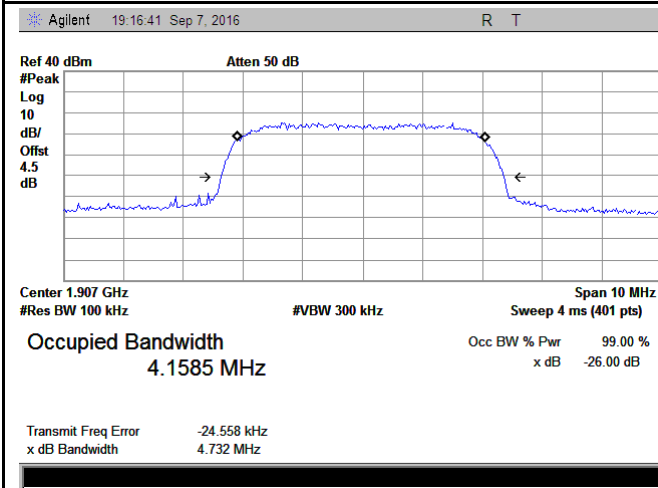

Band II BW - High CH 1907.6MHz

## 6.5 Spurious Emissions at Antenna Terminals

Temperature	24°C
Relative Humidity	59%
Atmospheric Pressure	1007mbar
Test date :	September 07, 2016
Tested By :	Loren Luo

### Requirement(s):

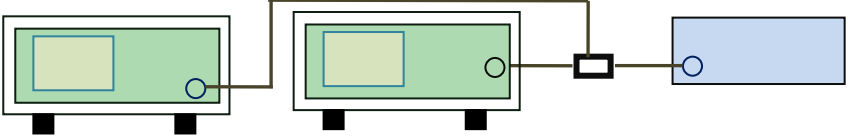
Spec	Item	Requirement	Applicable
§2.1051, §22.917(a)& §24.238(a) § 27.53(h)	a)	The power of any emission outside of the authorized operating frequency ranges must be lower than the transmitter power (P) by a factor of at least $43 + 10 \log (P)$ dB	<input checked="" type="checkbox"/>
Test Setup			
Test Procedure	<ul style="list-style-type: none"> <li>- The EUT was connected to Spectrum Analyzer and Base Station via power divider.</li> <li>- The Band Edges of low and high channels for the highest RF powers were measured.</li> <li>- Setting RBW as roughly BW/100.</li> </ul>		
Remark			
Result	<input checked="" type="checkbox"/> Pass <input type="checkbox"/> Fail		

Test Data     Yes                       N/A  
 Test Plot     Yes (See below)       N/A

**Test Plots**

**GSM Voice:**

**Cellular Band (Part 22H) result**

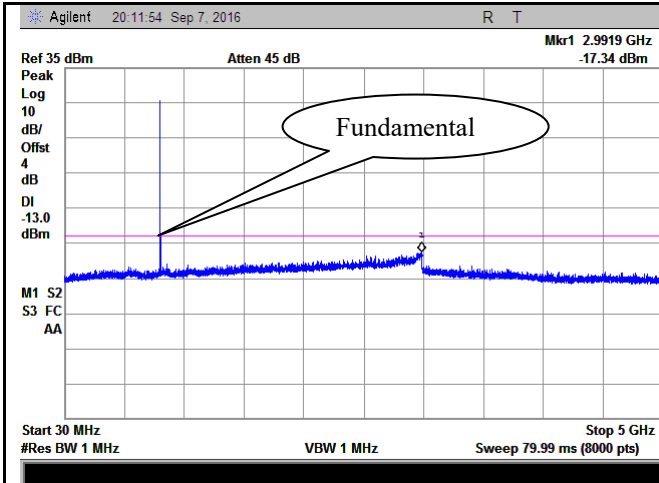

**GSM 850 - Low Channel-1**

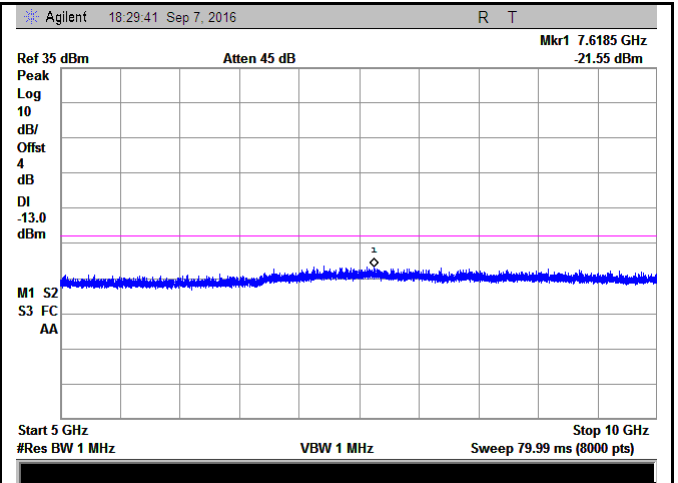

**GSM 850 - Low Channel-2**

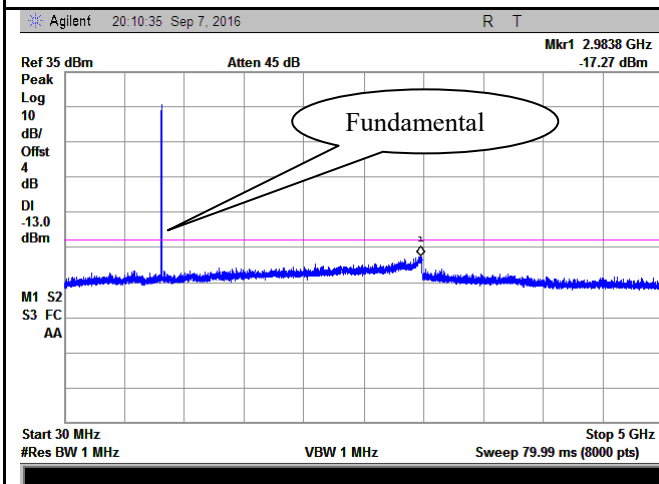

**GSM 850 Middle Channel-1**

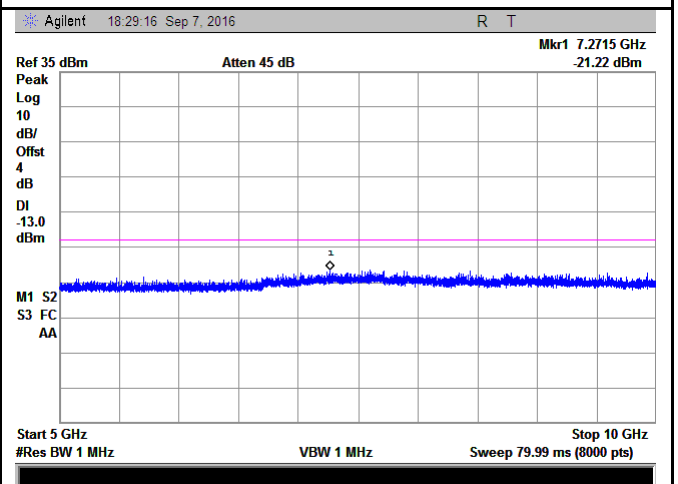

**GSM 850 Middle Channel-2**

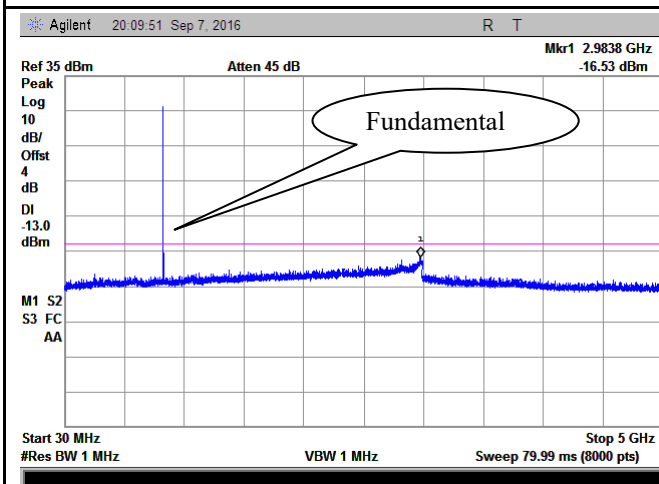

**GSM 850 - High Channel-1**

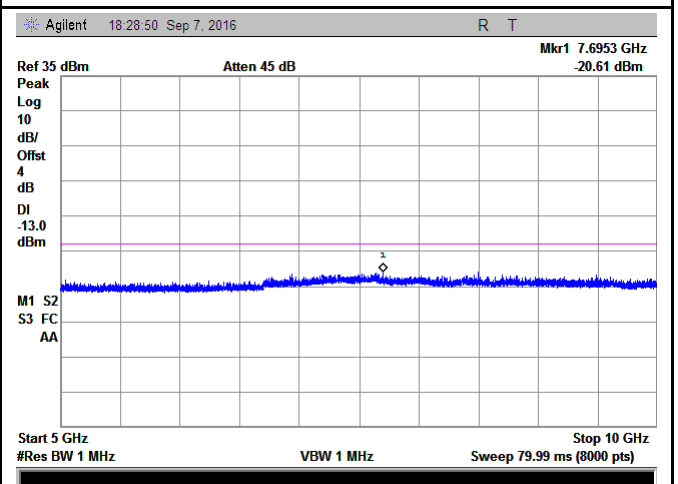

**GSM 850 - High Channel-2**

**PCS Band (Part24E) result**

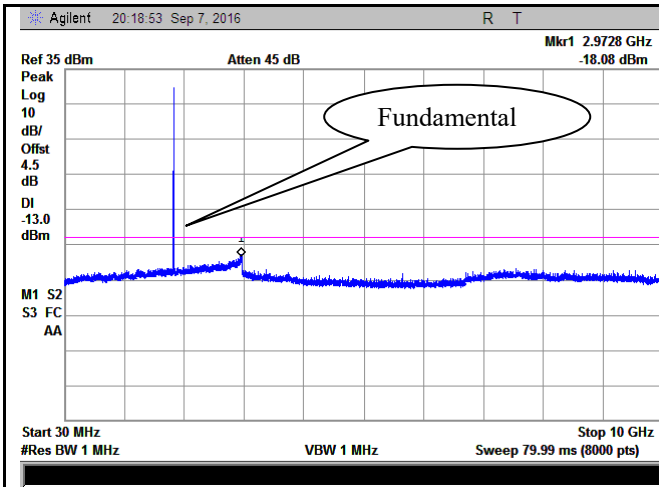

PCS1900 - Low Channel-1

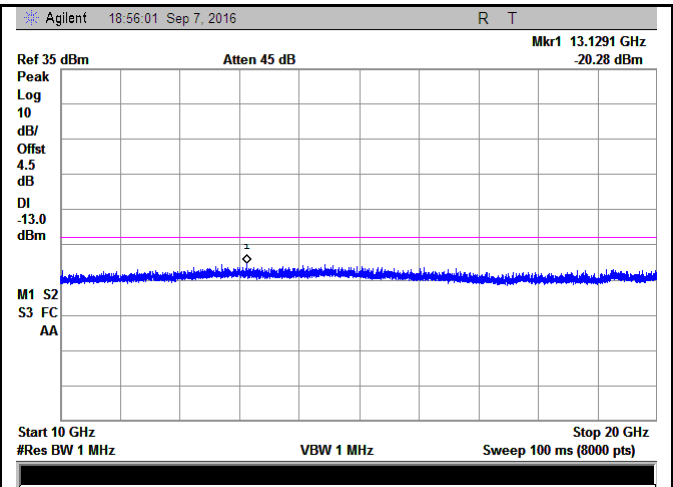

PCS 1900 - Low Channel-2

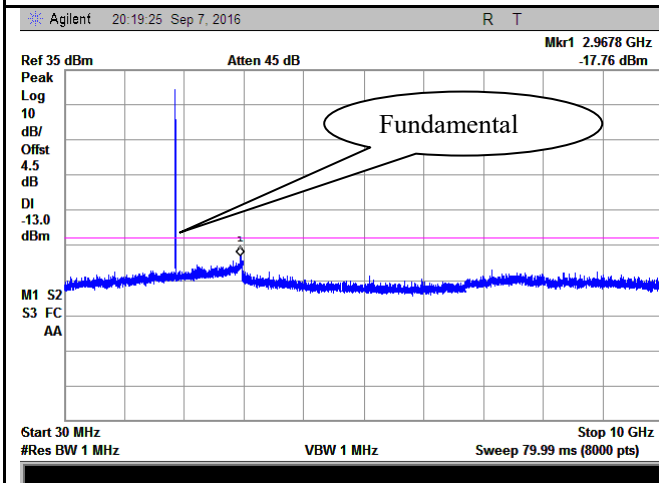

PCS1900 - Middle Channel-1

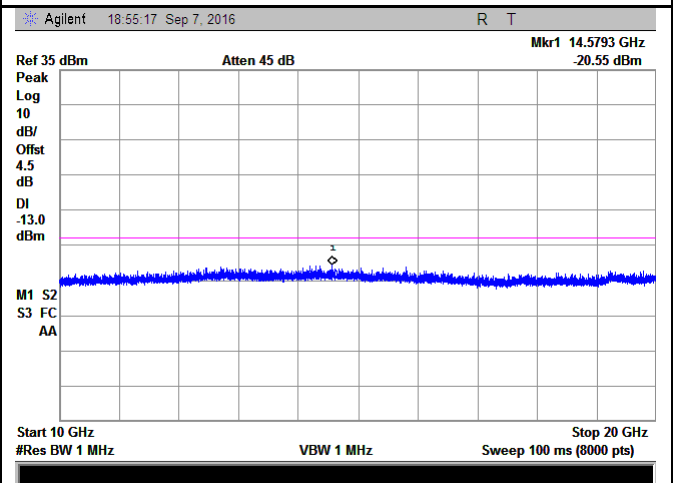

PCS 1900 - Middle Channel-2

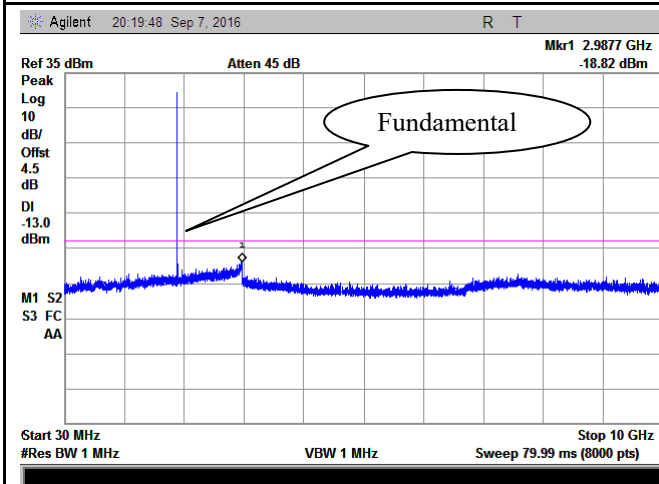

PCS1900 - High Channel-1

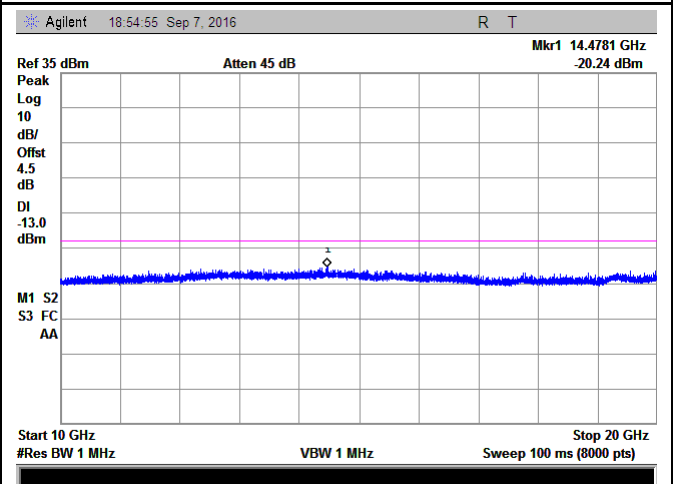

PCS 1900 - High Channel-2

**GPRS:**

**Cellular Band (Part 22H) result**

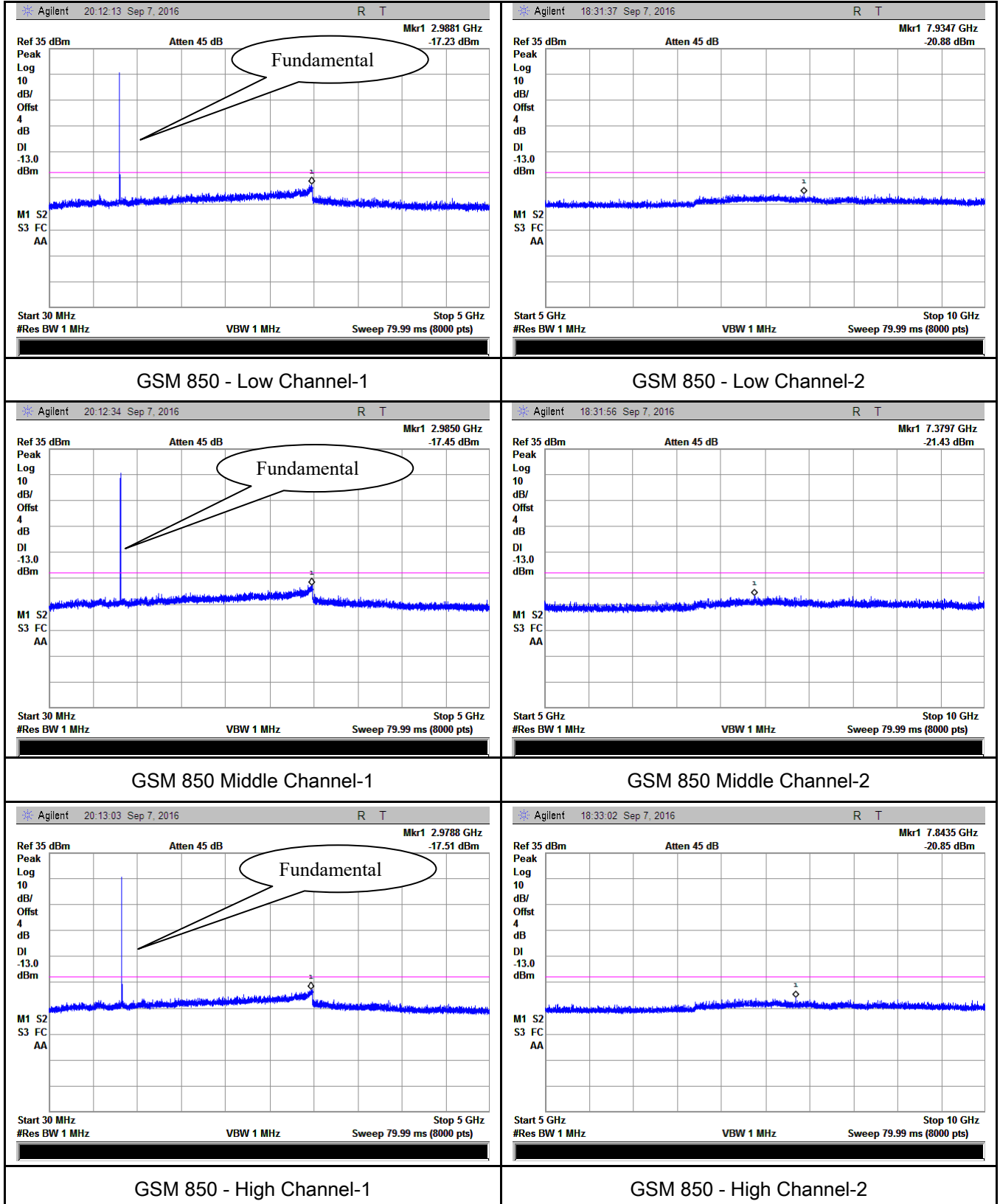

**PCS Band (Part24E) result**

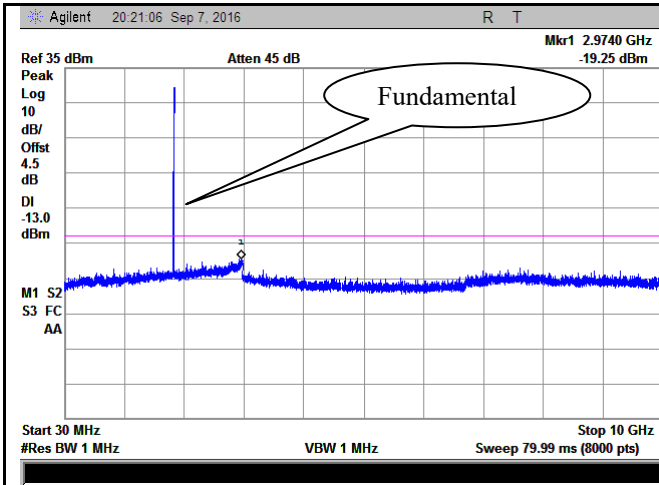

PCS1900 - Low Channel-1

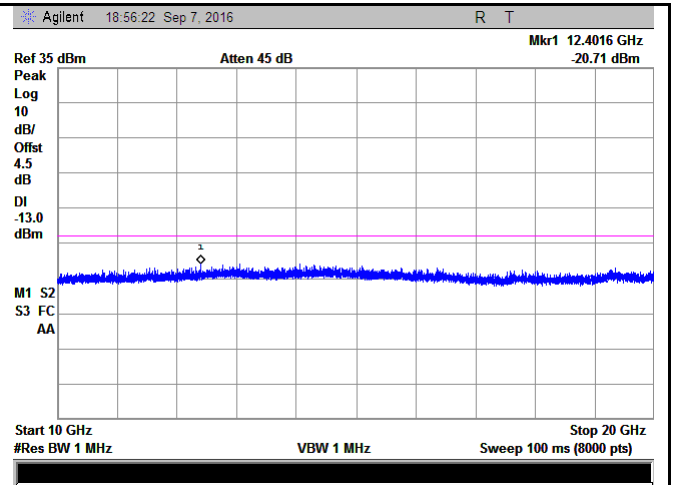

PCS 1900 - Low Channel-2

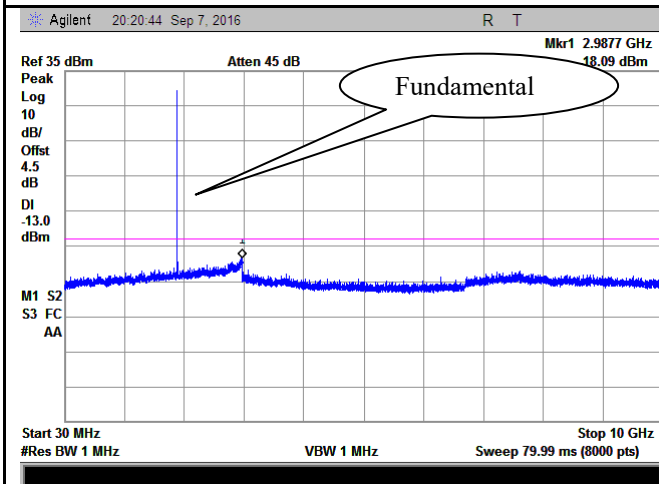

PCS1900 - Middle Channel-1

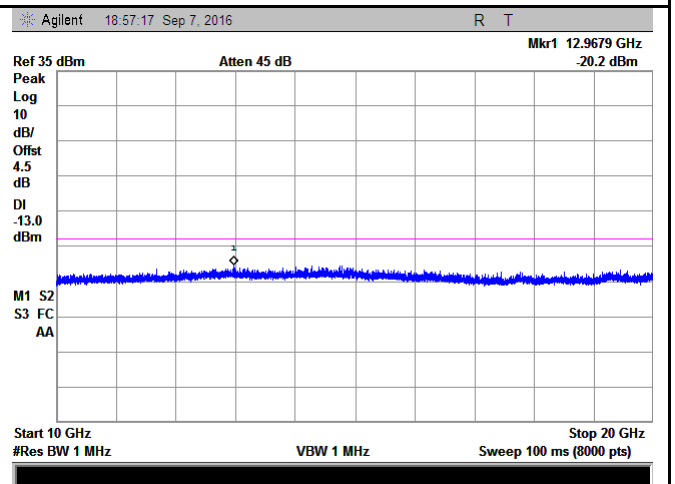

PCS 1900 - Middle Channel-2

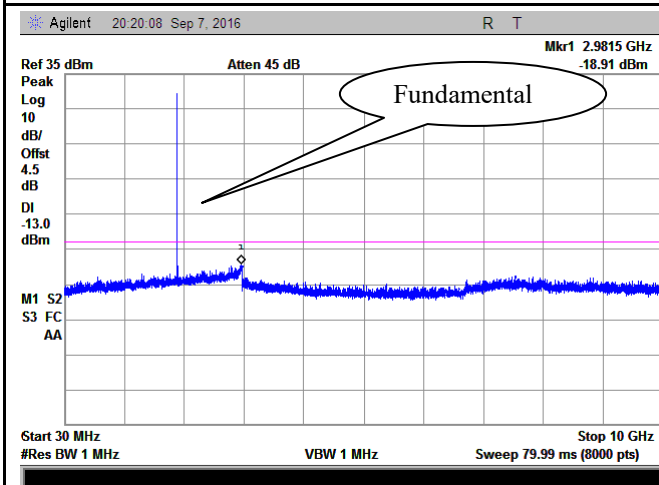

PCS1900 - High Channel-1

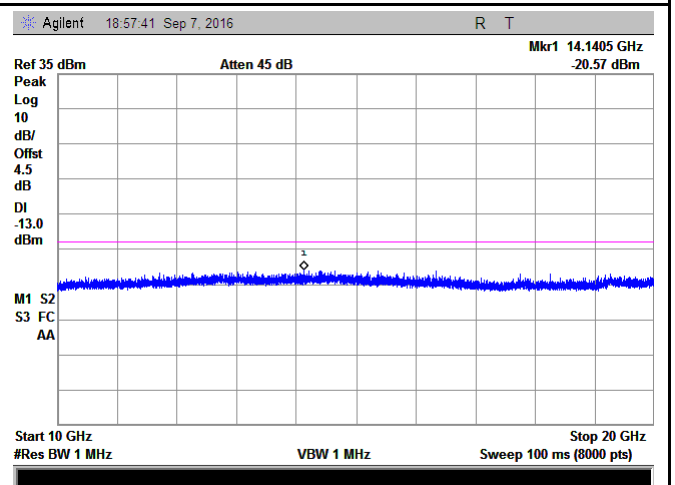

PCS 1900 - High Channel-2

**EGPRS (MCS 1):  
Cellular Band (Part 22H) result**

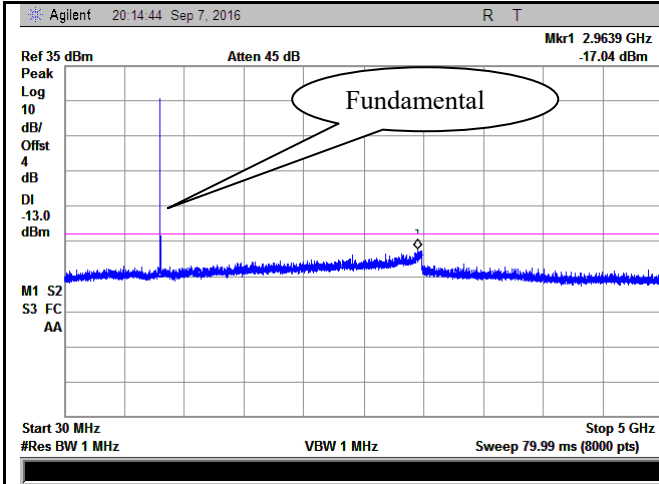

GSM 850 - Low Channel-1

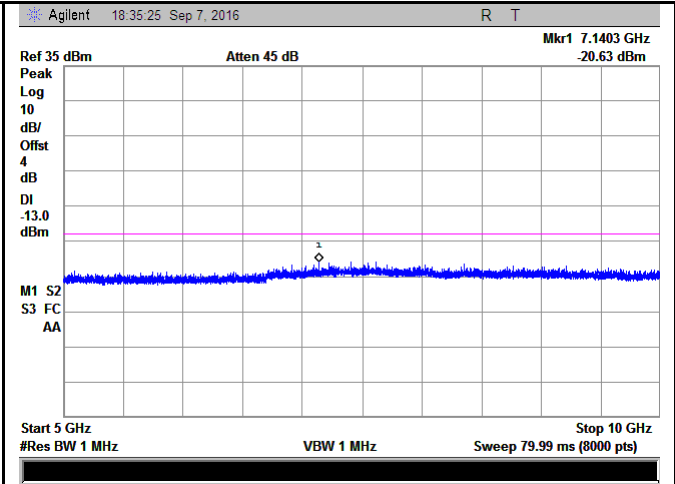

GSM 850 - Low Channel-2

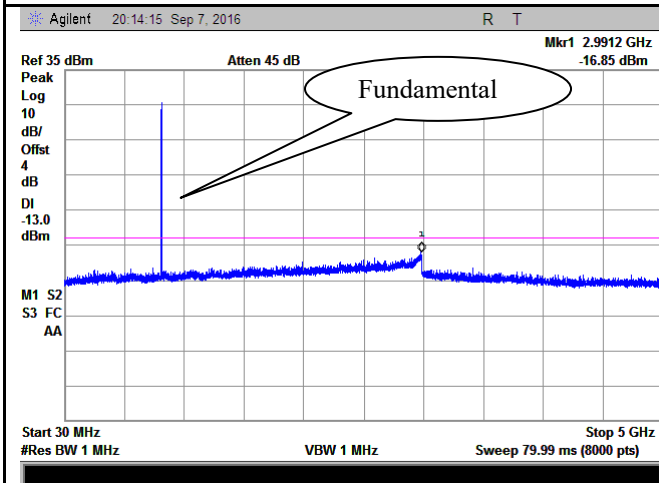

GSM 850 Middle Channel-1

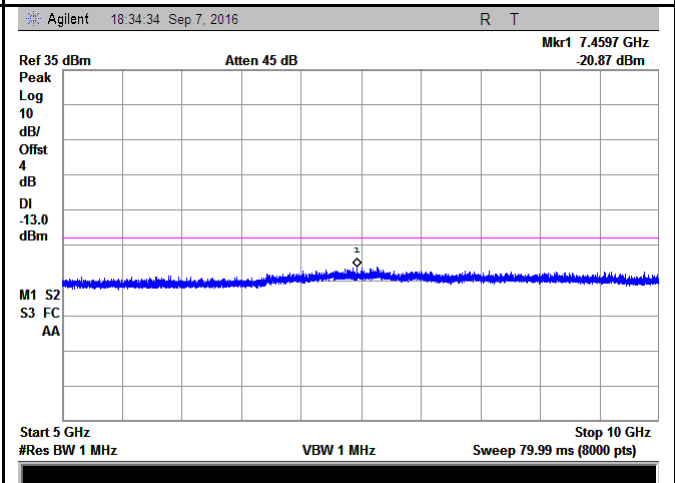

GSM 850 Middle Channel-2

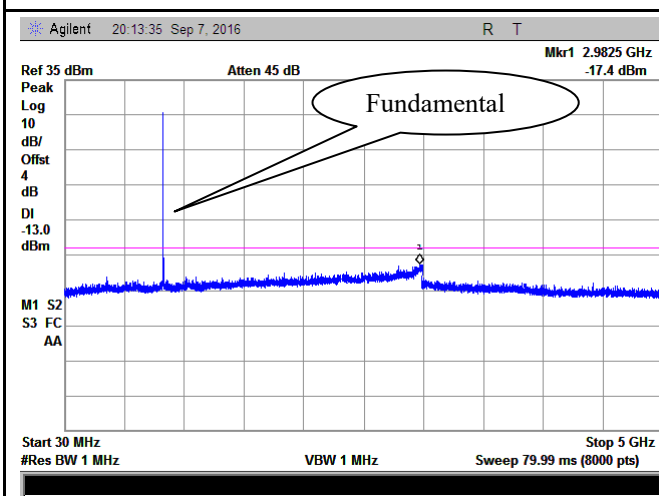

GSM 850 - High Channel-1

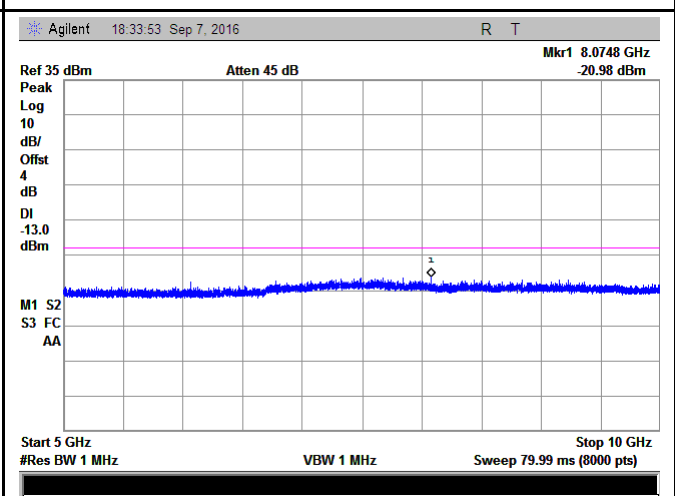

GSM 850 - High Channel-2

### PCS Band (Part24E) result

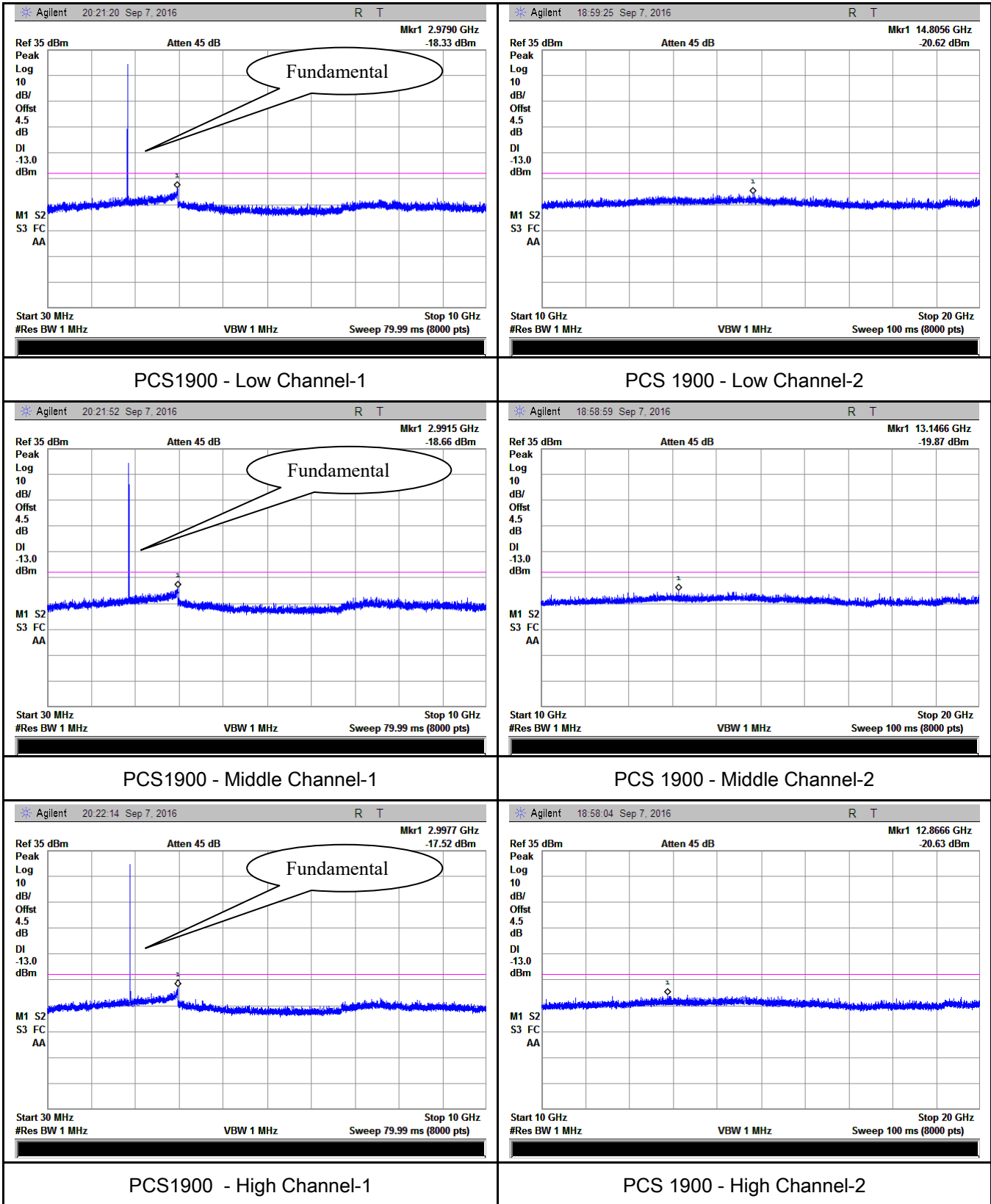

**RMC**

**UMTS-FDD Band V (Part 22H)**

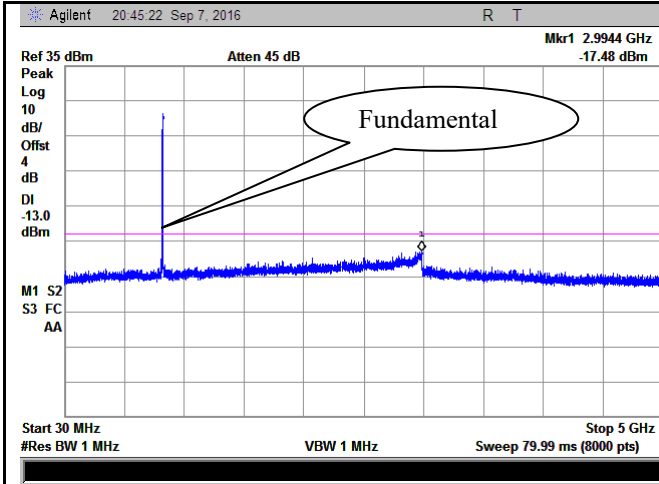

**Band V - Low Channel-1**

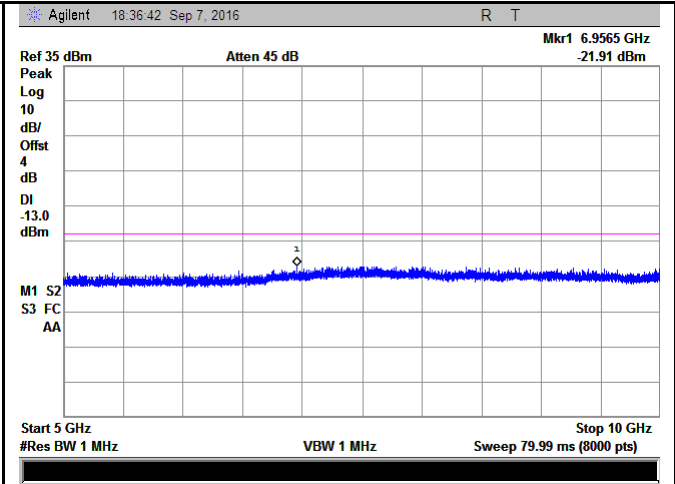

**Band V - Low Channel-2**

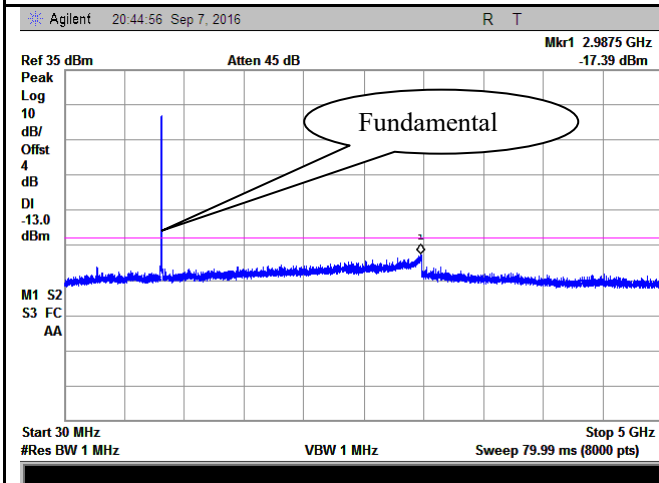

**Band V - Middle Channel-1**

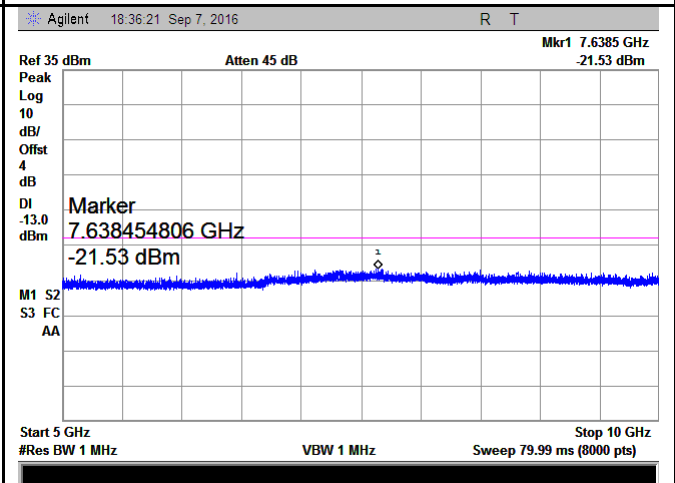

**Band V - Middle Channel-2**

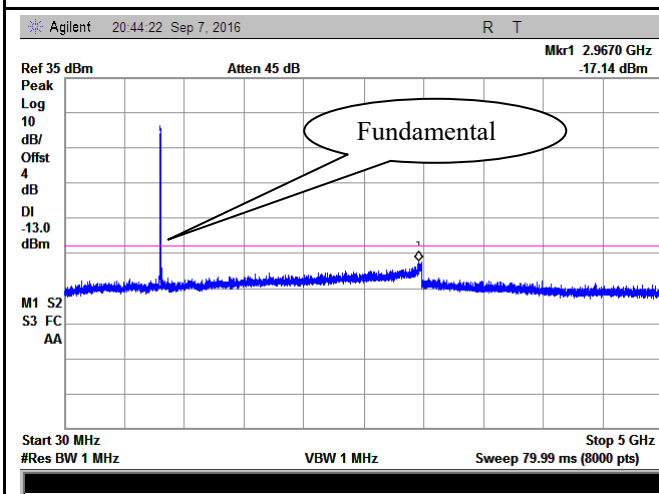

**Band V - High Channel-1**

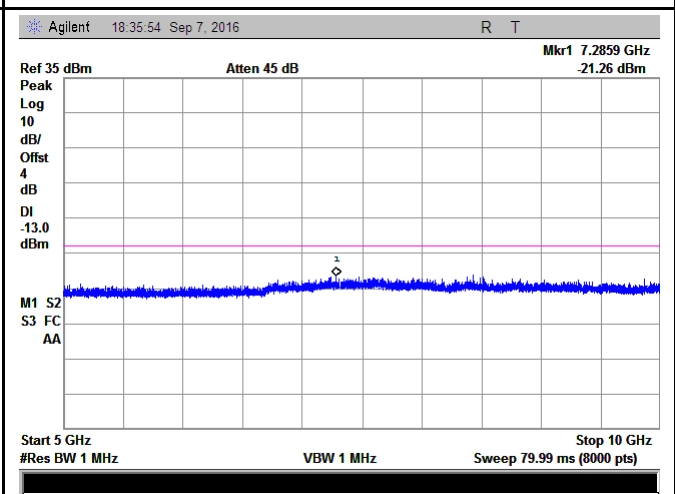

**Band V - High Channel-2**

**UMTS-FDD Band IV (Part 27)**

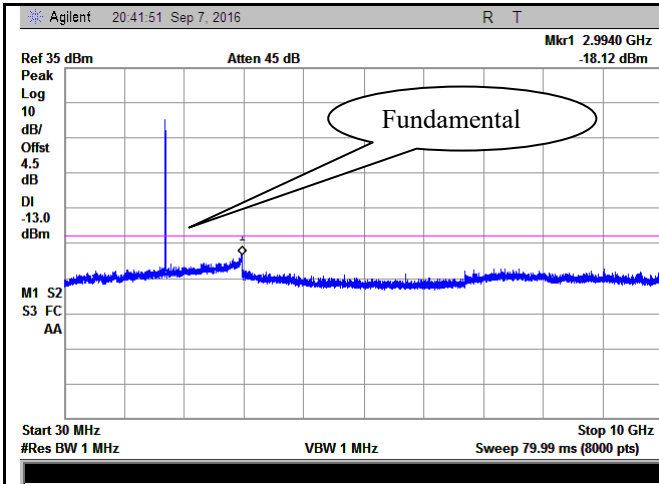

Band IV - Low Channel-1

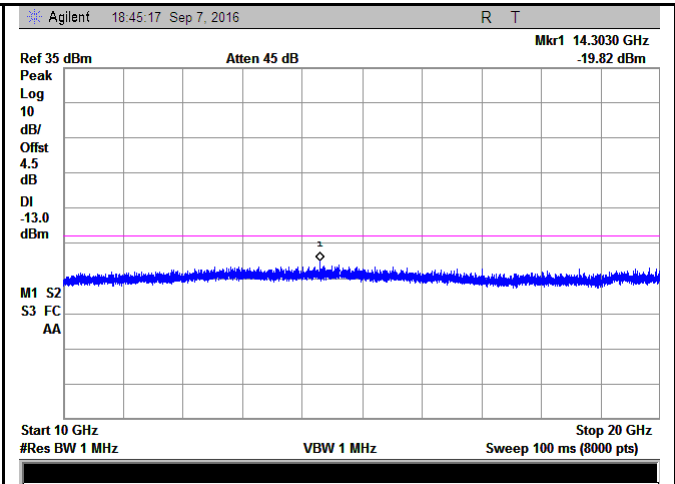

Band IV - Low Channel-2

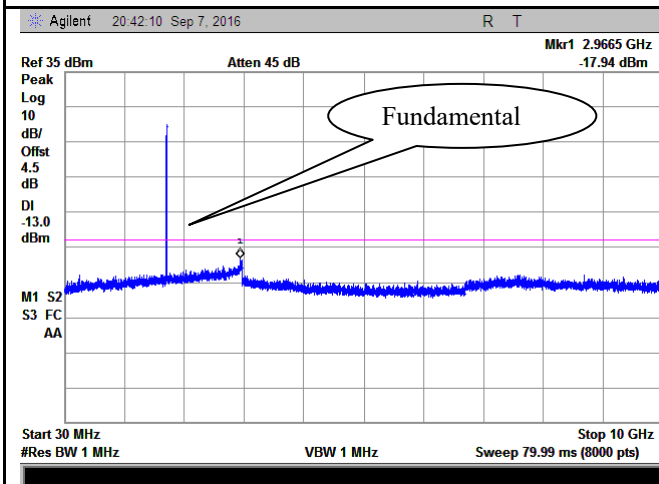

Band IV - Middle Channel-1

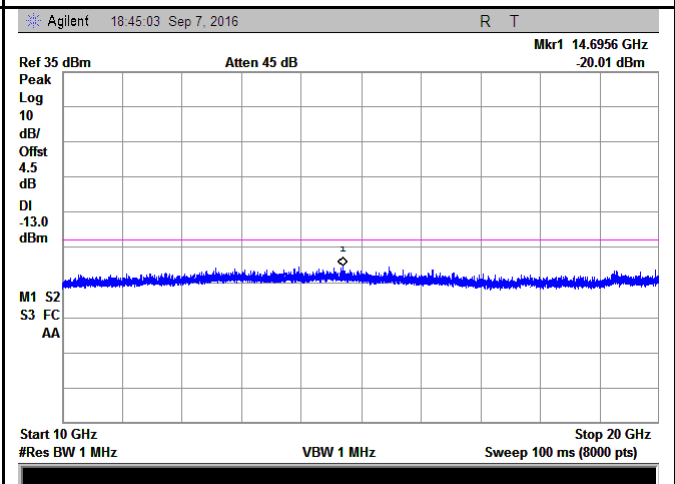

Band IV - Middle Channel-2

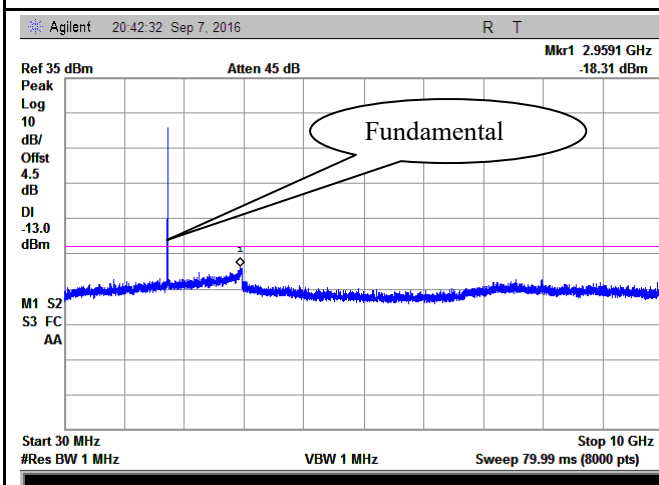

Band IV - High Channel-1

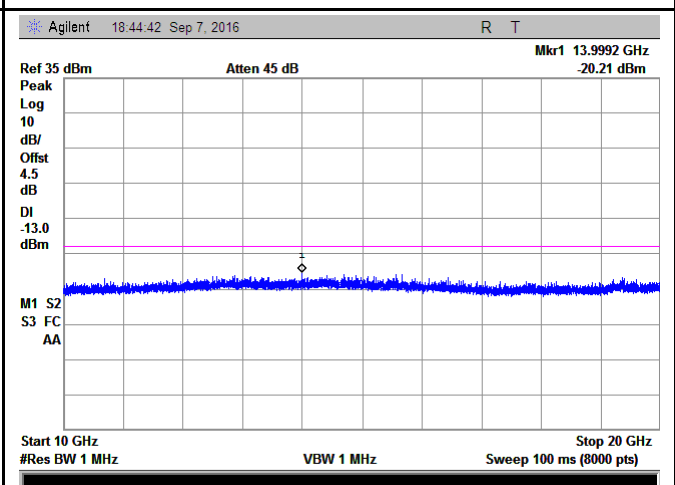

Band IV - High Channel-2

### UMTS-FDD Band II (Part 24E)

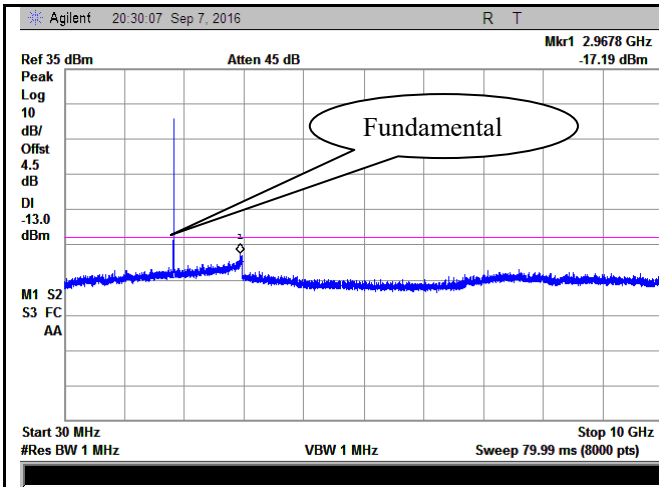

Band II - Low Channel-1

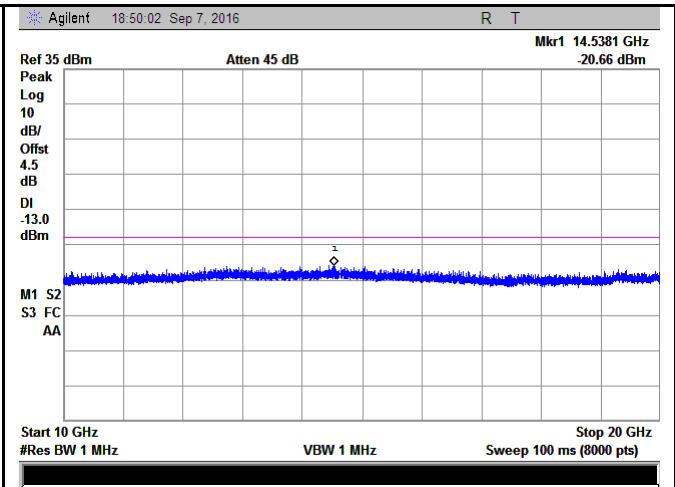

Band II - Low Channel-2

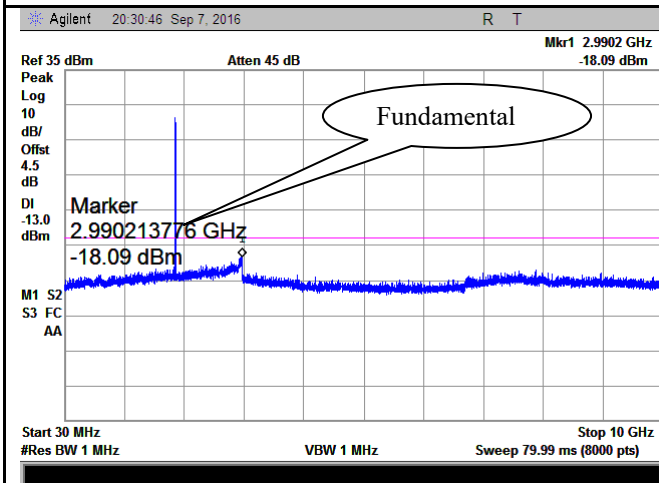

Band II - Middle Channel-1

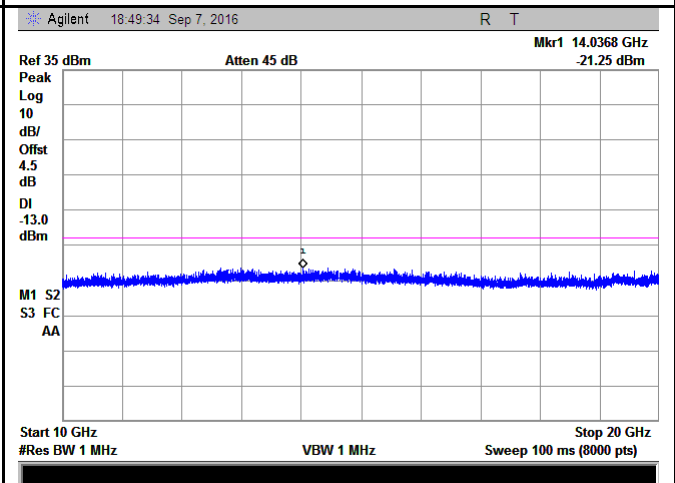

Band II - Middle Channel-2

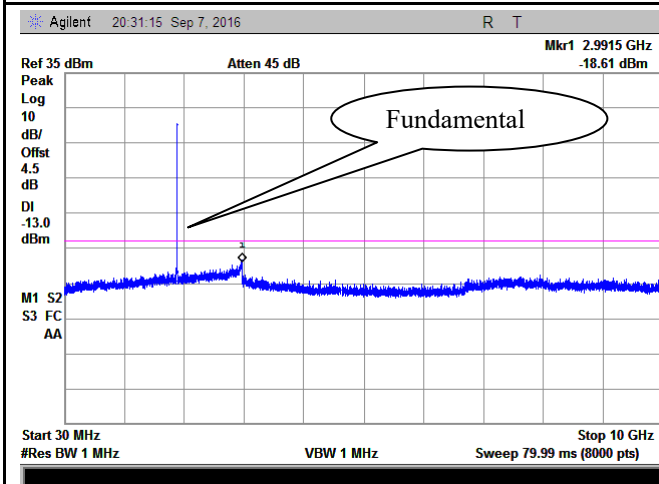

Band II - High Channel-1

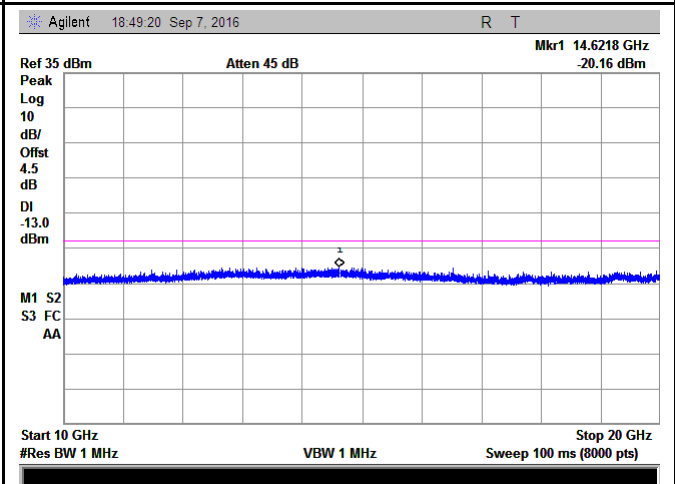

Band II - High Channel-2

**HSUPA:**

**UMTS-FDD Band V (Part 22H)**

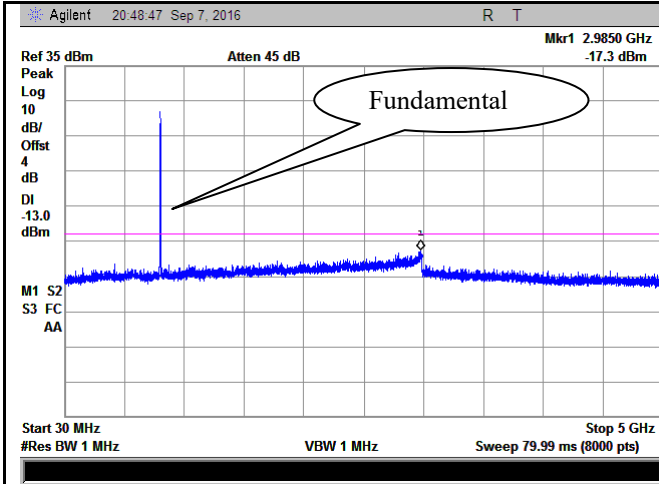

Band V - Low Channel-1

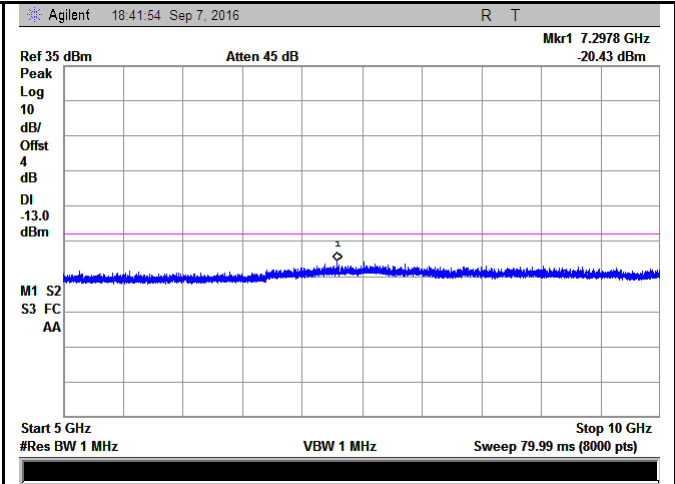

Band V - Low Channel-2

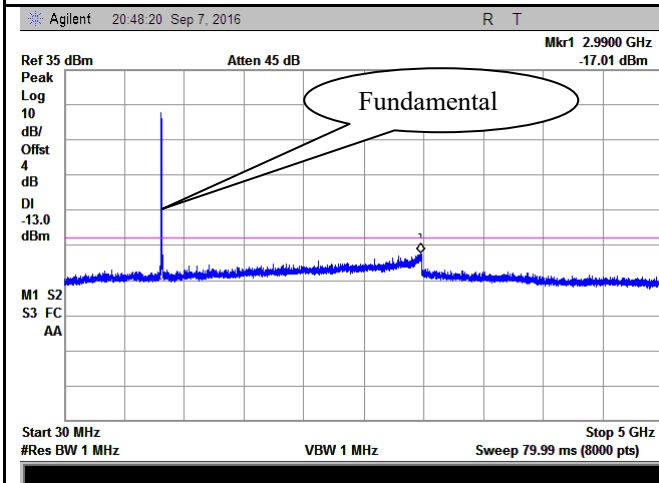

Band V - Middle Channel-1

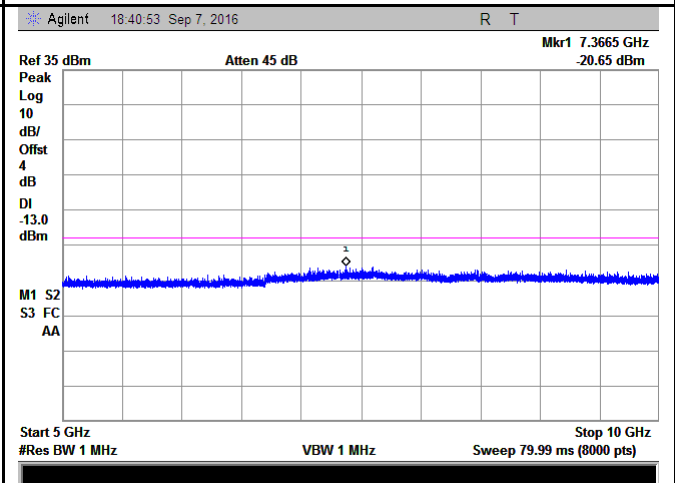

Band V - Middle Channel-2

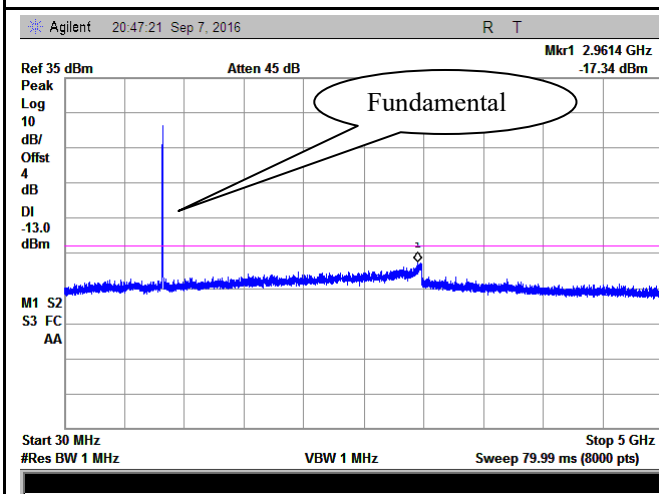

Band V - High Channel-1

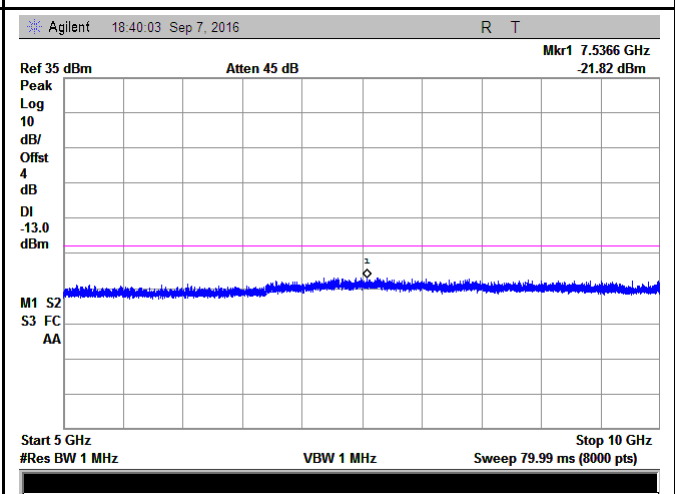

Band V - High Channel-2

**UMTS-FDD Band IV (Part 27)**

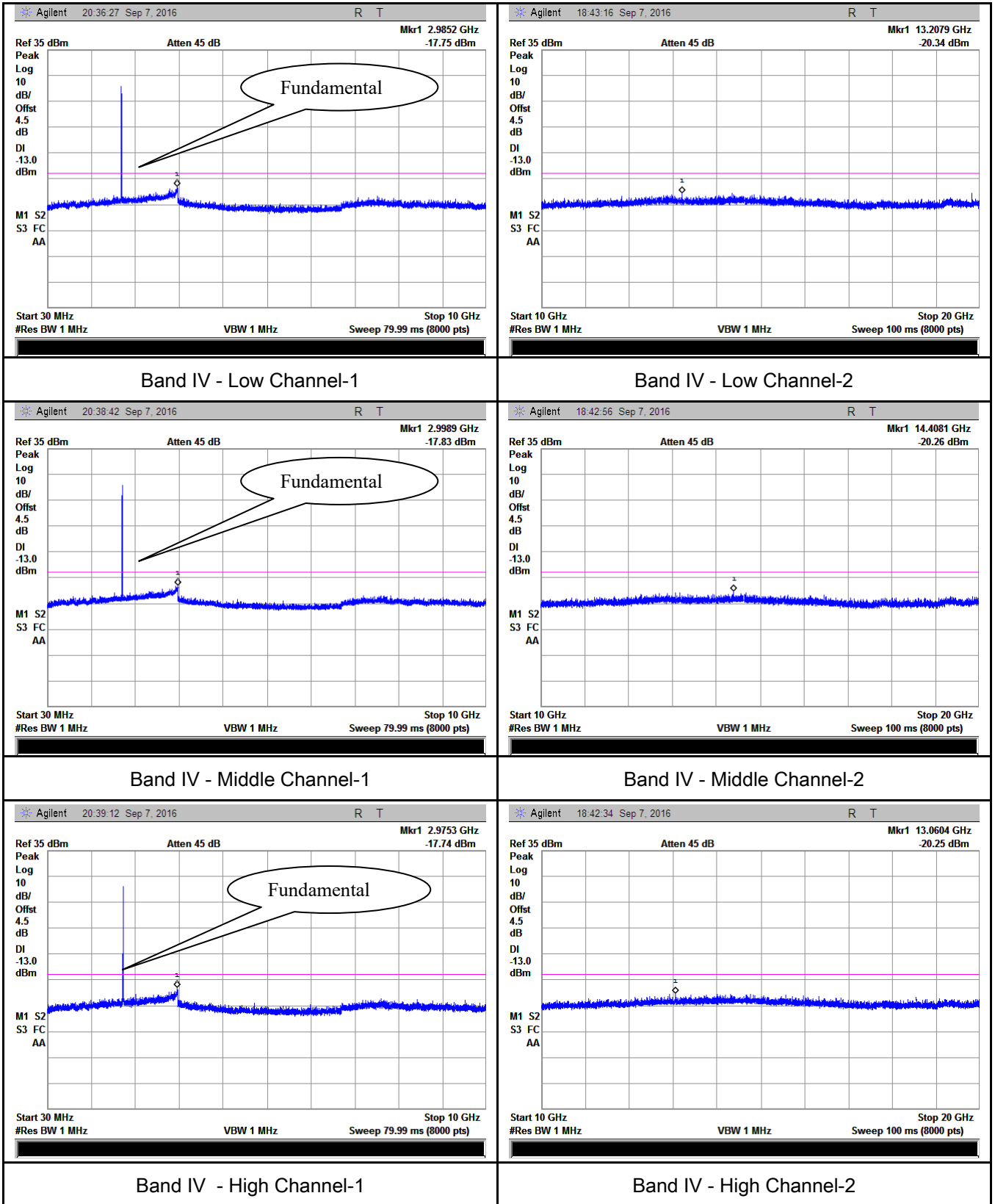

**UMTS-FDD Band II (Part 24E)**

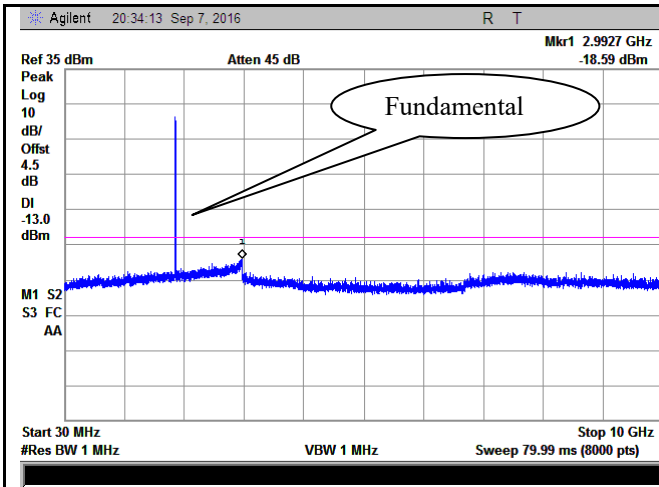

Band II - Low Channel-1

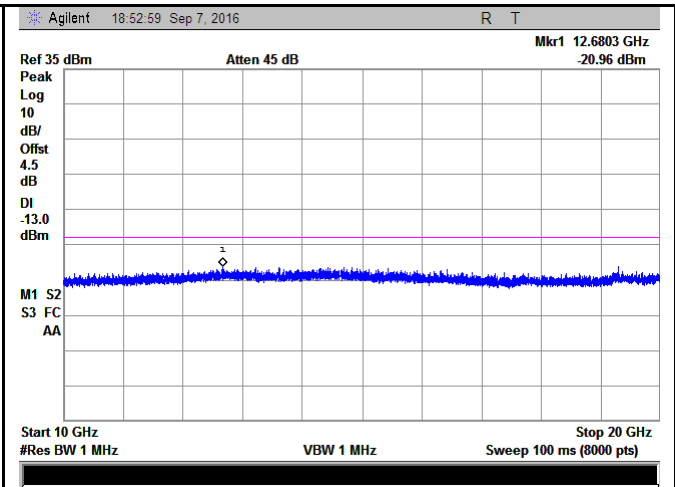

Band II - Low Channel-2

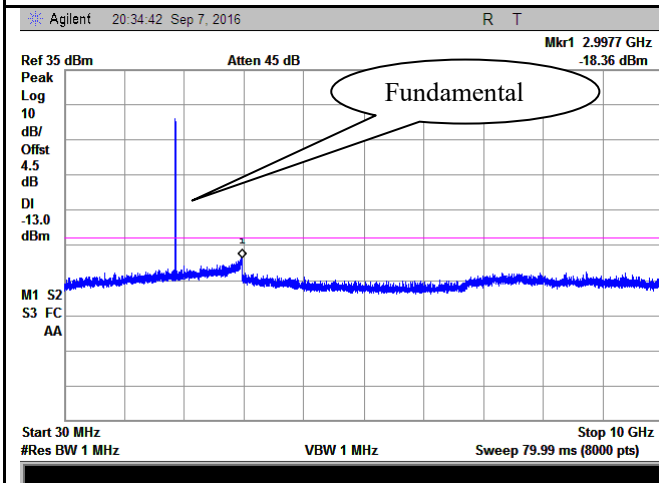

Band II - Middle Channel-1

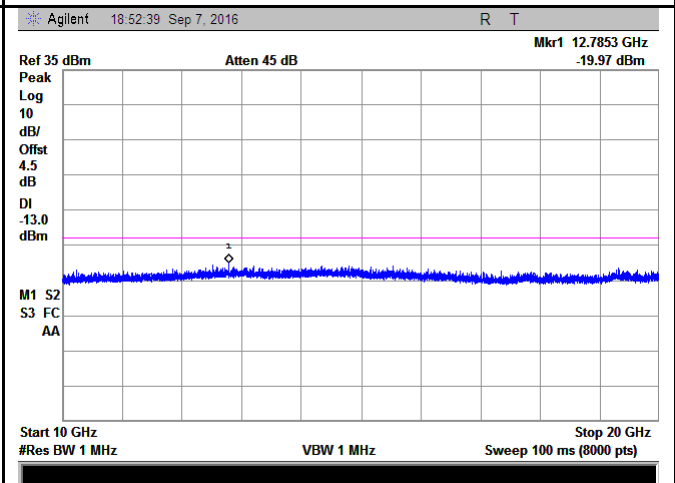

Band II - Middle Channel-2

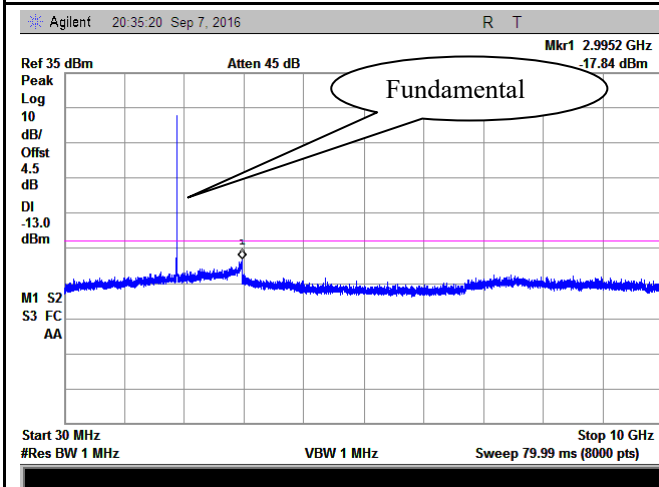

Band II - High Channel-1

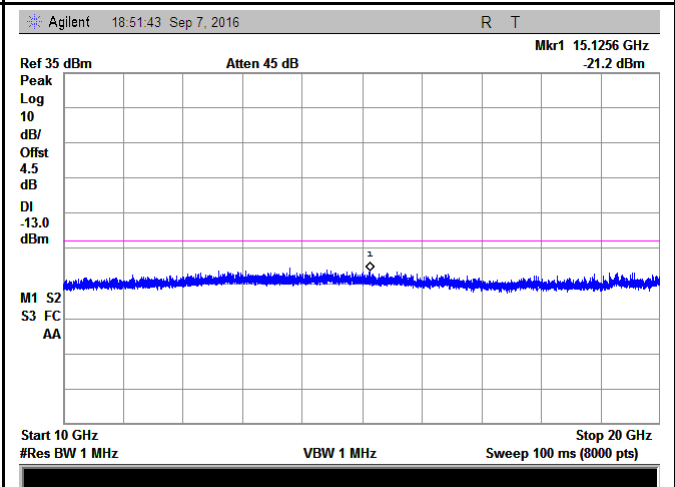

Band II - High Channel-2

**HSDPA:**

**UMTS-FDD Band V (Part 22H)**

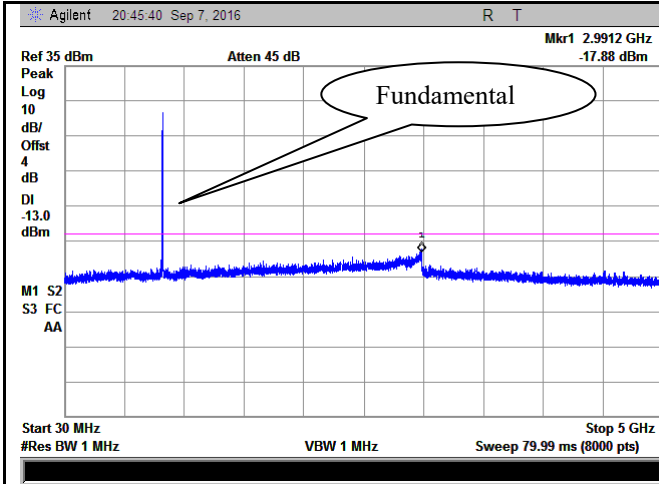

Band V - Low Channel-1

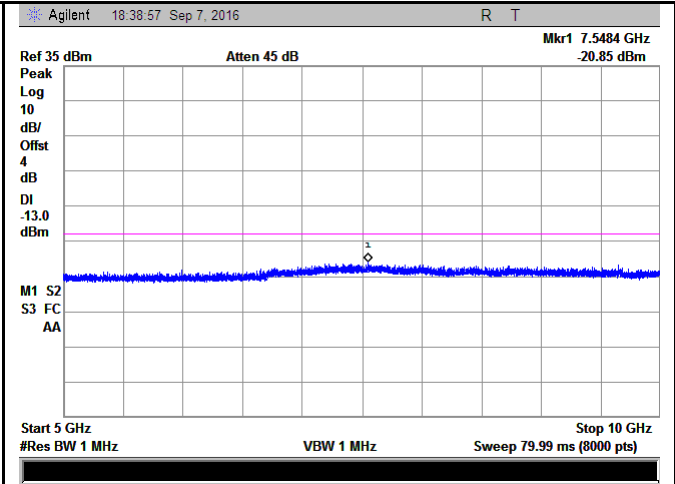

Band V - Low Channel-2

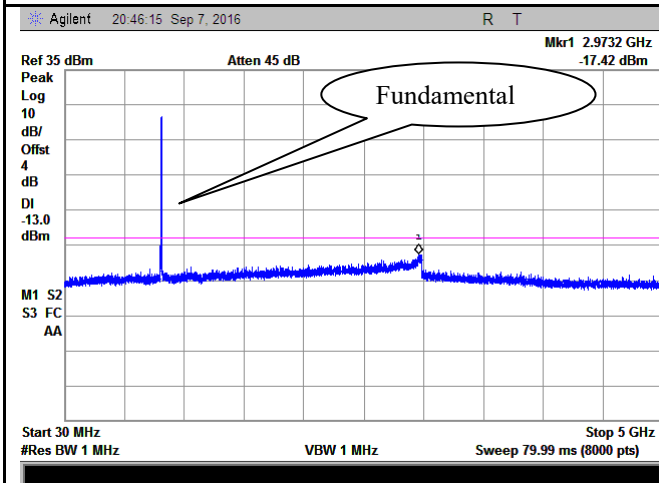

Band V - Middle Channel-1

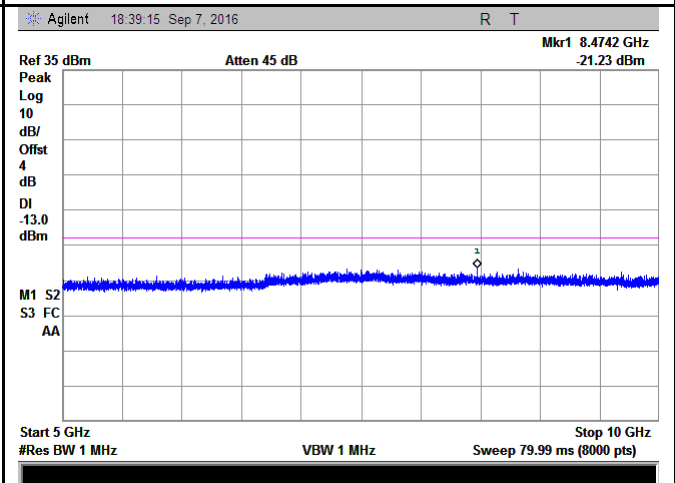

Band V - Middle Channel-2

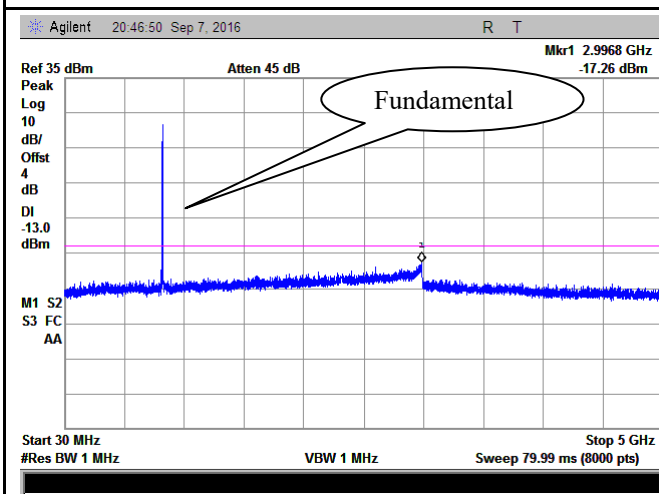

Band V - High Channel-1

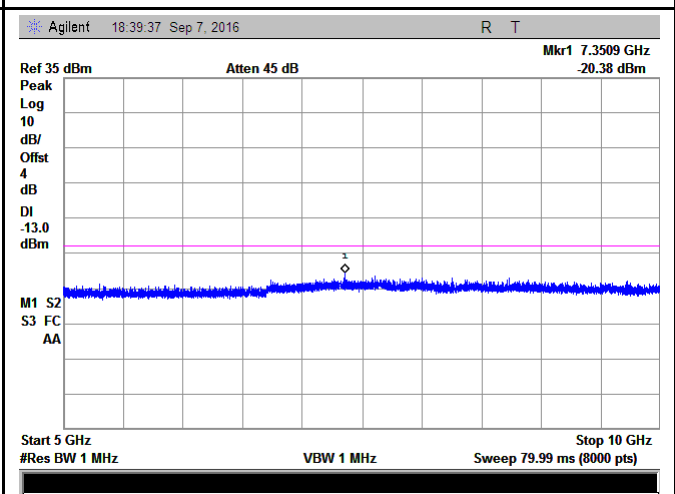

Band V - High Channel-2



**UMTS-FDD Band II (Part 24E)**

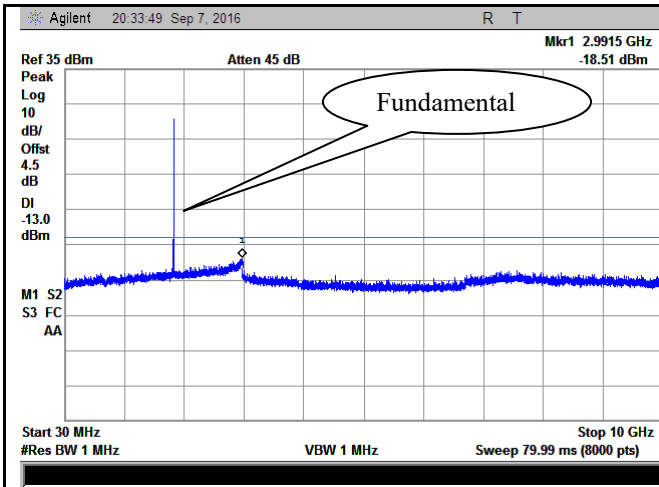

Band II - Low Channel-1

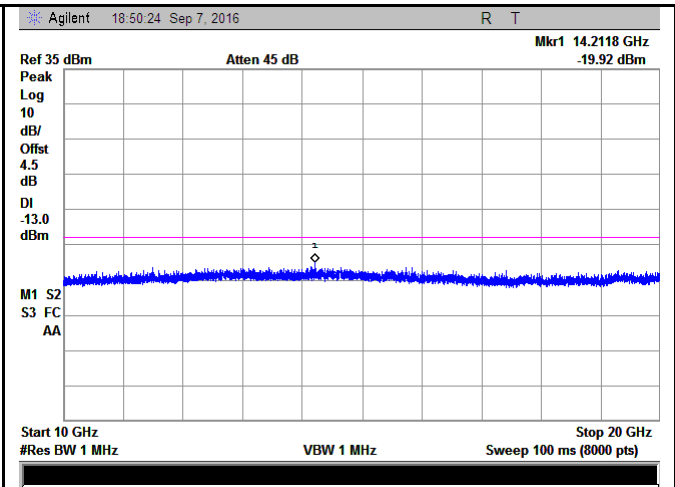

Band II - Low Channel-2

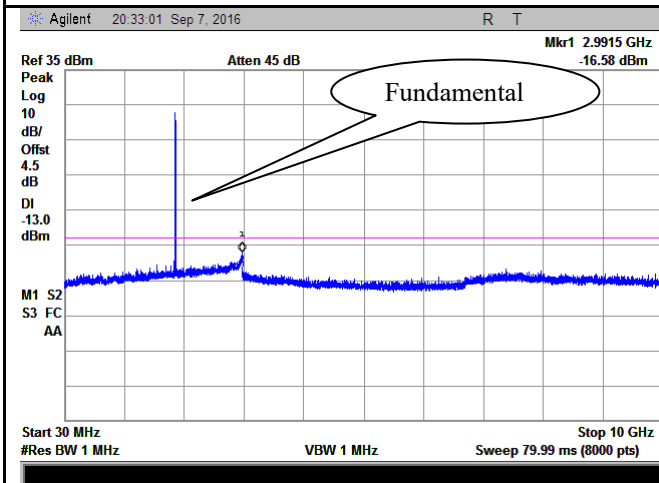

Band II - Middle Channel-1

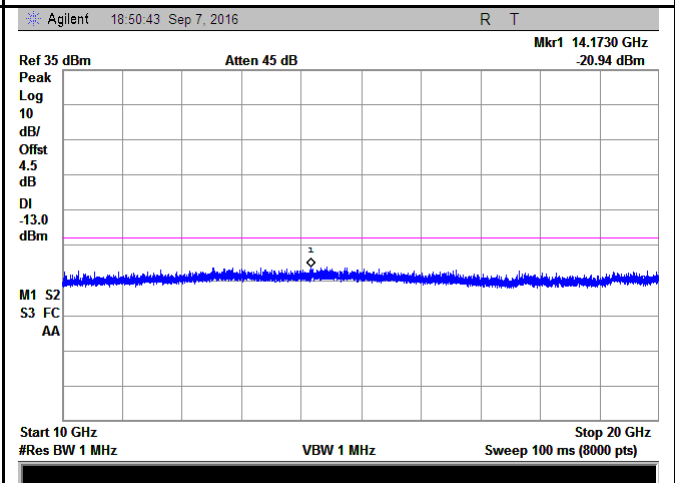

Band II - Middle Channel-2

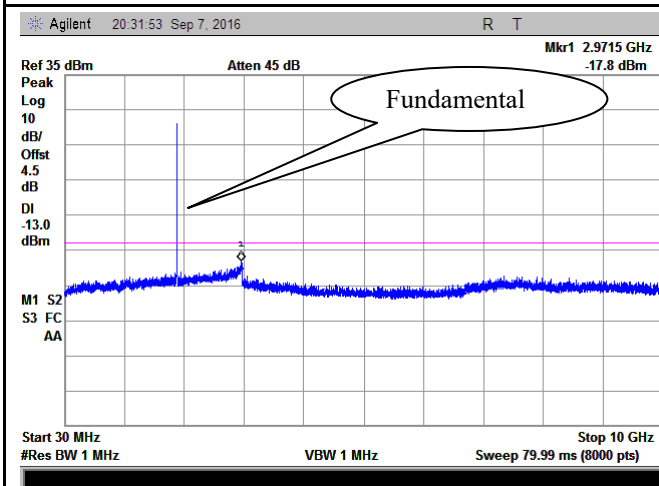

Band II - High Channel-1

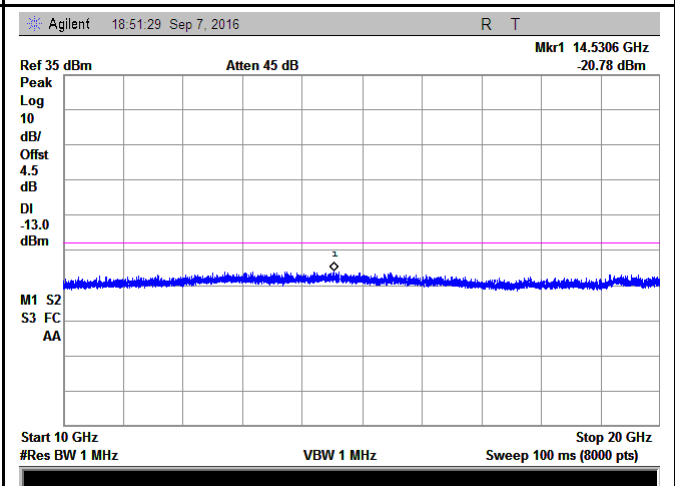

Band II - High Channel-2

## 6.6 Spurious Radiated Emissions

Temperature	22°C
Relative Humidity	55%
Atmospheric Pressure	1013mbar
Test date :	September 13, 2016
Tested By :	Loren Luo

### Requirement(s):

Spec	Item	Requirement	Applicable
§2.1053, §22.917 & §24.238 § 27.53(h)	a)	The power of any emission outside of the authorized operating frequency ranges must be attenuated below the transmitter power (P) by a factor of at least $43 + 10 \log (P)$ dB. The spectrum is scanned from 30 MHz up to a frequency including its 10th harmonic.	<input checked="" type="checkbox"/>

Test setup	
------------	--

Test Procedure	<ol style="list-style-type: none"> <li>The transmitter was placed on a wooden turntable, and it was transmitting into a non-radiating load which was also placed on the turntable.</li> <li>The measurement antenna was placed at a distance of 3 meters from the EUT. During the tests, the antenna height and polarization as well as EUT azimuth were varied in order to identify the maximum level of emissions from the EUT. The test was performed by placing the EUT on 3-orthogonal axis.</li> <li>Remove the EUT and replace it with substitution antenna. A signal generator was connected to the substitution antenna by a non-radiating cable. The absolute levels of the spurious emissions were measured by the substitution. Sample Calculation: EUT Field Strength = Raw Amplitude (dBµV/m) – Amplifier Gain (dB) + Antenna Factor (dB) + Cable Loss (dB) + Filter Attenuation (dB, if used)</li> </ol>
----------------	---

Test Report	16071065-FCC-R1
Page	61 of 104

Remark	
Result	<input checked="" type="checkbox"/> Pass <input type="checkbox"/> Fail

Test Data  Yes  N/A  
 Test Plot  Yes (See below)  N/A

## Cellular Band (Part 22H) result

### Low channel

Frequency (MHz)	Substituted level (dBm)	Polarity (H/V)	Antenna Gain Correction (dB)	Cable Loss (dB)	Corrected Reading (dBm)	Limit (dBm)	Margin (dB)
1648.4	-43.21	V	7.95	0.78	-36.04	-13	-23.04
1648.4	-43.89	H	7.95	0.78	-36.72	-13	-23.72
327.1	-52.34	V	6.4	0.26	-46.2	-13	-33.2
605.3	-52.53	H	6.8	0.37	-46.1	-13	-33.1

### Middle channel

Frequency (MHz)	Substituted level (dBm)	Polarity (H/V)	Antenna Gain Correction (dB)	Cable Loss (dB)	Corrected Reading (dBm)	Limit (dBm)	Margin (dB)
1673.2	-43.16	V	7.95	0.78	-35.99	-13	-22.99
1673.2	-43.85	H	7.95	0.78	-36.68	-13	-23.68
329.5	-52.63	V	6.4	0.26	-46.49	-13	-33.49
603.2	-52.41	H	6.8	0.37	-45.98	-13	-32.98

### High channel

Frequency (MHz)	Substituted level (dBm)	Polarity (H/V)	Antenna Gain Correction (dB)	Cable Loss (dB)	Corrected Reading (dBm)	Limit (dBm)	Margin (dB)
1697.6	-43.26	V	7.95	0.78	-36.09	-13	-23.09
1697.6	-44.03	H	7.95	0.78	-36.86	-13	-23.86
327.4	-52.52	V	6.4	0.26	-46.38	-13	-33.38
602.3	-52.48	H	6.8	0.37	-46.05	-13	-33.05

#### Note:

- 1, The testing has been conformed to  $10 \times 848.8 \text{MHz} = 8,488 \text{MHz}$
- 2, All other emissions more than 30 dB below the limit
- 3, GSM voice, GPRS and EGPRS mode were investigated. The results above show only the worse cases
- 4, X-Axis, Y-Axis and Z-Axis were investigated. The results above show only the worst case.

## PCS Band (Part24E) result

### Low channel

Frequency (MHz)	Substituted level (dBm)	Polarity (H/V)	Antenna Gain Correction (dB)	Cable Loss (dB)	Corrected Reading (dBm)	Limit (dBm)	Margin (dB)
3700.4	-48.55	V	10.25	2.73	-41.03	-13	-28.03
3700.4	-48.95	H	10.25	2.73	-41.43	-13	-28.43
329.8	-53.39	V	6.4	0.26	-47.25	-13	-34.25
606.5	-53.69	H	6.8	0.37	-47.26	-13	-34.26

### Middle channel

Frequency (MHz)	Substituted level (dBm)	Polarity (H/V)	Antenna Gain Correction (dB)	Cable Loss (dB)	Corrected Reading (dBm)	Limit (dBm)	Margin (dB)
3760	-48.63	V	10.25	2.73	-41.11	-13	-28.11
3760	-49.25	H	10.25	2.73	-41.73	-13	-28.73
326.1	-52.98	V	6.4	0.26	-46.84	-13	-33.84
601.7	-53.48	H	6.8	0.37	-47.05	-13	-34.05

### High channel

Frequency (MHz)	Substituted level (dBm)	Polarity (H/V)	Antenna Gain Correction (dB)	Cable Loss (dB)	Corrected Reading (dBm)	Limit (dBm)	Margin (dB)
3819.6	-48.62	V	10.36	2.73	-40.99	-13	-27.99
3819.6	-49.21	H	10.36	2.73	-41.58	-13	-28.58
328.4	-53.44	V	6.4	0.26	-47.3	-13	-34.3
603.9	-51.36	H	6.8	0.37	-44.93	-13	-31.93

#### Note:

- 1, The testing has been conformed to  $10 \times 1909.8 \text{ MHz} = 19,098 \text{ MHz}$
- 2, All other emissions more than 30 dB below the limit
- 3, GSM voice, GPRS and EGPRS mode were investigated. The results above show only the worse cases
- 4, X-Axis, Y-Axis and Z-Axis were investigated. The results above show only the worst case.

## UMTS-FDD Band V (Part 22H)

### Low channel

Frequency (MHz)	Substituted level (dBm)	Polarity (H/V)	Antenna Gain Correction (dB)	Cable Loss (dB)	Corrected Reading (dBm)	Limit (dBm)	Margin (dB)
1652.8	-46.12	V	7.95	0.78	-38.95	-13	-25.95
1652.8	-45.68	H	7.95	0.78	-38.51	-13	-25.51
330.5	-52.78	V	6.4	0.26	-46.64	-13	-33.64
601.9	-53.06	H	6.8	0.37	-46.63	-13	-33.63

### Middle channel

Frequency (MHz)	Substituted level (dBm)	Polarity (H/V)	Antenna Gain Correction (dB)	Cable Loss (dB)	Corrected Reading (dBm)	Limit (dBm)	Margin (dB)
1670	-46.18	V	7.95	0.78	-39.01	-13	-26.01
1670	-45.79	H	7.95	0.78	-38.62	-13	-25.62
328.7	-52.36	V	6.4	0.26	-46.22	-13	-33.22
604.5	-52.62	H	6.8	0.37	-46.19	-13	-33.19

### High channel

Frequency (MHz)	Substituted level (dBm)	Polarity (H/V)	Antenna Gain Correction (dB)	Cable Loss (dB)	Corrected Reading (dBm)	Limit (dBm)	Margin (dB)
1693.2	-46.27	V	7.95	0.78	-39.1	-13	-26.1
1693.2	-45.68	H	7.95	0.78	-38.51	-13	-25.51
329.6	-52.78	V	6.4	0.26	-46.64	-13	-33.64
602.1	-53.11	H	6.8	0.37	-46.68	-13	-33.68

**Note:**

- 1, The testing has been conformed to  $10 \times 846.6 \text{MHz} = 8,466 \text{MHz}$
- 2, All other emissions more than 30 dB below the limit
- 3, RMC, HSUPA and HSDPA mode were investigated. The results above show only the worse cases
- 4, X-Axis, Y-Axis and Z-Axis were investigated. The results above show only the worst case.

## UMTS-FDD Band II (Part 24E)

### Low channel

Frequency (MHz)	Substituted level (dBm)	Polarity (H/V)	Antenna Gain Correction (dB)	Cable Loss (dB)	Corrected Reading (dBm)	Limit (dBm)	Margin (dB)
3704.8	-49.41	V	10.25	2.73	-41.89	-13	-28.89
3704.8	-50.13	H	10.25	2.73	-42.61	-13	-29.61
329.5	-53.24	V	6.4	0.26	-47.1	-13	-34.1
601.4	-53.06	H	6.8	0.37	-46.63	-13	-33.63

### Middle channel

Frequency (MHz)	Substituted level (dBm)	Polarity (H/V)	Antenna Gain Correction (dB)	Cable Loss (dB)	Corrected Reading (dBm)	Limit (dBm)	Margin (dB)
3760	-49.36	V	10.25	2.73	-41.84	-13	-28.84
3760	-49.58	H	10.25	2.73	-42.06	-13	-29.06
328.7	-53.55	V	6.4	0.26	-47.41	-13	-34.41
603.4	-53.17	H	6.8	0.37	-46.74	-13	-33.74

### High channel

Frequency (MHz)	Substituted level (dBm)	Polarity (H/V)	Antenna Gain Correction (dB)	Cable Loss (dB)	Corrected Reading (dBm)	Limit (dBm)	Margin (dB)
3815.2	-49.25	V	10.36	2.73	-41.62	-13	-28.62
3815.2	-49.56	H	10.36	2.73	-41.93	-13	-28.93
330.2	-53.28	V	6.4	0.26	-47.14	-13	-34.14
604.5	-53.71	H	6.8	0.37	-47.28	-13	-34.28

**Note:**

- 1, The testing has been conformed to  $10 \times 1907.6 \text{ MHz} = 19,076 \text{ MHz}$
- 2, All other emissions more than 30 dB below the limit
- 3, RMC, HSUPA and HSDPA mode were investigated. The results above show only the worse cases
- 4, X-Axis, Y-Axis and Z-Axis were investigated. The results above show only the worst case

## UMTS-FDD Band IV (Part 27E)

### Low channel

Frequency (MHz)	Substituted level (dBm)	Polarity (H/V)	Antenna Gain Correction (dB)	Cable Loss (dB)	Corrected Reading (dBm)	Limit (dBm)	Margin (dB)
3424.8	-46.11	V	10.07	2.52	-38.56	-13	-25.56
3424.8	-45.93	H	10.07	2.52	-38.38	-13	-25.38
324.5	-57.14	V	6.4	0.26	-51	-13	-38
738.6	-52.68	H	7.1	0.42	-46	-13	-33

### Middle channel

Frequency (MHz)	Substituted level (dBm)	Polarity (H/V)	Antenna Gain Correction (dB)	Cable Loss (dB)	Corrected Reading (dBm)	Limit (dBm)	Margin (dB)
3480	-46.23	V	10.09	2.52	-38.66	-13	-25.66
3480	-45.72	H	10.09	2.52	-38.15	-13	-25.15
322.4	-56.84	V	6.4	0.26	-50.7	-13	-37.7
736.3	-53.26	H	7.1	0.42	-46.58	-13	-33.58

### High channel

Frequency (MHz)	Substituted level (dBm)	Polarity (H/V)	Antenna Gain Correction (dB)	Cable Loss (dB)	Corrected Reading (dBm)	Limit (dBm)	Margin (dB)
3505.2	-45.79	V	10.09	2.52	-38.22	-13	-25.22
3505.2	-45.06	H	10.09	2.52	-37.49	-13	-24.49
325.7	-57.01	V	6.4	0.26	-50.87	-13	-37.87
737.8	-52.94	H	7.1	0.42	-46.26	-13	-33.26

**Note:**

1, The testing has been conformed to  $10 \times 1712.4 \text{ MHz} = 17,124 \text{ MHz}$

2, All other emissions more than 30 dB below the limit

3, RMC, HSUPA and HSDPA mode were investigated. The results above show only the worse cases

4, X-Axis, Y-Axis and Z-Axis were investigated. The results above show only the worst case

## 6.7 Band Edge

Temperature	24°C
Relative Humidity	59%
Atmospheric Pressure	1007mbar
Test date :	September 07, 2016
Tested By :	Loren Luo

### Requirement(s):

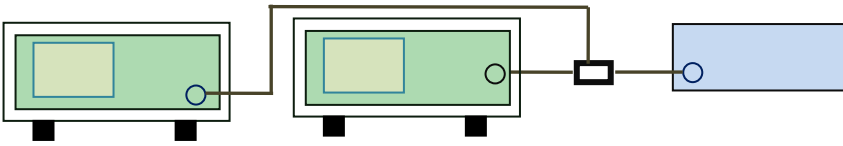
Spec	Item	Requirement	Applicable
§22.917(a) §24.238(a) § 27.53(h)	a)	The power of any emission outside of the authorized operating frequency ranges must be lower than the transmitter power (P) by a factor of at least $43 + 10 \log (P)$ dB.	<input checked="" type="checkbox"/>
Test setup			
Procedure	<ul style="list-style-type: none"> <li>- The EUT was connected to Spectrum Analyzer and Base Station via power divider.</li> <li>- The Band Edges of low and high channels for the highest RF powers were measured. Setting RBW as roughly BW/100.</li> </ul>		
Remark			
Result	<input checked="" type="checkbox"/> Pass <input type="checkbox"/> Fail		

Test Data     Yes                       N/A

Test Plot      Yes (See below)             N/A

**GSM Voice:**

**Cellular Band (Part 22H) result**

Frequency (MHz)	Emission (dBm)	Limit (dBm)
823.9975	-17.86	-13
849.0175	-18.9	-13

**PCS Band (Part24E) result**

Frequency (MHz)	Emission (dBm)	Limit (dBm)
1849.9850	-19.88	-13
1910.0200	-17.61	-13

**GPRS:**

**Cellular Band (Part 22H) result**

Frequency (MHz)	Emission (dBm)	Limit (dBm)
824.0000	-15.79	-13
849.0200	-18.27	-13

**PCS Band (Part24E) result**

Frequency (MHz)	Emission (dBm)	Limit (dBm)
1849.9975	-18.3	-13
1910.0020	-17.72	-13

**EGPRS (MCS1):**

**Cellular Band (Part 22H) result**

Frequency (MHz)	Emission (dBm)	Limit (dBm)
823.9975	-16.89	-13
849.0175	-17.54	-13

**PCS Band (Part24E) result**

Frequency (MHz)	Emission (dBm)	Limit (dBm)
1849.9850	-20.23	-13
1910.0250	-17.84	-13

**RMC:**

**UMTS-FDD Band V (Part 22H)**

Frequency (MHz)	Emission (dBm)	Limit (dBm)
823.975	-22.74	-13
849.025	-23.82	-13

**UMTS-FDD Band IV (Part 27)**

Frequency (MHz)	Emission (dBm)	Limit (dBm)
1709.850	-20.28	-13
1755.275	-18.48	-13

**UMTS-FDD Band II (Part 24E)**

Frequency (MHz)	Emission (dBm)	Limit (dBm)
1849.550	-27.12	-13
1910.250	-24.33	-13

**HSUPA:**

**UMTS-FDD Band V (Part 22H)**

Frequency (MHz)	Emission (dBm)	Limit (dBm)
823.950	-22.3	-13
849.125	-25.12	-13

**UMTS-FDD Band IV (Part 27)**

Frequency (MHz)	Emission (dBm)	Limit (dBm)
1709.850	-20.63	-13
1755.300	-19	-13

**UMTS-FDD Band II (Part 24E)**

Frequency (MHz)	Emission (dBm)	Limit (dBm)
1849.850	-25.88	-13
1910.175	-22.39	-13

**HSDPA:**

**UMTS-FDD Band V (Part 22H)**

Frequency (MHz)	Emission (dBm)	Limit (dBm)
823.925	-23.09	-13
849.050	-25.11	-13

**UMTS-FDD Band IV (Part 27)**

Frequency (MHz)	Emission (dBm)	Limit (dBm)
1709.775	-20.98	-13
1755.250	-18.3	-13

**UMTS-FDD Band II (Part 24E)**

Frequency (MHz)	Emission (dBm)	Limit (dBm)
1849.875	-26.74	-13
1910.025	-21.31	-13

### Test Plots

#### GSM Voice:

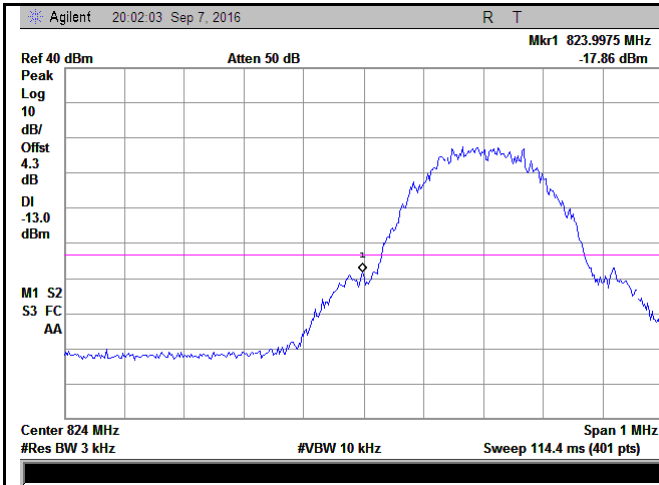

Cellular Band - Low Channel

Note: Offset=Cable loss (4.0) + 10log  
(3.213)=4.0+0.3=4.3dB

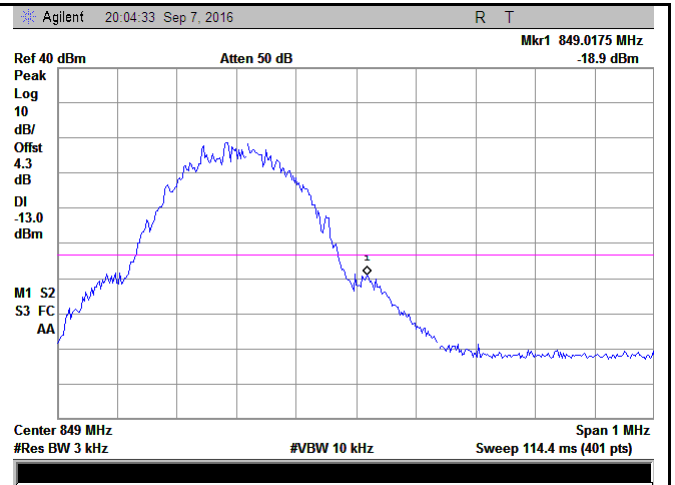

Cellular Band - High Channel

Note: Offset=Cable loss (4.0) + 10log  
(3.20/3)=4.0+0.3=4.3dB

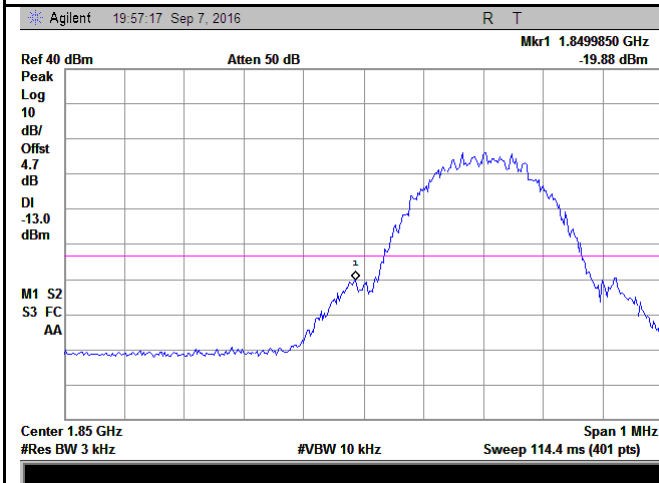

PCS Band - Low Channel

Note: Offset=Cable loss (4.0) + 10log  
(3.23/3)=4.5+0.2=4.7dB

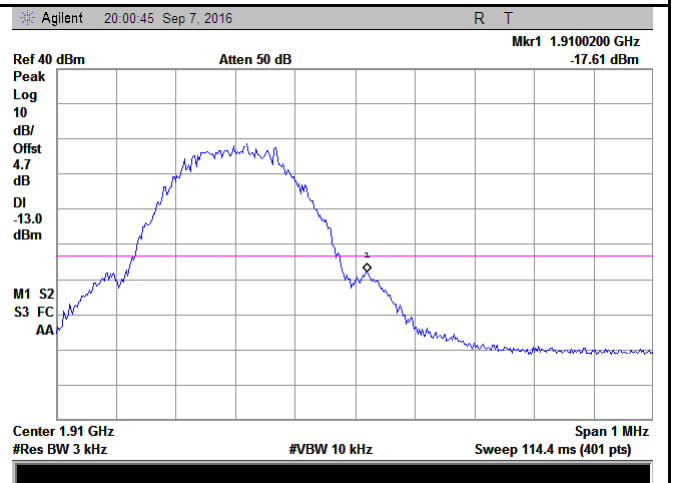

PCS Band - High Channel

Note: Offset=Cable loss (4.0) + 10log  
(3.23/3)=4.5+0.2=4.7dB

**GPRS:**

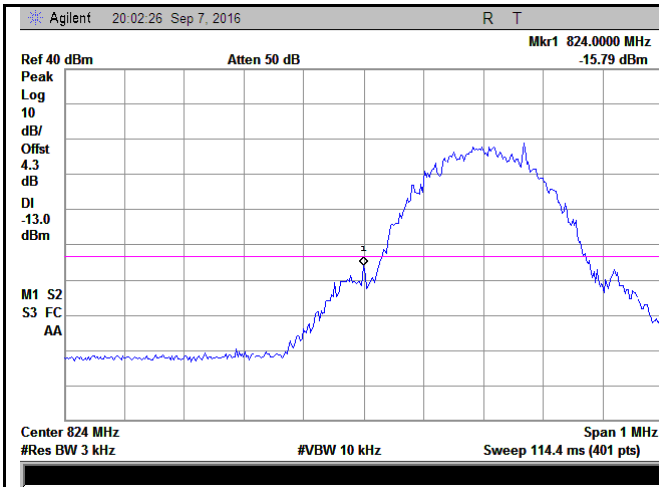

Cellular Band - Low Channel

Note: Offset=Cable loss (4.0) + 10log  
(3.19/3)=4.0+0.3=4.3dB

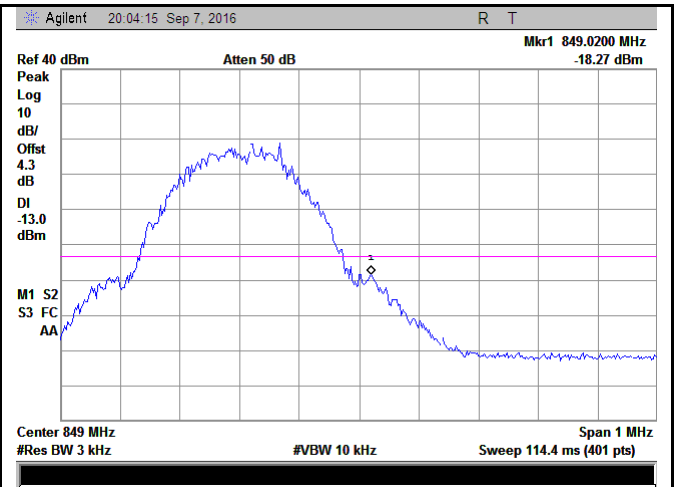

Cellular Band - High Channel

Note: Offset=Cable loss (4.0) + 10log  
(3.20/3)=4.0+0.3=4.3dB

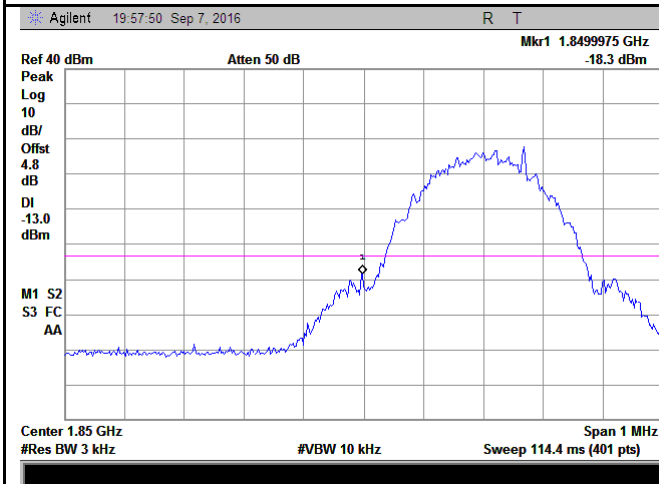

PCS Band - Low Channel

Note: Offset=Cable loss (4.5) + 10log  
(3.20/3)=4.5+0.3=4.8dB

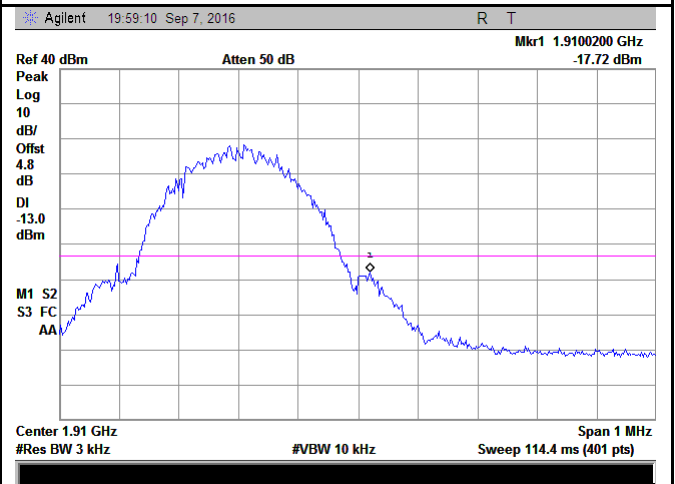

PCS Band - High Channel

Note: Offset=Cable loss (4.5) + 10log  
(3.20/3)=4.5+0.3=4.8dB

**EGPRS (MCS1):**

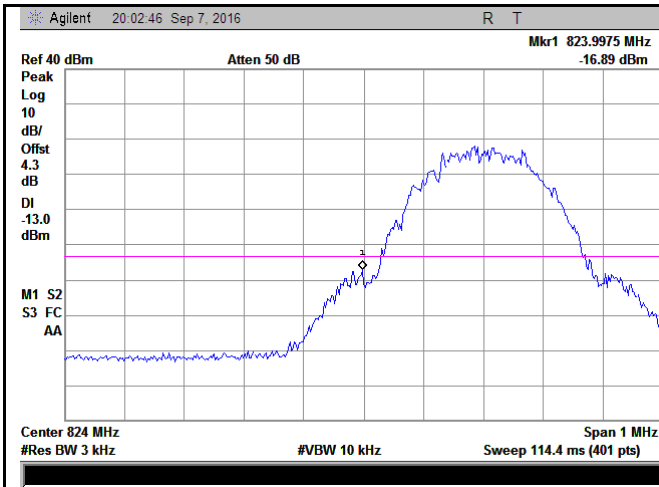

Cellular Band - Low Channel

Note: Offset=Cable loss (4.0) + 10log  
(3.19/3)=4.0+0.3=4.3dB

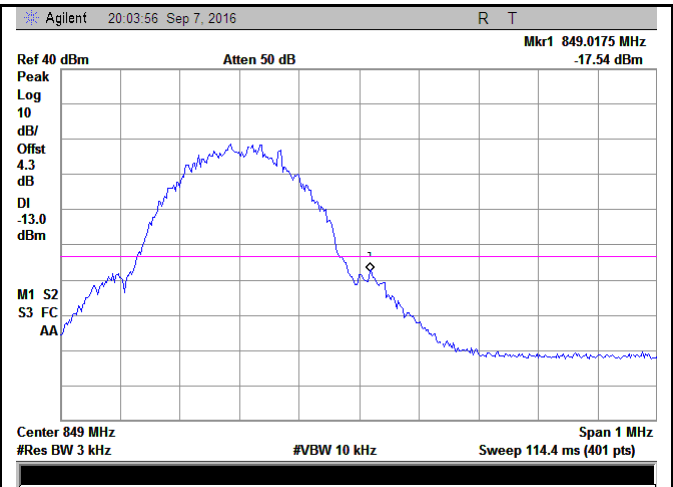

Cellular Band - High Channel

Note: Offset=Cable loss (4.0) + 10log  
(3.18/3)=4.0+0.3=4.3dB

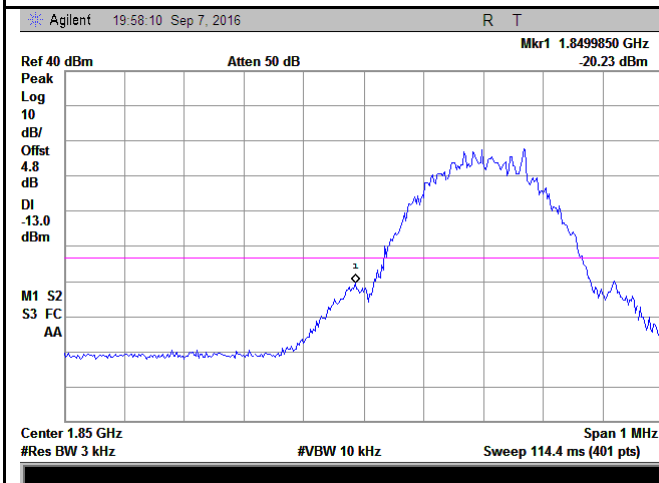

PCS Band - Low Channel

Note: Offset=Cable loss (4.5) + 10log  
(3.15/3)=4.5+0.3=4.8dB

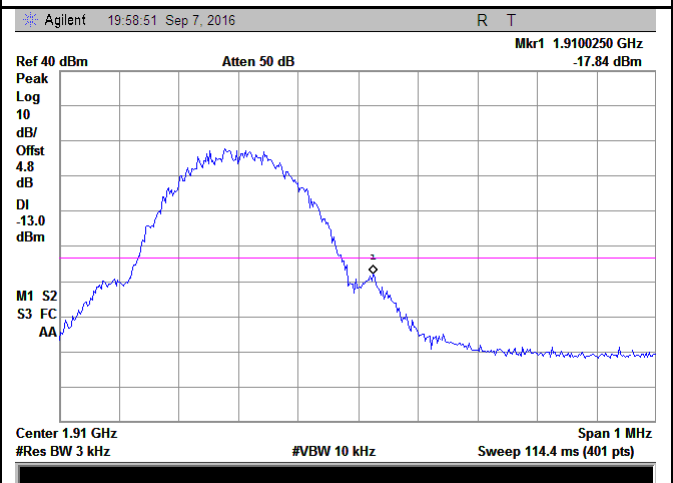

PCS Band - High Channel

Note: Offset=Cable loss (4.5) + 10log  
(3.22/3)=4.5+0.3=4.8dB

**RMC:**

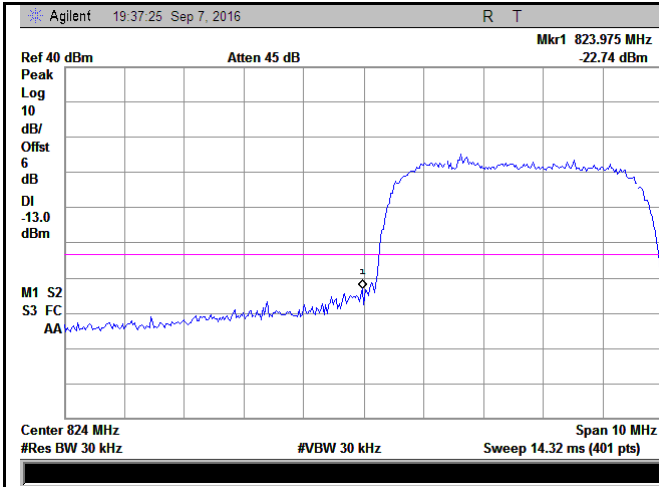

UMTS-FDD Band V - Low Channel

Note: Offset=Cable loss (4.0) + 10log  
(47.02/30)=4.0+2.0=6.0dB

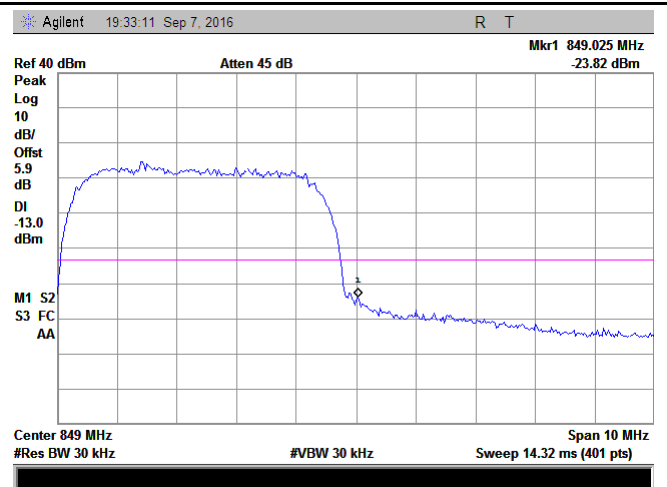

UMTS-FDD Band V - High Channel

Note: Offset=Cable loss (4.0) + 10log  
(47.07/30)=4.0+1.9=5.9dB

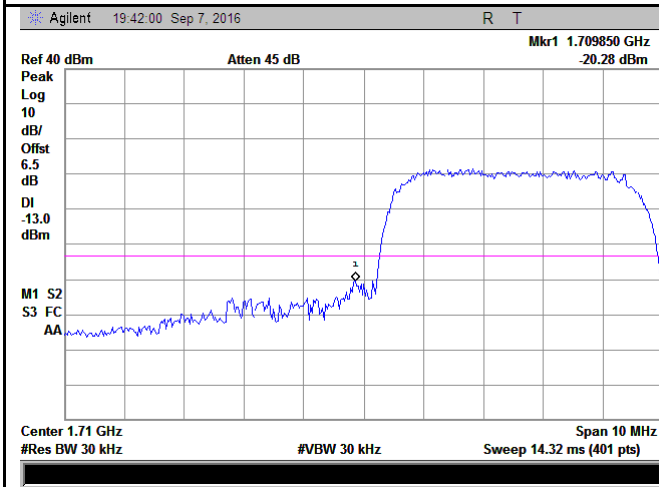

UMTS-FDD Band IV - Low Channel

Note: Offset=Cable loss (4.5) + 10log  
(47.21/30)=4.5+2.0=6.5dB

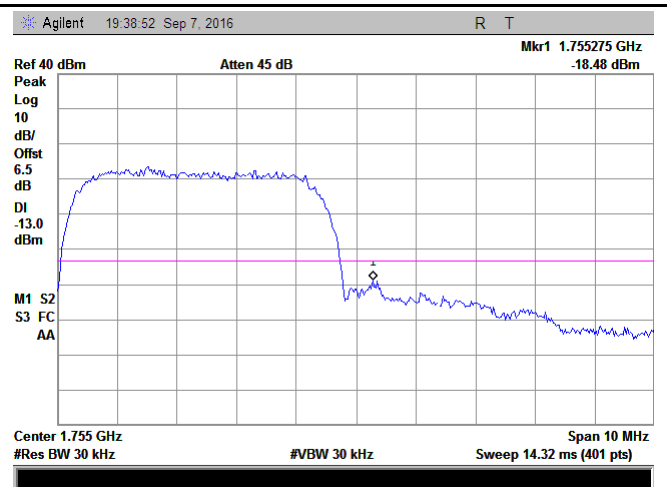

UMTS-FDD Band IV - High Channel

Note: Offset=Cable loss (4.5) + 10log  
(46.99/30)=4.5+2.0=6.5dB

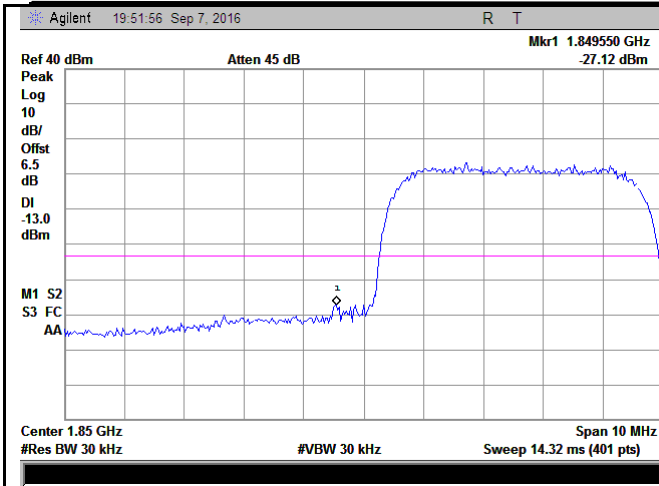

UMTS-FDD Band II - Low Channel

Note: Offset=Cable loss (4.5) + 10log  
 (47.00/30)4.5+2.0=6.5dB

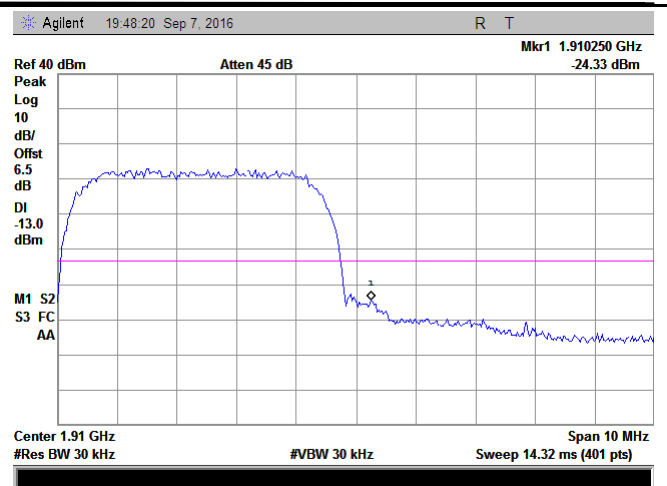

UMTS-FDD Band II - High Channel

Note: Offset=Cable loss (4.5) + 10log  
 (48.05/30)=4.5+2.0=6.5dB

**HSUPA:**

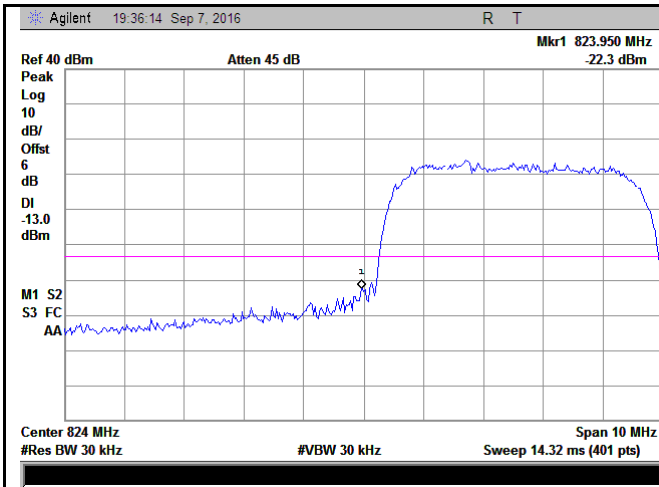

UMTS-FDD Band V - Low Channel

Note: Offset=Cable loss (4.0) + 10log  
(46.99/30)=4.0+2.0=6.0dB

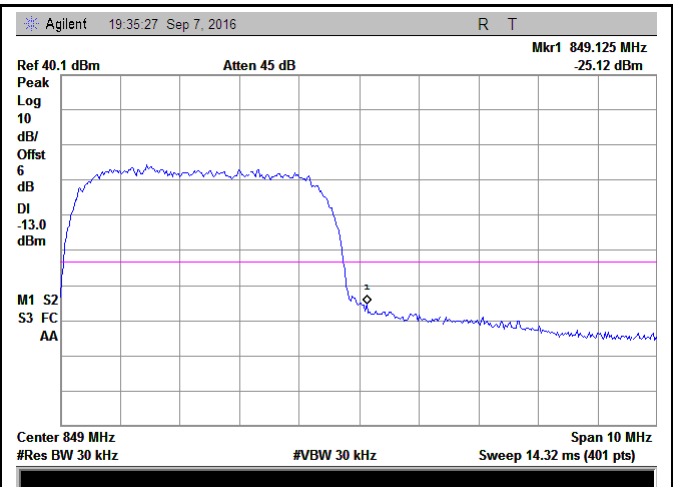

UMTS-FDD Band V - High Channel

Note: Offset=Cable loss (4.0) + 10log  
(47.00/30)=4.0+2.0=6.0dB

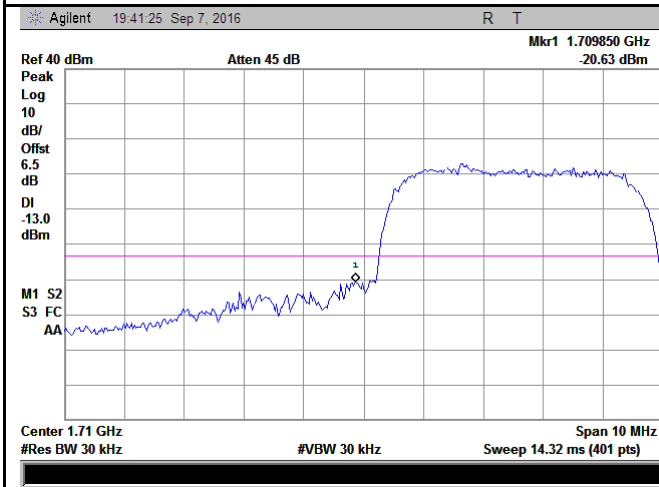

UMTS-FDD Band IV - Low Channel

Note: Offset=Cable loss (4.5) + 10log  
(47.23/30)=4.5+2.0=6.5dB

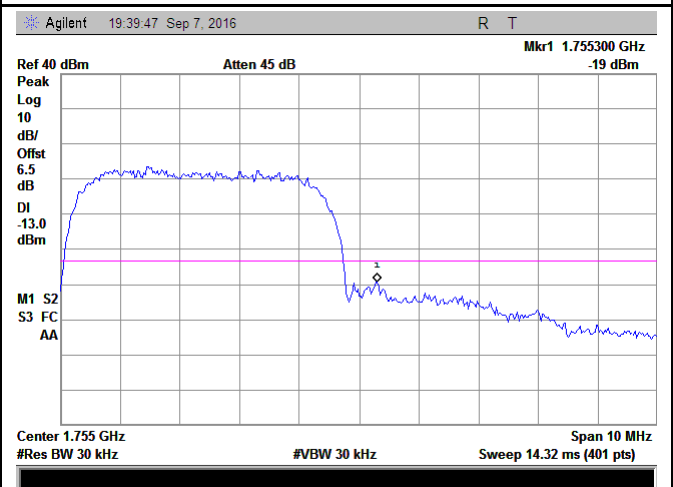

UMTS-FDD Band IV - High Channel

Note: Offset=Cable loss (4.5) + 10log  
(47.05/30)=4.5+2.0=6.5dB

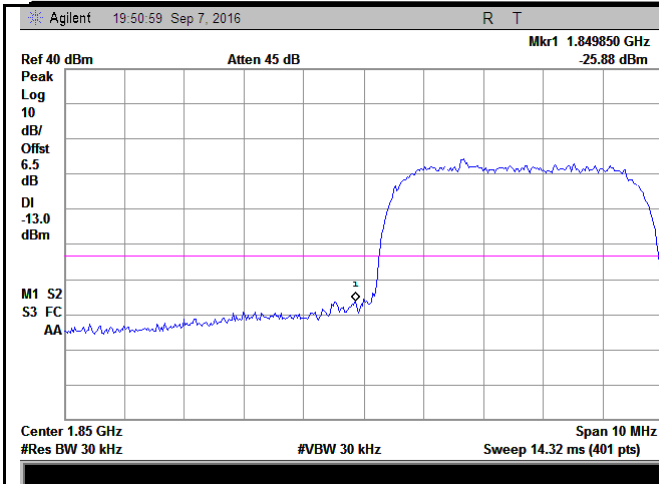

UMTS-FDD Band II - Low Channel

Note: Offset=Cable loss (4.5) + 10log  
 (47.35/30)=4.5+2.0=6.5dB

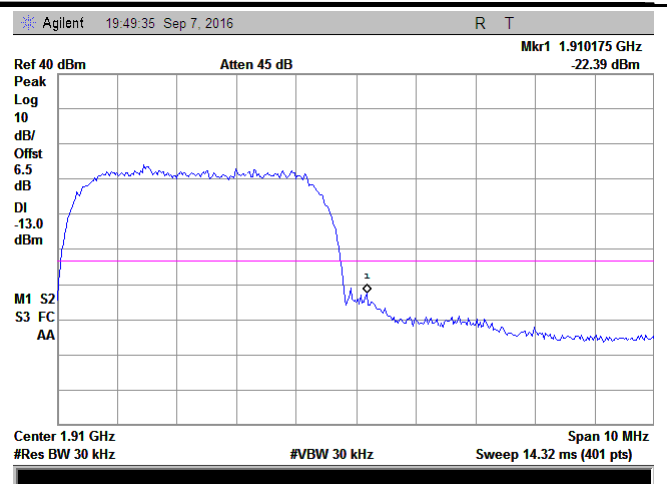

UMTS-FDD Band II - High Channel

Note: Offset=Cable loss (4.5) + 10log  
 (48.40/30)=4.5+2.0=6.5dB

**HSDPA:**

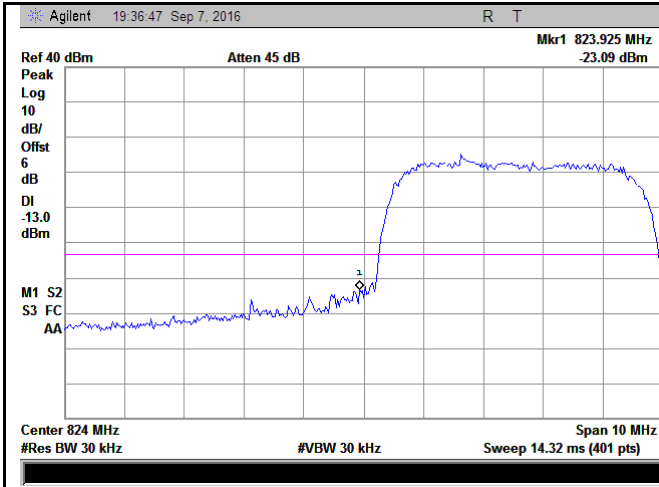

UMTS-FDD Band V - Low Channel

Note: Offset=Cable loss (4.0) + 10log  
(47.08/30)=4.0+2.0=6.0dB

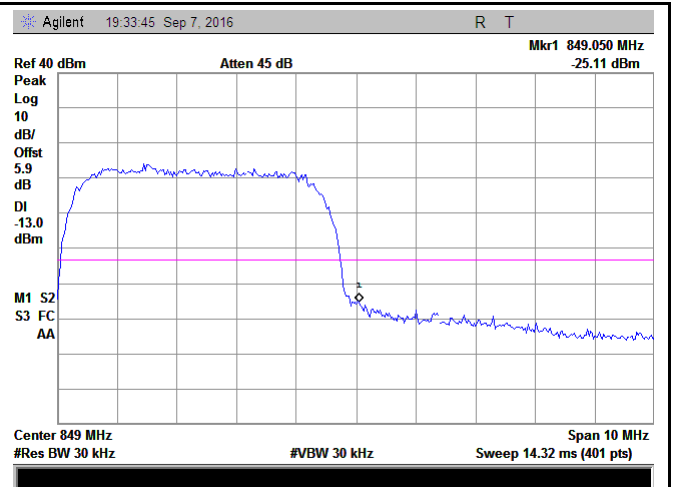

UMTS-FDD Band V - High Channel

Note: Offset=Cable loss (4.0) + 10log  
(46.95/30)=4.0+1.9=5.9dB

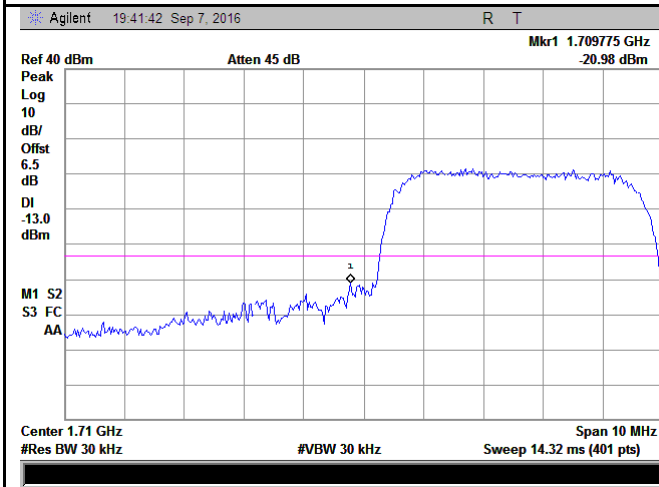

UMTS-FDD Band IV - Low Channel

Note: Offset=Cable loss (4.5) + 10log  
(47.13/30)=4.5+2.0=6.5dB

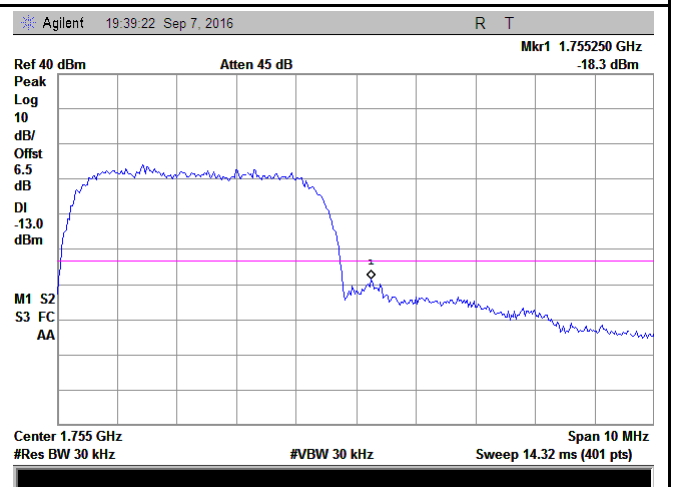

UMTS-FDD Band IV - High Channel

Note: Offset=Cable loss (4.5) + 10log  
(47.10/30)=4.5+2.0=6.5dB

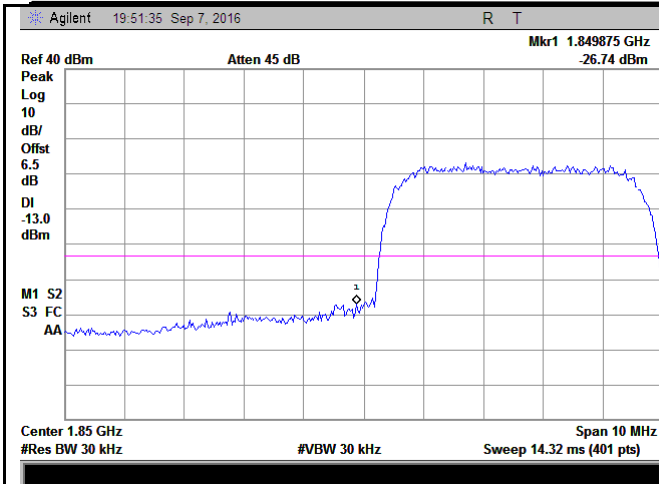

UMTS-FDD Band II - Low Channel

Note: Offset=Cable loss (4.5) + 10log  
 (47.47/30)=4.5+2.0=6.5dB

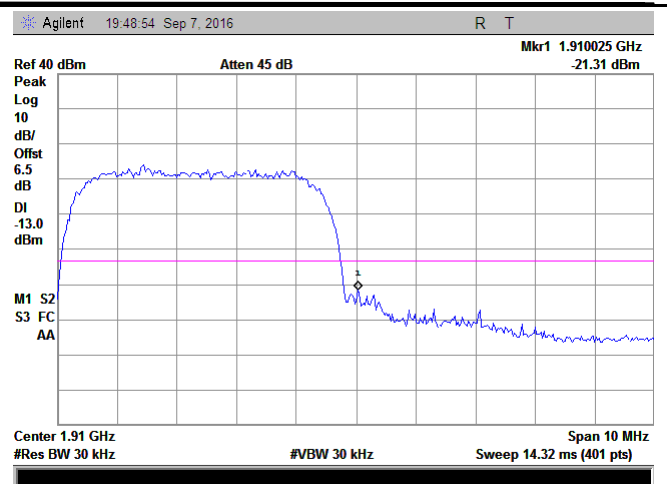

UMTS-FDD Band II - High Channel

Note: Offset=Cable loss (4.5) + 10log  
 (47.63/30)=4.5+2.0=6.5dB

## 6.8 Frequency Stability

Temperature	25°C
Relative Humidity	54%
Atmospheric Pressure	1012mbar
Test date :	September 12, 2016
Tested By :	Loren Luo

### Requirement(s):

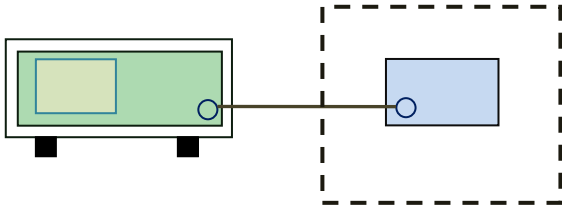
Spec	Item	Requirement	Applicable																																
§2.1055, §22.355 & §24.235 § 27.5(h); § 27.54	a)	According to §22.355, the carrier frequency of each transmitter in the Public Mobile Services must be maintained within the tolerances given in Table below:  Frequency Tolerance for Transmitters in the Public Mobile Services	<input checked="" type="checkbox"/>																																
		<table border="1"> <thead> <tr> <th>Frequency Range (MHz)</th> <th>Base, fixed (ppm)</th> <th>Mobile ≤ 3 watts (ppm)</th> <th>Mobile ≤ 3 watts (ppm)</th> </tr> </thead> <tbody> <tr> <td>25 to 50</td> <td>20.0</td> <td>20.0</td> <td>50.0</td> </tr> <tr> <td>50 to 450</td> <td>5.0</td> <td>5.0</td> <td>50.0</td> </tr> <tr> <td>45 to 512</td> <td>2.5</td> <td>5.0</td> <td>.0</td> </tr> <tr> <td>821 to 896</td> <td>1.5</td> <td>2.5</td> <td>2.5</td> </tr> <tr> <td>928 to 29.</td> <td>5.0</td> <td>N/A</td> <td>N/A</td> </tr> <tr> <td>929 to 960.</td> <td>1.5</td> <td>N/A</td> <td>N/A</td> </tr> <tr> <td>2110 to 2220</td> <td>10.0</td> <td>N/A</td> <td>N/A</td> </tr> </tbody> </table>		Frequency Range (MHz)	Base, fixed (ppm)	Mobile ≤ 3 watts (ppm)	Mobile ≤ 3 watts (ppm)	25 to 50	20.0	20.0	50.0	50 to 450	5.0	5.0	50.0	45 to 512	2.5	5.0	.0	821 to 896	1.5	2.5	2.5	928 to 29.	5.0	N/A	N/A	929 to 960.	1.5	N/A	N/A	2110 to 2220	10.0	N/A	N/A
		Frequency Range (MHz)		Base, fixed (ppm)	Mobile ≤ 3 watts (ppm)	Mobile ≤ 3 watts (ppm)																													
		25 to 50		20.0	20.0	50.0																													
		50 to 450		5.0	5.0	50.0																													
		45 to 512		2.5	5.0	.0																													
		821 to 896		1.5	2.5	2.5																													
		928 to 29.		5.0	N/A	N/A																													
929 to 960.	1.5	N/A	N/A																																
2110 to 2220	10.0	N/A	N/A																																
According to §24.235, the frequency stability shall be sufficient to ensure that the fundamental emissions stay within the authorized frequency block.																																			
																																			
Test setup																																			

Test Report	16071065-FCC-R1
Page	83 of 104

Procedure	A communication link was established between EUT and base station. The frequency error was monitored and measured by base station under variation of ambient temperature and variation of primary supply voltage.  Limit: The frequency stability of the transmitter shall be maintained within $\pm 0.00025\%$ ( $\pm 2.5\text{ppm}$ ) of the center frequency.
Remark	
Result	<input checked="" type="checkbox"/> Pass <input type="checkbox"/> Fail

Test Data     Yes                       N/A

Test Plot     Yes (See below)             N/A

**GSM Voice:**

**Cellular Band (Part 22H) result**

Middle Channel, $f_0 = 836.6$ MHz				
Temperature (°C)	Power Supplied (V <sub>DC</sub> )	Frequency Error (Hz)	Frequency Error (ppm)	Limit (ppm)
-10	3.7	20	0.0239	2.5
0		20	0.0239	2.5
10		18	0.0215	2.5
20		13	0.0155	2.5
30		15	0.0179	2.5
40		20	0.0239	2.5
50		18	0.0215	2.5
55		21	0.0251	2.5
25	4.2	20	0.0239	2.5
	3.5	19	0.0227	2.5

**PCS Band (Part 24E) result**

Middle Channel, $f_0 = 1880$ MHz				
Temperature (°C)	Power Supplied (V <sub>DC</sub> )	Frequency Error (Hz)	Frequency Error (ppm)	Limit (ppm)
-10	3.7	10	0.0053	2.5
0		13	0.0069	2.5
10		10	0.0053	2.5
20		11	0.0059	2.5
30		15	0.0080	2.5
40		16	0.0085	2.5
50		18	0.0096	2.5
55		18	0.0096	2.5
25	4.2	15	0.0080	2.5
	3.5	20	0.0106	2.5

**GPRS:**

**Cellular Band (Part 22H) result**

Middle Channel, $f_0 = 836.6$ MHz				
Temperature (°C)	Power Supplied (V <sub>DC</sub> )	Frequency Error (Hz)	Frequency Error (ppm)	Limit (ppm)
-10	3.7	20	0.0239	2.5
0		17	0.0203	2.5
10		15	0.0179	2.5
20		14	0.0167	2.5
30		10	0.0120	2.5
40		17	0.0203	2.5
50		15	0.0179	2.5
55		21	0.0251	2.5
25	4.2	19	0.0227	2.5
	3.5	16	0.0191	2.5

**PCS Band (Part 24E) result**

Middle Channel, $f_0 = 1880$ MHz				
Temperature (°C)	Power Supplied (V <sub>DC</sub> )	Frequency Error (Hz)	Frequency Error (ppm)	Limit (ppm)
-10	3.7	21	0.0112	2.5
0		18	0.0096	2.5
10		15	0.0080	2.5
20		16	0.0085	2.5
30		11	0.0059	2.5
40		16	0.0085	2.5
50		16	0.0085	2.5
55		13	0.0069	2.5
25	4.2	20	0.0106	2.5
	3.5	19	0.0101	2.5

**EGPRS (MCS1):**

**Cellular Band (Part 22H) result**

Middle Channel, $f_0 = 836.6$ MHz				
Temperature (°C)	Power Supplied (V <sub>DC</sub> )	Frequency Error (Hz)	Frequency Error (ppm)	Limit (ppm)
-10	3.7	21	0.0251	2.5
0		15	0.0179	2.5
10		16	0.0191	2.5
20		11	0.0131	2.5
30		15	0.0179	2.5
40		17	0.0203	2.5
50		15	0.0179	2.5
55		20	0.0239	2.5
25	4.2	11	0.0131	2.5
	3.5	15	0.0179	2.5

**PCS Band (Part 24E) result**

Middle Channel, $f_0 = 1880$ MHz				
Temperature (°C)	Power Supplied (V <sub>DC</sub> )	Frequency Error (Hz)	Frequency Error (ppm)	Limit (ppm)
-10	3.7	21	0.0112	2.5
0		20	0.0106	2.5
10		17	0.0090	2.5
20		11	0.0059	2.5
30		16	0.0085	2.5
40		17	0.0090	2.5
50		12	0.0064	2.5
55		20	0.0106	2.5
25	4.2	20	0.0106	2.5
	3.5	16	0.0085	2.5

RMC:

UMTS-FDD Band V (Part 22H)

Middle Channel, $f_0 = 835$ MHz				
Temperature (°C)	Power Supplied (V <sub>DC</sub> )	Frequency Error (Hz)	Frequency Error (ppm)	Limit (ppm)
-10	3.7	15	0.0180	2.5
0		10	0.0120	2.5
10		10	0.0120	2.5
20		14	0.0168	2.5
30		15	0.0180	2.5
40		13	0.0156	2.5
50		15	0.0180	2.5
55		17	0.0204	2.5
25	4.2	11	0.0132	2.5
	3.5	21	0.0251	2.5

UMTS-FDD Band II (Part 24E)

Middle Channel, $f_0 = 1880$ MHz				
Temperature (°C)	Power Supplied (V <sub>DC</sub> )	Frequency Error (Hz)	Frequency Error (ppm)	Limit (ppm)
-10	3.7	20	0.0106	2.5
0		11	0.0059	2.5
10		10	0.0053	2.5
20		9	0.0048	2.5
30		13	0.0069	2.5
40		15	0.0080	2.5
50		14	0.0074	2.5
55		12	0.0064	2.5
25	4.2	14	0.0074	2.5
	3.5	16	0.0085	2.5

**UMTS-FDD Band IV (Part 27E)**

Middle Channel, $f_0 = 1732.6$ MHz				
Temperature (°C)	Power Supplied (V <sub>DC</sub> )	Frequency Error (Hz)	Frequency Error (ppm)	Limit (ppm)
-10	3.7	17	0.0204	2.5
0		16	0.0192	2.5
10		15	0.0180	2.5
20		16	0.0192	2.5
30		17	0.0204	2.5
40		11	0.0132	2.5
50		14	0.0168	2.5
55		15	0.0180	2.5
25		4.2	9	0.0108
	3.5	15	0.0180	2.5

**HSUPA:**

**UMTS-FDD Band V (Part 22H)**

Middle Channel, $f_0 = 835$ MHz				
Temperature (°C)	Power Supplied (V <sub>DC</sub> )	Frequency Error (Hz)	Frequency Error (ppm)	Limit (ppm)
-10	3.7	19	0.0228	2.5
0		15	0.0180	2.5
10		11	0.0132	2.5
20		16	0.0192	2.5
30		12	0.0144	2.5
40		11	0.0132	2.5
50		21	0.0251	2.5
55		19	0.0228	2.5
25	4.2	18	0.0216	2.5
	3.5	20	0.0240	2.5

**UMTS-FDD Band II (Part 24E)**

Middle Channel, $f_0 = 1880$ MHz				
Temperature (°C)	Power Supplied (V <sub>DC</sub> )	Frequency Error (Hz)	Frequency Error (ppm)	Limit (ppm)
-10	3.7	18	0.0096	2.5
0		16	0.0085	2.5
10		14	0.0074	2.5
20		12	0.0064	2.5
30		14	0.0074	2.5
40		15	0.0080	2.5
50		16	0.0085	2.5
55		21	0.0112	2.5
25		4.2	17	0.0090
	3.5	20	0.0106	2.5

**UMTS-FDD Band IV (Part 27E)**

Middle Channel, $f_0 = 1732.6$ MHz				
Temperature (°C)	Power Supplied (V <sub>DC</sub> )	Frequency Error (Hz)	Frequency Error (ppm)	Limit (ppm)
-10	3.7	13	0.0156	2.5
0		14	0.0168	2.5
10		12	0.0144	2.5
20		11	0.0132	2.5
30		10	0.0120	2.5
40		9	0.0108	2.5
50		11	0.0132	2.5
55		15	0.0180	2.5
25	4.2	21	0.0251	2.5
	3.5	19	0.0228	2.5

**HSDPA:**

**UMTS-FDD Band V (Part 22H)**

Middle Channel, $f_0 = 835$ MHz				
Temperature (°C)	Power Supplied (V <sub>DC</sub> )	Frequency Error (Hz)	Frequency Error (ppm)	Limit (ppm)
-10	3.7	20	0.0240	2.5
0		16	0.0192	2.5
10		12	0.0144	2.5
20		11	0.0132	2.5
30		13	0.0156	2.5
40		14	0.0168	2.5
50		16	0.0192	2.5
55		19	0.0228	2.5
25	4.2	20	0.0240	2.5
	3.5	15	0.0180	2.5

**UMTS-FDD Band II (Part 24E)**

Middle Channel, $f_0 = 1880$ MHz				
Temperature (°C)	Power Supplied (V <sub>DC</sub> )	Frequency Error (Hz)	Frequency Error (ppm)	Limit (ppm)
-10	3.7	21	0.0112	2.5
0		20	0.0106	2.5
10		15	0.0080	2.5
20		11	0.0059	2.5
30		10	0.0053	2.5
40		15	0.0080	2.5
50		16	0.0085	2.5
55		17	0.0090	2.5
25	4.2	14	0.0074	2.5
	3.5	14	0.0074	2.5

**UMTS-FDD Band IV (Part 27E)**

Middle Channel, $f_0 = 1732.6$ MHz				
Temperature (°C)	Power Supplied (V <sub>DC</sub> )	Frequency Error (Hz)	Frequency Error (ppm)	Limit (ppm)
-10	3.7	21	0.0251	2.5
0		15	0.0180	2.5
10		16	0.0192	2.5
20		14	0.0168	2.5
30		12	0.0144	2.5
40		16	0.0192	2.5
50		15	0.0180	2.5
55		20	0.0240	2.5
25	4.2	19	0.0228	2.5
	3.5	16	0.0192	2.5

## Annex A. TEST INSTRUMENT

Instrument	Model	Serial #	Cal Date	Cal Due	In use
<b>RF Conducted Test</b>					
Agilent ESA-E SERIES SPECTRUM ANALYZER	E4407B	MY45108319	09/16/2015	09/15/2016	<input checked="" type="checkbox"/>
Power Splitter	1#	1#	08/31/2016	09/30/2017	<input checked="" type="checkbox"/>
Universal Radio Communication Tester	CMU200	121393	09/25/2015	09/24/2016	<input checked="" type="checkbox"/>
Temperature/Humidity Chamber	UHL-270	001	10/09/2015	10/08/2016	<input checked="" type="checkbox"/>
DC Power Supply	E3640A	MY40004013	09/17/2015	09/16/2016	<input checked="" type="checkbox"/>
RF Power Sensor	Dare RPR3006C/P/W	AY554013	09/17/2015	09/16/2016	<input checked="" type="checkbox"/>
<b>Radiated Emissions</b>					
EMI test receiver	ESL6	100262	09/17/2015	09/16/2016	<input checked="" type="checkbox"/>
OPT 010 AMPLIFIER (0.1-1300MHz)	8447E	2727A02430	08/31/2016	08/30/2017	<input checked="" type="checkbox"/>
Microwave Preamplifier (1 ~ 26.5GHz)	8449B	3008A02402	03/24/2016	03/23/2017	<input checked="" type="checkbox"/>
Bilog Antenna (30MHz~6GHz)	JB6	A110712	09/21/2015	09/20/2016	<input checked="" type="checkbox"/>
Bilog Antenna (30MHz~2GHz)	JB1	A112017	09/21/2015	09/20/2016	<input checked="" type="checkbox"/>
Double Ridge Horn Antenna (1 ~18GHz)	AH-118	71259	09/24/2015	09/23/2016	<input checked="" type="checkbox"/>
Double Ridge Horn Antenna (1 ~18GHz)	AH-118	71283	09/24/2015	09/23/2016	<input checked="" type="checkbox"/>
SYNTHESIZED SIGNAL GENERATOR	8665B	3744A01293	09/17/2015	09/16/2016	<input checked="" type="checkbox"/>
Power Amplifier	SMC150D	R1553-0313	03/09/2016	03/08/2017	<input checked="" type="checkbox"/>
Power Amplifier	S41-25D	R1553-0314	05/27/2016	05/26/2017	<input checked="" type="checkbox"/>
Tunable Notch Filter	3NF-800/1000-S	AA4	08/31/2016	08/30/2017	<input checked="" type="checkbox"/>

Test Report	16071065-FCC-R1
Page	94 of 104

Tunable Notch Filter	3NF- 1000/2000-S	AM 4	08/31/2016	08/30/2017	<input checked="" type="checkbox"/>
----------------------	---------------------	------	------------	------------	-------------------------------------

**Annex B. EUT And Test Setup Photographs**

**Annex B.i. Photograph: EUT External Photo**

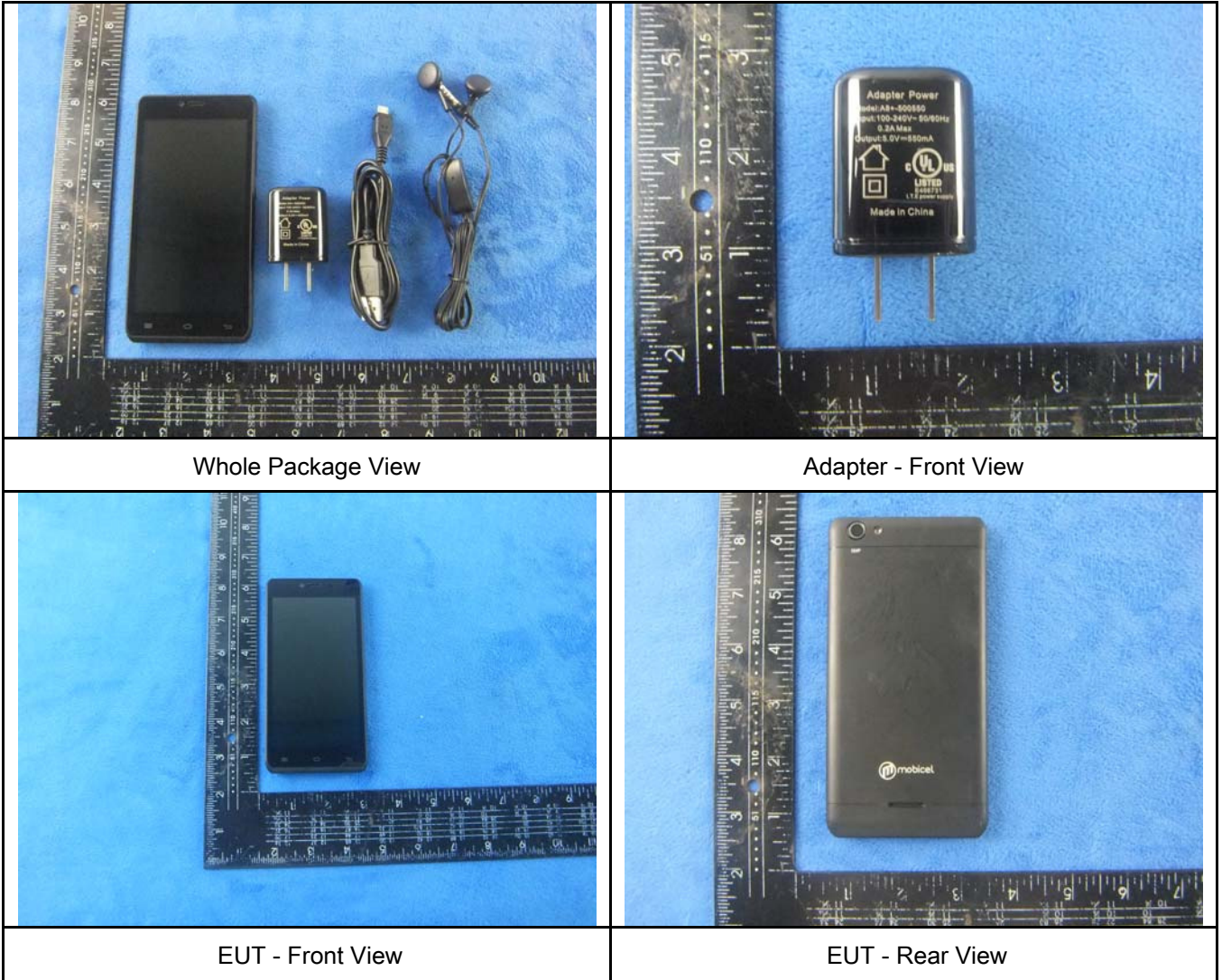

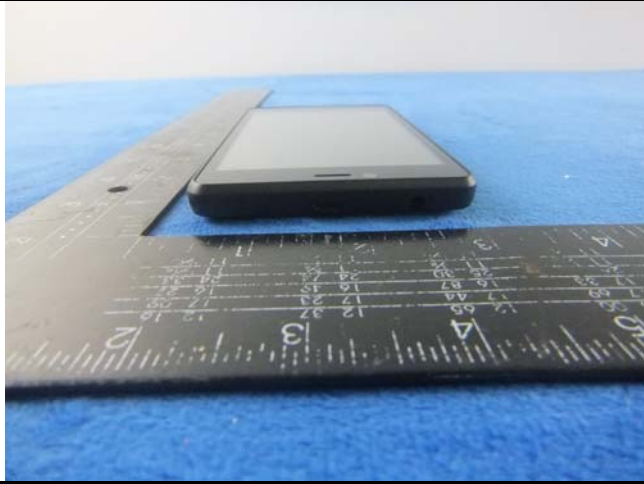

EUT - Top View

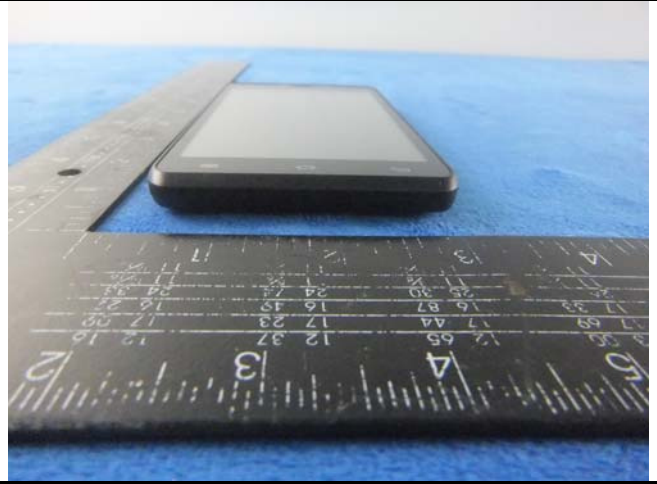

EUT - Bottom View

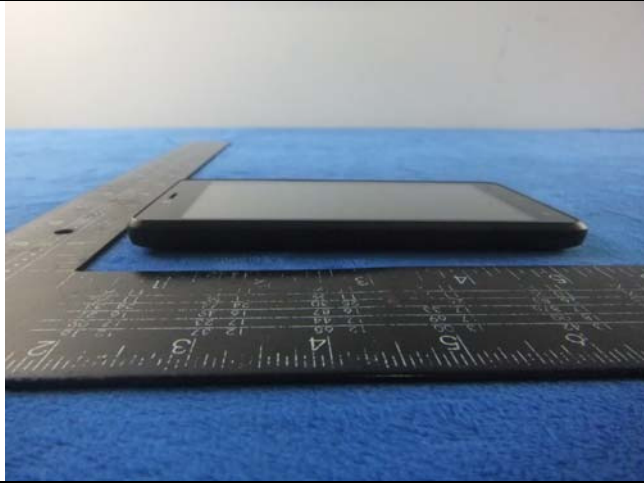

EUT - Left View

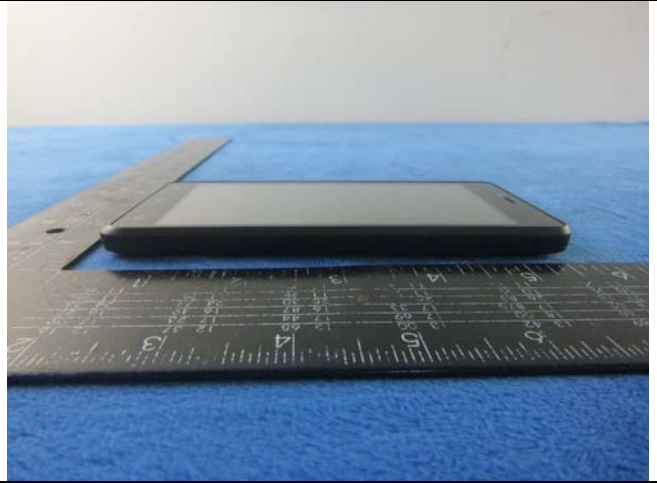

EUT - Right View

**Annex B.ii. Photograph: EUT Internal Photo**



Cover Off - Top View 1



Cover Off - Top View 2



Battery - Front View



Battery - Rear View



Mainboard with Shielding - Front View



Mainboard without Shielding - Front View

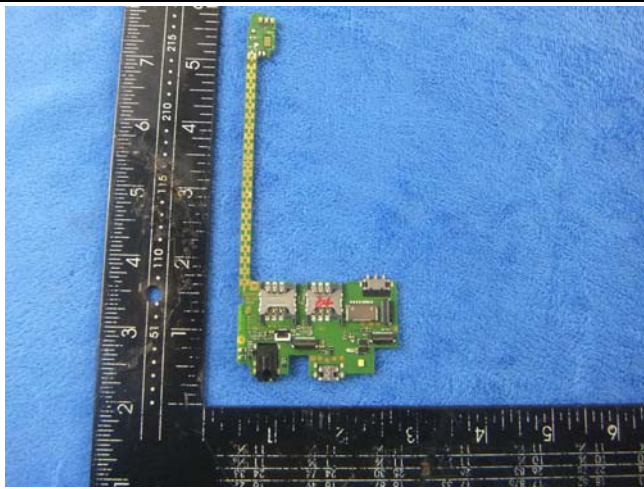

Mainboard - Rear View



LCD - Front View



LCD - Rear View



GSM/PCS/UMTS-FDD Antenna View



WIFI/BT/BLE/GPS - Antenna View

**Annex B.iii. Photograph: Test Setup Photo**

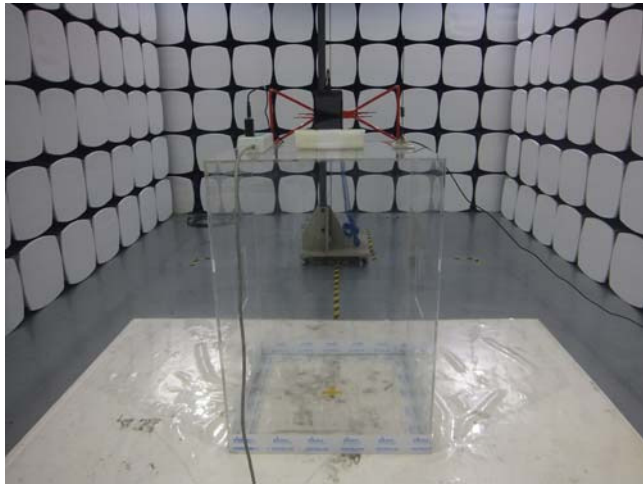

Radiated Spurious Emissions Test Setup Below 1GHz

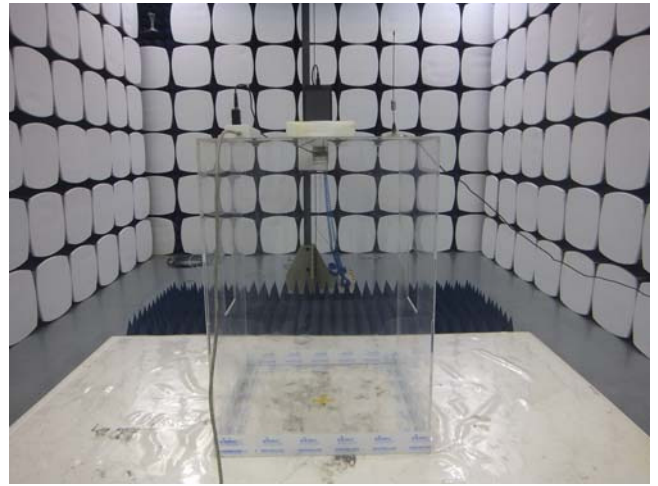

Radiated Spurious Emissions Test Setup Above  
1GHz

## Annex C. TEST SETUP AND SUPPORTING EQUIPMENT

### Annex C.ii. TEST SET UP BLOCK

#### Block Configuration Diagram for Radiated Emissions

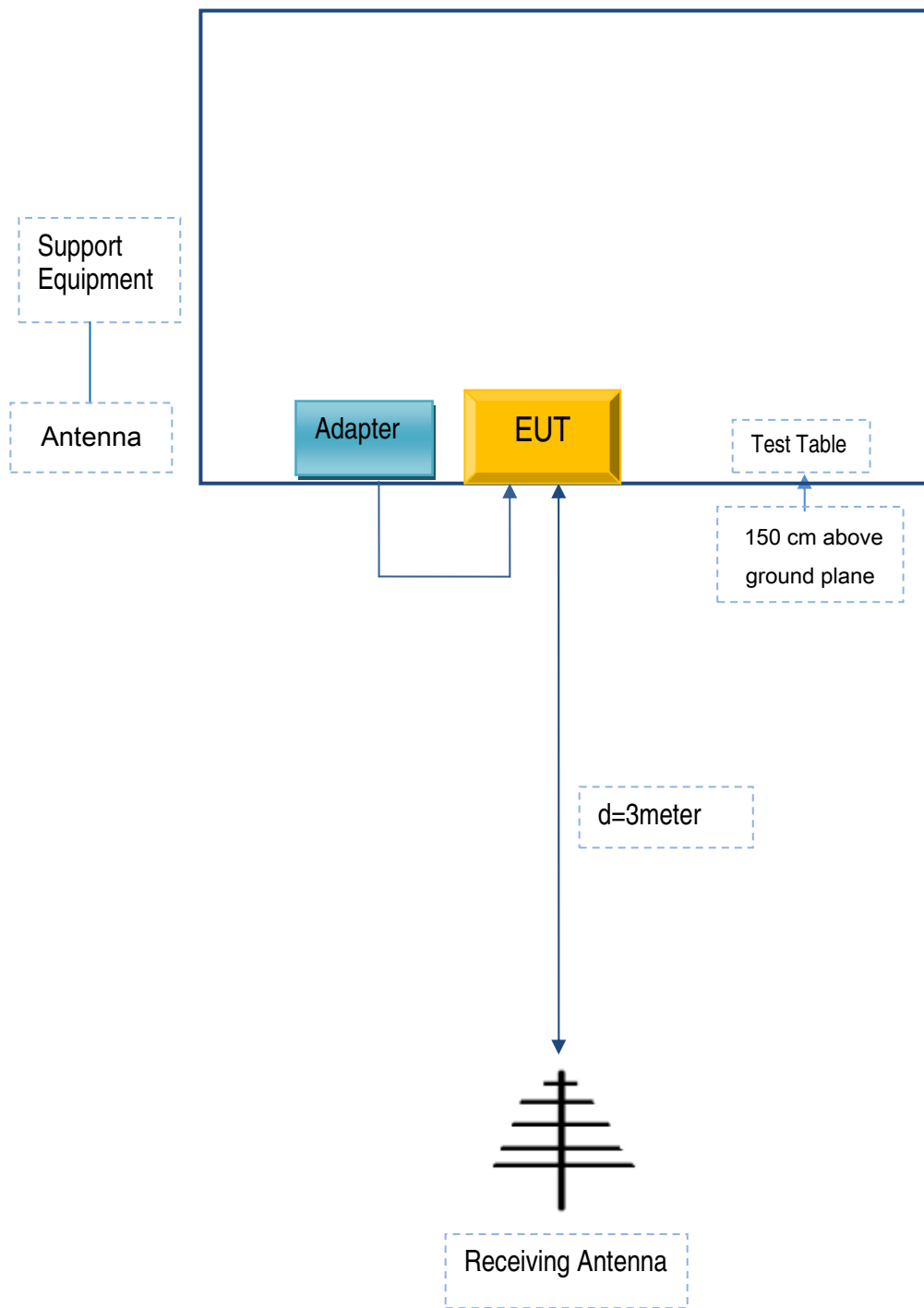

## Annex C. ii. SUPPORTING EQUIPMENT DESCRIPTION

The following is a description of supporting equipment and details of cables used with the EUT.

### Supporting Equipment:

Manufacturer	Equipment Description	Model	Serial No
MOBIWIRE MOBILES (NINGBO) CO.,LTD.	Adapter	A8+-500550	CL0002

### Supporting Cable:

Cable type	Shield Type	Ferrite Core	Length	Serial No
USB Cable	Un-shielding	No	0.8m	CL0002

Test Report	16071065-FCC-R1
Page	102 of 104

## Annex C.ii. EUT OPERATING CONKITIONS

N/A

Test Report	16071065-FCC-R1
Page	103 of 104

**Annex D. User Manual / Block Diagram / Schematics / Partlist**

**See attachment**

Test Report	16071065-FCC-R1
Page	104 of 104

## Annex E. DECLARATION OF SIMILARITY

N/A