

**APPLICATION CERTIFICATION**

On Behalf of

Shenzhen Jiayinking Technology Holding Company Limited

Suitcase Bluetooth Turntable

Model No.: CS-14001, CS-14004-1, ITVS-550BT, CS-14002, 14ST080, 14ST081

FCC ID: 2ADA2-CS-14001

Prepared for : Shenzhen Jiayinking Technology Holding Company Limited  
Address : No.11, 11-1 Anye Road, Anliang Village, Henggang Town, Longgang District, Shenzhen City, Guangdong Province, China  
Prepared by : ACCURATE TECHNOLOGY CO. LTD  
Address : F1, Bldg. A, Changyuan New Material Port, Keyuan Rd. Science & Industry Park, Nanshan, Shenzhen, Guangdong P.R. China

Tel: (0755) 26503290  
Fax: (0755) 26503396

Report Number : ATE20141861  
Date of Test : Sep 25, 2014- Sep 28, 2014  
Date of Report : Sep 28, 2014

## TABLE OF CONTENTS

Description	Page
Test Report Certification	
<b>1. GENERAL INFORMATION .....</b>	<b>5</b>
1.1. Product of Device (EUT) .....	5
1.2. Accessory and Auxiliary Equipment.....	5
1.3. Description of Test Facility .....	6
1.4. Measurement Uncertainty.....	6
<b>2. MEASURING DEVICE AND TEST EQUIPMENT .....</b>	<b>7</b>
<b>3. OPERATION OF EUT DURING TESTING .....</b>	<b>8</b>
3.1. Operating Mode .....	8
3.2. Configuration and peripherals .....	8
<b>4. TEST PROCEDURES AND RESULTS .....</b>	<b>9</b>
<b>5. 20DB BANDWIDTH TEST.....</b>	<b>10</b>
5.1. Block Diagram of Test Setup.....	10
5.2. The Requirement For Section 15.247(a)(1).....	10
5.3. EUT Configuration on Measurement .....	10
5.4. Operating Condition of EUT .....	10
5.5. Test Procedure .....	10
5.6. Test Result .....	11
<b>6. CARRIER FREQUENCY SEPARATION TEST.....</b>	<b>17</b>
6.1. Block Diagram of Test Setup.....	17
6.2. The Requirement For Section 15.247(a)(1).....	17
6.3. EUT Configuration on Measurement .....	17
6.4. Operating Condition of EUT .....	17
6.5. Test Procedure .....	18
6.6. Test Result .....	18
<b>7. NUMBER OF HOPPING FREQUENCY TEST .....</b>	<b>24</b>
7.1. Block Diagram of Test Setup.....	24
7.2. The Requirement For Section 15.247(a)(1)(iii) .....	24
7.3. EUT Configuration on Measurement .....	24
7.4. Operating Condition of EUT .....	24
7.5. Test Procedure .....	24
7.6. Test Result .....	25
<b>8. DWELL TIME TEST .....</b>	<b>27</b>
8.1. Block Diagram of Test Setup.....	27
8.2. The Requirement For Section 15.247(a)(1)(iii).....	27
8.3. EUT Configuration on Measurement .....	27
8.4. Operating Condition of EUT .....	27
8.5. Test Procedure .....	27
8.6. Test Result .....	28
<b>9. MAXIMUM PEAK OUTPUT POWER TEST .....</b>	<b>43</b>
9.1. Block Diagram of Test Setup.....	43
9.2. The Requirement For Section 15.247(b)(1).....	43
9.3. EUT Configuration on Measurement .....	43
9.4. Operating Condition of EUT .....	43
9.5. Test Procedure .....	43

9.6.	Test Result .....	44
<b>10.</b>	<b>RADIATED EMISSION TEST .....</b>	<b>50</b>
10.1.	Block Diagram of Test Setup.....	50
10.2.	The Limit For Section 15.247(d) .....	51
10.3.	Restricted bands of operation .....	51
10.4.	Configuration of EUT on Measurement .....	52
10.5.	Test Procedure .....	52
10.6.	The Field Strength of Radiation Emission Measurement Results .....	52
<b>11.</b>	<b>BAND EDGE COMPLIANCE TEST .....</b>	<b>65</b>
11.1.	Block Diagram of Test Setup.....	65
11.2.	The Requirement For Section 15.247(d) .....	65
11.3.	EUT Configuration on Measurement .....	65
11.4.	Operating Condition of EUT .....	65
11.5.	Test Procedure .....	66
11.6.	Test Result .....	66
<b>12.</b>	<b>AC POWER LINE CONDUCTED EMISSION FOR FCC PART 15 SECTION 15.207(A) ..</b>	<b>89</b>
12.1.	Block Diagram of Test Setup.....	89
12.2.	The Emission Limit .....	89
12.3.	Configuration of EUT on Measurement .....	90
12.4.	Operating Condition of EUT .....	90
12.5.	Test Procedure .....	90
12.6.	Power Line Conducted Emission Measurement Results .....	90
<b>13.</b>	<b>ANTENNA REQUIREMENT.....</b>	<b>94</b>
13.1.	The Requirement .....	94
13.2.	Antenna Construction .....	94

## Test Report Certification

Applicant : Shenzhen Jiayinking Technology Holding Company Limited

Manufacturer : Shenzhen Jiayinking Technology Holding Company Limited

EUT Description : Suitcase Bluetooth Turntable

(A) MODEL NO.: CS-14001, CS-14004-1, ITVS-550BT, CS-14002,  
14ST080, 14ST081

(B) Trade Name.: /

(C) POWER SUPPLY: AC 120V/60Hz (Powered by adapter)

Measurement Procedure Used:

FCC Rules and Regulations Part 15 Subpart C Section 15.247  
ANSI C63.4- 2009

The device described above is tested by ACCURATE TECHNOLOGY CO. LTD to determine the maximum emission levels emanating from the device. The maximum emission levels are compared to the FCC Part 15 Subpart C Section 15.247 limits. The measurement results are contained in this test report and ACCURATE TECHNOLOGY CO. LTD is assumed full responsibility for the accuracy and completeness of these measurements. Also, this report shows that the Equipment Under Test (EUT) is to be technically compliant with the FCC requirements.

This report applies to above tested sample only. This report shall not be reproduced in part without written approval of ACCURATE TECHNOLOGY CO. LTD.

Date of Test : Sep 25, 2014-Sep 28, 2014

Prepared by :

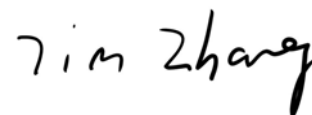

(Tim.zhang, Engineer)

Approved & Authorized Signer :



( Sean Liu, Manager)

## 1. GENERAL INFORMATION

### 1.1.Product of Device (EUT)

Product	:	Suitcase Bluetooth Turntable
Model No.	:	CS-14001, CS-14004-1, ITVS-550BT, CS-14002, 14ST080, 14ST081
Frequency Band	:	2402MHz-2480MHz
Number of Channels	:	79
Modulation type	:	GFSK, $\Pi/4$ -DQPSK, 8DPSK
Antenna Gain	:	0dBi
Antenna type	:	PCB Antenna
Applicant	:	Shenzhen Jiayinking Technology Holding Company Limited
Address	:	No.11, 11-1 Anye Road, Anliang Village, Henggang Town, Longgang District, Shenzhen City, Guangdong Province, China
Manufacturer	:	Shenzhen Jiayinking Technology Holding Company Limited
Address	:	No.11, 11-1 Anye Road, Anliang Village, Henggang Town, Longgang District, Shenzhen City, Guangdong Province, China
Power Supply Adapter	:	AC 120V/60Hz (Powered by Adapter) Model:TEKA006-0501000UK Input: AC 100-240V 50/60Hz 0.2A Output: 5.0V 1A
Date of sample received	:	Sep 25, 2014
Date of Test	:	Sep 25, 2014-Sep 28, 2014

### 1.2.Accessory and Auxiliary Equipment

N/A

### 1.3. Description of Test Facility

EMC Lab : Accredited by TUV Rheinland Shenzhen

Listed by FCC

The Registration Number is 752051

Listed by Industry Canada

The Registration Number is 5077A-2

Accredited by China National Accreditation Committee  
for Laboratories

The Certificate Registration Number is L3193

Name of Firm : ACCURATE TECHNOLOGY CO. LTD

Site Location : F1, Bldg. A, Changyuan New Material Port, Keyuan Rd.  
Science & Industry Park, Nanshan, Shenzhen, Guangdong  
P.R. China

### 1.4. Measurement Uncertainty

Conducted Emission Expanded Uncertainty = 2.23dB, k=2

Radiated emission expanded uncertainty = 3.08dB, k=2  
(9kHz-30MHz)

Radiated emission expanded uncertainty = 4.42dB, k=2  
(30MHz-1000MHz)

Radiated emission expanded uncertainty = 4.06dB, k=2  
(Above 1GHz)

## 2. MEASURING DEVICE AND TEST EQUIPMENT

**Table 1: List of Test and Measurement Equipment**

Kind of equipment	Manufacturer	Type	S/N	Calibrated dates	Calibrated until
EMI Test Receiver	Rohde&Schwarz	ESCS30	100307	Jan. 11, 2014	Jan. 10, 2015
EMI Test Receiver	Rohde&Schwarz	ESPI3	101526/003	Jan. 11, 2014	Jan. 10, 2015
Spectrum Analyzer	Agilent	E7405A	MY45115511	Jan. 11, 2014	Jan. 10, 2015
Pre-Amplifier	Rohde&Schwarz	CBLU118354 0-01	3791	Jan. 11, 2014	Jan. 10, 2015
Loop Antenna	Schwarzbeck	FMZB1516	1516131	Jan. 15, 2014	Jan. 14, 2015
Bilog Antenna	Schwarzbeck	VULB9163	9163-323	Jan. 15, 2014	Jan. 14, 2015
Horn Antenna	Schwarzbeck	BBHA9120D	9120D-655	Jan. 15, 2014	Jan. 14, 2015
Horn Antenna	Schwarzbeck	BBHA9120D	9120D-1067	Jan. 15, 2014	Jan. 14, 2015
LISN	Rohde&Schwarz	ESH3-Z5	100305	Jan. 11, 2014	Jan. 10, 2015
LISN	Schwarzbeck	NSLK8126	8126431	Jan. 11, 2014	Jan. 10, 2015
Highpass Filter	Wainwright Instruments	WHKX3.6/18 G-10SS	N/A	Jan. 11, 2014	Jan. 10, 2015
Band Reject Filter	Wainwright Instruments	WRCG2400/2 485-2375/2510 -60/11SS	N/A	Jan. 11, 2014	Jan. 10, 2015

### 3. OPERATION OF EUT DURING TESTING

#### 3.1. Operating Mode

The mode is used: Transmitting mode

Low Channel: 2402MHz

Middle Channel: 2441MHz

High Channel: 2480MHz

Hopping

#### 3.2. Configuration and peripherals



(EUT: Suitcase Bluetooth Turntable)



#### 4. TEST PROCEDURES AND RESULTS

<b>FCC Rules</b>	<b>Description of Test</b>	<b>Result</b>
Section 15.207	Conducted Emission Test	Compliant
Section 15.247(a)(1)	20dB Bandwidth Test	Compliant
Section 15.247(a)(1)	Carrier Frequency Separation Test	Compliant
Section 15.247(a)(1)(iii)	Number Of Hopping Frequency Test	Compliant
Section 15.247(a)(1)(iii)	Dwell Time Test	Compliant
Section 15.247(b)(1)	Maximum Peak Output Power Test	Compliant
Section 15.247(d) Section 15.209	Radiated Emission Test	Compliant
Section 15.247(d)	Band Edge Compliance Test	Compliant
Section 15.203	Antenna Requirement	Compliant

## 5. 20DB BANDWIDTH TEST

### 5.1. Block Diagram of Test Setup



(EUT: Suitcase Bluetooth Turntable)

### 5.2. The Requirement For Section 15.247(a)(1)

Section 15.247(a)(1): Frequency hopping systems shall have hopping channel carrier frequencies separated by a minimum of 25 kHz or the 20 dB bandwidth of the hopping channel, whichever is greater.

### 5.3. EUT Configuration on Measurement

The equipment are installed on the emission measurement to meet the commission requirements and operating regulations in a manner which tends to maximize its emission characteristics in normal application.

### 5.4. Operating Condition of EUT

5.4.1. Setup the EUT and simulator as shown as Section 5.1.

5.4.2. Turn on the power of all equipment.

5.4.3. Let the EUT work in TX (Hopping off) modes measure it. The transmit frequency are 2402-2480MHz. We select 2402MHz, 2441MHz, and 2480MHz TX frequency to transmit.

### 5.5. Test Procedure

5.5.1. The transmitter output was connected to the spectrum analyzer through a low loss cable.

5.5.2. Set RBW of spectrum analyzer to 30 kHz and VBW to 100 kHz.

5.5.3. The 20dB bandwidth is defined as the total spectrum the power of which is higher than peak power minus 20dB.

### 5.6. Test Result

Channel	Frequency (MHz)	GFSK 20dB Bandwidth (MHz)	$\Pi/4$ -DQPSK 20dB Bandwidth (MHz)	8DPSK 20dB Bandwidth (MHz)	Result
Low	2402	0.864	1.220	1.208	Pass
Middle	2441	0.872	1.220	1.212	Pass
High	2480	0.852	1.224	1.212	Pass

The spectrum analyzer plots are attached as below.

GFSK Mode

Low channel

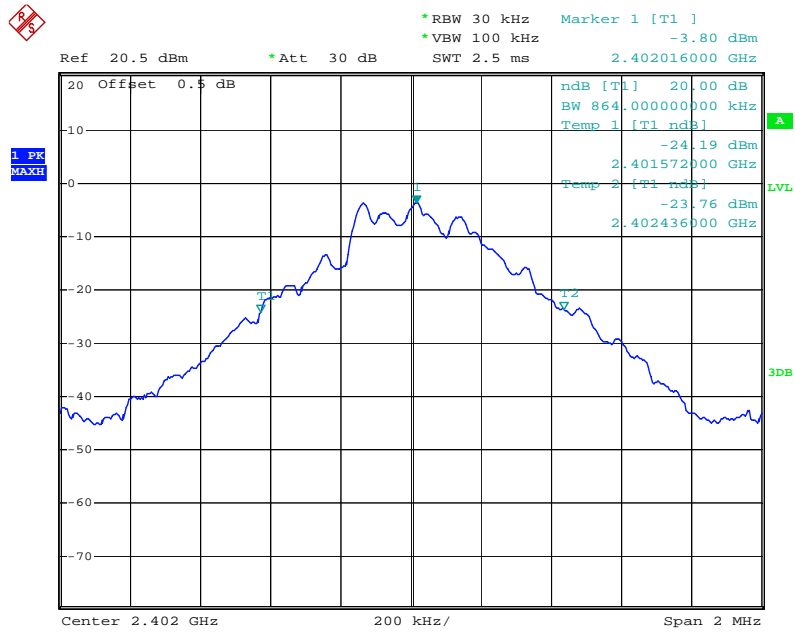

Middle channel

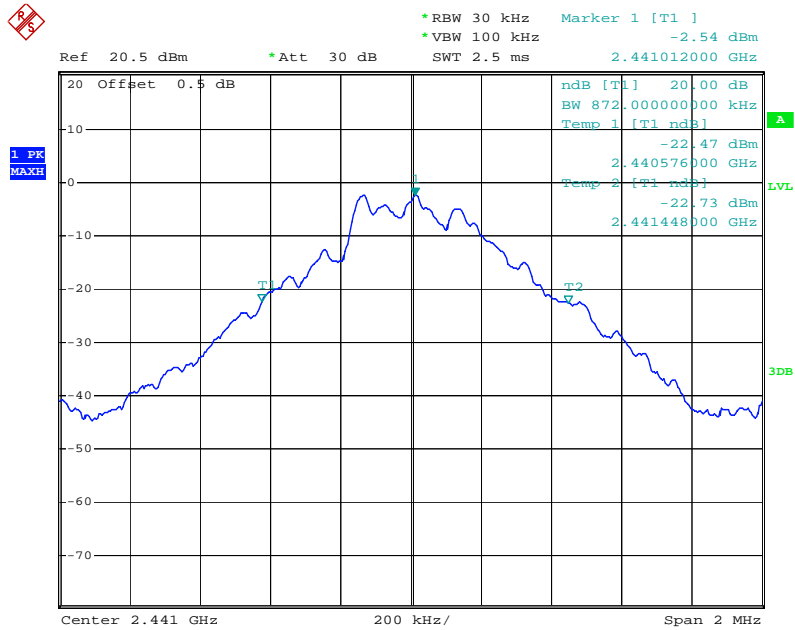

### High channel

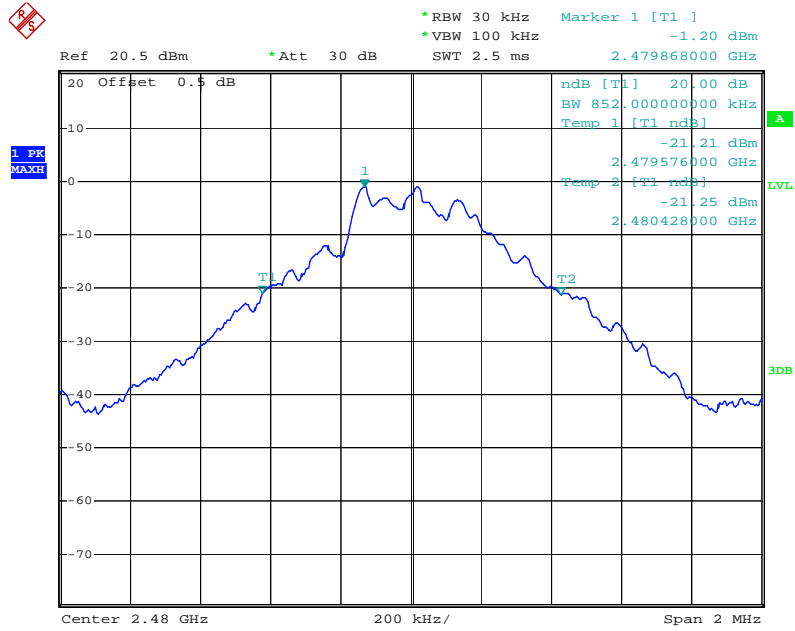

### Π/4-DQPSK Mode

### Low channel

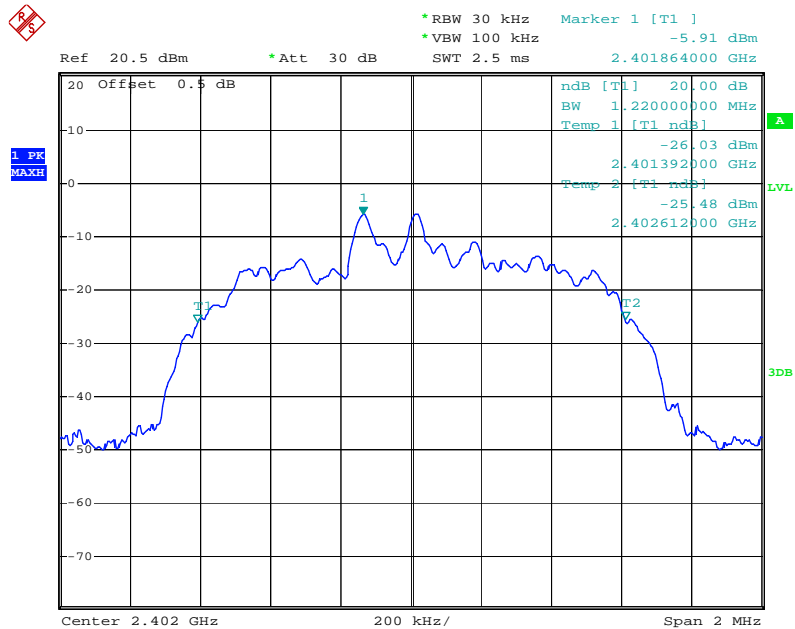

### Middle channel

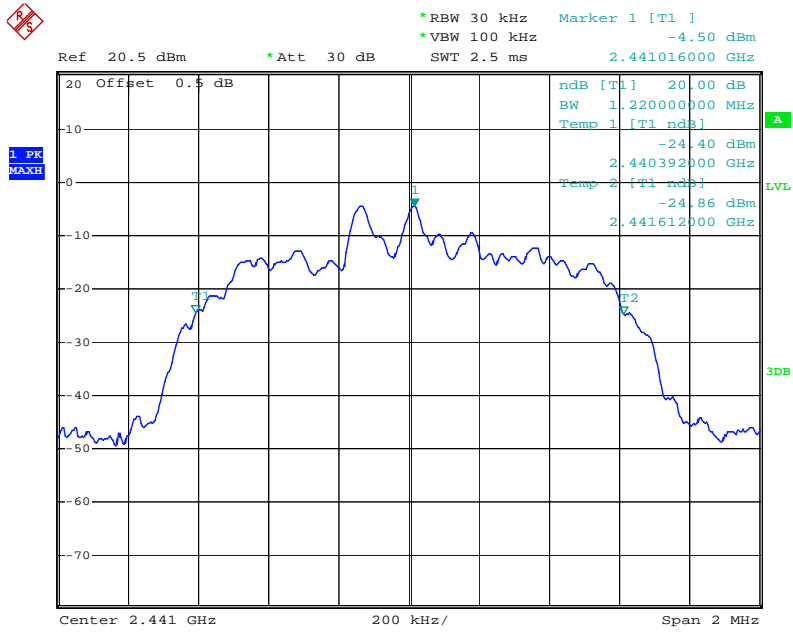

### High channel

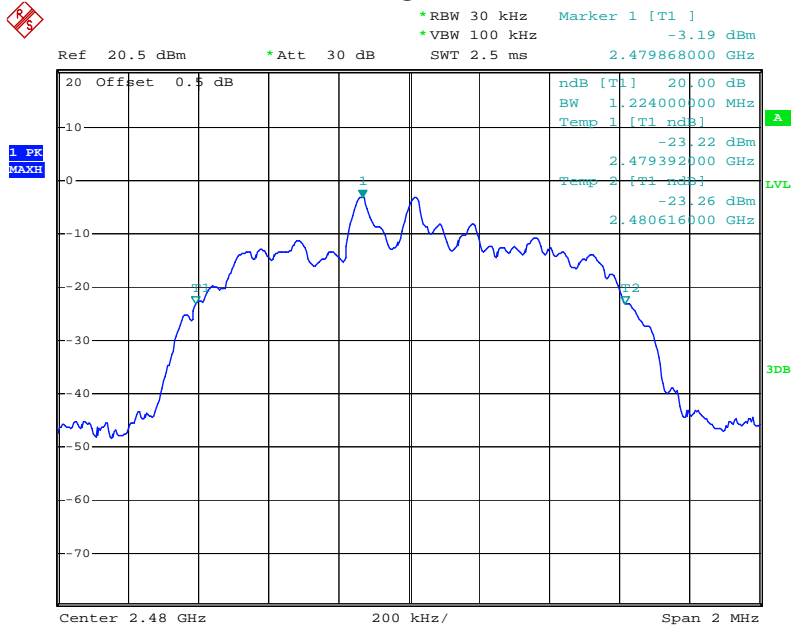

8DPSK Mode

### Low channel

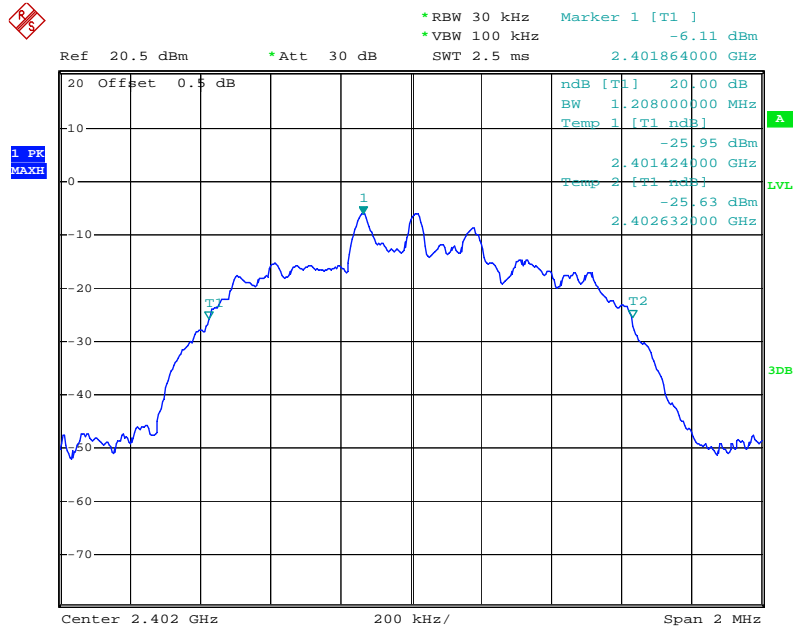

### Middle channel

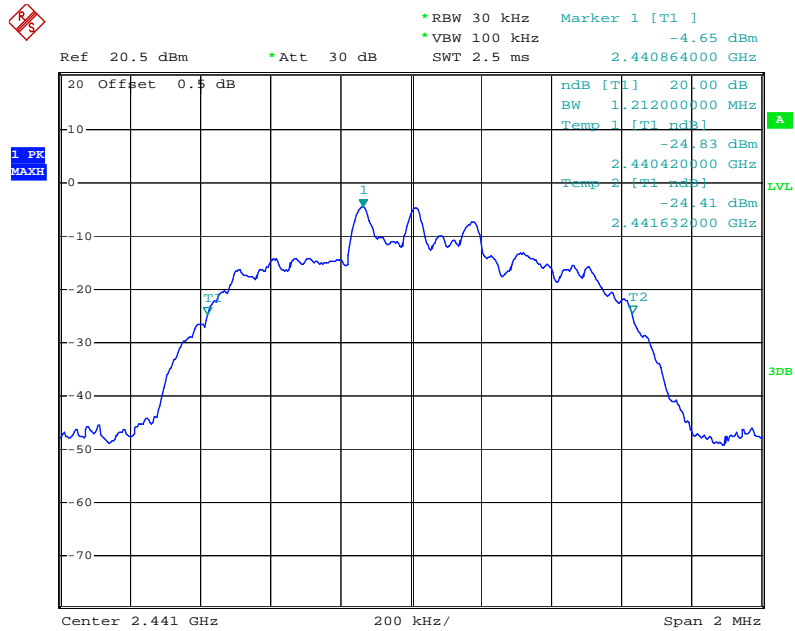

### High channel

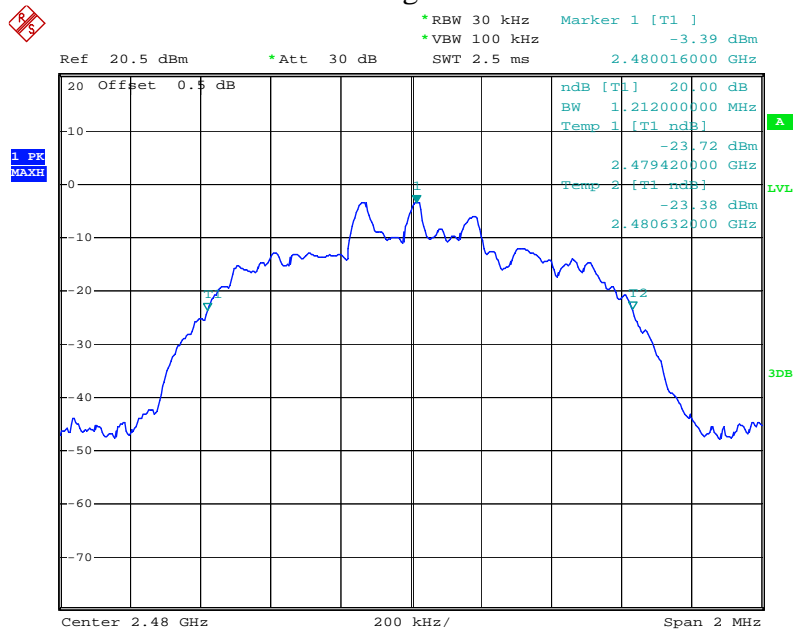



## 6. CARRIER FREQUENCY SEPARATION TEST

### 6.1. Block Diagram of Test Setup



(EUT: Suitcase Bluetooth Turntable)

### 6.2. The Requirement For Section 15.247(a)(1)

Section 15.247(a)(1): Frequency hopping systems shall have hopping channel carrier frequencies separated by a minimum of 25 kHz or the 20 dB bandwidth of the hopping channel, whichever is greater. Alternatively, frequency hopping systems operating in the 2400-2483.5 MHz band may have hopping channel carrier frequencies that are separated by 25 kHz or two-thirds of the 20 dB bandwidth of the hopping channel, whichever is greater, provided the systems operate with an output power no greater than 125 mW. The system shall hop to channel frequencies that are selected at the system hopping rate from a pseudorandomly ordered list of hopping frequencies. Each frequency must be used equally on the average by each transmitter. The system receivers shall have input bandwidths that match the hopping channel bandwidths of their corresponding transmitters and shall shift frequencies in synchronization with the transmitted signals.

### 6.3. EUT Configuration on Measurement

The equipment are installed on the emission measurement to meet the commission requirements and operating regulations in a manner which tends to maximize its emission characteristics in normal application.

### 6.4. Operating Condition of EUT

6.4.1. Setup the EUT and simulator as shown as Section 6.1.

6.4.2. Turn on the power of all equipment.

6.4.3. Let the EUT work in TX (Hopping on) modes measure it. The transmit frequency are 2402-2480MHz. We select 2402MHz, 2441MHz, and 2480MHz TX frequency to transmit.

## 6.5. Test Procedure

6.5.1. The transmitter output was connected to the spectrum analyzer through a low loss cable.

6.5.2. Set RBW of spectrum analyzer to 100 kHz and VBW to 300 kHz. Adjust Span to 3 MHz.

6.5.3. Set the adjacent channel of the EUT maxhold another trace.

6.5.4. Measurement the channel separation

## 6.6. Test Result

### GFSK

Channel	Frequency (MHz)	Channel Separation(MHz)	Limit (MHz)	Result
Low	2402	1.026	25KHz or 20dB bandwidth	PASS
	2403			
Middle	2440	1.008	25KHz or 20dB bandwidth	PASS
	2441			
High	2479	1.002	25KHz or 20dB bandwidth	PASS
	2480			

### Π/4-DQPSK

Channel	Frequency (MHz)	Channel Separation(MHz)	Limit (MHz)	Result
Low	2402	1.002	25KHz or 2/3*20dB bandwidth	PASS
	2403			
Middle	2440	1.020	25KHz or 2/3*20dB bandwidth	PASS
	2441			
High	2479	1.008	25KHz or 2/3*20dB bandwidth	PASS
	2480			

### 8DPSK

Channel	Frequency (MHz)	Channel Separation(MHz)	Limit (MHz)	Result
Low	2402	1.002	25KHz or 2/3*20dB bandwidth	PASS
	2403			
Middle	2440	1.008	25KHz or 2/3*20dB bandwidth	PASS
	2441			
High	2479	1.002	25KHz or 2/3*20dB bandwidth	PASS
	2480			

The spectrum analyzer plots are attached as below.

## GFSK Mode

### Low channel

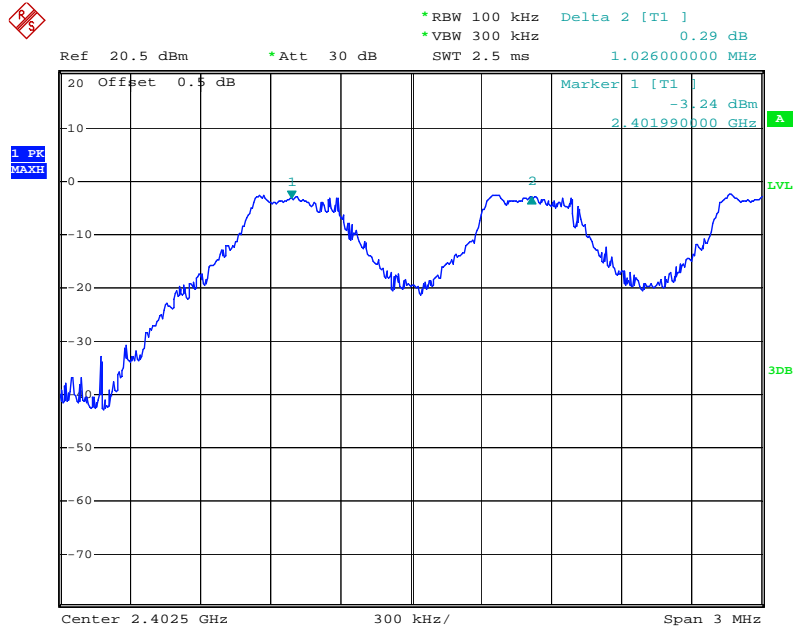

### Middle channel

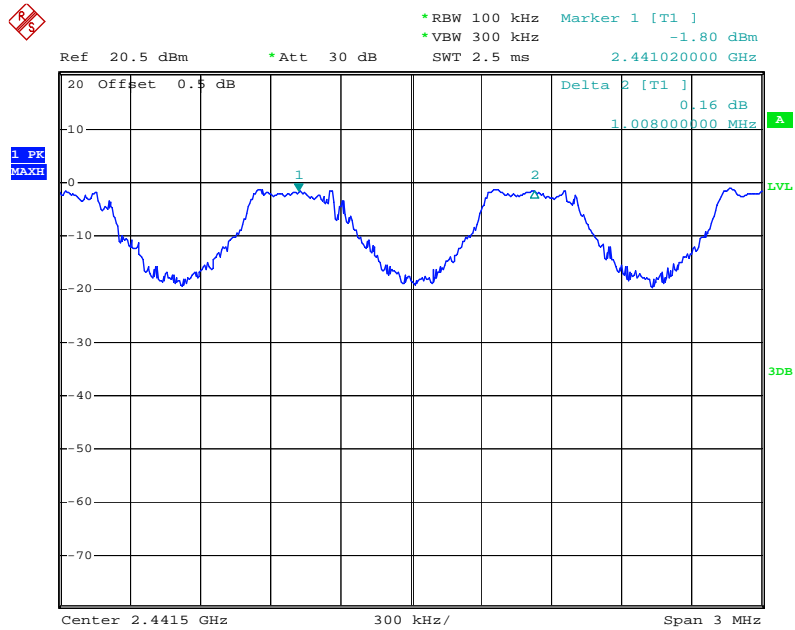

### High channel

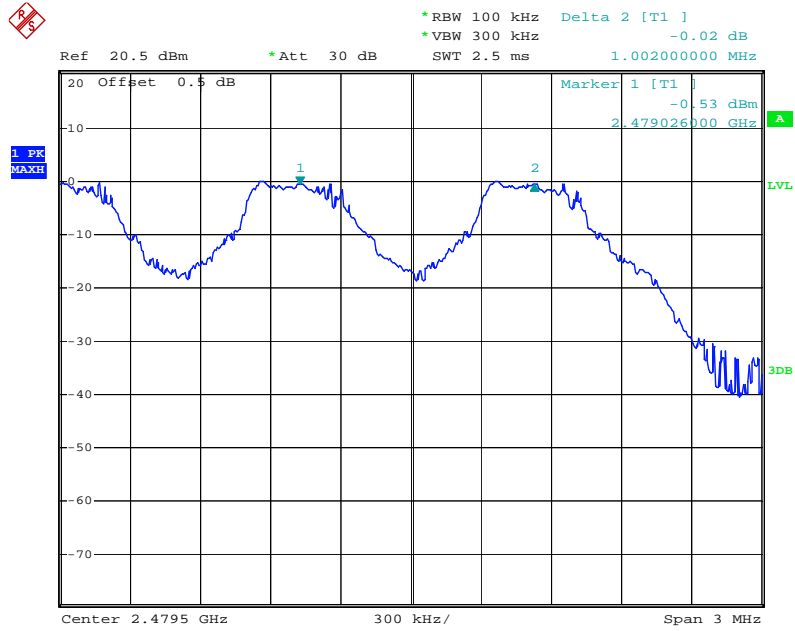

### $\Pi/4$ -DQPSK Mode

### Low channel

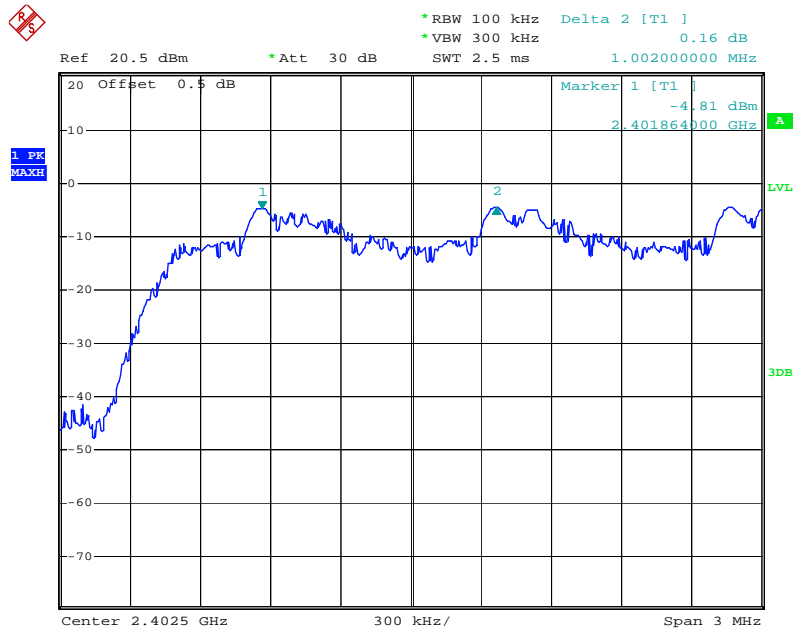

### Middle channel

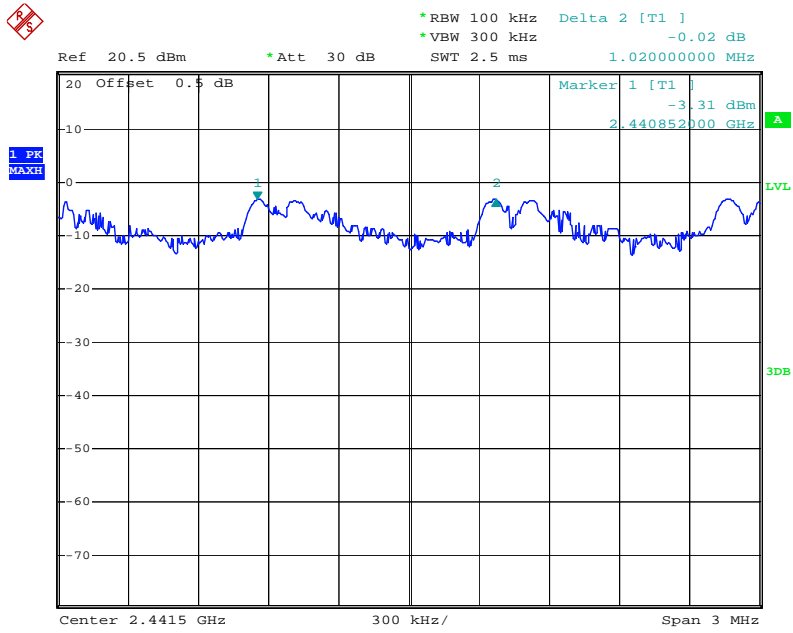

### High channel

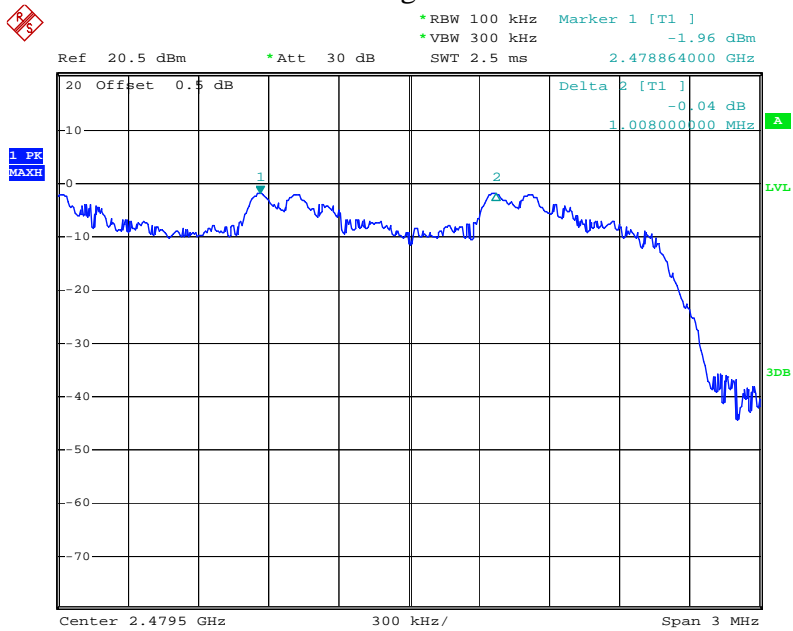

## 8DPSK Mode

### Low channel

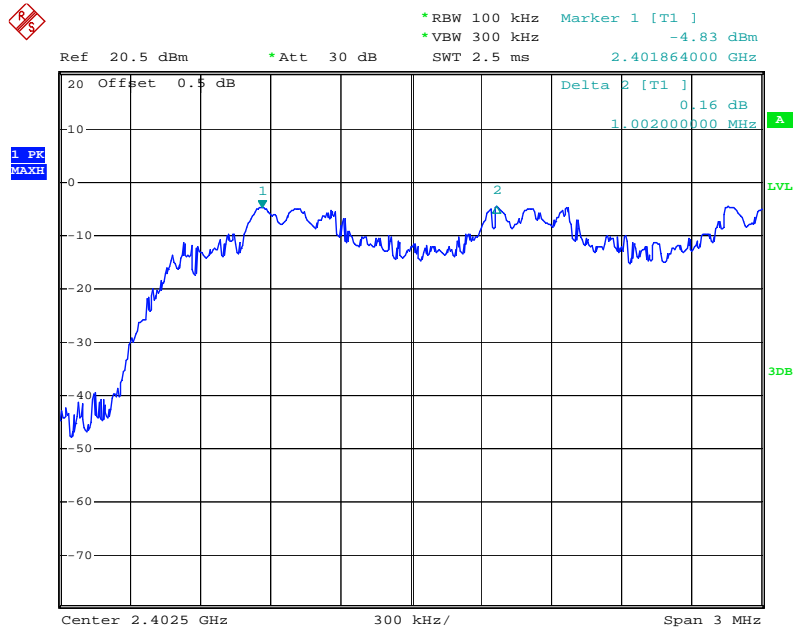

### Middle channel

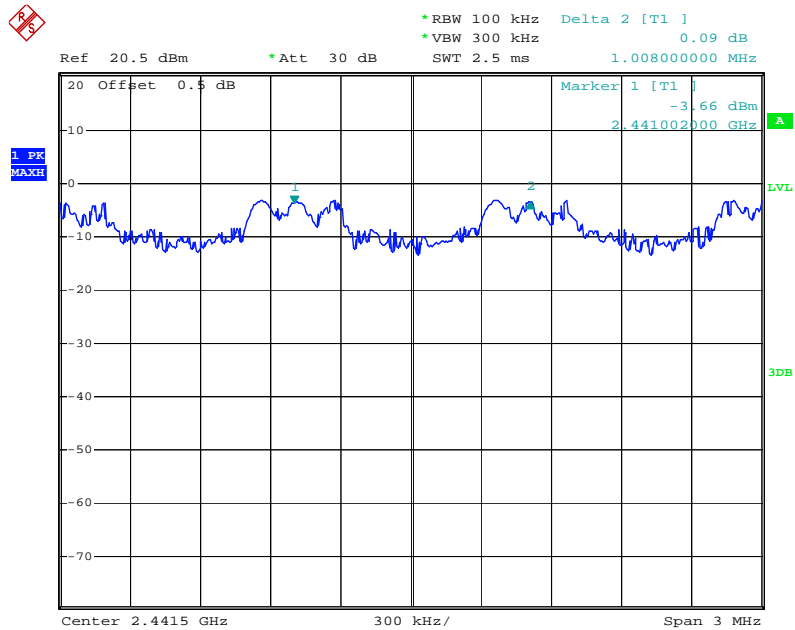

### High channel

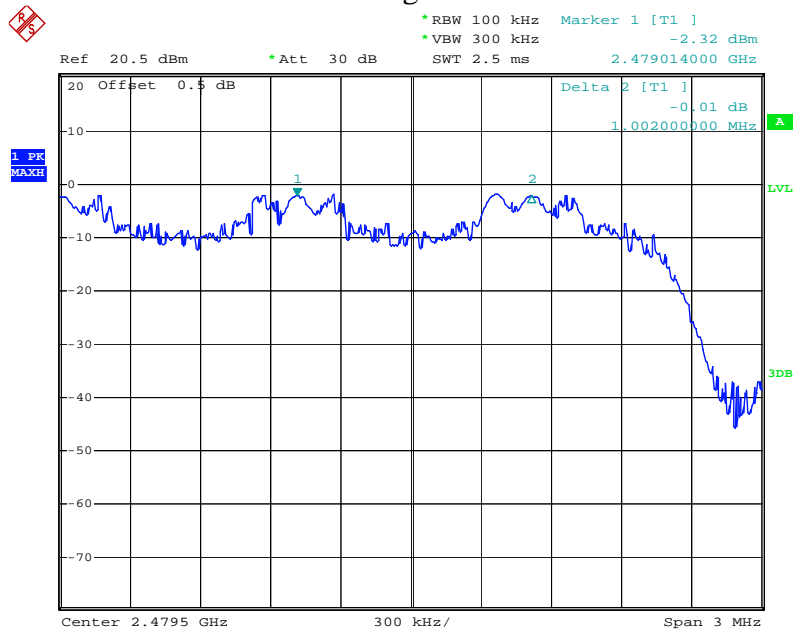

## 7. NUMBER OF HOPPING FREQUENCY TEST

### 7.1. Block Diagram of Test Setup



(EUT: Suitcase Bluetooth Turntable)

### 7.2. The Requirement For Section 15.247(a)(1)(iii)

Section 15.247(a)(1)(iii): Frequency hopping systems in the 2400-2483.5 MHz band shall use at least 15 channels.

### 7.3. EUT Configuration on Measurement

The equipment are installed on the emission measurement to meet the commission requirements and operating regulations in a manner which tends to maximize its emission characteristics in normal application.

### 7.4. Operating Condition of EUT

7.4.1. Setup the EUT and simulator as shown as Section 7.1.

7.4.2. Turn on the power of all equipment.

7.4.3. Let the EUT work in TX (Hopping on) modes measure it.

### 7.5. Test Procedure

7.5.1. The transmitter output was connected to the spectrum analyzer through a low loss cable.

7.5.2. Set the spectrum analyzer as Span=83.5MHz, RBW=100 kHz, VBW=300 kHz.

7.5.3. Max hold, view and count how many channel in the band.



### 7.6. Test Result

Total number of hopping channel	Measurement result(CH)	Limit(CH)
		79

The spectrum analyzer plots are attached as below.

Number of hopping channels(GFSK)

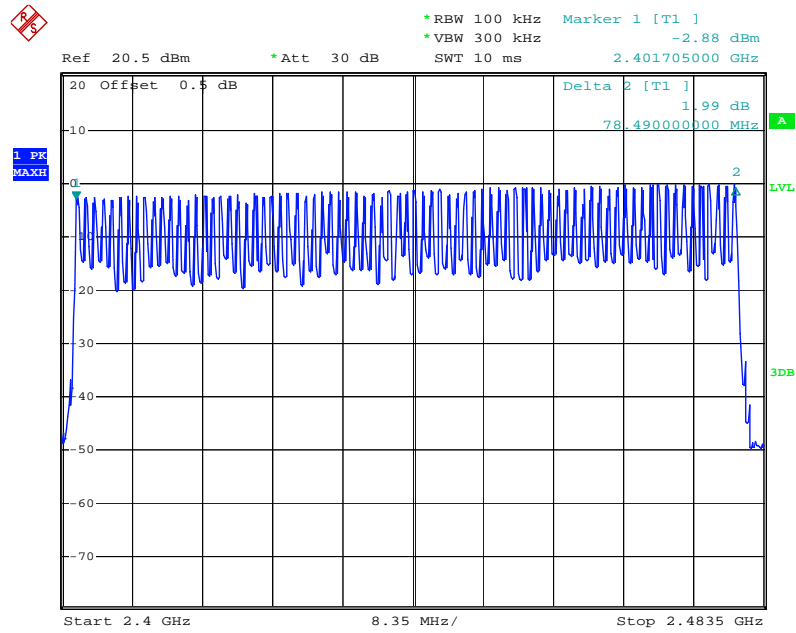

### Number of hopping channels( $\Pi/4$ -DQPSK)

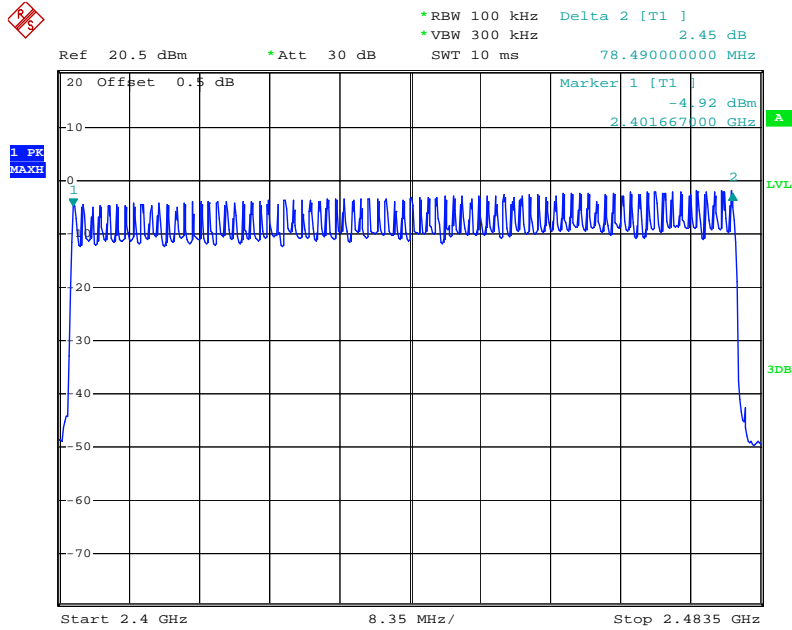

### Number of hopping channels(8DPSK)

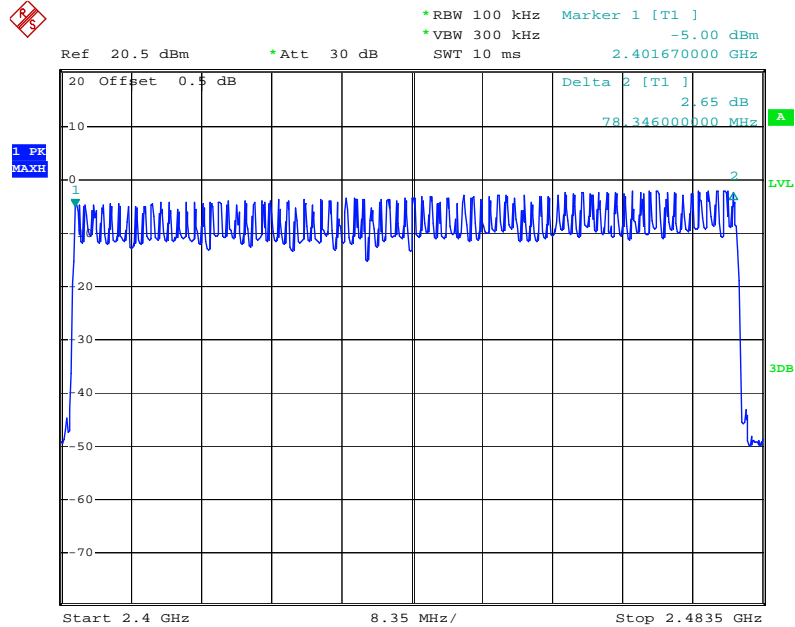

## 8. DWELL TIME TEST

### 8.1. Block Diagram of Test Setup

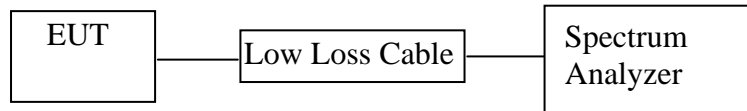

(EUT: Suitcase Bluetooth Turntable)

### 8.2. The Requirement For Section 15.247(a)(1)(iii)

Section 15.247(a)(1)(iii): Frequency hopping systems in the 2400-2483.5 MHz band shall use at least 15 channels. The average time of occupancy on any channel shall not be greater than 0.4 seconds within a period of 0.4 seconds multiplied by the number of hopping channels employed. Frequency hopping systems may avoid or suppress transmissions on a particular hopping frequency provided that a minimum of 15 channels are used.

### 8.3. EUT Configuration on Measurement

The equipment are installed on the emission measurement to meet the commission requirements and operating regulations in a manner which tends to maximize its emission characteristics in normal application.

### 8.4. Operating Condition of EUT

8.4.1. Setup the EUT and simulator as shown as Section 8.1.

8.4.2. Turn on the power of all equipment.

8.4.3. Let the EUT work in TX (Hopping on) modes measure it. The transmit frequency are 2402-2480MHz. We select 2402MHz, 2441MHz, and 2480MHz TX frequency to transmit.

### 8.5. Test Procedure

8.5.1. The transmitter output was connected to the spectrum analyzer through a low loss cable.

8.5.2. Set center frequency of spectrum analyzer = operating frequency.

8.5.3. Set the spectrum analyzer as RBW=1MHz, VBW=3MHz, Span=0Hz, Adjust Sweep=5ms, 10ms, 15ms. Get the pulse time.

8.5.4.Repeat above procedures until all frequency measured were complete.

## 8.6.Test Result

### GFSK Mode

Mode	Channel Frequency (MHz)	Pulse Time (ms)	Dwell Time (ms)	Limit (ms)
DH1	2402	0.415	132.80	400
	2441	0.410	131.20	400
	2480	0.415	132.80	400
A period transmit time = $0.4 \times 79 = 31.6$ Dwell time = pulse time $\times (1600/(2*79)) \times 31.6$				
DH3	2402	1.680	268.80	400
	2441	1.695	271.20	400
	2480	1.680	268.80	400
A period transmit time = $0.4 \times 79 = 31.6$ Dwell time = pulse time $\times (1600/(4*79)) \times 31.6$				
DH5	2402	2.960	315.73	400
	2441	2.960	315.73	400
	2480	2.960	315.73	400
A period transmit time = $0.4 \times 79 = 31.6$ Dwell time = pulse time $\times (1600/(6*79)) \times 31.6$				

### $\Pi/4$ -DQPSK

Mode	Channel Frequency (MHz)	Pulse Time (ms)	Dwell Time (ms)	Limit (ms)
DH1	2402	0.450	144.00	400
	2441	0.450	144.00	400
	2480	0.440	140.80	400
A period transmit time = $0.4 \times 79 = 31.6$ Dwell time = pulse time $\times (1600/(2*79)) \times 31.6$				
DH3	2402	1.740	278.40	400
	2441	1.740	278.40	400
	2480	1.720	275.20	400
A period transmit time = $0.4 \times 79 = 31.6$ Dwell time = pulse time $\times (1600/(4*79)) \times 31.6$				
DH5	2402	2.970	316.80	400
	2441	2.970	316.80	400
	2480	2.970	316.80	400
A period transmit time = $0.4 \times 79 = 31.6$ Dwell time = pulse time $\times (1600/(6*79)) \times 31.6$				

8DPSK Mode

Mode	Channel Frequency (MHz)	Pulse Time (ms)	Dwell Time (ms)	Limit (ms)
DH1	2402	0.440	140.80	400
	2441	0.440	140.80	400
	2480	0.440	140.80	400
A period transmit time = $0.4 \times 79 = 31.6$ Dwell time = pulse time $\times (1600/(2*79)) \times 31.6$				
DH3	2402	1.680	268.80	400
	2441	1.720	275.20	400
	2480	1.700	272.00	400
A period transmit time = $0.4 \times 79 = 31.6$ Dwell time = pulse time $\times (1600/(4*79)) \times 31.6$				
DH5	2402	3.000	320.00	400
	2441	3.000	320.00	400
	2480	3.030	323.20	400
A period transmit time = $0.4 \times 79 = 31.6$ Dwell time = pulse time $\times (1600/(6*79)) \times 31.6$				

The spectrum analyzer plots are attached as below.

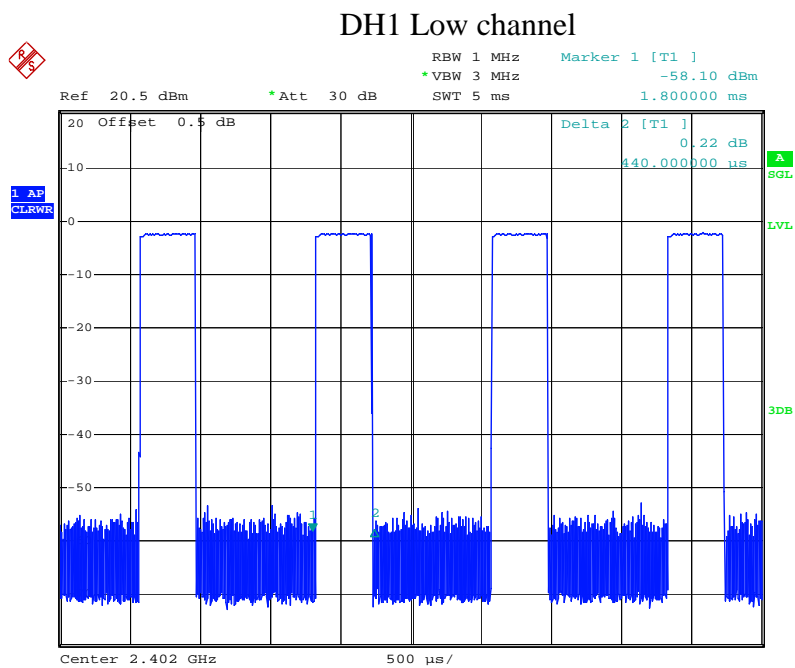

## DH1 Middle channel

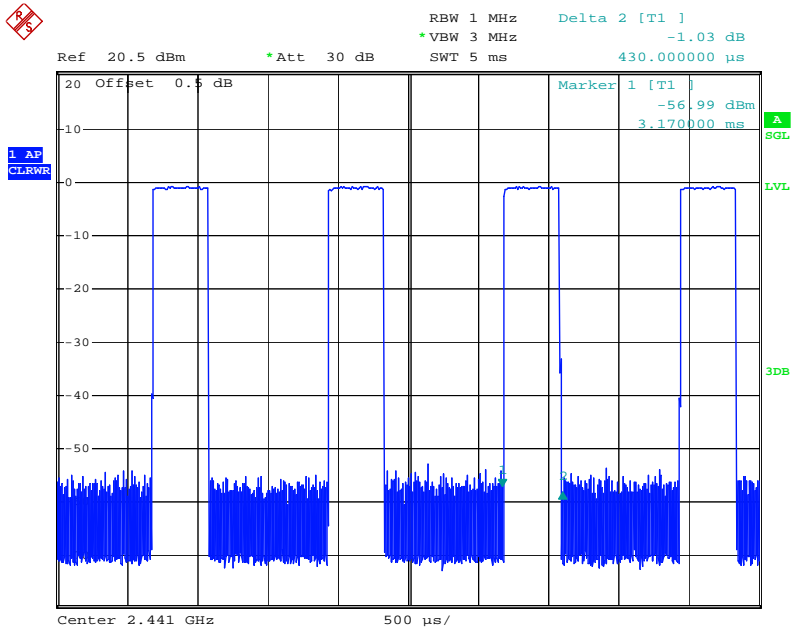

## DH1 High channel

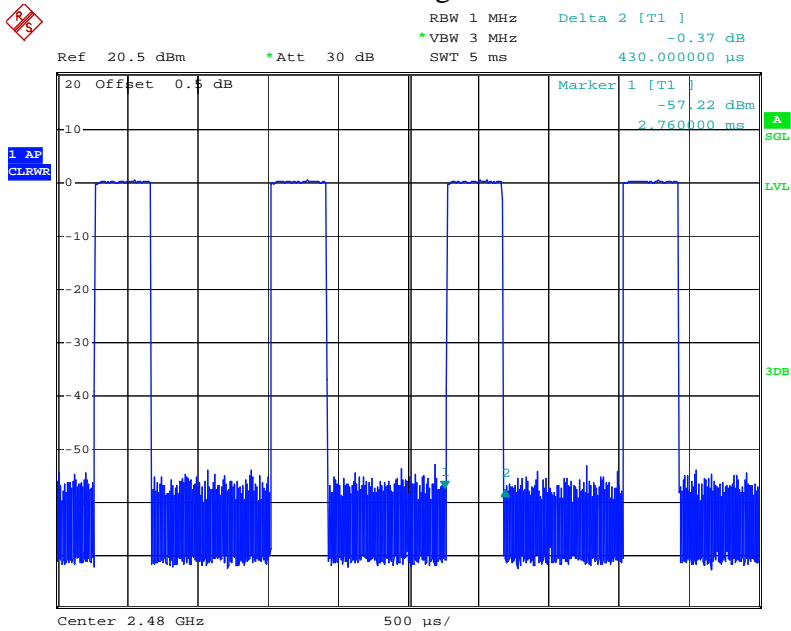

## DH3 Low channel

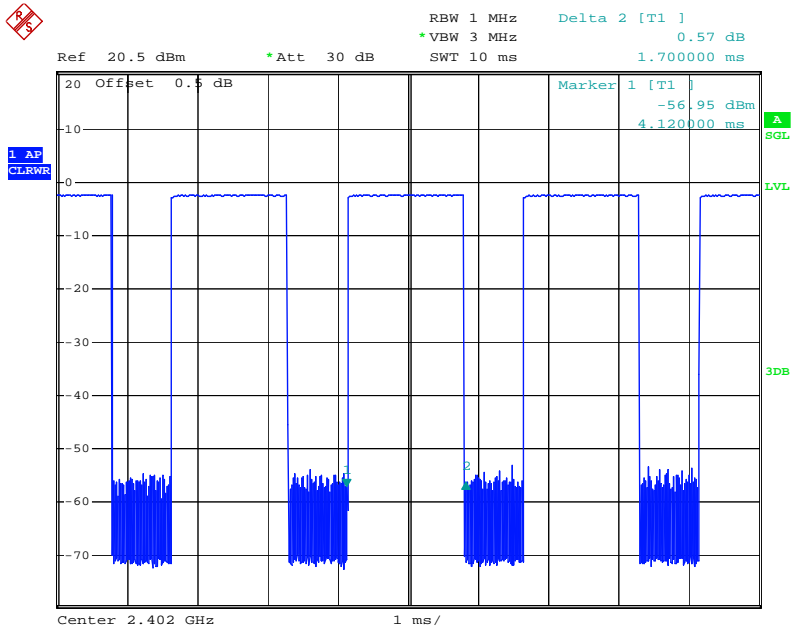

## DH3 Middle channel

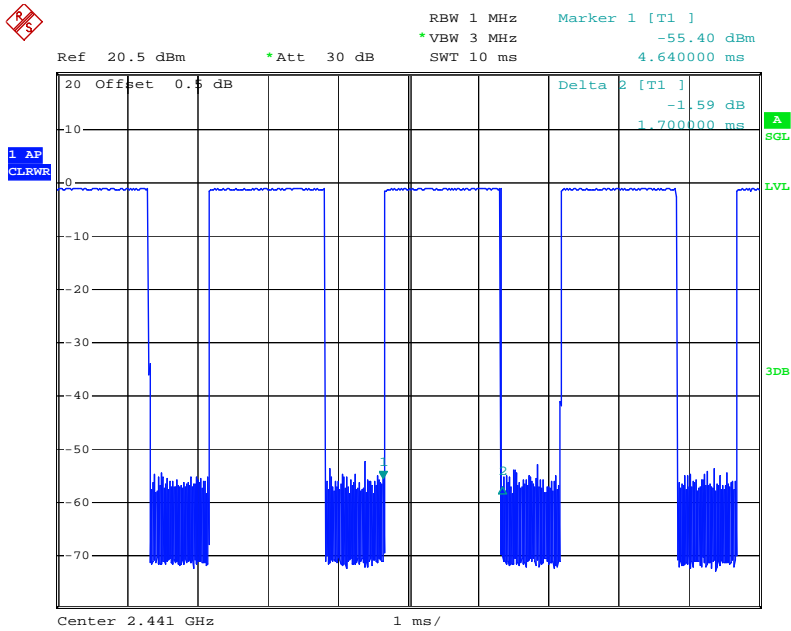

## DH3 High channel

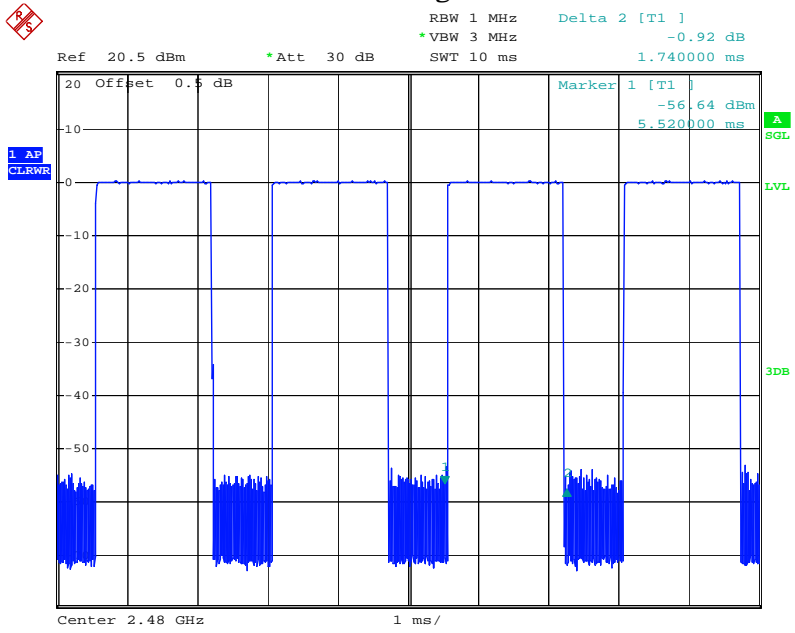

## DH5 Low channel

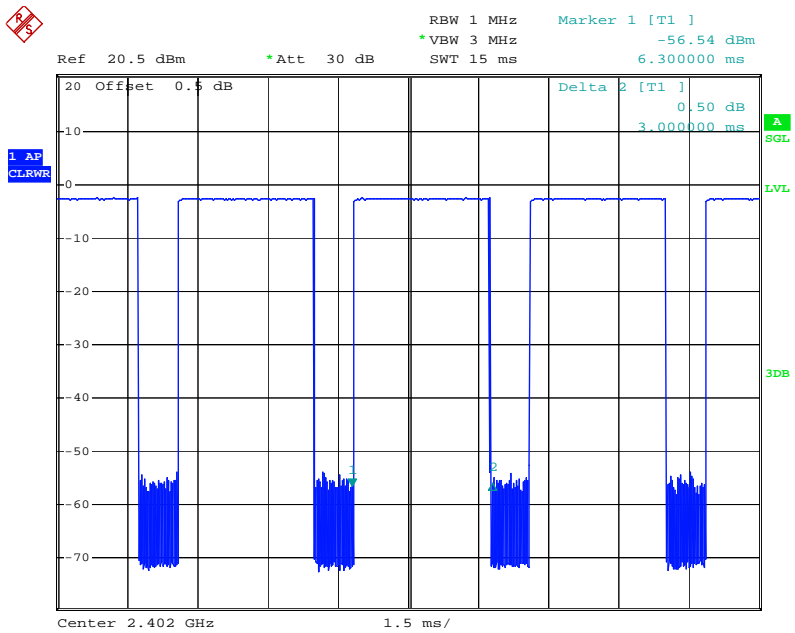



### DH5 Middle channel

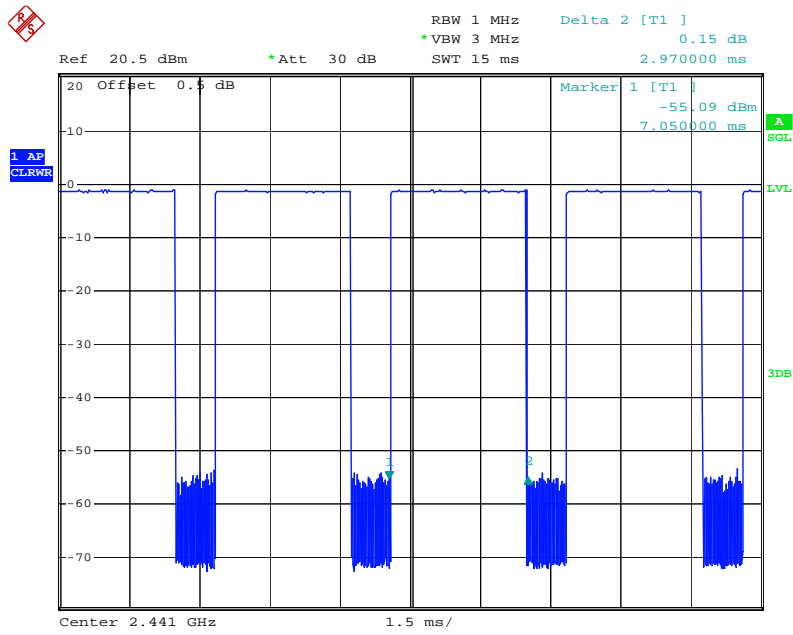

### DH5 High channel

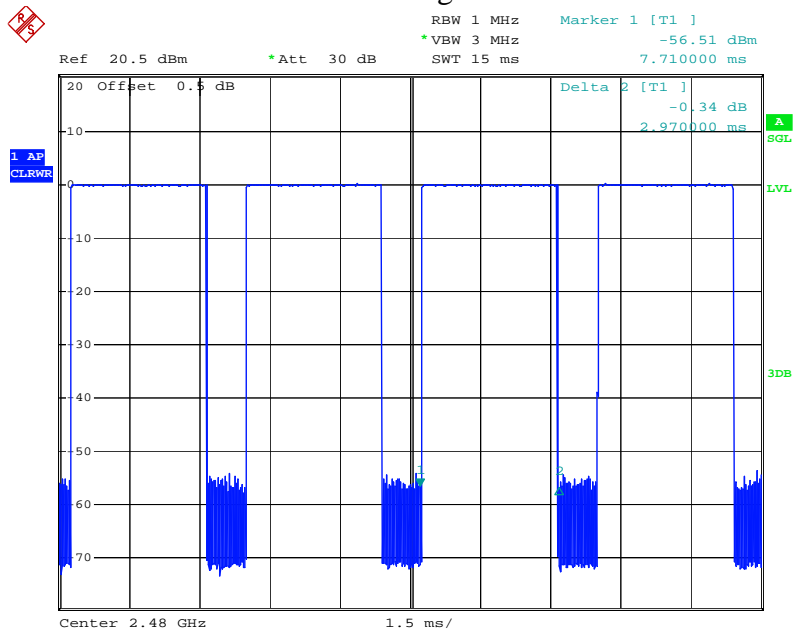

### 2DH1 Low channel

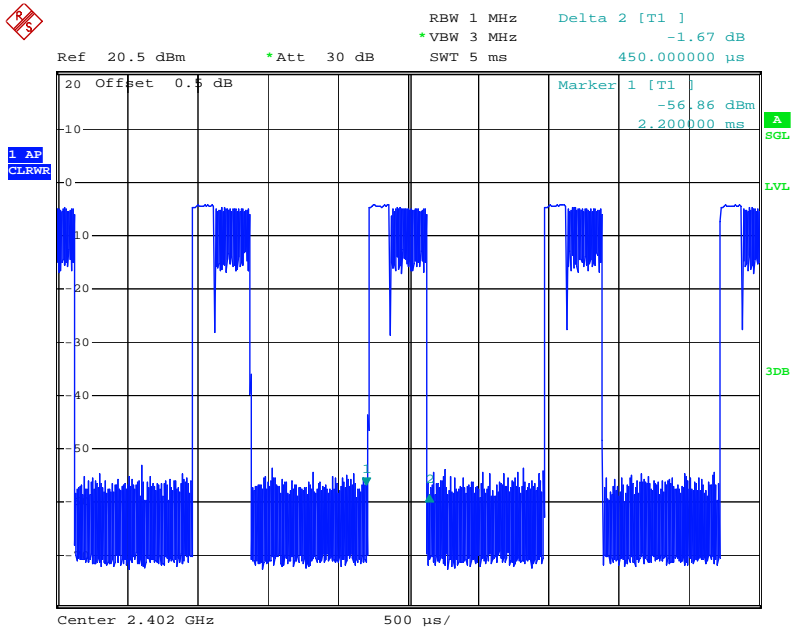

### 2DH1 Middle channel

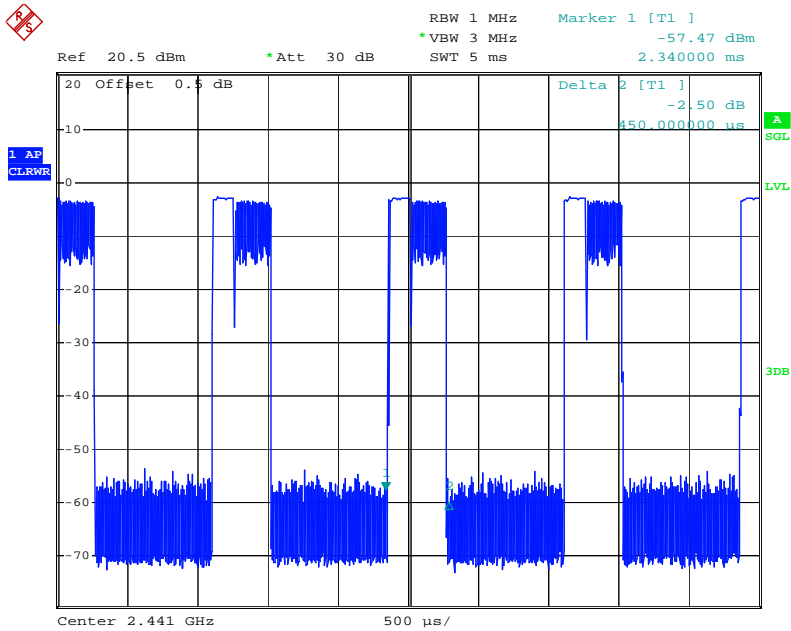

### 2DH1 High channel

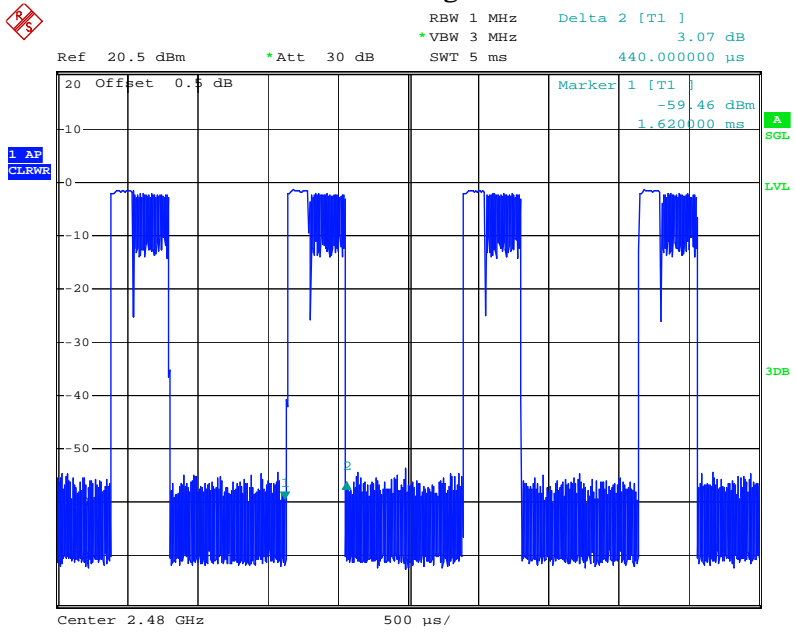

### 2DH3 Low channel

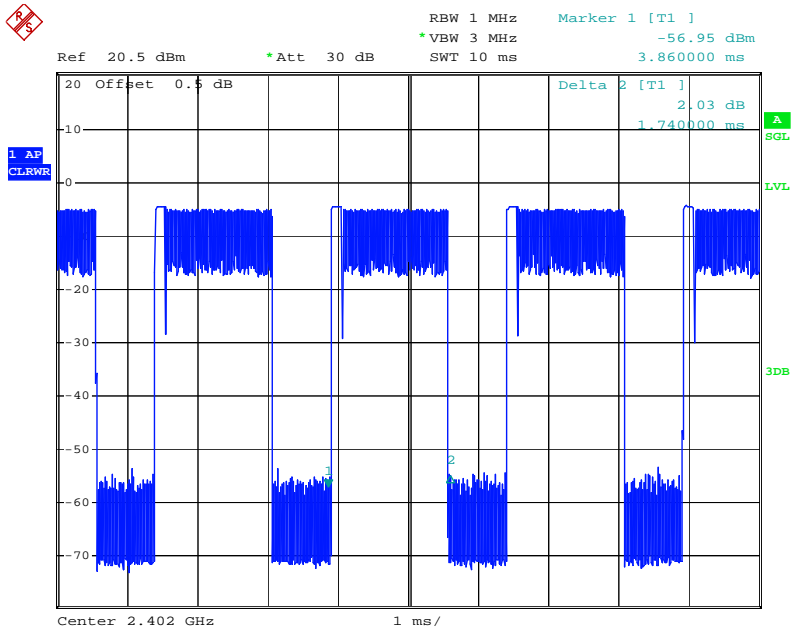

### 2DH3 Middle channel

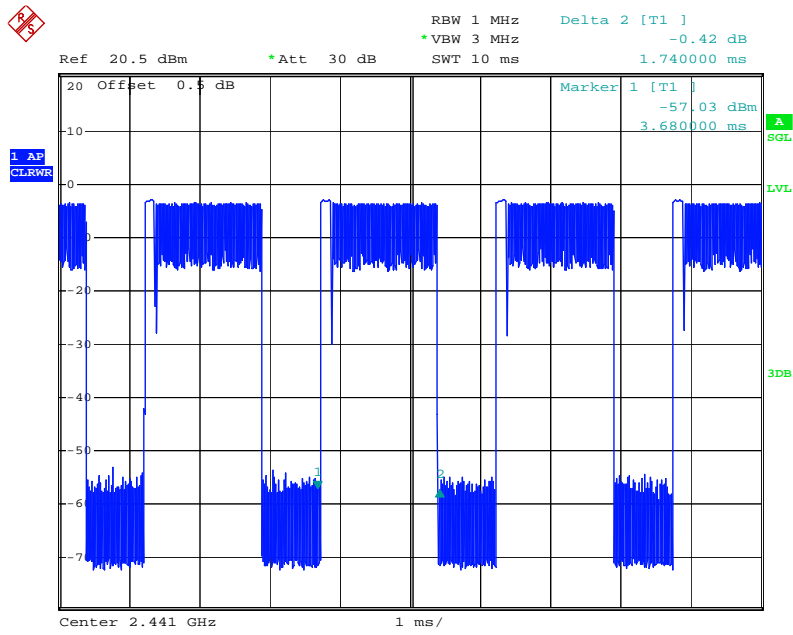

### 2DH3 High channel

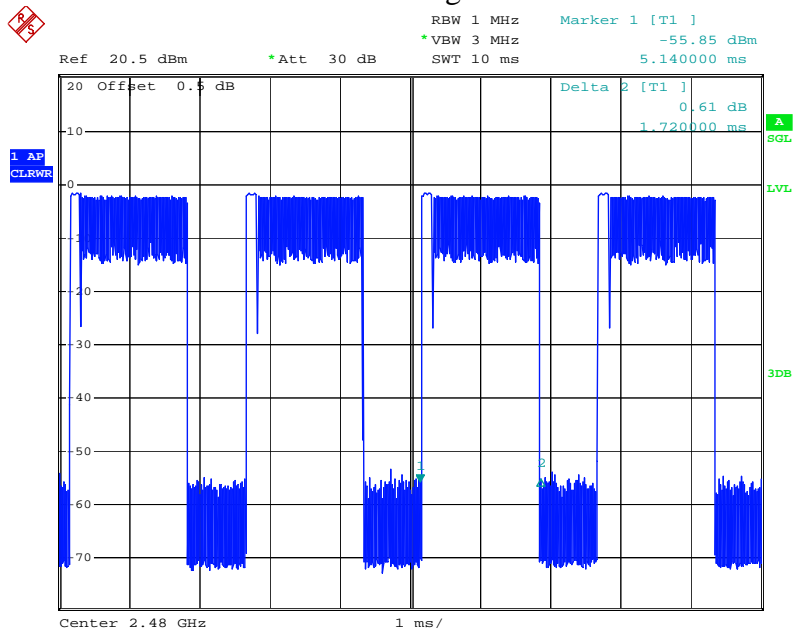

### 2DH5 Low channel

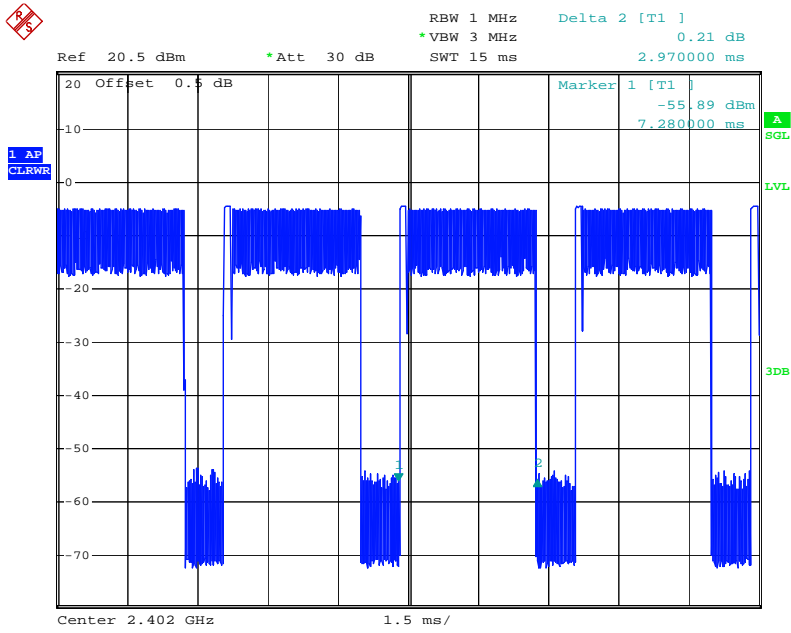

### 2DH5 Middle channel

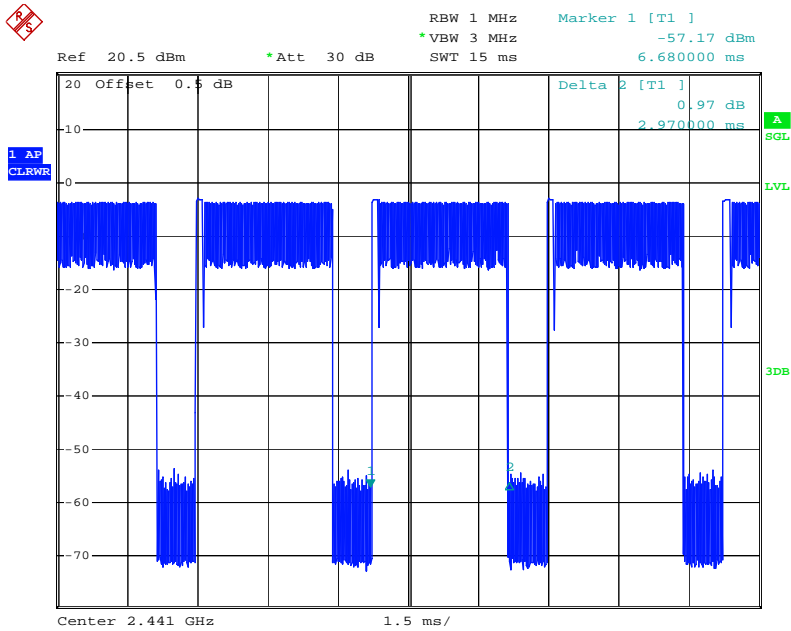

### 2DH5 High channel

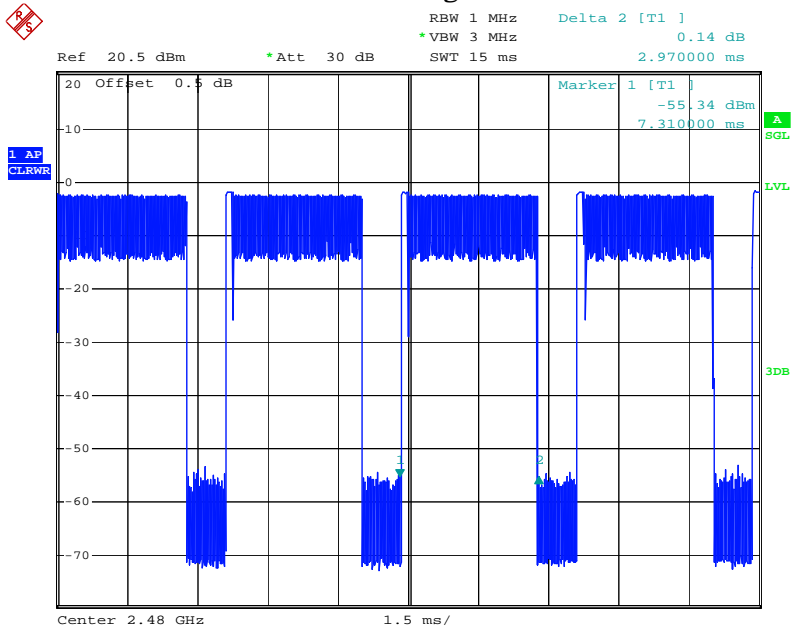

### 3DH1 Low channel

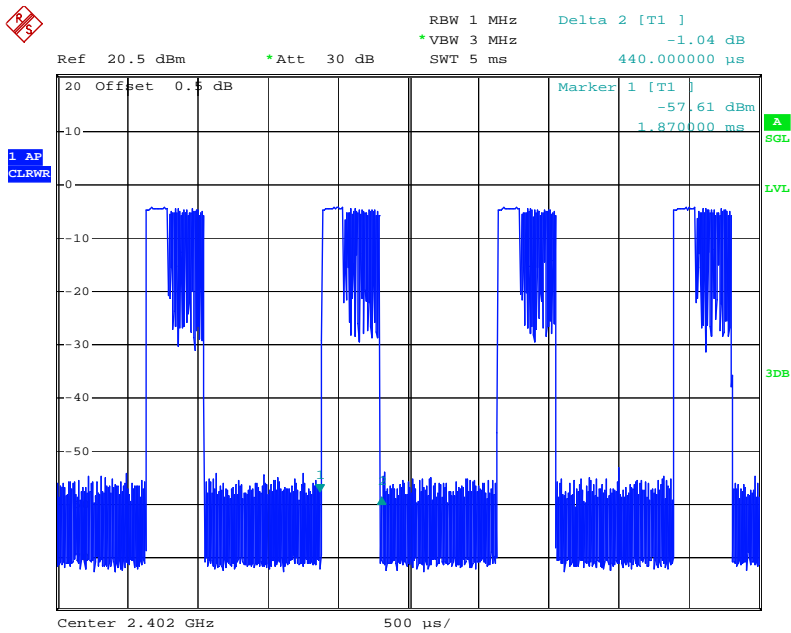

## 3DH1 Middle channel

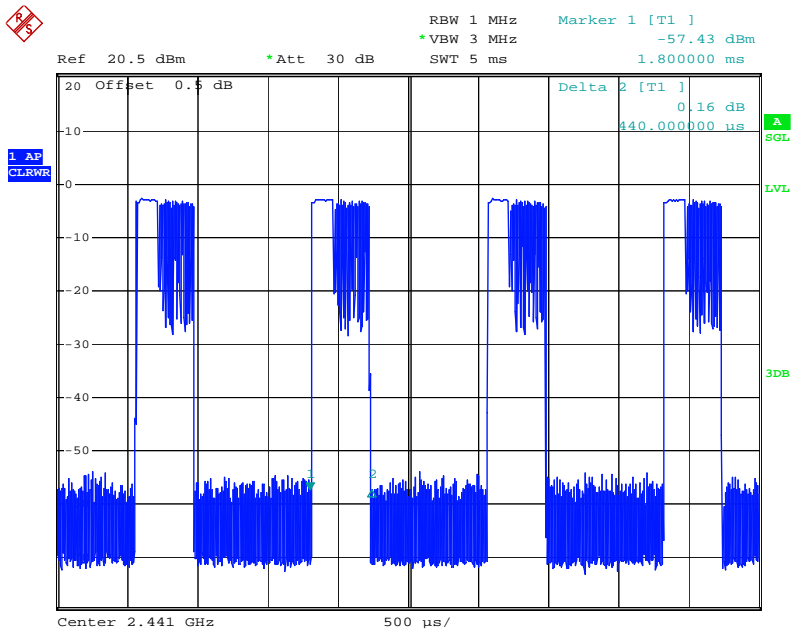

## 3DH1 High channel

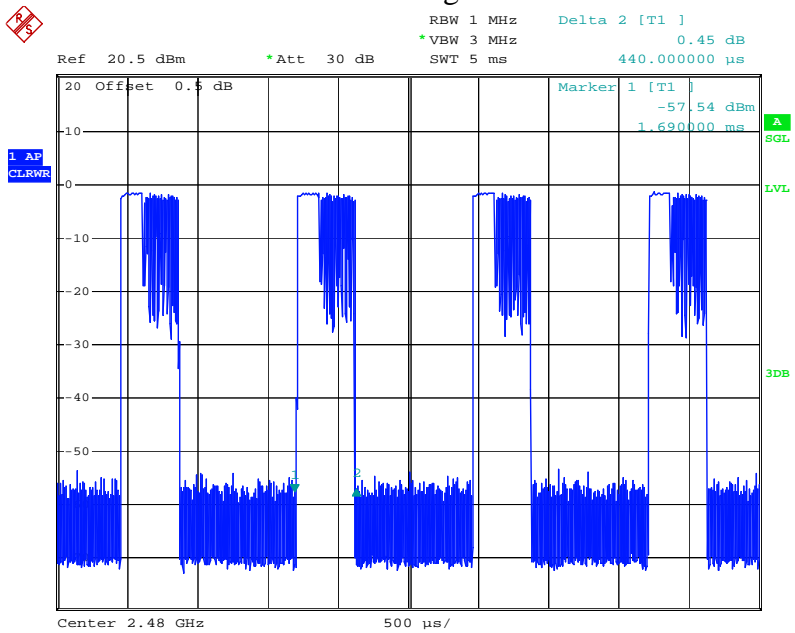

### 3DH3 Low channel

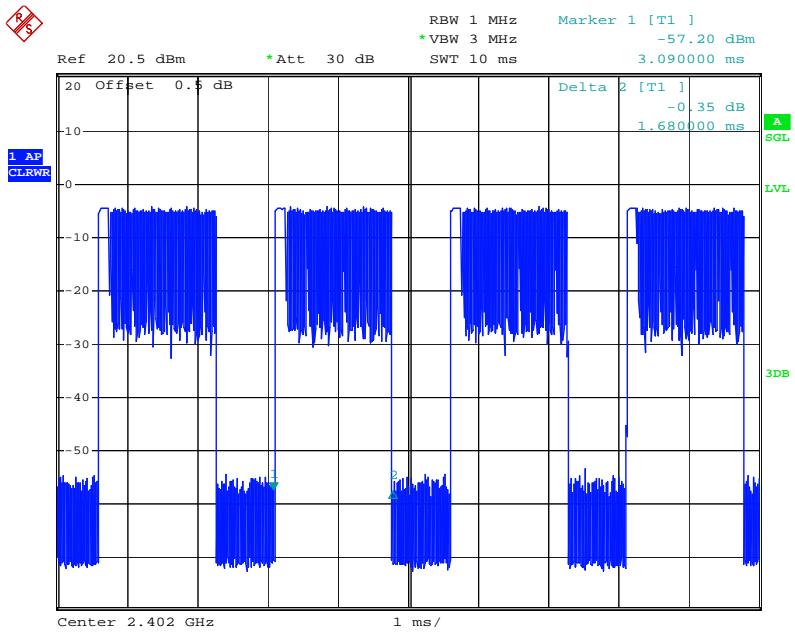

### 3DH3 Middle channel

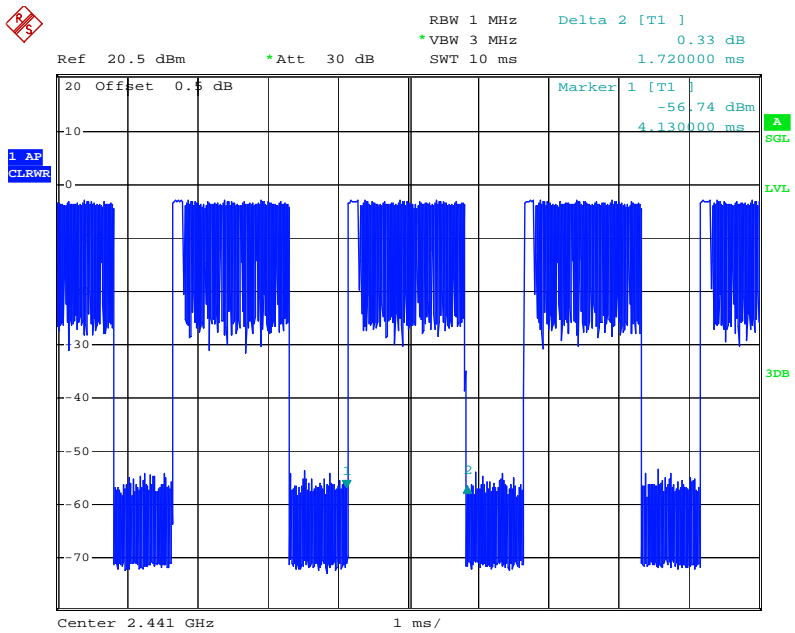



### 3DH3 High channel

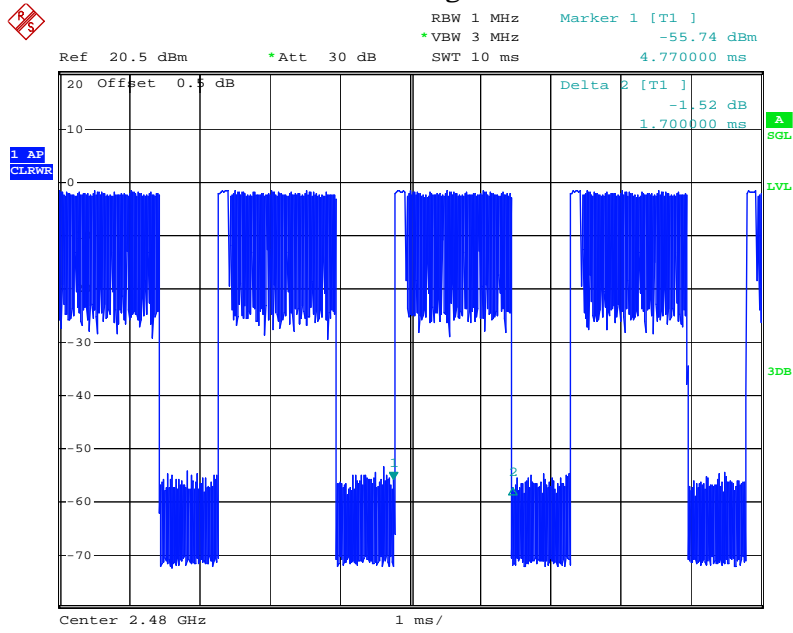

### 3DH5 Low channel

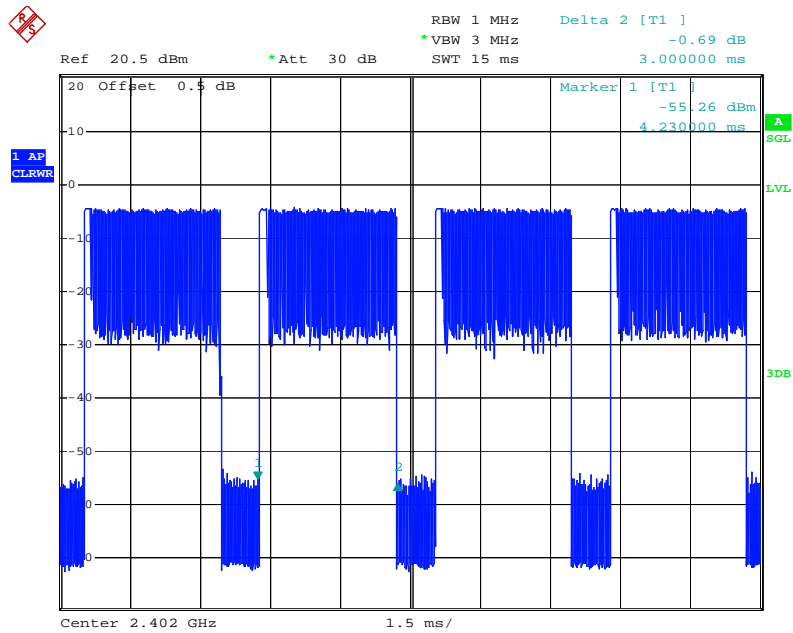

### 3DH5 Middle channel

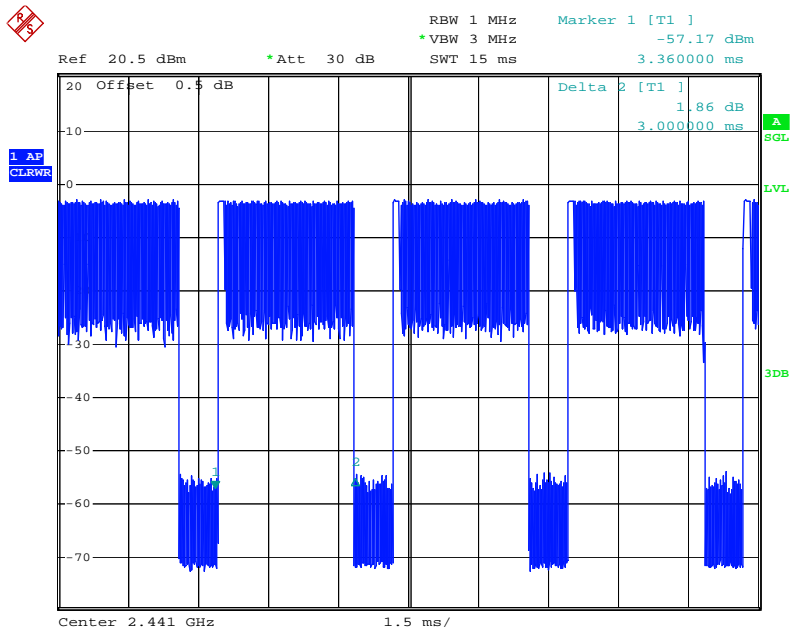

### 3DH5 High channel

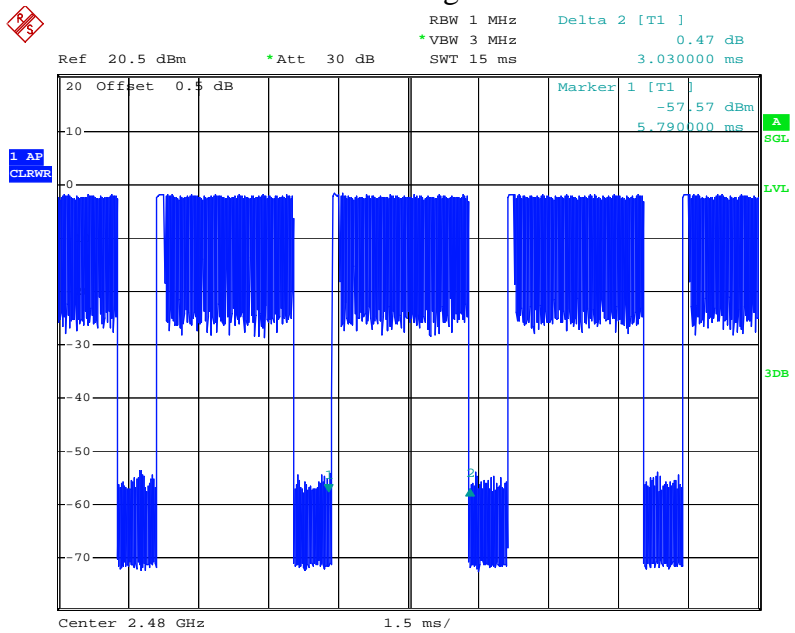

## 9. MAXIMUM PEAK OUTPUT POWER TEST

### 9.1. Block Diagram of Test Setup

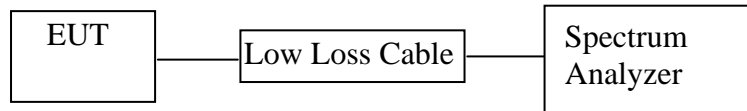

(EUT: Suitcase Bluetooth Turntable)

### 9.2. The Requirement For Section 15.247(b)(1)

Section 15.247(b)(1): For frequency hopping systems operating in the 2400-2483.5 MHz band employing at least 75 non-overlapping hopping channels, and all frequency hopping systems in the 5725-5850 MHz band: 1 watt. For all other frequency hopping systems in the 2400-2483.5 MHz band: 0.125 watts.

### 9.3. EUT Configuration on Measurement

The equipment are installed on the emission Measurement to meet the commission requirements and operating regulations in a manner which tends to maximize its emission characteristics in normal application.

### 9.4. Operating Condition of EUT

9.4.1. Setup the EUT and simulator as shown as Section 9.1.

9.4.2. Turn on the power of all equipment.

9.4.3. Let the EUT work in TX (Hopping off) modes measure it. The transmit frequency are 2402-2480MHz. We select 2402MHz, 2441MHz, and 2480MHz TX frequency to transmit.

### 9.5. Test Procedure

9.5.1. The transmitter output was connected to the spectrum analyzer through a low loss cable.

9.5.2. Set RBW of spectrum analyzer to 1MHz and VBW to 3MHz for GFSK mode

9.5.3. Set RBW of spectrum analyzer to 3MHz and VBW to 3MHz for other mode

9.5.4. Measurement the maximum peak output power.

## 9.6. Test Result

### GFSK Mode

Channel	Frequency (MHz)	Peak Output Power (dBm/W)	Limits dBm / W
Low	2402	-2.09/0.0006	30 / 1.0
Middle	2441	-0.72/0.0008	30 / 1.0
High	2480	0.50/0.0011	30 / 1.0

### Π/4-DQPSK Mode

Channel	Frequency (MHz)	Peak Output Power (dBm/W)	Limits dBm / W
Low	2402	-3.95/0.0004	21 / 0.125
Middle	2441	-2.53/0.0006	21 / 0.125
High	2480	-1.27/0.0007	21 / 0.125

### 8DPSK Mode

Channel	Frequency (MHz)	Peak Output Power (dBm/W)	Limits dBm / W
Low	2402	-3.83/0.0004	21 / 0.125
Middle	2441	-2.43/0.0006	21 / 0.125
High	2480	-1.17/0.0008	21 / 0.125

The spectrum analyzer plots are attached as below.

## GFSK Mode

### Low channel

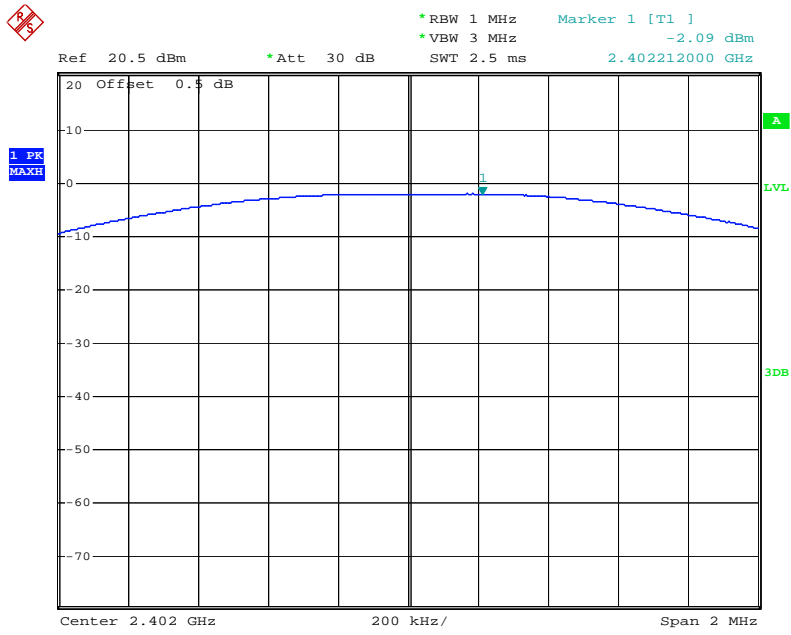

### Middle channel

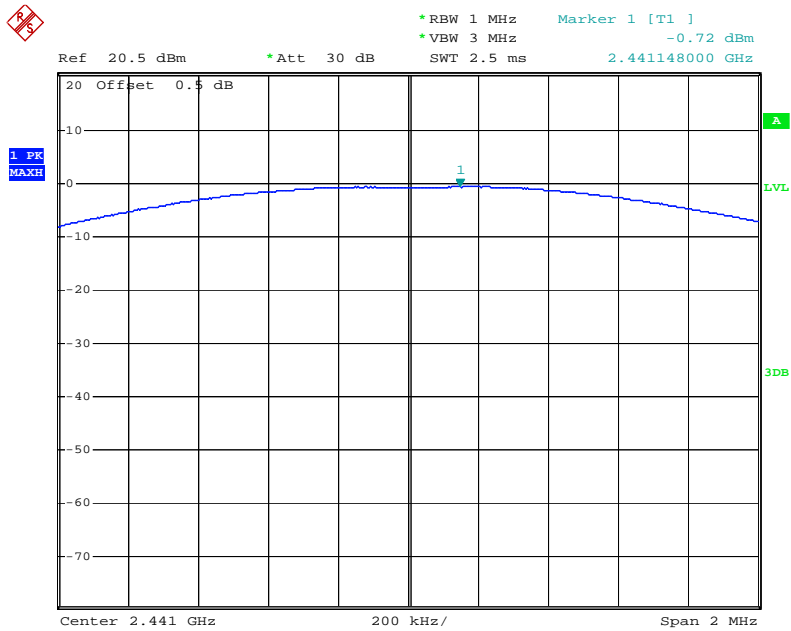

### High channel

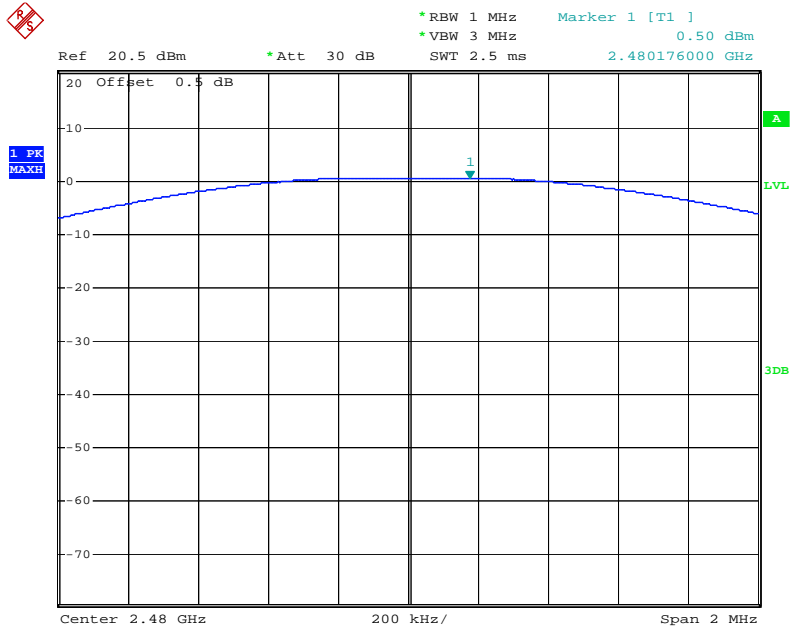

### Π/4-DQPSK Mode

### Low channel

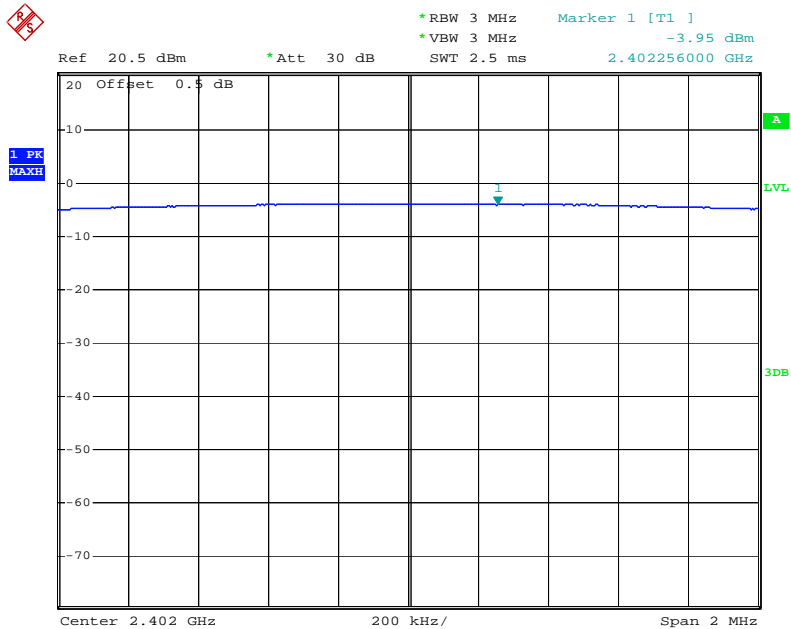

### Middle channel

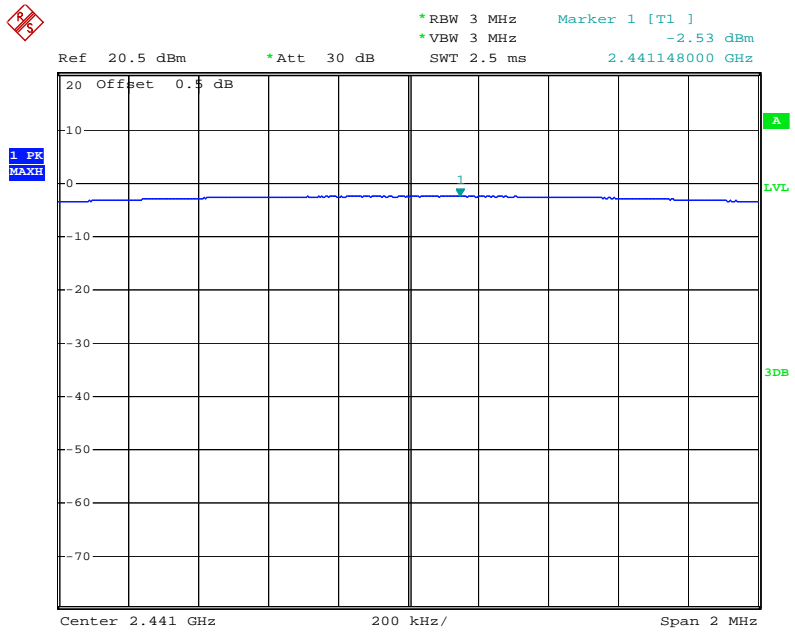

### High channel

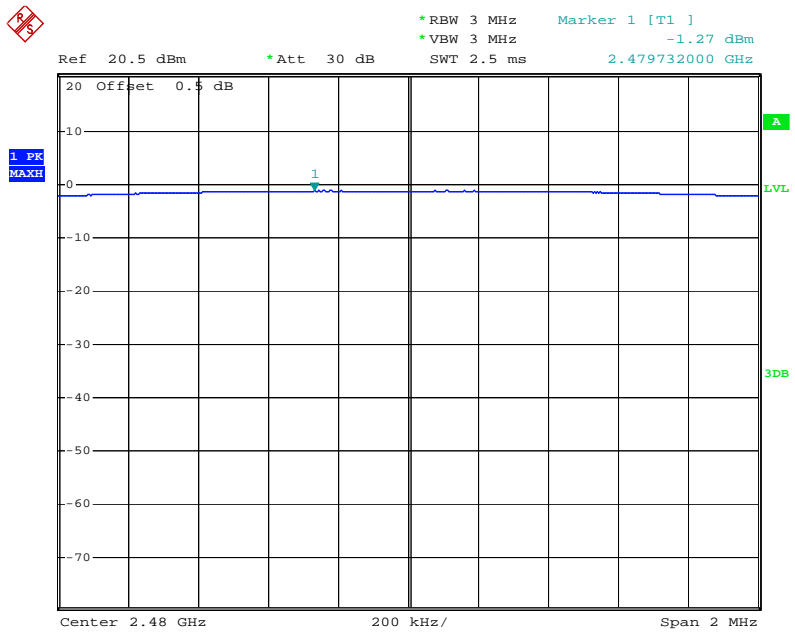

8DPSK Mode

Low channel

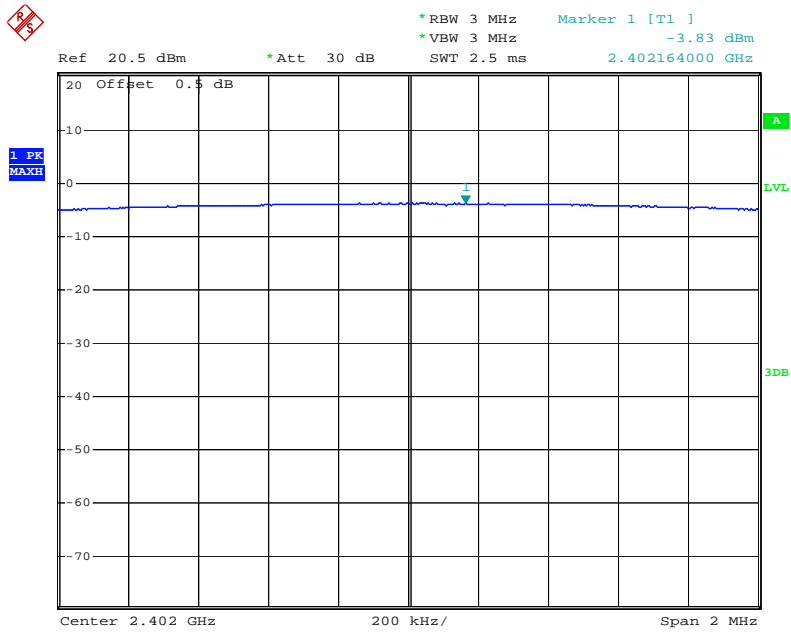

Middle channel

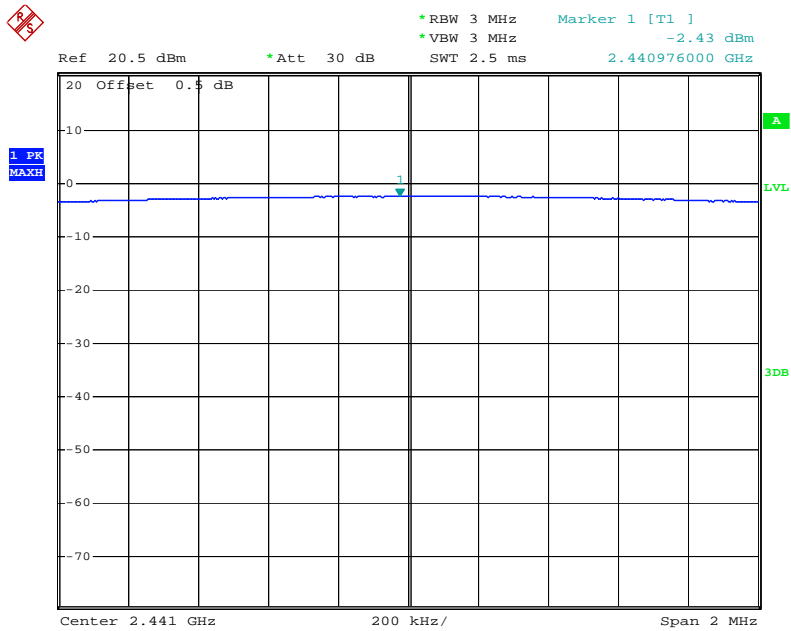



### High channel

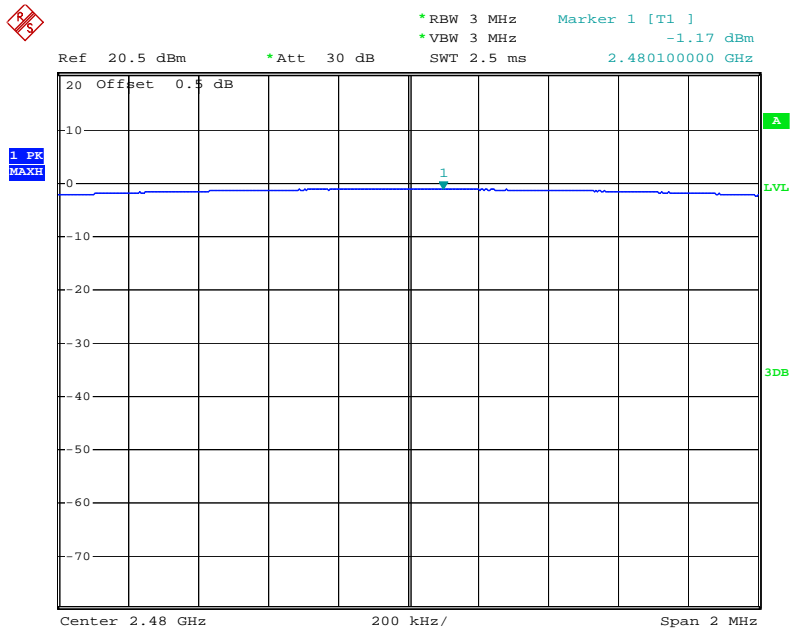

## 10. RADIATED EMISSION TEST

### 10.1. Block Diagram of Test Setup

Radiated Emission Test Set-Up

Frequency range 9KHz – 30MHz

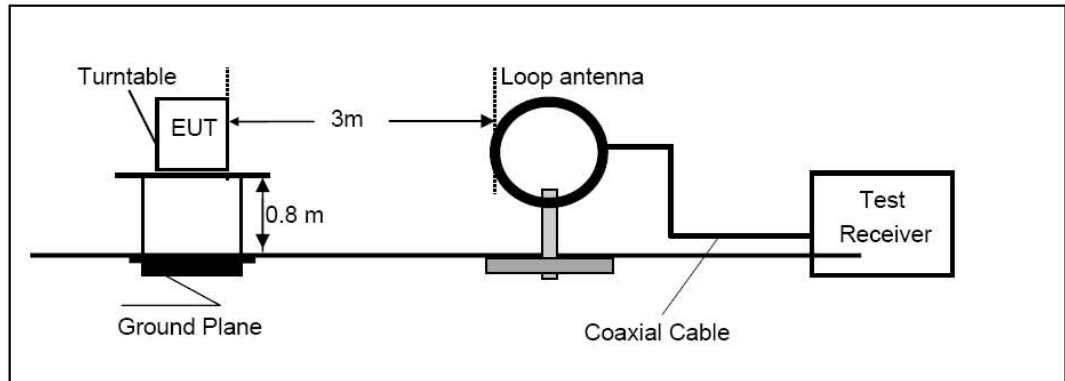

Frequency range 30MHz – 1000MHz

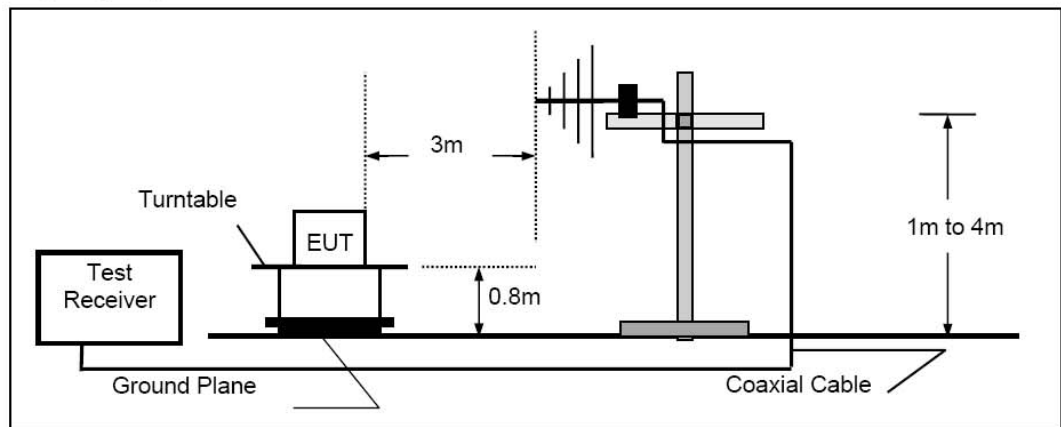

Frequency range above 1GHz-25GHz

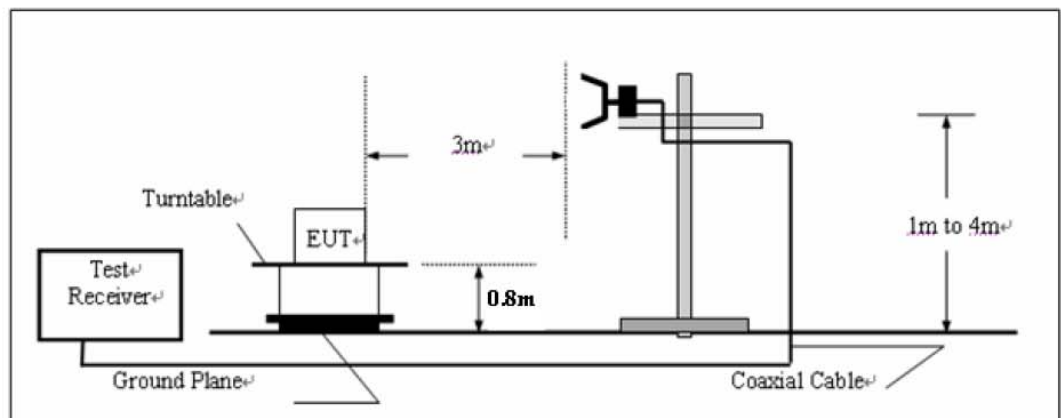

### 10.2.The Limit For Section 15.247(d)

Section 15.247(d): In any 100 kHz bandwidth outside the frequency band in which the spread spectrum or digitally modulated intentional radiator is operating, the radio frequency power that is produced by the intentional radiator shall be at least 20 dB below that in the 100 kHz bandwidth within the band that contains the highest level of the desired power, based on either an RF conducted or a radiated measurement, provided the transmitter demonstrates compliance with the peak conducted power limits. If the transmitter complies with the conducted power limits based on the use of RMS averaging over a time interval, as permitted under paragraph (b)(3) of this section, the attenuation required under this paragraph shall be 30 dB instead of 20 dB. Attenuation below the general limits specified in Section 15.209(a) is not required. In addition, radiated emissions which fall in the restricted bands, as defined in Section 15.205(a), must also comply with the radiated emission limits specified in Section 15.209(a).

### 10.3.Restricted bands of operation

#### 10.3.1.FCC Part 15.205 Restricted bands of operation

(a) Except as shown in paragraph (d) of this section, Only spurious emissions are permitted in any of the frequency bands listed below:

MHz	MHz	MHz	GHz
0.090-0.110	16.42-16.423	399.9-410	4.5-5.15
<sup>1</sup> 0.495-0.505	16.69475-16.69525	608-614	5.35-5.46
2.1735-2.1905	16.80425-16.80475	960-1240	7.25-7.75
4.125-4.128	25.5-25.67	1300-1427	8.025-8.5
4.17725-4.17775	37.5-38.25	1435-1626.5	9.0-9.2
4.20725-4.20775	73-74.6	1645.5-1646.5	9.3-9.5
6.215-6.218	74.8-75.2	1660-1710	10.6-12.7
6.26775-6.26825	108-121.94	1718.8-1722.2	13.25-13.4
6.31175-6.31225	123-138	2200-2300	14.47-14.5
8.291-8.294	149.9-150.05	2310-2390	15.35-16.2
8.362-8.366	156.52475-156.52525	2483.5-2500	17.7-21.4
8.37625-8.38675	156.7-156.9	2690-2900	22.01-23.12
8.41425-8.41475	162.0125-167.17	3260-3267	23.6-24.0
12.29-12.293	167.72-173.2	3332-3339	31.2-31.8
12.51975-12.52025	240-285	3345.8-3358	36.43-36.5
12.57675-12.57725	322-335.4	3600-4400	( <sup>2</sup> )
13.36-13.41			

<sup>1</sup>Until February 1, 1999, this restricted band shall be 0.490-0.510

<sup>2</sup>Above 38.6

(b) Except as provided in paragraphs (d) and (e), the field strength of emission appearing within these frequency bands shall not exceed the limits shown in Section 15.209. At frequencies equal to or less than 1000MHz, Compliance with the limits in Section 15.209 shall be demonstrated using measurement instrumentation employing a CISPR quasi-peak detector. Above 1000MHz, compliance with the emission limits in Section 15.209 shall be demonstrated based on the average value of the measured emissions. The provisions in Section 15.35 apply to these measurements.

#### 10.4. Configuration of EUT on Measurement

The equipment is installed on Radiated Emission Measurement to meet the commission requirements and operating regulations in a manner which tends to maximize its emission characteristics in normal application.

#### 10.5. Test Procedure

The EUT and its simulators are placed on a turntable, which is 0.8 meter high above ground. The turntable can rotate 360 degrees to determine the position of the maximum emission level. EUT is set 3.0 meters away from the receiving antenna, which is mounted on an antenna tower. The antenna can be moved up and down between 1.0 meter and 4 meters to find out the maximum emission level. Broadband antenna (calibrated bilog antenna) is used as receiving antenna. Both horizontal and vertical polarizations of the antenna are set on measurement. In order to find the maximum emission levels, all of the interface cables must be manipulated according to ANSI C63.4: 2009 on radiated emission measurement. The EUT was tested in 3 orthogonal planes.

During the radiated emission test, the spectrum analyzer was set with the following configurations:

1. The resolution bandwidth and video bandwidth of test receiver/spectrum analyzer is 120kHz for Quasi-peak at frequency below 1GHz.
2. The resolution bandwidth of test receiver/spectrum analyzer is 1MHz and video bandwidth is 3MHz for peak measurement with peak detector at frequency above 1GHz.
3. The resolution bandwidth of test receiver/spectrum analyzer is 1MHz and video bandwidth is 10Hz for Average measurement with peak detection at frequency above 1GHz.
4. All modes of operation were investigated and the worst-case emissions are reported.

#### 10.6. The Field Strength of Radiation Emission Measurement Results

**Note: 1. We tested GFSK mode,  $\pi/4$ -DQPSK Mode & 8QPSK mode and recorded the worst case data (GFSK mode) for all test mode.**

**2. The test frequency is from 30MHz to 25GHz, The 18-25GHz emissions are not reported, because the levels are too low against the limit.**

## Below 1GHz

**ACCURATE TECHNOLOGY CO., LTD.**

 F1,Bldg,A,Changyuan New Material Port Keyuan Rd,  
 Science & Industry Park,Nanshan Shenzhen,P.R.China

Site: 1# Chamber

Tel:+86-0755-26503290

Fax:+86-0755-26503396

Job No.: WCARRY #52

Standard: FCC Class B 3M Radiated

Test item: Radiation Test

Temp.( C)/Hum.(%) 25 C / 55 %

EUT: Suitcase Bluetooth Turntable

Mode: TX(2402MHz)

Model: CS-14001

Manufacturer: Jiayinking

Polarization: Horizontal

Power Source: AC 120V/60Hz

Date: 2014/09/26

Time: 18:33:13

Engineer Signature: Carry

Distance: 3m

Note: Report NO.:ATE20141861

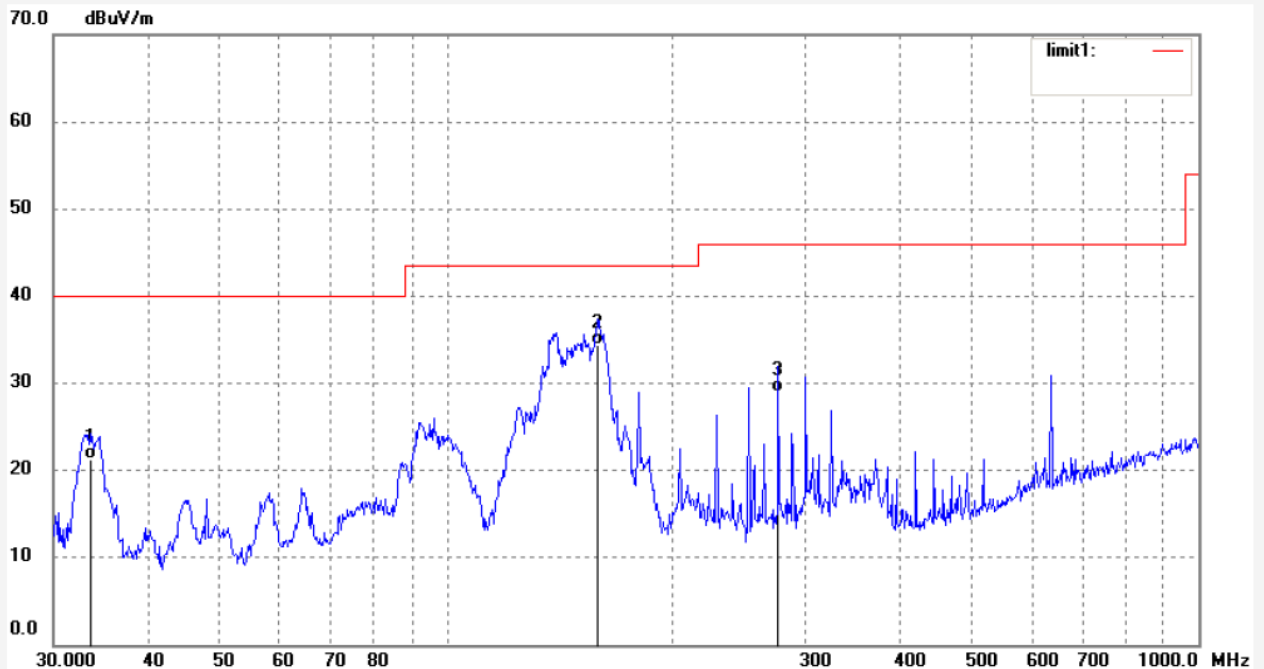

No.	Freq. (MHz)	Reading (dBuV/m)	Factor (dB)	Result (dBuV/m)	Limit (dBuV/m)	Margin (dB)	Detector	Height (cm)	Degree (deg.)	Remark
1	33.5623	38.62	-17.30	21.32	40.00	-18.68	QP			
2	158.6676	57.41	-23.00	34.41	43.50	-9.09	QP			
3	276.1235	47.51	-18.49	29.02	46.00	-16.98	QP			

Job No.: WCARRY #53

Standard: FCC Class B 3M Radiated

Test item: Radiation Test

Temp.( C)/Hum.(%) 25 C / 55 %

EUT: Suitcase Bluetooth Turntable

Mode: TX(2402MHz)

Model: CS-14001

Manufacturer: Jiayingking

Polarization: Vertical

Power Source: AC 120V/60Hz

Date: 2014/09/26

Time: 18:34:21

Engineer Signature: Carry

Distance: 3m

Note: Report NO.:ATE20141861

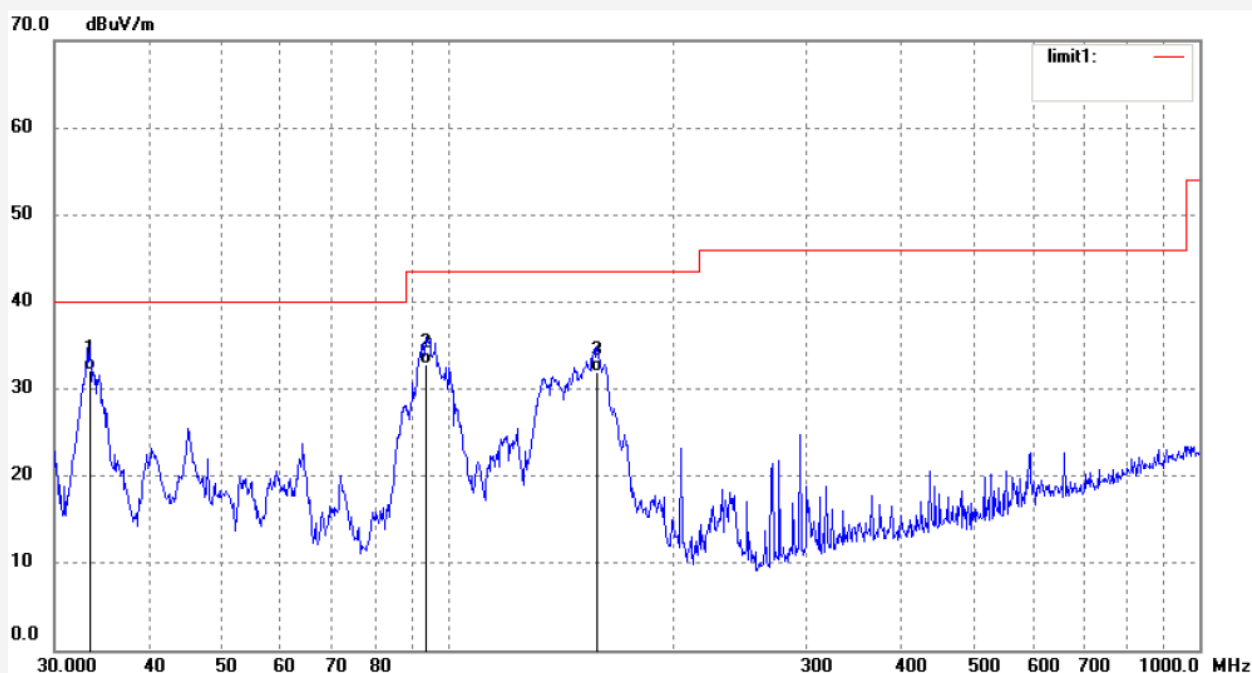

No.	Freq. (MHz)	Reading (dBuV/m)	Factor (dB)	Result (dBuV/m)	Limit (dBuV/m)	Margin (dB)	Detector	Height (cm)	Degree (deg.)	Remark
1	33.4449	49.41	-17.28	32.13	40.00	-7.87	QP			
2	93.4402	54.69	-21.80	32.89	43.50	-10.61	QP			
3	158.1123	55.00	-23.05	31.95	43.50	-11.55	QP			

Job No.: WCARRY #55	Polarization: Horizontal
Standard: FCC Class B 3M Radiated	Power Source: AC 120V/60Hz
Test item: Radiation Test	Date: 2014/09/26
Temp.( C)/Hum.(%) 25 C / 55 %	Time: 18:36:15
EUT: Suitcase Bluetooth Turntable	Engineer Signature: Carry
Mode: TX(2441MHz)	Distance: 3m
Model: CS-14001	
Manufacturer: Jiayinking	

Note: Report NO.:ATE20141861

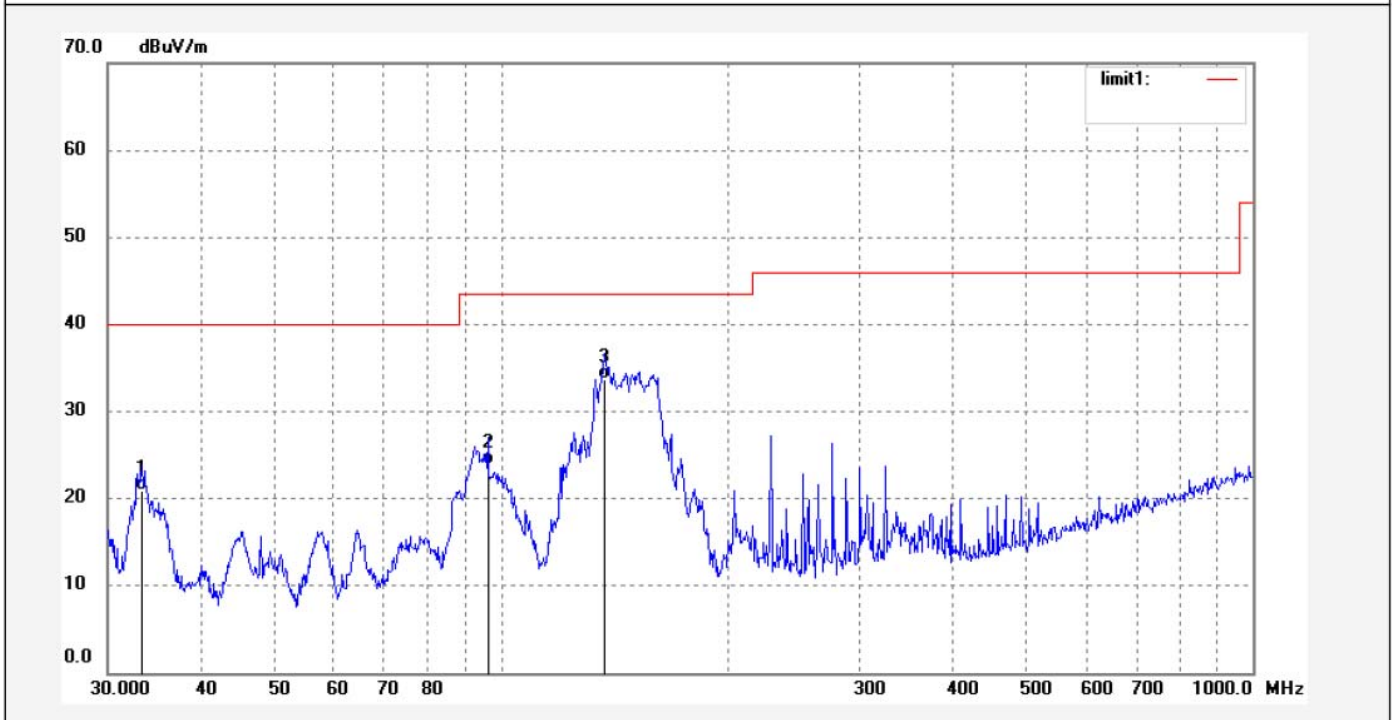

No.	Freq. (MHz)	Reading (dBuV/m)	Factor (dB)	Result (dBuV/m)	Limit (dBuV/m)	Margin (dB)	Detector	Height (cm)	Degree (deg.)	Remark
1	33.3279	38.24	-17.27	20.97	40.00	-19.03	QP			
2	96.0986	45.99	-22.03	23.96	43.50	-19.54	QP			
3	137.4202	56.99	-23.37	33.62	43.50	-9.88	QP			

Job No.: WCARRY #54

Standard: FCC Class B 3M Radiated

Test item: Radiation Test

Temp.( C)/Hum.(%) 25 C / 55 %

EUT: Suitcase Bluetooth Turntable

Mode: TX(2441MHz)

Model: CS-14001

Manufacturer: Jiayingking

Polarization: Vertical

Power Source: AC 120V/60Hz

Date: 2014/09/26

Time: 18:35:11

Engineer Signature: Carry

Distance: 3m

Note: Report NO.:ATE20141861

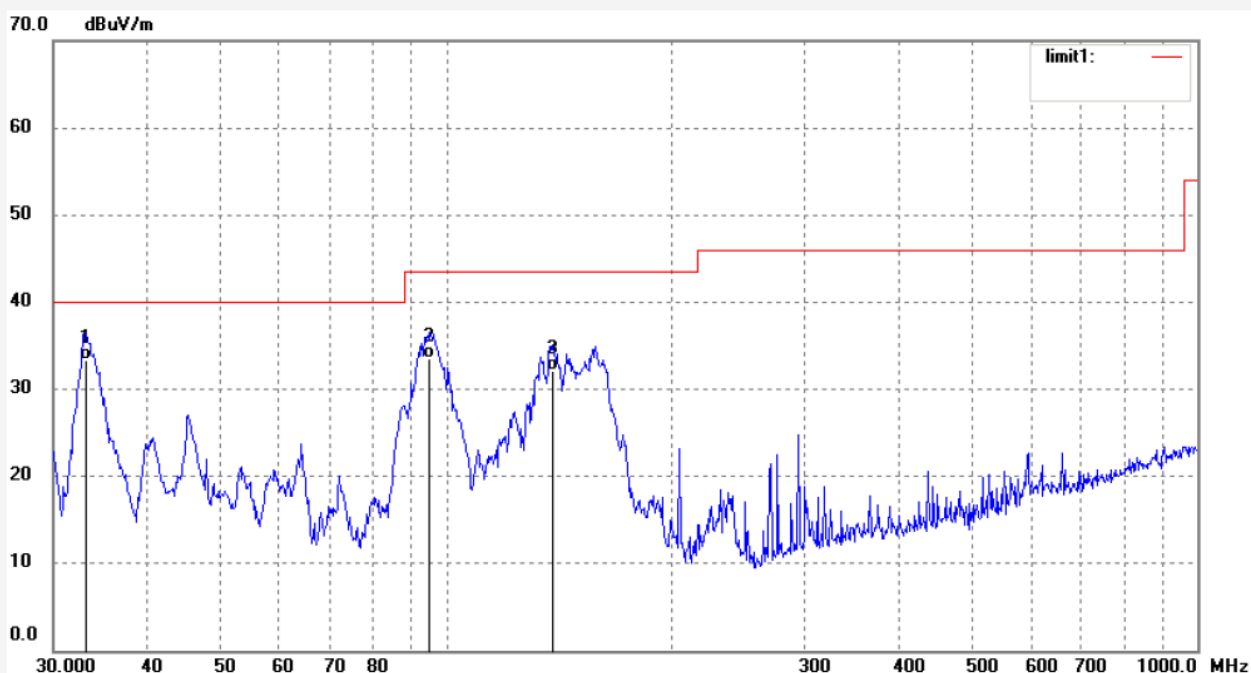

No.	Freq. (MHz)	Reading (dBuV/m)	Factor (dB)	Result (dBuV/m)	Limit (dBuV/m)	Margin (dB)	Detector	Height (cm)	Degree (deg.)	Remark
1	33.2112	50.66	-17.25	33.41	40.00	-6.59	QP			
2	95.0930	55.40	-21.86	33.54	43.50	-9.96	QP			
3	138.3873	55.48	-23.41	32.07	43.50	-11.43	QP			



Job No.: WCARRY #56

Standard: FCC Class B 3M Radiated

Test item: Radiation Test

Temp.( C)/Hum.(%) 25 C / 55 %

EUT: Suitcase Bluetooth Turntable

Mode: TX(2480MHz)

Model: CS-14001

Manufacturer: Jiayinking

Polarization: Horizontal

Power Source: AC 120V/60Hz

Date: 2014/09/26

Time: 18:36:56

Engineer Signature: Carry

Distance: 3m

Note: Report NO.:ATE20141861

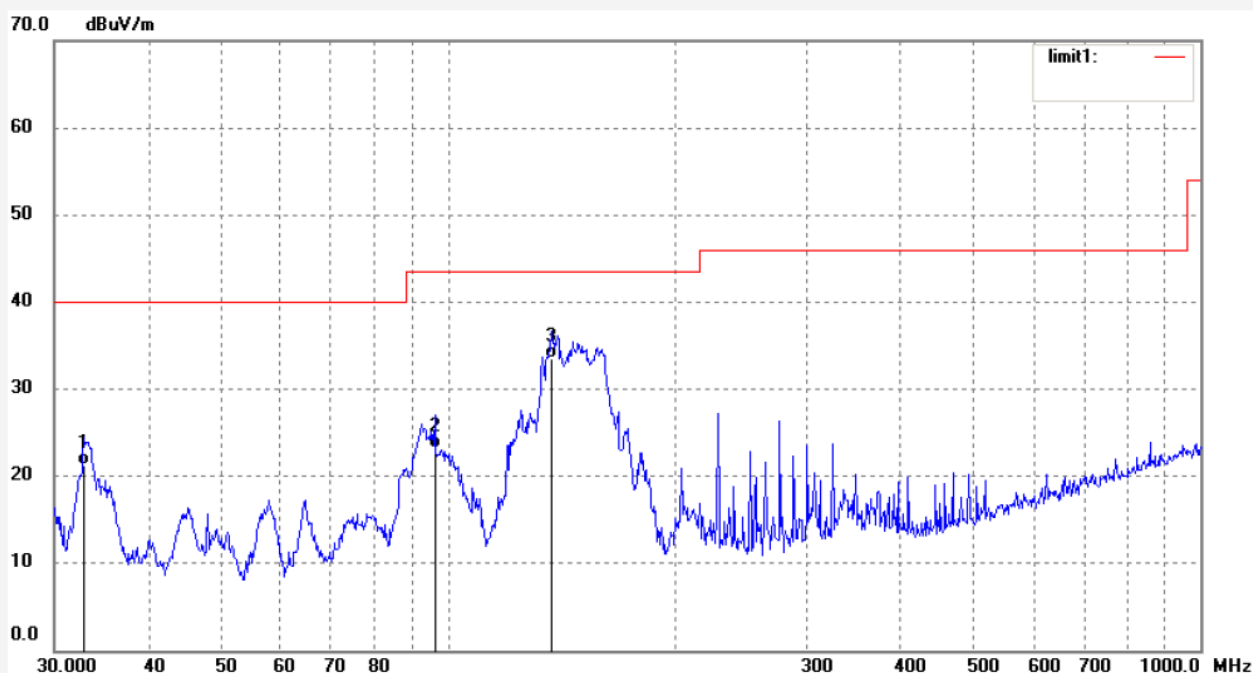

No.	Freq. (MHz)	Reading (dBuV/m)	Factor (dB)	Result (dBuV/m)	Limit (dBuV/m)	Margin (dB)	Detector	Height (cm)	Degree (deg.)	Remark
1	32.8637	38.52	-17.21	21.31	40.00	-18.69	QP			
2	96.0986	45.28	-22.03	23.25	43.50	-20.25	QP			
3	137.4202	56.87	-23.37	33.50	43.50	-10.00	QP			

Job No.: WCARRY #57

Standard: FCC Class B 3M Radiated

Test item: Radiation Test

Temp.( C)/Hum.(%) 25 C / 55 %

EUT: Suitcase Bluetooth Turntable

Mode: TX(2480MHz)

Model: CS-14001

Manufacturer: Jiayingking

Polarization: Vertical

Power Source: AC 120V/60Hz

Date: 2014/09/26

Time: 18:39:28

Engineer Signature: Carry

Distance: 3m

Note: Report NO.:ATE20141861

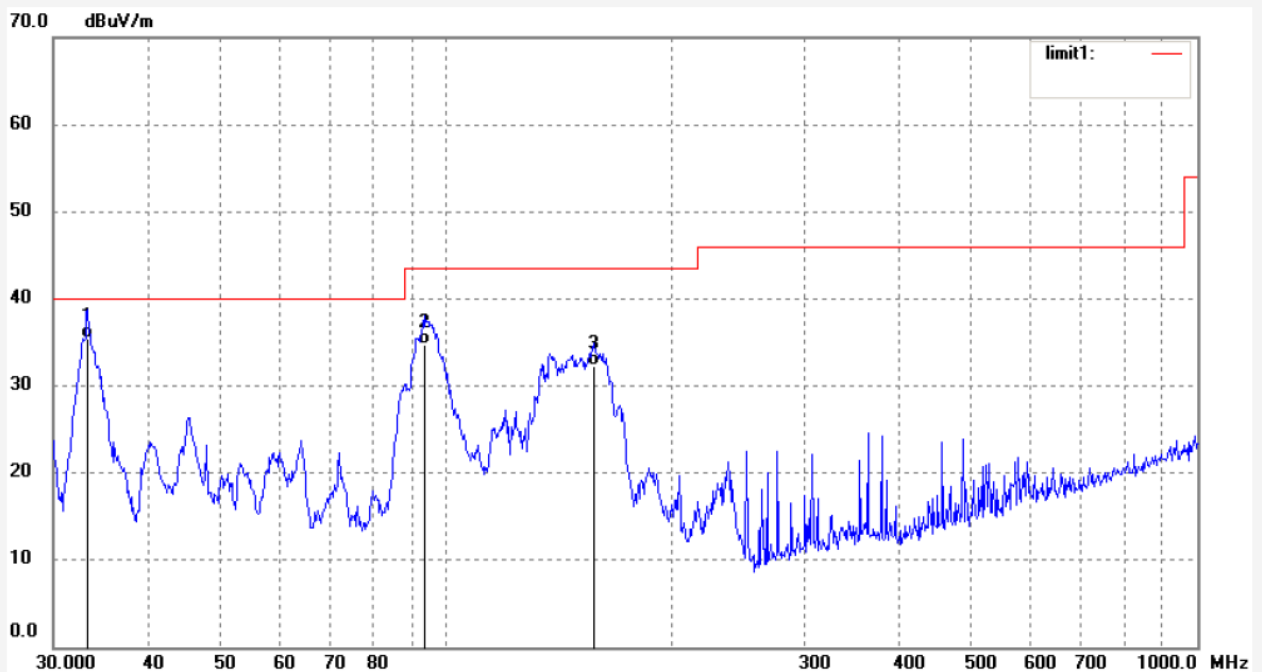

No.	Freq. (MHz)	Reading (dBuV/m)	Factor (dB)	Result (dBuV/m)	Limit (dBuV/m)	Margin (dB)	Detector	Height (cm)	Degree (deg.)	Remark
1	33.3279	52.63	-17.27	35.36	40.00	-4.64	QP			
2	93.4402	56.58	-21.80	34.78	43.50	-8.72	QP			
3	157.0074	55.55	-23.18	32.37	43.50	-11.13	QP			

Above 1GHz



**ACCURATE TECHNOLOGY CO., LTD.**

F1,Bldg,A,Changyuan New Material Port Keyuan Rd,  
Science & Industry Park,Nanshan Shenzhen,P.R.China

Site: 1# Chamber

Tel:+86-0755-26503290

Fax:+86-0755-26503396

Job No.: alen #3483	Polarization: Horizontal
Standard: FCC 15.247 3M Radiated	Power Source: AC 120V/60Hz
Test item: Radiation Test	Date: 2014/09/25
Temp.( C)/Hum.(%) 25 C / 55 %	Time: 8/36/36
EUT: Suitcase Bluetooth Turntable	Engineer Signature:
Mode: TX 2402MHz	Distance: 3m
Model: CS-14001	
Manufacturer: Jiayingking	

Note: Report NO.:ATE20141861

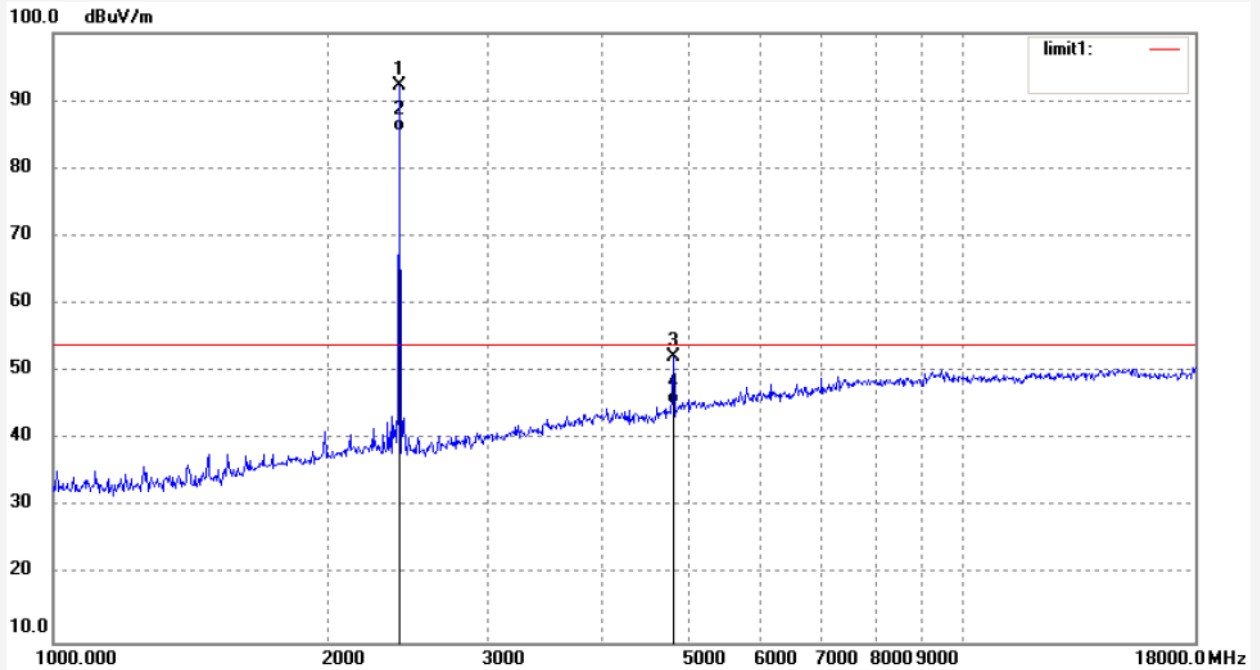

No.	Freq. (MHz)	Reading (dBuV/m)	Factor (dB)	Result (dBuV/m)	Limit (dBuV/m)	Margin (dB)	Detector	Height (cm)	Degree (deg.)	Remark
1	2402.053	98.94	-6.76	92.18			peak			
2	2402.053	92.21	-6.76	85.45			Peak			
3	4804.110	53.75	-1.59	52.16	74.00	-21.84	peak			
4	4804.110	46.75	-1.59	45.16	54.00	-8.84	Peak			

Note: Average measurement with peak detection at No.2&4

Job No.: alen #3484

Standard: FCC 15.247 3M Radiated

Test item: Radiation Test

Temp.( C)/Hum.(%) 25 C / 55 %

EUT: Suitcase Bluetooth Turntable

Mode: TX 2402MHz

Model: CS-14001

Manufacturer: Jiayingking

Polarization: Vertical

Power Source: AC 120V/60Hz

Date: 2014/09/25

Time: 8/38/40

Engineer Signature:

Distance: 3m

Note: Report NO.:ATE20141861

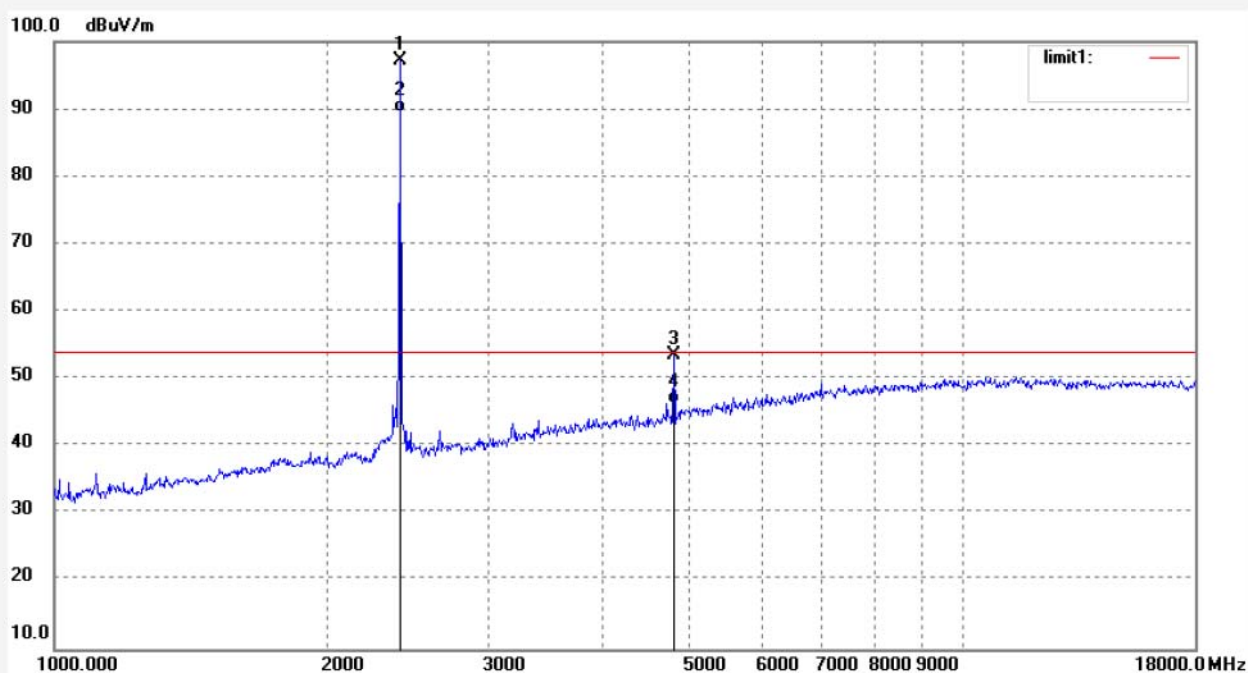

No.	Freq. (MHz)	Reading (dBuV/m)	Factor (dB)	Result (dBuV/m)	Limit (dBuV/m)	Margin (dB)	Detector	Height (cm)	Degree (deg.)	Remark
1	2402.053	103.99	-6.76	97.23			peak			
2	2402.053	96.28	-6.76	89.52			Peak			
3	4804.110	55.04	-1.59	53.45	74.00	-20.55	peak			
4	4804.110	47.83	-1.59	46.24	54.00	-7.76	Peak			

Note: Average measurement with peak detection at No.2&amp;4



**ACCURATE TECHNOLOGY CO., LTD.**

F1,Bldg,A,Changyuan New Material Port Keyuan Rd,  
Science & Industry Park,Nanshan Shenzhen,P.R.China

Site: 1# Chamber

Tel:+86-0755-26503290

Fax:+86-0755-26503396

Job No.: alen #3486	Polarization: Horizontal
Standard: FCC 15.247 3M Radiated	Power Source: AC 120V/60Hz
Test item: Radiation Test	Date: 2014/09/25
Temp.( C)/Hum.(%) 25 C / 55 %	Time: 8/43/07
EUT: Suitcase Bluetooth Turntable	Engineer Signature:
Mode: TX 2441MHz	Distance: 3m
Model: CS-14001	
Manufacturer: Jiayingking	

Note: Report NO.:ATE20141861

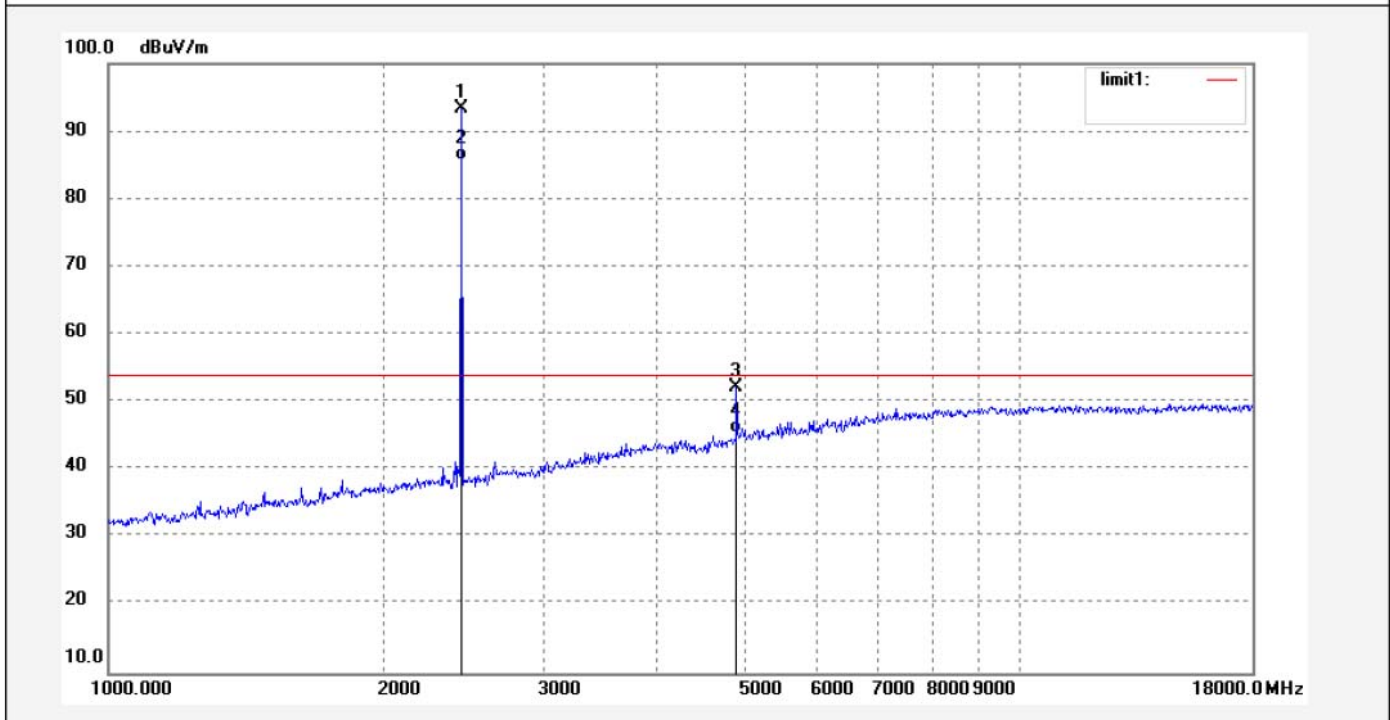

No.	Freq. (MHz)	Reading (dBuV/m)	Factor (dB)	Result (dBuV/m)	Limit (dBuV/m)	Margin (dB)	Detector	Height (cm)	Degree (deg.)	Remark
1	2441.051	99.97	-6.64	93.33			peak			
2	2441.051	92.45	-6.64	85.81			Peak			
3	4882.151	53.53	-1.33	52.20	74.00	-21.80	peak			
4	4882.151	46.69	-1.33	45.36	54.00	-8.64	Peak			

Note: Average measurement with peak detection at No.2&4

Job No.: alen #3485

Standard: FCC 15.247 3M Radiated

Test item: Radiation Test

Temp.( C)/Hum.(%) 25 C / 55 %

EUT: Suitcase Bluetooth Turntable

Mode: TX 2441MHz

Model: CS-14001

Manufacturer: Jiayingking

Polarization: Vertical

Power Source: AC 120V/60Hz

Date: 2014/09/25

Time: 8/40/57

Engineer Signature:

Distance: 3m

Note: Report NO.:ATE20141861

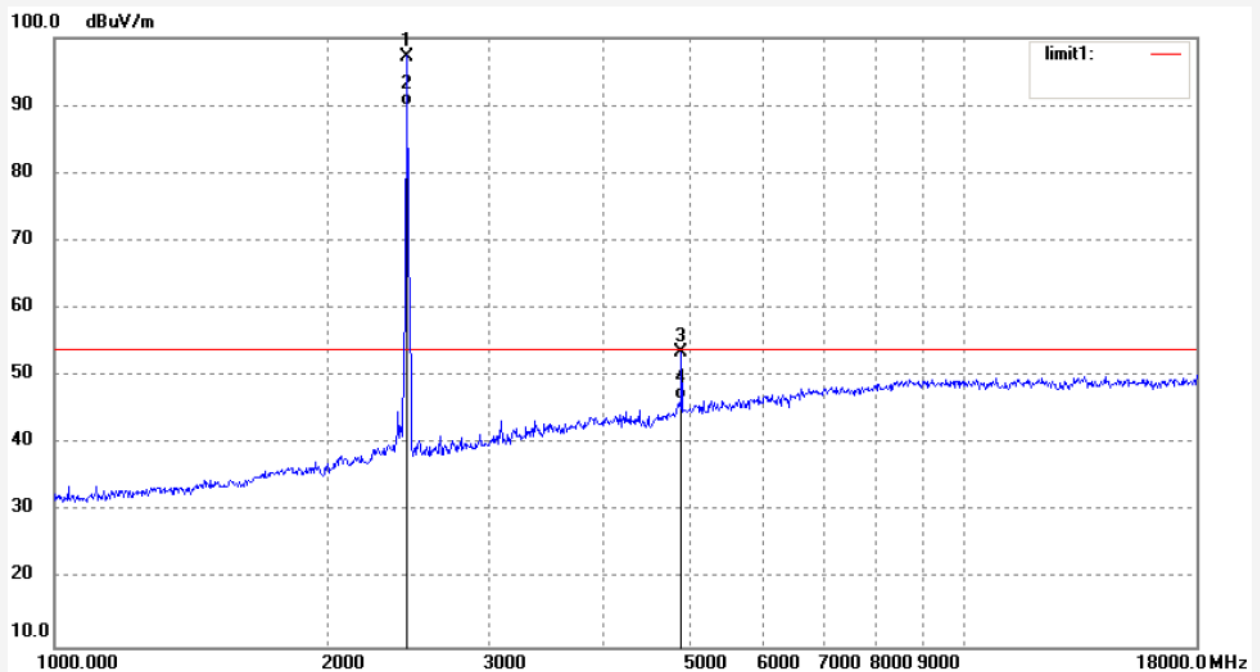

No.	Freq. (MHz)	Reading (dBuV/m)	Factor (dB)	Result (dBuV/m)	Limit (dBuV/m)	Margin (dB)	Detector	Height (cm)	Degree (deg.)	Remark
1	2441.051	103.94	-6.64	97.30			peak			
2	2441.051	96.54	-6.64	89.90			Peak			
3	4882.151	54.97	-1.33	53.64	74.00	-20.36	peak			
4	4882.151	47.80	-1.33	46.47	54.00	-7.53	Peak			

Note: Average measurement with peak detection at No.2&amp;4

Job No.: alen #3487	Polarization: Horizontal
Standard: FCC 15.247 3M Radiated	Power Source: AC 120V/60Hz
Test item: Radiation Test	Date: 2014/09/25
Temp.( C)/Hum.(%) 25 C / 55 %	Time: 8/44/55
EUT: Suitcase Bluetooth Turntable	Engineer Signature:
Mode: TX 2480MHz	Distance: 3m
Model: CS-14001	
Manufacturer: Jiayingking	

Note: Report NO.:ATE20141861

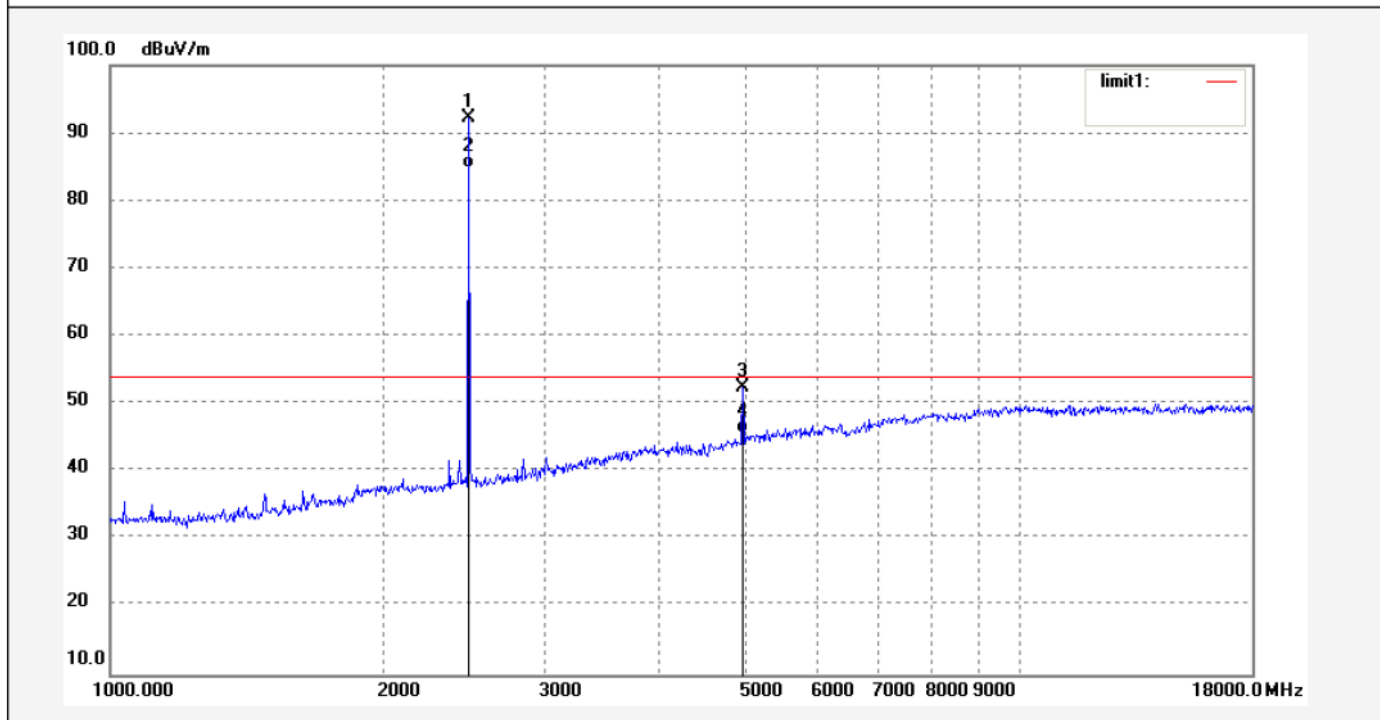

No.	Freq. (MHz)	Reading (dBuV/m)	Factor (dB)	Result (dBuV/m)	Limit (dBuV/m)	Margin (dB)	Detector	Height (cm)	Degree (deg.)	Remark
1	2480.310	98.89	-6.56	92.33			peak			
2	2480.310	91.32	-6.56	84.76			Peak			
3	4960.307	53.64	-1.12	52.52	74.00	-21.48	peak			
4	4960.307	46.78	-1.12	45.66	54.00	-8.34	Peak			

Note: Average measurement with peak detection at No.2&4

Job No.: alen #3488

Standard: FCC 15.247 3M Radiated

Test item: Radiation Test

Temp.( C)/Hum.(%) 25 C / 55 %

EUT: Suitcase Bluetooth Turntable

Mode: TX 2480MHz

Model: CS-14001

Manufacturer: Jiayingking

Polarization: Vertical

Power Source: AC 120V/60Hz

Date: 2014/09/25

Time: 8/47/05

Engineer Signature:

Distance: 3m

Note: Report NO.:ATE20141861

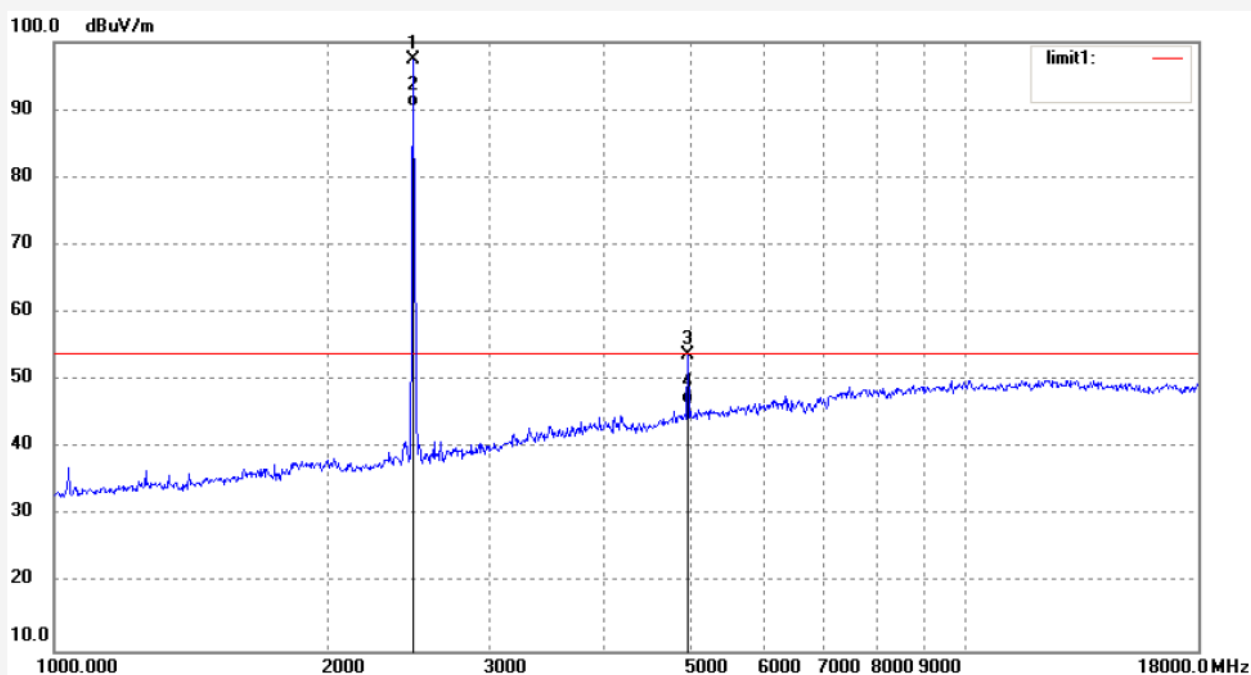

No.	Freq. (MHz)	Reading (dBuV/m)	Factor (dB)	Result (dBuV/m)	Limit (dBuV/m)	Margin (dB)	Detector	Height (cm)	Degree (deg.)	Remark
1	2480.310	104.03	-6.56	97.47			peak			
2	2480.310	96.89	-6.56	90.33			Peak			
3	4960.307	54.79	-1.12	53.67	74.00	-20.33	peak			
4	4960.307	47.74	-1.12	46.62	54.00	-7.38	Peak			

Note: Average measurement with peak detection at No.2&amp;4



## 11. BAND EDGE COMPLIANCE TEST

### 11.1. Block Diagram of Test Setup

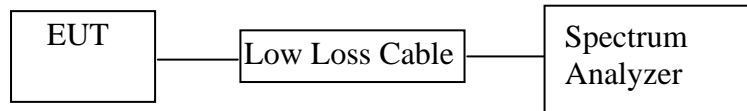

(EUT: Suitcase Bluetooth Turntable)

### 11.2. The Requirement For Section 15.247(d)

Section 15.247(d): In any 100 kHz bandwidth outside the frequency band in which the spread spectrum or digitally modulated intentional radiator is operating, the radio frequency power that is produced by the intentional radiator shall be at least 20 dB below that in the 100 kHz bandwidth within the band that contains the highest level of the desired power, based on either an RF conducted or a radiated measurement, provided the transmitter demonstrates compliance with the peak conducted power limits. If the transmitter complies with the conducted power limits based on the use of RMS averaging over a time interval, as permitted under paragraph (b)(3) of this section, the attenuation required under this paragraph shall be 30 dB instead of 20 dB. Attenuation below the general limits specified in Section 15.209(a) is not required. In addition, radiated emissions which fall in the restricted bands, as defined in Section 15.205(a), must also comply with the radiated emission limits specified in Section 15.209(a).

### 11.3. EUT Configuration on Measurement

The equipment are installed on the emission Measurement to meet the commission requirements and operating regulations in a manner which tends to maximize its emission characteristics in normal application.

### 11.4. Operating Condition of EUT

11.4.1. Setup the EUT and simulator as shown as Section 11.1.

11.4.2. Turn on the power of all equipment.

11.4.3. Let the EUT work in TX (Hopping off, Hopping on) modes measure it. The transmit frequency are 2402-2480MHz. We select 2402MHz, 2480MHz TX frequency to transmit.

## 11.5. Test Procedure

11.5.1. The transmitter output was connected to the spectrum analyzer via a low loss cable.

11.5.2. Set RBW of spectrum analyzer to 100 kHz and VBW to 300 kHz with convenient frequency span including 100 kHz bandwidth from band edge.

11.5.3. The band edges was measured and recorded.

## 11.6. Test Result

Frequency (MHz)	Result of Band Edge (dBc)	Limit of Band Edge (dBc)
GFSK		
2399.880	44.49	> 20dBc
2486.860	48.55	> 20dBc
Π/4-DQPSK Mode		
2399.520	44.06	> 20dBc
2490.400	46.58	> 20dBc
8DPSK		
2398.920	43.27	> 20dBc
2485.300	46.71	> 20dBc

## GFSK

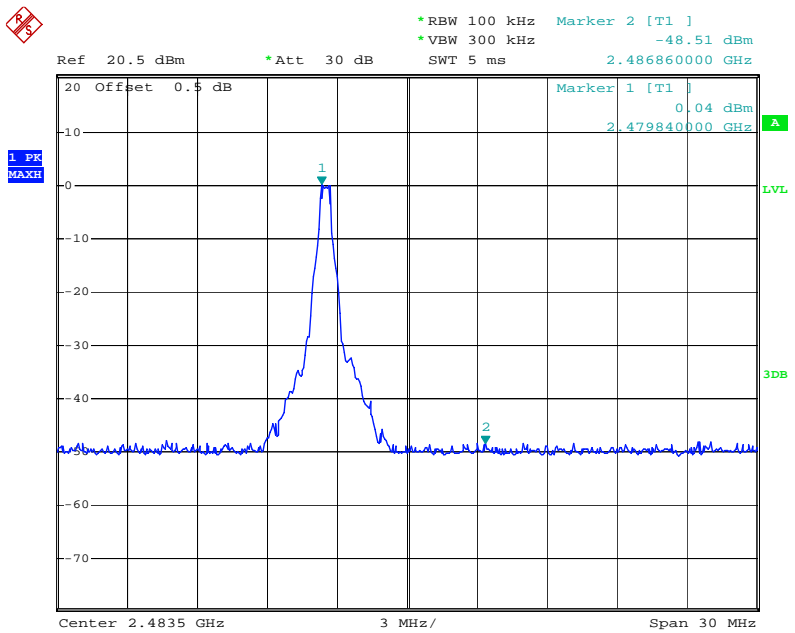
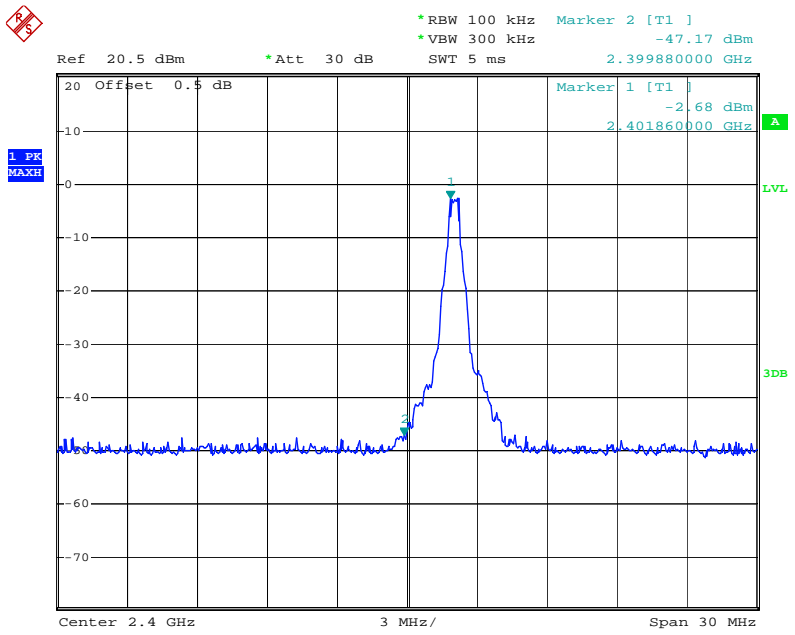

### Π/4-DQPSK Mode

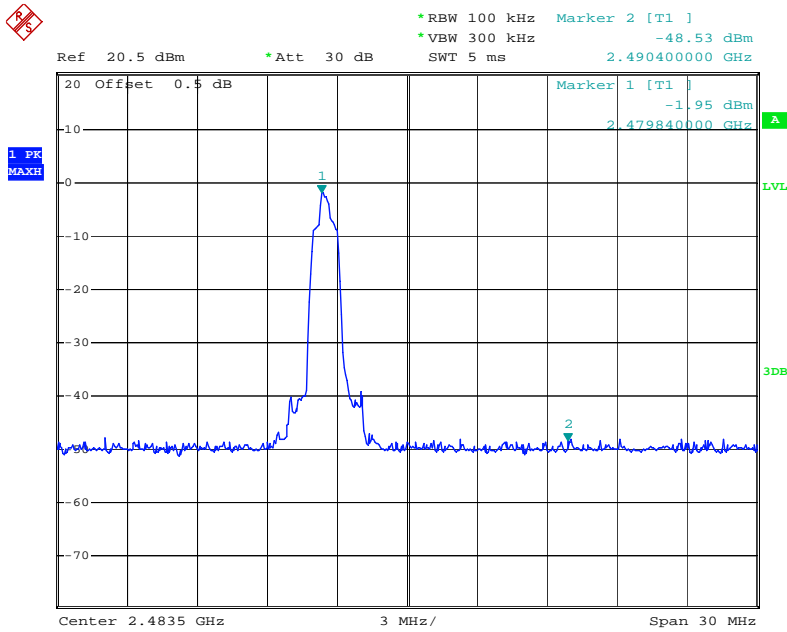
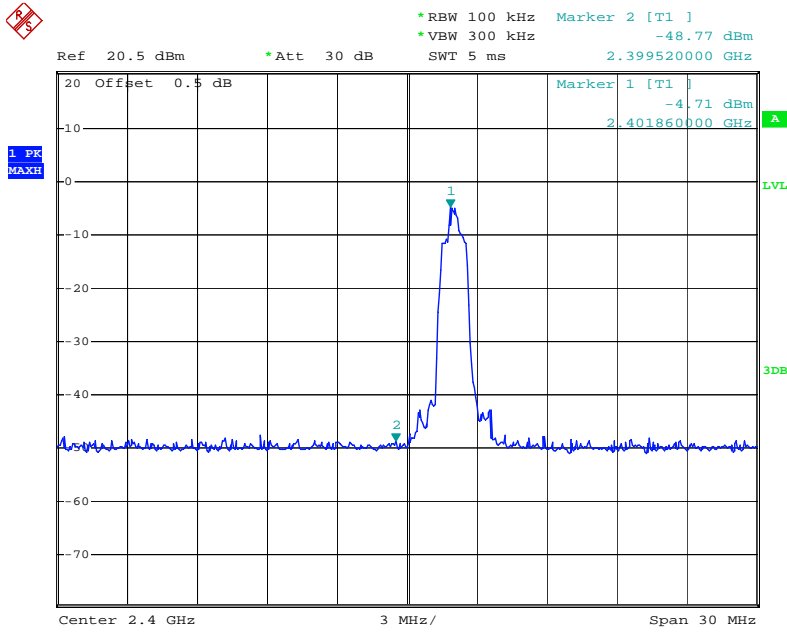

8DPSK

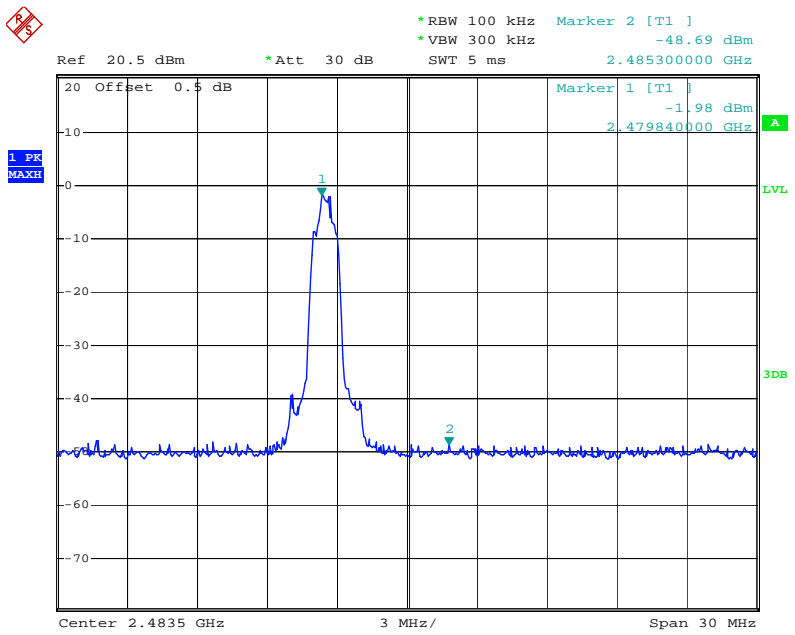
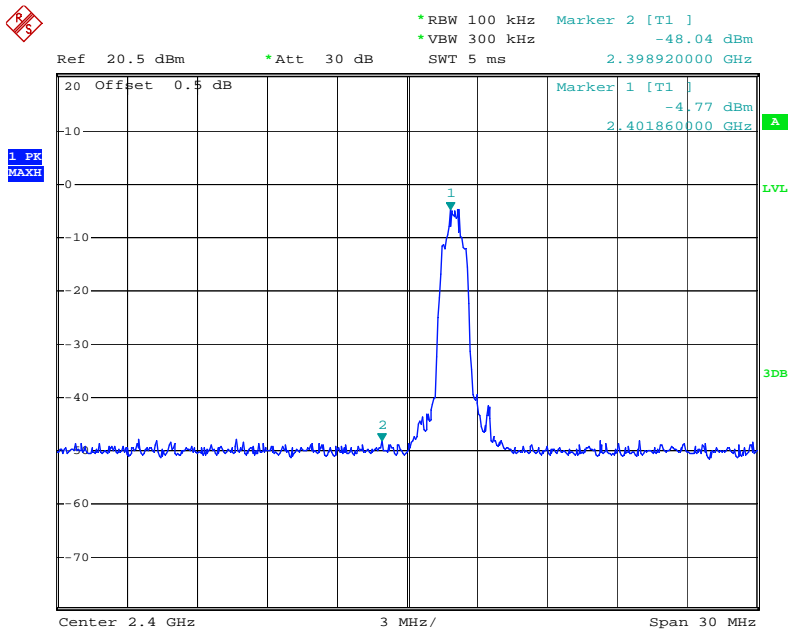

## Radiated Band Edge Result

Note:

1. Emissions attenuated more than 20 dB below the permissible value are not reported.
2. The field strength is calculated by adding the antenna factor, high pass filter loss(if used) and cable loss, and subtracting the amplifier gain(if any)from the measured reading. The basic equation calculation is as follows:

Result = Reading + Corrected Factor

3. Display the measurement of peak values.

Test Procedure:

The EUT and its simulators are placed on a turntable, which is 0.8 meter high above ground. The turntable can rotate 360 degrees to determine the position of the maximum emission level. EUT is set 3.0 meters away from the receiving antenna, which is mounted on an antenna tower. The antenna can be moved up and down between 1.0 meter and 4 meters to find out the maximum emission level. Broadband antenna (calibrated bilog antenna) is used as receiving antenna. Both horizontal and vertical polarizations of the antenna are set on measurement. In order to find the maximum emission levels, all of the interface cables must be manipulated according to ANSI C63.4: 2009 on radiated emission measurement. The EUT was tested in 3 orthogonal planes.

Let the EUT work in TX (Hopping off, Hopping on) modes measure it.

We select 2402MHz, 2480MHz TX frequency to transmit(Hopping off mode).

We select 2402-2480MHz TX frequency to transmit(Hopping on mode).

During the radiated emission test, the spectrum analyzer was set with the following configurations:

- 1.The resolution bandwidth of test receiver/spectrum analyzer is 1MHz and video bandwidth is 3MHz for peak measurement with peak detector at frequency above 1GHz.
- 2.The resolution bandwidth of test receiver/spectrum analyzer is 1MHz and video bandwidth is 10Hz for Average measurement with peak detection at frequency above 1GHz.
- 3.All modes of operation were investigated and the worst-case emissions are reported.

## Non-hopping mode

**ACCURATE TECHNOLOGY CO., LTD.**

 F1,Bldg,A,Changyuan New Material Port Keyuan Rd,  
 Science & Industry Park,Nanshan Shenzhen,P.R.China

Site: 2# Chamber

Tel:+86-0755-26503290

Fax:+86-0755-26503396

Job No.: Ricky #182

Standard: FCC 15C PK

Test item: Radiation Test

Temp.( C)/Hum.(%) 23 C / 49 %

EUT: Suitcase Bluetooth Turntable

Mode: TX 2402MHz(GFSK)

Model: CS-14001

Manufacturer: Jiayinking

Polarization: Horizontal

Power Source: AC 120V/60Hz

Date: 2014/09/25

Time: 12/48/42

Engineer Signature: Ricky

Distance: 3m

Note: Report NO.:ATE20141861

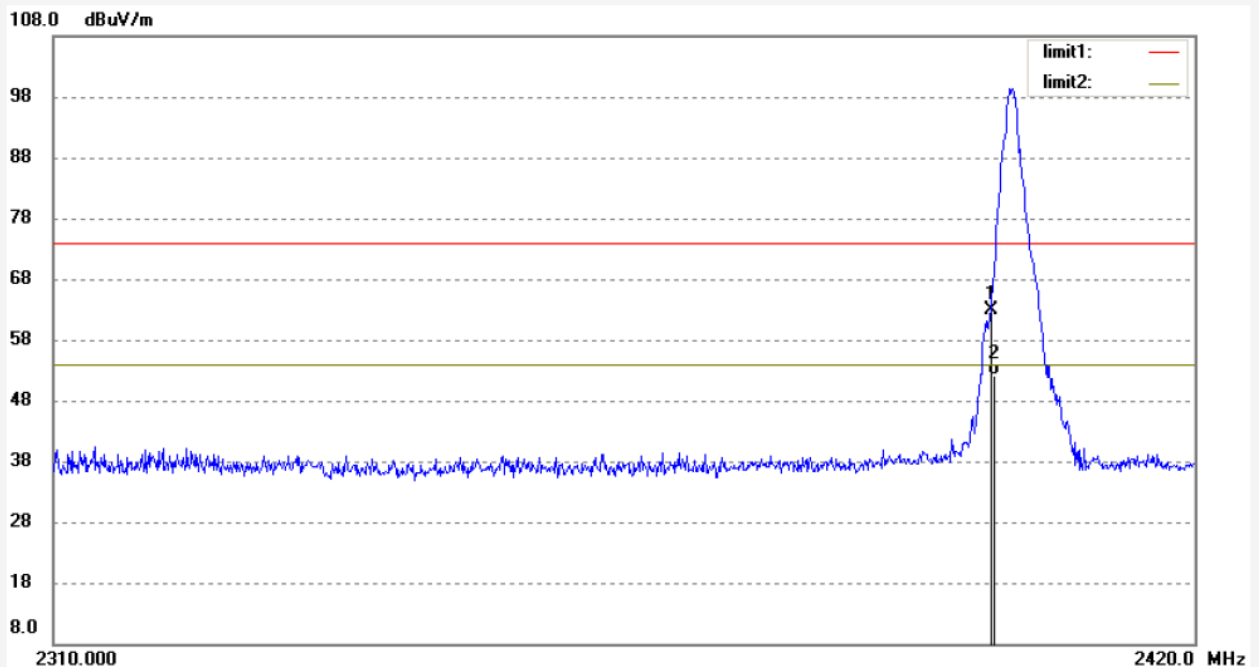

No.	Freq. (MHz)	Reading (dBuV/m)	Factor (dB)	Result (dBuV/m)	Limit (dBuV/m)	Margin (dB)	Detector	Height (cm)	Degree (deg.)	Remark
1	2400.000	70.45	-7.46	62.99	74.00	-11.01	peak			
2	2400.000	59.69	-7.46	52.23	54.00	-1.77	Peak			

Note: Average measurement with peak detection at No.2

Job No.: Ricky #181	Polarization: Vertical
Standard: FCC 15C PK	Power Source: AC 120V/60Hz
Test item: Radiation Test	Date: 2014/09/25
Temp.( C)/Hum.(%) 23 C / 49 %	Time: 12/46/01
EUT: Suitcase Bluetooth Turntable	Engineer Signature: Ricky
Mode: TX 2402MHz(GFSK)	Distance: 3m
Model: CS-14001	
Manufacturer: Jiayingking	

Note: Report NO.:ATE20141861

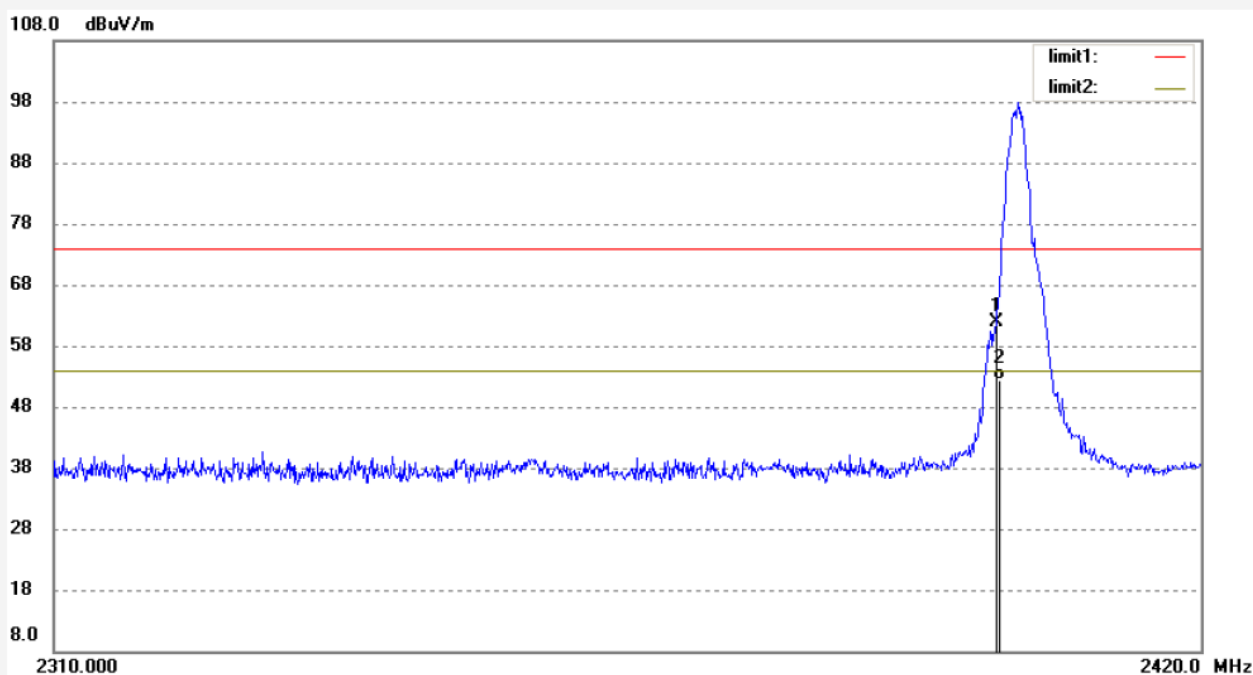

No.	Freq. (MHz)	Reading (dBuV/m)	Factor (dB)	Result (dBuV/m)	Limit (dBuV/m)	Margin (dB)	Detector	Height (cm)	Degree (deg.)	Remark
1	2400.000	69.22	-7.46	61.76	74.00	-12.24	peak			
2	2400.000	59.91	-7.46	52.45	54.00	-1.55	Peak			

Note: Average measurement with peak detection at No.2





**ACCURATE TECHNOLOGY CO., LTD.**

F1,Bldg,A,Changyuan New Material Port Keyuan Rd,  
Science & Industry Park,Nanshan Shenzhen,P.R.China

Site: 2# Chamber

Tel:+86-0755-26503290

Fax:+86-0755-26503396

Job No.: Ricky #183

Standard: FCC 15C PK

Test item: Radiation Test

Temp.( C)/Hum.(%) 23 C / 49 %

EUT: Suitcase Bluetooth Turntable

Mode: TX 2480MHz(GFSK)

Model: CS-14001

Manufacturer: Jiayingking

Polarization: Horizontal

Power Source: AC 120V/60Hz

Date: 2014/09/25

Time: 12/50/11

Engineer Signature: Ricky

Distance: 3m

Note: Report NO.:ATE20141861

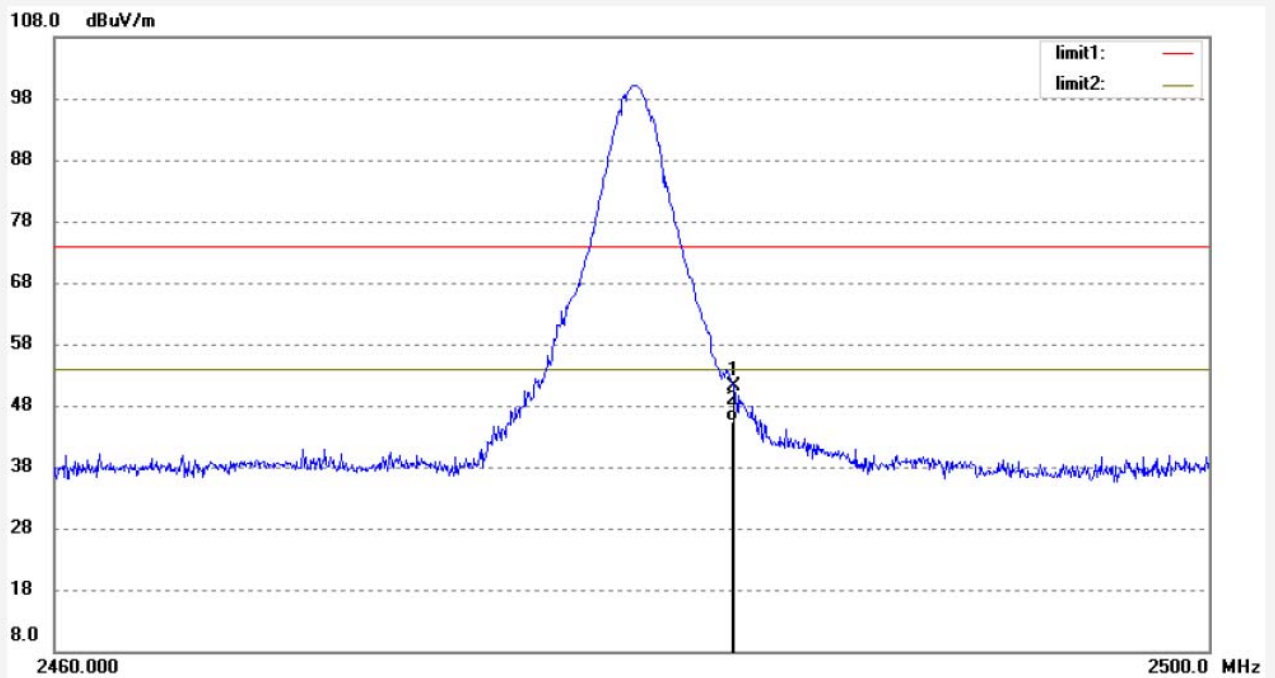

No.	Freq. (MHz)	Reading (dBuV/m)	Factor (dB)	Result (dBuV/m)	Limit (dBuV/m)	Margin (dB)	Detector	Height (cm)	Degree (deg.)	Remark
1	2483.529	58.57	-7.37	51.20	74.00	-22.80	peak			
2	2483.529	52.63	-7.37	45.26	54.00	-8.74	Peak			

Note: Average measurement with peak detection at No.2



**ACCURATE TECHNOLOGY CO., LTD.**

F1,Bldg,A,Changyuan New Material Port Keyuan Rd,  
Science & Industry Park,Nanshan Shenzhen,P.R.China

Site: 2# Chamber

Tel:+86-0755-26503290

Fax:+86-0755-26503396

Job No.: Ricky #184	Polarization: Vertical
Standard: FCC 15C PK	Power Source: AC 120V/60Hz
Test item: Radiation Test	Date: 2014/09/25
Temp.( C)/Hum.(%) 23 C / 49 %	Time: 12/54/15
EUT: Suitcase Bluetooth Turntable	Engineer Signature: Ricky
Mode: TX 2480MHz(GFSK)	Distance: 3m
Model: CS-14001	
Manufacturer: Jiayinking	

Note: Report NO.:ATE20141861

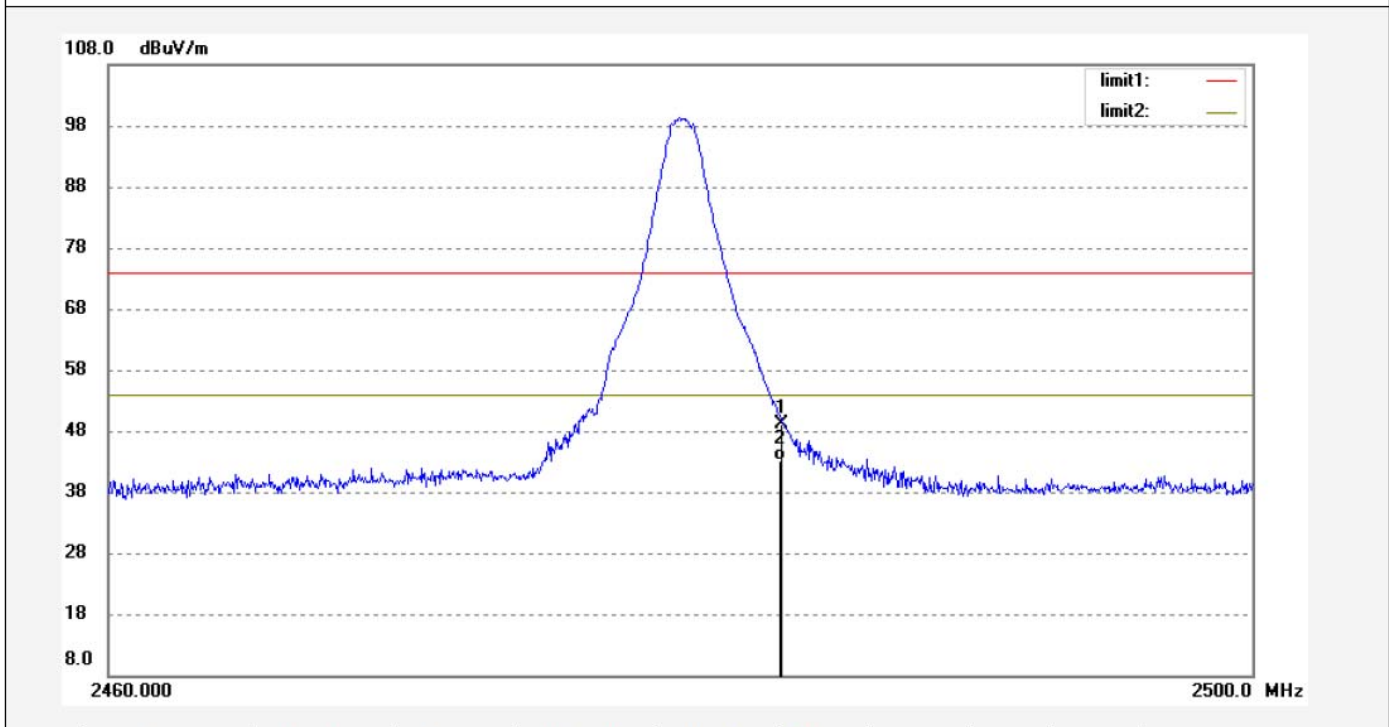

No.	Freq. (MHz)	Reading (dBuV/m)	Factor (dB)	Result (dBuV/m)	Limit (dBuV/m)	Margin (dB)	Detector	Height (cm)	Degree (deg.)	Remark
1	2483.529	56.48	-7.37	49.11	74.00	-24.89	peak			
2	2483.529	50.52	-7.37	43.15	54.00	-10.85	Peak			

Note: Average measurement with peak detection at No.2

Job No.: Ricky #185

Standard: FCC 15C PK

Test item: Radiation Test

Temp.( C)/Hum.(%) 23 C / 49 %

EUT: Suitcase Bluetooth Turntable

Mode: TX 2402MHz(PI/4DQPSK)

Model: CS-14001

Manufacturer: Jiayinking

Polarization: Vertical

Power Source: AC 120V/60Hz

Date: 2014/09/25

Time: 12/56/01

Engineer Signature: Ricky

Distance: 3m

Note: Report NO.:ATE20141861

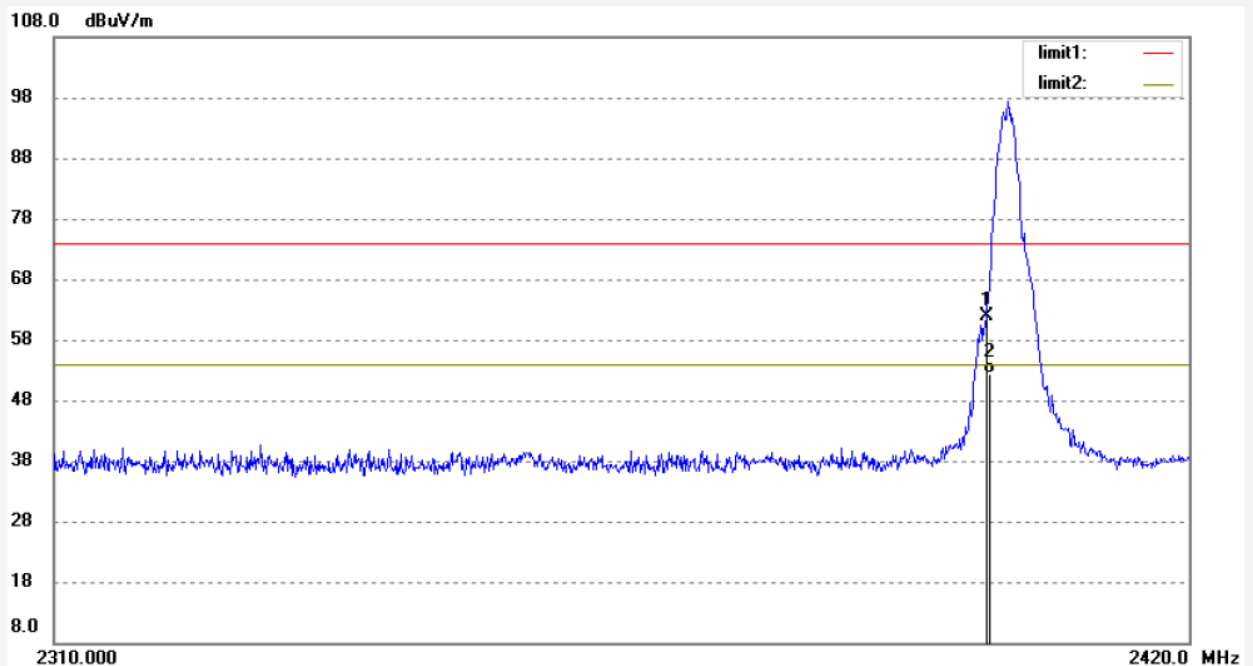

No.	Freq. (MHz)	Reading (dBuV/m)	Factor (dB)	Result (dBuV/m)	Limit (dBuV/m)	Margin (dB)	Detector	Height (cm)	Degree (deg.)	Remark
1	2400.000	69.31	-7.46	61.85	74.00	-12.15	peak			
2	2400.000	59.88	-7.46	52.42	54.00	-1.58	Peak			

Note: Average measurement with peak detection at No.2

Job No.: Ricky #186

Standard: FCC 15C PK

Test item: Radiation Test

Temp.( C)/Hum.(%) 23 C / 49 %

EUT: Suitcase Bluetooth Turntable

Mode: TX 2402MHz(PI/4DQPSK)

Model: CS-14001

Manufacturer: Jiayingking

Polarization: Horizontal

Power Source: AC 120V/60Hz

Date: 2014/09/25

Time: 12/57/18

Engineer Signature: Ricky

Distance: 3m

Note: Report NO.:ATE20141861

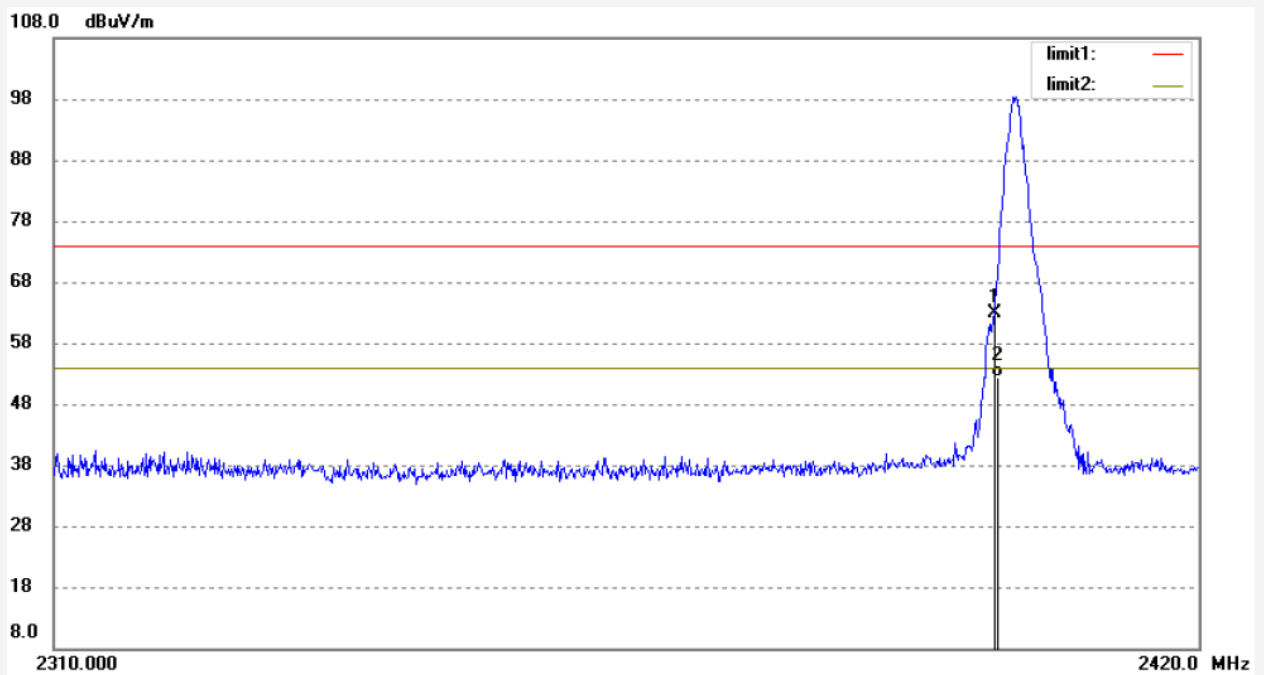

No.	Freq. (MHz)	Reading (dBuV/m)	Factor (dB)	Result (dBuV/m)	Limit (dBuV/m)	Margin (dB)	Detector	Height (cm)	Degree (deg.)	Remark
1	2400.000	70.46	-7.46	63.00	74.00	-11.00	peak			
2	2400.000	59.77	-7.46	52.31	54.00	-1.69	Peak			

Note: Average measurement with peak detection at No.2

Job No.: Ricky #187	Polarization: Horizontal
Standard: FCC 15C PK	Power Source: AC 120V/60Hz
Test item: Radiation Test	Date: 2014/09/25
Temp.( C)/Hum.(%) 23 C / 49 %	Time: 12/59/22
EUT: Suitcase Bluetooth Turntable	Engineer Signature: Ricky
Mode: TX 2480MHz(PI/4DQPSK)	Distance: 3m
Model: CS-14001	
Manufacturer: Jiayingking	

Note: Report NO.:ATE20141861

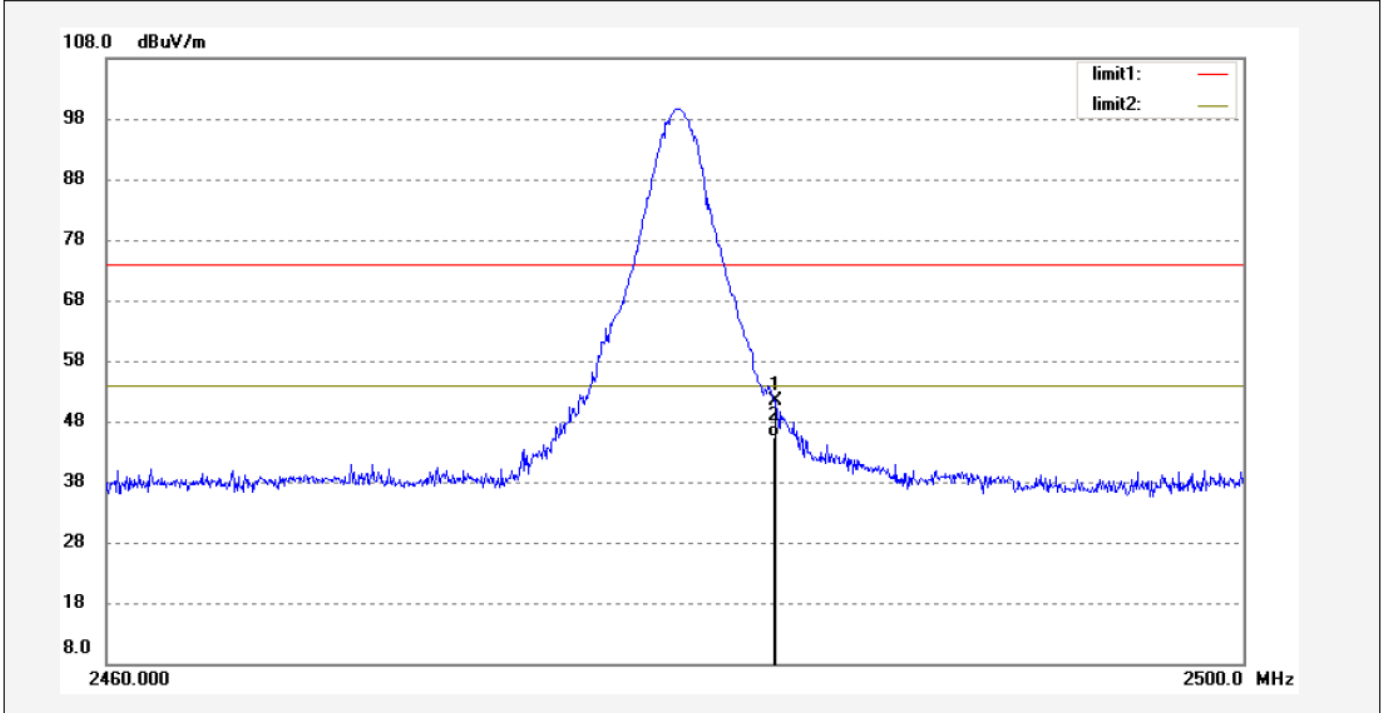

No.	Freq. (MHz)	Reading (dBuV/m)	Factor (dB)	Result (dBuV/m)	Limit (dBuV/m)	Margin (dB)	Detector	Height (cm)	Degree (deg.)	Remark
1	2483.529	58.66	-7.37	51.29	74.00	-22.71	peak			
2	2483.529	52.79	-7.37	45.42	54.00	-8.58	Peak			

Note: Average measurement with peak detection at No.2

Job No.: Ricky #188

Standard: FCC 15C PK

Test item: Radiation Test

Temp.( C)/Hum.(%) 23 C / 49 %

EUT: Suitcase Bluetooth Turntable

Mode: TX 2480MHz(PI/4DQPSK)

Model: CS-14001

Manufacturer: Jiayinking

Polarization: Vertical

Power Source: AC 120V/60Hz

Date: 2014/09/25

Time: 13/01/20

Engineer Signature: Ricky

Distance: 3m

Note: Report NO.:ATE20141861

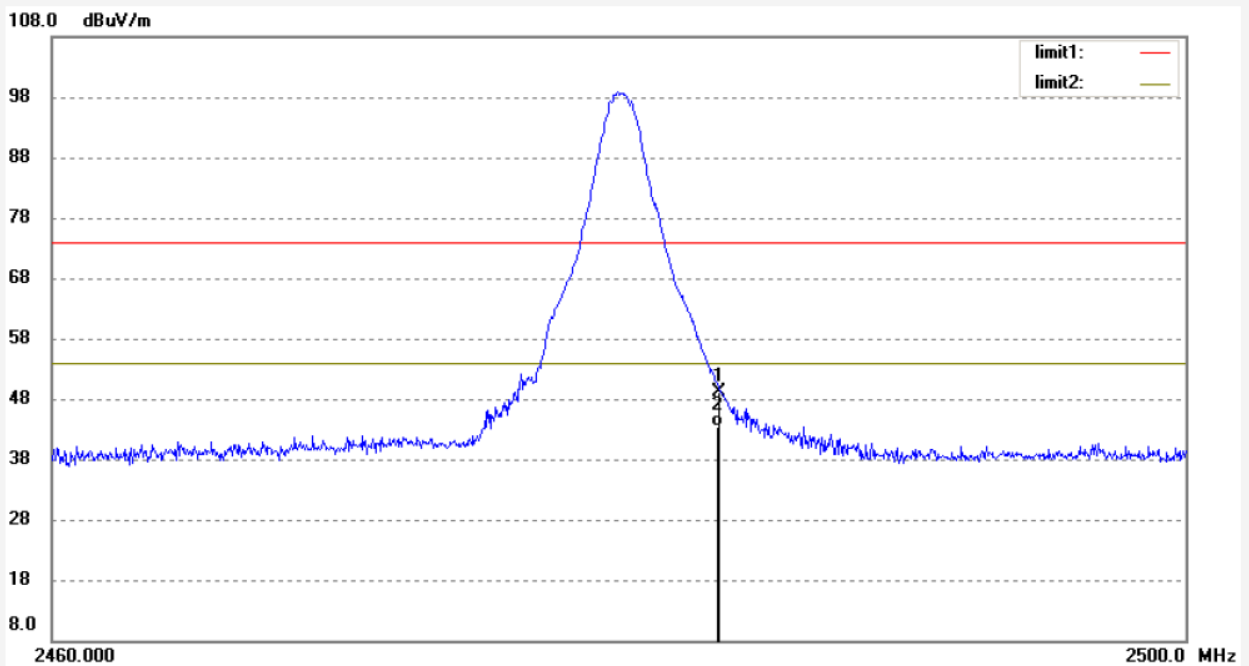

No.	Freq. (MHz)	Reading (dBuV/m)	Factor (dB)	Result (dBuV/m)	Limit (dBuV/m)	Margin (dB)	Detector	Height (cm)	Degree (deg.)	Remark
1	2483.529	56.56	-7.37	49.19	74.00	-24.81	peak			
2	2483.529	50.67	-7.37	43.30	54.00	-10.70	Peak			

Note: Average measurement with peak detection at No.2

Job No.: Ricky #189	Polarization: Vertical
Standard: FCC 15C PK	Power Source: AC 120V/60Hz
Test item: Radiation Test	Date: 2014/09/25
Temp.( C)/Hum.(%) 23 C / 49 %	Time: 13/03/35
EUT: Suitcase Bluetooth Turntable	Engineer Signature: Ricky
Mode: TX 2402MHz(8QPSK)	Distance: 3m
Model: CS-14001	
Manufacturer: Jiayingking	

Note: Report NO.:ATE20141861

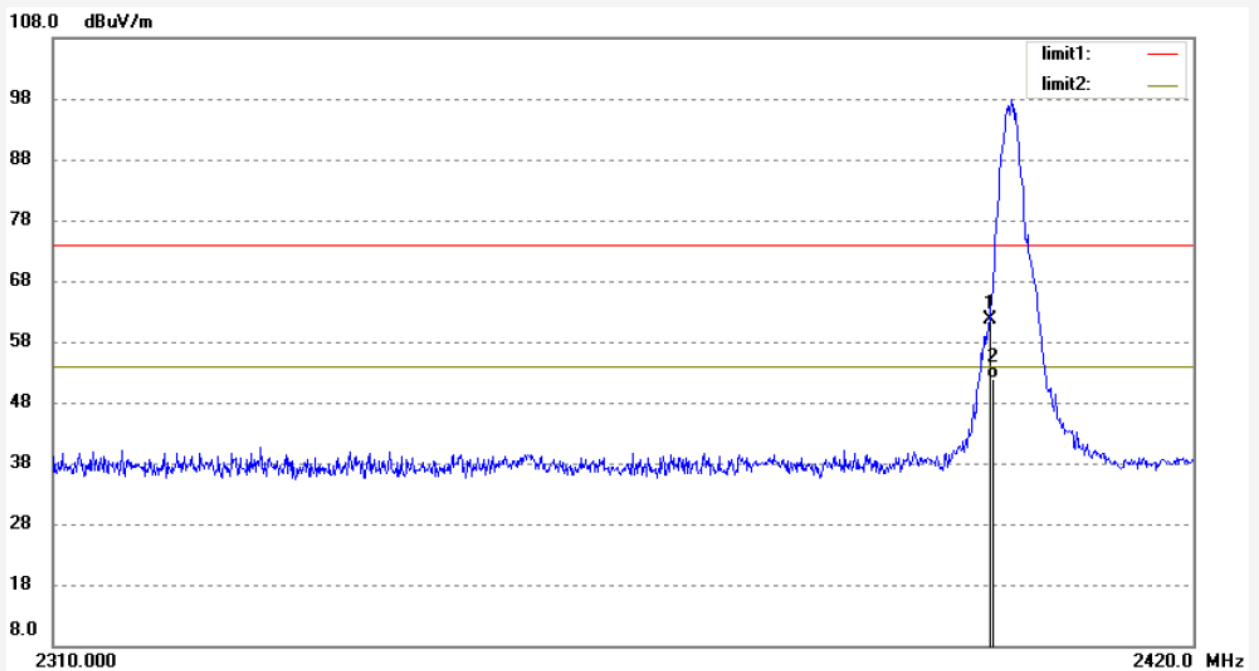

No.	Freq. (MHz)	Reading (dBuV/m)	Factor (dB)	Result (dBuV/m)	Limit (dBuV/m)	Margin (dB)	Detector	Height (cm)	Degree (deg.)	Remark
1	2400.000	69.03	-7.46	61.57	74.00	-12.43	peak			
2	2400.000	59.35	-7.46	51.89	54.00	-2.11	Peak			

Note: Average measurement with peak detection at No.2

Job No.: Ricky #190	Polarization: Horizontal
Standard: FCC 15C PK	Power Source: AC 120V/60Hz
Test item: Radiation Test	Date: 2014/09/25
Temp.( C)/Hum.(%) 23 C / 49 %	Time: 13/04/57
EUT: Suitcase Bluetooth Turntable	Engineer Signature: Ricky
Mode: TX 2402MHz(8QPSK)	Distance: 3m
Model: CS-14001	
Manufacturer: Jiayinking	

Note: Report NO.:ATE20141861

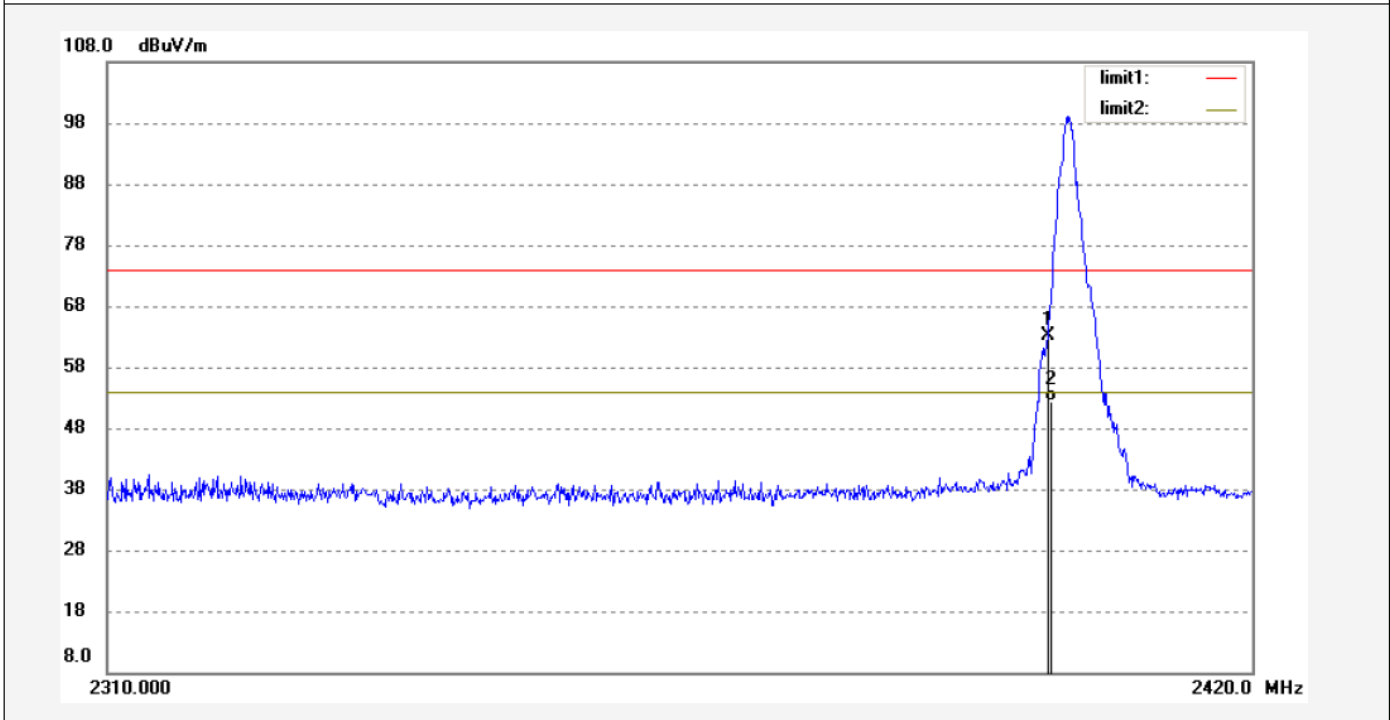

No.	Freq. (MHz)	Reading (dBuV/m)	Factor (dB)	Result (dBuV/m)	Limit (dBuV/m)	Margin (dB)	Detector	Height (cm)	Degree (deg.)	Remark
1	2400.000	70.56	-7.46	63.10	74.00	-10.90	peak			
2	2400.000	59.72	-7.46	52.26	54.00	-1.74	Peak			

Note: Average measurement with peak detection at No.2



Job No.: Ricky #191

Standard: FCC 15C PK

Test item: Radiation Test

Temp.( C)/Hum.(%) 23 C / 49 %

EUT: Suitcase Bluetooth Turntable

Mode: TX 2480MHz(8QPSK)

Model: CS-14001

Manufacturer: Jiayinking

Polarization: Horizontal

Power Source: AC 120V/60Hz

Date: 2014/09/25

Time: 13/06/19

Engineer Signature: Ricky

Distance: 3m

Note: Report NO.:ATE20141861

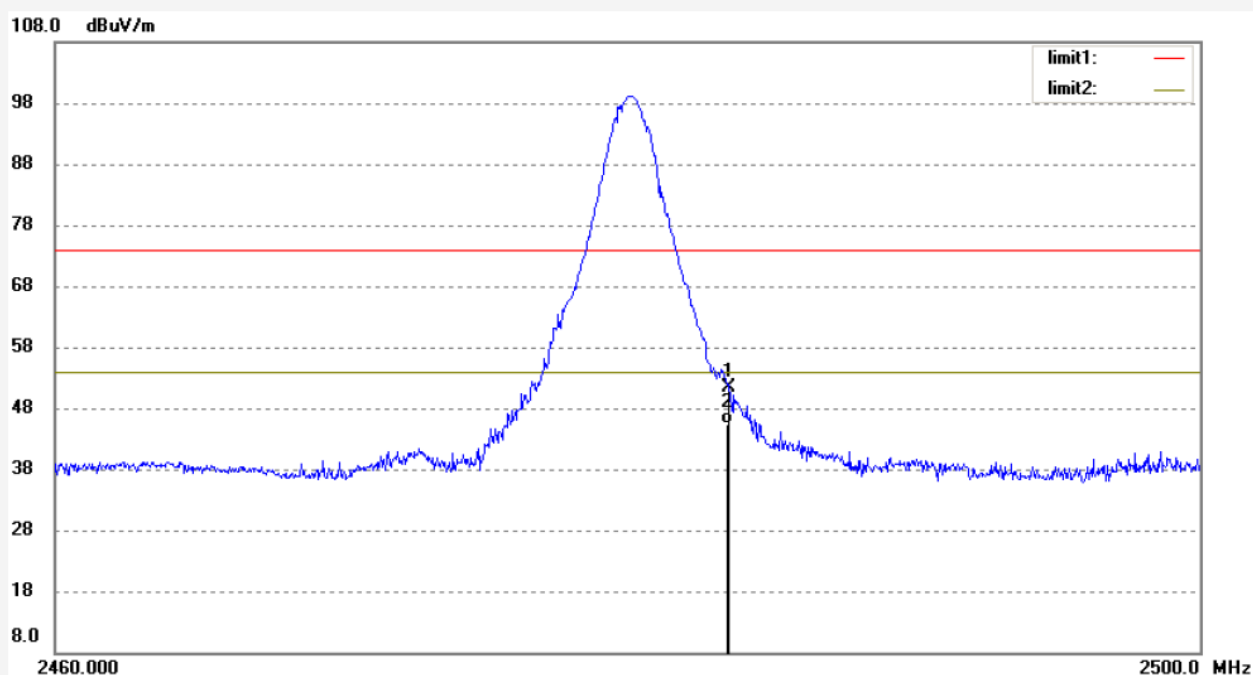

No.	Freq. (MHz)	Reading (dBuV/m)	Factor (dB)	Result (dBuV/m)	Limit (dBuV/m)	Margin (dB)	Detector	Height (cm)	Degree (deg.)	Remark
1	2483.529	58.67	-7.37	51.30	74.00	-22.70	peak			
2	2483.529	52.81	-7.37	45.44	54.00	-8.56	Peak			

Note: Average measurement with peak detection at No.2

Job No.: Ricky #192

Standard: FCC 15C PK

Test item: Radiation Test

Temp.( C)/Hum.(%) 23 C / 49 %

EUT: Suitcase Bluetooth Turntable

Mode: TX 2480MHz(8QPSK)

Model: CS-14001

Manufacturer: Jiayingking

Polarization: Vertical

Power Source: AC 120V/60Hz

Date: 2014/09/25

Time: 13/09/55

Engineer Signature: Ricky

Distance: 3m

Note: Report NO.:ATE20141861

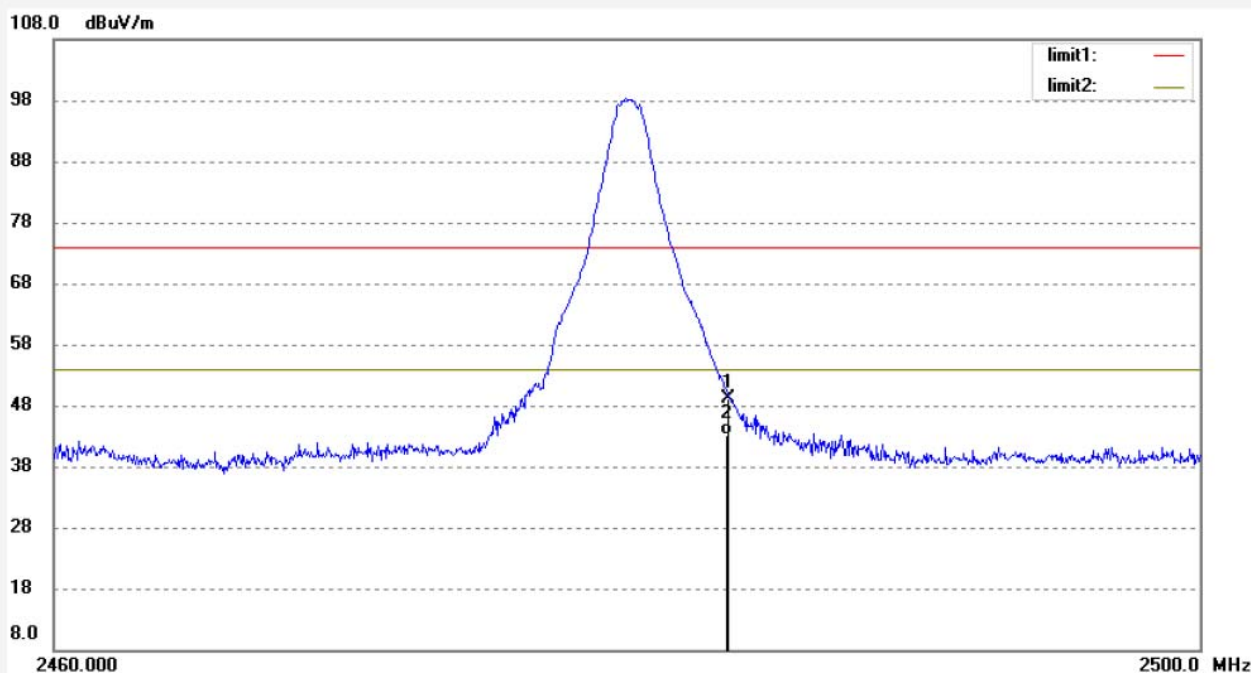

No.	Freq. (MHz)	Reading (dBuV/m)	Factor (dB)	Result (dBuV/m)	Limit (dBuV/m)	Margin (dB)	Detector	Height (cm)	Degree (deg.)	Remark
1	2483.529	56.44	-7.37	49.07	74.00	-24.93	peak			
2	2483.529	50.62	-7.37	43.25	54.00	-10.75	Peak			

Note: Average measurement with peak detection at No.2

### Hopping mode



## ACCURATE TECHNOLOGY CO., LTD.

F1,Bldg,A,Changyuan New Material Port Keyuan Rd,  
Science & Industry Park,Nanshan Shenzhen,P.R.China

Site: 1# Chamber

Tel:+86-0755-26503290

Fax:+86-0755-26503396

Job No.: STAR #3027

Standard: FCC PK

Test item: Radiation Test

Temp.( C)/Hum.(%) 25 C / 55 %

EUT: Suitcase Bluetooth Turntable

Mode: HOPPING (GFSK)

Model: CS-14001

Manufacturer: Jiayinking

Polarization: Horizontal

Power Source: AC 120V/60Hz

Date: 2014/09/25

Time: 11/22/51

Engineer Signature:

Distance: 3m

Note: Report NO.:ATE20141861

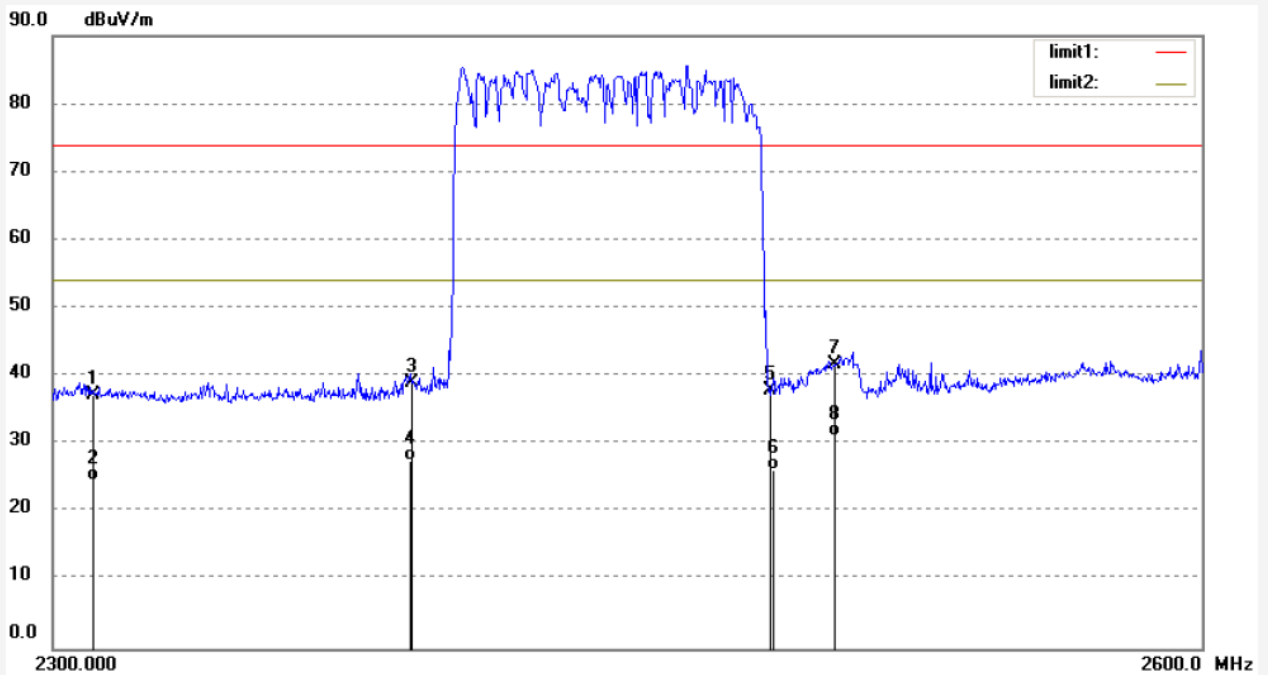

No.	Freq. (MHz)	Reading (dBuV/m)	Factor (dB)	Result (dBuV/m)	Limit (dBuV/m)	Margin (dB)	Detector	Height (cm)	Degree (deg.)	Remark
1	2310.000	44.18	-6.99	37.19	74.00	-36.81	peak			
2	2310.000	31.58	-6.99	24.59	54.00	-29.41	Peak			
3	2390.000	45.89	-6.78	39.11	74.00	-34.89	peak			
4	2390.000	34.25	-6.78	27.47	54.00	-26.53	Peak			
5	2483.500	44.36	-6.54	37.82	74.00	-36.18	peak			
6	2483.500	32.69	-6.54	26.15	54.00	-27.85	Peak			
7	2500.000	48.29	-6.50	41.79	74.00	-32.21	peak			
8	2500.000	37.66	-6.50	31.16	54.00	-22.84	Peak			

Note: Average measurement with peak detection at No.2, 4, 6, 8

**ACCURATE TECHNOLOGY CO., LTD.**

 F1,Bldg,A,Changyuan New Material Port Keyuan Rd,  
 Science & Industry Park,Nanshan Shenzhen,P.R.China

Site: 1# Chamber

Tel:+86-0755-26503290

Fax:+86-0755-26503396

Job No.: STAR #3028

Standard: FCC PK

Test item: Radiation Test

Temp.( C)/Hum.(%) 25 C / 55 %

EUT: Suitcase Bluetooth Turntable

Mode: HOPPING (GFSK)

Model: CS-14001

Manufacturer: Jiayingking

Polarization: Vertical

Power Source: AC 120V/60Hz

Date: 2014/09/25

Time: 11/25/42

Engineer Signature:

Distance: 3m

Note: Report NO.:ATE20141861

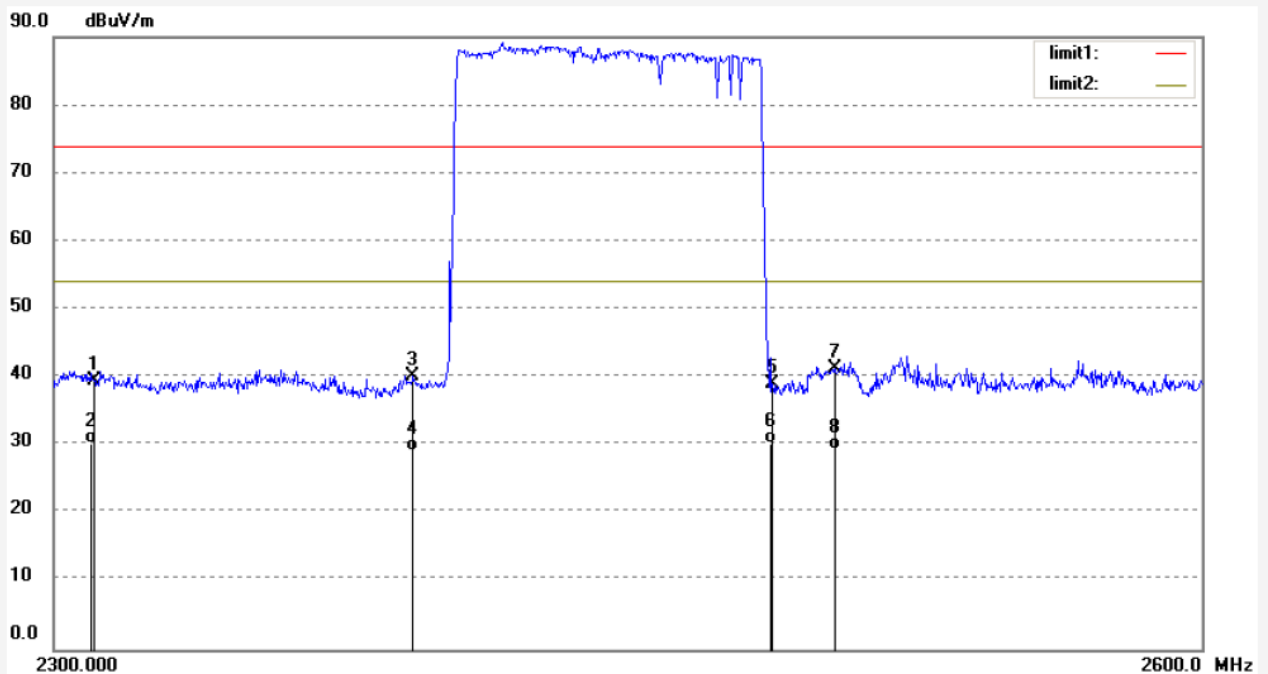

No.	Freq. (MHz)	Reading (dBuV/m)	Factor (dB)	Result (dBuV/m)	Limit (dBuV/m)	Margin (dB)	Detector	Height (cm)	Degree (deg.)	Remark
1	2310.000	46.43	-6.99	39.44	74.00	-34.56	peak			
2	2310.000	37.25	-6.99	30.26	54.00	-23.74	Peak			
3	2390.000	46.86	-6.78	40.08	74.00	-33.92	peak			
4	2390.000	35.86	-6.78	29.08	54.00	-24.92	Peak			
5	2483.500	45.50	-6.54	38.96	74.00	-35.04	peak			
6	2483.500	36.87	-6.54	30.33	54.00	-23.67	Peak			
7	2500.000	47.78	-6.50	41.28	74.00	-32.72	peak			
8	2500.000	35.88	-6.50	29.38	54.00	-24.62	Peak			

Note: Average measurement with peak detection at No.2, 4, 6, 8

Job No.: STAR #3029

Standard: FCC PK

Test item: Radiation Test

Temp.( C)/Hum.(%) 25 C / 55 %

EUT: Suitcase Bluetooth Turntable

Mode: HOPPING (PI/4DQPSK)

Model: CS-14001

Manufacturer: Jiayingking

Polarization: Vertical

Power Source: AC 120V/60Hz

Date: 2014/09/25

Time: 11/28/17

Engineer Signature:

Distance: 3m

Note: Report NO.:ATE20141861

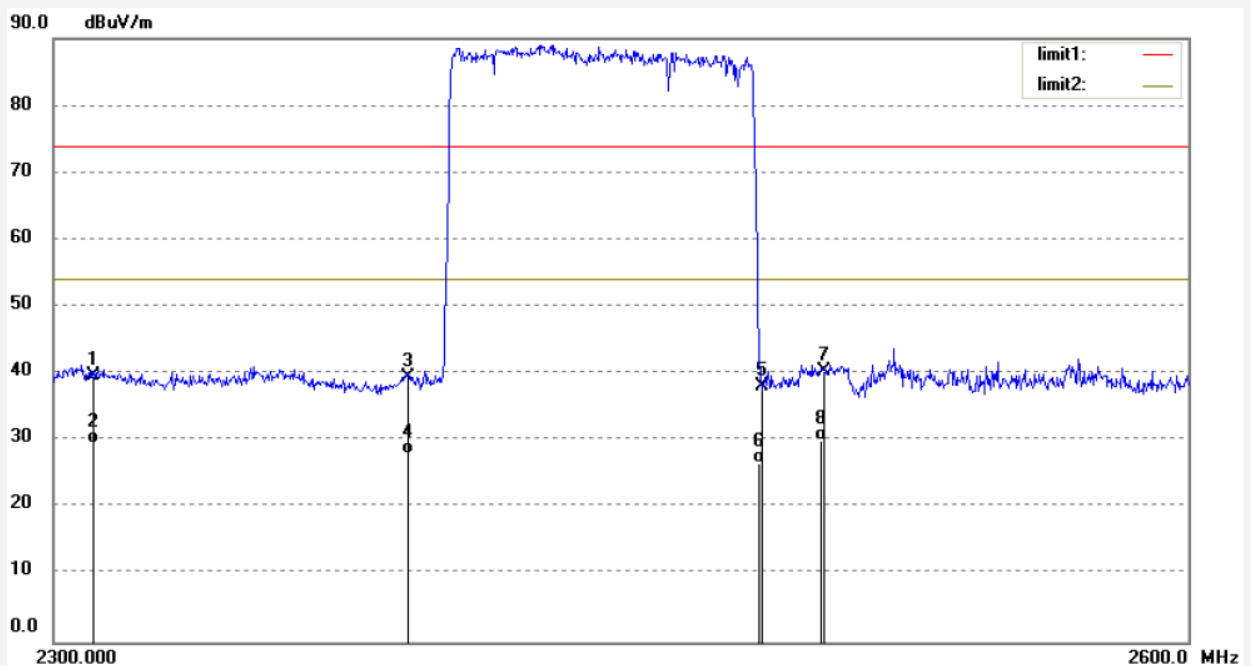

No.	Freq. (MHz)	Reading (dBuV/m)	Factor (dB)	Result (dBuV/m)	Limit (dBuV/m)	Margin (dB)	Detector	Height (cm)	Degree (deg.)	Remark
1	2310.000	46.75	-6.99	39.76	74.00	-34.24	peak			
2	2310.000	36.55	-6.99	29.56	54.00	-24.44	Peak			
3	2390.000	46.28	-6.78	39.50	74.00	-34.50	peak			
4	2390.000	34.89	-6.78	28.11	54.00	-25.89	Peak			
5	2483.500	44.59	-6.54	38.05	74.00	-35.95	peak			
6	2483.500	33.24	-6.54	26.70	54.00	-27.30	Peak			
7	2500.000	46.93	-6.50	40.43	74.00	-33.57	peak			
8	2500.000	36.43	-6.50	29.93	54.00	-24.07	Peak			

Note: Average measurement with peak detection at No.2, 4, 6, 8

Job No.: STAR #3030

Standard: FCC PK

Test item: Radiation Test

Temp.( C)/Hum.(%) 25 C / 55 %

EUT: Suitcase Bluetooth Turntable

Mode: HOPPING (PI/4DQPSK)

Model: CS-14001

Manufacturer: Jiayingking

Polarization: Horizontal

Power Source: AC 120V/60Hz

Date: 2014/09/25

Time: 11/31/16

Engineer Signature:

Distance: 3m

Note: Report NO.:ATE20141861

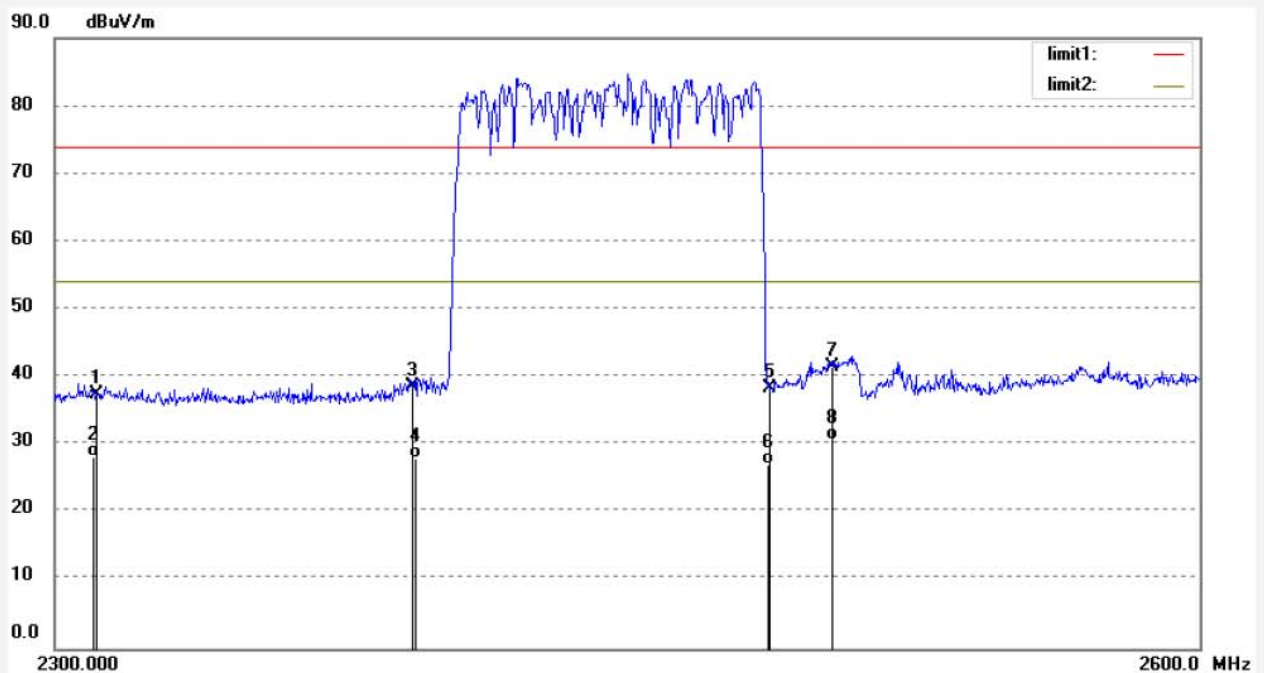

No.	Freq. (MHz)	Reading (dBuV/m)	Factor (dB)	Result (dBuV/m)	Limit (dBuV/m)	Margin (dB)	Detector	Height (cm)	Degree (deg.)	Remark
1	2310.000	44.36	-6.99	37.37	74.00	-36.63	peak			
2	2310.000	35.24	-6.99	28.25	54.00	-25.75	Peak			
3	2390.000	45.45	-6.78	38.67	74.00	-35.33	peak			
4	2390.000	34.80	-6.78	28.02	54.00	-25.98	Peak			
5	2483.500	44.82	-6.54	38.28	74.00	-35.72	peak			
6	2483.500	33.58	-6.54	27.04	54.00	-26.96	Peak			
7	2500.000	48.09	-6.50	41.59	74.00	-32.41	peak			
8	2500.000	37.32	-6.50	30.82	54.00	-23.18	Peak			

Note: Average measurement with peak detection at No.2, 4, 6, 8

Job No.: STAR #3031

Standard: FCC PK

Test item: Radiation Test

Temp.( C)/Hum.(%) 25 C / 55 %

EUT: Suitcase Bluetooth Turntable

Mode: HOPPING (8QPSK)

Model: CS-14001

Manufacturer: Jiayinking

Polarization: Horizontal

Power Source: AC 120V/60Hz

Date: 2014/09/25

Time: 11/36/34

Engineer Signature:

Distance: 3m

Note: Report NO.:ATE20141861

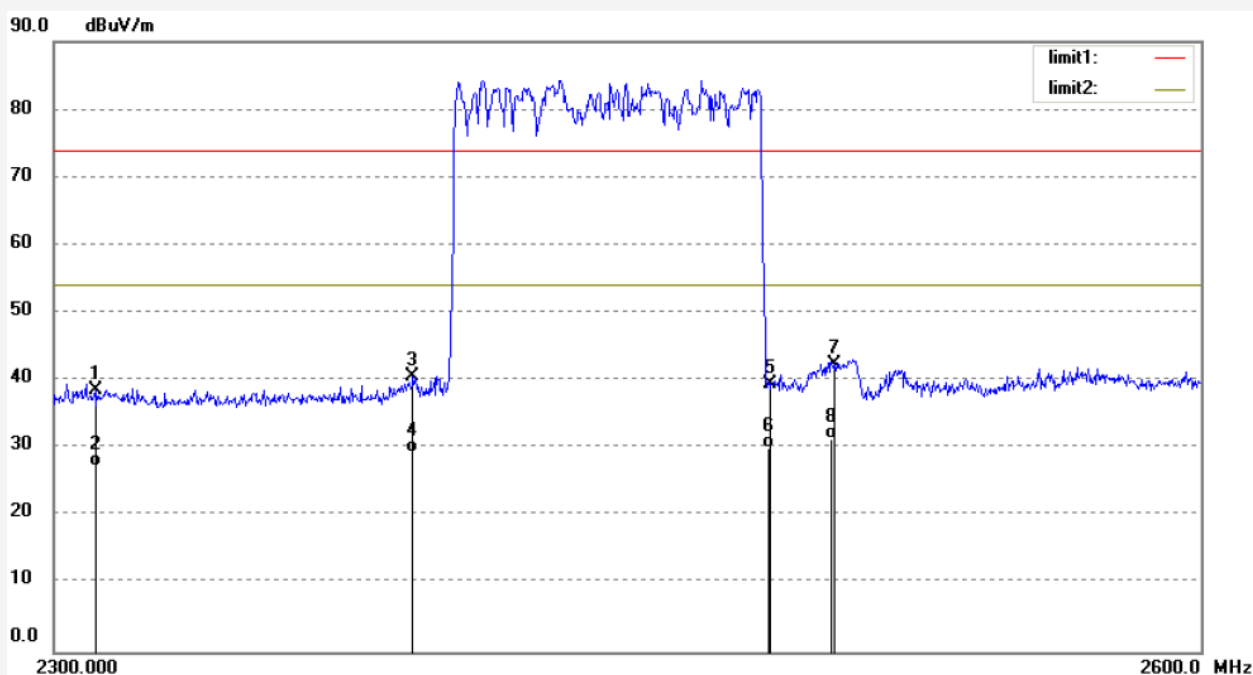

No.	Freq. (MHz)	Reading (dBuV/m)	Factor (dB)	Result (dBuV/m)	Limit (dBuV/m)	Margin (dB)	Detector	Height (cm)	Degree (deg.)	Remark
1	2310.000	45.68	-6.99	38.69	74.00	-35.31	peak			
2	2310.000	34.29	-6.99	27.30	54.00	-26.70	Peak			
3	2390.000	47.42	-6.78	40.64	74.00	-33.36	peak			
4	2390.000	36.10	-6.78	29.32	54.00	-24.68	Peak			
5	2483.500	45.92	-6.54	39.38	74.00	-34.62	peak			
6	2483.500	36.61	-6.54	30.07	54.00	-23.93	Peak			
7	2500.000	48.96	-6.50	42.46	74.00	-31.54	peak			
8	2500.000	37.88	-6.50	31.38	54.00	-22.62	Peak			

Note: Average measurement with peak detection at No.2, 4, 6, 8

Job No.: STAR #3032

Standard: FCC PK

Test item: Radiation Test

Temp.( C)/Hum.(%) 25 C / 55 %

EUT: Suitcase Bluetooth Turntable

Mode: HOPPING (8QPSK)

Model: CS-14001

Manufacturer: Jiayingking

Polarization: Vertical

Power Source: AC 120V/60Hz

Date: 2014/09/25

Time: 11/39/37

Engineer Signature:

Distance: 3m

Note: Report NO.:ATE20141861

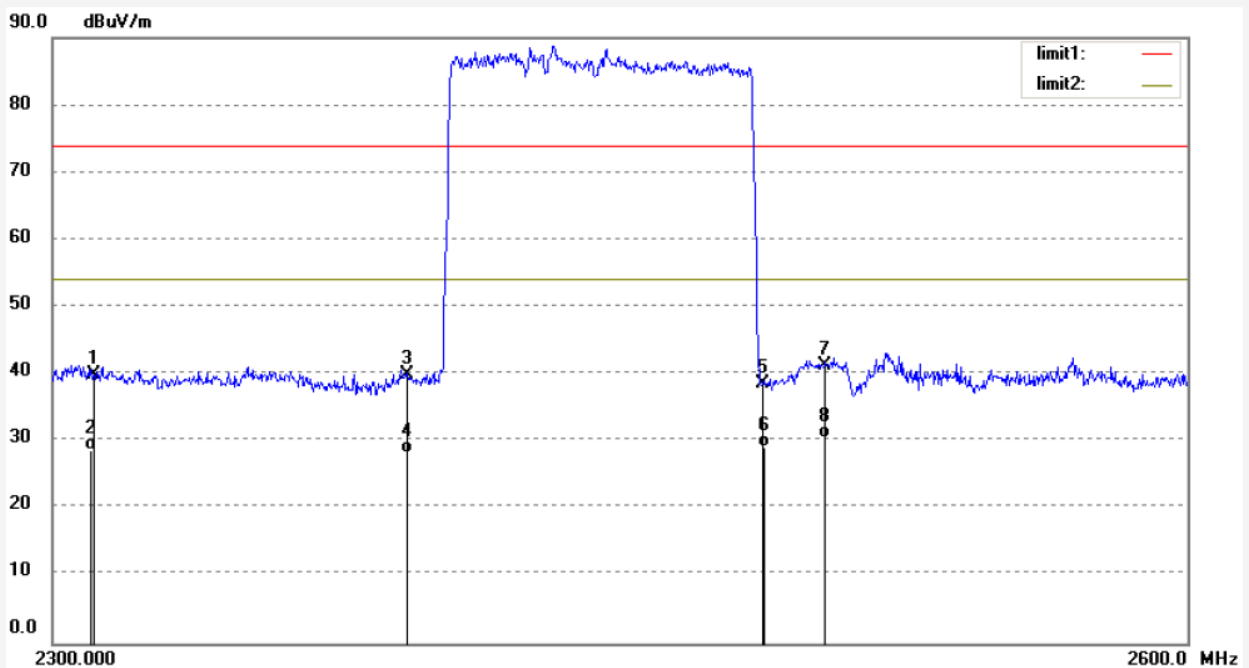

No.	Freq. (MHz)	Reading (dBuV/m)	Factor (dB)	Result (dBuV/m)	Limit (dBuV/m)	Margin (dB)	Detector	Height (cm)	Degree (deg.)	Remark
1	2310.000	46.88	-6.99	39.89	74.00	-34.11	peak			
2	2310.000	35.60	-6.99	28.61	54.00	-25.39	Peak			
3	2390.000	46.74	-6.78	39.96	74.00	-34.04	peak			
4	2390.000	35.10	-6.78	28.32	54.00	-25.68	Peak			
5	2483.500	45.21	-6.54	38.67	74.00	-35.33	peak			
6	2483.500	35.66	-6.54	29.12	54.00	-24.88	Peak			
7	2500.000	47.76	-6.50	41.26	74.00	-32.74	peak			
8	2500.000	36.91	-6.50	30.41	54.00	-23.59	Peak			

Note: Average measurement with peak detection at No.2, 4, 6, 8



## 12.AC POWER LINE CONDUCTED EMISSION FOR FCC PART

### 15 SECTION 15.207(A)

#### 12.1.Block Diagram of Test Setup

##### 12.1.1.Shielding Room Test Setup Diagram

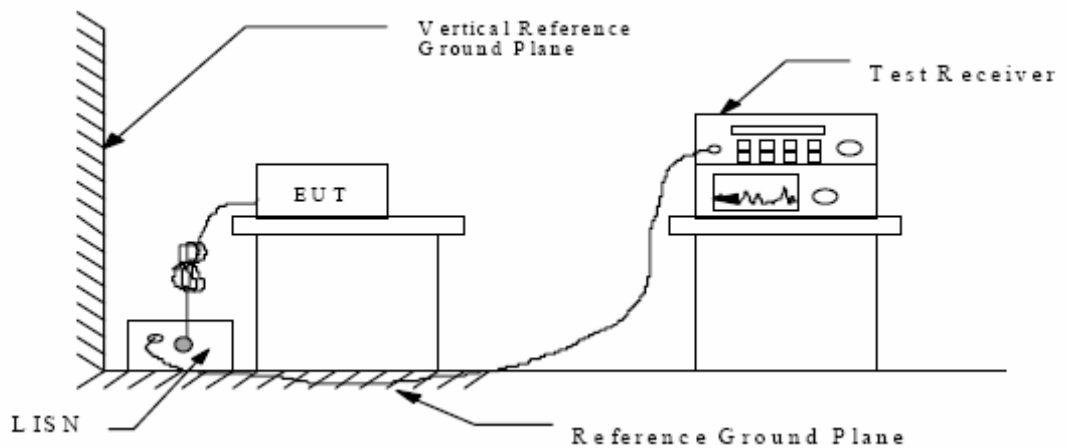

#### 12.2.The Emission Limit

##### 12.2.1.Conducted Emission Measurement Limits According to Section 15.207(a)

Frequency (MHz)	Limit dB(μV)	
	Quasi-peak Level	Average Level
0.15 - 0.50	66.0 – 56.0 *	56.0 – 46.0 *
0.50 - 5.00	56.0	46.0
5.00 - 30.00	60.0	50.0

\* Decreases with the logarithm of the frequency.

### 12.3.Configuration of EUT on Measurement

The equipment are installed on the Conducted Emission Measurement to meet the commission requirements and operating regulations in a manner which tends to maximize its emission characteristics in normal application.

### 12.4.Operating Condition of EUT

12.4.1.Setup the EUT and simulator as shown as Section 11.1.

12.4.2.Turn on the power of all equipment.

12.4.3.Let the EUT work in Test mode measure it.

### 12.5.Test Procedure

The EUT is put on the plane 0.8m high above the ground by insulating support and is connected to the power mains through a line impedance stabilization network (L.I.S.N.). This provides a 50ohm coupling impedance for the EUT system. Please refer the block diagram of the test setup and photographs. Both sides of AC lines are checked to find out the maximum conducted emission. In order to find the maximum emission levels, the relative positions of equipment and all of the interface cables shall be changed according to ANSI C63.4- 2009 on Conducted Emission Measurement.

The bandwidth of test receiver (R & S ESCS30) is set at 9 kHz.

The frequency range from 150 kHz to 30MHz is checked.

### 12.6.Power Line Conducted Emission Measurement Results

**PASS.**

The frequency range from 150kHz to 30MHz is checked.

Test mode : BT Operation								
<b>MEASUREMENT RESULT: "QP-0926-05_fin"</b>								
9/26/2014 4:44PM								
Frequency MHz	Level dBµV	Transd dB	Limit dBµV	Margin dB	Detector	Line	PE	
1.365000	34.70	10.9	56	21.3	QP	L1	GND	
2.200000	36.70	11.0	56	19.3	QP	L1	GND	
2.500000	31.10	11.0	56	24.9	QP	L1	GND	
<b>MEASUREMENT RESULT: "QP-0926-05_fin2"</b>								
9/26/2014 4:44PM								
Frequency MHz	Level dBµV	Transd dB	Limit dBµV	Margin dB	Detector	Line	PE	
0.425000	27.90	10.7	47	19.4	AV	L1	GND	
1.375000	30.70	10.9	46	15.3	AV	L1	GND	
2.190000	32.80	11.0	46	13.2	AV	L1	GND	
<b>MEASUREMENT RESULT: "QP-0926-03_fin"</b>								
9/26/2014 4:34PM								
Frequency MHz	Level dBµV	Transd dB	Limit dBµV	Margin dB	Detector	Line	PE	
0.185000	45.60	10.5	64	18.7	QP	N	GND	
0.435000	36.40	10.7	57	20.8	QP	N	GND	
2.380000	36.00	11.0	56	20.0	QP	N	GND	
<b>MEASUREMENT RESULT: "QP-0926-03_fin2"</b>								
9/26/2014 4:34PM								
Frequency MHz	Level dBµV	Transd dB	Limit dBµV	Margin dB	Detector	Line	PE	
0.195000	24.30	10.5	54	29.5	AV	N	GND	
0.440000	25.50	10.7	47	21.6	AV	N	GND	
2.400000	21.90	11.0	46	24.1	AV	N	GND	

Emissions attenuated more than 20 dB below the permissible value are not reported.

The spectral diagrams are attached as below.

**ACCURATE TECHNOLOGY CO., LTD**

**CONDUCTED EMISSION STANDARD FCC PART 15B**

EUT: Suitcase Bluetooth Turntable M/N:CS-14001  
 Manufacturer: Jiayinking  
 Operating Condition: BT Operation  
 Test Site: 1#Shielding Room  
 Operator: Carry  
 Test Specification: L 120V/60Hz  
 Comment: Report NO.:ATE20141861  
 Start of Test: 9/26/2014 / 4:43:42PM

**SCAN TABLE: "V 150K-30MHZ fin"**

Short Description: \_SUB\_STD\_VTERM2 1.70  
 Start Stop Step Detector Meas. IF Transducer  
 Frequency Frequency Width Time Bandw.  
 150.0 kHz 30.0 MHz 4.5 kHz QuasiPeak 1.0 s 9 kHz NSLK8126 2008  
 Average

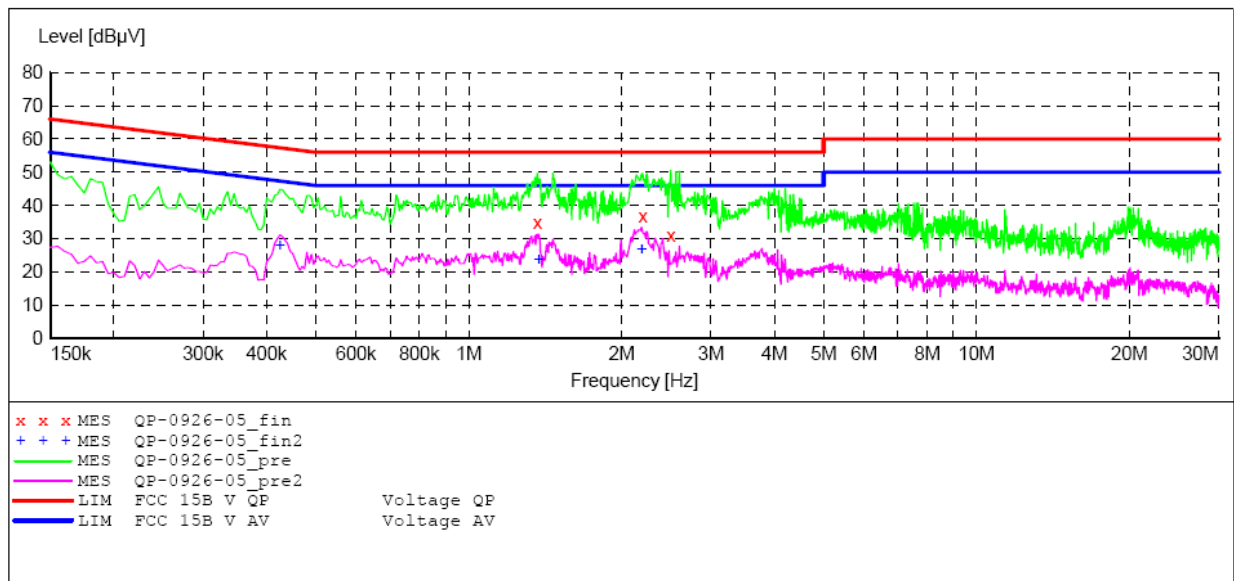

**MEASUREMENT RESULT: "QP-0926-05\_fin"**

9/26/2014 4:44PM

Frequency MHz	Level dBµV	Transd dB	Limit dBµV	Margin dB	Detector	Line	PE
1.365000	34.70	10.9	56	21.3	QP	L1	GND
2.200000	36.70	11.0	56	19.3	QP	L1	GND
2.500000	31.10	11.0	56	24.9	QP	L1	GND

**MEASUREMENT RESULT: "QP-0926-05\_fin2"**

9/26/2014 4:44PM

Frequency MHz	Level dBµV	Transd dB	Limit dBµV	Margin dB	Detector	Line	PE
0.425000	27.90	10.7	47	19.4	AV	L1	GND
1.375000	30.70	10.9	46	15.3	AV	L1	GND
2.190000	32.80	11.0	46	13.2	AV	L1	GND

**ACCURATE TECHNOLOGY CO., LTD**

**CONDUCTED EMISSION STANDARD FCC PART 15B**

EUT: Suitcase Bluetooth Turntable M/N:CS-14001  
 Manufacturer: Jiayinking  
 Operating Condition: BT Operation  
 Test Site: 1#Shielding Room  
 Operator: Carry  
 Test Specification: N 120V/60Hz  
 Comment: Report NO.:ATE20141861  
 Start of Test: 9/26/2014 / 4:30:05PM

**SCAN TABLE: "V 150K-30MHZ fin"**

Short Description: \_SUB\_STD\_VTERM2 1.70  
 Start Stop Step Detector Meas. IF Transducer  
 Frequency Frequency Width Time Bandw.  
 150.0 kHz 30.0 MHz 4.5 kHz QuasiPeak 1.0 s 9 kHz NSLK8126 2008  
 Average

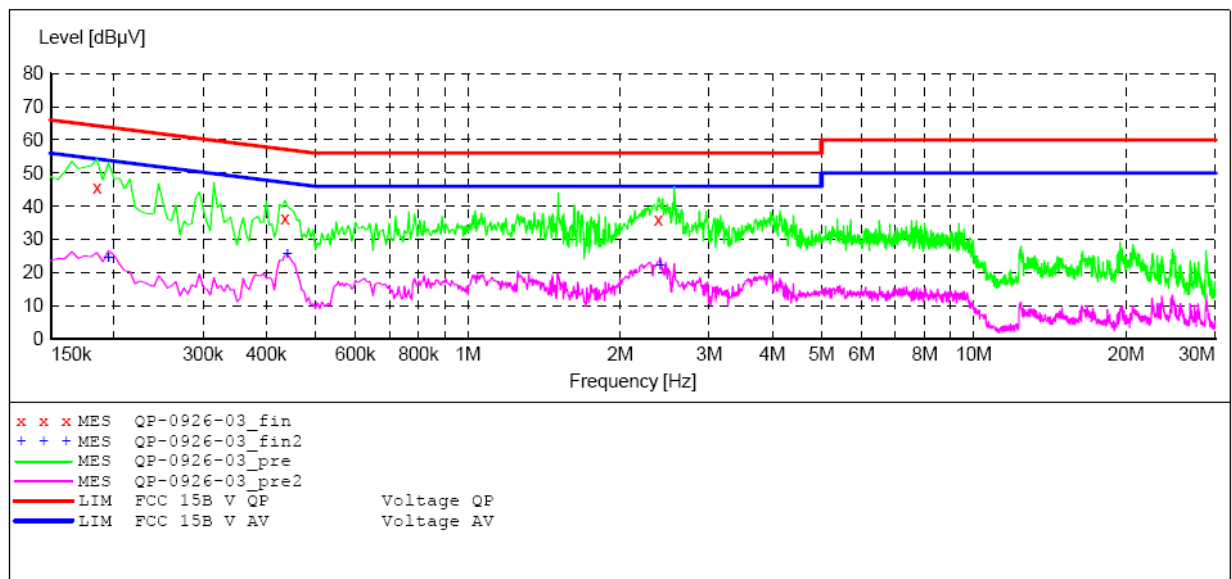

**MEASUREMENT RESULT: "QP-0926-03\_fin"**

9/26/2014 4:34PM

Frequency MHz	Level dBuV	Transd dB	Limit dBuV	Margin dB	Detector	Line	PE
0.185000	45.60	10.5	64	18.7	QP	N	GND
0.435000	36.40	10.7	57	20.8	QP	N	GND
2.380000	36.00	11.0	56	20.0	QP	N	GND

**MEASUREMENT RESULT: "QP-0926-03\_fin2"**

9/26/2014 4:34PM

Frequency MHz	Level dBuV	Transd dB	Limit dBuV	Margin dB	Detector	Line	PE
0.195000	24.30	10.5	54	29.5	AV	N	GND
0.440000	25.50	10.7	47	21.6	AV	N	GND
2.400000	21.90	11.0	46	24.1	AV	N	GND

## 13.ANTENNA REQUIREMENT

### 13.1.The Requirement

According to Section 15.203, an intentional radiator shall be designed to ensure that no antenna other than that furnished by the responsible party shall be used with the device.

### 13.2.Antenna Construction

The antenna is PCB Layout antenna, no consideration of replacement. Therefore, the equipment complies with the antenna requirement of Section 15.203.

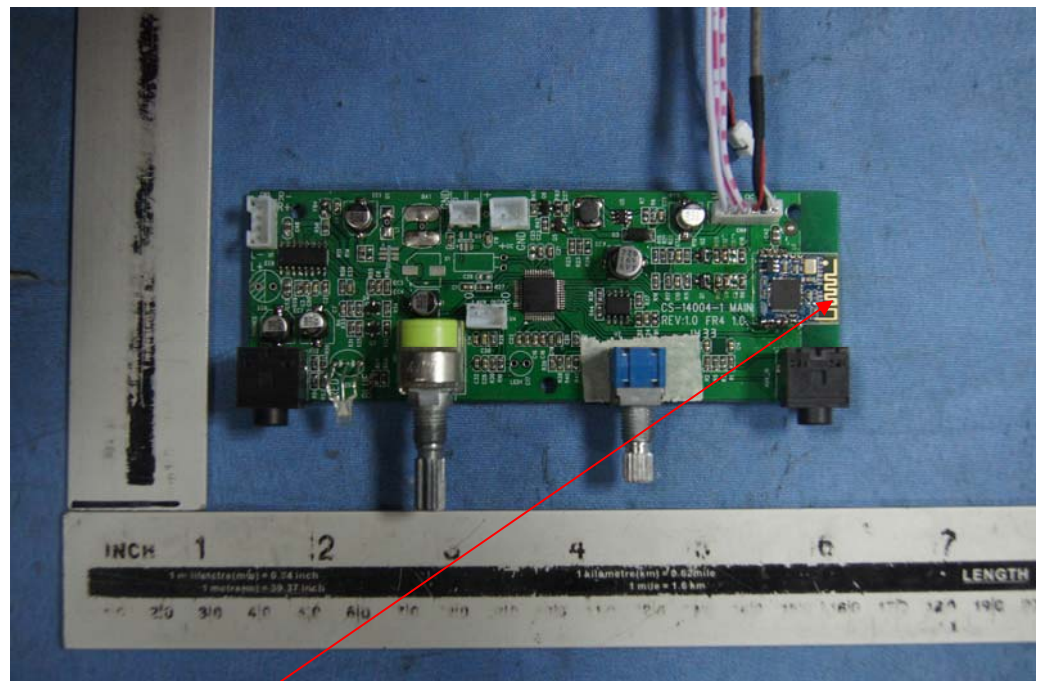

Antenna