

Test Report of FCC CFR 47 Part 15 Subpart C

On Behalf of

Prentke Romich Company, LLC

FCC ID: 2AD9PACN1400

Product Description: Accent 1400

Model No.: ACN1400

Supplementary Model: N/A

Brand Name:  Accentⁱ1400

Prepared for: Prentke Romich Company, LLC

1022 Heyl Rd. Wooster, Ohio 44691

Prepared by: Shenzhen QC Testing Laboratory Co., Ltd.

1st Floor, Building A, Huawan Industrial Park, Gushu, Xixiang Street,
Baoan, 518126, Shenzhen, China

Tel: 0755-23008269

Fax: 0755-23726780

Report No.: QCT15BR-1201E-3

Issue Date: March 06, 2015

Test Date: February 12~March 06, 2015

Tested by:



Kare Gao

Reviewed by:

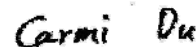

Carmi Du

Approved by:



Kandy Wang

TABLE OF CONTENTS

1. GENERAL INFORMATION..... 3
1.1 PRODUCT DESCRIPTION FOR EQUIPMENT UNDER TEST (EUT)..... 3
1.2 TEST STANDARDS 4
1.3 TEST METHODOLOGY 4
1.4 TEST FACILITY 4

2. SYSTEM TEST CONFIGURATION 5
2.1 EUT CONFIGURATION 5
2.2 EUT EXERCISE..... 5
2.3 GENERAL TEST PROCEDURES 5
2.4 MEASUREMENT UNCERTAINTY 5
2.5 TEST EQUIPMENT LIST AND DETAILS 6

3. SUMMARY OF TEST RESULTS 6

4. TEST OF AC POWER LINE CONDUCTED EMISSION 7
4.1 APPLICABLE STANDARD..... 7
4.2 TEST SETUP DIAGRAM 7
4.3 TEST RESULT 7

5. TEST OF RADIATED EMISSION 10
5.1 APPLICABLE STANDARD..... 10
5.2 LIMIT OF RADIATED DISTURBANCES 10
5.3 EUT SETUP 11
5.4 TEST EQUIPMENT LIST AND DETAILS 12
5.5 TEST PROCEDURE 12
5.6 TEST RESULT 12

6. FREQUENCY TOLERANCE 16
6.1 APPLICABLE STANDARD..... 16
6.2 EUT SETUP 16
6.3 TEST EQUIPMENT LIST AND DETAILS 16
6.4 TEST PROCEDURE 16
6.5 TEST RESULT 16

7. ANTENNA REQUIREMENT 18
7.1 STANDARD APPLICABLE..... 18
7.2 ANTENNA CONNECTED CONSTRUCTION 18

1. GENERAL INFORMATION

1.1 Product Description for Equipment Under Test (EUT)

Client Information

Applicant:	Prentke Romich Company, LLC
Address of Applicant:	1022 Heyl Rd. Wooster, Ohio 44691
Manufacturer:	Prentke Romich Company, LLC
Address of Manufacturer:	1022 Heyl Rd. Wooster, Ohio 44691

General Description of E.U.T

Items	Description
EUT Description:	Accent 1400
Model No.:	ACN1400
Supplementary Model:	N/A
Trade Name:	
Transmit Frequency:	13.56MHz
Number of Channels:	1
Duty cycle:	100%
Antenna Type:	Built-in Antenna
Power Supply:	Input: 12VDC 3.0A from AC/DC adapter;7.4VDC from battery
Adapter Information:	Model No: MENB1060A1800N02; Manufacturer: SL POWER and AULT Input: 100-240V~ 50-60Hz 1.5A Max ; Output:18.0V 3.4A

Remark: * The test data gathered are from the production sample provided by the manufacturer.

1.2 Test Standards

The tests were performed in order to determine compliance with FCC Part 15, Subpart C, and section 15.207, 15.209 and 15.225 rules. Test was carried out according to the above mentioned FCC rules.

1.3 Test Methodology

All measurements contained in this report were conducted with CISPR 16-1-1: 2006, radio disturbance and immunity measuring apparatus, and CISPR 16-2-3: 2010, Method of measurement of disturbances and immunity. All measurement required was performed at Shenzhen CTL Testing Technology Co., Ltd. at Floor 1-A, Baisha Technology Park, No.3011, Shahexi Road, Nanshan District, Shenzhen, China 518055

1.4 Test Facility

The test facility is recognized, certified, or accredited by the following organizations:

CNAS – Registration No.: L5540

Shenzhen CTL Testing Technology Co., Ltd. To ISO/IEC 17025:25 General Requirements for the Competence of Testing and Calibration Laboratories (CNAS-CL01 Accreditation Criteria for the Competence of Testing and Calibration Laboratories) for the competence in the field of testing. The acceptance letter from the CNAS is maintained in our files: Registration: L5540, March, 2012.

FCC – Registration No.: 970318

Shenzhen CTL Testing Technology Co., Ltd. EMC Laboratory has been Registered and fully described in a report filed with the (FCC) Federal Communications Commission. The acceptance letter from the FCC is maintained in our files. Registration: 970318, December 19, 2013.

2. SYSTEM TEST CONFIGURATION

2.1 EUT Configuration

The EUT configuration for testing is installed on RF field strength measurement to meet the Commissions requirement and operating in a manner that intends to maximize its emission characteristics in a continuous normal application.

2.2 EUT Exercise

The calibrated antennas used to sample the radiated field strength are mounted on a non-conductive, motorized antenna mast 3 or 10 meters from the leading edge of the turntable.

2.3 General Test Procedures

Conducted Emissions: The EUT is placed on the turntable, which is 0.8 m above ground plane. According to the requirements in Section 7.1 of ANSI C63.4-2003 Conducted emissions from the EUT measured in the frequency range between 0.15 MHz and 30MHz using CISPR Quasi-Peak detector mode.

Radiated Emissions: The EUT is a placed on as turntable, which is 0.8 m above ground plane. The turntable shall rotate 360 degrees to determine the position of maximum emission level. EUT is set 3m away from the receiving antenna, which varied from 1m to 4m to find out the highest emission. And also, each emission was to be maximized by changing the polarization of receiving antenna both horizontal and vertical. In order to find out the maximum emissions, exploratory radiated emission measurements were made according to the requirements in Section 13.1.4.1 of ANSI C63.4-2003.

2.4 Measurement Uncertainty

Where relevant, the following measurement uncertainty levels have been estimated for tests performed on the apparatus:

Parameter	Uncertainty
Power Line Conducted Emission	+/- 2.3 dB
Radiated Emission	+/- 3.4 dB

Uncertainty figures are valid to a confidence level of 95%.

2.5 Test Equipment List and Details

Test equipments list of Shenzhen CTL Testing Technology Co., Ltd.

Item	Test Equipment	Manufacturer	Model No.	Serial No.	Last Cal.
1	ULTRA-BROADBAND ANTENNA	Sunol Sciences Corp.	JB1 Antenna	A061713	2014.05.22
2	EMI TEST RECEIVER	ROHDE & SCHWARZ	ESCI	1166.5950.03	2014.03.19
3	Coaxial	/	/	/	2014.05.22
4	Controller	EM Electronics	Controller EM 1000	N/A	2014.05.22
5	Horn antenna	Sunol sciences corp	DRH-118	A062013	2014.07.22
6	Horn antenna	SCHWARZBECK	BBHA9710	1562	2014.07.22
7	Loop antenna	ZHINAN	ZN30900A	3548	2014.07.22
8	Amplifier	HP	8447D	1937A02492	2014.4.25
9	Broadband preamplifier	SCHWARZBECK	BBV9718	9718-182	2014.4.25
10	Spectrum Analyzer	R&S	FSP	100397	2014.05.22

3. SUMMARY OF TEST RESULTS

FCC Rules	Description of Test	Result
FCC §15.207	AC Power Line Conducted Emission	Pass
FCC §15.225(a)(b)(c)(d)	Radiated Emission (9kHz ~ 30MHz)	Pass
FCC §15.225(d), 15.209	Radiated Emission (30MHz ~ 1GHz)	Pass
FCC §15.225(e)	Frequency stability	Pass

4. TEST OF AC POWER LINE CONDUCTED EMISSION

4.1 Applicable Standard

Refer to FCC §15.207.

For a Low-power Radio-frequency Device is designed to be connected to the AC power line, the radio frequency voltage that is conducted back onto the AC power line on any frequency or frequencies within the band 150 kHz to 30 MHz shall not exceed below limits table.

Frequency Range (MHz)	Limits (dBuV)	
	Quasi-Peak	Average
0.150~0.500	66~56	56~46
0.500~5.000	56	46
5.000~30.00	60	50

4.2 Test Setup Diagram

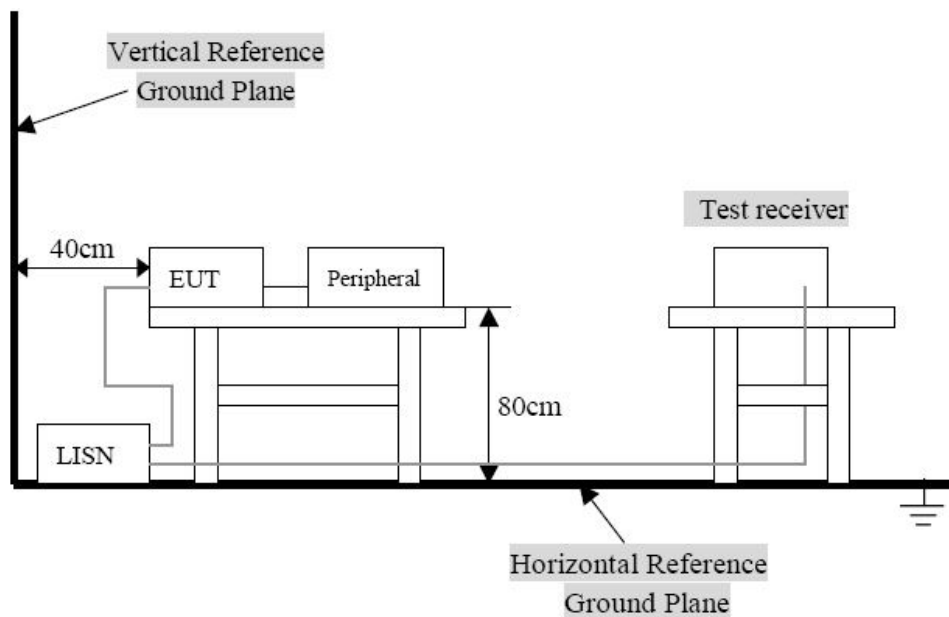

Remark: The EUT was connected to a 120VAC/ 60Hz power source.

4.3 Test Result

Temperature (°C) : 23~25	EUT: Accent 1400
Humidity (%RH) : 45~58	M/N: ACN1400
Barometric Pressure (mbar) : 950~1000	Operation Condition: Normal Operation

Conducted Emission Test Data

EUT: Accent 1400
 Operating Condition: Normal Operation
 Test Site: Shielded Room
 Operator: Andy
 Test Specification: AC/DC adapter (AC 120V/60Hz)
 Comment: Live Line

SCAN TABLE: "Voltage (9K-30M) FIN"
 Short Description: 150K-30M Voltage

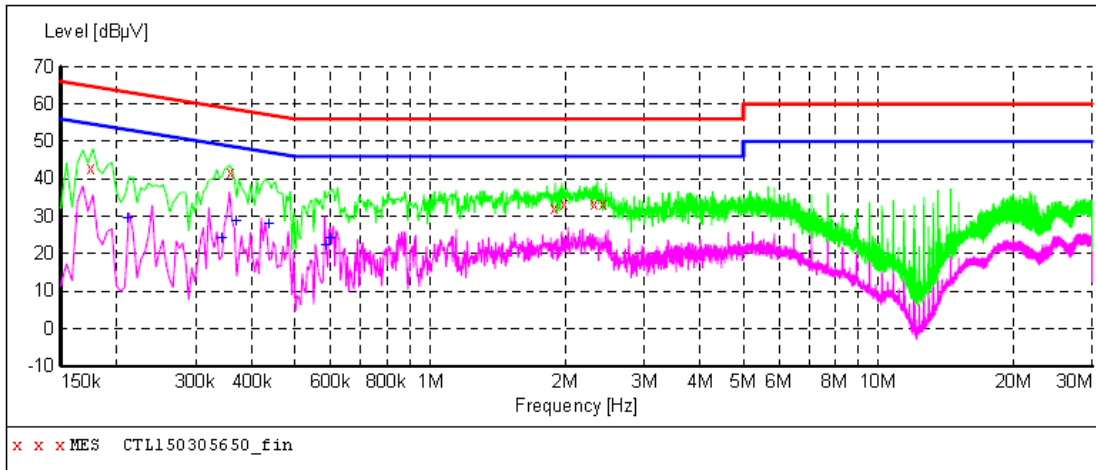

MEASUREMENT RESULT: "CTL150305650_fin"

3/5/2015 9:21AM

Frequency MHz	Level dBµV	Transd dB	Limit dBµV	Margin dB	Detector	Line	PE
0.174000	42.80	10.2	65	22.0	QP	L1	GND
0.358000	41.70	10.2	59	17.1	QP	L1	GND
1.886000	32.20	10.3	56	23.8	QP	L1	GND
1.988000	33.30	10.3	56	22.7	QP	L1	GND
2.318000	33.40	10.4	56	22.6	QP	L1	GND
2.426000	33.30	10.4	56	22.7	QP	L1	GND

MEASUREMENT RESULT: "CTL150305650_fin2"

3/5/2015 9:21AM

Frequency MHz	Level dBµV	Transd dB	Limit dBµV	Margin dB	Detector	Line	PE
0.210000	29.50	10.2	53	23.7	AV	L1	GND
0.342000	24.30	10.2	49	24.9	AV	L1	GND
0.366000	29.00	10.2	49	19.6	AV	L1	GND
0.434000	27.90	10.2	47	19.3	AV	L1	GND
0.584000	22.50	10.2	46	23.5	AV	L1	GND
0.596000	24.10	10.2	46	21.9	AV	L1	GND

Conducted Emission Test Data

EUT: Accent 1400
 Operating Condition: Normal Operation
 Test Site: Shielded Room
 Operator: Andy
 Test Specification: AC/DC adapter (AC 120V/60Hz)
 Comment: Neutral Line

SCAN TABLE: "Voltage (9K-30M) FIN"
 Short Description: 150K-30M Voltage

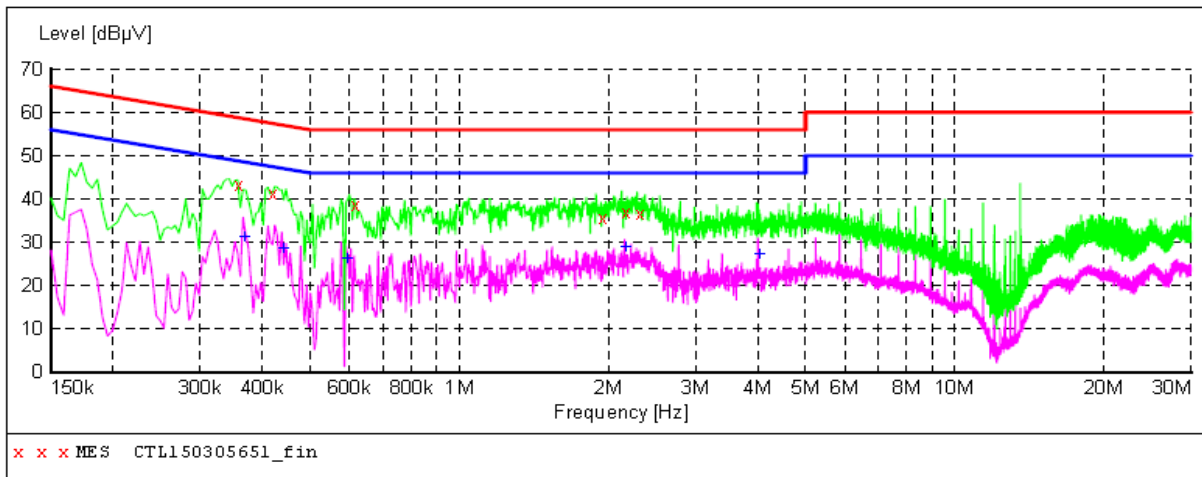

MEASUREMENT RESULT: "CTL150305651_fin"

3/5/2015 9:25AM

Frequency MHz	Level dBµV	Transd dB	Limit dBµV	Margin dB	Detector	Line	PE
0.358000	43.30	10.2	59	15.5	QP	N	GND
0.418000	41.10	10.2	58	16.4	QP	N	GND
0.614000	38.50	10.2	56	17.5	QP	N	GND
1.934000	35.50	10.3	56	20.5	QP	N	GND
2.162000	36.90	10.4	56	19.1	QP	N	GND
2.306000	36.50	10.4	56	19.5	QP	N	GND

MEASUREMENT RESULT: "CTL150305651_fin2"

3/5/2015 9:25AM

Frequency MHz	Level dBµV	Transd dB	Limit dBµV	Margin dB	Detector	Line	PE
0.366000	31.30	10.2	49	17.3	AV	N	GND
0.438000	28.80	10.2	47	18.3	AV	N	GND
0.590000	26.30	10.2	46	19.7	AV	N	GND
2.162000	29.10	10.4	46	16.9	AV	N	GND
4.010000	27.30	10.4	46	18.7	AV	N	GND

5. Test of Radiated Emission

5.1 Applicable Standard

Section 15.225 (a) The field strength of any emissions within the band 13.553-13.567 MHz shall not exceed 15,848 microvolts/meter at 30 meters.

Section 15.225 (b) Within the bands 13.410-13.553 MHz and 13.567-13.710 MHz, the field strength of any emissions shall not exceed 334 microvolts/meter at 30 meters.

Section 15.225 (c) Within the bands 13.110-13.410 MHz and 13.710-14.010 MHz the field strength of any emissions shall not exceed 106 microvolts/meter at 30 meters.

Section 15.225 (d) The field strength of any emissions appearing outside of the 13.110-14.010 MHz band shall not exceed the general radiated emission limits in § 15.209.

5.2 Limit of Radiated Disturbances

Except as provided elsewhere in this Subpart, the emissions from an intentional radiator shall not exceed the field strength levels specified in the following table:

Frequency (MHz)	Field strength @30m (uV/m)	Field strength @30m (dBuV/m)	Field strength @3m (dBuV/m)
Below 13.110	30	29.5	69.5
13.110 ~13.410	106	40.5	80.5
13.410~13.553	334	50.5	90.5
13.553~13.567	15,848	84	124
13.567~13.710	334	50.5	90.5
13.710~14.010	106	40.5	80.5
Above 14.010	30	29.5	69.5

Note:

(1) The tighter limit shall apply at the edge between two frequency bands.

(2) $\text{dBuV/m} = 20 \cdot \log(\text{uV/m})$

(3) Distance factor = 40dB / decade(15.31(f))

FCC Part15, Subpart C Section 15.209 limit of radiated emission for frequency below1000MHz. The emissions from an intentional radiator shall not exceed the field strength levels specified in the following table:

Frequency (MHz)	Distance (Meters)	Field Strengths Limits (dBμV/m)
0.009 -0.490	300	2400/F(KHz)
0.490 -1.705	30	24000/F(KHz)
1.705 -30	30	30
30 -88	3	40.0
88 -216	3	43.5
216 -960	3	46.0
Above 960	3	54.0

Note:

(1) The tighter limit shall apply at the edge between two frequency bands.

(2) Distance refers to the distance in meters between the test instrument antenna and the closest point of any part of the E.U.T.

5.3 EUT Setup

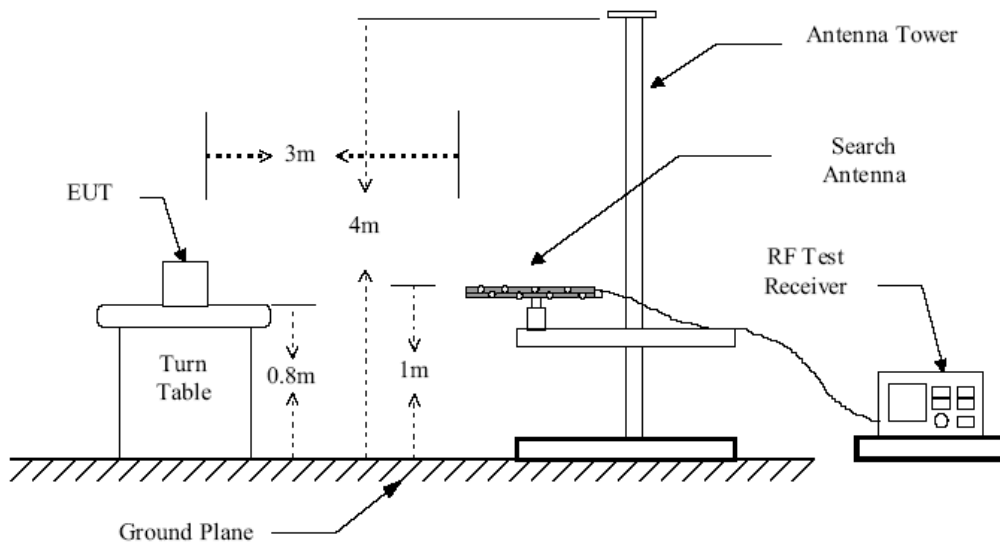
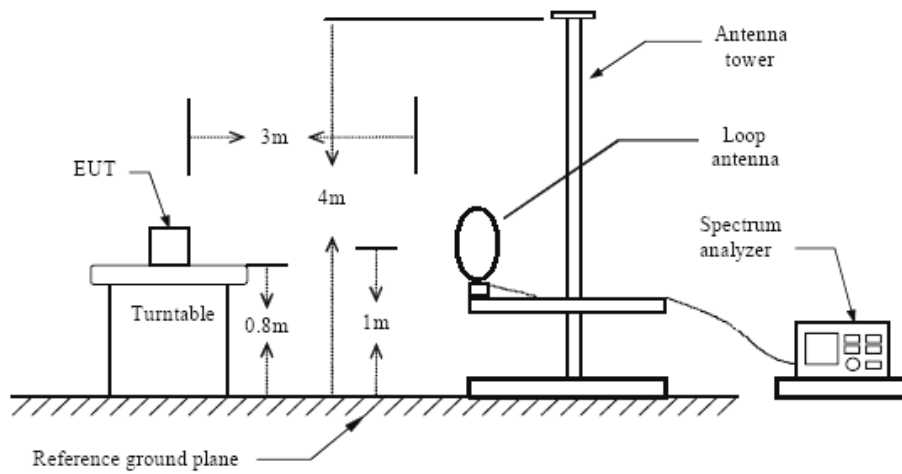

Figure 1 : Frequencies measured below 1 GHz configuration

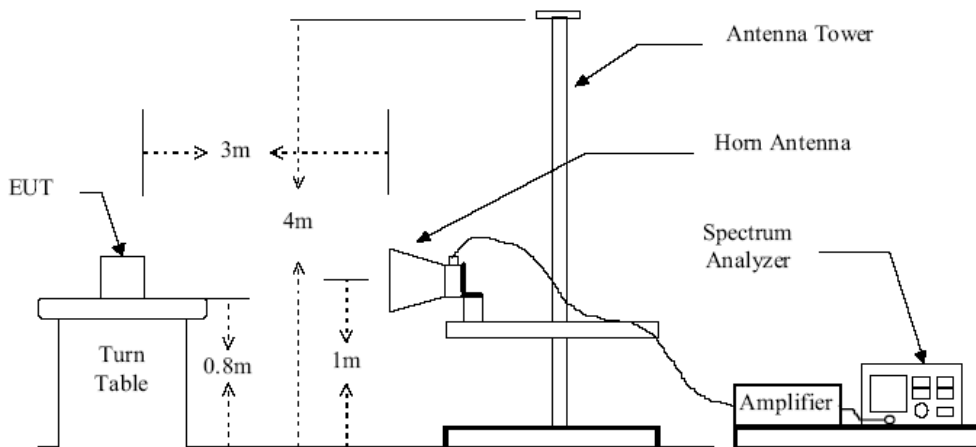

Figure 2 : Frequencies measured above 1 GHz configuration

5.4 Test Equipment List and Details

See section 2.5.

5.5 Test Procedure

1. Configure the EUT according to ANSI C63.4-2003
2. The EUT was placed on the top of the turntable 0.8 meter above ground.
3. Receiving antenna mounted on the top of a height-variable antenna tower was placed 3 meters far away from the turntable. When the frequency spectrum measured started from 9 kHz to 30 MHz, a loop antenna is used. When the frequency spectrum measured started from 30 MHz to 1000 MHz or above 1000 MHz, a broadband receiving antenna or the horn antenna are used.
4. Power on the EUT and all the supporting units.
5. The turntable was rotated by 360 degrees to determine the position of the highest radiation.
6. The height of the receiving antenna was varied between one meter and four meters above ground to find the maximum emission field strength of both horizontal and vertical polarization.
7. For each suspected emission, the antenna tower was scanned (from 1 M to 4 M) and then the turntable was rotated (from 0 degree to 360 degrees) to find the maximum reading.
8. Set the test-receiver system to Peak, CISPR quasi-peak or Average detect function with specified bandwidth according to different frequency spectrum measured under Maximum Hold Mode.

5.6 Test Result

Temperature (°C) : 22~23	EUT: Accent 1400
Humidity (%RH) : 50~54	M/N: ACN1400
Barometric Pressure (mbar) : 950~1000	Operation Condition: Tx Mode

NOTE:

In this testing, the EUT was respectively tested in three different orientations. That is:

- (1) EUT was lie vertically, and then its Antenna oriented upward
- (2) EUT was lie vertically, and then its Antenna oriented downward
- (3) EUT was lie flatwise, and then its Antenna oriented to the receiving antenna

The worst test data see following pages When the EUT was lie vertically, and then its Antenna oriented upward, the worst test data was got as following table.

WORST-CASE RADIATED EMISSION BELOW 30 MHz

Frequency	Meter Reading	Polar	Antenna Factor	Cable Loss	Emission Levels	Limits at 3m	Margin	Detector Mode
(MHz)	(dB μ V)	H/V	(dB/m)	(dB)	(dB μ V/m)	(dB μ V/m)	(dB)	QP /AV
13.56	84.58	V	10.75	1.34	47.53	124	-76.47	QP
13.553	18.75	V	10.34	1.34	31.78	70	-38.22	QP
13.557	19.65	V	10.34	1.35	32.45	70	-37.55	QP
21.45	21.08	V	8.66	1.08	29.98	49.5	-19.52	QP
25.43	23.66	V	7.49	1.66	34.75	49.5	-14.75	QP

Remark:

1. Data of measurement within this frequency range shown “ - ” in the table above means the reading of emissions are attenuated more than 20dB below the permissible limits or the field strength is too small to be measured.
2. The test limit distance is 3m limit.
3. PK means Peak Value, QP means Quasi Peak Value, AV means Average Value.

Radiated Emission Test Data Below 1G:

EUT: Accent 1400
M/N: ACN1400
Operating Condition: Tx Mode
Test Site: 3m CHAMBER
Operator: Chen
Test Specification: AC 120V/60Hz
Comment: Polarization: Horizontal

SWEEP TABLE: "test (30M-1G)"

Short Description:		Field Strength			
Start	Stop	Detector	Meas. Time	IF Bandw.	Transducer
Frequency	Frequency	MaxPeak			
30.0 MHz	1.0 GHz		300.0 ms	120 kHz	JB1

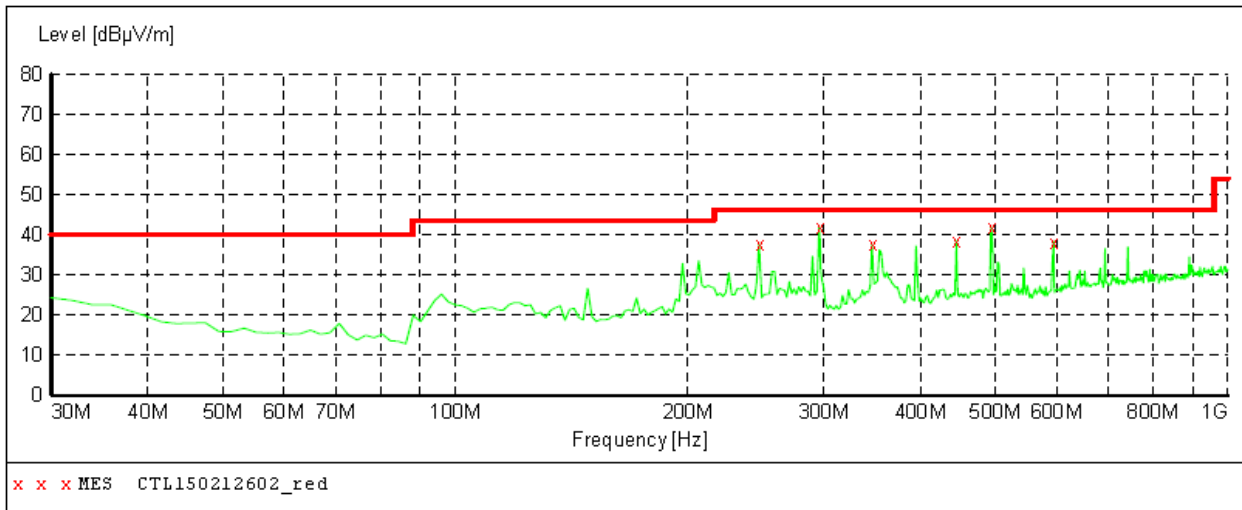

MEASUREMENT RESULT: "CTL150212602_red"

2/12/2015 9:16AM

Frequency MHz	Level dBµV/m	Transd dB	Limit dBµV/m	Margin dB	Det.	Height cm	Azimuth deg	Polarization
247.280000	37.70	14.1	46.0	8.3	---	0.0	0.00	HORIZONTAL
295.780000	42.00	15.4	46.0	4.0	---	0.0	0.00	HORIZONTAL
346.220000	37.60	16.8	46.0	8.4	---	0.0	0.00	HORIZONTAL
445.160000	38.40	19.2	46.0	7.6	---	0.0	0.00	HORIZONTAL
493.660000	41.90	20.3	46.0	4.1	---	0.0	0.00	HORIZONTAL
594.540000	38.20	21.7	46.0	7.8	---	0.0	0.00	HORIZONTAL

Radiated Emission Test Data Below 1G:

EUT: Accent 1400
M/N: ACN1400
Operating Condition: Tx Mode
Test Site: 3m CHAMBER
Operator: Chen
Test Specification: AC 120V/60Hz
Comment: Polarization: Vertical

SWEEP TABLE: "test (30M-1G) "

Short Description:		Field Strength			
Start	Stop	Detector	Meas. Time	IF Bandw.	Transducer
Frequency	Frequency	MaxPeak	300.0 ms	120 kHz	JB1
30.0 MHz	1.0 GHz				

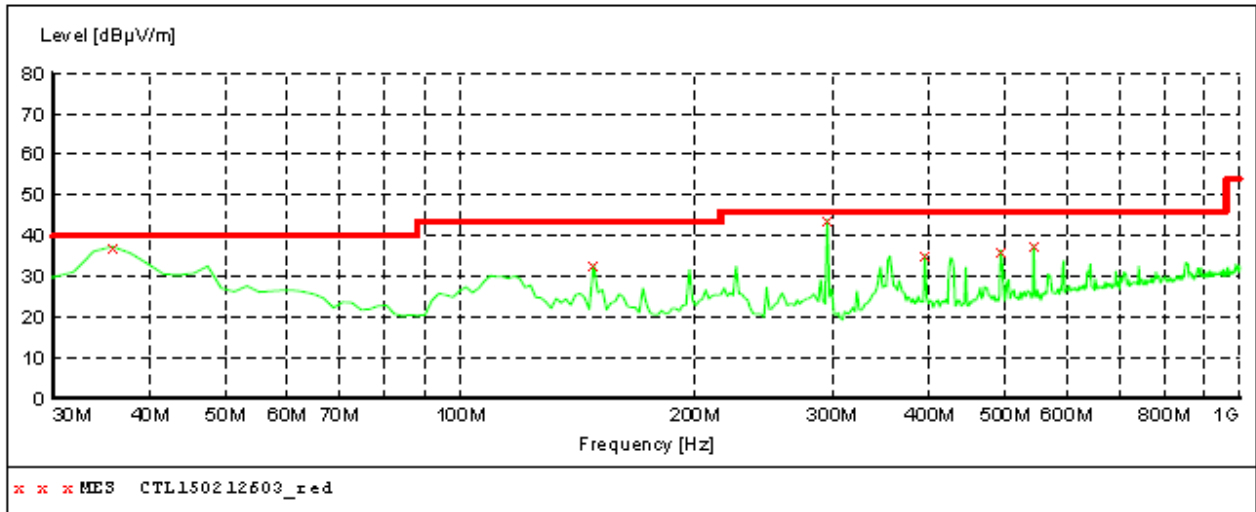

MEASUREMENT RESULT: "CTL150212603_red"

2/12/2015 9:18AM

Frequency MHz	Level dBµV/r	Transd dB	Limit dBµV/r	Margin dB	Det.	Height cr	Azimuth deg	Polarization
35.820000	37.30	16.7	40.0	2.7	---	0.0	0.00	VERTICAL
148.340000	32.80	14.2	43.5	10.7	---	0.0	0.00	VERTICAL
295.780000	43.90	15.4	46.0	2.1	---	0.0	0.00	VERTICAL
394.720000	35.30	18.0	46.0	10.7	---	0.0	0.00	VERTICAL
493.660000	36.40	20.3	46.0	9.6	---	0.0	0.00	VERTICAL
544.100000	37.60	20.9	46.0	8.4	---	0.0	0.00	VERTICAL

6. Frequency Tolerance

6.1 Applicable Standard

Section 15.225(e): The frequency tolerance of the carrier signal shall be maintained within +/- 0.01% of the operating frequency over a temperature variation of -20 degrees to +50 degrees C at normal supply voltage, and for a variation in the primary supply voltage from 85% to 115% of the rated supply voltage at a temperature of 20 degrees C. For battery operated equipment, the equipment tests shall be performed using a new battery.

6.2 EUT Setup

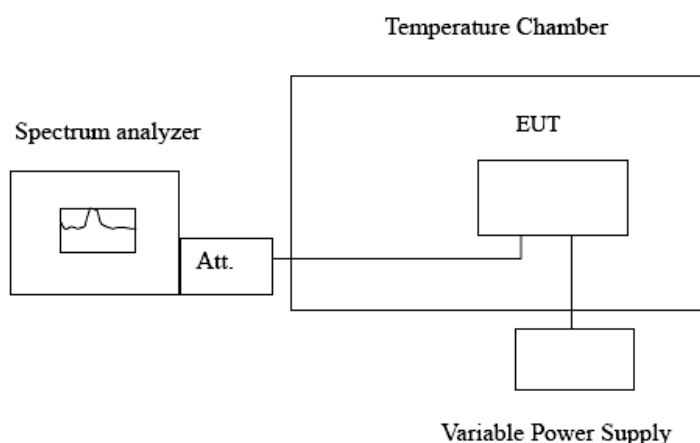

6.3 Test Equipment List and Details

See section 2.5.

6.4 Test Procedure

The frequency stability of the transmitter is measured by:

- (a) Temperature: The temperature is varied from -20 to $^{\circ}\text{C}$ +50 $^{\circ}\text{C}$ using an environmental chamber.
- (b) Primary Supply Voltage: The primary supply voltage is varied from 85% to 115% of the voltage normally input to the device or at the power supply terminals if cables are not normally supplied.

The frequency tolerance of the carrier shall be maintained within $\pm 0.01\%$ of the operating frequency.

6.5 Test Result

Temperature ($^{\circ}\text{C}$) : 22~23	EUT: Accent 1400
Humidity (%RH) : 50~54	M/N: ACN1400
Barometric Pressure (mbar) : 950~1000	Operation Condition: Tx Mode

Voltage (%)	Power (VDC)	Temperature (°C)	Frequency (MHz)	Deviation (%)
100	120	+20°C (Ref)	13.559573	0.0031490
100	120	-20	13.559689	0.0022935
100	120	-10	13.559674	0.0024041
100	120	0	13.559653	0.0025590
100	120	10	13.559622	0.0027876
100	120	25	13.559585	0.0030605
100	120	30	13.559558	0.0032596
100	120	40	13.559547	0.0033407
100	120	50	13.559552	0.0033038
85	102	20	13.559576	0.0031268
115	138	20	13.559594	0.0029941

7. ANTENNA REQUIREMENT

7.1 Standard Applicable

Section 15.203:

An intentional radiator shall be designed to ensure that no antenna other than that furnished by the responsible party shall be used with the device. The use of a permanently attached antenna or of an antenna that uses a unique coupling to the intentional radiator shall be considered sufficient to comply with the provisions of this Section. The manufacturer may design the unit so that a broken antenna can be replaced by the user, but the use of a standard antenna jack or electrical connector is prohibited.

7.2 Antenna Connected Construction

The antenna connector is designed with permanent attachment and no consideration of replacement. The antenna used in this product is complied with Standard. The maximum Gain of the antenna lower than 6.0dBi and have the definite antenna Specification.