

FCC PART 15 SUBPART B
MEASUREMENT AND TEST REPORT

For

Prentke Romich Company

1022 Heyl Rd. Wooster, Ohio 44691

MODEL: ACN1000

August 24, 2015

This Report Concerns: <input checked="" type="checkbox"/> Original Report	Equipment Type: Accent 1000
Test By:	Kare Gao / <i>Kare Gao</i>
Report Number:	QCT15GR035E
Test Date:	August 21, 2015
Reviewed By:	Carmi Du / <i>Carmi Du</i>
Approved By:	Kend Wang / <i>Kendy Wang</i>
Prepared By:	Shenzhen QC Testing Laboratory Co., Ltd. 1st Floor, Building A, Huawan Industrial Park, Gushu, Xixiang Street, Baoan, 518126, Shenzhen, China Tel: 0755-23008269 Fax: 0755-23726780

TABLE OF CONTENTS

1 - GENERAL INFORMATION	3
1.1 PRODUCT DESCRIPTION FOR EQUIPMENT UNDER TEST (EUT)	3
1.2 TEST STANDARDS	3
1.3 TEST SUMMARY	3
1.4 TEST METHODOLOGY	4
1.5 TEST FACILITY	4
2 - SYSTEM TEST CONFIGURATION	5
2.1 JUSTIFICATION	5
2.2 EUT EXERCISE SOFTWARE	5
2.3 SPECIAL ACCESSORIES	5
2.4 EQUIPMENT MODIFICATIONS	5
2.5 CONFIGURATION OF TEST SYSTEM	5
3 - DISTURBANCE VOLTAGE AT THE MAINS TERMINALS	7
3.1 MEASUREMENT UNCERTAINTY	7
3.2 LIMIT OF DISTURBANCE VOLTAGE AT THE MAINS TERMINALS	7
3.3 EUT SETUP	7
3.4 INSTRUMENT SETUP	8
3.5 TEST PROCEDURE	8
3.6 SUMMARY OF TEST RESULTS	8
3.7 DISTURBANCE VOLTAGE TEST DATA	8
3.8 TEST EQUIPMENT LIST AND DETAILS	8
3.9 TEST RESULT	8
4 - RADIATED DISTURBANCES	11
4.1 MEASUREMENT UNCERTAINTY	11
4.2 LIMIT OF RADIATED DISTURBANCES	11
4.3 EUT SETUP	11
4.4 TEST RECEIVER SETUP	12
4.5 TEST PROCEDURE	12
4.6 CORRECTED AMPLITUDE & MARGIN CALCULATION	12
4.7 RADIATED EMISSIONS TEST RESULT	12
4.8 TEST EQUIPMENT LIST AND DETAILS	13
4.9 TEST RESULT	13

1 - GENERAL INFORMATION

1.1 Product Description for Equipment Under Test (EUT)

Client Information

Applicant: **Prentke Romich Company**
Address of applicant: 1022 Heyl Rd. Wooster, Ohio 44691
Manufacturer: **Prentke Romich Company**
Address of manufacturer: 1022 Heyl Rd. Wooster, Ohio 44691

General Description of E.U.T

EUT Description: **Accent 1000**
Model No.: **ACN1000**
Brand Name: **Accent™ 1000**
Power Rating: 7.4VDC from battery, AC 120V/60Hz for adapter.
Adapter Information:
Model No: MENB1060A1800N02;
Manufacturer: SL POWER and AULT
Input: 100-240V~ 50-60Hz 1.5A Max ; Output: 18.0V 3.4A

Remark: * The test data gathered are from the production sample provided by the manufacturer.

1.2 Test Standards

The following Declaration of Conformity report of EUT is prepared in accordance with FCC Rules and Regulations Part 15 Subpart B

The objective of the manufacturer is to demonstrate compliance with the described above standards.

1.3 Test Summary

For the EUT described above. The standards used were FCC Part 15 Subpart B for Emissions

Table 1 : Tests Carried Out Under FCC Part 15 Subpart B

Standard	Test Items	Status
FCC Part 15 Subpart B	Conduction Emission, 0.15MHz to 30MHz	√
FCC Part 15 Subpart B	Radiation Emission, 30MHz to 1GHz	√
FCC Part 15 Subpart B	Radiation Emission, Above 1GHz	√

- √ Indicates that the test is applicable
× Indicates that the test is not applicable

1.4 Test Methodology

All measurements contained in this report were conducted with CISPR 16-1-1: 2006, radio disturbance and immunity measuring apparatus, and CISPR 16-2-3: 2010, Method of measurement of disturbances and immunity. All measurement required was performed at Shenzhen CTL Testing Technology Co., Ltd. at Floor 1-A, Baisha Technology Park, No.3011, Shahexi Road, Nanshan District, Shenzhen, China 518055

1.5 Test Facility

The test facility is recognized, certified, or accredited by the following organizations:

CNAS – Registration No.: L5540

Shenzhen CTL Testing Technology Co., Ltd. To ISO/IEC 17025:25 General Requirements for the Competence of Testing and Calibration Laboratories(CNAS-CL01 Accreditation Criteria for the Competence of Testing and Calibration Laboratories) for the competence in the field of testing.The acceptance letter from the CNAS is maintained in our files: Registration: L5540, March, 2012.

FCC – Registration No.: 970318

Shenzhen CTL Testing Technology Co., Ltd. EMC Laboratory has been Registered and fully described in a report filed with the (FCC) Federal Communications Commission. The acceptance letter from the FCC is maintained in our files. Registration:970318, December 19, 2013.

2 - SYSTEM TEST CONFIGURATION

2.1 Justification

The system was configured for testing in a typical fashion (as only used by a typical user).

2.2 EUT Exercise Software

The EUT exercising program used during radiated and conducted testing was designed to exercise the various system components in a manner similar to a typical use. The software offered by manufacture, can let the EUT being ON operation.

2.3 Special Accessories

As shown in section 2.5, interface cable used for compliance testing is shielded as normally supplied by Prentke Romich Company and its respective support equipment manufacturers.

2.4 Equipment Modifications

The EUT tested was not modified by QCT.

2.5 Configuration of Test System

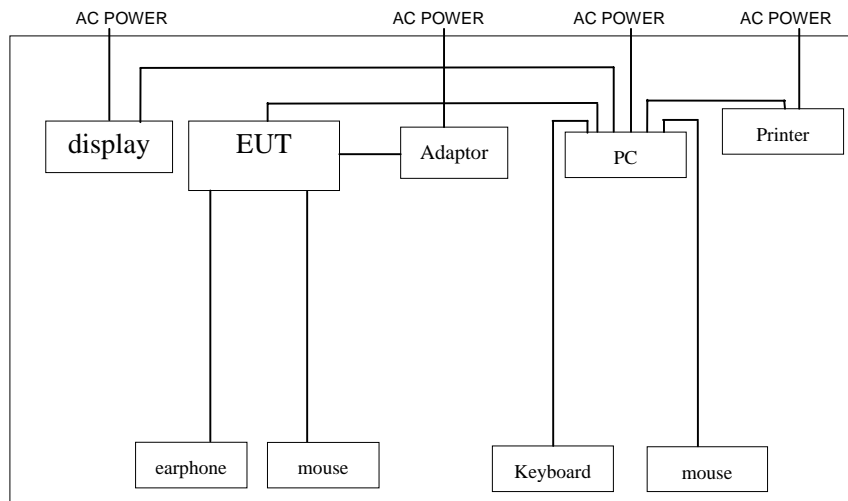

General Description of Test Auxiliary Equipment:

AUX Description:	Manufacturer	Model No.	Serial No.	Certificate	Cable
Monitor	viewsonic	VS15323	TP6140301 192	CE, FCC	HDMI Cable 1.2m Shield with Two Core
Mouse	lenovo	mogouo	0A3610144 F2DGL1420	CE, FCC	1.0m unshield
Mouse	lenovo	mogouo	0A3610144 F2DGL1420	CE, FCC	1.0m unshield
Keyboard	DELL	SK-8115	3845C85	CE, FCC	1.2m shield
PC	HP	HPE- 355cn	18CK4513	CE, FCC	N/A
Printer	Canon	IP2780	JN865C89	CE, FCC	USB Cable 1.2m Shield with Two Core
Earphone	lenovo	385	N/A	CE, FCC	1.2m unshield

3 - DISTURBANCE VOLTAGE AT THE MAINS TERMINALS

3.1 Measurement Uncertainty

All measurements involve certain levels of uncertainties, especially in field of EMC. The factors contributing to uncertainties are spectrum analyzer, cable loss, and LISN.

The Treatment of Uncertainty in EMC Measurements, the best estimate of the uncertainty of any conducted emissions measurement is ± 3.1 dB.

3.2 Limit of Disturbance Voltage at The Mains Terminals

Frequency Range (MHz)	Limits (dBuV)	
	Quasi-Peak	Average
0.150~0.500	66~56	56~46
0.500~5.000	56	46
5.000~30.00	60	50

Note: (1)The tighter limit shall apply at the edge between two frequency bands.

3.3 EUT Setup

The setup of EUT is according with ANSI C63.4-2009 measurement procedure. The specification used was the FCC Rules and Regulations Part 15 Subpart B limits.

The EUT was placed center and the back edge of the test table.

The AV cables were draped along the test table and bundled to 30-40cm in the middle.

The spacing between the peripherals was 10 cm.

Maximum emission emitted from EUT was determined by manipulating the EUT, support equipment, interconnecting cables and varying the mode of operation and the levels in the final result of the test were recorded with the EUT running in the operating mode that maximum emission was emitted.

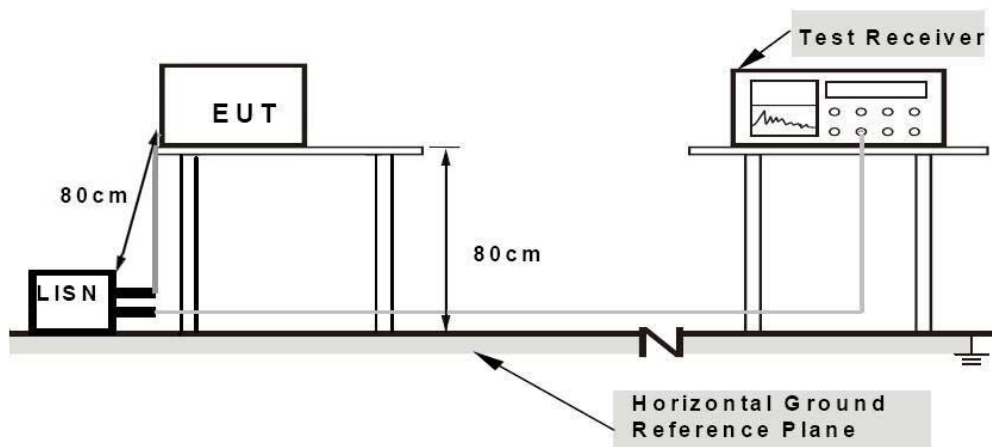

3.4 Instrument Setup

The test receiver was set with the following configurations:

Test Receiver Setting:

Frequency Range.....150 KHz to 30 MHz
 Detector.....Peak & Quasi-Peak & Average
 Sweep Speed.....Auto
 IF Band Width.....9 KHz

3.5 Test Procedure

During the conducted emission test, the EUT power cord was connected to the auxiliary outlet of the first Artificial Mains.

Maximizing procedure was performed on the six (6) highest emissions to ensure EUT compliance using all installation combination.

All data was recorded in the peak detection mode. Quasi-peak and Average readings were only performed when an emission was found to be marginal (within -10 dB μ V of specification limits). Quasi-peak readings are distinguished with a "QP". Average readings are distinguished with a "AV".

3.6 Summary of Test Results

According to the data in section 3.6, the EUT complied with the FCC Part 15 B Conducted margin, with the *worst* margin reading of:

3.7 Disturbance Voltage Test Data

Temperature (°C)	22~25
Humidity (%RH)	50~55
Barometric Pressure (mbar)	950~1000
EUT	Accent 1000
M/N	ACN1000
Operating Mode	ON

Test data see following pages

- Remark:** (1) When PK reading is less than relevant limit 20dB, the QP reading and AV reading will not be recorded.
 (2) Where QP reading is less than relevant AV limit, the AV reading will not be measured
 (3) The worst test data see following pages

3.8 Test Equipment List and Details

Item	Test Equipment	Manufacturer	Model No.	Serial No.	Last Cal.
1	EMI TEST RECEIVER	ROHDE & SCHWARZ	ESCI	1166.5950.03	2015.03.19
2	Teo Line Single Phase Module	R&S	ESH2-Z5	100393	2015.03.19

3.9 Test Result

PASS

Conducted Emission Test Data

EUT: Accent 1000
M/N: ACN1000
Operating Condition: ON
Test Site: Shielded Room
Operator: Cheng
Test Specification: AC 120V/60Hz
Comment: Live Line
Start of Test: Tem:25°C Hum:50%

SCAN TABLE: "Voltage (9K-30M)FIN"
Short Description: 150K-30M Voltage

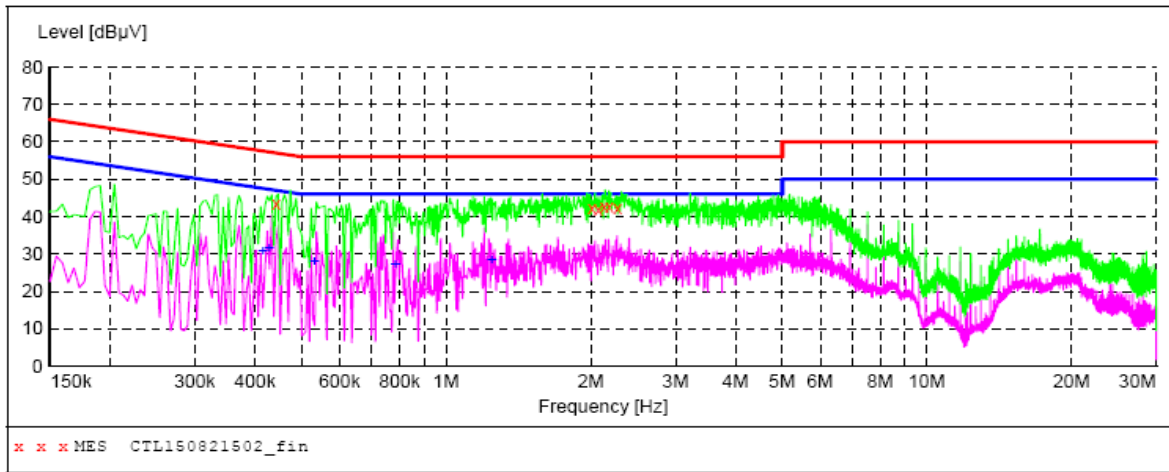

MEASUREMENT RESULT: "CTL150821502_fin"

8/21/2015 9:15AM

Frequency MHz	Level dBµV	Transd dB	Limit dBµV	Margin dB	Detector	Line	PE
0.442501	43.60	10.2	57	13.4	QP	L1	GND
2.008501	42.10	10.4	56	13.9	QP	L1	GND
2.071501	42.00	10.4	56	14.0	QP	L1	GND
2.130001	42.50	10.4	56	13.5	QP	L1	GND
2.184001	42.60	10.4	56	13.4	QP	L1	GND
2.269501	42.30	10.4	56	13.7	QP	L1	GND

MEASUREMENT RESULT: "CTL150821502_fin2"

8/21/2015 9:15AM

Frequency MHz	Level dBµV	Transd dB	Limit dBµV	Margin dB	Detector	Line	PE
0.415501	30.70	10.2	48	16.8	AV	L1	GND
0.429001	31.50	10.2	47	15.8	AV	L1	GND
0.532501	28.10	10.2	46	17.9	AV	L1	GND
0.784501	27.10	10.2	46	18.9	AV	L1	GND
1.243501	28.20	10.3	46	17.8	AV	L1	GND

Conducted Emission Test Data

EUT: Accent 1000
M/N: ACN1000
Operating Condition: ON
Test Site: Shielded Room
Operator: Cheng
Test Specification: AC 120V/60Hz
Comment: Neutral Line
Start of Test: Tem:25°C Hum:50%

SCAN TABLE: "Voltage (9K-30M)FIN"
Short Description: 150K-30M Voltage

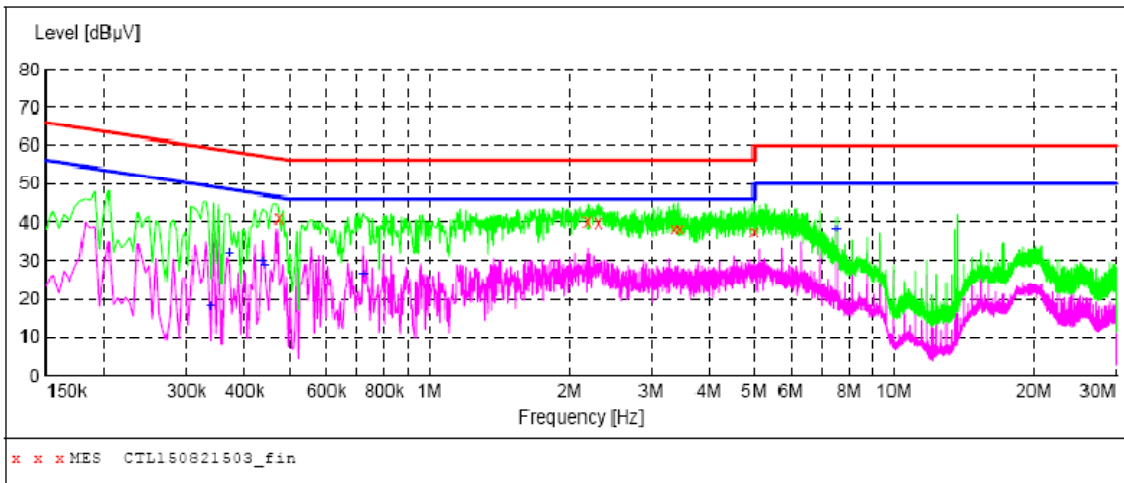

MEASUREMENT RESULT: "CTL150821503_fin"

8/21/2015 9:18AM

Frequency MHz	Level dBµV	Transd dB	Limit dBµV	Margin dB	Detector	Line	PE
0.474001	41.10	10.2	56	15.3	QP	N	GND
2.184001	40.20	10.4	56	15.8	QP	N	GND
2.310001	39.70	10.4	56	16.3	QP	N	GND
3.363001	38.10	10.4	56	17.9	QP	N	GND
3.453001	38.20	10.4	56	17.8	QP	N	GND
4.987501	37.60	10.4	56	18.4	QP	N	GND

MEASUREMENT RESULT: "CTL150821503_fin2"

8/21/2015 9:18AM

Frequency MHz	Level dBµV	Transd dB	Limit dBµV	Margin dB	Detector	Line	PE
0.339001	18.10	10.2	49	31.1	AV	N	GND
0.370501	31.90	10.2	49	16.6	AV	N	GND
0.438001	30.10	10.2	47	17.0	AV	N	GND
0.442501	28.60	10.2	47	18.4	AV	N	GND
0.721501	26.30	10.2	46	19.7	AV	N	GND
7.525501	38.40	10.5	50	11.6	AV	N	GND

4 - RADIATED DISTURBANCES

4.1 Measurement Uncertainty

All measurements involve certain levels of uncertainties, especially in field of EMC. The factors contributing to uncertainties are spectrum analyzer, cable loss, antenna factor calibration, antenna directivity, antenna factor variation with height, antenna phase center variation, antenna factor frequency interpolation, measurement distance variation, site imperfections, mismatch (average), and system repeatability.

The Treatment of Uncertainty in EMC Measurements, the best estimate of the uncertainty of a radiation emissions measurement is ± 3.4 dB.

4.2 Limit of Radiated Disturbances

Below 1GHz:

Frequency (MHz)	Distance (Meters)	Field Strengths Limits (dB μ V/m)
30 ~ 88	3	40
88~216	3	43.5
216 ~ 960	3	46
960 ~ 1000	3	54

- Note: (1) The tighter limit shall apply at the edge between two frequency bands.
 (2) Distance refers to the distance in meters between the test instrument antenna and the closest point of any part of the E.U.T.

Above 1GHz:

Frequency (MHz)	Distance (Meters)	Field Strengths Limits (dB μ V/m)	
		Average	Peak
Above 1000	3	54	74

4.3 EUT Setup

The radiated emission tests were performed in the in the 3-meter anechoic chamber, using the setup accordance with the ANSI C63.4-2009. The specification used was the FCC Part 15 Subpart B limits.

The EUT was placed on the center of the test table.

Maximum emission emitted from EUT was determined by manipulating the EUT, support equipment, interconnecting cables and varying the mode of operation and the levels in the final result of the test were recorded with the EUT running in the operating mode that maximum emission was emitted.

Block diagram of test setup (In chamber)

Below 1 GHz

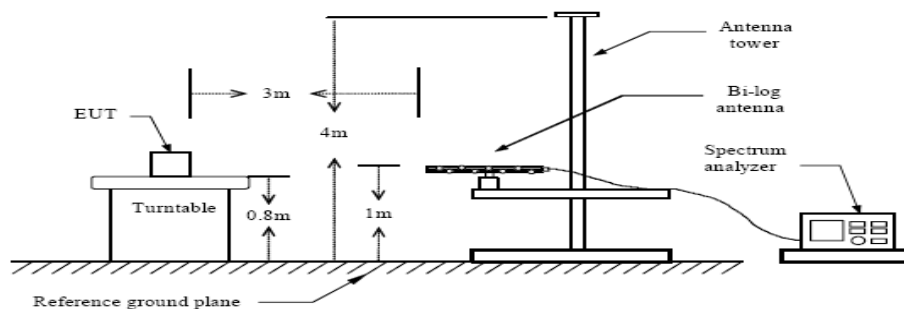

4.4 Test Receiver Setup

According to FCC Part 15 rule, the frequency was investigated from 30 to 1000 MHz. During the radiated emission test, the test receiver was set with the following configurations:

Test Receiver Setting:

Detector.....Peak & Quasi-Peak
IF Band Width.....120KHz
Frequency Range.....30MHz to 1000MHz
Turntable Rotated.....0 to 360 degrees

Antenna Position:

Height.....1m to 4m
Polarity.....Horizontal and Vertical

4.5 Test Procedure

Maximizing procedure was performed on the highest emissions to ensure that the EUT complied with all installation combinations.

All data was recorded in the peak detection mode. Quasi-peak readings performed only when an emission was found to be marginal (within -10 dB μ V of specification limits), and are distinguished with a "QP" in the data table.

4.6 Corrected Amplitude & Margin Calculation

The Corrected Amplitude is calculated by adding the Antenna Factor and Cable Factor, and subtracting the Amplifier Gain from the Amplitude reading. The basic equation is as follows:

$$\text{Corr. Ampl.} = \text{Indicated Reading} + \text{Antenna Factor} + \text{Cable Factor} - \text{Amplifier Gain}$$

The "**Margin**" column of the following data tables indicates the degree of compliance with the applicable limit. For example, a margin of -7dB μ V means the emission is 7dB μ V below the maximum limit for Subpart B. The equation for margin calculation is as follows:

$$\text{Margin} = \text{Limit} - \text{Corr. Ampl.}$$

4.7 Radiated Emissions Test Result

Temperature (°C)	22~25
Humidity (%RH)	50~54
Barometric Pressure (mbar)	950~1000
EUT	Accent 1000
M/N	ACN1000
Operating Mode	ON

Remark: The worst test data see following pages

4.8 Test Equipment List and Details

Item	Test Equipment	Manufacturer	Model No.	Serial No.	Last Cal.
1	ULTRA-BROADBAND ANTENNA	Sunol Sciences Corp.	JB1 Antenna	A061713	2015.05.22
2	EMI TEST RECEIVER	ROHDE & SCHWARZ	ESCI	1166.5950.03	2015.03.19
3	Amplifier	HP	8447D	1937A02492	2015.04.24
4	Broadband preamplifier	SCH WARZBECK	BBV9718	9718-182	2015.04.24
5	Horn antenna	SCHWARZBECK	BBHA9710	1562	2015.07.21

4.9 Test Result

PASS

Radiated Emission Test Data

EUT: Accent 1000
M/N: ACN1000
Operating Condition: HD Playing With HDMI Display
Test Site: CHAMBER
Operator: Pan
Test Specification: AC 120V/60Hz
Comment: Polarization: Horizontal
Start of Test: Tem:25°C Hum:50%

SWEEP TABLE: "test (30M-1G)"

Short Description:		Field Strength			
Start Frequency	Stop Frequency	Detector	Meas. Time	IF Bandw.	Transducer
30.0 MHz	1.0 GHz	MaxPeak	500.0 ms	100 kHz	VULB9168

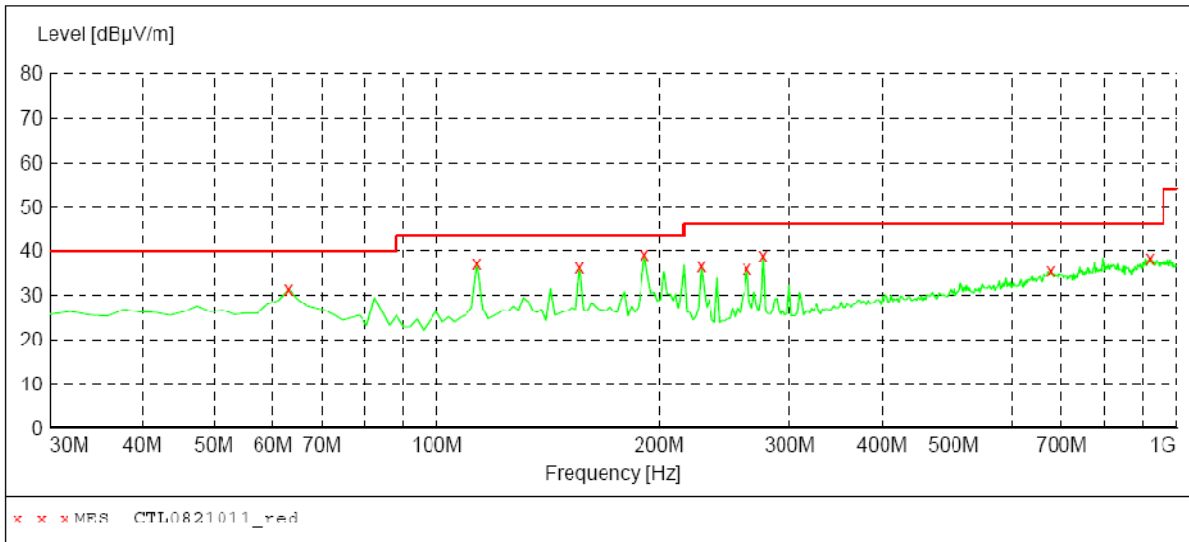

MEASUREMENT RESULT: "CTL0821011_red"

8/21/2015 2:27PM

Frequency MHz	Level dBµV/m	Transd dB	Limit dBµV/m	Margin dB	Det.	Height cm	Azimuth deg	Polarization
62.980000	31.40	12.8	40.0	8.6	QP	100.0	0.00	HORIZONTAL
113.420000	37.40	12.5	43.5	6.1	QP	200.0	0.00	HORIZONTAL
156.100000	36.40	15.3	43.5	7.1	QP	100.0	0.00	HORIZONTAL
191.020000	39.20	11.8	43.5	4.3	QP	100.0	0.00	HORIZONTAL
227.880000	36.70	12.6	46.0	9.3	QP	200.0	0.00	HORIZONTAL
262.800000	36.20	13.5	46.0	9.8	QP	200.0	0.00	HORIZONTAL
276.380000	39.00	13.9	46.0	7.0	QP	100.0	0.00	HORIZONTAL
676.020000	35.70	22.1	46.0	10.3	QP	100.0	0.00	HORIZONTAL
922.400000	38.50	25.0	46.0	7.5	QP	100.0	0.00	HORIZONTAL

Radiated Emission Test Data

EUT: Accent 1000
M/N: ACN1000
Operating Condition: HD Playing With HDMI Display
Test Site: CHAMBER
Operator: Pan
Test Specification: AC 120V/60Hz
Comment: Polarization: Vertical
Start of Test: Tem:25°C Hum:50%

SWEEP TABLE: "test (30M-1G)"

Short Description:		Field Strength			
Start	Stop	Detector	Meas. Time	IF Bandw.	Transducer
Frequency	Frequency				
30.0 MHz	1.0 GHz	MaxPeak	500.0 ms	100 kHz	VULB9168

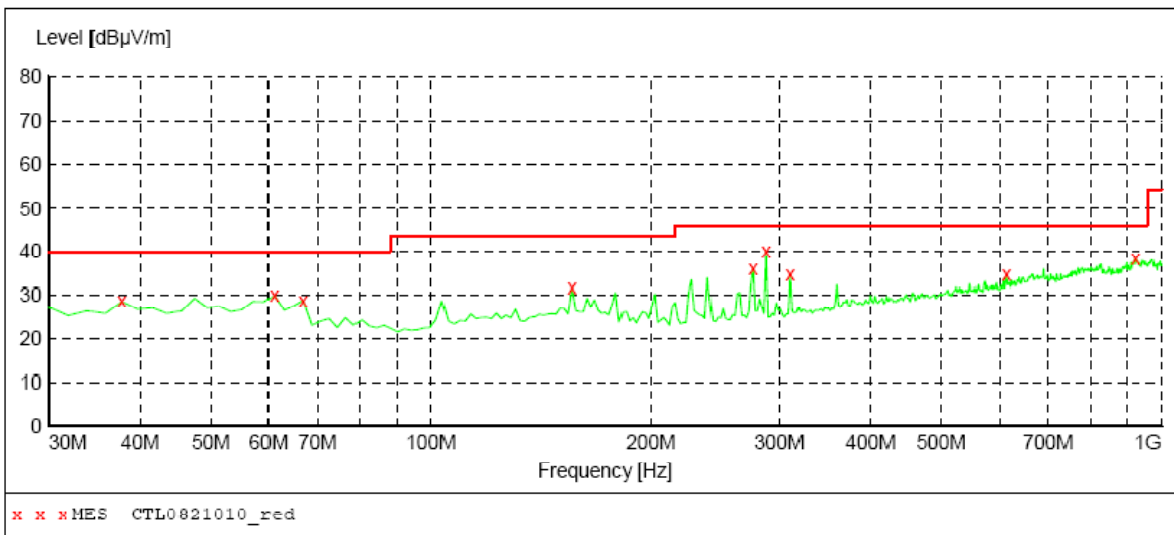

MEASUREMENT RESULT: "CTL0821010_red"

8/21/2015 2:24PM

Frequency MHz	Level dBµV/m	Transd dB	Limit dBµV/m	Margin dB	Det.	Height cm	Azimuth deg	Polarization
37.760000	28.60	14.3	40.0	11.4	QP	100.0	0.00	VERTICAL
61.040000	29.90	13.2	40.0	10.1	QP	100.0	0.00	VERTICAL
66.860000	28.90	12.1	40.0	11.1	QP	100.0	0.00	VERTICAL
156.100000	31.70	15.3	43.5	11.8	QP	100.0	0.00	VERTICAL
276.380000	36.10	13.9	46.0	9.9	QP	100.0	0.00	VERTICAL
288.020000	40.10	14.2	46.0	5.9	QP	100.0	0.00	VERTICAL
311.300000	34.80	14.8	46.0	11.2	QP	100.0	0.00	VERTICAL
613.940000	34.70	21.1	46.0	11.3	QP	100.0	0.00	VERTICAL
924.340000	38.50	25.0	46.0	7.5	QP	100.0	0.00	VERTICAL

Radiated Emission Test Data

EUT: Accent 1000
M/N: ACN1000
Operating Condition: HD Playing With HDMI Display
Test Site: CHAMBER
Operator: Pan
Test Specification: AC 120V/60Hz
Comment: Polarization: Horizontal
Start of Test: Tem:25°C Hum:50%

SWEEP TABLE: "test (1G-18G) P"

Short Description:		EN 55022 Field Strength			
Start	Stop	Detector	Meas. Time	IF Bandw.	Transducer
Frequency	Frequency				
1.0 GHz	6.0 GHz	MaxPeak	500.0 ms	1 MHz	DRH-118

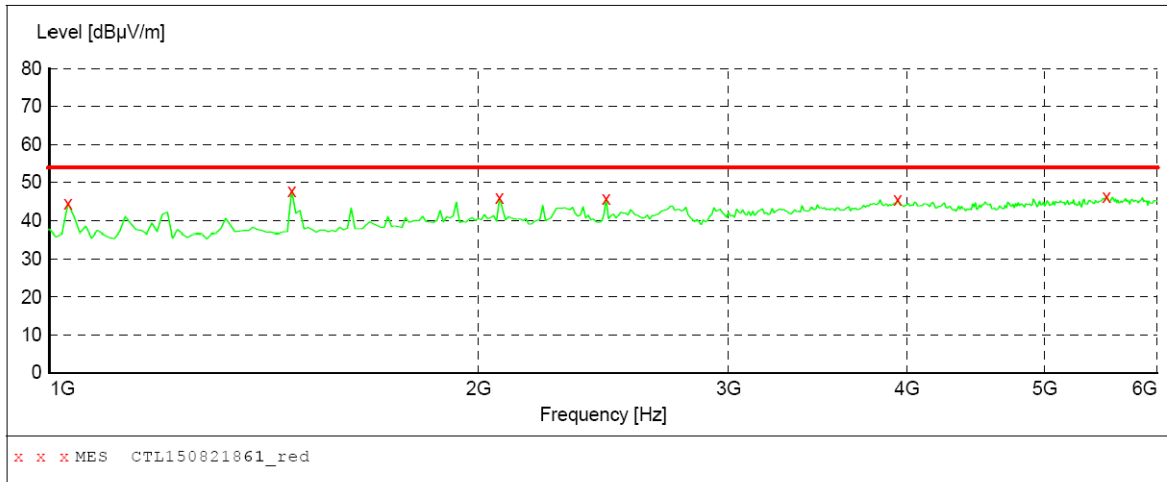

MEASUREMENT RESULT: "CTL150821861_red"

8/21/2015 11:45AM

Frequency MHz	Level dBµV/m	Transd dB	Limit dBµV/m	Margin dB	Det.	Height cm	Azimuth deg	Polarization
1030.000000	44.40	-12.3	74.0	29.6	PEAK	0.0	0.00	HORIZONTAL
1480.000000	47.90	-10.0	74.0	26.1	PEAK	0.0	0.00	HORIZONTAL
2070.000000	46.00	-6.8	74.0	28.0	PEAK	0.0	0.00	HORIZONTAL
2460.000000	45.70	-5.4	74.0	28.3	PEAK	0.0	0.00	HORIZONTAL
3940.000000	45.50	-0.7	74.0	28.5	PEAK	0.0	0.00	HORIZONTAL
5530.000000	46.20	0.8	74.0	27.8	PEAK	0.0	0.00	HORIZONTAL

Radiated Emission Test Data

EUT: Accent 1000
M/N: ACN1000
Operating Condition: HD Playing With HDMI Display
Test Site: CHAMBER
Operator: Pan
Test Specification: AC 120V/60Hz
Comment: Polarization: Vertical
Start of Test: Tem:25°C Hum:50%

SWEEP TABLE: "test (1G-18G) P"

Short Description: EN 55022 Field Strength
Start Stop Detector Meas. IF Transducer
Frequency Frequency Time Bandw.
1.0 GHz 6.0 GHz MaxPeak 500.0 ms 1 MHz DRH-118

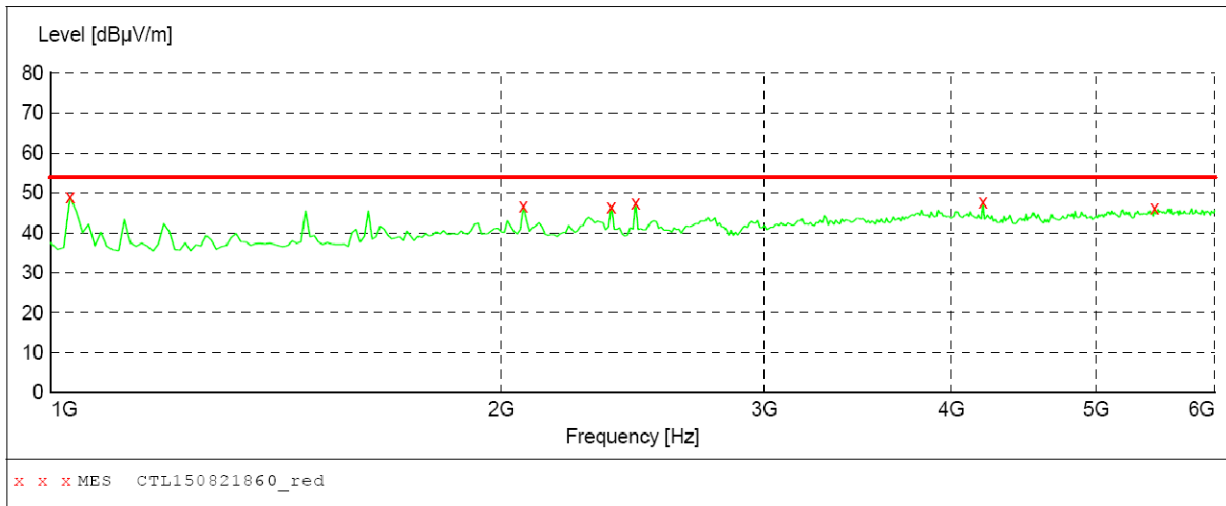

MEASUREMENT RESULT: "CTL150821860_red"

8/21/2015 11:44AM

Frequency MHz	Level dBµV/m	Transd dB	Limit dBµV/m	Margin dB	Det.	Height cm	Azimuth deg	Polarization
1030.000000	49.00	-12.3	74.0	25.0	PEAK	0.0	0.00	VERTICAL
2070.000000	46.70	-6.8	74.0	27.3	PEAK	0.0	0.00	VERTICAL
2370.000000	46.60	-5.5	74.0	27.4	PEAK	0.0	0.00	VERTICAL
2460.000000	47.40	-5.4	74.0	26.6	PEAK	0.0	0.00	VERTICAL
4200.000000	47.90	-1.4	74.0	26.1	PEAK	0.0	0.00	VERTICAL
5170.000000	46.30	0.6	74.0	27.7	PEAK	0.0	0.00	VERTICAL