

Test Report of FCC CFR 47 Part 15 Subpart C

On Behalf of

Prentke Romich Company

FCC ID: 2AD9PACN1000

Product Description: Accent 1000

Model No.: ACN1000

Supplementary Model: N/A

Prepared for: Prentke Romich Company

1022 Heyl Rd. Wooster, Ohio 44691

Prepared by: Shenzhen QC Testing Laboratory Co., Ltd.

1st Floor, Building A, Huawan Industrial Park, Gushu, Xixiang Street,
Baoan, 518126, Shenzhen, China

Tel: 0755-23008269

Fax: 0755-23726780

Report No.: QCT15BR-1202E-3

Issue Date: June 04, 2015

Test Date: May 26~ June 04, 2015

Tested by:

Kare Gao

Kare Gao

Reviewed by:

Carmi Du

Carmi Du

Approved by:

Kendy Wang

Kendy Wang

TABLE OF CONTENTS

- 1. GENERAL INFORMATION..... 3**
 - 1.1 PRODUCT DESCRIPTION FOR EQUIPMENT UNDER TEST (EUT)..... 3
 - 1.2 TEST STANDARDS 4
 - 1.3 TEST METHODOLOGY 4
 - 1.4 TEST FACILITY 4
- 2. SYSTEM TEST CONFIGURATION 5**
 - 2.1 EUT CONFIGURATION 5
 - 2.2 EUT EXERCISE..... 5
 - 2.3 GENERAL TEST PROCEDURES 5
 - 2.4 MEASUREMENT UNCERTAINTY 5
 - 2.5 TEST EQUIPMENT LIST AND DETAILS 6
- 3. SUMMARY OF TEST RESULTS 6**
- 4. TEST OF AC POWER LINE CONDUCTED EMISSION 7**
 - 4.1 APPLICABLE STANDARD..... 7
 - 4.2 TEST SETUP DIAGRAM 7
 - 4.3 TEST RESULT 7
- 5. TEST OF RADIATED EMISSION 10**
 - 5.1 APPLICABLE STANDARD..... 10
 - 5.2 LIMIT OF RADIATED DISTURBANCES 10
 - 5.3 EUT SETUP 11
 - 5.4 TEST EQUIPMENT LIST AND DETAILS 12
 - 5.5 TEST PROCEDURE 12
 - 5.6 TEST RESULT 12
- 6. FREQUENCY TOLERANCE 16**
 - 6.1 APPLICABLE STANDARD..... 16
 - 6.2 EUT SETUP 16
 - 6.3 TEST EQUIPMENT LIST AND DETAILS 16
 - 6.4 TEST PROCEDURE 16
 - 6.5 TEST RESULT 16
- 7. ANTENNA REQUIREMENT 18**
 - 7.1 STANDARD APPLICABLE..... 18
 - 7.2 ANTENNA CONNECTED CONSTRUCTION 18

1. GENERAL INFORMATION

1.1 Product Description for Equipment Under Test (EUT)

Client Information

Applicant:	Prentke Romich Company
Address of Applicant:	1022 Heyl Rd. Wooster, Ohio 44691
Manufacturer:	Prentke Romich Company
Address of Manufacturer:	1022 Heyl Rd. Wooster, Ohio 44691

General Description of E.U.T

Items	Description
EUT Description:	Accent 1000
Model No.:	ACN1000
Supplementary Model:	N/A
Trade Name:	N/A
Transmit Frequency:	13.56MHz
Number of Channels:	1
Duty cycle:	100%
Antenna Type:	Built-in Antenna
Power Supply:	Input: 18VDC 3.4A from AC/DC adapter;7.4VDC from battery
Adapter Information:	Model No:MENB1060A1800N02; Manufacturer: SL POWER and AULT Input: 100-240V~ 50-60Hz 1.5A Max ; Output:18.0V 3.4A

Remark: * The test data gathered are from the production sample provided by the manufacturer.

1.2 Test Standards

The tests were performed in order to determine compliance with FCC Part 15, Subpart C, and section 15.207, 15.209 and 15.225 rules. Test was carried out according to the above mentioned FCC rules.

1.3 Test Methodology

All measurements contained in this report were conducted with CISPR 16-1-1: 2006, radio disturbance and immunity measuring apparatus, and CISPR 16-2-3: 2010, Method of measurement of disturbances and immunity. All measurement required was performed at Shenzhen CTL Testing Technology Co., Ltd. at Floor 1-A, Baisha Technology Park, No.3011, Shahexi Road, Nanshan District, Shenzhen, China 518055

1.4 Test Facility

The test facility is recognized, certified, or accredited by the following organizations:

CNAS – Registration No.: L5540

Shenzhen CTL Testing Technology Co., Ltd. To ISO/IEC 17025:25 General Requirements for the Competence of Testing and Calibration Laboratories (CNAS-CL01 Accreditation Criteria for the Competence of Testing and Calibration Laboratories) for the competence in the field of testing. The acceptance letter from the CNAS is maintained in our files: Registration: L5540, March, 2012.

FCC – Registration No.: 970318

Shenzhen CTL Testing Technology Co., Ltd. EMC Laboratory has been Registered and fully described in a report filed with the (FCC) Federal Communications Commission. The acceptance letter from the FCC is maintained in our files. Registration: 970318, December 19, 2013.

2. SYSTEM TEST CONFIGURATION

2.1 EUT Configuration

The EUT configuration for testing is installed on RF field strength measurement to meet the Commissions requirement and operating in a manner that intends to maximize its emission characteristics in a continuous normal application.

2.2 EUT Exercise

The calibrated antennas used to sample the radiated field strength are mounted on a non-conductive, motorized antenna mast 3 or 10 meters from the leading edge of the turntable.

2.3 General Test Procedures

Conducted Emissions: The EUT is placed on the turntable, which is 0.8 m above ground plane. According to the requirements in Section 7.1 of ANSI C63.4-2003 Conducted emissions from the EUT measured in the frequency range between 0.15 MHz and 30MHz using CISPR Quasi-Peak detector mode.

Radiated Emissions: The EUT is a placed on as turntable, which is 0.8 m above ground plane. The turntable shall rotate 360 degrees to determine the position of maximum emission level. EUT is set 3m away from the receiving antenna, which varied from 1m to 4m to find out the highest emission. And also, each emission was to be maximized by changing the polarization of receiving antenna both horizontal and vertical. In order to find out the maximum emissions, exploratory radiated emission measurements were made according to the requirements in Section 13.1.4.1 of ANSI C63.4-2003.

2.4 Measurement Uncertainty

Where relevant, the following measurement uncertainty levels have been estimated for tests performed on the apparatus:

Parameter	Uncertainty
Power Line Conducted Emission	+/- 2.3 dB
Radiated Emission	+/- 3.4 dB

Uncertainty figures are valid to a confidence level of 95%.

2.5 Test Equipment List and Details

Test equipments list of Shenzhen CTL Testing Technology Co., Ltd.

Item	Test Equipment	Manufacturer	Model No.	Serial No.	Last Cal.
1	ULTRA-BROADBAND ANTENNA	Sunol Sciences Corp.	JB1 Antenna	A061713	2015.05.22
2	EMI TEST RECEIVER	ROHDE & SCHWARZ	ESCI	1166.5950.03	2015.03.19
3	Coaxial	/	/	/	2015.05.22
4	Controller	EM Electronics	Controller EM 1000	N/A	2015.05.22
5	Horn antenna	Sunol sciences corp	DRH-118	A062013	2014.07.22
6	Horn antenna	SCHWARZBECK	BBHA9710	1562	2014.07.22
7	Loop antenna	ZHINAN	ZN30900A	3548	2014.07.22
8	Amplifier	HP	8447D	1937A02492	2015.4.25
9	Broadband preamplifier	SCHWARZBECK	BBV9718	9718-182	2015.4.25
10	Spectrum Analyzer	R&S	FSP	100397	2015.05.22
11	Power Meter	Anritsu	ML2480B	100798	2014.10.25
12	Power Sensor	Anritsu	MA2411B	100258	2014.10.25

3. SUMMARY OF TEST RESULTS

FCC Rules	Description of Test	Result
FCC §15.207	AC Power Line Conducted Emission	Pass
FCC §15.225(a)(b)(c)(d)	Radiated Emission (9kHz ~ 30MHz)	Pass
FCC §15.225(d), 15.209	Radiated Emission (30MHz ~ 1GHz)	Pass
FCC §15.225(e)	Frequency stability	Pass

4. TEST OF AC POWER LINE CONDUCTED EMISSION

4.1 Applicable Standard

Refer to FCC §15.207.

For a Low-power Radio-frequency Device is designed to be connected to the AC power line, the radio frequency voltage that is conducted back onto the AC power line on any frequency or frequencies within the band 150 kHz to 30 MHz shall not exceed below limits table.

Frequency Range (MHz)	Limits (dBuV)	
	Quasi-Peak	Average
0.150~0.500	66~56	56~46
0.500~5.000	56	46
5.000~30.00	60	50

4.2 Test Setup Diagram

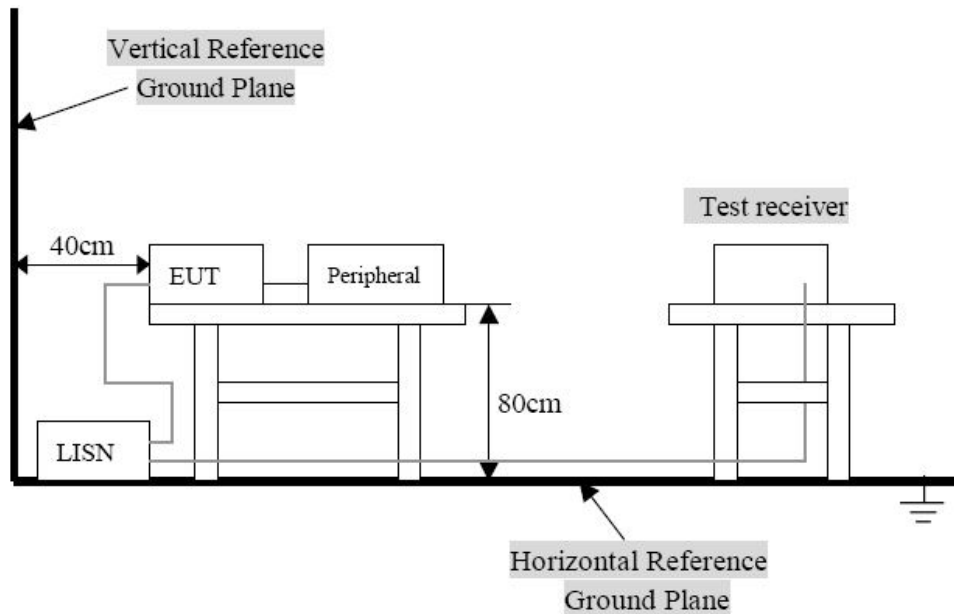

Remark: The EUT was connected to a 120VAC/ 60Hz power source.

4.3 Test Result

Temperature (°C) : 23~25	EUT: Accent 1000
Humidity (%RH) : 45~58	M/N: ACN1000
Barometric Pressure (mbar) : 950~1000	Operation Condition: Normal Operation

Conducted Emission Test Data

EUT: Accent 1000
 Operating Condition: Normal Operation
 Test Site: Shielded Room
 Operator: Andy
 Test Specification: AC/DC adapter (AC 120V/60Hz)
 Comment: Live Line

SCAN TABLE: "Voltage (9K-30M)FIN"
 Short Description: 150K-30M Voltage

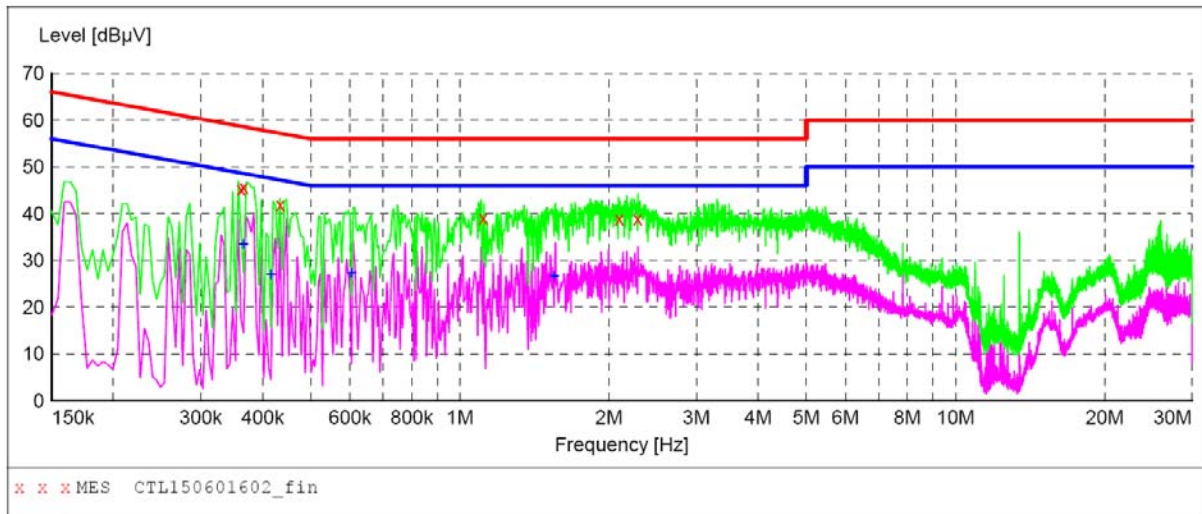

MEASUREMENT RESULT: "CTL150601602_fin"

6/1/2015 9:39AM

Frequency MHz	Level dBµV	Transd dB	Limit dBµV	Margin dB	Detector	Line	PE
0.361500	45.30	10.2	59	13.4	QP	L1	GND
0.366000	45.50	10.2	59	13.1	QP	L1	GND
0.433500	41.90	10.2	57	15.3	QP	L1	GND
1.113000	39.00	10.3	56	17.0	QP	L1	GND
2.094000	38.80	10.4	56	17.2	QP	L1	GND
2.283000	38.90	10.4	56	17.1	QP	L1	GND

MEASUREMENT RESULT: "CTL150601602_fin2"

6/1/2015 9:39AM

Frequency MHz	Level dBµV	Transd dB	Limit dBµV	Margin dB	Detector	Line	PE
0.366000	33.60	10.2	49	15.0	AV	L1	GND
0.415500	27.10	10.2	48	20.4	AV	L1	GND
0.604500	27.40	10.2	46	18.6	AV	L1	GND
1.549500	26.60	10.3	46	19.4	AV	L1	GND

Conducted Emission Test Data

EUT: Accent 1000
 Operating Condition: Normal Operation
 Test Site: Shielded Room
 Operator: Andy
 Test Specification: AC/DC adapter (AC 120V/60Hz)
 Comment: Neutral Line

SCAN TABLE: "Voltage (9K-30M)FIN"
 Short Description: 150K-30M Voltage

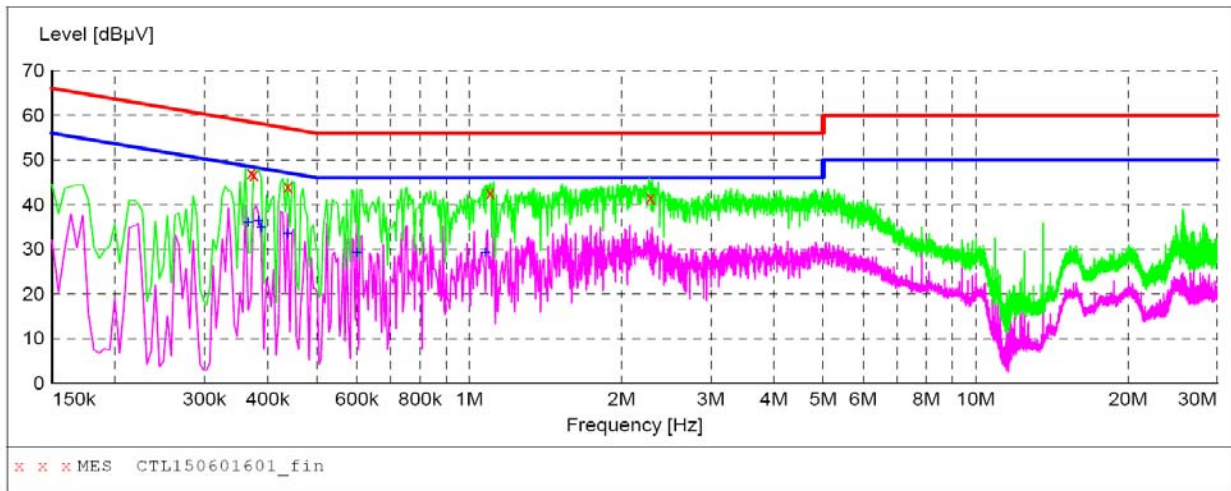

MEASUREMENT RESULT: "CTL150601601_fin"

6/1/2015 9:36AM

Frequency MHz	Level dBµV	Transd dB	Limit dBµV	Margin dB	Detector	Line	PE
0.370500	47.00	10.2	59	11.5	QP	N	GND
0.375000	46.60	10.2	58	11.8	QP	N	GND
0.438000	44.00	10.2	57	13.1	QP	N	GND
1.099500	42.60	10.3	56	13.4	QP	N	GND
2.278500	41.50	10.4	56	14.5	QP	N	GND

MEASUREMENT RESULT: "CTL150601601_fin2"

6/1/2015 9:36AM

Frequency MHz	Level dBµV	Transd dB	Limit dBµV	Margin dB	Detector	Line	PE
0.366000	36.10	10.2	49	12.5	AV	N	GND
0.384000	36.40	10.2	48	11.8	AV	N	GND
0.388500	34.90	10.2	48	13.2	AV	N	GND
0.438000	33.50	10.2	47	13.6	AV	N	GND
0.600000	29.40	10.2	46	16.6	AV	N	GND
1.077000	29.40	10.3	46	16.6	AV	N	GND

5. Test of Radiated Emission

5.1 Applicable Standard

Section 15.225 (a) The field strength of any emissions within the band 13.553-13.567 MHz shall not exceed 15,848 microvolts/meter at 30 meters.

Section 15.225 (b) Within the bands 13.410-13.553 MHz and 13.567-13.710 MHz, the field strength of any emissions shall not exceed 334 microvolts/meter at 30 meters.

Section 15.225 (c) Within the bands 13.110-13.410 MHz and 13.710-14.010 MHz the field strength of any emissions shall not exceed 106 microvolts/meter at 30 meters.

Section 15.225 (d) The field strength of any emissions appearing outside of the 13.110-14.010 MHz band shall not exceed the general radiated emission limits in § 15.209.

5.2 Limit of Radiated Disturbances

Except as provided elsewhere in this Subpart, the emissions from an intentional radiator shall not exceed the field strength levels specified in the following table:

Frequency (MHz)	Field strength @30m (uV/m)	Field strength @30m (dBuV/m)	Field strength @3m (dBuV/m)
Below 13.110	30	29.5	69.5
13.110 ~13.410	106	40.5	80.5
13.410~13.553	334	50.5	90.5
13.553~13.567	15,848	84	124
13.567~13.710	334	50.5	90.5
13.710~14.010	106	40.5	80.5
Above 14.010	30	29.5	69.5

Note:

(1) The tighter limit shall apply at the edge between two frequency bands.

(2) $\text{dBuV/m} = 20 \cdot \log(\text{uV/m})$

(3) Distance factor = 40dB / decade(15.31(f))

FCC Part15, Subpart C Section 15.209 limit of radiated emission for frequency below1000MHz. The emissions from an intentional radiator shall not exceed the field strength levels specified in the following table:

Frequency (MHz)	Distance (Meters)	Field Strengths Limits (dB μ V/m)
0.009 -0.490	300	2400/F(KHz)
0.490 -1.705	30	24000/F(KHz)
1.705 -30	30	30
30 -88	3	40.0
88 -216	3	43.5
216 -960	3	46.0
Above 960	3	54.0

Note:

(1) The tighter limit shall apply at the edge between two frequency bands.

(2) Distance refers to the distance in meters between the test instrument antenna and the closest point of any part of the E.U.T.

5.3 EUT Setup

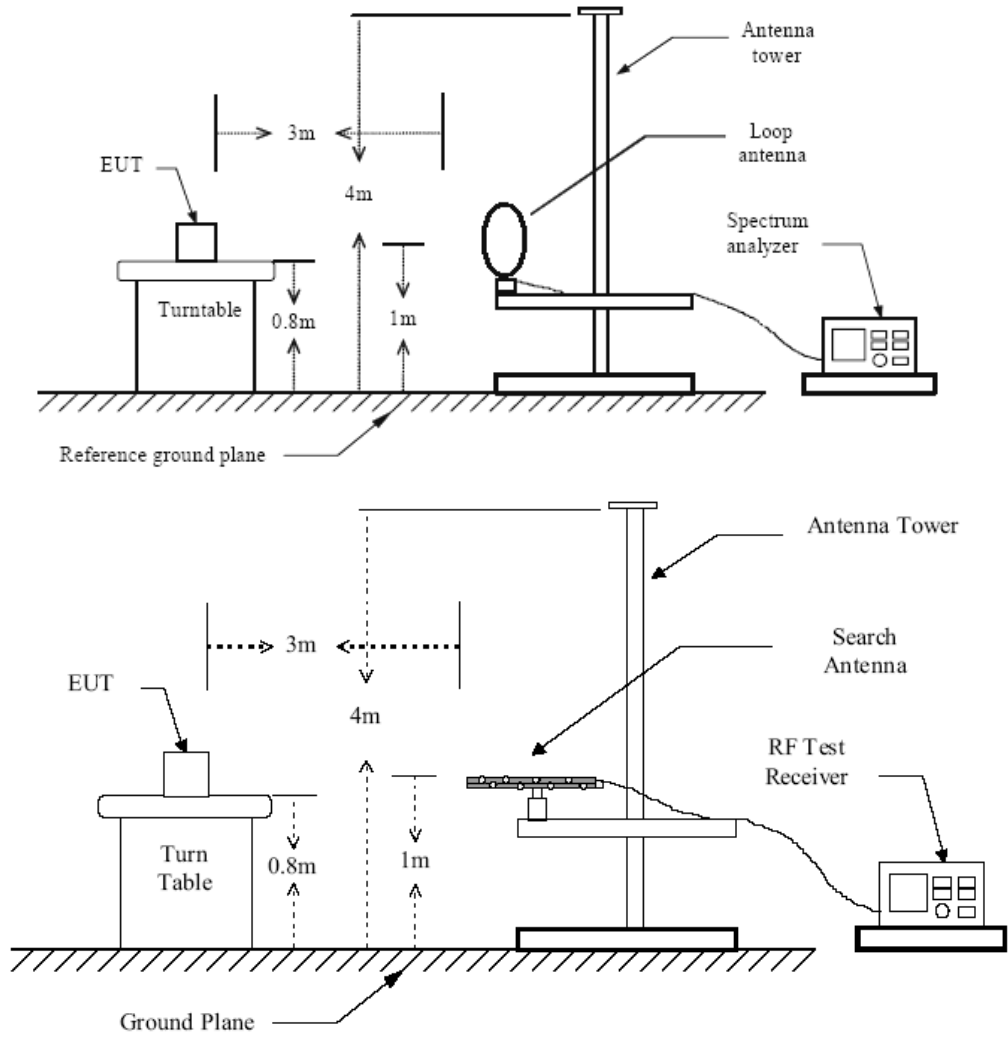

Figure 1 : Frequencies measured below 1 GHz configuration

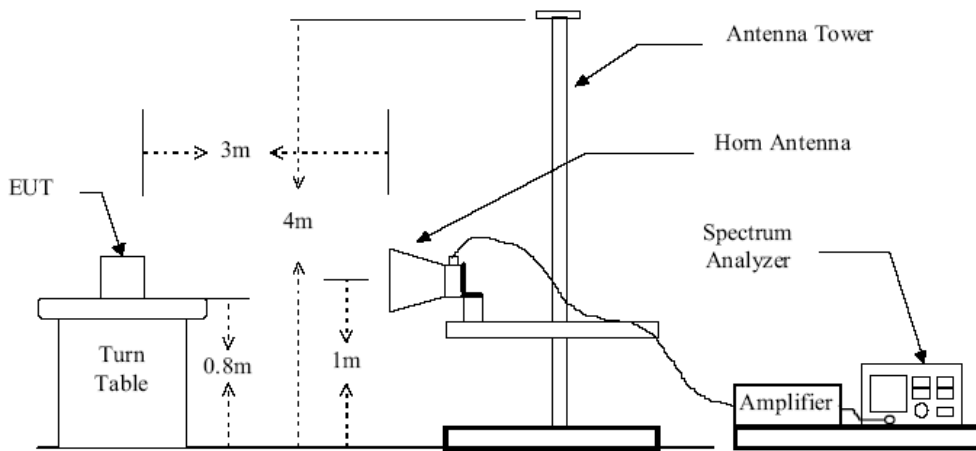

Figure 2 : Frequencies measured above 1 GHz configuration

5.4 Test Equipment List and Details

See section 2.5.

5.5 Test Procedure

1. Configure the EUT according to ANSI C63.4-2003
2. The EUT was placed on the top of the turntable 0.8 meter above ground.
3. Receiving antenna mounted on the top of a height-variable antenna tower was placed 3 meters far away from the turntable. When the frequency spectrum measured started from 9 kHz to 30 MHz, a loop antenna is used. When the frequency spectrum measured started from 30 MHz to 1000 MHz or above 1000 MHz, a broadband receiving antenna or the horn antenna are used.
4. Power on the EUT and all the supporting units.
5. The turntable was rotated by 360 degrees to determine the position of the highest radiation.
6. The height of the receiving antenna was varied between one meter and four meters above ground to find the maximum emission field strength of both horizontal and vertical polarization.
7. For each suspected emission, the antenna tower was scanned (from 1 M to 4 M) and then the turntable was rotated (from 0 degree to 360 degrees) to find the maximum reading.
8. Set the test-receiver system to Peak, CISPR quasi-peak or Average detect function with specified bandwidth according to different frequency spectrum measured under Maximum Hold Mode.

5.6 Test Result

Temperature (°C) : 22~23	EUT: Accent 1000
Humidity (%RH) : 50~54	M/N: ACN1000
Barometric Pressure (mbar) : 950~1000	Operation Condition: Tx Mode

NOTE:

In this testing, the EUT was respectively tested in three different orientations. That is:

- (1) EUT was lie vertically, and then its Antenna oriented upward
- (2) EUT was lie vertically, and then its Antenna oriented downward
- (3) EUT was lie flatwise, and then its Antenna oriented to the receiving antenna

The worst test data see following pages When the EUT was lie vertically, and then its Antenna oriented upward, the worst test data was got as following table.

WORST-CASE RADIATED EMISSION BELOW 30 MHz

Frequency	Meter Reading	Polar	Antenna Factor	Cable Loss	Emission Levels	Limits at 3m	Margin	Detector Mode
(MHz)	(dB μ V)	H/V	(dB/m)	(dB)	(dB μ V/m)	(dB μ V/m)	(dB)	QP /AV
13.56	87.52	V	10.75	1.34	96.93	124	-27.07	QP
13.553	18.33	V	10.34	1.34	27.33	70	-42.67	QP
13.557	19.47	V	10.34	1.35	31.16	70	-38.84	QP
21.45	20.05	V	8.66	1.08	27.63	49.5	-21.87	QP
25.43	21.83	V	7.49	1.66	27.66	49.5	-21.84	QP

Remark:

1. Data of measurement within this frequency range shown “ - ” in the table above means the reading of emissions are attenuated more than 20dB below the permissible limits or the field strength is too small to be measured.
2. The test limit distance is 3m limit.
3. PK means Peak Value, QP means Quasi Peak Value, AV means Average Value.

Radiated Emission Test Data Below 1G:

EUT: Accent 1000
M/N: ACN1000
Operating Condition: Tx Mode
Test Site: 3m CHAMBER
Operator: Chen
Test Specification: AC 120V/60Hz
Comment: Polarization: Horizontal

SWEEP TABLE: "test (30M-1G)"

Short Description:		Field Strength			
Start	Stop	Detector	Meas. Time	IF Bandw.	Transducer
Frequency	Frequency				
30.0 MHz	1.0 GHz	MaxPeak	500.0 ms	100 kHz	VULB9168

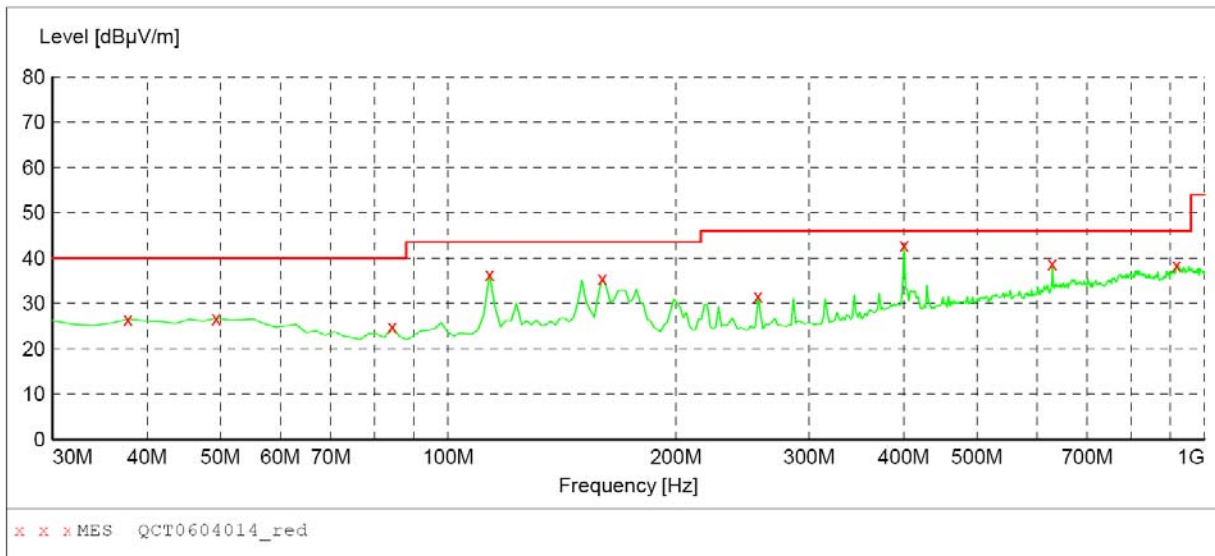

MEASUREMENT RESULT: "QCT0604014_red"

6/4/2015 5:02PM

Frequency MHz	Level dBµV/m	Transd dB	Limit dBµV/m	Margin dB	Det.	Height cm	Azimuth deg	Polarization
37.760000	26.60	14.3	40.0	13.4	QP	200.0	0.00	HORIZONTAL
49.400000	26.80	14.1	40.0	13.2	QP	100.0	0.00	HORIZONTAL
84.320000	24.90	10.3	40.0	15.1	QP	200.0	0.00	HORIZONTAL
113.420000	36.50	12.5	43.5	7.0	QP	200.0	0.00	HORIZONTAL
159.980000	35.50	15.3	43.5	8.0	QP	200.0	0.00	HORIZONTAL
256.980000	31.60	13.3	46.0	14.4	QP	100.0	0.00	HORIZONTAL
400.540000	42.80	16.8	46.0	3.2	QP	100.0	0.00	HORIZONTAL
629.460000	38.80	21.4	46.0	7.2	QP	100.0	0.00	HORIZONTAL
918.520000	38.40	25.0	46.0	7.6	QP	200.0	0.00	HORIZONTAL

Radiated Emission Test Data Below 1G:

EUT: Accent 1000
M/N: ACN1000
Operating Condition: Tx Mode
Test Site: 3m CHAMBER
Operator: Chen
Test Specification: AC 120V/60Hz
Comment: Polarization: Vertical

SWEEP TABLE: "test (30M-1G)"

Short Description:		Field Strength			
Start	Stop	Detector	Meas. Time	IF Bandw.	Transducer
30.0 MHz	1.0 GHz	MaxPeak	500.0 ms	100 kHz	VULB9168

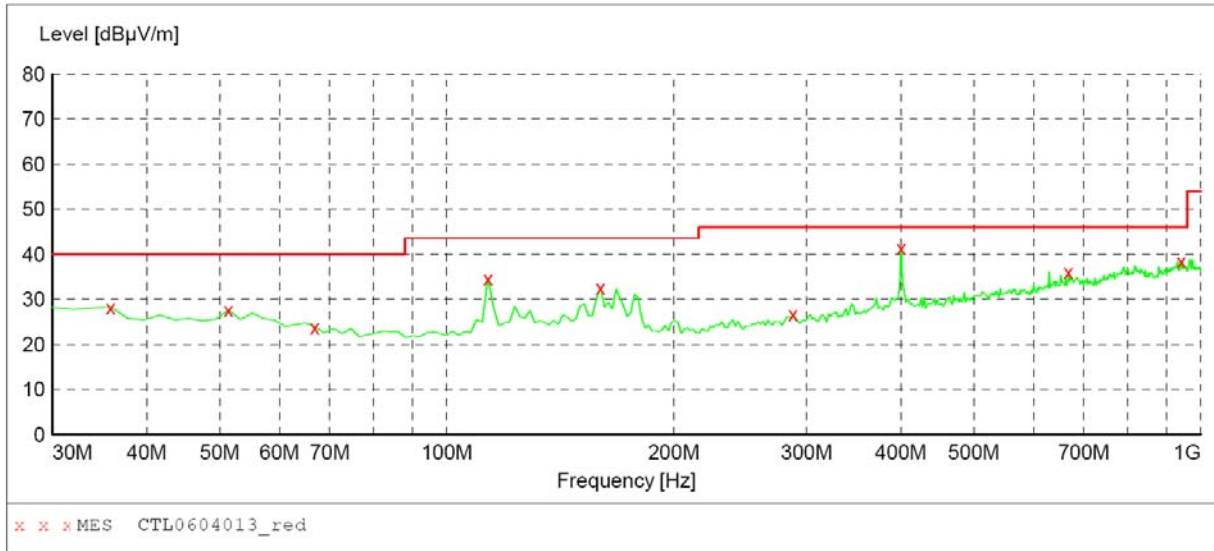

MEASUREMENT RESULT: "CTL0604013_red"

6/4/2015 4:59PM

Frequency MHz	Level dBµV/m	Transd dB	Limit dBµV/m	Margin dB	Det.	Height cm	Azimuth deg	Polarization
35.820000	28.30	14.0	40.0	11.7	QP	100.0	0.00	VERTICAL
51.340000	27.60	14.0	40.0	12.4	QP	100.0	0.00	VERTICAL
66.860000	23.80	12.1	40.0	16.2	QP	100.0	0.00	VERTICAL
113.420000	34.70	12.5	43.5	8.8	QP	100.0	0.00	VERTICAL
159.980000	32.60	15.3	43.5	10.9	QP	100.0	0.00	VERTICAL
288.020000	26.70	14.2	46.0	19.3	QP	100.0	0.00	VERTICAL
400.540000	41.40	16.8	46.0	4.6	QP	100.0	0.00	VERTICAL
668.260000	36.10	22.0	46.0	9.9	QP	100.0	0.00	VERTICAL
941.800000	38.50	25.2	46.0	7.5	QP	100.0	0.00	VERTICAL

6. Frequency Tolerance

6.1 Applicable Standard

Section 15.225(e): The frequency tolerance of the carrier signal shall be maintained within +/- 0.01% of the operating frequency over a temperature variation of -20 degrees to +50 degrees C at normal supply voltage, and for a variation in the primary supply voltage from 85% to 115% of the rated supply voltage at a temperature of 20 degrees C. For battery operated equipment, the equipment tests shall be performed using a new battery.

6.2 EUT Setup

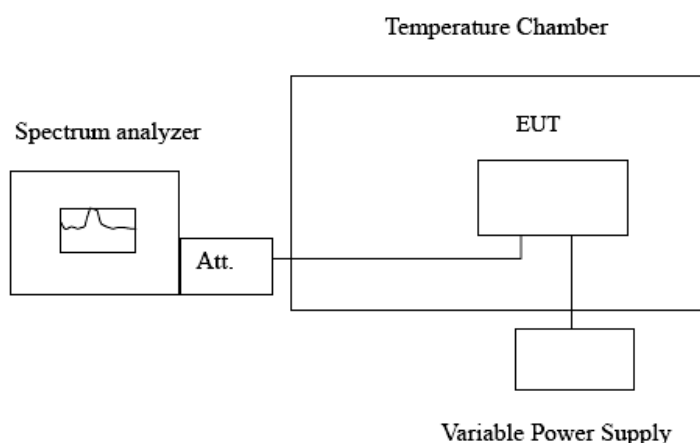

6.3 Test Equipment List and Details

See section 2.5.

6.4 Test Procedure

The frequency stability of the transmitter is measured by:

- (a) Temperature: The temperature is varied from -20 to $^{\circ}\text{C}$ +50 $^{\circ}\text{C}$ using an environmental chamber.
- (b) Primary Supply Voltage: The primary supply voltage is varied from 85% to 115% of the voltage normally input to the device or at the power supply terminals if cables are not normally supplied.

The frequency tolerance of the carrier shall be maintained within $\pm 0.01\%$ of the operating frequency.

6.5 Test Result

Temperature ($^{\circ}\text{C}$) : 22~23	EUT: Accent 1000
Humidity (%RH) : 50~54	M/N: ACN1000
Barometric Pressure (mbar) : 950~1000	Operation Condition: Tx Mode

Voltage (%)	Power (VAC)	Temperature (°C)	Frequency (MHz)	Deviation (%)
100	120	+20°C(Ref)	13.559546	-0.000033
100	120	-20	13.559675	-0.000024
100	120	-10	13.559689	-0.000023
100	120	0	13.559636	-0.000027
100	120	10	13.559648	-0.000026
100	120	25	13.559563	-0.000032
100	120	30	13.559536	-0.000034
100	120	40	13.559574	-0.000031
100	120	50	13.559566	-0.000032
85	102	20	13.559548	-0.000033
115	138	20	13.559598	-0.000030

7. ANTENNA REQUIREMENT

7.1 Standard Applicable

Section 15.203:

An intentional radiator shall be designed to ensure that no antenna other than that furnished by the responsible party shall be used with the device. The use of a permanently attached antenna or of an antenna that uses a unique coupling to the intentional radiator shall be considered sufficient to comply with the provisions of this Section. The manufacturer may design the unit so that a broken antenna can be replaced by the user, but the use of a standard antenna jack or electrical connector is prohibited.

7.2 Antenna Connected Construction

The antenna connector is designed with permanent attachment and no consideration of replacement. The antenna used in this product is complied with Standard. The maximum Gain of the antenna lower than 6.0dBi and have the definite antenna Specification.