



RADIO TEST REPORT

Report No: STS1912045W01

Issued for

Prentke Romich Company

1022 Heyl Rd. Wooster, Ohio 44691, USA

| | |
|-----------------------|--------------------------------|
| Product Name: | Accent 1400 |
| Brand Name: | Accent |
| Model Name: | ACN1400-30 |
| Series Model: | N/A |
| FCC ID: | 2AD9PA-ACN140030PRC |
| IC: | 23408-ACN140030 |
| Test Standard: | FCC Part 15.247 |
| | RSS-247 Issue 2, February 2017 |

Any reproduction of this document must be done in full. No single part of this document may be reproduced without permission from STS, All Test Data Presented in this report is only applicable to presented Test sample.

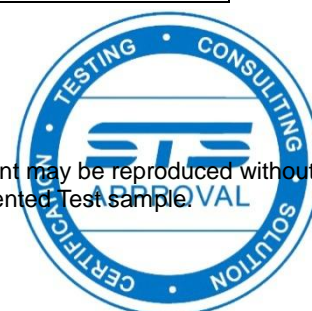



TEST RESULT CERTIFICATION

Applicant's Name: Prentke Romich Company
Address.....: 1022 Heyl Rd. Wooster, Ohio 44691, USA
Manufacture's Name: Prentke Romich Company
Address.....: 1022 Heyl Rd. Wooster, Ohio 44691, USA

Product Description

Product Name: Accent 1400
Brand Name: Accent
Model Name.....: ACN1400-30
Series Model: N/A
Test Standards: FCC Part15.247
RSS-247 Issue 2, February 2017
Test Procedure.....: ANSI C63.10-2013

This device described above has been tested by STS, the test results show that the equipment under test (EUT) is in compliance with the FCC&IC requirements. And it is applicable only to the tested sample identified in the report. This report shall not be reproduced except in full, without the written approval of STS, this document may be altered or revised by STS, personal only, and shall be noted in the revision of the document.

Date of Test.....:
Date of receipt of test item: 12 Dec. 2019
Date (s) of performance of tests : 12 Dec. 2019 ~ 31 Dec. 2019
Date of Issue: 02 Jan. 2019
Test Result: Pass

Testing Engineer : [Signature]
(Chris Chen)

Technical Manager : [Signature]
(Sunday Hu)

Authorized Signatory : [Signature]
(Vita Li)





| Table of Contents | Page |
|---|-----------|
| 1. SUMMARY OF TEST RESULTS | 6 |
| 1.1 TEST FACTORY | 7 |
| 1.2 MEASUREMENT UNCERTAINTY | 7 |
| 2. GENERAL INFORMATION | 8 |
| 2.1 GENERAL DESCRIPTION OF THE EUT | 8 |
| 2.2 DESCRIPTION OF THE TEST MODES | 10 |
| 2.3 TABLE OF PARAMETERS OF TEST SOFTWARE SETTING | 10 |
| 2.4 BLOCK DIGRAM SHOWING THE CONFIGURATION OF SYSTEM TESTED | 11 |
| 2.5 DESCRIPTION OF NECESSARY ACCESSORIES AND SUPPORT UNITS | 12 |
| 2.6 EQUIPMENTS LIST | 13 |
| 3. EMC EMISSION TEST | 14 |
| 3.1 CONDUCTED EMISSION MEASUREMENT | 14 |
| 3.2 RADIATED EMISSION MEASUREMENT | 20 |
| 4. CONDUCTED SPURIOUS & BAND EDGE EMISSION | 37 |
| 4.1 LIMIT | 37 |
| 4.2 TEST PROCEDURE | 37 |
| 4.3 TEST SETUP | 37 |
| 4.4 EUT OPERATION CONDITIONS | 37 |
| 4.5 TEST RESULTS | 38 |
| 5. NUMBER OF HOPPING CHANNEL | 53 |
| 5.1 LIMIT | 53 |
| 5.2 TEST PROCEDURE | 53 |
| 5.3 TEST SETUP | 53 |
| 5.4 EUT OPERATION CONDITIONS | 53 |
| 5.5 TEST RESULTS | 54 |
| 6. AVERAGE TIME OF OCCUPANCY | 55 |
| 6.1 LIMIT | 55 |
| 6.2 TEST PROCEDURE | 55 |
| 6.3 TEST SETUP | 55 |
| 6.4 EUT OPERATION CONDITIONS | 55 |
| 6.5 TEST RESULTS | 56 |
| 7. HOPPING CHANNEL SEPARATION MEASUREMEN | 62 |
| 7.1 LIMIT | 62 |



| Table of Contents | Page |
|--|-----------|
| 7.2 TEST PROCEDURE | 62 |
| 7.3 TEST SETUP | 62 |
| 7.4 EUT OPERATION CONDITIONS | 62 |
| 7.5 TEST RESULTS | 63 |
| 8. BANDWIDTH TEST | 69 |
| 8.1 LIMIT | 69 |
| 8.2 TEST PROCEDURE | 69 |
| 8.3 TEST SETUP | 69 |
| 8.4 EUT OPERATION CONDITIONS | 69 |
| 8.5 TEST RESULTS | 70 |
| 9. OUTPUT POWER TEST | 76 |
| 9.1 LIMIT | 76 |
| 9.2 TEST PROCEDURE | 76 |
| 9.3 TEST SETUP | 77 |
| 9.4 EUT OPERATION CONDITIONS | 77 |
| 9.5 TEST RESULTS | 78 |
| 10. ANTENNA REQUIREMENT | 80 |
| 10.1 STANDARD REQUIREMENT | 80 |
| 10.2 EUT ANTENNA | 80 |
| 11. FREQUENCY STABILITY | 81 |
| 11.1 LIMITS OF FREQUENCY STABILITY MEASUREMENT | 81 |
| 11.2 TEST PROCEDURE | 81 |
| 11.3 TEST RESULT | 81 |



Revision History

| Rev. | Issue Date | Report NO. | Effect Page | Contents |
|------|--------------|---------------|-------------|---------------|
| 00 | 02 Jan. 2019 | STS1912045W01 | ALL | Initial Issue |
| | | | | |





1. SUMMARY OF TEST RESULTS

Test procedures according to the technical standards:
KDB 558074 D01 15.247 Meas Guidance v05r02.

| FCC Part 15.247, Subpart C RSS-247 Issue 2 | | | |
|---|---|----------|--------|
| Standard Section | Test Item | Judgment | Remark |
| 15.207 RSS-Gen Issue 5, Amendment 1, March 2019 | Conducted Emission & Receiver AC power-line conducted emissions | PASS | -- |
| 15.247(a)(1) RSS-247 Issue 2, February 2017 (5.1) | Hopping Channel Separation | PASS | -- |
| 15.247(a)(1)&(b)(1) RSS-247 Issue 2, February 2017 (5.1) | Output Power | PASS | -- |
| 15.247(c) RSS-247 Issue 2, February 2017 (5.5) | Radiated Spurious Emission & Receiver radiated emissions | PASS | -- |
| 15.247(d) RSS-247 Issue 2, February 2017 (5.5) | Conducted Spurious & Band Edge Emission | PASS | -- |
| 15.247(a)(iii) RSS-247 Issue 2, February 2017 (5.1) | Number of Hopping Frequency | PASS | -- |
| 15.247(a)(iii) RSS-247 Issue 2, February 2017 (5.1) | Dwell Time | PASS | -- |
| 15.247(a)(1) RSS-247 Issue 2, February 2017 (5.1) | Bandwidth | PASS | -- |
| 15.205 RSS-Gen Issue 5, Amendment 1, March 2019 | Restricted Band Edge Emission | PASS | -- |
| Part 15.247(d)/part 15.209(a) RSS-247 Issue 2, February 2017 (5.5) | Band Edge Emission | PASS | -- |
| 15.203 RSS-Gen Issue 5, Amendment 1, March 2019 | Antenna Requirement | PASS | -- |
| RSS-Gen Issue 5, Amendment 1, March 2019 | Frequency Stability | PASS | -- |

NOTE:

- (1) 'N/A' denotes test is not applicable in this Test Report.
- (2) All tests are according to ANSI C63.10-2013.



1.1 TEST FACTORY

SHENZHEN STS TEST SERVICES CO., LTD

Add. : A 1/F, Building B, Zhuoke Science Park, No.190 Chongqing Road, HepingShequ, Fuyong Sub-District, Bao'an District, Shenzhen, Guang Dong, China

FCC test Firm Registration Number: 625569

IC test Firm Registration Number: 12108A

A2LA Certificate No.: 4338.01

1.2 MEASUREMENT UNCERTAINTY

The reported uncertainty of measurement $y \pm U$, where expanded uncertainty U is based on a standard uncertainty multiplied by a coverage factor of $k=2$, providing a level of confidence of approximately **95 %**.

| No. | Item | Uncertainty |
|-----|-----------------------------------|----------------------|
| 1 | RF output power, conducted | $\pm 0.68\text{dB}$ |
| 2 | Unwanted Emissions, conducted | $\pm 2.988\text{dB}$ |
| 3 | All emissions, radiated 30-1GHz | $\pm 6.7\text{dB}$ |
| 4 | All emissions, radiated 1G-6GHz | $\pm 5.5\text{dB}$ |
| 5 | All emissions, radiated >6G | $\pm 5.8\text{dB}$ |
| 6 | Conducted Emission (9KHz-150KHz) | $\pm 4.43\text{dB}$ |
| 7 | Conducted Emission (150KHz-30MHz) | $\pm 5\text{dB}$ |



2. GENERAL INFORMATION

2.1 GENERAL DESCRIPTION OF THE EUT

| | |
|-------------------------|--|
| Product Name | Accent 1400 |
| Trade Name | Accent |
| Model Name | ACN1400-30 |
| Series Model | N/A |
| Model Difference | N/A |
| Channel List | Please refer to the Note 2. |
| Bluetooth | Frequency:2402 – 2480 MHz Modulation: GFSK(1Mbps), $\pi/4$ -DQPSK(2Mbps), 8DPSK(3Mbps) |
| Bluetooth Version | 4.2 |
| Bluetooth Configuration | BR+EDR |
| Adapter | Input: AC 100~240V, 1500mA, 50/60Hz Output: DC 18V, 3330mA |
| Battery | Rated Voltage: 7.4V Charge Limit: 8.4V Capacity: 9200mAh |
| Hardware version number | A1400-30_MB_VERC |
| Software version number | Windows 10 Pro 64-bit |
| Connecting I/O Port(s) | Please refer to the User's Manual |

Note:

1. For a more detailed features description, please refer to the manufacturer's specifications or the User Manual.



2.

| Channel List | | | | | |
|--------------|-----------------|---------|-----------------|---------|-----------------|
| Channel | Frequency (MHz) | Channel | Frequency (MHz) | Channel | Frequency (MHz) |
| 00 | 2402 | 27 | 2429 | 54 | 2456 |
| 01 | 2403 | 28 | 2430 | 55 | 2457 |
| 02 | 2404 | 29 | 2431 | 56 | 2458 |
| 03 | 2405 | 30 | 2432 | 57 | 2459 |
| 04 | 2406 | 31 | 2433 | 58 | 2460 |
| 05 | 2407 | 32 | 2434 | 59 | 2461 |
| 06 | 2408 | 33 | 2435 | 60 | 2462 |
| 07 | 2409 | 34 | 2436 | 61 | 2463 |
| 08 | 2410 | 35 | 2437 | 62 | 2464 |
| 09 | 2411 | 36 | 2438 | 63 | 2465 |
| 10 | 2412 | 37 | 2439 | 64 | 2466 |
| 11 | 2413 | 38 | 2440 | 65 | 2467 |
| 12 | 2414 | 39 | 2441 | 66 | 2468 |
| 13 | 2415 | 40 | 2442 | 67 | 2469 |
| 14 | 2416 | 41 | 2443 | 68 | 2470 |
| 15 | 2417 | 42 | 2444 | 69 | 2471 |
| 16 | 2418 | 43 | 2445 | 70 | 2472 |
| 17 | 2419 | 44 | 2446 | 71 | 2473 |
| 18 | 2420 | 45 | 2447 | 72 | 2474 |
| 19 | 2421 | 46 | 2448 | 73 | 2475 |
| 20 | 2422 | 47 | 2449 | 74 | 2476 |
| 21 | 2423 | 48 | 2450 | 75 | 2477 |
| 22 | 2424 | 49 | 2451 | 76 | 2478 |
| 23 | 2425 | 50 | 2452 | 77 | 2479 |
| 24 | 2426 | 51 | 2453 | 78 | 2480 |
| 25 | 2427 | 52 | 2454 | | |
| 26 | 2428 | 53 | 2455 | | |

3. Table for Filed Antenna

| Ant. | Brand | Model Name | Antenna Type | Connector | Gain (dBi) | NOTE |
|------|--------|------------|--------------|-----------|------------|------------|
| 1 | Accent | ACN1400-30 | PIFA | N/A | 0dBi | BT Antenna |



2.2 DESCRIPTION OF THE TEST MODES

To investigate the maximum EMI emission characteristics generates from EUT, the test system was pre-scanning tested base on the consideration of following EUT operation mode or test configuration mode which possible have effect on EMI emission level. Each of these EUT operation mode(s) or test configuration mode(s) mentioned above was evaluated respectively.

| Worst Mode | Description | Data Rate/Modulation |
|------------|-------------|------------------------|
| Mode 1 | TX CH00 | 1Mbps/GFSK |
| Mode 2 | TX CH39 | 1Mbps/GFSK |
| Mode 3 | TX CH78 | 1Mbps/GFSK |
| Mode 4 | TX CH00 | 2 Mbps/ π /4-DQPSK |
| Mode 5 | TX CH39 | 2 Mbps/ π /4-DQPSK |
| Mode 6 | TX CH78 | 2 Mbps/ π /4-DQPSK |
| Mode7 | TX CH00 | 3 Mbps/8DPSK |
| Mode 8 | TX CH39 | 3 Mbps/8DPSK |
| Mode 9 | TX CH78 | 3 Mbps/8DPSK |

Note:

- (1) The measurements are performed at all Bit Rate of Transmitter, the worst data was reported.
- (2) We have be tested for all avaiable U.S. voltage and frequencies(For 120V,50/60Hz and 240V, 50/60Hz) for which the device is capable of operation, and the worst case of 120V/60Hz is shown in the report.

For AC Conducted Emission

| Test Case | |
|-----------------------|-------------------------|
| AC Conducted Emission | Mode 10 : Keeping BT TX |

2.3 TABLE OF PARAMETERS OF TEST SOFTWARE SETTING

During testing channel & power controlling software provided by the customer was used to control the operating channel as well as the output power level. The RF output power selection is for the setting of RF output power expected by the customer and is going to be fixed on the firmware of the final end product power parameters of FHSS.

| Test software Version | Test program: Bluetooth | | |
|--|---|---|--|
| (Power control software) Parameters(1/2/3Mbps) | Power class: DH1 rate:4:27 2DH1 rate:20:54 3DH1 rate:24:83 | Power class: DH3 rate:11:183 2DH3 rate:26:367 3DH3 rate:27:552 | Power class: DH5 rate:15:339 2DH5 rate:30:679 3DH5 rate:31:1021 |



2.4 BLOCK DIGRAM SHOWING THE CONFIGURATION OF SYSTEM TESTED

Radiated Spurious Emission Test

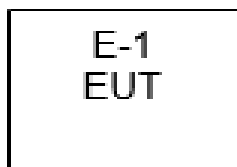

Conducted Emission Test

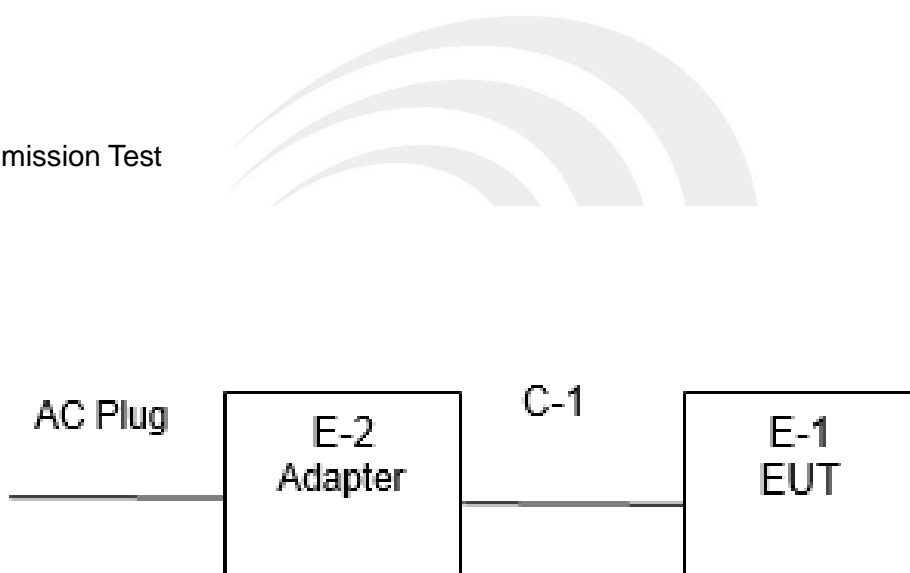



2.5 DESCRIPTION OF NECESSARY ACCESSORIES AND SUPPORT UNITS

The EUT has been tested as an independent unit together with other necessary accessories or support units. The following support units or accessories were used to form a representative test configuration during the tests.

Necessary accessories

| Item | Equipment | Mfr/Brand | Model/Type No. | Serial No. | Note |
|------|-----------|-----------|-------------------|------------|------|
| E-2 | Adapter | MEGMEET | MANGO60S-18BB-PRC | N/A | N/A |
| C-1 | DC Cable | N/A | 100cm | N/A | N/A |
| | | | | | |
| | | | | | |

Support units

| Item | Equipment | Mfr/Brand | Model/Type No. | Serial No. | Note |
|------|-----------|-----------|----------------|------------|------|
| N/A | N/A | N/A | N/A | N/A | N/A |
| | | | | | |
| | | | | | |
| | | | | | |

Note:

- (1) The support equipment was authorized by Declaration of Confirmation.
- (2) For detachable type I/O cable should be specified the length in cm in 『Length』 column.



2.6 EQUIPMENTS LIST

Radiation Test equipment

| Kind of Equipment | Manufacturer | Type No. | Serial No. | Last calibration | Calibrated until |
|----------------------------------|--------------|----------------------------|------------------|------------------|------------------|
| Test Receiver | R&S | ESCI | 101427 | 2019.07.29 | 2020.07.28 |
| Signal Analyzer | Agilent | N9020A | MY51110105 | 2019.03.02 | 2020.03.01 |
| Active loop Antenna | ZHINAN | ZN30900C | 16035 | 2018.03.11 | 2021.03.10 |
| Bilog Antenna | TESEQ | CBL6111D | 34678 | 2017.11.02 | 2020.11.01 |
| Horn Antenna | SCHWARZBECK | BBHA 9120D(1201) | 9120D-1343 | 2018.10.19 | 2021.10.18 |
| SHF-EHF Horn Antenna (18G-40GHz) | A-INFO | LB-180400-KF | J211020657 | 2018.03.11 | 2021.03.10 |
| Pre-Amplifier(0.1M-3G Hz) | EM | EM330 | 060665 | 2019.10.09 | 2020.10.08 |
| Pre-Amplifier (1G-18GHz) | SKET | LNPA-01018G-45 | SK201808090 1 | 2019.10.09 | 2020.10.08 |
| Temperature & Humidity | HH660 | Mieo | N/A | 2019.10.09 | 2020.10.08 |
| turn table | EM | SC100_1 | 60531 | N/A | N/A |
| Antenna mast | EM | SC100 | N/A | N/A | N/A |
| Test SW | FARAD | EZ-EMC(Ver.STSLAB-03A1 RE) | | | |

Conduction Test equipment

| Kind of Equipment | Manufacturer | Type No. | Serial No. | Last calibration | Calibrated until |
|------------------------|--------------|----------------------------|------------|------------------|------------------|
| Test Receiver | R&S | ESCI | 101427 | 2019.07.29 | 2020.07.28 |
| LISN | R&S | ENV216 | 101242 | 2019.10.09 | 2020.10.08 |
| LISN | EMCO | 3810/2NM | 23625 | 2019.10.09 | 2020.10.08 |
| Temperature & Humidity | HH660 | Mieo | N/A | 2019.10.12 | 2020.10.11 |
| Test SW | FARAD | EZ-EMC(Ver.STSLAB-03A1 CE) | | | |

RF Connected Test

| Kind of Equipment | Manufacturer | Type No. | Serial No. | Last calibration | Calibrated until |
|------------------------|--------------|-----------------|---------------|------------------|------------------|
| USB RF power sensor | DARE | RPR3006W | 15I00041SNO03 | 2019.10.09 | 2020.10.08 |
| Signal Analyzer | Agilent | N9020A | MY49100060 | 2019.10.09 | 2020.10.08 |
| Temperature & Humidity | HH660 | Mieo | N/A | 2019.10.12 | 2020.10.11 |
| Test SW | FARAD | LZ-RF /LzRf-3A3 | | | |



3. EMC EMISSION TEST

3.1 CONDUCTED EMISSION MEASUREMENT

3.1.1 POWER LINE CONDUCTED EMISSION LIMITS

Operating frequency band. In case the emission fall within the restricted band specified on Part 207(a) and RSS-Gen limit in the table below has to be followed.

| FREQUENCY (MHz) | Conducted Emissionlimit (dBuV) | |
|-----------------|--------------------------------|-----------|
| | Quasi-peak | Average |
| 0.15 -0.5 | 66 - 56 * | 56 - 46 * |
| 0.50 -5.0 | 56.00 | 46.00 |
| 5.0 -30.0 | 60.00 | 50.00 |

Note:

- (1) The tighter limit applies at the band edges.
- (2) The limit of “ * ” marked band means the limitation decreases linearly with the logarithm of the frequency in the range.

The following table is the setting of the receiver

| Receiver Parameters | Setting |
|---------------------|----------|
| Attenuation | 10 dB |
| Start Frequency | 0.15 MHz |
| Stop Frequency | 30 MHz |
| IF Bandwidth | 9 kHz |

3.1.2 TEST PROCEDURE

- a. The EUT was 0.8 meters from the horizontal ground plane and 0.4 meters from the vertical ground plane with EUT being connected to the power mains through a line impedance stabilization network (LISN). All other support equipments powered from additional LISN(s). The LISN provide 50 Ohm/ 50uH of coupling impedance for the measuring instrument.
- b. Interconnecting cables that hang closer than 40 cm to the ground plane shall be folded back and forth in the center forming a bundle 30 to 40 cm long.
- c. I/O cables that are not connected to a peripheral shall be bundled in the center. The end of the cable may be terminated, if required, using the correct terminating impedance. The overall length shall not exceed 1 m.
- d. LISN at least 80 cm from nearest part of EUT chassis.
- e. For the actual test configuration, please refer to the related Item –EUT Test Photos.

3.1.3 TEST SETUP

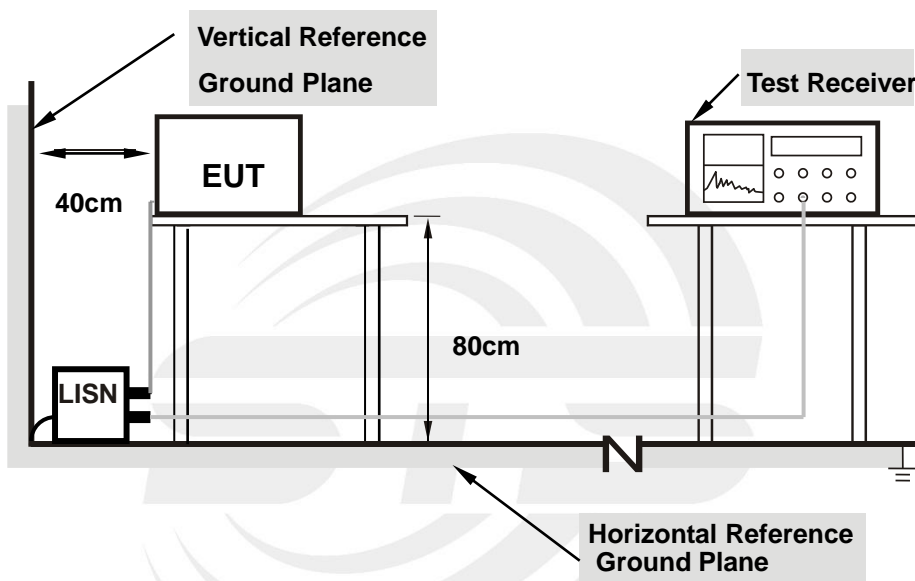

- Note: 1.Support units were connected to second LISN.**
2.Both of LISNs (AMN) are 80 cm from EUT and at least 80 from other units and other metal planes

3.1.4 EUT OPERATING CONDITIONS

The EUT was configured for testing in a typical fashion (as a customer would normally use it). The EUT has been programmed to continuously transmit during test. This operating condition was tested and used to collect the included data.



3.1.5 TEST RESULT

| | | | |
|---------------|--------------|--------------------|-------|
| Temperature: | 23.1(C) | Relative Humidity: | 46%RH |
| Test Voltage: | AC 120V/60Hz | Phase: | L |
| Test Mode: | Mode 10(TX) | | |

| No. | Frequency (MHz) | Reading (dBuV) | Correct Factor(dB) | Result (dBuV) | Limit (dBuV) | Margin (dB) | Remark |
|-----|-----------------|----------------|--------------------|---------------|--------------|-------------|--------|
| 1 | 0.1660 | 32.53 | 19.76 | 52.29 | 65.16 | -12.87 | QP |
| 2 | 0.1660 | 13.29 | 19.76 | 33.05 | 55.16 | -22.11 | AVG |
| 3 | 0.6060 | 28.85 | 19.89 | 48.74 | 56.00 | -7.26 | QP |
| 4 | 0.6060 | 18.72 | 19.89 | 38.61 | 46.00 | -7.39 | AVG |
| 5 | 1.8060 | 24.05 | 19.73 | 43.78 | 56.00 | -12.22 | QP |
| 6 | 1.8060 | 13.44 | 19.73 | 33.17 | 46.00 | -12.83 | AVG |
| 7 | 3.7740 | 22.56 | 19.77 | 42.33 | 56.00 | -13.67 | QP |
| 8 | 3.7740 | 11.70 | 19.77 | 31.47 | 46.00 | -14.53 | AVG |
| 9 | 13.0340 | 20.86 | 20.10 | 40.96 | 60.00 | -19.04 | QP |
| 10 | 13.0340 | 10.50 | 20.10 | 30.60 | 50.00 | -19.40 | AVG |
| 11 | 20.6780 | 23.55 | 20.25 | 43.80 | 60.00 | -16.20 | QP |
| 12 | 20.6780 | 12.98 | 20.25 | 33.23 | 50.00 | -16.77 | AVG |

Remark:

1. All readings are Quasi-Peak and Average values.
2. Margin = Result (Result =Reading + Factor)–Limit

100.0 dBuV

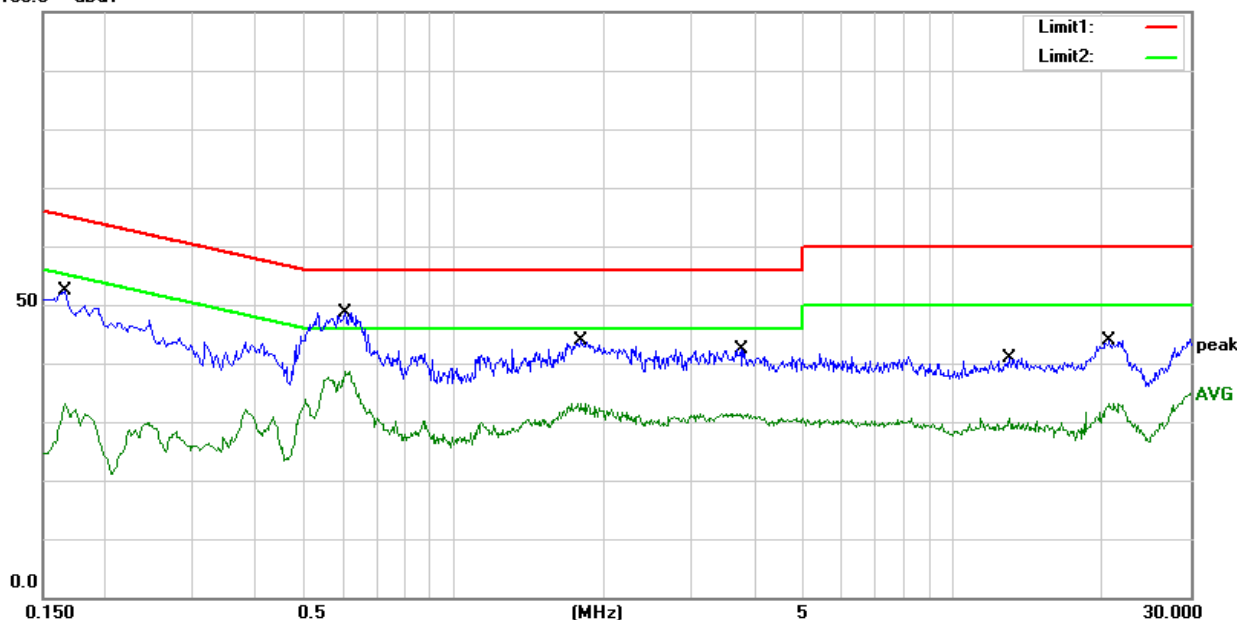



| | | | |
|---------------|--------------|--------------------|-------|
| Temperature: | 23.1(C) | Relative Humidity: | 46%RH |
| Test Voltage: | AC 120V/60Hz | Phase: | N |
| Test Mode: | Mode 10(TX) | | |

| No. | Frequency (MHz) | Reading (dBuV) | Correct Factor(dB) | Result (dBuV) | Limit (dBuV) | Margin (dB) | Remark |
|-----|-----------------|----------------|--------------------|---------------|--------------|-------------|--------|
| 1 | 0.1580 | 29.97 | 19.76 | 49.73 | 65.57 | -15.84 | QP |
| 2 | 0.1580 | 11.50 | 19.76 | 31.26 | 55.57 | -24.31 | AVG |
| 3 | 0.5380 | 31.06 | 19.95 | 51.01 | 56.00 | -4.99 | QP |
| 4 | 0.5380 | 20.20 | 19.95 | 40.15 | 46.00 | -5.85 | AVG |
| 5 | 1.5620 | 21.85 | 19.74 | 41.59 | 56.00 | -14.41 | QP |
| 6 | 1.5620 | 11.11 | 19.74 | 30.85 | 46.00 | -15.15 | AVG |
| 7 | 4.4140 | 19.42 | 19.77 | 39.19 | 56.00 | -16.81 | QP |
| 8 | 4.4140 | 10.56 | 19.77 | 30.33 | 46.00 | -15.67 | AVG |
| 9 | 20.8660 | 22.90 | 20.23 | 43.13 | 60.00 | -16.87 | QP |
| 10 | 20.8660 | 12.09 | 20.23 | 32.32 | 50.00 | -17.68 | AVG |
| 11 | 29.3100 | 23.75 | 20.05 | 43.80 | 60.00 | -16.20 | QP |
| 12 | 29.3100 | 14.72 | 20.05 | 34.77 | 50.00 | -15.23 | AVG |

Remark:

1. All readings are Quasi-Peak and Average values.
2. Margin = Result (Result = Reading + Factor) – Limit

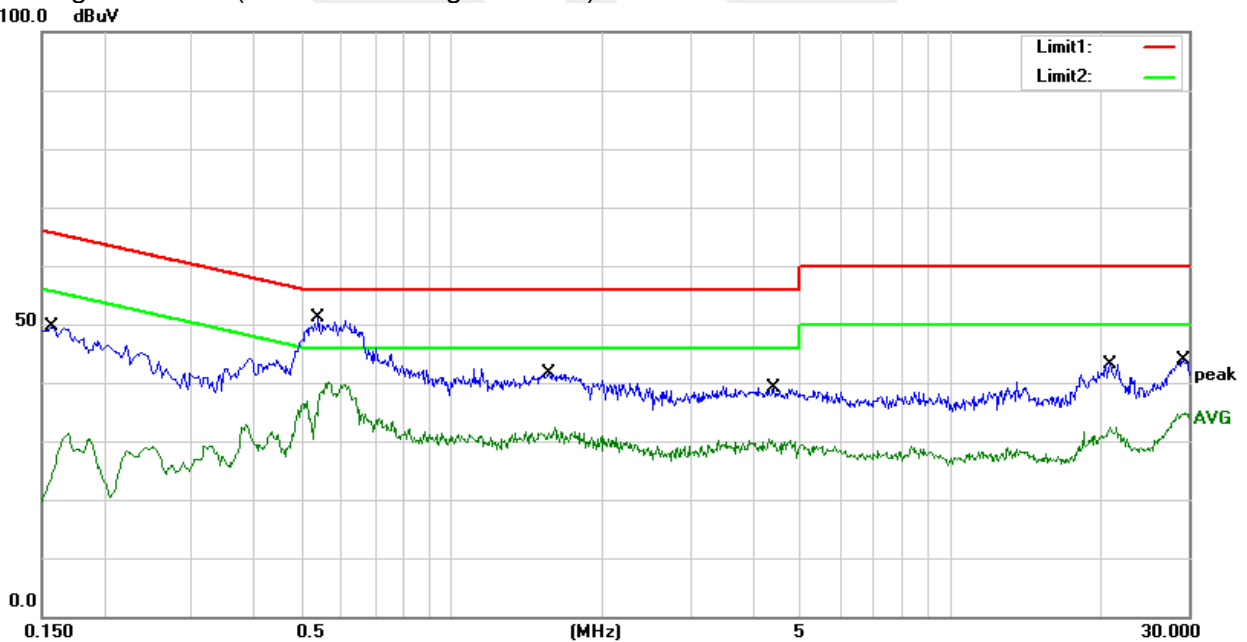



| | | | |
|---------------|--------------|--------------------|-------|
| Temperature: | 23.1(C) | Relative Humidity: | 46%RH |
| Test Voltage: | AC 120V/60Hz | Phase: | L |
| Test Mode: | RX Mode | | |

| No. | Frequency (MHz) | Reading (dBuV) | Correct Factor(dB) | Result (dBuV) | Limit (dBuV) | Margin (dB) | Remark |
|-----|-----------------|----------------|--------------------|---------------|--------------|-------------|--------|
| 1 | 0.1675 | 29.97 | 19.76 | 49.73 | 65.08 | -15.35 | QP |
| 2 | 0.1675 | 11.84 | 19.76 | 31.60 | 55.08 | -23.48 | AVG |
| 3 | 0.5340 | 28.08 | 19.96 | 48.04 | 56.00 | -7.96 | QP |
| 4 | 0.5340 | 16.72 | 19.96 | 36.68 | 46.00 | -9.32 | AVG |
| 5 | 1.8060 | 24.05 | 19.73 | 43.78 | 56.00 | -12.22 | QP |
| 6 | 1.8060 | 13.44 | 19.73 | 33.17 | 46.00 | -12.83 | AVG |
| 7 | 3.6860 | 23.07 | 19.76 | 42.83 | 56.00 | -13.17 | QP |
| 8 | 3.6860 | 12.21 | 19.76 | 31.97 | 46.00 | -14.03 | AVG |
| 9 | 8.9740 | 20.50 | 20.00 | 40.50 | 60.00 | -19.50 | QP |
| 10 | 8.9740 | 10.20 | 20.00 | 30.20 | 50.00 | -19.80 | AVG |
| 11 | 21.8860 | 23.62 | 20.17 | 43.79 | 60.00 | -16.21 | QP |
| 12 | 21.8860 | 13.02 | 20.17 | 33.19 | 50.00 | -16.81 | AVG |

Remark:

1. All readings are Quasi-Peak and Average values.
2. Margin = Result (Result = Reading + Factor) – Limit

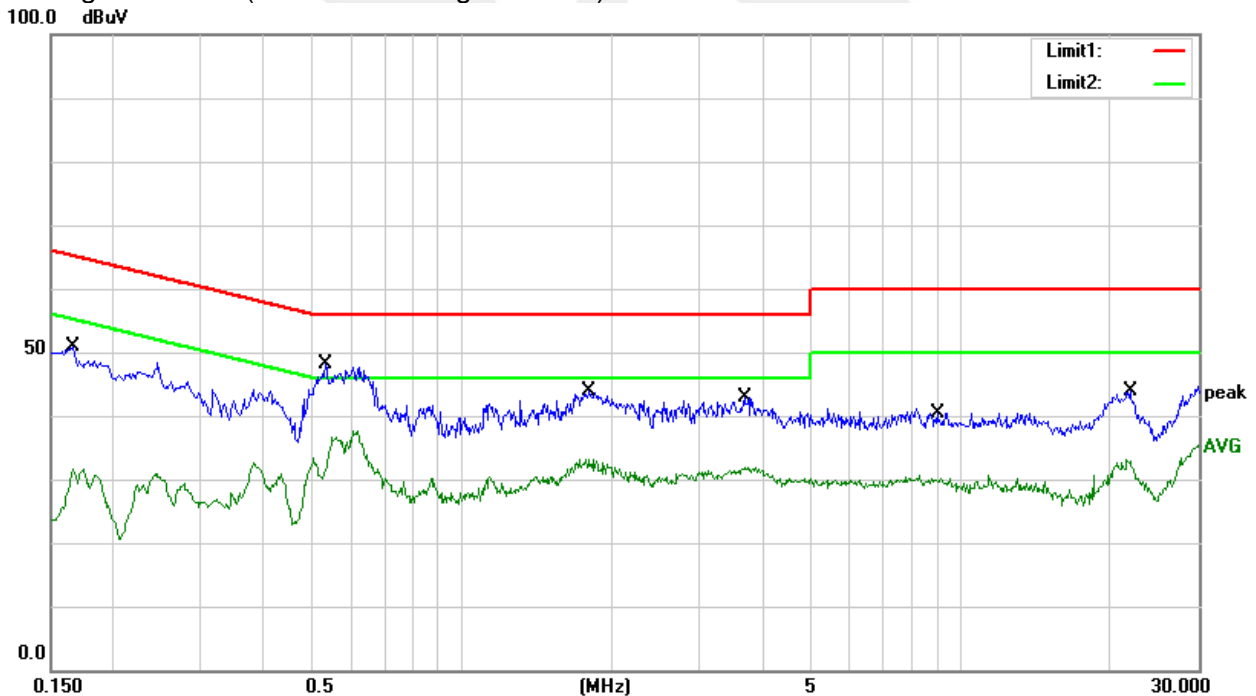



| | | | |
|---------------|--------------|--------------------|-------|
| Temperature: | 23.1(C) | Relative Humidity: | 46%RH |
| Test Voltage: | AC 120V/60Hz | Phase: | N |
| Test Mode: | RX Mode | | |

| No. | Frequency (MHz) | Reading (dBuV) | Correct Factor(dB) | Result (dBuV) | Limit (dBuV) | Margin (dB) | Remark |
|-----|-----------------|----------------|--------------------|---------------|--------------|-------------|--------|
| 1 | 0.1580 | 28.97 | 19.76 | 48.73 | 65.57 | -16.84 | QP |
| 2 | 0.1580 | 10.50 | 19.76 | 30.26 | 55.57 | -25.31 | AVG |
| 3 | 0.6100 | 30.13 | 19.89 | 50.02 | 56.00 | -5.98 | QP |
| 4 | 0.6100 | 19.76 | 19.89 | 39.65 | 46.00 | -6.35 | AVG |
| 5 | 1.4980 | 21.76 | 19.74 | 41.50 | 56.00 | -14.50 | QP |
| 6 | 1.4980 | 13.02 | 19.74 | 32.76 | 46.00 | -13.24 | AVG |
| 7 | 3.5060 | 20.05 | 19.76 | 39.81 | 56.00 | -16.19 | QP |
| 8 | 3.5060 | 10.84 | 19.76 | 30.60 | 46.00 | -15.40 | AVG |
| 9 | 9.4620 | 18.54 | 20.05 | 38.59 | 60.00 | -21.41 | QP |
| 10 | 9.4620 | 9.01 | 20.05 | 29.06 | 50.00 | -20.94 | AVG |
| 11 | 20.8660 | 23.90 | 20.23 | 44.13 | 60.00 | -15.87 | QP |
| 12 | 20.8660 | 13.09 | 20.23 | 33.32 | 50.00 | -16.68 | AVG |

Remark:

1. All readings are Quasi-Peak and Average values.
2. Margin = Result (Result = Reading + Factor) – Limit

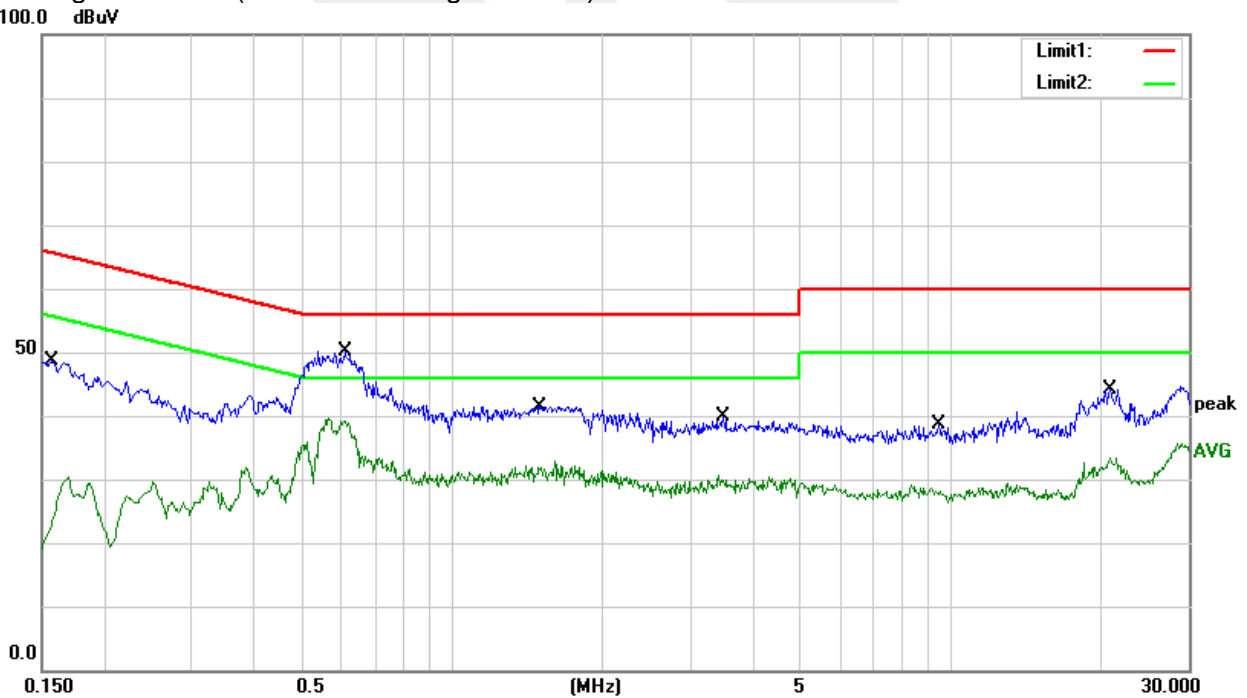



3.2 RADIATED EMISSION MEASUREMENT

3.2.1 RADIATED EMISSION LIMITS

In any 100 kHz bandwidth outside the operating frequency band. In case the emission fall within the Restricted band specified on Part15.205(a)&209(a), RSS-Gen Issue 5, Amendment 1, March 2019 and RSS-247 Issue 2, February 2017 (5.5) limit in the table and according to ANSI C63.10-2013 below has to be followed.

LIMITS OF RADIATED EMISSION MEASUREMENT (0.009MHz - 1000MHz)

| Frequencies (MHz) | Field Strength (micorvolts/meter) | Measurement Distance (meters) |
|-------------------|-----------------------------------|-------------------------------|
| 0.009~0.490 | 2400/F(KHz) | 300 |
| 0.490~1.705 | 24000/F(KHz) | 30 |
| 1.705~30.0 | 30 | 30 |
| 30~88 | 100 | 3 |
| 88~216 | 150 | 3 |
| 216~960 | 200 | 3 |
| Above 960 | 500 | 3 |

LIMITS OF RADIATED EMISSION MEASUREMENT (1GHz-25 GHz)

| FREQUENCY (MHz) | (dBuV/m) (at 3M) | |
|-----------------|------------------|---------|
| | PEAK | AVERAGE |
| Above 1000 | 74 | 54 |

Notes:

- (1) The limit for radiated test was performed according to FCC PART 15C.
- (2) The tighter limit applies at the band edges.
- (3) Emission level (dBuV/m)=20log Emission level (uV/m).

LIMITS OF RESTRICTED FREQUENCY BANDS

FCC:

| FREQUENCY (MHz) | FREQUENCY (MHz) | FREQUENCY (MHz) | FREQUENCY (GHz) |
|-------------------|---------------------|-----------------|-----------------|
| 0.090-0.110 | 16.42-16.423 | 399.9-410 | 4.5-5.15 |
| 0.495-0.505 | 16.69475-16.69525 | 608-614 | 5.35-5.46 |
| 2.1735-2.1905 | 16.80425-16.80475 | 960-1240 | 7.25-7.75 |
| 4.125-4.128 | 25.5-25.67 | 1300-1427 | 8.025-8.5 |
| 4.17725-4.17775 | 37.5-38.25 | 1435-1626.5 | 9.0-9.2 |
| 4.20725-4.20775 | 73-74.6 | 1645.5-1646.5 | 9.3-9.5 |
| 6.215-6.218 | 74.8-75.2 | 1660-1710 | 10.6-12.7 |
| 6.26775-6.26825 | 108-121.94 | 1718.8-1722.2 | 13.25-13.4 |
| 6.31175-6.31225 | 123-138 | 2200-2300 | 14.47-14.5 |
| 8.291-8.294 | 149.9-150.05 | 2310-2390 | 15.35-16.2 |
| 8.362-8.366 | 156.52475-156.52525 | 2483.5-2500 | 17.7-21.4 |
| 8.37625-8.38675 | 156.7-156.9 | 2690-2900 | 22.01-23.12 |
| 8.41425-8.41475 | 162.0125-167.17 | 3260-3267 | 23.6-24.0 |
| 12.29-12.293 | 167.72-173.2 | 3332-3339 | 31.2-31.8 |
| 12.51975-12.52025 | 240-285 | 3345.8-3358 | 36.43-36.5 |
| 12.57675-12.57725 | 322-335.4 | 3600-4400 | Above 38.6 |
| 13.36-13.41 | | | |



IC:

| FREQUENCY (MHz) | FREQUENCY (MHz) | FREQUENCY (GHz) |
|---------------------|-----------------------|-----------------|
| 0.090 - 0.110 | 149.9 - 150.05 | 9.0 - 9.2 |
| 0.495 - 0.505 | 156.52475 - 156.52525 | 9.3 - 9.5 |
| 2.1735 - 2.1905 | 156.7 - 156.9 | 10.6 - 12.7 |
| 3.020 - 3.026 | 162.0125 - 167.17 | 13.25 - 13.4 |
| 4.125 - 4.128 | 167.72 - 173.2 | 14.47 - 14.5 |
| 4.17725 - 4.17775 | 240 - 285 | 15.35 - 16.2 |
| 4.20725 - 4.20775 | 322 - 335.4 | 17.7 - 21.4 |
| 5.677 - 5.683 | 399.9 - 410 | 22.01 - 23.12 |
| 6.215 - 6.218 | 608 - 614 | 23.6 - 24.0 |
| 6.26775 - 6.26825 | 960 - 1427 | 31.2 - 31.8 |
| 6.31175 - 6.31225 | 1435 - 1626.5 | 36.43 - 36.5 |
| 8.291 - 8.294 | 1645.5 - 1646.5 | Above 38.6 |
| 8.362 - 8.366 | 1660 - 1710 | |
| 8.37625 - 8.38675 | 1718.8 - 1722.2 | |
| 8.41425 - 8.41475 | 2200 - 2300 | |
| 12.29 - 12.293 | 2310 - 2390 | |
| 12.51975 - 12.52025 | 2483.5 - 2500 | |
| 12.57675 - 12.57725 | 2655 - 2900 | |
| 13.36 - 13.41 | 3260 - 3267 | |
| 16.42 - 16.423 | 3332 - 3339 | |
| 16.69475 - 16.69525 | 3345.8 - 3358 | |
| 16.80425 - 16.80475 | 3500 - 4400 | |
| 25.5 - 25.67 | 4500 - 5150 | |
| 37.5 - 38.25 | 5350 - 5460 | |
| 73 - 74.6 | 7250 - 7750 | |
| 74.8 - 75.2 | 8025 - 8500 | |
| 108 - 138 | | |



For Radiated Emission

| Spectrum Parameter | Setting |
|---------------------------------------|---|
| Attenuation | Auto |
| Detector | Peak/QP/AV |
| Start Frequency | 9 KHz/150KHz(Peak/QP/AV) |
| Stop Frequency | 150KHz/30MHz(Peak/QP/AV) |
| RB / VB (emission in restricted band) | 200Hz (From 9kHz to 0.15MHz)/ 9KHz (From 0.15MHz to 30MHz); 200Hz (From 9kHz to 0.15MHz)/ 9KHz (From 0.15MHz to 30MHz) |

| Spectrum Parameter | Setting |
|---------------------------------------|--------------------|
| Attenuation | Auto |
| Detector | Peak/QP |
| Start Frequency | 30 MHz(Peak/QP) |
| Stop Frequency | 1000 MHz (Peak/QP) |
| RB / VB (emission in restricted band) | 120 KHz / 300 KHz |

| Spectrum Parameter | Setting |
|---------------------------------------|---|
| Attenuation | Auto |
| Detector | Peak/AV |
| Start Frequency | 1000 MHz(Peak/AV) |
| Stop Frequency | 10th carrier hamonic(Peak/AV) |
| RB / VB (emission in restricted band) | 1 MHz / 3 MHz(Peak) 1 MHz/1/T MHz(AVG) |

For Restricted band

| Spectrum Parameter | Setting |
|----------------------|--|
| Detector | Peak/AV |
| Start/Stop Frequency | Lower Band Edge: 2310 to 2410 MHz Upper Band Edge: 2476 to 2500 MHz |
| RB / VB | 1 MHz / 3 MHz(Peak) 1 MHz/1/T MHz(AVG) |

| Receiver Parameter | Setting |
|------------------------|--------------------------------------|
| Attenuation | Auto |
| Start ~ Stop Frequency | 9kHz~90kHz / RB 200Hz for PK & AV |
| Start ~ Stop Frequency | 90kHz~110kHz / RB 200Hz for QP |
| Start ~ Stop Frequency | 110kHz~490kHz / RB 200Hz for PK & AV |
| Start ~ Stop Frequency | 490kHz~30MHz / RB 9kHz for QP |
| Start ~ Stop Frequency | 30MHz~1000MHz / RB 120kHz for QP |

3.2.2 TEST PROCEDURE

- The measuring distance of at 3 m shall be used for measurements at frequency 0.009MHz up to 1GHz, and above 1GHz.
- The EUT was placed on the top of a rotating table 0.8 meters (above 1GHz is 1.5 m) above the ground at a 3 meter anechoic chamber test site. The table was rotated 360 degrees to determine the position of the highest radiation.
- The height of the equipment shall be 0.8 m (above 1GHz is 1.5 m); the height of the test antenna shall vary between 1 m to 4 m. horizontal and vertical polarizations of the antenna are set to make the measurement.
- The initial step in collecting conducted emission data is a spectrum analyzer peak detector mode pre-scanning the measurement frequency range. Significant peaks are then marked and then QuasiPeak detector mode re-measured.
- If the Peak Mode measured value compliance with and lower than Quasi Peak Mode Limit, the EUT shall be deemed to meet QP Limits and then no additional QP Mode measurement performed.
- For the actual test configuration, please refer to the related Item –EUT Test Photos.

Note:

Both horizontal and vertical antenna polarities were tested and performed pretest to three orthogonal axis. The worst case emissions were reported.

3.2.3 DEVIATION FROM TEST STANDARD

No deviation.

3.2.4 TESTSETUP

(A) Radiated Emission Test-Up Frequency Below 30MHz

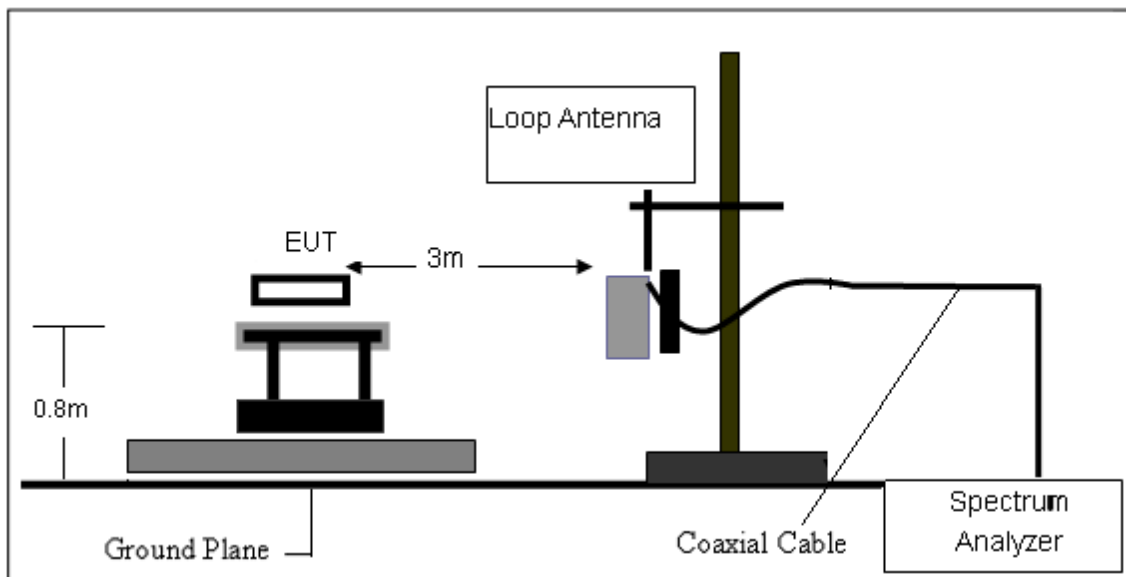

(B) Radiated Emission Test-Up Frequency 30MHz~1GHz

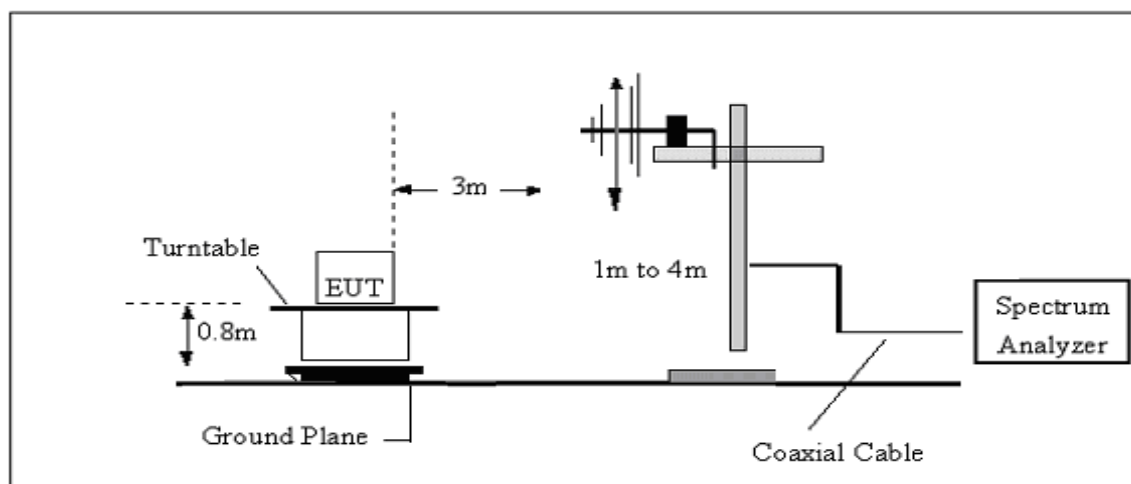

(C) Radiated Emission Test-Up Frequency Above 1GHz

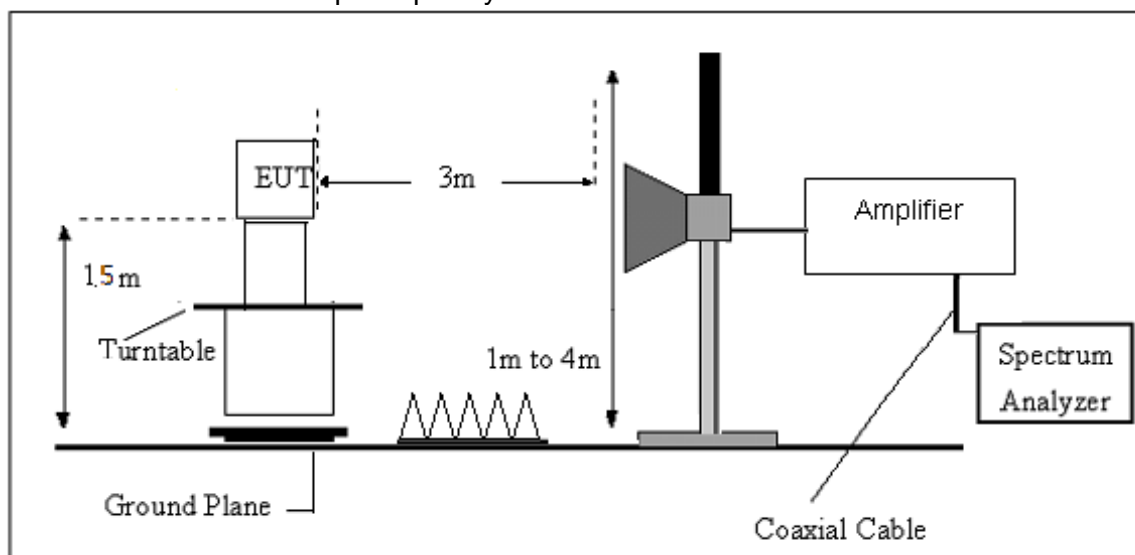

3.2.5 EUT OPERATING CONDITIONS

The EUT tested system was configured as the statements of 2.4 Unless otherwise a special operating condition is specified in the follows during the testing.



3.2.6 FIELD STRENGTH CALCULATION

The field strength is calculated by adding the Antenna Factor and Cable Factor and subtracting the Amplifier Gain and Duty Cycle Correction Factor (if any) from the measured reading. The basic equation with a sample calculation is as follows:

$$FS = RA + AF + CL - AG$$

Where

FS = Field Strength

CL = Cable Attenuation Factor (Cable Loss)

RA = Reading Amplitude

AG = Amplifier Gain

AF = Antenna Factor

For example

| Frequency (MHz) | FS (dB μ V/m) | RA (dB μ V/m) | AF (dB) | CL (dB) | AG (dB) | Factor (dB) |
|--------------------|----------------------|----------------------|------------|------------|------------|----------------|
| 300 | 40 | 58.1 | 12.2 | 1.6 | 31.9 | -18.1 |

$$\text{Factor} = \text{AF} + \text{CL} - \text{AG}$$





3.2.7 TEST RESULTS

(9KHz-30MHz)

| | | | |
|---------------|----------------------|--------------------|---------|
| Temperature: | 22.7(C) | Relative Humidity: | 61%RH |
| Test Voltage: | DC 7.4V from battery | Test Mode: | TX Mode |

| Freq. (MHz) | Reading (dBuV/m) | Limit (dBuV/m) | Margin (dB) | State P/F | Test Result |
|----------------|---------------------|-------------------|----------------|--------------|-------------|
| -- | -- | -- | -- | -- | PASS |
| -- | -- | -- | -- | -- | PASS |

Note:

The amplitude of spurious emissions which are attenuated by more than 20dB below the permissible value has no need to be reported.

Distance extrapolation factor = $40 \log(\text{specific distance/test distance})$ (dB);

Limit line = specific limits (dBuV) + distance extrapolation factor.



(30MHz-1000MHz)

| | | | |
|---------------|--|--------------------|------------|
| Temperature: | 22.7(C) | Relative Humidity: | 61%RH |
| Test Voltage: | DC 7.4V from battery | Phase: | Horizontal |
| Test Mode: | TX Mode 1/2/3/4/5/6/7/8/9(Mode 5 worst mode) | | |

| No. | Frequency (MHz) | Reading (dBuV) | Correct Factor(dB) | Result (dBuV) | Limit (dBuV) | Margin (dB) | Remark |
|-----|-----------------|----------------|--------------------|---------------|--------------|-------------|--------|
| 1 | 30.0000 | 28.34 | -12.85 | 15.49 | 40.00 | -24.51 | QP |
| 2 | 159.0100 | 42.80 | -18.77 | 24.03 | 43.50 | -19.47 | QP |
| 3 | 321.9700 | 45.10 | -13.94 | 31.16 | 46.00 | -14.84 | QP |
| 4 | 546.0400 | 43.13 | -6.20 | 36.93 | 46.00 | -9.07 | QP |
| 5 | 835.1000 | 29.46 | -0.54 | 28.92 | 46.00 | -17.08 | QP |
| 6 | 960.2300 | 31.67 | 1.76 | 33.43 | 54.00 | -20.57 | QP |

Remark:

1. Margin = Result (Result =Reading + Factor)–Limit

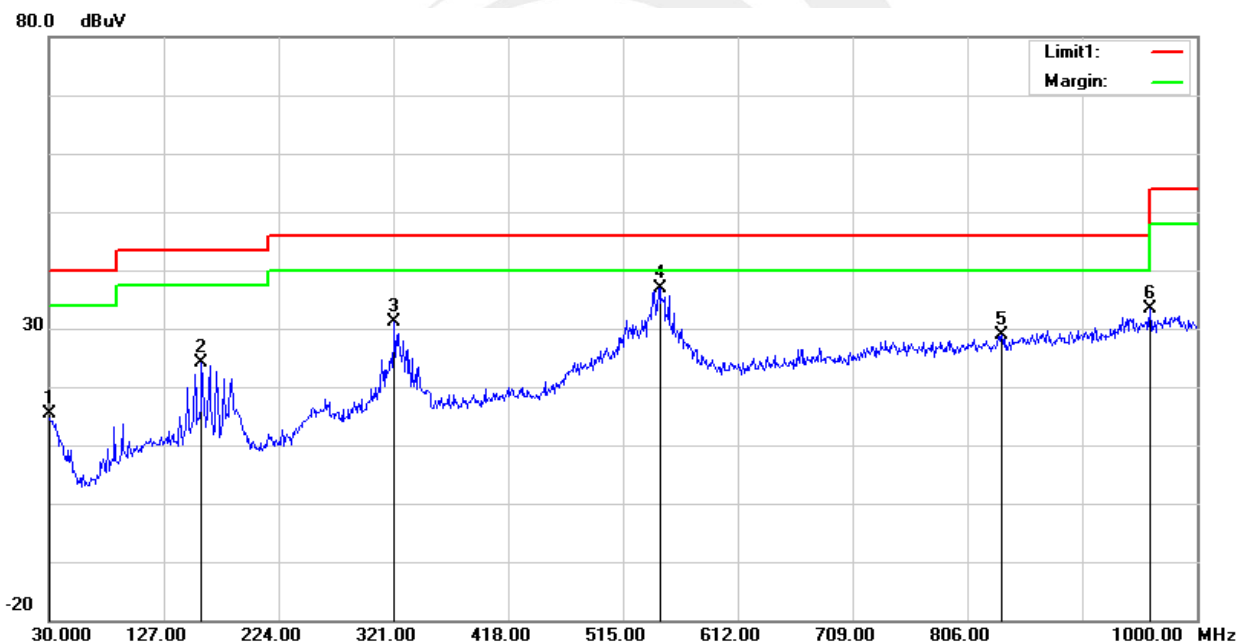



| | | | |
|---------------|--|--------------------|----------|
| Temperature: | 22.7(C) | Relative Humidity: | 61%RH |
| Test Voltage: | DC 7.4V from battery | Phase: | Vertical |
| Test Mode: | TX Mode 1/2/3/4/5/6/7/8/9(Mode 5 worst mode) | | |

| No. | Frequency (MHz) | Reading (dBuV) | Correct Factor(dB) | Result (dBuV) | Limit (dBuV) | Margin (dB) | Remark |
|-----|-----------------|----------------|--------------------|---------------|--------------|-------------|--------|
| 1 | 30.0000 | 28.30 | -12.85 | 15.45 | 40.00 | -24.55 | QP |
| 2 | 190.0500 | 39.76 | -20.97 | 18.79 | 43.50 | -24.71 | QP |
| 3 | 255.0400 | 35.98 | -15.35 | 20.63 | 46.00 | -25.37 | QP |
| 4 | 543.1300 | 38.66 | -6.52 | 32.14 | 46.00 | -13.86 | QP |
| 5 | 867.1100 | 29.95 | -0.50 | 29.45 | 46.00 | -16.55 | QP |
| 6 | 979.6300 | 29.40 | 2.65 | 32.05 | 54.00 | -21.95 | QP |

Remark:

1. Margin = Result (Result =Reading + Factor)–Limit

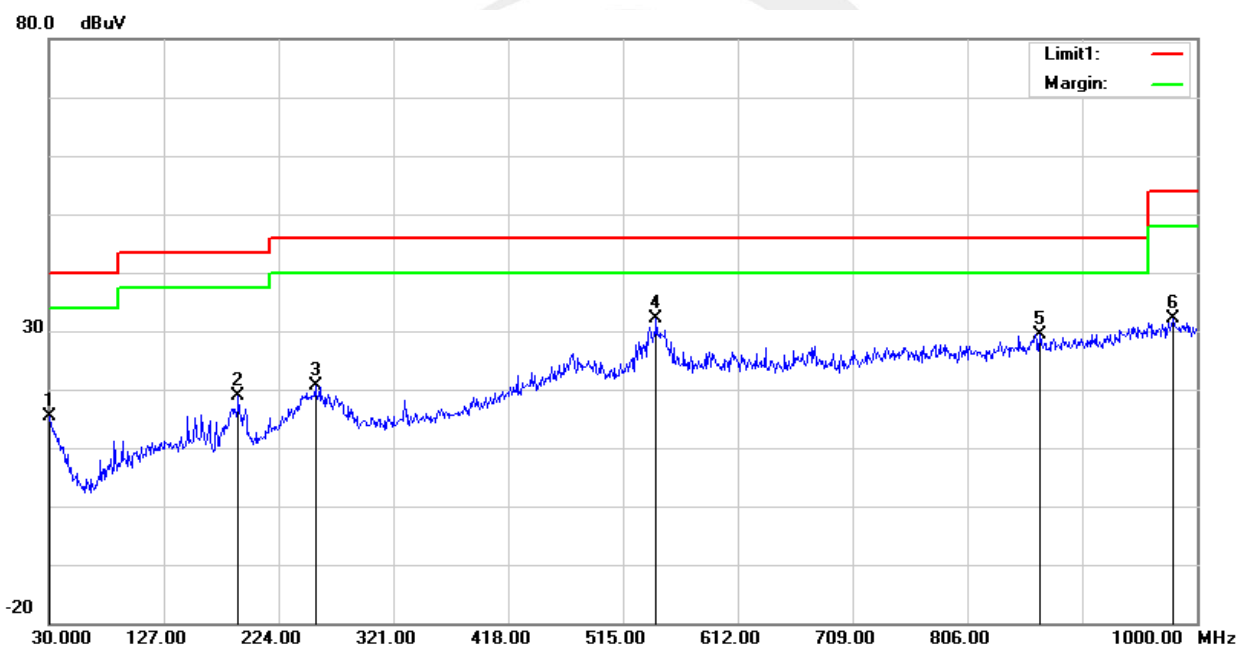



| | | | |
|---------------|--|--------------------|------------|
| Temperature: | 22.9(C) | Relative Humidity: | 57%RH |
| Test Voltage: | DC 7.4V from battery | Phase: | Horizontal |
| Test Mode: | RX Mode 1/2/3/4/5/6/7/8/9(Mode 5 worst mode) | | |

| Frequency (MHz) | Peak Level (dBuV/m) | Q-peak Level (dBuV/m) | Average Level (dBuV/m) | Factor (dB) | PK Limit (dBuV/m) | QP Limit (dBuV/m) | AV Limit (dBuV/m) | Over Limit (dB) | ANT | Verdict |
|-----------------|---------------------|-----------------------|------------------------|-------------|-------------------|-------------------|-------------------|-----------------|------------|---------|
| 30.727 | 13.26 | -- | -- | -12.37 | -- | 40.0 | -- | -26.74 | Horizontal | Pass |
| 127.970 | 12.85 | -- | -- | -16.84 | -- | 43.5 | -- | -30.65 | Horizontal | Pass |
| 251.645 | 14.09 | -- | -- | -13.95 | -- | 46.0 | -- | -31.91 | Horizontal | Pass |
| 479.353 | 22.57 | -- | -- | -6.33 | -- | 46.0 | -- | -23.43 | Horizontal | Pass |
| 854.015 | 31.45 | -- | -- | 2.59 | -- | 46.0 | -- | -14.55 | Horizontal | Pass |
| 974.295 | 33.34 | -- | -- | 5.64 | -- | 54.0 | -- | -20.66 | Horizontal | Pass |

Remark:

1. Margin = Result (Result =Reading + Factor)–Limit

RE_IC Test Case_RSS 30MHz-1GHz

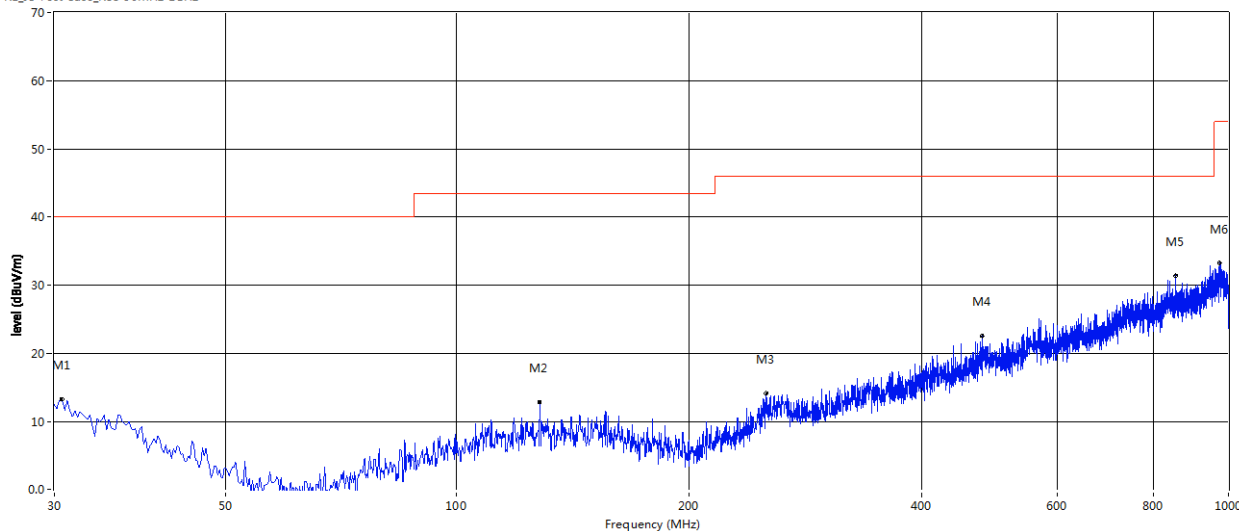



| | | | |
|---------------|--|--------------------|----------|
| Temperature: | 22.9(C) | Relative Humidity: | 57%RH |
| Test Voltage: | DC 7.4V from battery | Phase: | Vertical |
| Test Mode: | RX Mode 1/2/3/4/5/6/7/8/9(Mode 5 worst mode) | | |

| Frequency (MHz) | Peak Level (dBuV/m) | Q-peak Level (dBuV/m) | Average Level (dBuV/m) | Factor (dB) | PK Limit (dBuV/m) | QP Limit (dBuV/m) | AV Limit (dBuV/m) | Over Limit (dB) | ANT | Verdict |
|-----------------|---------------------|-----------------------|------------------------|-------------|-------------------|-------------------|-------------------|-----------------|----------|---------|
| 30.970 | 13.20 | -- | -- | -12.50 | -- | 40.0 | -- | -26.80 | Vertical | Pass |
| 131.365 | 11.09 | -- | -- | -16.81 | -- | 43.5 | -- | -32.41 | Vertical | Pass |
| 267.408 | 14.96 | -- | -- | -13.06 | -- | 46.0 | -- | -31.04 | Vertical | Pass |
| 559.377 | 25.42 | -- | -- | -2.97 | -- | 46.0 | -- | -20.58 | Vertical | Pass |
| 828.795 | 30.51 | -- | -- | 2.25 | -- | 46.0 | -- | -15.49 | Vertical | Pass |
| 982.540 | 34.50 | -- | -- | 5.87 | -- | 54.0 | -- | -19.50 | Vertical | Pass |

Remark:

1. Margin = Result (Result =Reading + Factor)–Limit

RE_IC Test Case_RSS 30MHz-1GHz

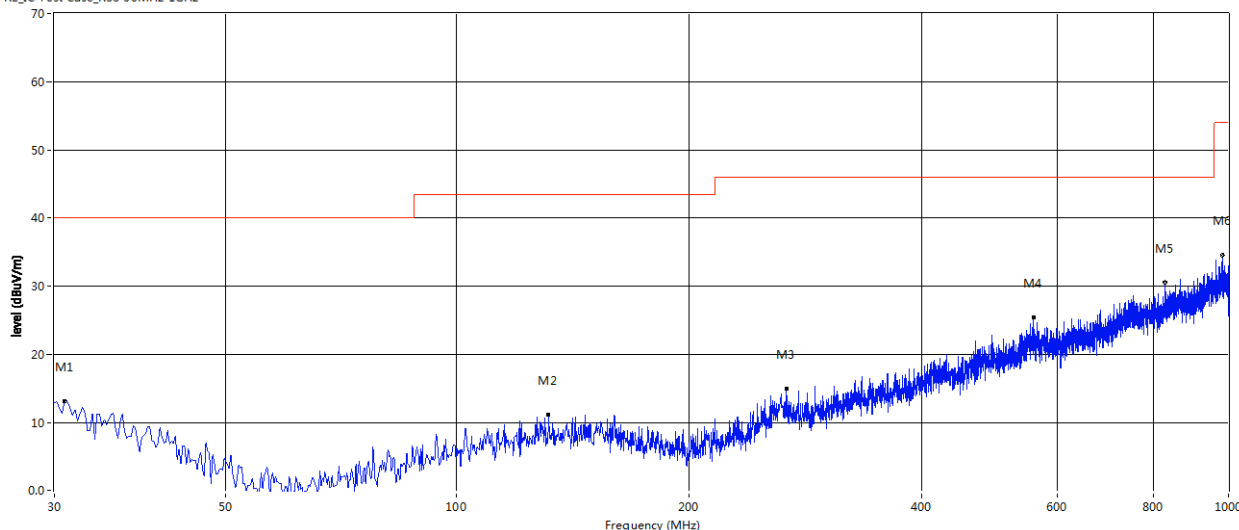



(1GHz~25GHz) Spurious emission Requirements

TX Mode

| Frequency (MHz) | Meter Reading (dBμV) | Amplifier (dB) | Loss (dB) | Antenna Factor (dB/m) | Orrected Factor (dB) | Emission Level (dBμV/m) | Limits (dBμV/m) | Margin (dB) | Detector Type | Comment |
|-------------------------------------|-------------------------|-------------------|--------------|--------------------------|-------------------------|----------------------------|--------------------|----------------|------------------|------------|
| Low Channel (π/4-DQPSK/2402 MHz) | | | | | | | | | | |
| 3264.66 | 60.92 | 44.70 | 6.70 | 28.20 | -9.80 | 51.12 | 74.00 | -22.88 | PK | Vertical |
| 3264.66 | 49.83 | 44.70 | 6.70 | 28.20 | -9.80 | 40.03 | 54.00 | -13.97 | AV | Vertical |
| 3264.76 | 61.47 | 44.70 | 6.70 | 28.20 | -9.80 | 51.67 | 74.00 | -22.33 | PK | Horizontal |
| 3264.76 | 50.73 | 44.70 | 6.70 | 28.20 | -9.80 | 40.93 | 54.00 | -13.07 | AV | Horizontal |
| 4804.33 | 59.08 | 44.20 | 9.04 | 31.60 | -3.56 | 55.52 | 74.00 | -18.48 | PK | Vertical |
| 4804.33 | 49.95 | 44.20 | 9.04 | 31.60 | -3.56 | 46.39 | 54.00 | -7.61 | AV | Vertical |
| 4804.41 | 59.12 | 44.20 | 9.04 | 31.60 | -3.56 | 55.56 | 74.00 | -18.44 | PK | Horizontal |
| 4804.41 | 50.04 | 44.20 | 9.04 | 31.60 | -3.56 | 46.48 | 54.00 | -7.52 | AV | Horizontal |
| 5359.70 | 49.39 | 44.20 | 9.86 | 32.00 | -2.34 | 47.05 | 74.00 | -26.95 | PK | Vertical |
| 5359.70 | 39.75 | 44.20 | 9.86 | 32.00 | -2.34 | 37.41 | 54.00 | -16.59 | AV | Vertical |
| 5359.73 | 47.53 | 44.20 | 9.86 | 32.00 | -2.34 | 45.19 | 74.00 | -28.81 | PK | Horizontal |
| 5359.73 | 38.93 | 44.20 | 9.86 | 32.00 | -2.34 | 36.59 | 54.00 | -17.41 | AV | Horizontal |
| 7205.91 | 54.53 | 43.50 | 11.40 | 35.50 | 3.40 | 57.93 | 74.00 | -16.07 | PK | Vertical |
| 7205.91 | 43.95 | 43.50 | 11.40 | 35.50 | 3.40 | 47.35 | 54.00 | -6.65 | AV | Vertical |
| 7205.66 | 54.81 | 43.50 | 11.40 | 35.50 | 3.40 | 58.21 | 74.00 | -15.79 | PK | Horizontal |
| 7205.66 | 43.64 | 43.50 | 11.40 | 35.50 | 3.40 | 47.04 | 54.00 | -6.96 | AV | Horizontal |
| Middle Channel (π/4-DQPSK/2441 MHz) | | | | | | | | | | |
| 3264.74 | 61.75 | 44.70 | 6.70 | 28.20 | -9.80 | 51.95 | 74.00 | -22.05 | PK | Vertical |
| 3264.74 | 51.70 | 44.70 | 6.70 | 28.20 | -9.80 | 41.90 | 54.00 | -12.10 | AV | Vertical |
| 3264.59 | 61.88 | 44.70 | 6.70 | 28.20 | -9.80 | 52.08 | 74.00 | -21.92 | PK | Horizontal |
| 3264.59 | 50.00 | 44.70 | 6.70 | 28.20 | -9.80 | 40.20 | 54.00 | -13.80 | AV | Horizontal |
| 4882.53 | 59.59 | 44.20 | 9.04 | 31.60 | -3.56 | 56.03 | 74.00 | -17.97 | PK | Vertical |
| 4882.53 | 50.20 | 44.20 | 9.04 | 31.60 | -3.56 | 46.64 | 54.00 | -7.36 | AV | Vertical |
| 4882.33 | 58.40 | 44.20 | 9.04 | 31.60 | -3.56 | 54.84 | 74.00 | -19.16 | PK | Horizontal |
| 4882.33 | 49.60 | 44.20 | 9.04 | 31.60 | -3.56 | 46.04 | 54.00 | -7.96 | AV | Horizontal |
| 5359.74 | 48.28 | 44.20 | 9.86 | 32.00 | -2.34 | 45.94 | 74.00 | -28.06 | PK | Vertical |
| 5359.74 | 40.07 | 44.20 | 9.86 | 32.00 | -2.34 | 37.73 | 54.00 | -16.27 | AV | Vertical |
| 5359.86 | 47.29 | 44.20 | 9.86 | 32.00 | -2.34 | 44.95 | 74.00 | -29.05 | PK | Horizontal |
| 5359.86 | 38.17 | 44.20 | 9.86 | 32.00 | -2.34 | 35.83 | 54.00 | -18.17 | AV | Horizontal |
| 7323.69 | 54.84 | 43.50 | 11.40 | 35.50 | 3.40 | 58.24 | 74.00 | -15.76 | PK | Vertical |
| 7323.69 | 44.65 | 43.50 | 11.40 | 35.50 | 3.40 | 48.05 | 54.00 | -5.95 | AV | Vertical |
| 7323.75 | 54.30 | 43.50 | 11.40 | 35.50 | 3.40 | 57.70 | 74.00 | -16.30 | PK | Horizontal |
| 7323.75 | 43.74 | 43.50 | 11.40 | 35.50 | 3.40 | 47.14 | 54.00 | -6.86 | AV | Horizontal |



| High Channel ($\pi/4$ -DQPSK/2480 MHz) | | | | | | | | | | |
|---|-------|-------|-------|-------|-------|-------|-------|--------|----|------------|
| 3264.78 | 61.17 | 44.70 | 6.70 | 28.20 | -9.80 | 51.37 | 74.00 | -22.63 | PK | Vertical |
| 3264.78 | 50.93 | 44.70 | 6.70 | 28.20 | -9.80 | 41.13 | 54.00 | -12.87 | AV | Vertical |
| 3264.60 | 61.62 | 44.70 | 6.70 | 28.20 | -9.80 | 51.82 | 74.00 | -22.18 | PK | Horizontal |
| 3264.60 | 50.60 | 44.70 | 6.70 | 28.20 | -9.80 | 40.80 | 54.00 | -13.20 | AV | Horizontal |
| 4960.43 | 59.01 | 44.20 | 9.04 | 31.60 | -3.56 | 55.45 | 74.00 | -18.55 | PK | Vertical |
| 4960.43 | 50.56 | 44.20 | 9.04 | 31.60 | -3.56 | 47.00 | 54.00 | -7.00 | AV | Vertical |
| 4960.59 | 59.34 | 44.20 | 9.04 | 31.60 | -3.56 | 55.78 | 74.00 | -18.22 | PK | Horizontal |
| 4960.59 | 49.14 | 44.20 | 9.04 | 31.60 | -3.56 | 45.58 | 54.00 | -8.42 | AV | Horizontal |
| 5359.82 | 48.84 | 44.20 | 9.86 | 32.00 | -2.34 | 46.50 | 74.00 | -27.50 | PK | Vertical |
| 5359.82 | 39.59 | 44.20 | 9.86 | 32.00 | -2.34 | 37.25 | 54.00 | -16.75 | AV | Vertical |
| 5359.80 | 47.87 | 44.20 | 9.86 | 32.00 | -2.34 | 45.53 | 74.00 | -28.47 | PK | Horizontal |
| 5359.80 | 38.59 | 44.20 | 9.86 | 32.00 | -2.34 | 36.25 | 54.00 | -17.75 | AV | Horizontal |
| 7439.87 | 54.16 | 43.50 | 11.40 | 35.50 | 3.40 | 57.56 | 74.00 | -16.44 | PK | Vertical |
| 7439.87 | 44.84 | 43.50 | 11.40 | 35.50 | 3.40 | 48.24 | 54.00 | -5.76 | AV | Vertical |
| 7439.67 | 54.12 | 43.50 | 11.40 | 35.50 | 3.40 | 57.52 | 74.00 | -16.48 | PK | Horizontal |
| 7439.67 | 44.78 | 43.50 | 11.40 | 35.50 | 3.40 | 48.18 | 54.00 | -5.82 | AV | Horizontal |

Note:

- 1) Scan with GFSK, $\pi/4$ -DQPSK, 8DPSK, the worst case is $\pi/4$ -DQPSK Mode.
- 2) Factor = Antenna Factor + Cable Loss – Pre-amplifier.
Emission Level = Reading + Factor
- 3) The frequency emission of peak points that did not show above the forms are at least 20dB below the limit, the frequency emission is mainly from the environment noise.



RX Mode
RSE-GFSK-H

RE_IC Test Case_RSS 1GHz-13GHz

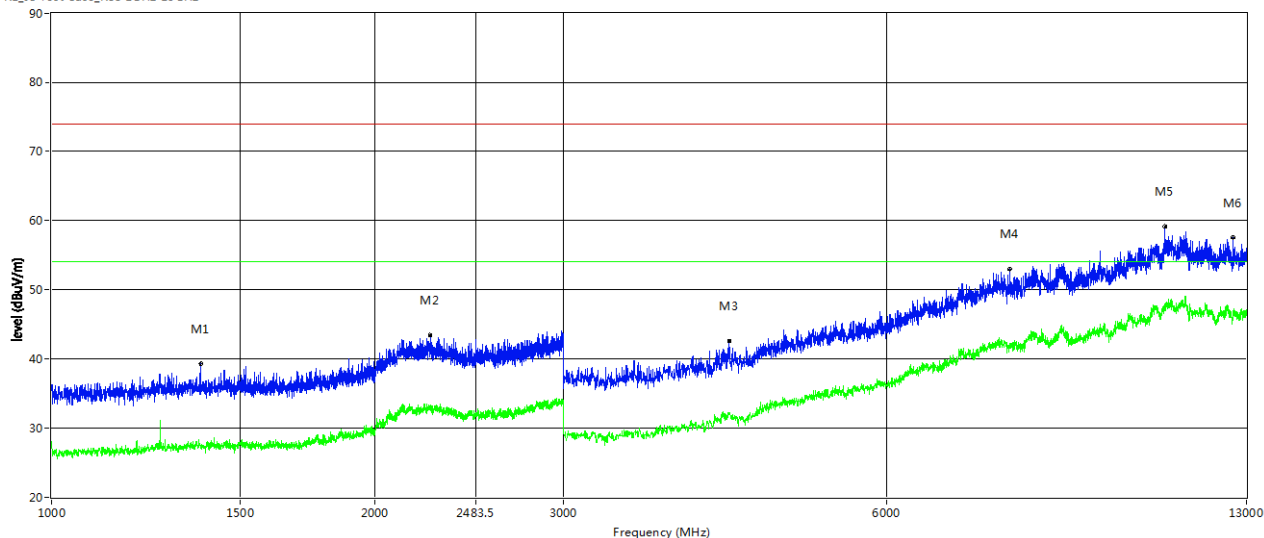

| Frequency (MHz) | Peak Level (dBuV/m) | Q-peak Level (dBuV/m) | Average Level (dBuV/m) | Factor (dB) | PK Limit (dBuV/m) | QP Limit (dBuV/m) | AV Limit (dBuV/m) | Over Limit (dB) | ANT | Verdict |
|-----------------|---------------------|-----------------------|------------------------|-------------|-------------------|-------------------|-------------------|-----------------|------------|---------|
| 1376.500 | 39.34 | -- | 27.30 | -0.72 | 74.0 | -- | 54.0 | -26.70 | Horizontal | Pass |
| 2253.500 | 43.38 | -- | 33.23 | 4.64 | 74.0 | -- | 54.0 | -20.77 | Horizontal | Pass |
| 4280.000 | 42.56 | -- | 32.24 | -8.96 | 74.0 | -- | 54.0 | -21.76 | Horizontal | Pass |
| 7810.000 | 52.94 | -- | 41.79 | 2.23 | 74.0 | -- | 54.0 | -12.21 | Horizontal | Pass |
| 10905.000 | 59.12 | -- | 47.92 | 8.61 | 74.0 | -- | 54.0 | -6.08 | Horizontal | Pass |
| 12622.500 | 57.56 | -- | 46.91 | 7.83 | 74.0 | -- | 54.0 | -7.09 | Horizontal | Pass |



RSE-GFSK-V

RE_IC Test Case_RSS 1GHz-13GHz

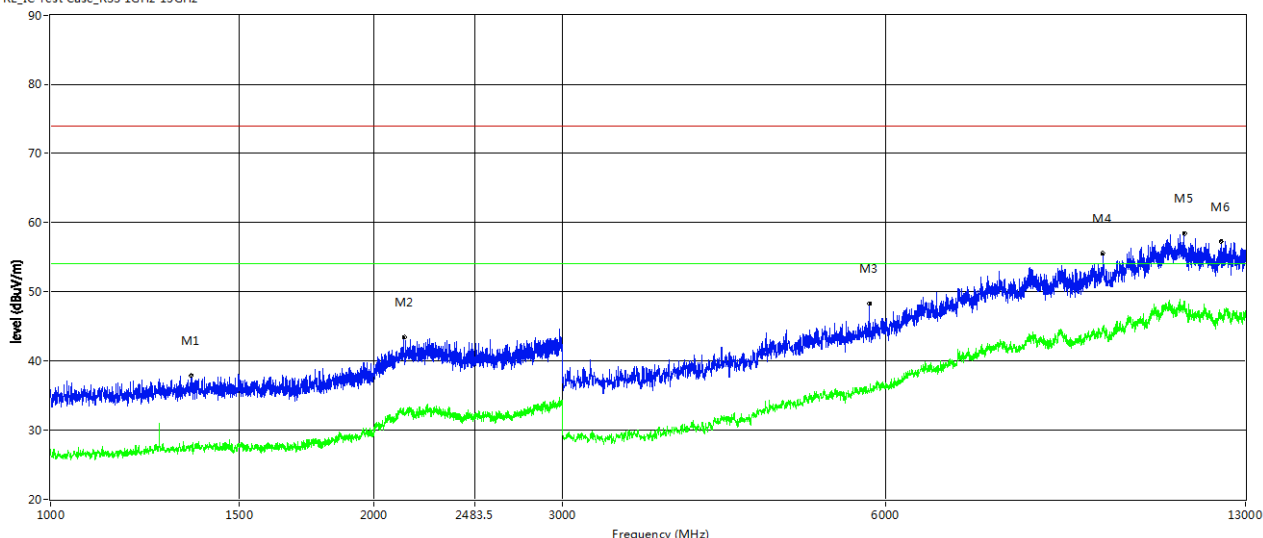

| Frequency (MHz) | Peak Level (dBuV /m) | Q-peak Level (dBuV /m) | Average Level (dBuV /m) | Factor (dB) | PK Limit (dBuV /m) | QP Limit (dBuV /m) | AV Limit (dBuV /m) | Over Limit (dB) | ANT | Verdict |
|-----------------|----------------------|------------------------|-------------------------|-------------|--------------------|--------------------|--------------------|-----------------|----------|---------|
| 1350.000 | 37.79 | -- | 27.40 | -0.79 | 74.0 | -- | 54.0 | -26.60 | Vertical | Pass |
| 2134.000 | 43.49 | -- | 32.12 | 4.36 | 74.0 | -- | 54.0 | -21.88 | Vertical | Pass |
| 5797.500 | 48.26 | -- | 35.44 | -3.87 | 74.0 | -- | 54.0 | -18.56 | Vertical | Pass |
| 9562.500 | 55.51 | -- | 44.42 | 4.51 | 74.0 | -- | 54.0 | -9.58 | Vertical | Pass |
| 11392.500 | 58.40 | -- | 48.59 | 8.48 | 74.0 | -- | 54.0 | -5.41 | Vertical | Pass |
| 12327.500 | 57.23 | -- | 46.62 | 7.78 | 74.0 | -- | 54.0 | -7.38 | Vertical | Pass |

Note: All mode has been tested, only shown the worst case in this report.



Restricted band Requirements

$\pi/4$ -DQPSK-Low
Horizontal

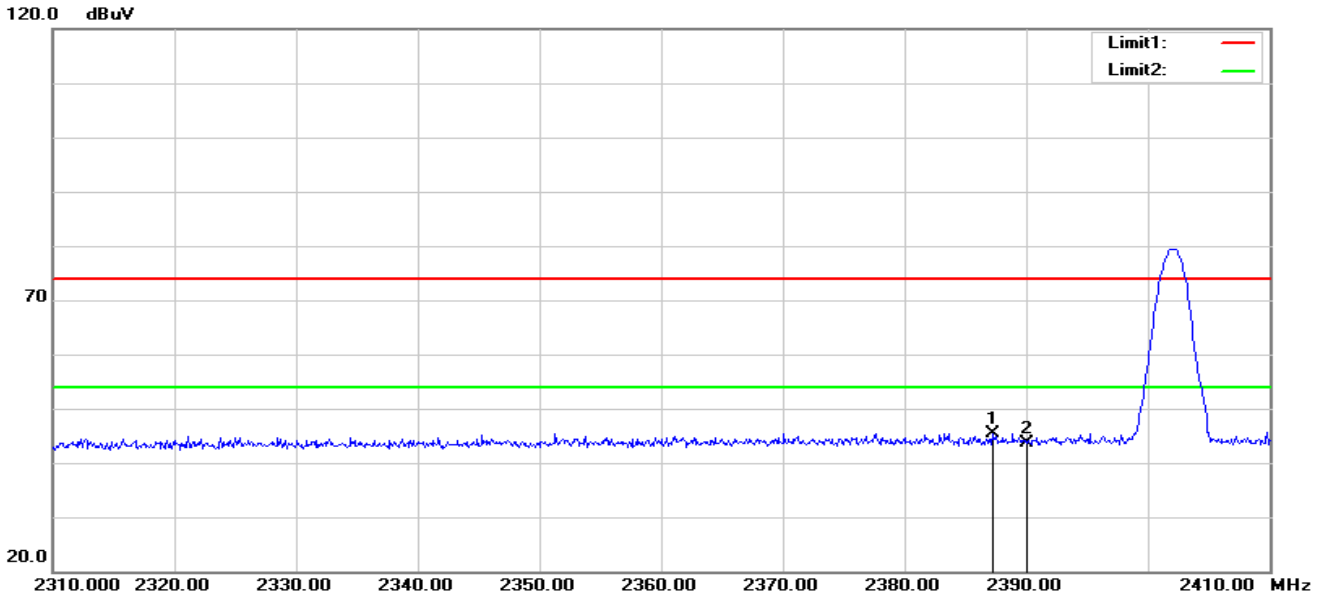

| No. | Frequency (MHz) | Reading (dBuV) | Correct Factor(dB) | Result (dBuV) | Limit (dBuV) | Margin (dB) | Remark |
|-----|-----------------|----------------|--------------------|---------------|--------------|-------------|--------|
| 1 | 2387.200 | 41.19 | 4.30 | 45.49 | 74.00 | -28.51 | peak |
| 2 | 2390.000 | 39.30 | 4.34 | 43.64 | 74.00 | -30.36 | peak |

Vertical

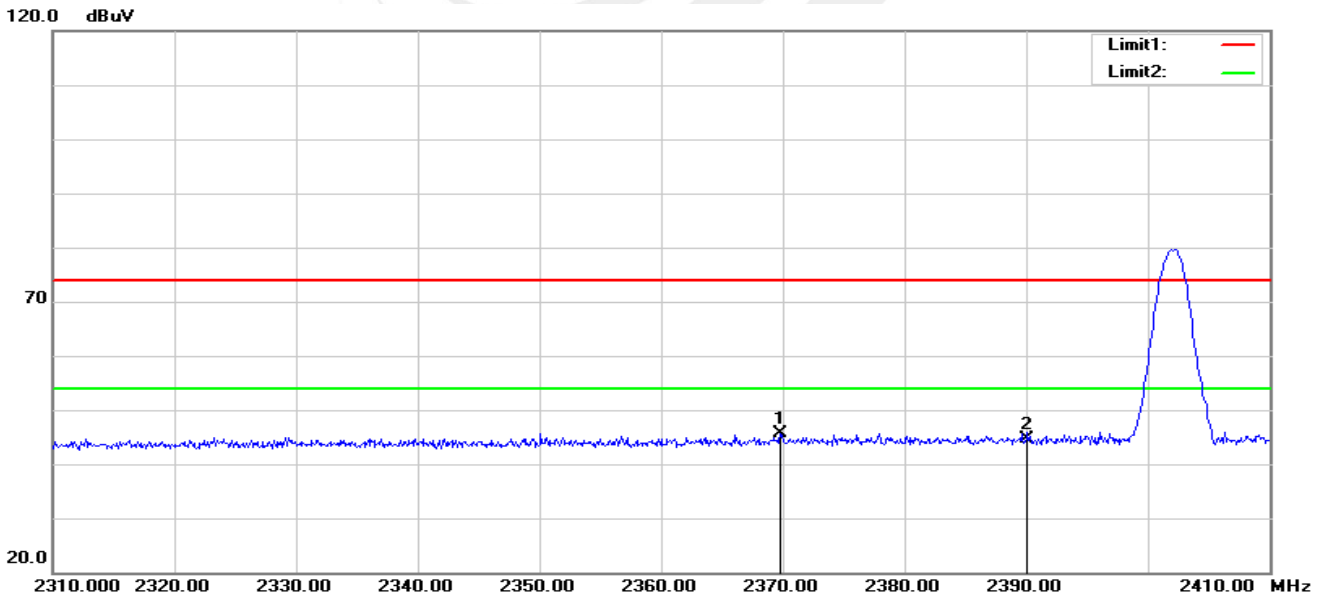

| No. | Frequency (MHz) | Reading (dBuV) | Correct Factor(dB) | Result (dBuV) | Limit (dBuV) | Margin (dB) | Remark |
|-----|-----------------|----------------|--------------------|---------------|--------------|-------------|--------|
| 1 | 2369.800 | 41.63 | 4.04 | 45.67 | 74.00 | -28.33 | peak |
| 2 | 2390.000 | 40.40 | 4.34 | 44.74 | 74.00 | -29.26 | peak |



$\pi/4$ -DQPSK-High
Horizontal

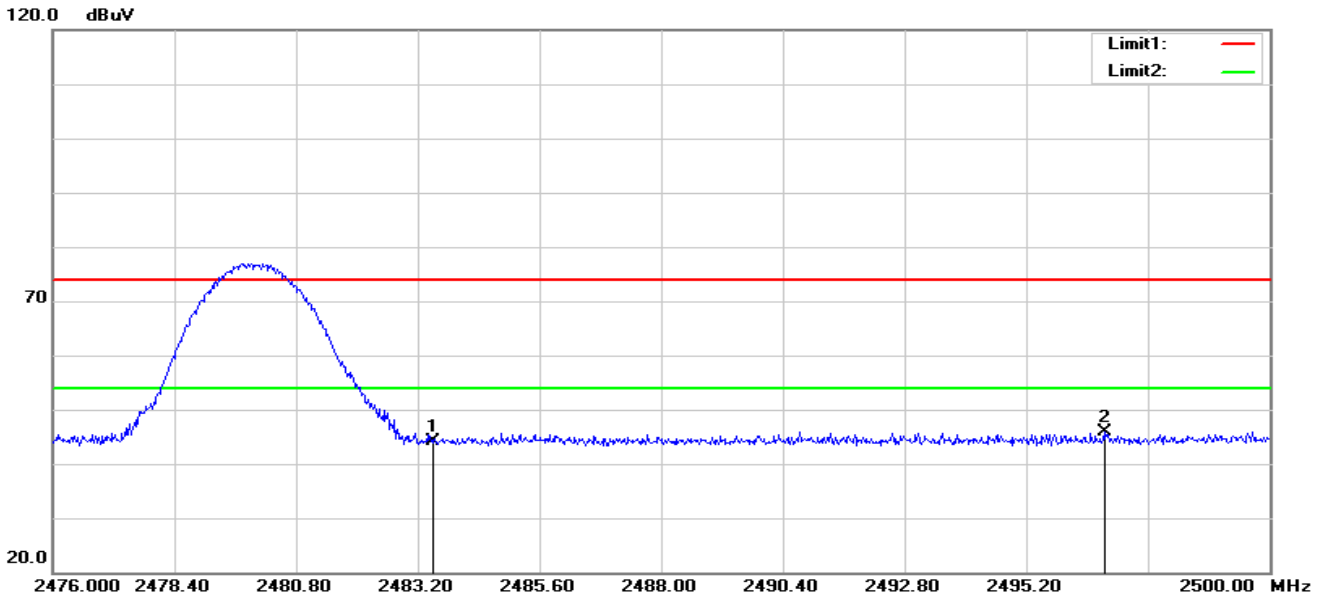

| No. | Frequency (MHz) | Reading (dBuV) | Correct Factor(dB) | Result (dBuV) | Limit (dBuV) | Margin (dB) | Remark |
|-----|-----------------|----------------|--------------------|---------------|--------------|-------------|--------|
| 1 | 2483.500 | 39.45 | 4.60 | 44.05 | 74.00 | -29.95 | peak |
| 2 | 2496.736 | 41.25 | 4.64 | 45.89 | 74.00 | -28.11 | peak |

Vertical

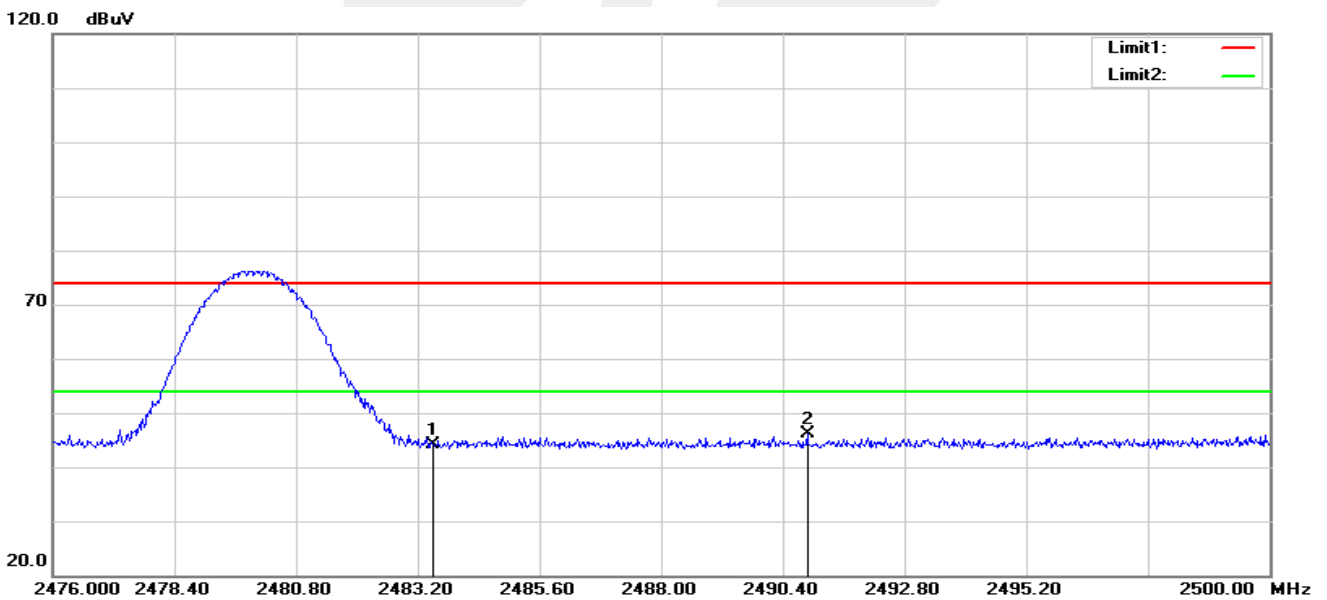

| No. | Frequency (MHz) | Reading (dBuV) | Correct Factor(dB) | Result (dBuV) | Limit (dBuV) | Margin (dB) | Remark |
|-----|-----------------|----------------|--------------------|---------------|--------------|-------------|--------|
| 1 | 2483.500 | 39.45 | 4.60 | 44.05 | 74.00 | -29.95 | peak |
| 2 | 2490.880 | 41.43 | 4.63 | 46.06 | 74.00 | -27.94 | peak |

Note: GFSK, $\pi/4$ -DQPSK, 8DPSK of the nohopping and hopping mode all have been test, the worst case is $\pi/4$ -DQPSK of the nohopping mode, this report only show the worst case.

4. CONDUCTED SPURIOUS & BAND EDGE EMISSION

4.1 LIMIT

According to FCC section 15.247(d) and RSS-247 Issue 2, February 2017 (5.5), in any 100kHz bandwidth outside the frequency band in which the spread spectrum or digitally modulated intentional radiator is operating, the radio frequency power that is produced by the intentional radiator shall be at least 20dB below that in the 100kHz bandwidth within the band that contains the highest level of the desired power, based on either an RF conducted or a radiated measurement.

4.2 TEST PROCEDURE

| Spectrum Parameter | Setting |
|---------------------------------------|---------------------------------|
| Detector | Peak |
| Start/Stop Frequency | 30 MHz to 10th carrier harmonic |
| RB / VB (emission in restricted band) | 100 KHz/300 KHz |
| Trace-Mode: | Max hold |

For Band edge

| Spectrum Parameter | Setting |
|---------------------------------------|---|
| Detector | Peak |
| Start/Stop Frequency | Lower Band Edge: 2300– 2403 MHz Upper Band Edge: 2476 – 2500 MHz |
| RB / VB (emission in restricted band) | 100 KHz/300 KHz |
| Trace-Mode: | Max hold |

Remark: Hopping on and Hopping off mode all have been tested, only worst case hopping off is reported.

4.3 TEST SETUP

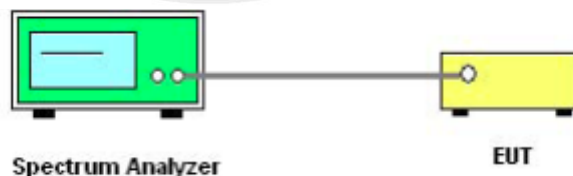

The EUT is connected to the Spectrum Analyzer; the RF load attached to the EUT antenna terminal is 50Ohm; the path loss as the factor is calibrated to correct the reading. Make the measurement with the spectrum analyzer's resolution bandwidth (RBW) = 100 kHz. In order to make an accurate measurement, set the span greater than RBW.

4.4 EUT OPERATION CONDITIONS

The EUT tested system was configured as the statements of 2.3 Unless otherwise a special operating condition is specified in the follows during the testing.



4.5 TEST RESULTS

| | | | |
|--------------|-------------------------|--------------------|----------------------|
| Temperature: | 25°C | Relative Humidity: | 50% |
| Test Mode: | GFSK(1Mbps)-00/39/78 CH | Test Voltage: | DC 7.4V from battery |

00 CH

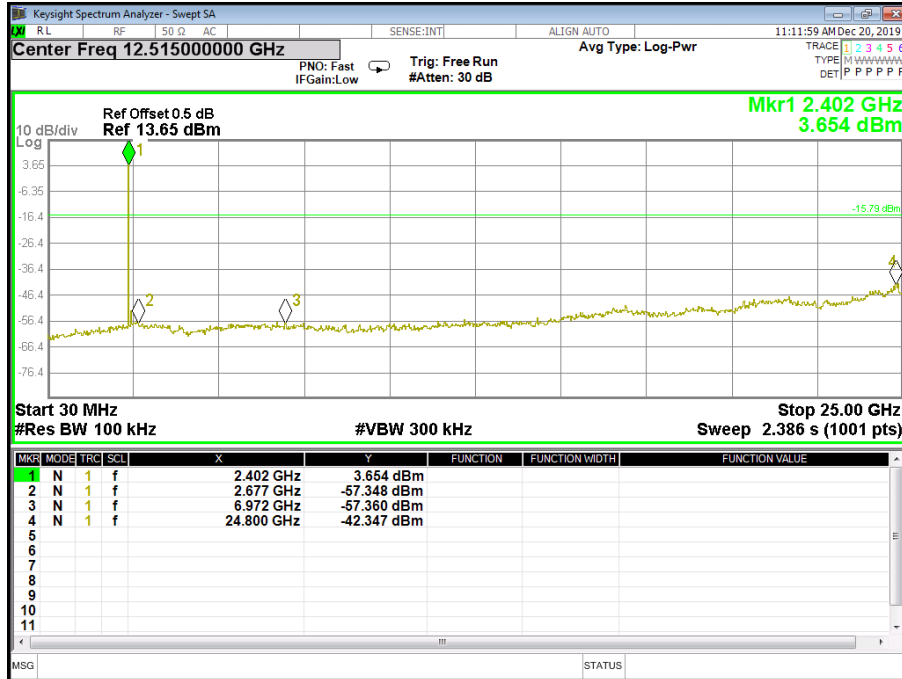

39 CH

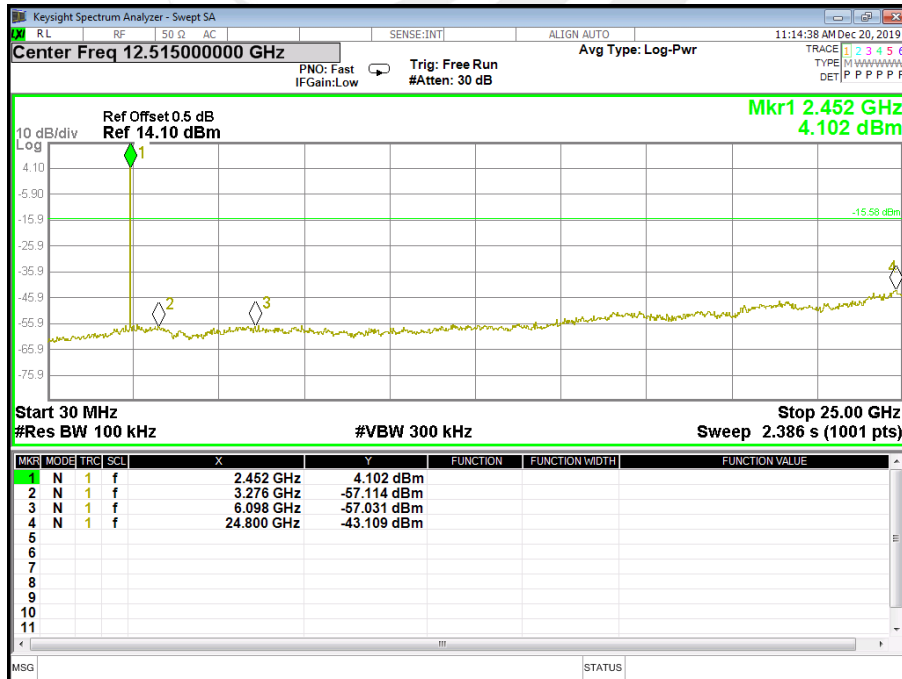



78 CH

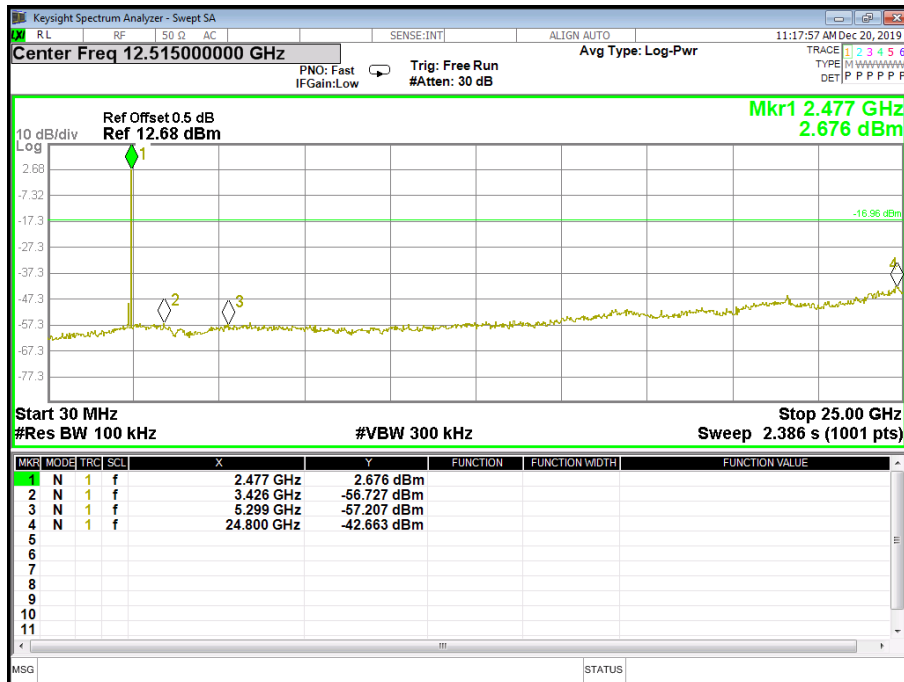



For Band edge(it's also the reference level for conducted spurious emission)

00 CH

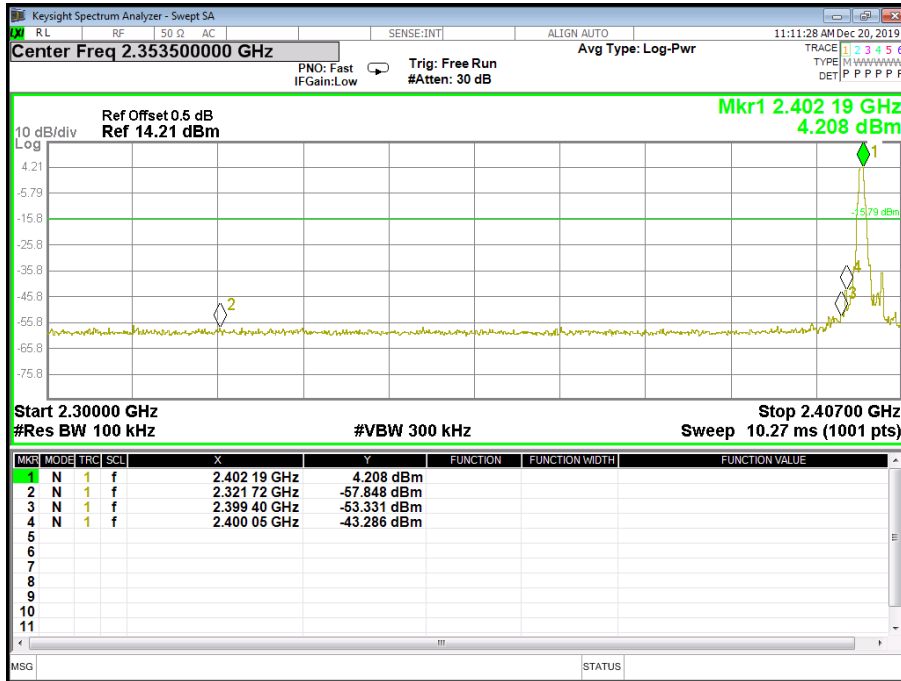

39 CH

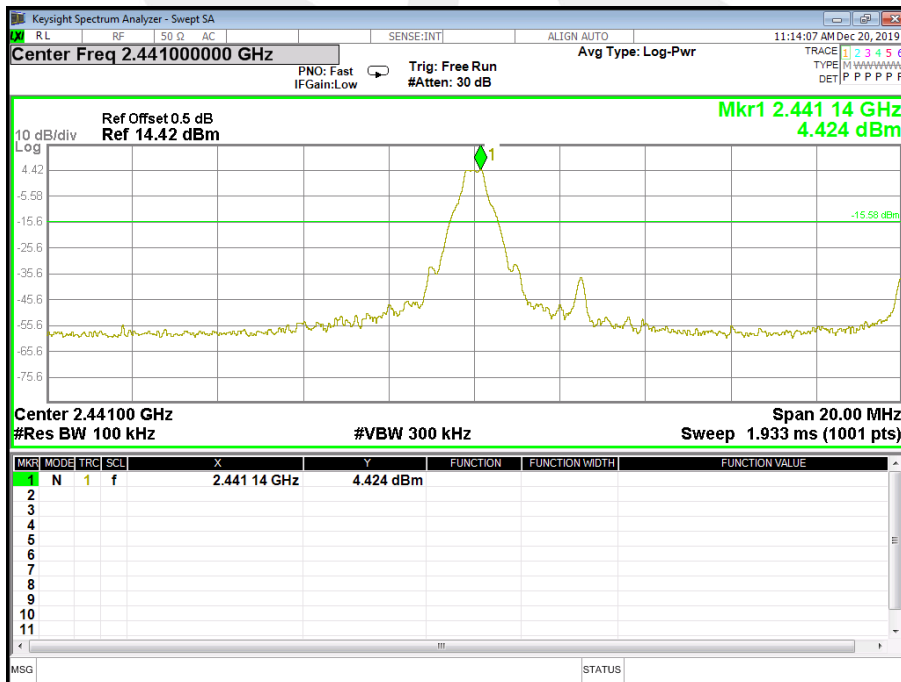



78 CH

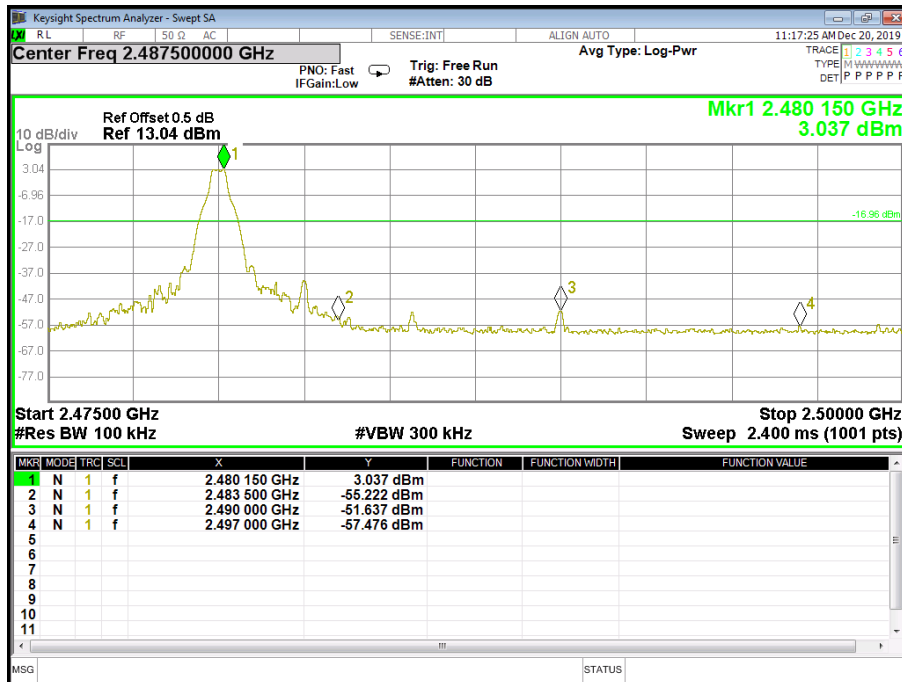



For Hopping Band edge

00 CH

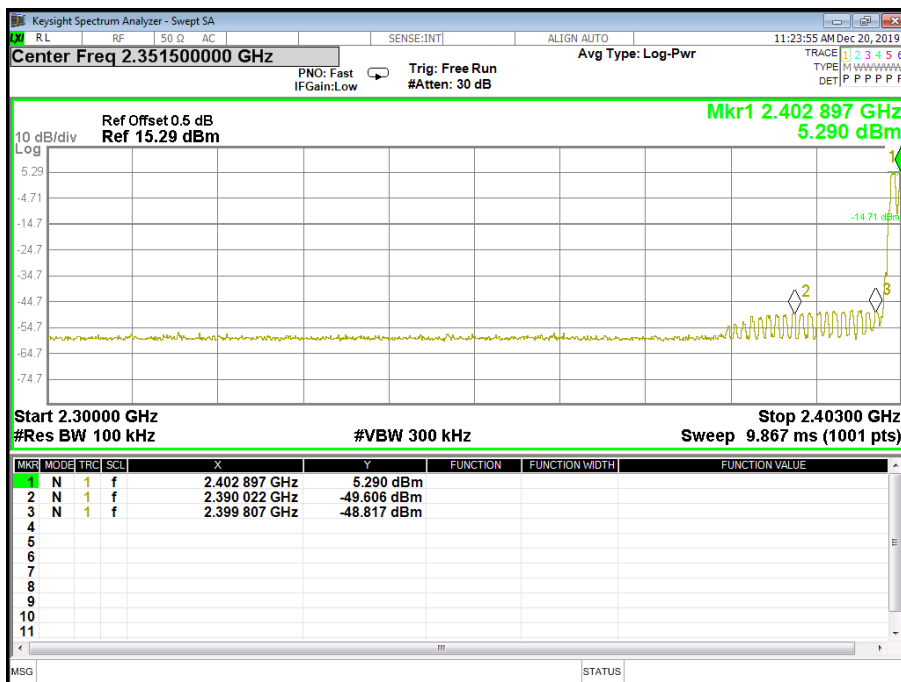

78 CH

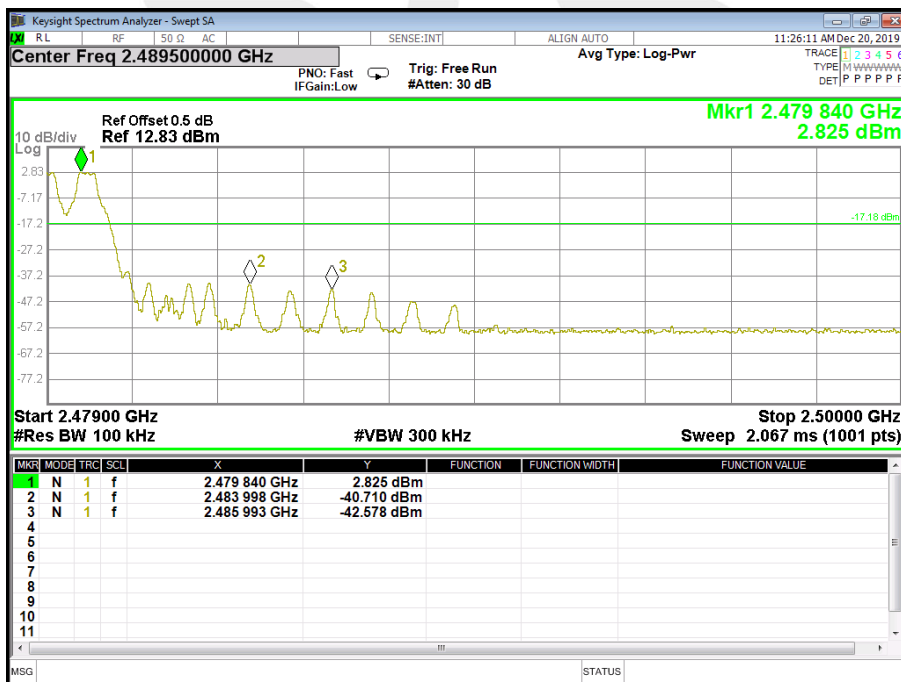



| | | | |
|--------------|---------------------------------------|--------------------|----------------------|
| Temperature: | 25°C | Relative Humidity: | 50% |
| Test Mode: | $\pi/4$ -DQPSK(2Mbps)- 00/39/78 CH | Test Voltage: | DC 7.4V from battery |

00 CH

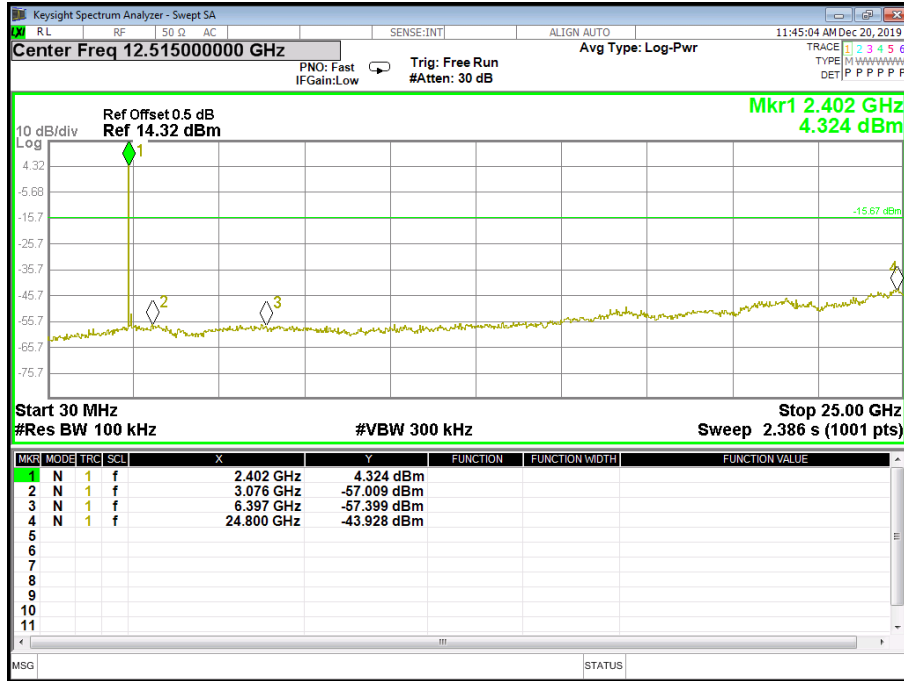

39 CH

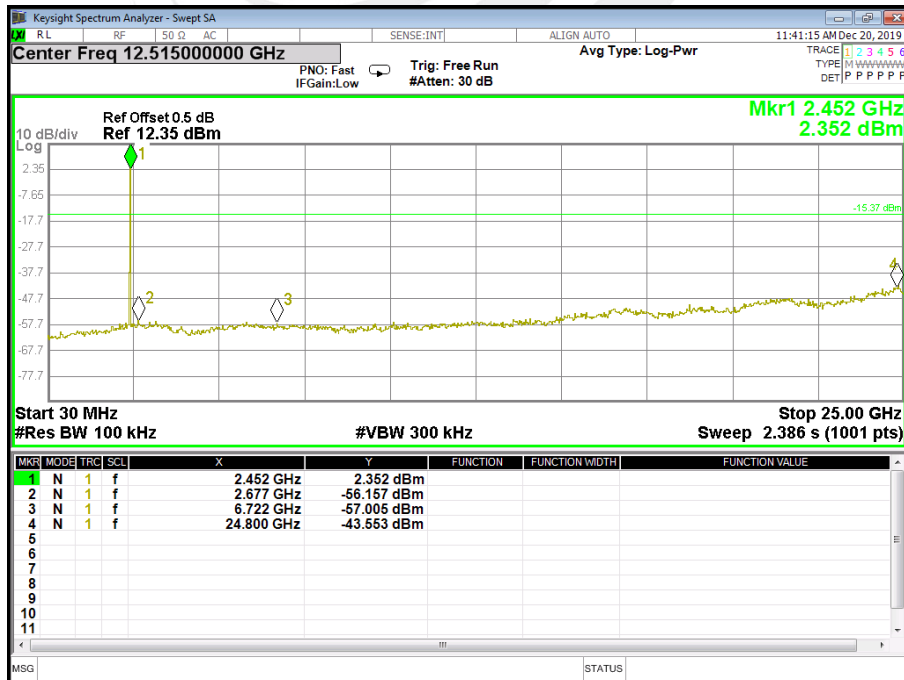



78 CH

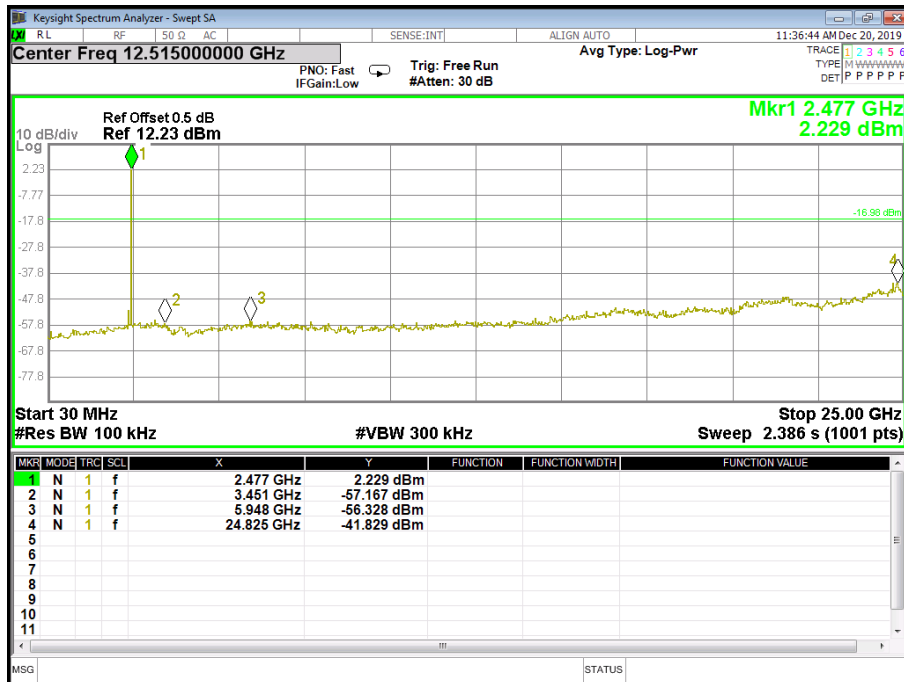



For Band edge(it's also the reference level for conducted spurious emission)

00 CH

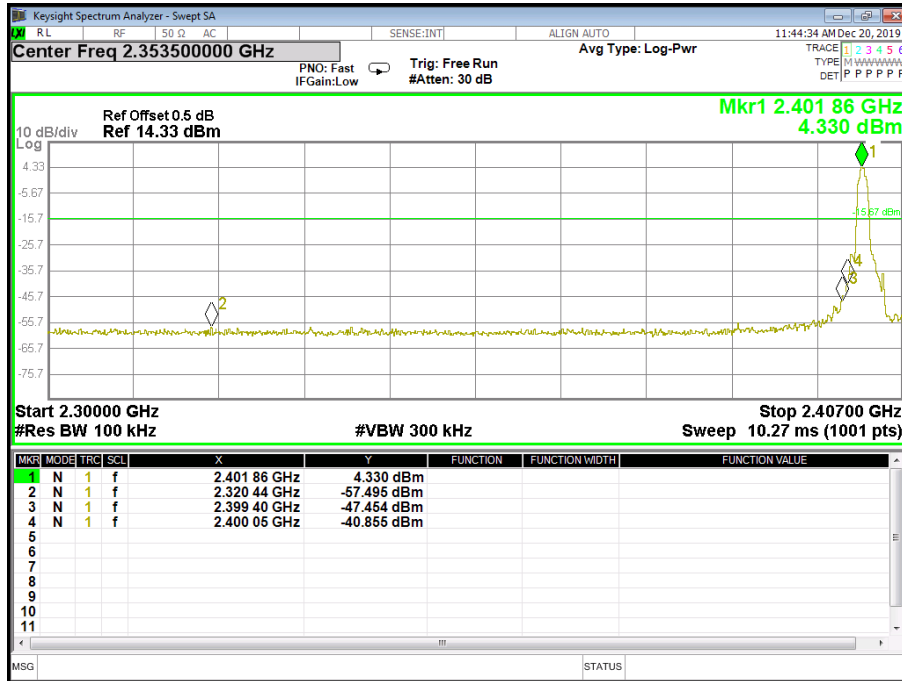

39 CH

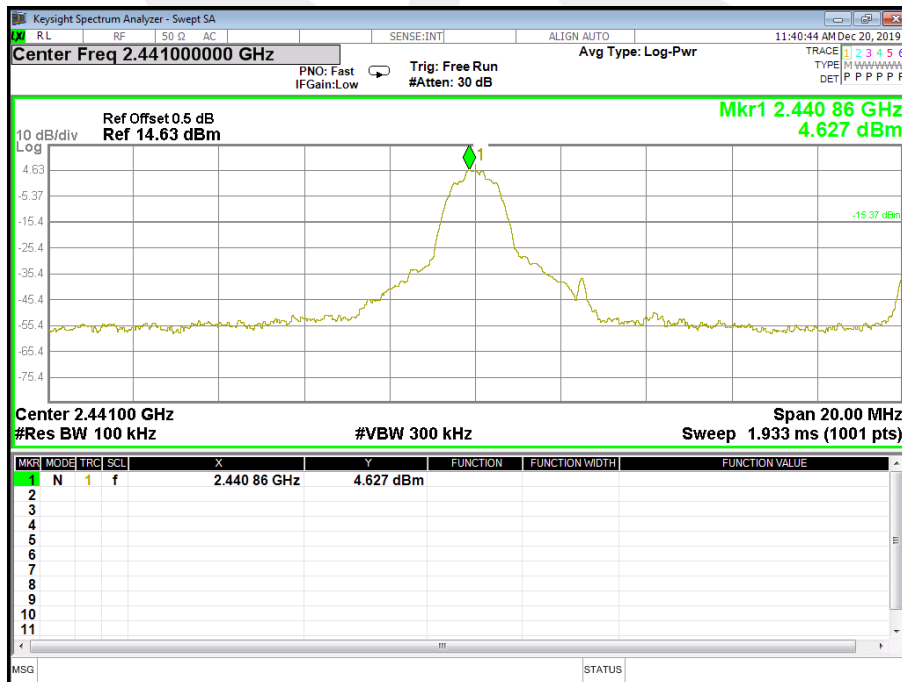



78 CH

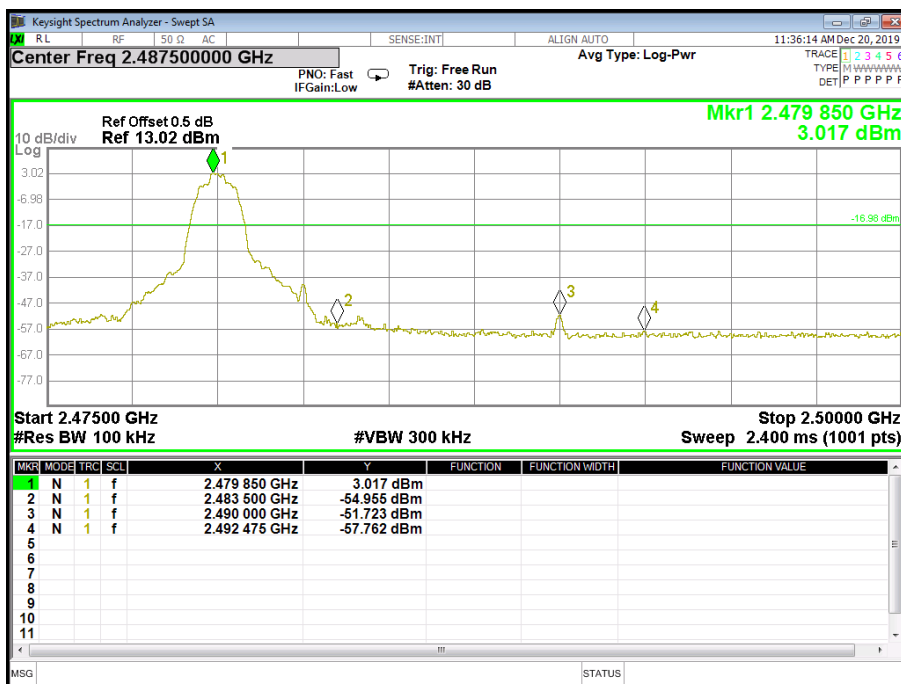



For Hopping Band edge

00 CH

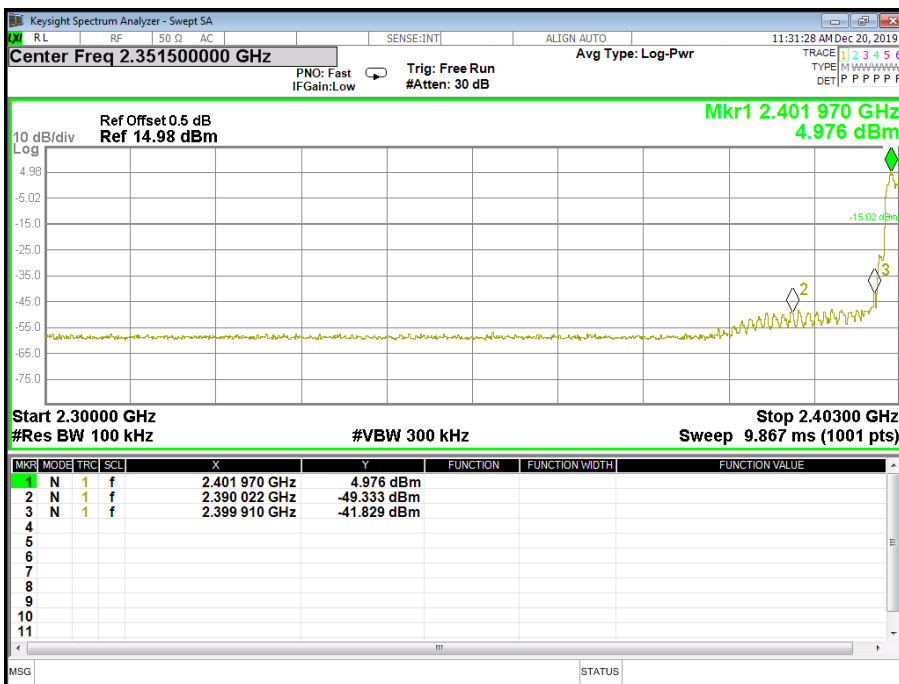

78 CH

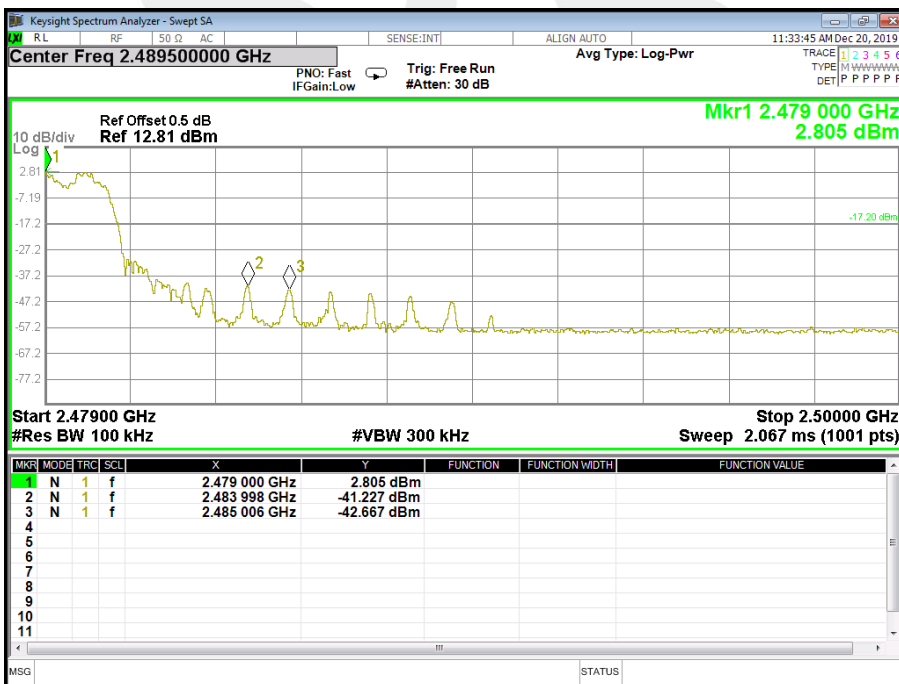



| | | | |
|--------------|---------------------------|--------------------|----------------------|
| Temperature: | 25°C | Relative Humidity: | 50% |
| Test Mode: | 8DPSK(3Mbps) -00/39/78 CH | Test Voltage: | DC 7.4V from battery |

00 CH

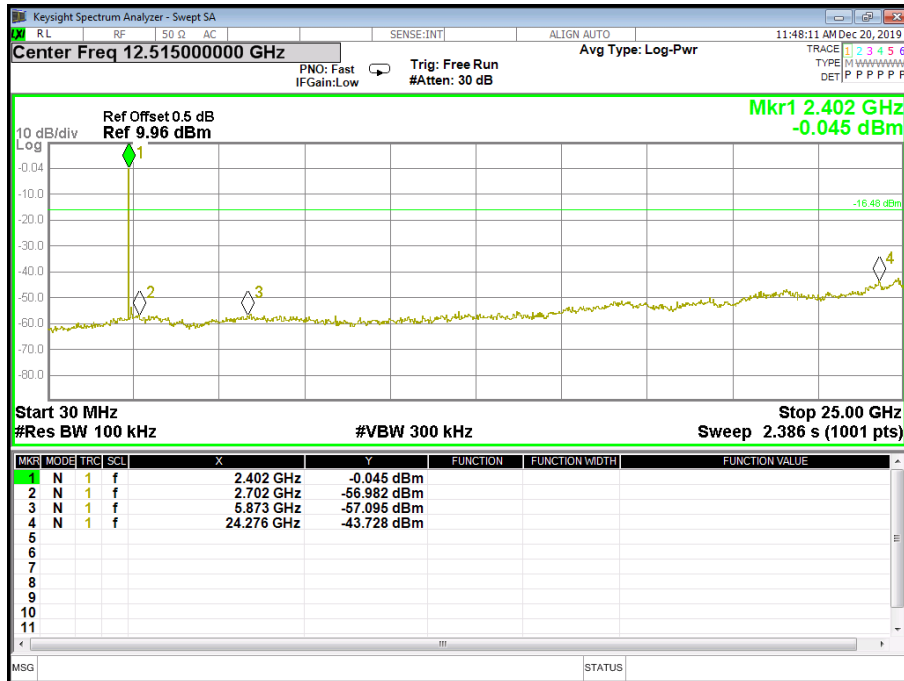

39 CH

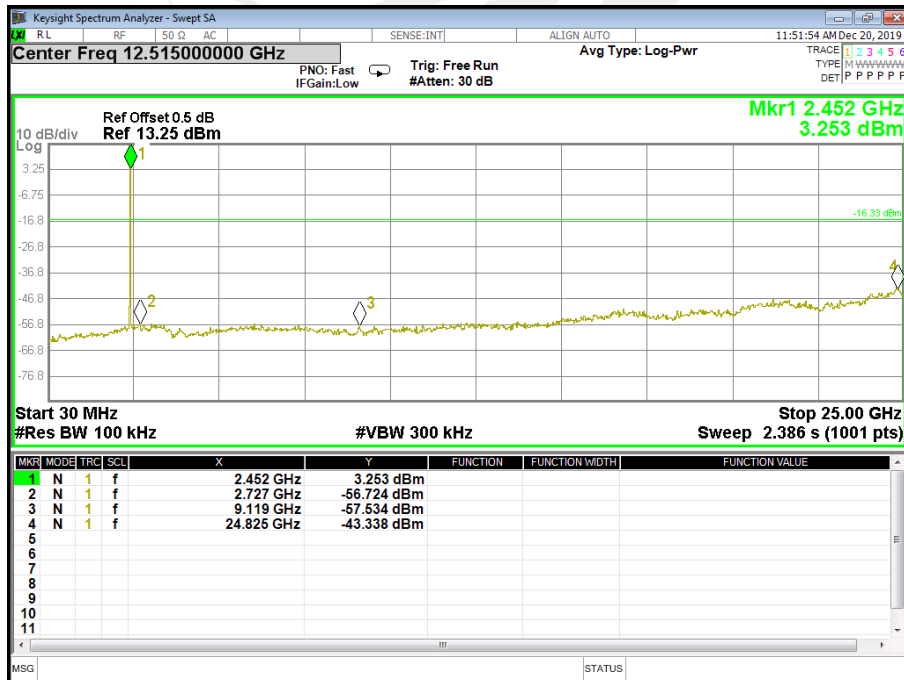



78 CH

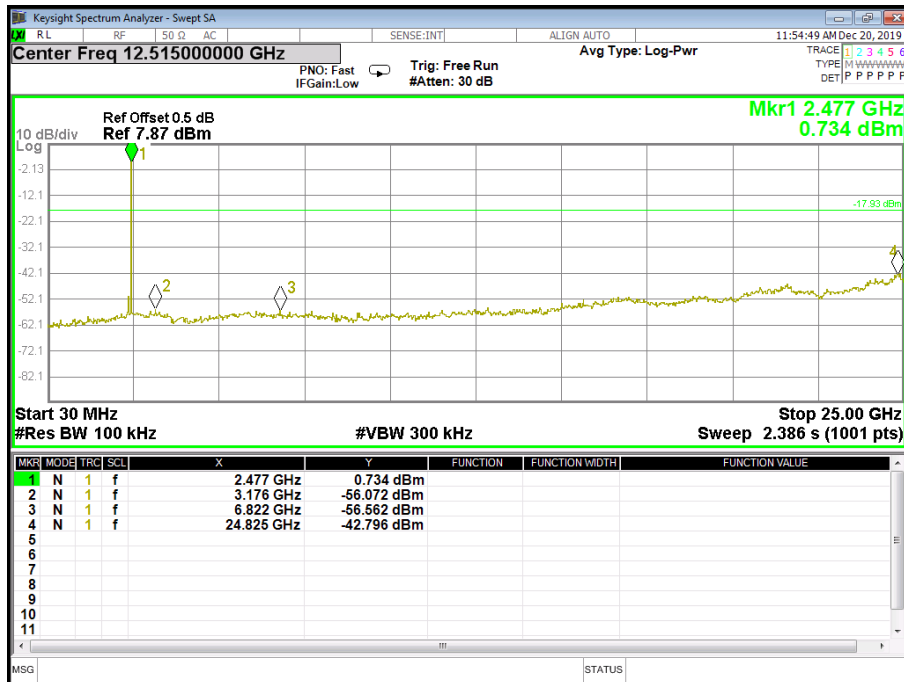



For Band edge(it's also the reference level for conducted spurious emission)

00 CH

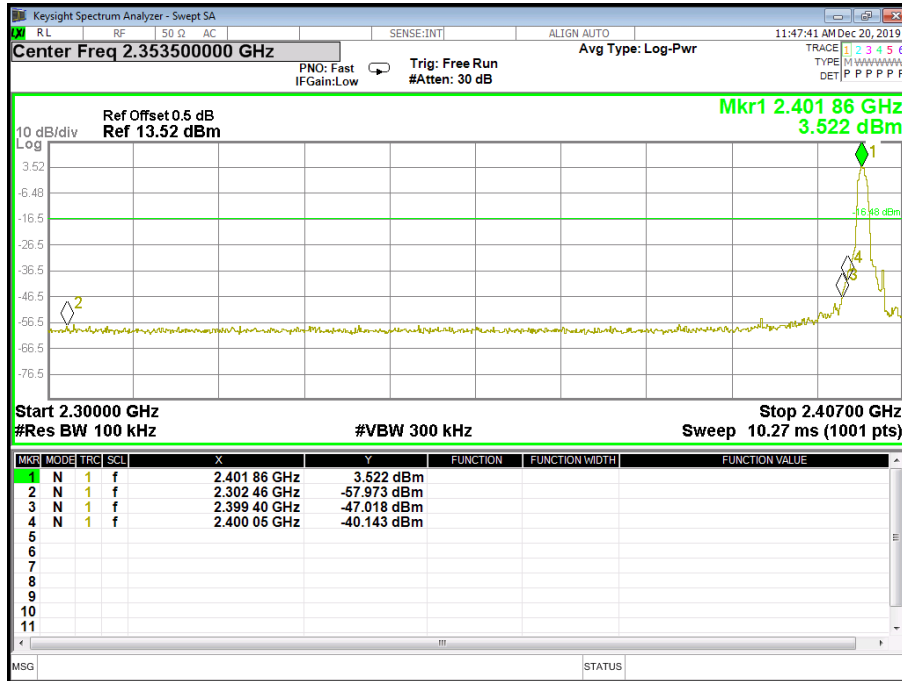

39 CH

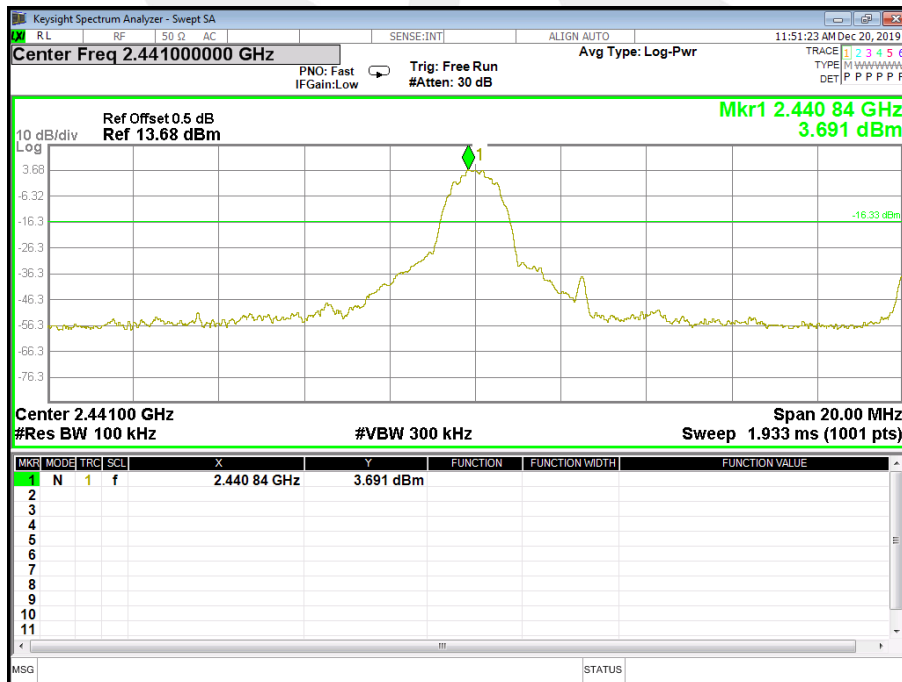



78 CH

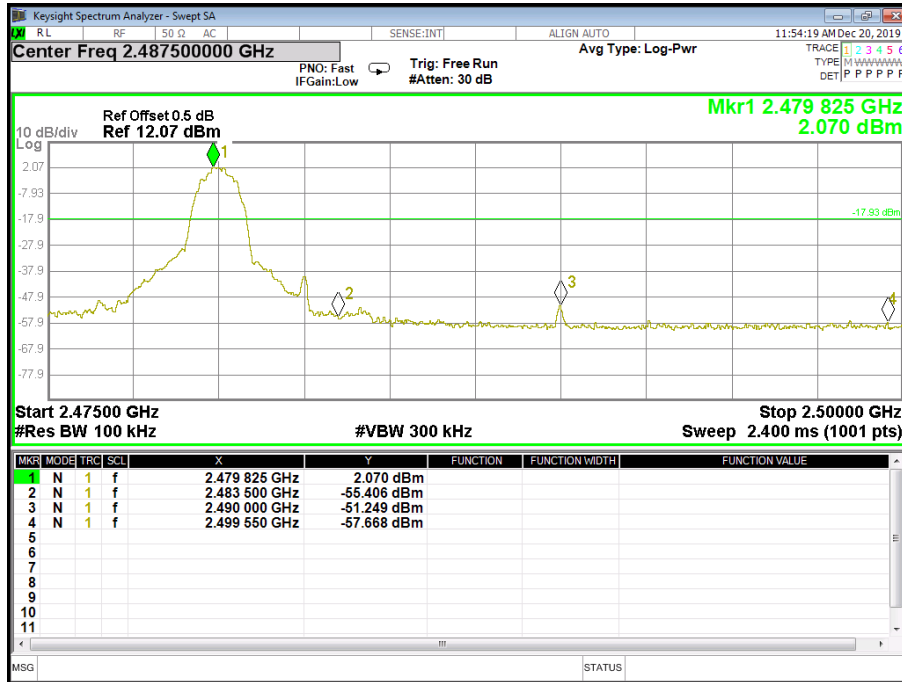



For Hopping Band edge

00 CH

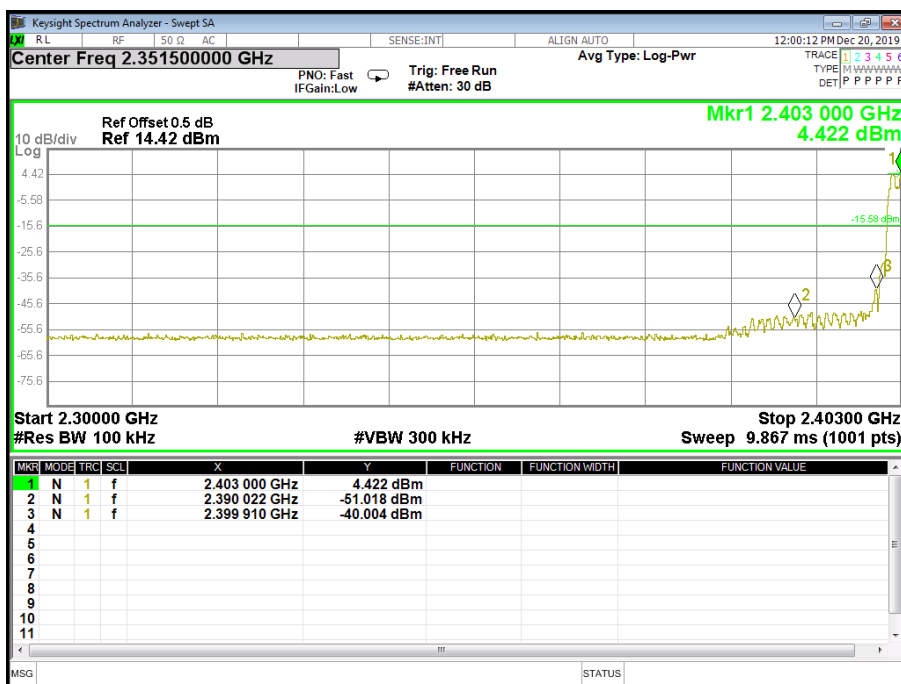

78 CH

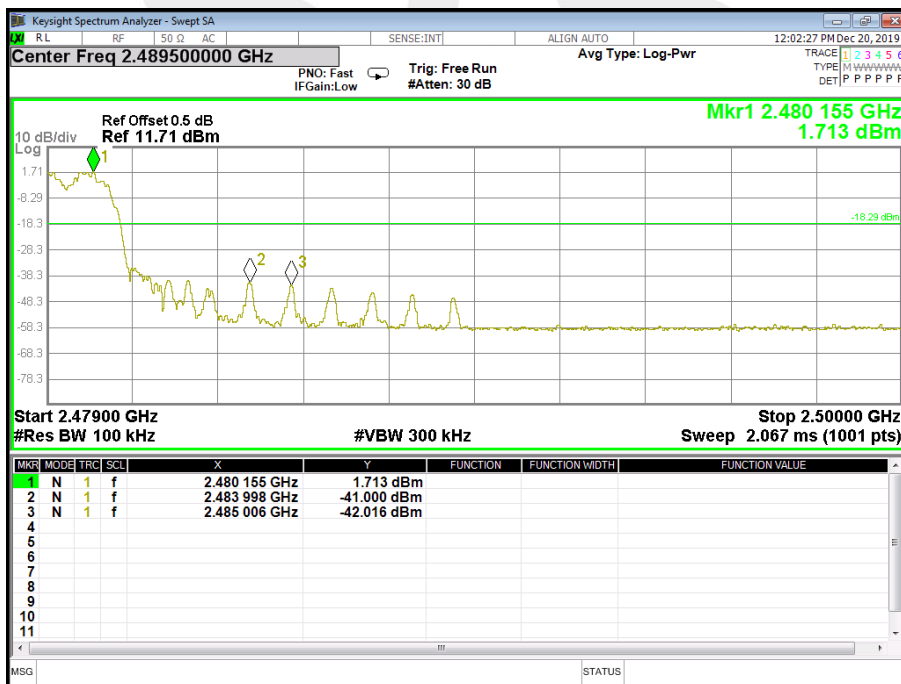



5. NUMBER OF HOPPING CHANNEL

5.1 LIMIT

| FCC Part 15.247, Subpart C RSS-247 Issue 2 | | | | |
|---|------------------------------|-------|-------------------------|--------|
| Section | Test Item | Limit | FrequencyRange (MHz) | Result |
| 15.247 (a)(1)(iii) RSS-247 | Number of Hopping Channel | ≥15 | 2400-2483.5 | PASS |

| Spectrum Parameters | Setting |
|---------------------|----------------------------|
| Attenuation | Auto |
| Span Frequency | > Operating FrequencyRange |
| RB | 300KHz |
| VB | 300KHz |
| Detector | Peak |
| Trace | Max Hold |
| Sweep Time | Auto |

5.2 TEST PROCEDURE

- The EUT was directly connected to the spectrum analyzer and antenna output port as show in the block diagram below.
- Spectrum Setting: RBW= 300KHz, VBW=300KHz, Sweep time = Auto.

5.3 TEST SETUP



5.4 EUT OPERATION CONDITIONS

The EUT tested system was configured as the statements of 2.4 Unless otherwise a special operating condition is specified in the follows during the testing.



5.5 TEST RESULTS

| | | | |
|--------------|-------------------------|--------------------|----------------------|
| Temperature: | 25°C | Relative Humidity: | 60% |
| Test Mode: | Hopping Mode -GFSK Mode | Test Voltage: | DC 7.4V from battery |

Number of Hopping Channel

79

Hopping channel

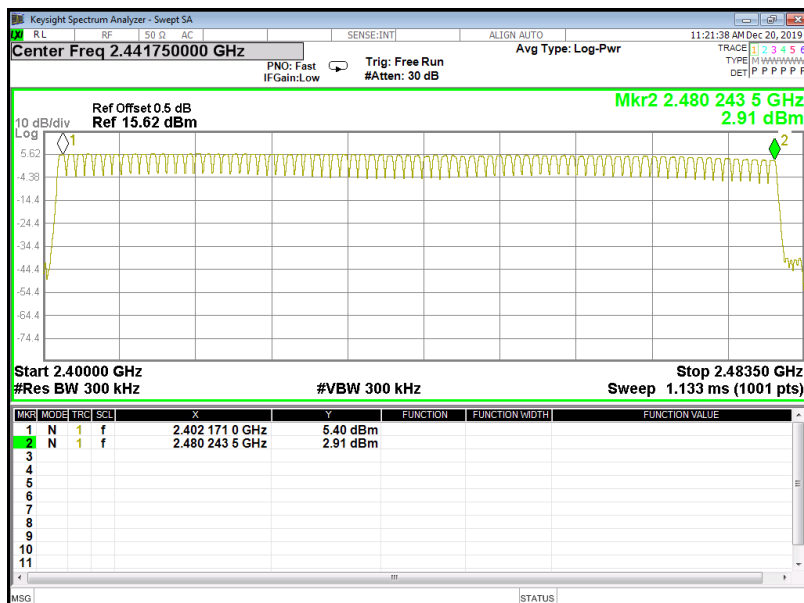



6. AVERAGE TIME OF OCCUPANCY

6.1 LIMIT

| FCC Part 15.247, Subpart C RSS-247 Issue 2 | | | | |
|---|---------------------------|--------|-----------------------|--------|
| Section | Test Item | Limit | Frequency Range (MHz) | Result |
| 15.247 (a)(1)(iii) RSS-247 | Average Time of Occupancy | 0.4sec | 2400-2483.5 | PASS |

6.2 TEST PROCEDURE

- a. The transmitter output (antenna port) was connected to the spectrum analyzer.
- b. Set RBW = 1MHz/VBW = 3MHz.
- c. Use a video trigger with the trigger level set to enable triggering only on full pulses.
- d. Sweep Time is more than once pulse time.
- e. Set the center frequency on any frequency would be measure and set the frequency span to zero span.
- f. Measure the maximum time duration of one single pulse.
- g. Set the EUT for DH5, DH3 and DH1 packet transmitting.
- h. Measure the maximum time duration of one single pulse.
- i. DH5 Packet permit maximum $1600 / 79 / 6 = 3.37$ hops per second in each channel (5 time slots RX, 1 time slot TX). So the dwell time is the time duration of the pulse times $3.37 \times 31.6 = 106.6$ within 31.6 seconds.
- j. DH3 Packet permit maximum $1600 / 79 / 4 = 5.06$ hops per second in each channel (3 time slots RX, 1 time slot TX). So the dwell time is the time duration of the pulse times $5.06 \times 31.6 = 160$ within 31.6 seconds.
- k. DH1 Packet permit maximum $1600 / 79 / 2 = 10.12$ hops per second in each channel (1 time slot RX, 1 time slot TX). So the dwell time is the time duration of the pulse times $10.12 \times 31.6 = 320$ within 31.6 seconds.

6.3 TEST SETUP



6.4 EUT OPERATION CONDITIONS

The EUT tested system was configured as the statements of 2.4 Unless otherwise a special operating condition is specified in the follows during the testing.



6.5 TEST RESULTS

| | | | |
|--------------|-------------------------|--------------------|----------------------|
| Temperature: | 25°C | Relative Humidity: | 50% |
| Test Mode: | GFSK(1Mbps)-DH1/DH3/DH5 | Test Voltage: | DC 7.4V from battery |

| Data Packet | Channel | pulse time(ms) | Dwell Time(s) | Limits(s) |
|-------------|---------|----------------|---------------|-----------|
| DH1 | middle | 0.382 | 0.122 | 0.4 |
| DH3 | middle | 1.644 | 0.263 | 0.4 |
| DH5 | middle | 2.888 | 0.308 | 0.4 |





CH39-DH1



CH39-DH3

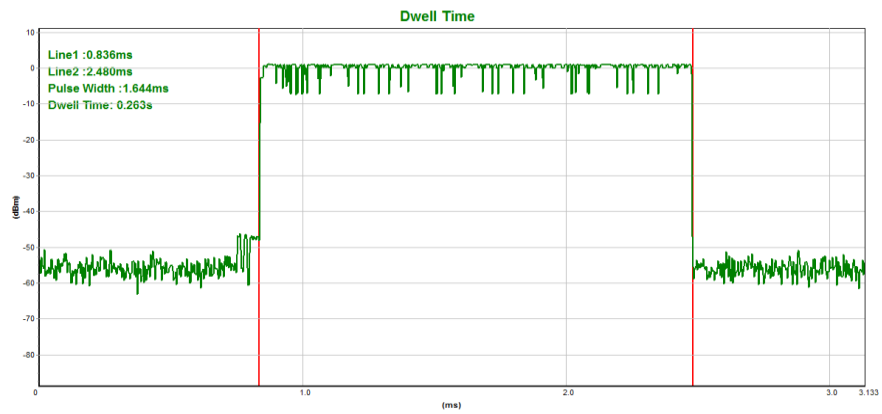

CH39-DH5

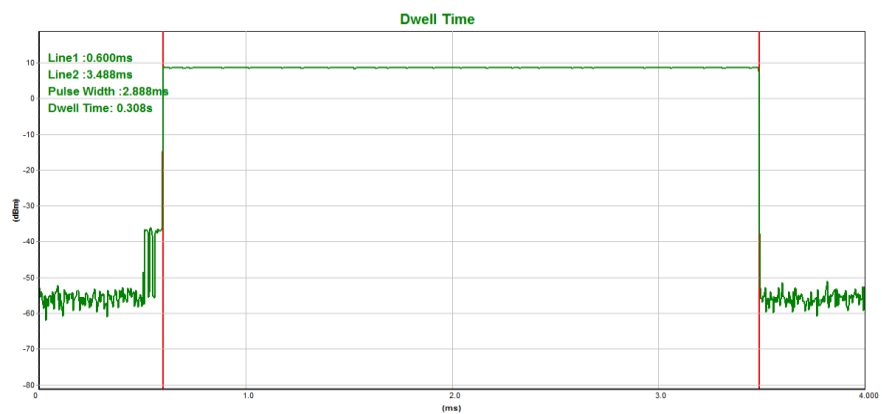



| | | | |
|--------------|--|--------------------|----------------------|
| Temperature: | 25°C | Relative Humidity: | 50% |
| Test Mode: | $\pi/4$ -DQPSK(2Mbps)- 2DH1/2DH3/2DH5 | Test Voltage: | DC 7.4V from battery |

| Data Packet | Channel | pulse time(ms) | Dwell Time(s) | Limits(s) |
|-------------|---------|----------------|---------------|-----------|
| 2DH1 | middle | 0.391 | 0.125 | 0.4 |
| 2DH3 | middle | 1.646 | 0.263 | 0.4 |
| 2DH5 | middle | 2.898 | 0.309 | 0.4 |





CH39-2DH1



CH39-2DH3

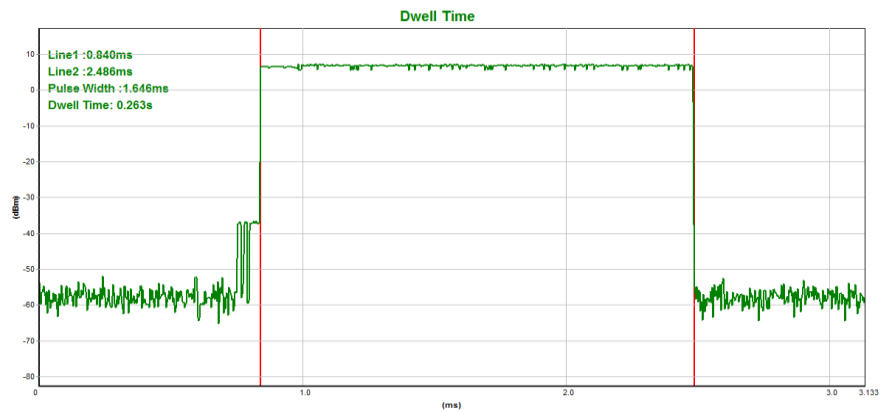

CH39-2DH5

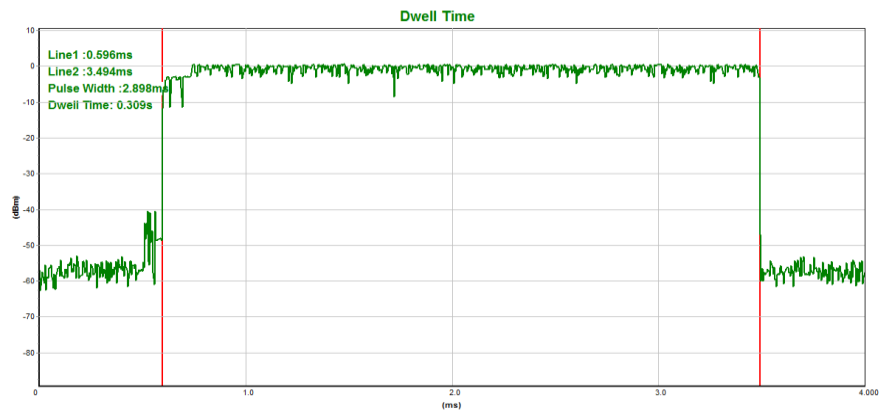



| | | | |
|--------------|---------------------------------|--------------------|----------------------|
| Temperature: | 25°C | Relative Humidity: | 50% |
| Test Mode: | 8DPSK(3Mbps)- 3DH1/3DH3/3DH5 | Test Voltage: | DC 7.4V from battery |

| Data Packet | Channel | pulse time(ms) | Dwell Time(s) | Limits(s) |
|-------------|---------|----------------|---------------|-----------|
| 3DH1 | middle | 0.393 | 0.126 | 0.4 |
| 3DH3 | middle | 1.650 | 0.264 | 0.4 |
| 3DH5 | middle | 2.898 | 0.309 | 0.4 |





CH39-3DH1



CH39-3DH3



CH39-3DH5

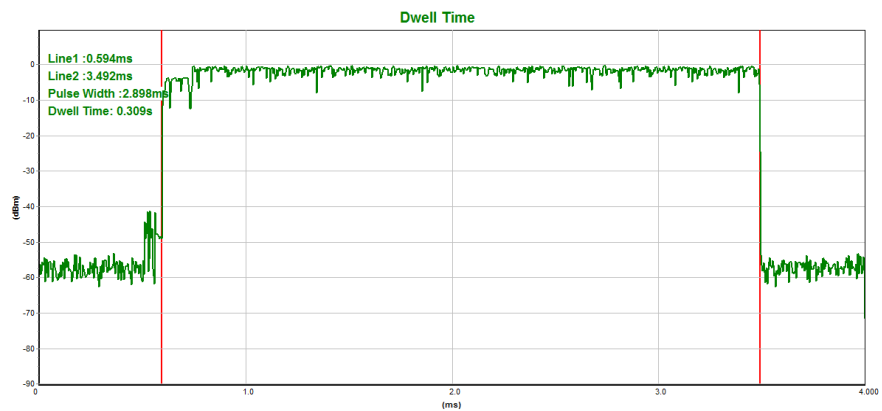

7. HOPPING CHANNEL SEPARATION MEASUREMENT

7.1 LIMIT

Frequency hopping systems shall have hopping channel carrier frequencies separated by a minimum of 25 kHz or the 20 dB bandwidth of the hopping channel, whichever is greater. Alternatively, frequency hopping systems operating in the 2400-2483.5 MHz band may have hopping channel carrier frequencies that are separated by 25 kHz or two-thirds of the 20 dB bandwidth of the hopping channel, whichever is greater, provided the systems operate with an output power no greater than 125 mW.

| Spectrum Parameter | Setting |
|--------------------|---|
| Attenuation | Auto |
| Span Frequency | > 20 dB Bandwidth or Channel Separation |
| RB | 30 kHz (20dB Bandwidth) / 30 kHz (Channel Separation) |
| VB | 100 kHz (20dB Bandwidth) / 100 kHz (Channel Separation) |
| Detector | Peak |
| Trace | Max Hold |
| Sweep Time | Auto |

7.2 TEST PROCEDURE

- The transmitter output (antenna port) was connected to the spectrum analyser in peak hold mode.
- The resolution bandwidth of 30 kHz and the video bandwidth of 100 kHz were utilised for 20 dB bandwidth measurement.
- The resolution bandwidth of 30 kHz and the video bandwidth of 100 kHz were utilised for channel separation measurement.

7.3 TEST SETUP

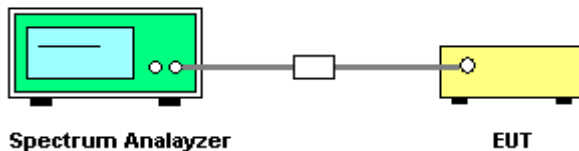

7.4 EUT OPERATION CONDITIONS

The EUT was programmed to be in continuously transmitting mode.



7.5 TEST RESULTS

| | | | |
|--------------|--|--------------------|----------------------|
| Temperature: | 25°C | Relative Humidity: | 50% |
| Test Mode: | CH00 / CH39 / CH78 (GFSK(1Mbps) Mode) | Test Voltage: | DC 7.4V from battery |

| Frequency | Mark1 Frequency (MHz) | Mark2 Frequency (MHz) | Ch. Separation (MHz) | Limit (MHz) | Result |
|-----------|-----------------------|-----------------------|----------------------|-------------|----------|
| 2402 MHz | 2401.981 | 2402.983 | 1.002 | 0.946 | Complies |
| 2441 MHz | 2440.978 | 2441.977 | 0.999 | 0.946 | Complies |
| 2480 MHz | 2478.882 | 2479.980 | 1.098 | 0.943 | Complies |

For GFSK: Ch. Separation Limits: > 20dB bandwidth

CH00 -1Mbps

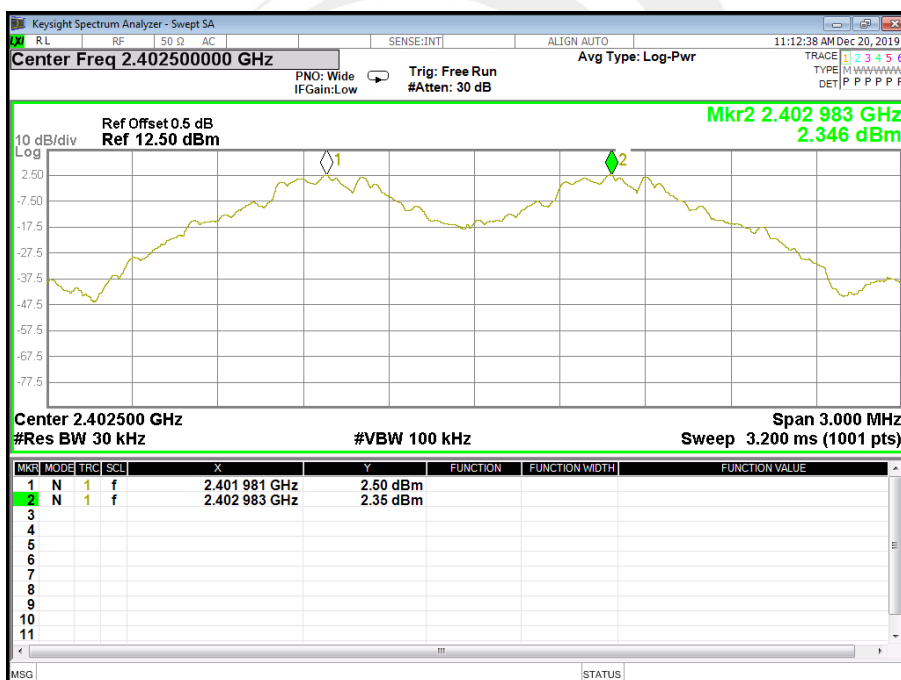



CH39 -1Mbps

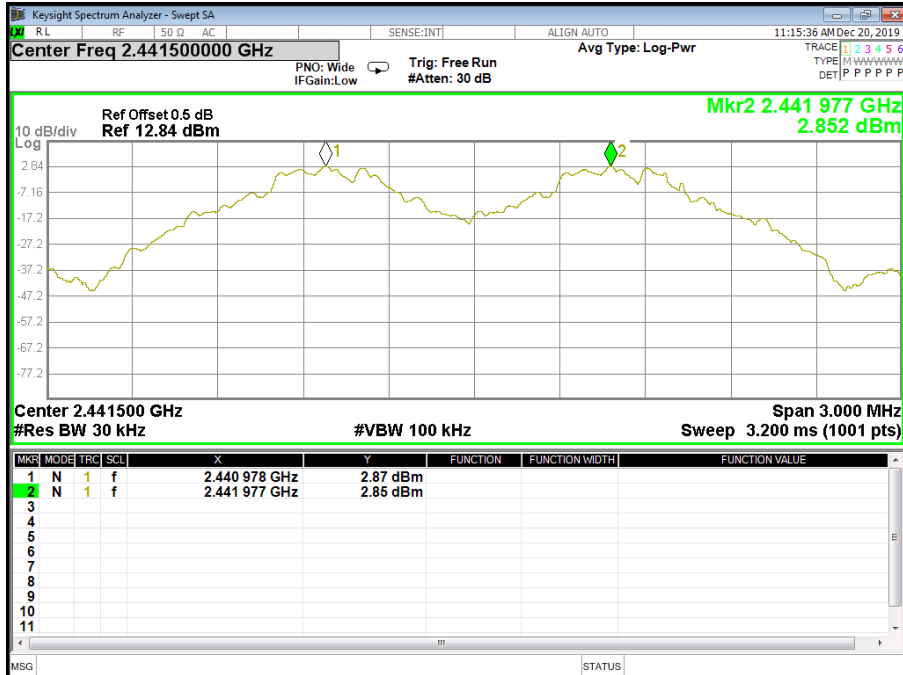

CH78 -1Mbps

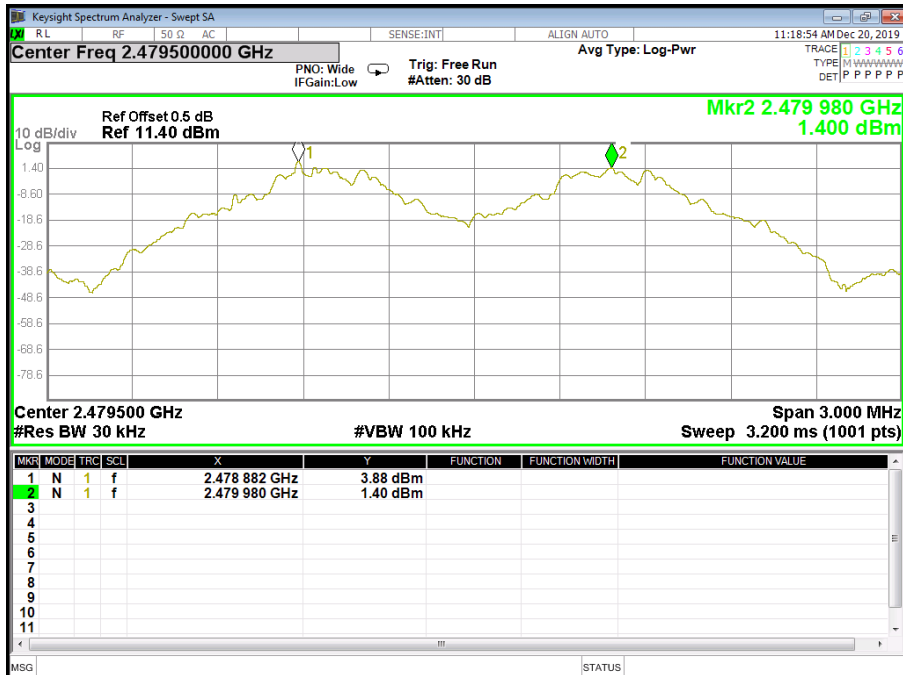



| | | | |
|--------------|---|--------------------|----------------------|
| Temperature: | 25°C | Relative Humidity: | 50% |
| Test Mode: | CH00 / CH39 / CH78 ($\pi/4$ -DQPSK(2Mbps) Mode) | Test Voltage: | DC 7.4V from battery |

| Frequency | Mark1 Frequency (MHz) | Mark2 Frequency (MHz) | Ch. Separation (MHz) | Limit (MHz) | Result |
|-----------|-----------------------|-----------------------|----------------------|-------------|----------|
| 2402 MHz | 2401.978 | 2402.974 | 0.996 | 0.948 | Complies |
| 2441 MHz | 2440.978 | 2441.977 | 0.999 | 0.951 | Complies |
| 2480 MHz | 2478.978 | 2479.977 | 0.999 | 0.955 | Complies |

For $\pi/4$ -DQPSK(2Mbps): Ch. Separation Limits: > two-thirds 20dB bandwidth

CH00 -2Mbps

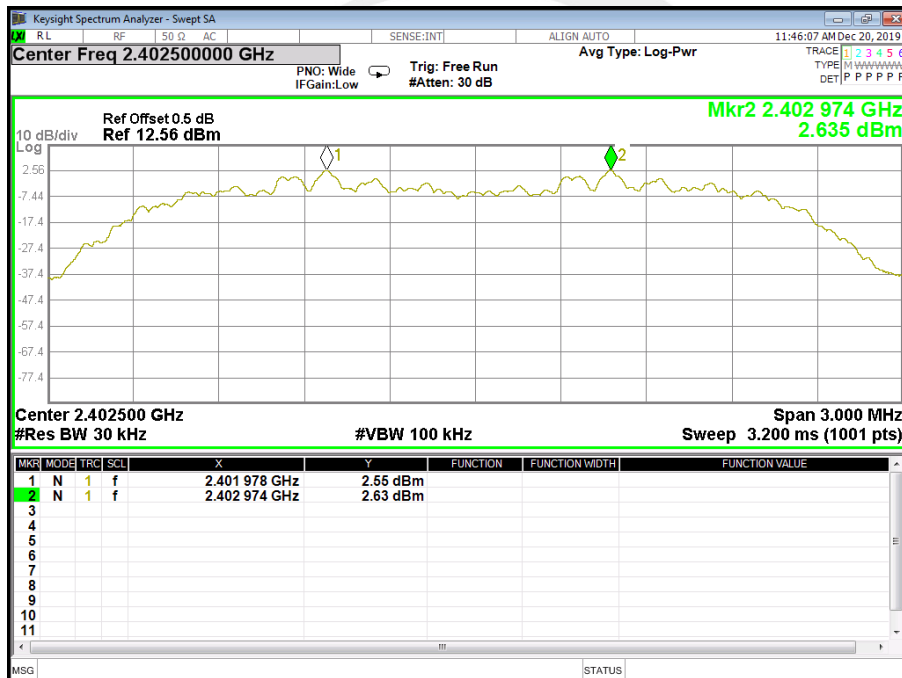



CH39 -2Mbps

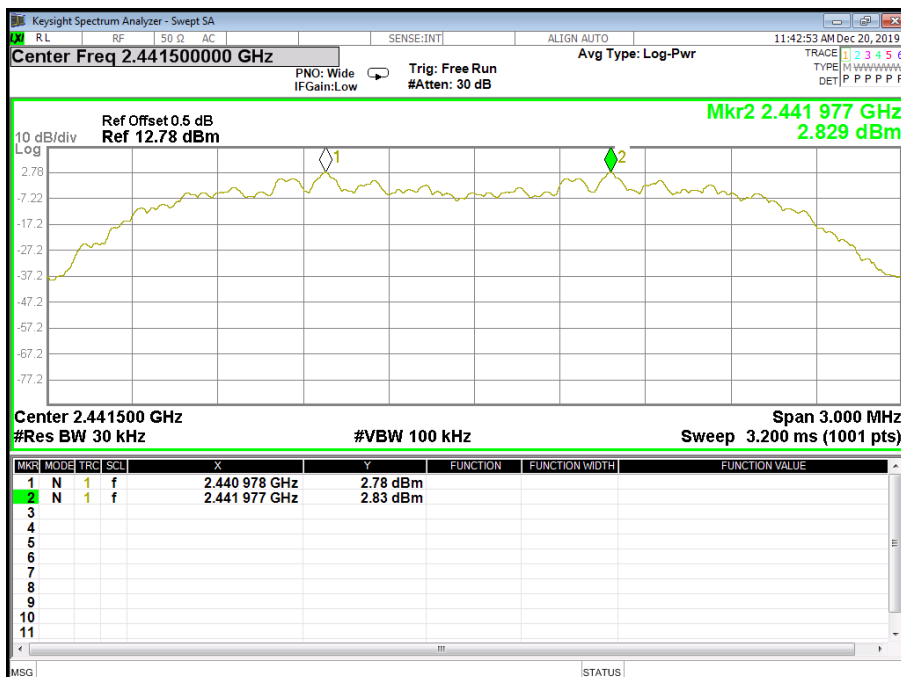

CH78 -2Mbps

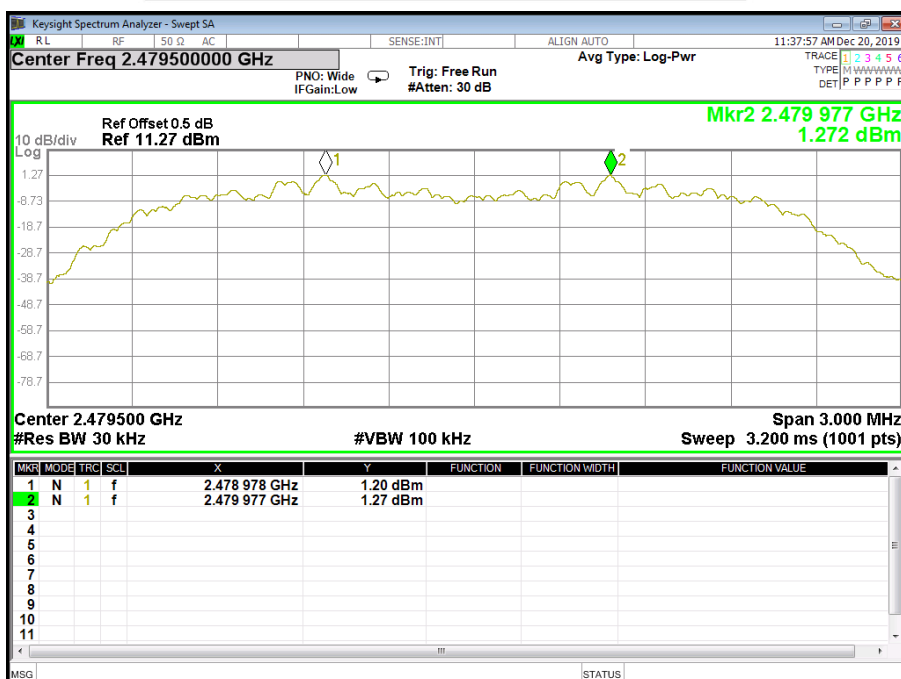



| | | | |
|--------------|--|--------------------|----------------------|
| Temperature: | 25°C | Relative Humidity: | 50% |
| Test Mode: | CH00 / CH39 / CH78 (8DPSK(3Mbps)Mode) | Test Voltage: | DC 7.4V from battery |

| Frequency | Mark1 Frequency (MHz) | Mark2 Frequency (MHz) | Ch. Separation (MHz) | Limit (MHz) | Result |
|-----------|-----------------------|-----------------------|----------------------|-------------|----------|
| 2402 MHz | 2401.978 | 2402.977 | 0.999 | 0.962 | Complies |
| 2441 MHz | 2440.978 | 2441.977 | 0.999 | 0.964 | Complies |
| 2480 MHz | 2478.975 | 2479.977 | 1.002 | 0.961 | Complies |

For 8DPSK(3Mbps):Ch. Separation Limits: > two-thirds 20dB bandwidth

CH00 -3Mbps

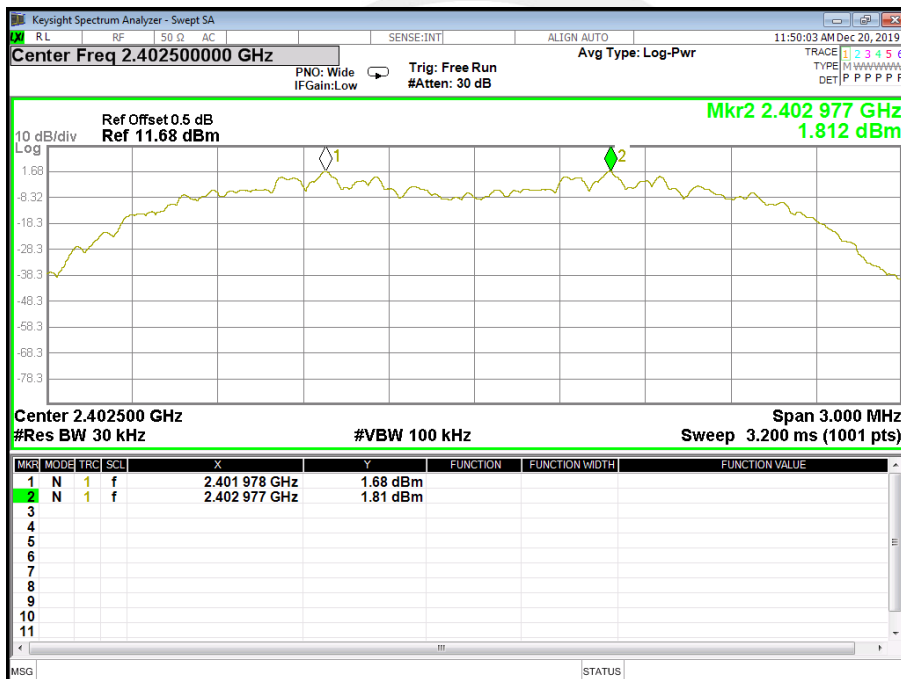



CH39 -3Mbps

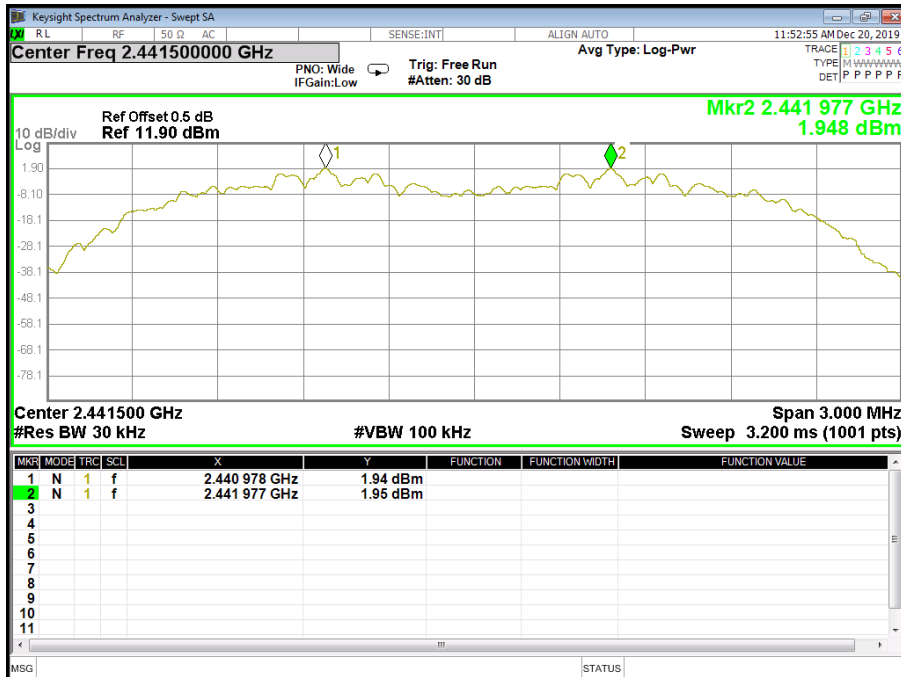

CH78 -3Mbps

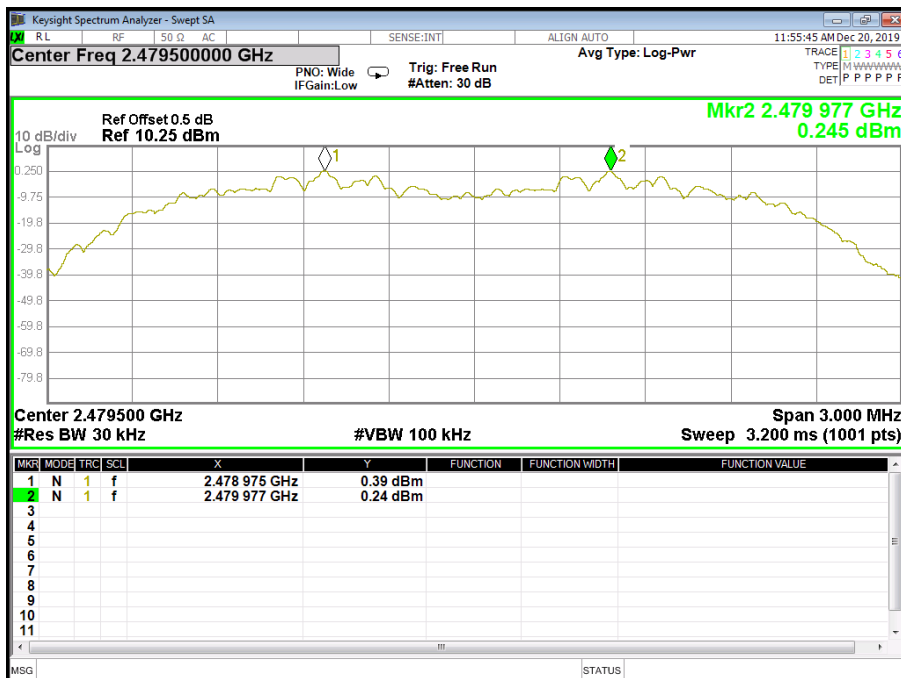



8. BANDWIDTH TEST

8.1 LIMIT

| FCC Part15 15.247, Subpart C RSS-247 Issue 2 | | | | |
|---|-----------|-------------------------|-------------------------|--------|
| Section | Test Item | Limit | FrequencyRange (MHz) | Result |
| 15.247 (a)(1) RSS-247 | Bandwidth | (20dB&99% bandwidth) | 2400-2483.5 | PASS |

| Spectrum Parameter | Setting |
|--------------------|---|
| Attenuation | Auto |
| Span Frequency | > Measurement Bandwidth or Channel Separation |
| RB | 30 kHz (20dB Bandwidth) / 30 kHz (Channel Separation) |
| VB | 100 kHz (20dB Bandwidth) / 100 kHz (Channel Separation) |
| Detector | Peak |
| Trace | Max Hold |
| Sweep Time | Auto |

8.2 TEST PROCEDURE

- The EUT was directly connected to the spectrum analyzer and antenna output port as show in the block diagram below.
- Spectrum Setting: RBW= 30KHz, VBW=100KHz, Sweep time = Auto.

8.3 TEST SETUP

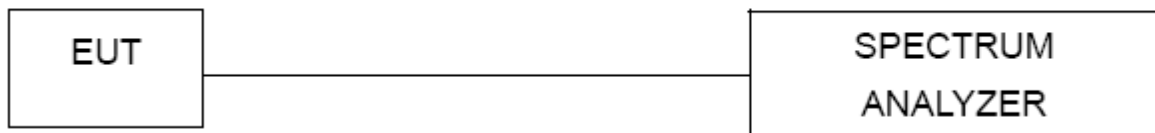

8.4 EUT OPERATION CONDITIONS

The EUT tested system was configured as the statements of 2.4 Unless otherwise a special operating condition is specified in the follows during the testing.



8.5 TEST RESULTS

| | | | |
|--------------|----------------------------------|--------------------|----------------------|
| Temperature: | 25°C | Relative Humidity: | 50% |
| Test Mode: | GFSK(1Mbps) CH00 / CH39 / C78 | Test Voltage: | DC 7.4V from battery |

| Frequency | 20dB Bandwidth (MHz) | 99% Bandwidth (MHz) | Result |
|-----------|----------------------|---------------------|--------|
| 2402 MHz | 0.9462 | 0.88995 | PASS |
| 2441 MHz | 0.9456 | 0.88811 | PASS |
| 2480 MHz | 0.9425 | 0.88793 | PASS |

CH00 -1Mbps

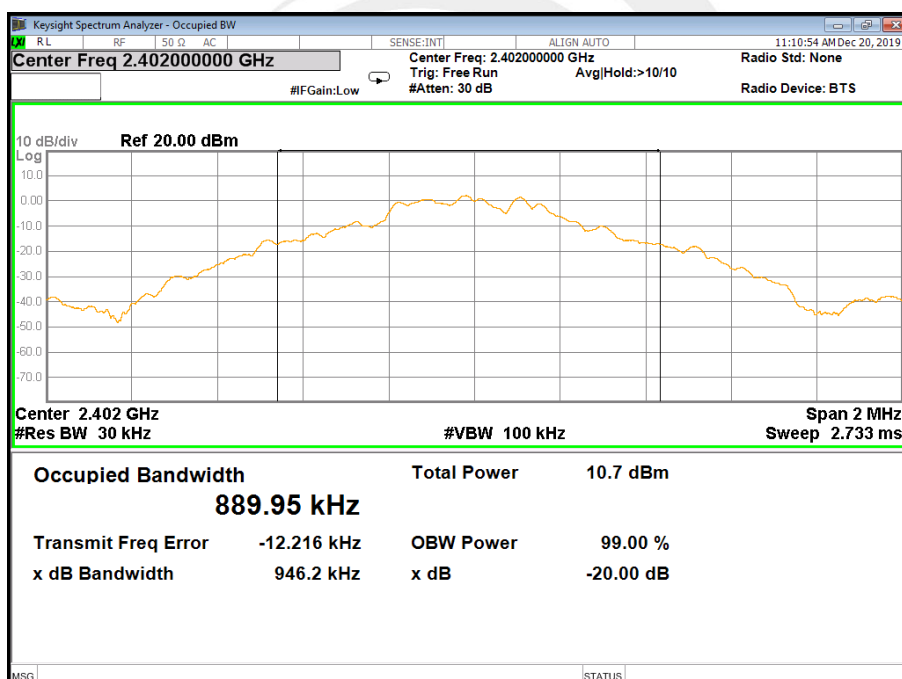



CH39 -1Mbps

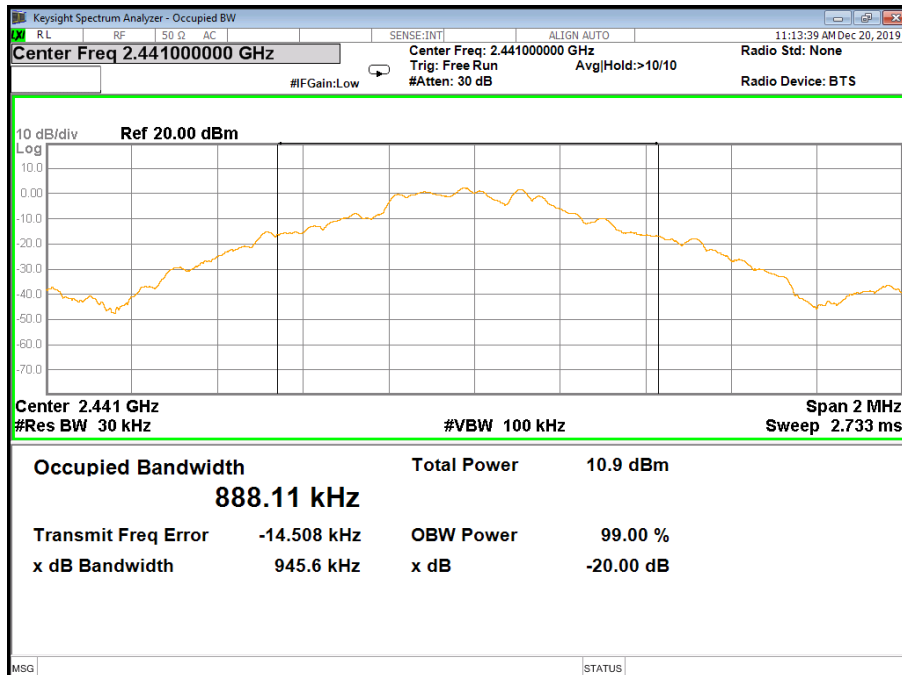

CH78 -1Mbps

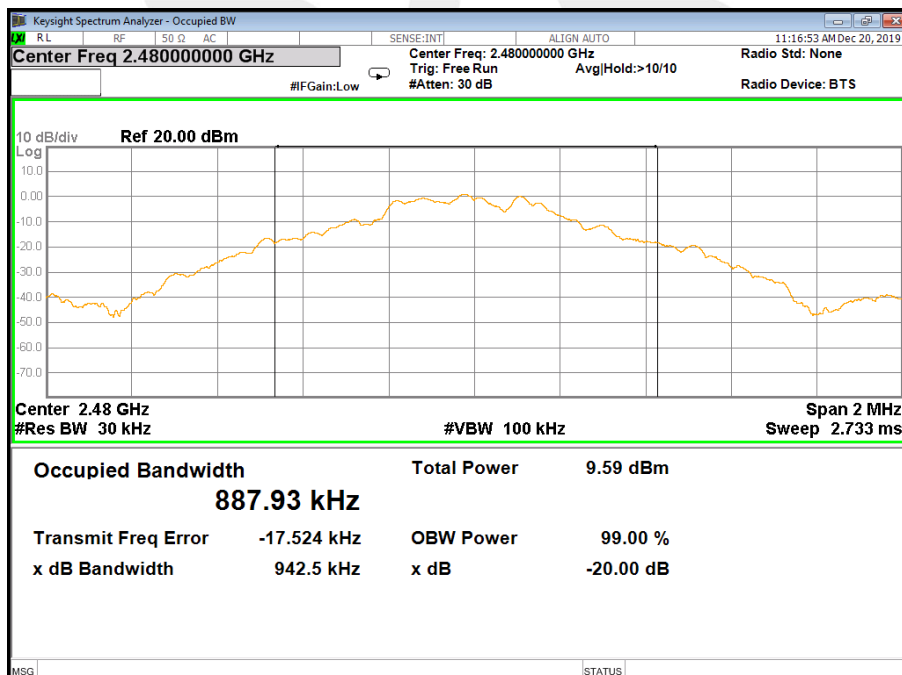



| | | | |
|--------------|--|--------------------|----------------------|
| Temperature: | 25°C | Relative Humidity: | 50% |
| Test Mode: | $\pi/4$ -DQPSK(2Mbps) CH00 / CH39 / C78 | Test Voltage: | DC 7.4V from battery |

| Frequency | 20dB Bandwidth (MHz) | 99% Bandwidth (MHz) | Result |
|-----------|----------------------|---------------------|--------|
| 2402 MHz | 1.422 | 1.337 | PASS |
| 2441 MHz | 1.427 | 1.3409 | PASS |
| 2480 MHz | 1.433 | 1.3428 | PASS |

CH00 -2Mbps

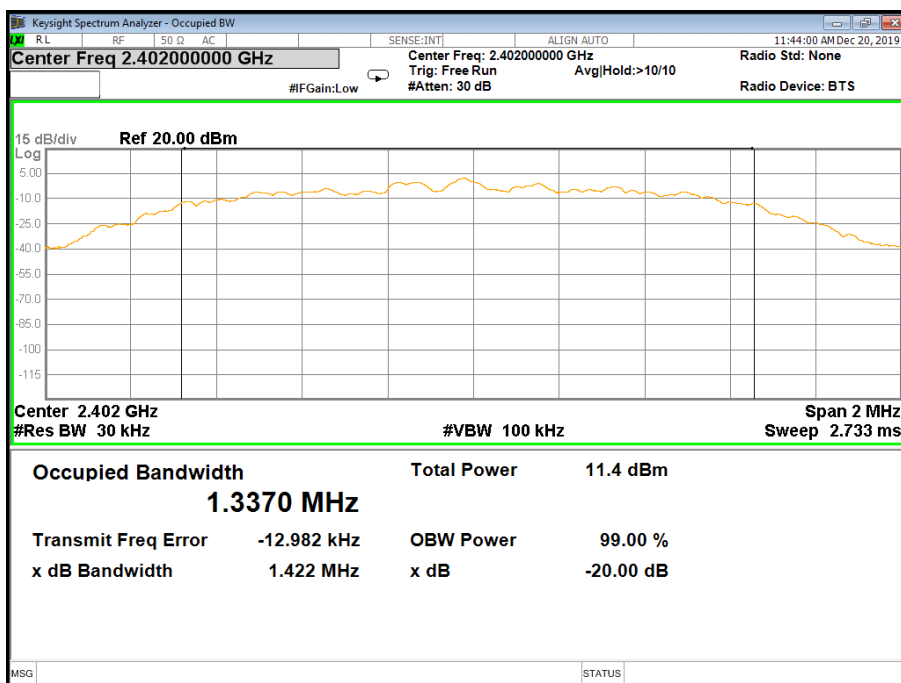



CH39 -2Mbps

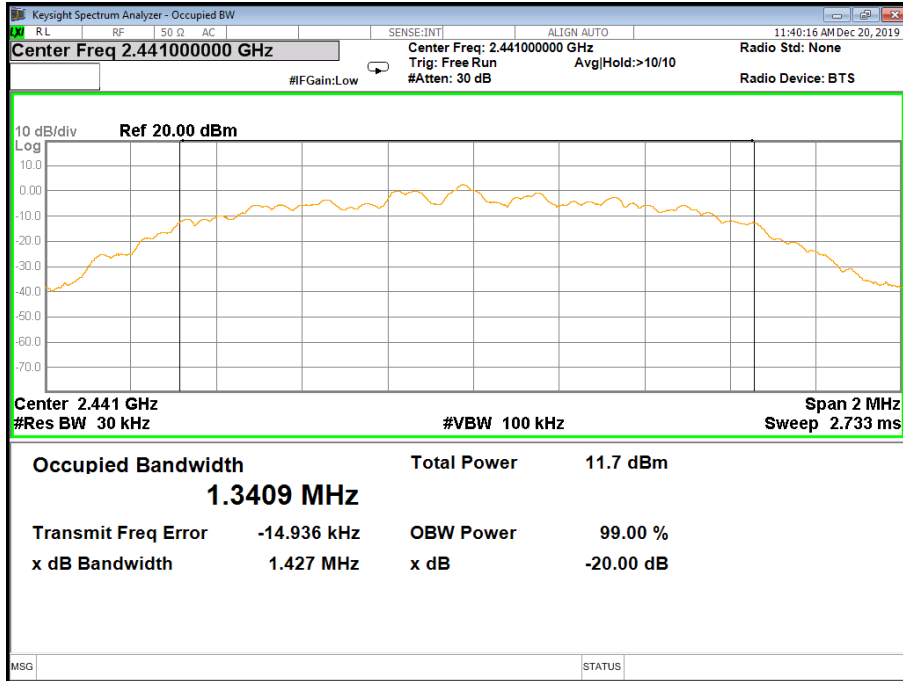

CH78 -2Mbps

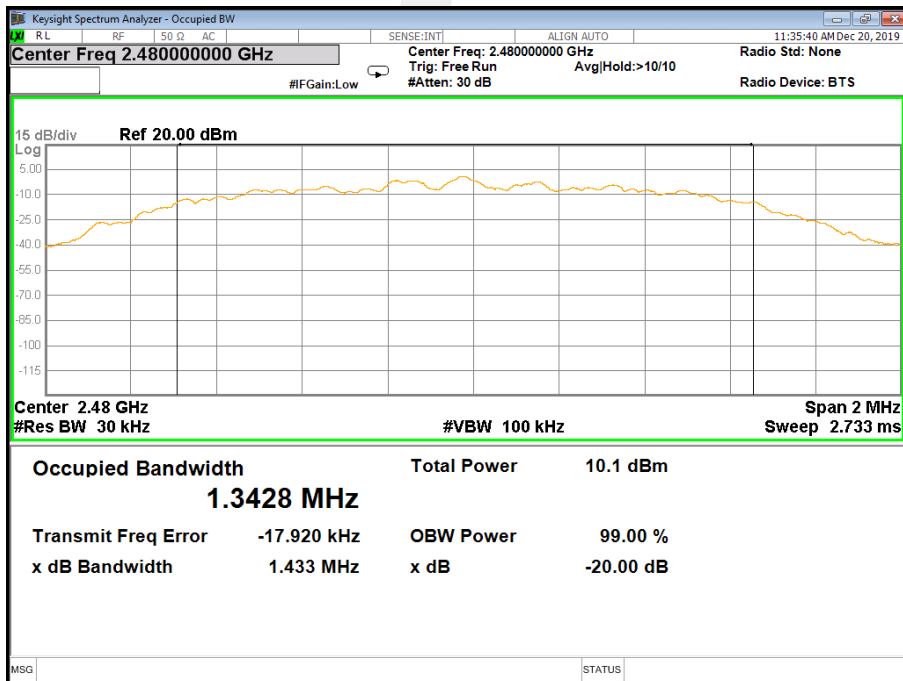



| | | | |
|--------------|------------------------------------|--------------------|----------------------|
| Temperature: | 25°C | Relative Humidity: | 50% |
| Test Mode: | 8DPSK(3Mbps) CH00 / CH39 / CH78 | Test Voltage: | DC 7.4V from battery |

| Frequency | 20dB Bandwidth (MHz) | 99% Bandwidth (MHz) | Result |
|-----------|----------------------|---------------------|--------|
| 2402 MHz | 1.443 | 1.3416 | PASS |
| 2441 MHz | 1.446 | 1.342 | PASS |
| 2480 MHz | 1.442 | 1.3434 | PASS |

CH00 -3Mbps

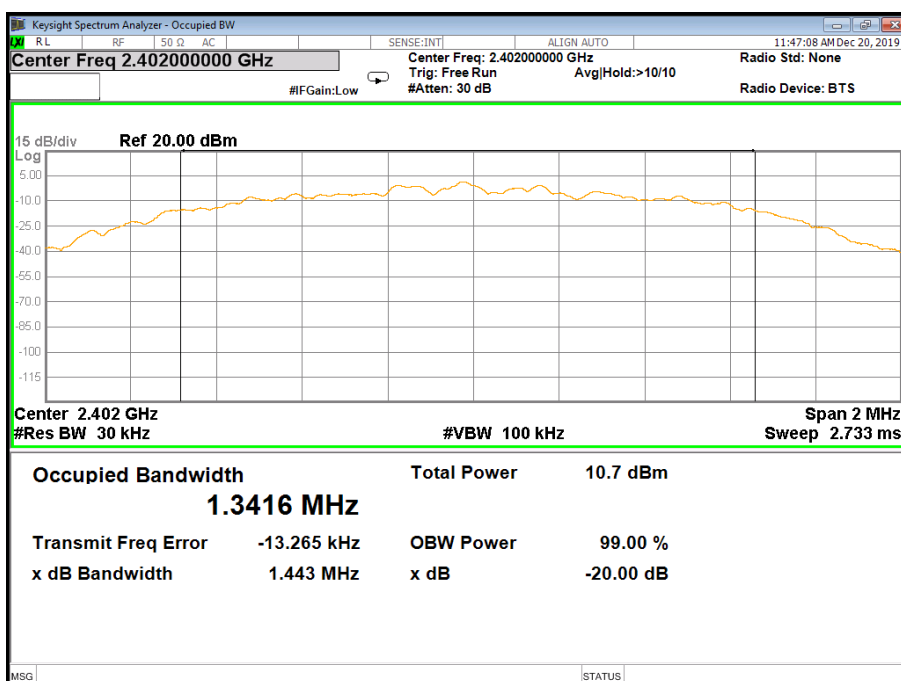



CH39 -3Mbps

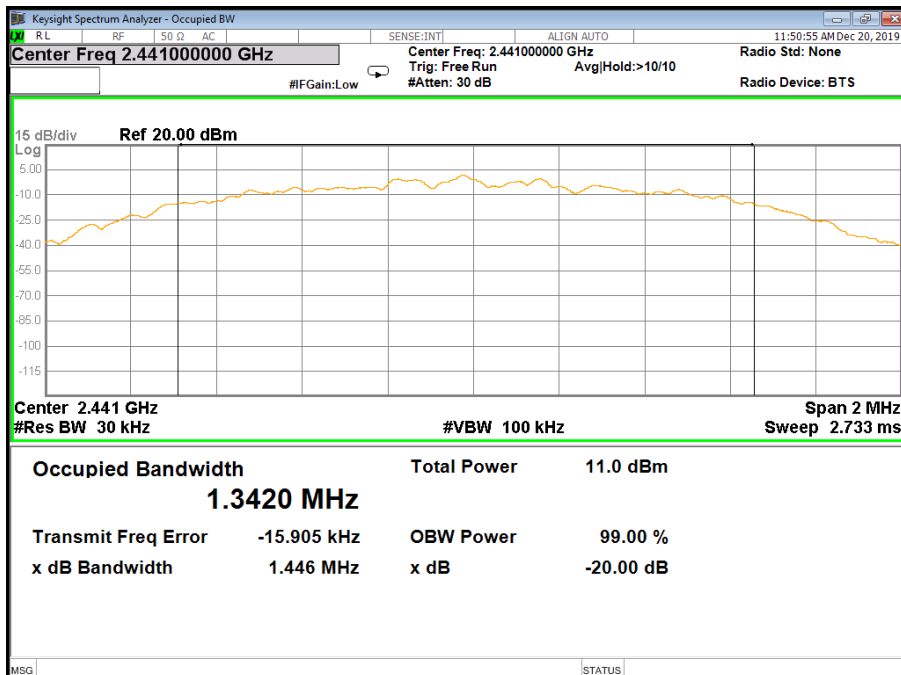

CH78 -3Mbps

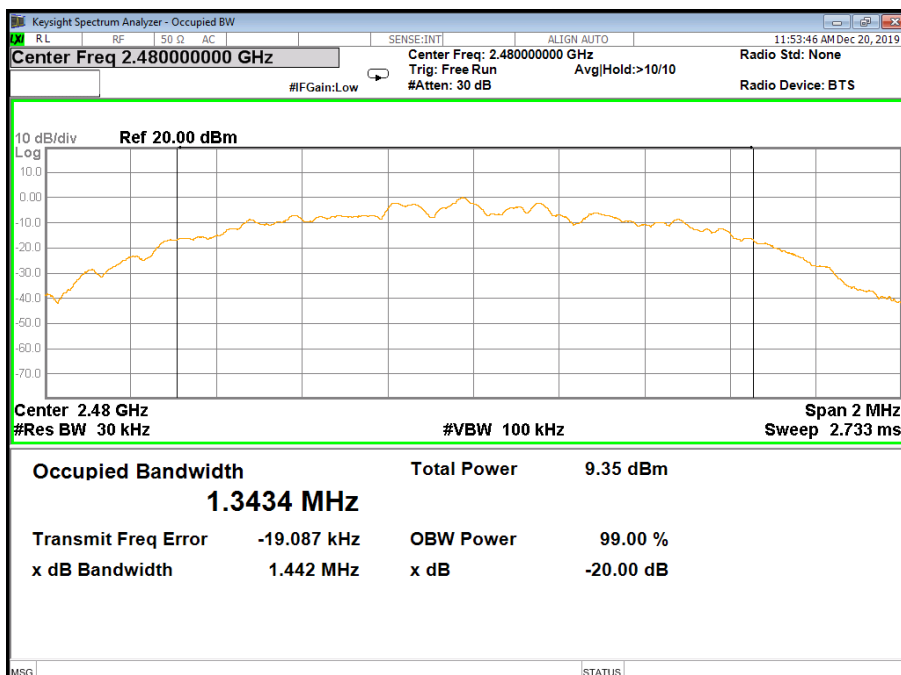



9. OUTPUT POWER TEST

9.1 LIMIT

| FCC Part 15.247, Subpart C | | | | |
|----------------------------|--------------|---|-----------------------|--------|
| Section | Test Item | Limit | Frequency Range (MHz) | Result |
| 15.247 (a)(1)&(b)(1) | Output Power | 1 W or 0.125W | 2400-2483.5 | PASS |
| | | if channel separation > 2/3 bandwidth provided the systems operate with an output power no greater than 125 mW (20.97dBm) | | |
| RSS-247 | EIRP | 4W | 2400-2483.5 | PASS |

9.2 TEST PROCEDURE

One of the following procedures may be used to determine the maximum peak conducted output power of a DTS EUT.

RBW \geq DTS bandwidth

The following procedure shall be used when an instrument with a resolution bandwidth that is greater than the DTS bandwidth is available to perform the measurement:

- Set the RBW \geq DTS bandwidth.
- Set VBW \geq [3 \times RBW].
- Set span \geq [3 \times RBW].
- Sweep time = auto couple.
- Detector = peak.
- Trace mode = max hold.
- Allow trace to fully stabilize.
- Use peak marker function to determine the peak amplitude level.

Integrated band power method:

The following procedure can be used when the maximum available RBW of the instrument is less than the

DTS bandwidth:

- Set the RBW = 1 MHz.
- Set the VBW \geq [3 \times RBW].
- Set the span \geq [1.5 \times DTS bandwidth].
- Detector = peak.
- Sweep time = auto couple.
- Trace mode = max hold.
- Allow trace to fully stabilize.
- Use the instrument's band/channel power measurement function with the band limits set equal to the DTS bandwidth edges (for some instruments, this may require a manual override to select the peak detector). If the instrument does not have a band power function, then sum the spectrum levels (in linear power units) at intervals equal to the RBW extending across the DTS channel bandwidth.

PKPM1 Peak power meter method:

The maximum peak conducted output power may be measured using a broadband peak RF power meter. The power meter shall have a video bandwidth that is greater than or equal to the DTS bandwidth and shall use a fast-responding diode detector.



9.3 TEST SETUP

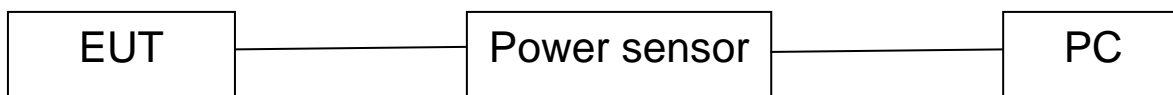

9.4 EUT OPERATION CONDITIONS

The EUT tested system was configured as the statements of 2.4 Unless otherwise a special operating condition is specified in the follows during the testing.





9.5 TEST RESULTS

| | | | |
|---------------|----------------------|--------------------|-----|
| Temperature: | 25°C | Relative Humidity: | 60% |
| Test Voltage: | DC 7.4V from battery | | |

| Mode | Channel Number | Frequency (MHz) | Peak Power | Average Power | Limit |
|----------|----------------|-----------------|------------|---------------|-------|
| | | | (dBm) | (dBm) | (dBm) |
| GFSK(1M) | 0 | 2402 | 4.73 | 3.58 | 30.00 |
| | 39 | 2441 | 4.69 | 3.56 | 30.00 |
| | 78 | 2480 | 3.59 | 2.42 | 30.00 |

Note: the channel separation >20dB bandwidth

| Mode | Channel Number | Frequency (MHz) | Peak Power | Average Power | Limit |
|--------------------|----------------|-----------------|------------|---------------|-------|
| | | | (dBm) | (dBm) | (dBm) |
| $\pi/4$ -DQPSK(2M) | 0 | 2402 | 6.82 | 3.61 | 20.97 |
| | 39 | 2441 | 7.04 | 3.65 | 20.97 |
| | 78 | 2480 | 6.00 | 2.54 | 20.97 |

Note: the channel separation >2/3 20dB bandwidth

| Mode | Channel Number | Frequency (MHz) | Peak Power | Average Power | Limit |
|------------|----------------|-----------------|------------|---------------|-------|
| | | | (dBm) | (dBm) | (dBm) |
| 8-DPSK(3M) | 0 | 2402 | 6.31 | 2.77 | 20.97 |
| | 39 | 2441 | 6.44 | 2.73 | 20.97 |
| | 78 | 2480 | 5.33 | 1.64 | 20.97 |

Note: the channel separation >2/3 20dB bandwidth



EIRP Power

| Mode | Channel Number | Frequency (MHz) | AV Power | Antenna Gain | EIRP Power | Limit |
|----------|----------------|-----------------|----------|--------------|------------|-------|
| | | | (dBm) | (dBi) | (dBm) | (dBm) |
| GFSK(1M) | 0 | 2402 | 3.58 | 0.00 | 3.58 | 36.00 |
| | 39 | 2441 | 3.56 | 0.00 | 3.56 | 36.00 |
| | 78 | 2480 | 2.42 | 0.00 | 2.42 | 36.00 |

| Mode | Channel Number | Frequency (MHz) | AV Power | Antenna Gain | EIRP Power | Limit |
|--------------------|----------------|-----------------|----------|--------------|------------|-------|
| | | | (dBm) | (dBi) | (dBm) | (dBm) |
| $\pi/4$ -DQPSK(2M) | 0 | 2402 | 3.61 | 0.00 | 3.61 | 36.00 |
| | 39 | 2441 | 3.65 | 0.00 | 3.65 | 36.00 |
| | 78 | 2480 | 2.54 | 0.00 | 2.54 | 36.00 |

| Mode | Channel Number | Frequency (MHz) | AV Power | Antenna Gain | EIRP Power | Limit |
|------------|----------------|-----------------|----------|--------------|------------|-------|
| | | | (dBm) | (dBi) | (dBm) | (dBm) |
| 8-DPSK(3M) | 0 | 2402 | 2.77 | 0.00 | 2.77 | 36.00 |
| | 39 | 2441 | 2.73 | 0.00 | 2.73 | 36.00 |
| | 78 | 2480 | 1.64 | 0.00 | 1.64 | 36.00 |



10. ANTENNA REQUIREMENT

10.1 STANDARD REQUIREMENT

15.203 and RSS-Gen Issue 5 requirement: For intentional device, according to 15.203 and RSS-Gen Issue 5: an intentional radiator shall be designed to ensure that no antenna other than that furnished by the responsible party shall be used with the device.

10.2 EUT ANTENNA

The EUT antenna is PIFA Antenna. It comply with the standard requirement.





11. FREQUENCY STABILITY

11.1 LIMITS OF FREQUENCY STABILITY MEASUREMENT

The frequency tolerance of the carrier signal shall be maintained within +/-0.02% of the operating frequency over a temperature variation of -30 degrees to 50 degrees C at normal supply voltage, and for a variation in primary supply voltage from 85% to 115% of the rated supply voltage at a temperature of 20 degrees.

11.2 TEST PROCEDURE

1. The EUT was placed inside the environmental test chamber and powered by nominal DC voltage.
2. Turn the EUT on and couple its output to spectrum analyzer.
3. Turn the EUT off and set the chamber to the highest temperature specified.
4. Allow sufficient time (approximately 30 min) for the temperature of the chamber to stabilize, turn the EUT on and measure the operating frequency after 2, 5, and 10 minutes.
5. Repeat step 2 and 3 with the temperature chamber set to the lowest temperature.
6. The test chamber was allowed to stabilize at +20 degree C for a minimum of 30 minutes. The supply voltage was then adjusted on the EUT from 85% to 115% and the frequency record.

11.3 TEST RESULT

Channel 39 (2441MHz)

Voltage vs. Frequency Stability

| Voltage(V) | Measurement Frequency(MHz) |
|--------------------|----------------------------|
| 8.51 | 2441.0023 |
| 7.4 | 2441.0017 |
| 6.29 | 2441.0022 |
| Max.Deviation(MHz) | 0.0023 |
| Max.Deviation(ppm) | 0.94 |

Rated working voltage: DC 7.4V

Temperature vs. Frequency Stability

| Temperature(°C) | Measurement Frequency(MHz) |
|--------------------|----------------------------|
| -30 | 2441.0032 |
| -20 | 2441.0030 |
| -10 | 2441.0025 |
| 0 | 2441.0032 |
| 10 | 2441.0027 |
| 20 | 2441.0029 |
| 30 | 2441.0023 |
| 40 | 2441.0023 |
| 50 | 2441.0029 |
| Max.Deviation(MHz) | 0.0032 |
| Max.Deviation(ppm) | 1.31 |



APPENDIX-PHOTOS OF TEST SETUP

Note: See test photos in setup photo document for the actual connections between Product and support equipment.

*****END OF THE REPORT*****

