



Test report No:
 NIE: 61457RRF.002A1

Test report
 Reference Standard:
 USA FCC Part 22
 CANADA RSS-132

(*) Identification of item tested	Data Logger
(*) Trademark	Danlaw
(*) Model and /or type reference	DL970
Other identification of the product	HW Version: 2.0 SW Version: 1.4.0.0 FCC ID: 2AD9I-DL970 IC: 20087-DL970
(*) Features	LTE, 3G, GPS, WLAN, Bluetooth (BLE)
Applicant	DANLAW INC 41211 Vincenti Court, Novi, Michigan 48375, USA
Test method requested, standard	USA FCC Part 22 (10-1-18 Edition). CANADA RSS-132 Issue 3, Jan. 2013. ANSI C63.26-2015. ANSI/TIA-603-E: 2016 KDB 971168 D01 Power Meas License Digital Systems v03r01, April. 2018.
Summary	IN COMPLIANCE
Approved by (name / position & signature)	José Carlos Luque RF Lab. Supervisor
Date of issue	2019-10-28
Report template No	FDT08_22 (*) "Data provided by the client"

Index

Competences and guarantees	3
General conditions	3
Uncertainty	3
Data provided by the client	3
Usage of samples	4
Test sample description	5
Identification of the client	6
Testing period and place	6
Document history	6
Environmental conditions	6
Remarks and comments	7
Testing verdicts	8
Summary	8
Appendix A: Test results for FCC PART 22 / RSS-132	9

Competences and guarantees

DEKRA Testing and Certification S.A.U. is a testing laboratory accredited by the National Accreditation Body (ENAC -Entidad Nacional de Acreditación), to perform the tests indicated in the Certificate No. 51/LE 147.

DEKRA Testing and Certification is a FCC-recognized accredited testing laboratory with appropriate scope of accreditation that include testing performed in this test report.

DEKRA Testing and Certification is an ISED-recognized accredited testing laboratory with appropriate scope of accreditation that include testing performed in this test report.

In order to assure the traceability to other national and international laboratories, DEKRA Testing and Certification S.A.U. has a calibration and maintenance program for its measurement equipment.

DEKRA Testing and Certification S.A.U. guarantees the reliability of the data presented in this report, which is the result of the measurements and the tests performed to the item under test on the date and under the conditions stated on the report and, it is based on the knowledge and technical facilities available at DEKRA Testing and Certification S.A.U. at the time of performance of the test.

DEKRA Testing and Certification S.A.U. is liable to the client for the maintenance of the confidentiality of all information related to the item under test and the results of the test.

The results presented in this Test Report apply only to the particular item under test established in this document. **IMPORTANT:** No parts of this report may be reproduced or quoted out of context, in any form or by any means, except in full, without the previous written permission of DEKRA Testing and Certification S.A.U.

General conditions

1. This report is only referred to the item that has undergone the test.
2. This report does not constitute or imply on its own an approval of the product by the Certification Bodies or competent Authorities.
3. This document is only valid if complete; no partial reproduction can be made without previous written permission of DEKRA Testing and Certification S.A.U.
4. This test report cannot be used partially or in full for publicity and/or promotional purposes without previous written permission of DEKRA Testing and Certification S.A.U. and the Accreditation Bodies.

Uncertainty

Uncertainty (factor $k=2$) was calculated according to the DEKRA Testing and Certification S.A.U. internal document PODT000.

Data provided by the client

The following data has been provided by the client:

1. Information relating to the description of the sample ("Identification of the item tested", "Trademark", "Model and/or type reference tested").
2. The sample of DL970 consists of a Data Logger developed to provide companies with an easy to install, wireless communication device for monitoring and logging vehicle network message data.

The Danlaw Data Logger provides:

- Support for all major passenger car & light truck protocols.
- Simple plug-n-go via the vehicle's OBDII connector.

- OBD Vehicle Data logging with real-time data stamp.
- LTE & 3G communication.
- Support for FTP, TCP/IP data transfer.
- Firmware Over-The-Air (FOTA) Re-flash.
- Rugged, compact field-hardened design.
- No external antenna connections needed.
- Completely self-contained.

DEKRA Testing and Certification S.A.U. declines any responsibility with respect to the information provided by the client and that may affect the validity of results.

Usage of samples

Samples undergoing test have been selected by: The client.

- Sample S/01 is composed of the following elements:

Control Nº	Description	Model	Serial Nº	Date of reception
61457C/003	Data Logger	DL970	5337	2019/07/23

Sample S/01 has undergone the following test(s): All radiated tests indicated in Appendix A.

- Sample S/02 is composed of the following elements:

Control Nº	Description	Model	Serial Nº	Date of reception
61457C/001	Data Logger	DL970	--	2019/06/20

Sample S/02 has undergone the following test(s): All conducted tests indicated in Appendix A.

Test sample description

Ports..... .: :	Port name and description	Cable					
		Specified max length [m]	Attached during test	Shielded	Coupled to patient ⁽³⁾		
	USB connector; access virtual COM port	1.70	<input checked="" type="checkbox"/>	<input type="checkbox"/>	<input type="checkbox"/>		
Supplementary information to the ports..... :	-						
Rated power supply	Voltage and Frequency		Reference poles				
			L1	L2	L3	N	PE
	<input type="checkbox"/>	AC:	<input type="checkbox"/>	<input type="checkbox"/>	<input type="checkbox"/>	<input type="checkbox"/>	<input type="checkbox"/>
	<input checked="" type="checkbox"/>	DC: $V_{nom} = 12\text{ V}$; $V_{low} = 9\text{ V}$; $V_{high} = 15\text{ V}$					
Rated Power	Data not provided						
Clock frequencies..... :	Data not provided						
Other parameters	Data not provided						
Software version	1.4.0.0						
Hardware version	2.0						
Dimensions in cm (W x H x D)	4.75 x 4.4 x 2.3						
Mounting position	<input checked="" type="checkbox"/>	Other: Vehicle					
Modules/parts..... :	Module/parts of test item		Type	Manufacturer			
	WLAN/BLT module		QCA9377	Qualcomm			
	3G/LTE/GPS module		MDM9207	Qualcomm			
Accessories (not part of the test item)	Description		Type	Manufacturer			
	-						
Documents as provided by the applicant..... :	Description		File name	Issue date			
	PICS						
	User Manual						
	Instruction for testing						

Identification of the client

DANLAW INC
41211 Vincenti Court, Novi, Michigan 48375, USA

Testing period and place

Test Location	DEKRA Testing and Certification S.A.U.
Date (start)	2019-08-09
Date (finish)	2019-09-27

Document history

Report number	Date	Description
61457RRF.002	2019-10-07	First release
61457RRF.002A1	2019-10-28	Second release. RF Output Power measurements added on the modulation 16QAM. All results for the CANADA RSS-132 Issue 3 standard added.

Environmental conditions

In the control chamber, the following limits were not exceeded during the test:

Temperature	Min. = 15 °C Max. = 35 °C
Relative humidity	Min. = 20 % Max. = 75 %

In the semianechoic chamber, the following limits were not exceeded during the test.

Temperature	Min. = 15 °C Max. = 35 °C
Relative humidity	Min. = 20 % Max. = 75 %
Air pressure	Min. = 860 mbar Max. = 1060 mbar

In the chamber for conducted measurements, the following limits were not exceeded during the test:

Temperature	Min. = 15 °C Max. = 35 °C
Relative humidity	Min. = 20 % Max. = 35
Air pressure	Min. = 860 mbar Max. = 1060 mbar

Remarks and comments

The tests have been performed by the technical personnel: José Manuel Jiménez, José Alberto Aranda, Miguel Ángel Torres, Verónica García, Jaime Barranquero, Cristina Calle, Jesús García.

Used instrumentation:

Conducted Measurements

	Last Calibration	Due Calibration
1. Chamber HERAEUS VMT 04/35	2018/06	2020/06
2. Wideband Radio Communication Tester ROHDE AND SCHWARZ CMW500	2019/05	2020/05
3. Signal Analyzer 20 Hz to 8 GHz ROHDE AND SCHWARZ FSQ8	2018/08	2020/08
4. DC Power Supply 40V/40A Rohde & Schwarz NGPE40	2018/02	2021/02
5. Signal and Spectrum Analyzer ROHDE AND SCHWARZ FSV40	2019/09	2021/09
6. EMI Test Receiver 7 GHz ROHDE AND SCHWARZ ESR7	2018/10	2020/10
7. Spectrum analyser Agilent PSA E4440A	2017/10	2019/10

Radiated Measurements

	Last Calibration	Due Calibration
1. Semianechoic Absorber Lined Chamber ETS LINDGREN FACT 3 200 STP	N.A.	N.A.
2. Wideband Radio Communication Tester ROHDE AND SCHWARZ CMW500	2019/05	2020/05
3. EMI Test Receiver ROHDE AND SCHWARZ ESR7	2018/10	2020/10
4. Biconical/Log Antenna ETS LINDGREN 3142E	2017/04	2020/04
5. Signal and Spectrum Analyzer ROHDE AND SCHWARZ FSW50	2018/02	2020/02
6. RF pre-amplifier 1-18 GHz Bonn Elektronik BLMA 0118-1M	2019/04	2020/04
7. Broadband Horn antenna 1-18 GHz SCHWARZBECK MESS-ELEKTRONIK BBHA 9120 D	2016/11	2019/11
8. DC Power Supply Keysight Technologies U8002A	---	---
9. Digital multimeter FLUKE 179	2019/06	2020/06
8. DC Power Supply 30V/5A KEYSIGHT TECHNOLOGIES, U8002A	N.A.	N.A.

Testing verdicts

Not applicable:	N/A
Pass:	P
Fail:	F
Not measured:	N/M

Summary

FCC PART 22 / RSS-132 PARAGRAPH		
Requirement – Test case	Verdict	Remark
Clause 22.913/RSS-132 Clause 5.4: RF output power	P	(1)
Clause 2.1047/RSS-132 Clause 5.2: Modulation characteristics	P	(1)
Clause 22.355/RSS-132 Clause 5.3: Frequency stability	P	(1)
Clause 2.1049: Occupied Bandwidth	P	(1)
Clause 22.917/RSS-132 Clause 5.5: Spurious emissions at antenna terminals	P	(1)
Clause 22.917/RSS-132 Clause 5.5: Radiated emissions	P	(1)
<u>Supplementary information and remarks:</u>		
<p>(1) HSDPA modulation mode has not been tested to prove USA FCC Part 22 compliance because it is an improved mode of operation only for Downlink (UE reception), but using the normal WCDMA mode for UL (Up Link, UE transmission). Therefore HSDPA has no associated a Power class or modulation scheme different than WCDMA mode for the UL transmission.</p> <p>Taking into account the above comments, testing in HSDPA modulation mode is redundant for FCC Part 22 as it is the same as WCDMA mode as long as UE transmission is concerned. WCDMA modulation mode has been tested as indicated on the present test report.</p>		

Appendix A: Test results for FCC PART 22 / RSS-132

INDEX

TEST CONDITIONS	11
RF Output Power	11
Frequency Stability	17
Modulation Characteristics	29
Occupied Bandwidth	31
Spurious emissions at antenna terminals	52
Spurious emissions at antenna terminals at Block Edges	64
Radiated emissions	68

TEST CONDITIONS

POWER SUPPLY (V):

Vn: 12 Vdc
 Vmin: 9 Vdc (*)
 Vmax: 15 Vdc (*)

Type of Power Supply: External power supply (car battery).

The subscripts 'n', 'min' and 'max' indicate voltage test conditions (nominal, minimum and maximum respectively), as declared by the applicant.

ANTENNA:

LOW Bands	GAIN	ANTENNA TYPE
3G Band V	+2.36 dBi	Internal (embedded in the plastics of the device)
LTE Band 5	+2.36 dBi	Internal (embedded in the plastics of the device)

TEST FREQUENCIES:

3G Band V:

WCDMA and HSUPA MODULATIONS:

Lowest Channel (4132): 826.4 MHz
 Middle Channel (4183): 836.6 MHz
 Highest Channel (4233): 846.6 MHz

LTE Band 5. QPSK AND 16QAM MODULATIONS:

	Channel (Frequency)			
	BW = 1.4 MHz	BW = 3 MHz	BW = 5 MHz	BW = 10 MHz
Lowest	20407 (824.7 MHz)	20415 (825.5 MHz)	20425 (826.5 MHz)	20450 (829 MHz)
Middle	20525 (836.5 MHz)	20525 (836.5 MHz)	20525 (836.5 MHz)	20525 (836.5 MHz)
Highest	20643 (848.3 MHz)	20635 (847.5 MHz)	20625 (846.5 MHz)	20600 (844 MHz)

Note: LTE Category 1 device, so for BW=10 MHz the 16QAM modulation does not support transmission in RB=All.

RF Output Power

SPECIFICATION:

FCC §2.1046 and FCC §22.913. The Effective Radiated Power (E.R.P.) of mobile transmitter and auxiliary test transmitter must not exceed 7 Watts (38.45 dBm E.R.P.).

RSS-132. Clause 5.4. The equivalent isotropically radiated power (e.i.r.p.) for mobile equipment shall not exceed 11.5 watts (38.45 dBm E.R.P.).

In addition, the peak-to-average power ratio (PAPR) of the transmitter shall not exceed 13 dB for more than 0.1% of the time using a signal corresponding to the highest PAPR during periods of continuous transmission.

METHOD:

The conducted RF output power measurements were made at the RF output terminals of the EUT using the power meter of the Universal Radio Communication tester R&S CMU200 and CMW500, selecting maximum transmission power of the EUT and different modes of modulation.

The peak-to-average power ratio (PAPR) is measured using an attenuator, power splitter and spectrum analyser with a Complementary Cumulative Distribution Function implemented.

The maximum equivalent isotropically radiated power (e.i.r.p.) is calculated by adding the declared maximum antenna gain (dBi).

The maximum effective radiated power e.r.p. is calculated from the maximum equivalent isotropically radiated power (e.i.r.p.) by subtracting 2.15 dB:

$$E.R.P. = E.I.R.P. - 2.15 \text{ dB}$$

TEST SETUP:

1. CONDUCTED AVERAGE POWER:

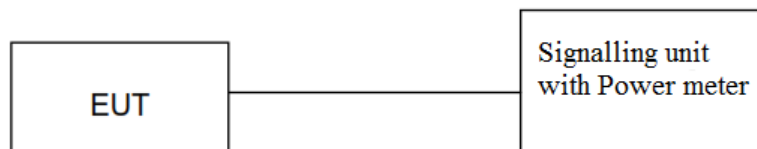

2. PEAK-TO-AVERAGE POWER RATIO (PAPR):

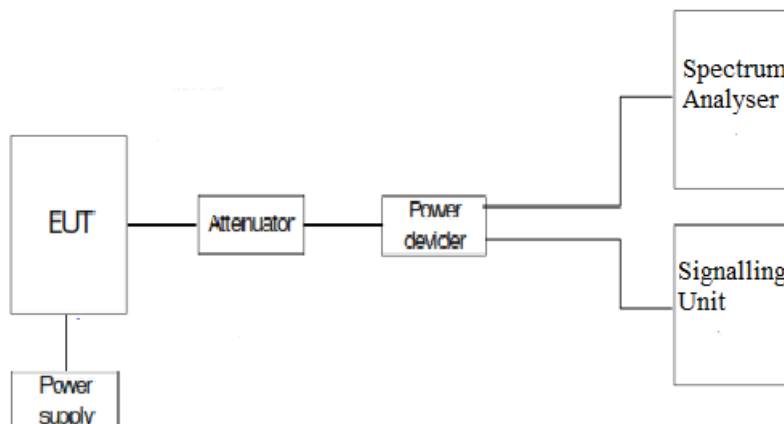

RESULTS:

1. AVERAGE POWER:

3G Band V:

3G Band V. WCDMA MODULATION.

Channel	Lowest	Middle	Highest
Maximum declared antenna gain (dBi)	2.36	2.36	2.36
Measured maximum average power (dBm) at antenna port	22.30	22.37	22.27
Maximum effective isotropically radiated power (E.I.R.P.) (dBm)	24.66	24.73	24.63
Maximum effective radiated power E.R.P. (dBm)	22.51	22.58	22.48
PAPR (dB)	2.94	2.81	2.81
Measurement uncertainty (dB)	<±0.66		

3G Band V. HSUPA MODULATION.

Channel	Lowest	Middle	Highest
Maximum declared antenna gain (dBi)	2.36	2.36	2.36
Measured maximum average power (dBm) at antenna port	20.85	20.64	20.63
Maximum equivalent isotropically radiated power (E.I.R.P.) (dBm)	23.21	23.00	22.99
Maximum effective radiated power E.R.P. (dBm)	21.06	20.85	20.84
PAPR (dB)	3.31	3.34	3.22
Measurement uncertainty (dB)	<±0.66		

Verdict: PASS

LTE Band 5:

LTE Band 5. QPSK MODULATION. Bandwidth = 1.4 MHz.

Channel	Lowest	Middle	Highest
Maximum declared antenna gain (dBi)	2.36	2.36	2.36
Measured maximum average power (dBm) at antenna port	21.99	22.77	21.80
Maximum equivalent isotropically radiated power (E.I.R.P.) (dBm)	24.35	25.13	24.16
Maximum effective radiated power E.R.P. (dBm)	22.20	22.98	22.01
PAPR (dB)	(*)	(*)	(*)
Measurement uncertainty (dB)	<±0.66		

Worst case AVERAGE POWER: Modulation QPSK. RB Size: 1. RB Offset: 5.

(*): Preliminary measurements determined PAPR of 16QAM as the worst case.

LTE Band 5. 16QAM MODULATION. Bandwidth = 1.4 MHz.

Channel	Lowest	Middle	Highest
Maximum declared antenna gain (dBi)	2.36	2.36	2.36
Measured maximum average power (dBm) at antenna port	21.87	21.67	20.67
Maximum equivalent isotropically radiated power (E.I.R.P.) (dBm)	24.23	24.03	23.03
Maximum effective radiated power E.R.P. (dBm)	22.08	21.88	20.88
PAPR (dB)	5.82	5.58	5.32
Measurement uncertainty (dB)	<±0.66		

Worst case AVERAGE POWER: Modulation 16QAM. RB Size: 1. RB Offset: 2.
 Worst case PAPR: Modulation 16QAM. RB Size: 6. RB Offset: 0.

LTE Band 5. QPSK MODULATION. Bandwidth = 3 MHz.

Channel	Lowest	Middle	Highest
Maximum declared antenna gain (dBi)	2.36	2.36	2.36
Measured maximum average power (dBm) at antenna port	21.93	22.63	21.72
Maximum equivalent isotropically radiated power (E.I.R.P.) (dBm)	24.29	24.99	24.08
Maximum effective radiated power E.R.P. (dBm)	22.14	22.84	21.93
PAPR (dB)	(*)	(*)	(*)
Measurement uncertainty (dB)	<±0.66		

Worst case AVERAGE POWER: Modulation QPSK. RB Size: 1. RB Offset: 0.

(*): Preliminary measurements determined PAPR of 16QAM as the worst case.

LTE Band 5. 16QAM MODULATION. Bandwidth = 3 MHz.

Channel	Lowest	Middle	Highest
Maximum declared antenna gain (dBi)	2.36	2.36	2.36
Measured maximum average power (dBm) at antenna port	21.95	21.74	21.21
Maximum equivalent isotropically radiated power (E.I.R.P.) (dBm)	24.31	24.1	23.57
Maximum effective radiated power E.R.P. (dBm)	22.16	21.95	21.42
PAPR (dB)	5.91	5.87	5.69
Measurement uncertainty (dB)	<±0.66		

Worst case AVERAGE POWER:
 Worst case PAPR:

Modulation 16QAM. RB Size: 1. RB Offset: 7.
 Modulation 16QAM. RB Size: 15. RB Offset: 0.

LTE Band 5. QPSK MODULATION. Bandwidth = 5 MHz.

Channel	Lowest	Middle	Highest
Maximum declared antenna gain (dBi)	2.36	2.36	2.36
Measured maximum average power (dBm) at antenna port	22.29	22.80	21.77
Maximum equivalent isotropically radiated power (E.I.R.P.) (dBm)	24.65	25.16	24.13
Maximum effective radiated power E.R.P. (dBm)	22.50	23.01	21.98
PAPR (dB)	(*)	(*)	(*)
Measurement uncertainty (dB)	<±0.66		

Worst case AVERAGE POWER:

Modulation QPSK. RB Size: 1. RB Offset: 12.

(*): Preliminary measurements determined PAPR of 16QAM as the worst case.

LTE Band 5. 16QAM MODULATION. Bandwidth = 5 MHz.

Channel	Lowest	Middle	Highest
Maximum declared antenna gain (dBi)	2.36	2.36	2.36
Measured maximum average power (dBm) at antenna port	21.63	21.13	21
Maximum equivalent isotropically radiated power (E.I.R.P.) (dBm)	23.99	23.49	23.36
Maximum effective radiated power E.R.P. (dBm)	21.84	21.34	21.21
PAPR (dB)	5.79	5.66	5.61
Measurement uncertainty (dB)	<±0.66		

Worst case AVERAGE POWER:
 Worst case PAPR:

Modulation 16QAM. RB Size: 1. RB Offset: 12.
 Modulation 16QAM. RB Size: 25. RB Offset: 0.

LTE Band 5. QPSK MODULATION. Bandwidth = 10 MHz.

Channel	Lowest	Middle	Highest
Maximum declared antenna gain (dBi)	2.36	2.36	2.36
Measured maximum average power (dBm) at antenna port	22.10	22.69	21.90
Maximum equivalent isotropically radiated power (E.I.R.P.) (dBm)	24.46	25.05	24.26
Maximum effective radiated power E.R.P. (dBm)	22.31	22.90	22.11
PAPR (dB)	4.78	5.03	4.95
Measurement uncertainty (dB)	<±0.66		

Worst case AVERAGE POWER: Modulation QPSK. RB Size: 1. RB Offset: 0.
 Worst case PAPR: Modulation QPSK. RB Size: 50. RB Offset: 0.

(*): Not supported the modulation 16QAM.

2. PEAK-TO-AVERAGE POWER RATIO (PAPR):

3G Band V. WCDMA MODULATION.

Lowest Channel:

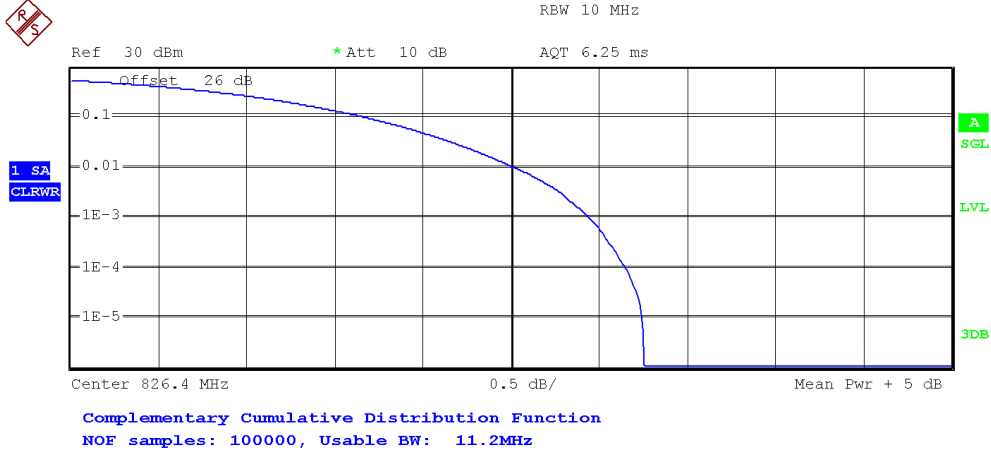

Trace 1	
Mean	23.08 dBm
Peak	26.34 dBm
Crest	3.26 dB
10 %	1.67 dB
1 %	2.52 dB
.1 %	2.94 dB
.01 %	3.15 dB

Middle Channel:

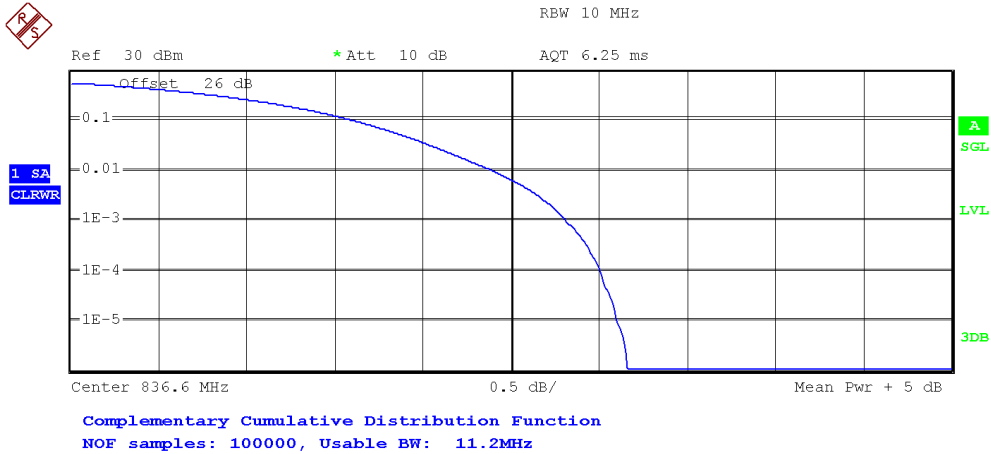

Trace 1	
Mean	23.12 dBm
Peak	26.28 dBm
Crest	3.17 dB
10 %	1.60 dB
1 %	2.39 dB
.1 %	2.81 dB
.01 %	3.00 dB

Highest Channel:

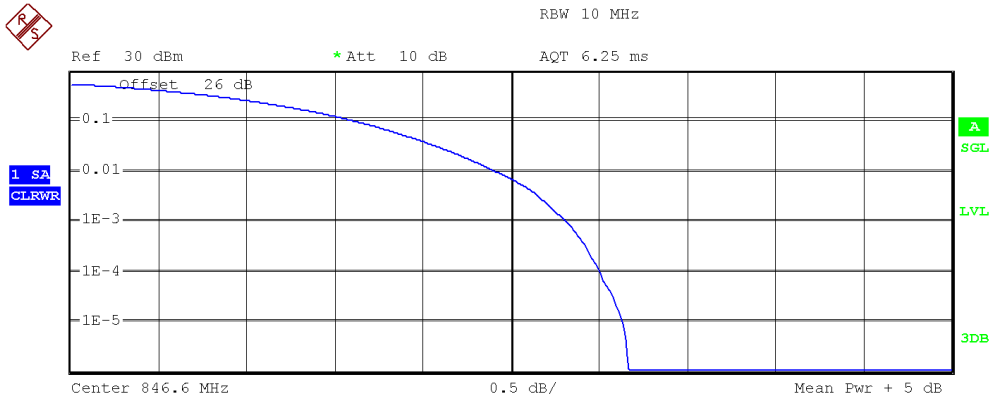

Complementary Cumulative Distribution Function
 NOF samples: 100000, Usable BW: 11.2MHz

Trace 1	
Mean	22.78 dBm
Peak	25.95 dBm
Crest	3.17 dB
10 %	1.62 dB
1 %	2.41 dB
.1 %	2.81 dB
.01 %	3.00 dB

3G Band V. HSUPA MODULATION.

Lowest Channel:

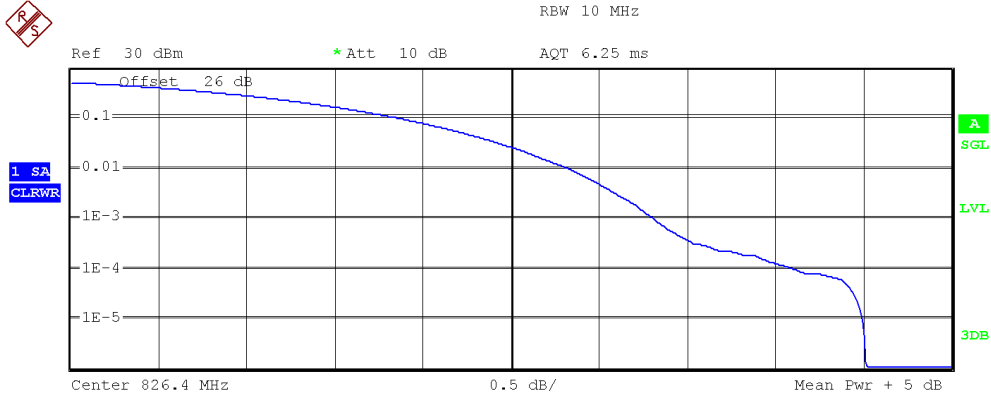

Complementary Cumulative Distribution Function
 NOF samples: 100000, Usable BW: 11.2MHz

Trace 1
 Mean 21.61 dBm
 Peak 26.13 dBm
 Crest 4.52 dB

10 %	1.87 dB
1 %	2.82 dB
.1 %	3.31 dB
.01 %	4.09 dB

Middle Channel:

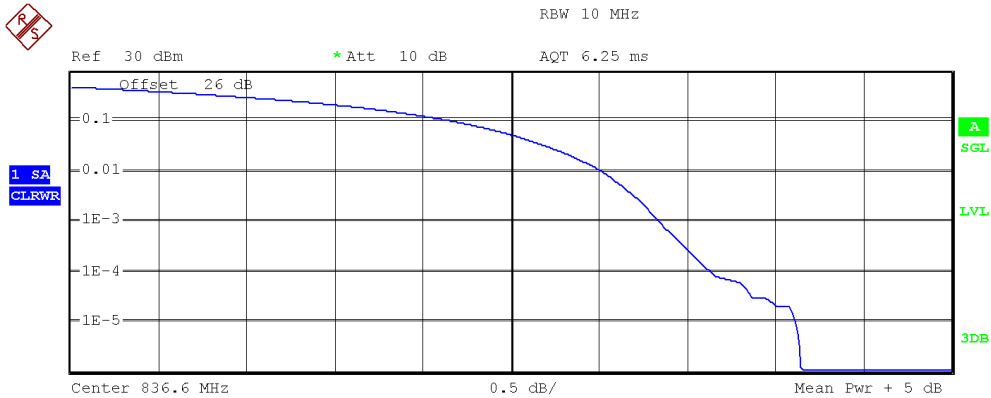

Complementary Cumulative Distribution Function
 NOF samples: 100000, Usable BW: 11.2MHz

Trace 1
 Mean 21.43 dBm
 Peak 25.58 dBm
 Crest 4.15 dB

10 %	2.17 dB
1 %	3.01 dB
.1 %	3.34 dB
.01 %	3.63 dB

Highest Channel:

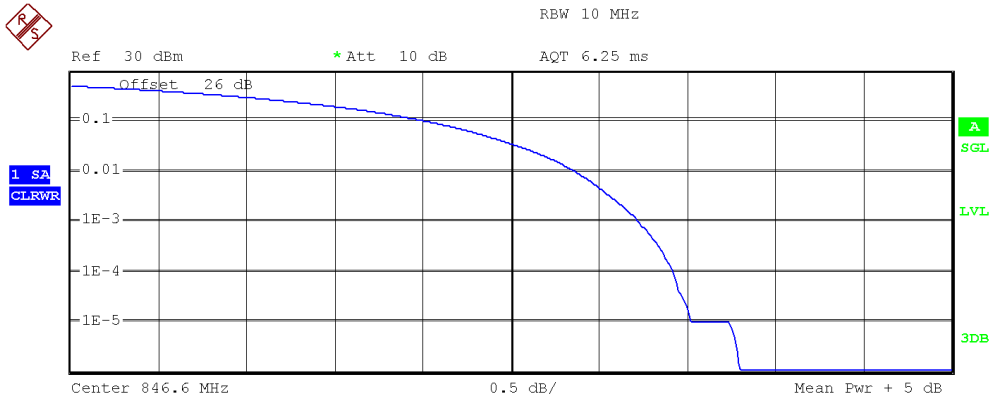

Complementary Cumulative Distribution Function
 NOF samples: 100000, Usable BW: 11.2MHz

Trace 1	
Mean	21.16 dBm
Peak	24.96 dBm
Crest	3.80 dB
10 %	2.02 dB
1 %	2.86 dB
.1 %	3.22 dB
.01 %	3.42 dB

LTE Band 5. Bandwidth = 1.4 MHz. Modulation 16 QAM. RB Size: 6. RB Offset: 0.

Lowest Channel:

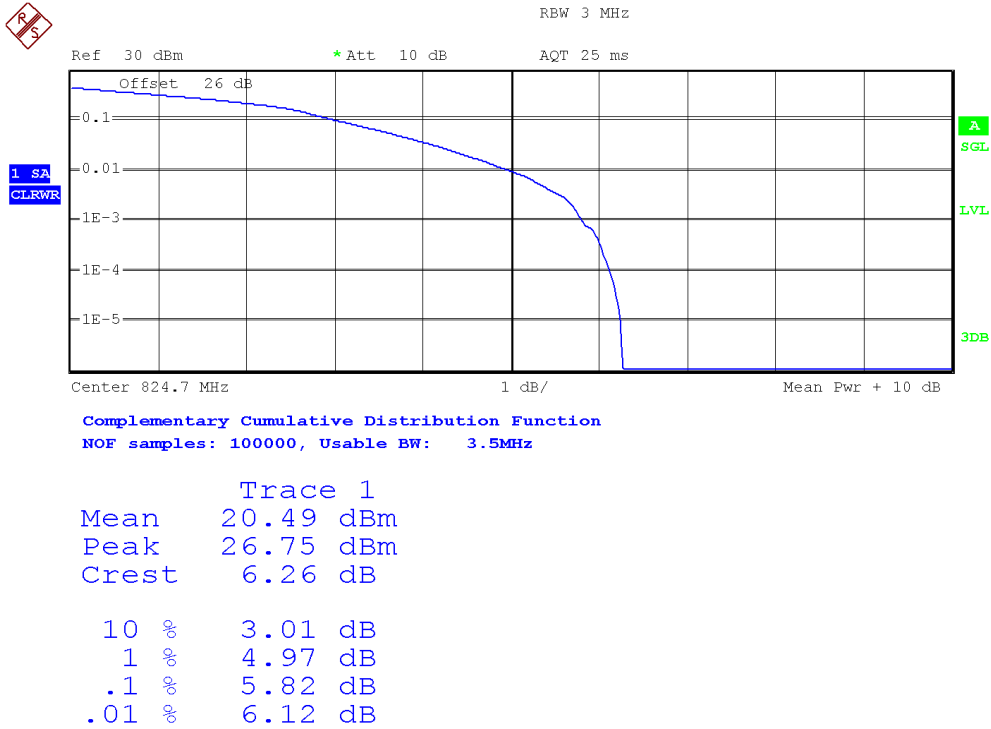

Middle Channel:

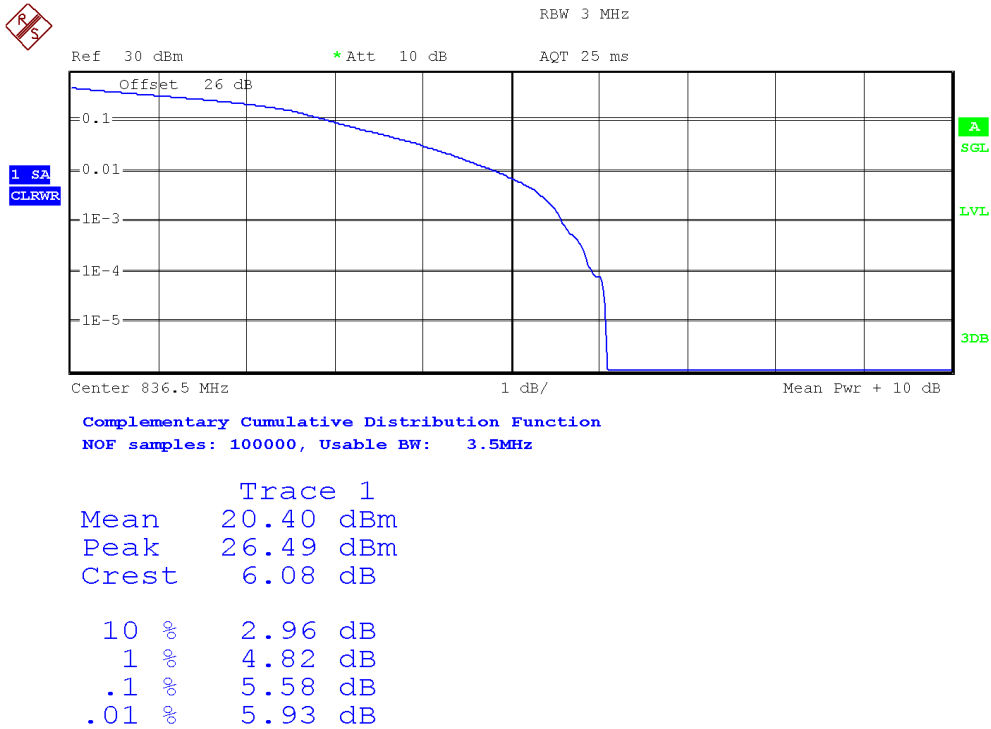

Highest Channel:

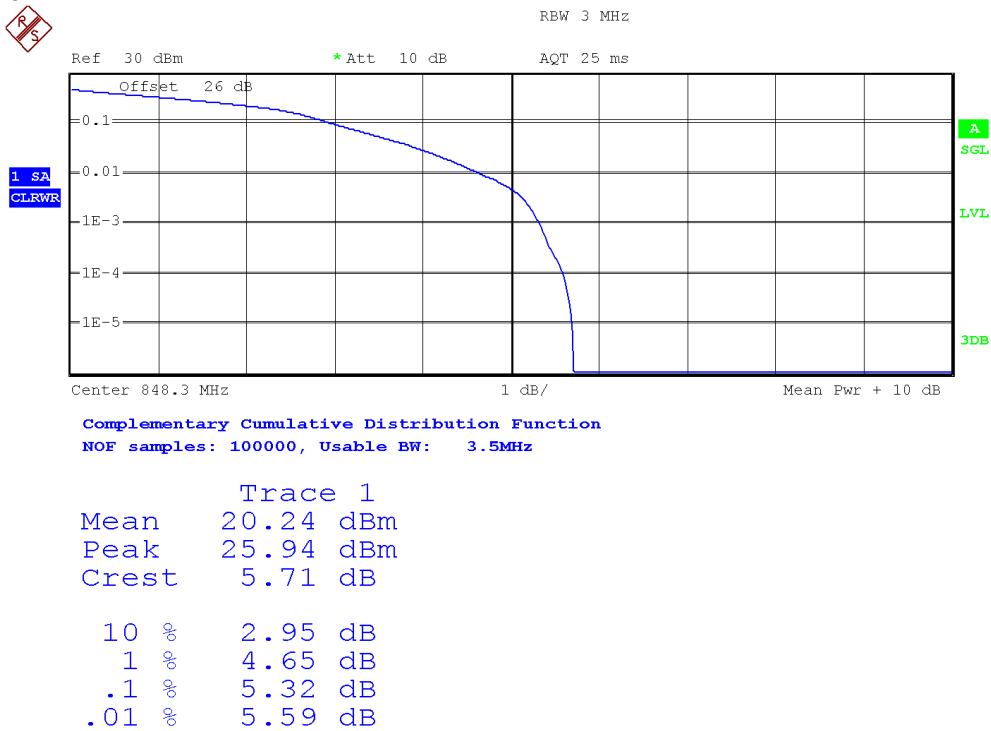

LTE Band 5. Bandwidth = 3 MHz. Modulation 16 QAM. RB Size: 15. RB Offset: 0.

Lowest Channel:

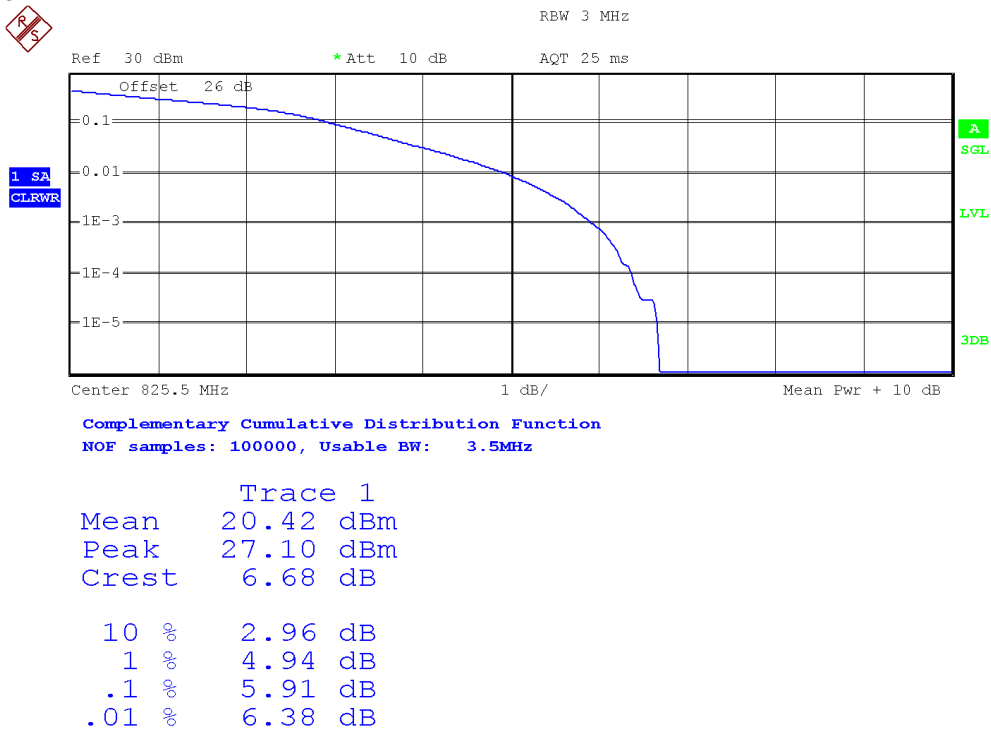

Middle Channel:

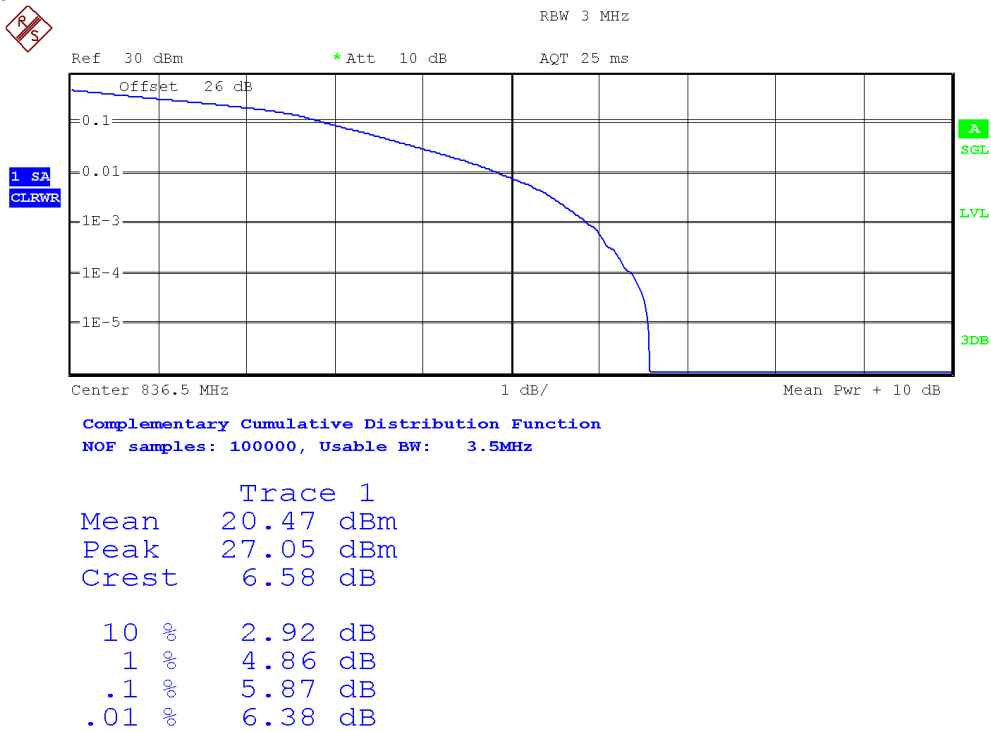

Highest Channel:

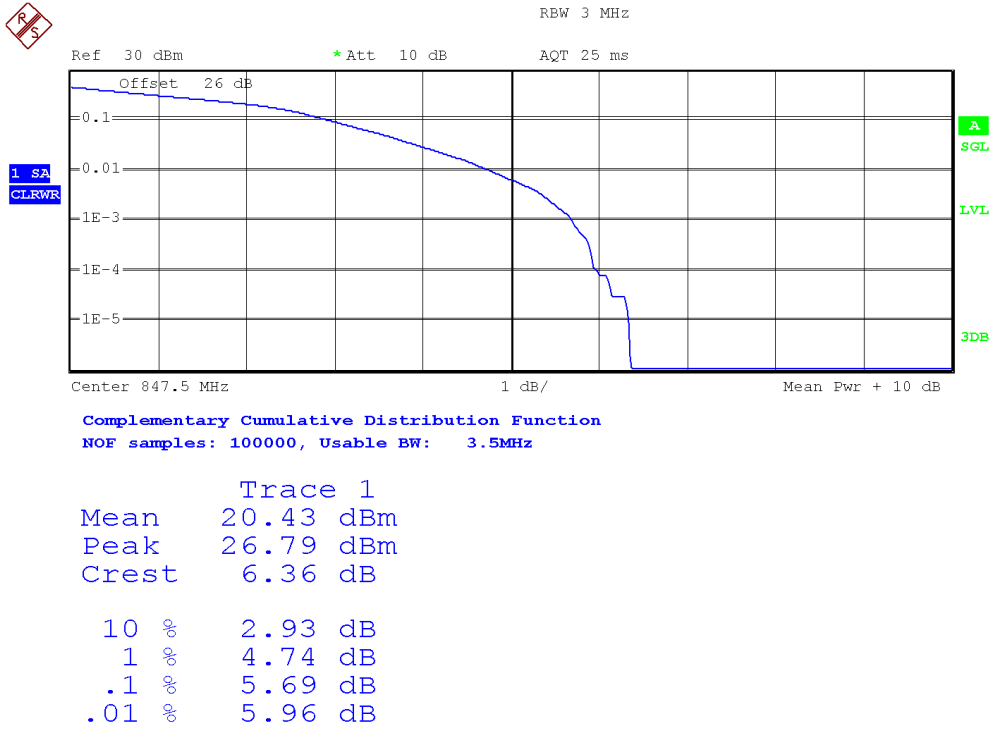

LTE Band 5. Bandwidth = 5 MHz. Modulation 16 QAM. RB Size: 25. RB Offset: 0.

Lowest Channel:

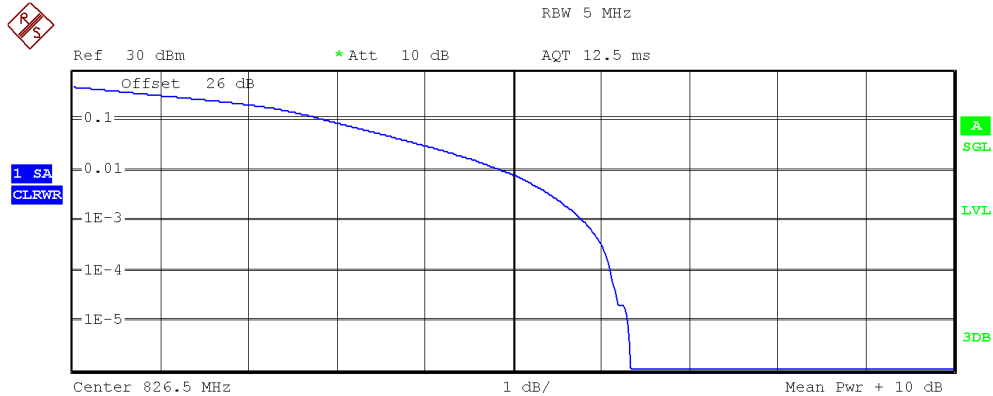

Complementary Cumulative Distribution Function
 NOF samples: 100000, Usable BW: 7.1MHz

Trace 1	
Mean	20.56 dBm
Peak	26.89 dBm
Crest	6.33 dB
10 %	2.87 dB
1 %	4.87 dB
.1 %	5.79 dB
.01 %	6.11 dB

Middle Channel:

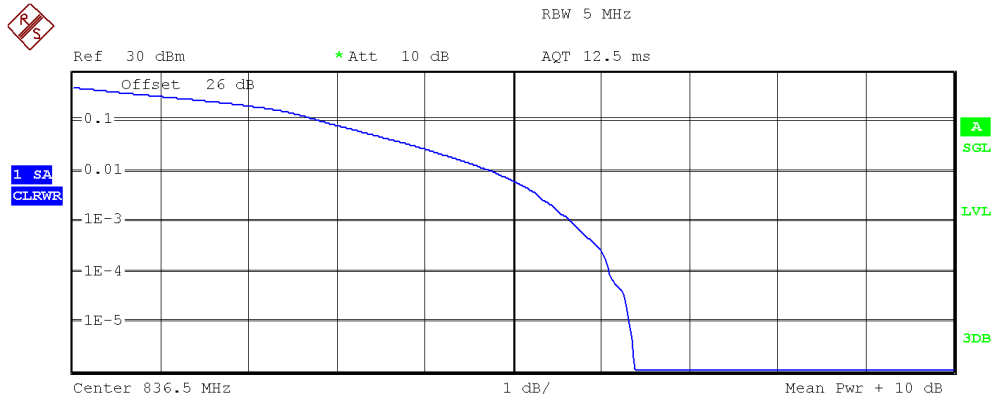

Complementary Cumulative Distribution Function
 NOF samples: 100000, Usable BW: 7.1MHz

Trace 1	
Mean	20.60 dBm
Peak	26.98 dBm
Crest	6.38 dB
10 %	2.84 dB
1 %	4.76 dB
.1 %	5.66 dB
.01 %	6.11 dB

Highest Channel:

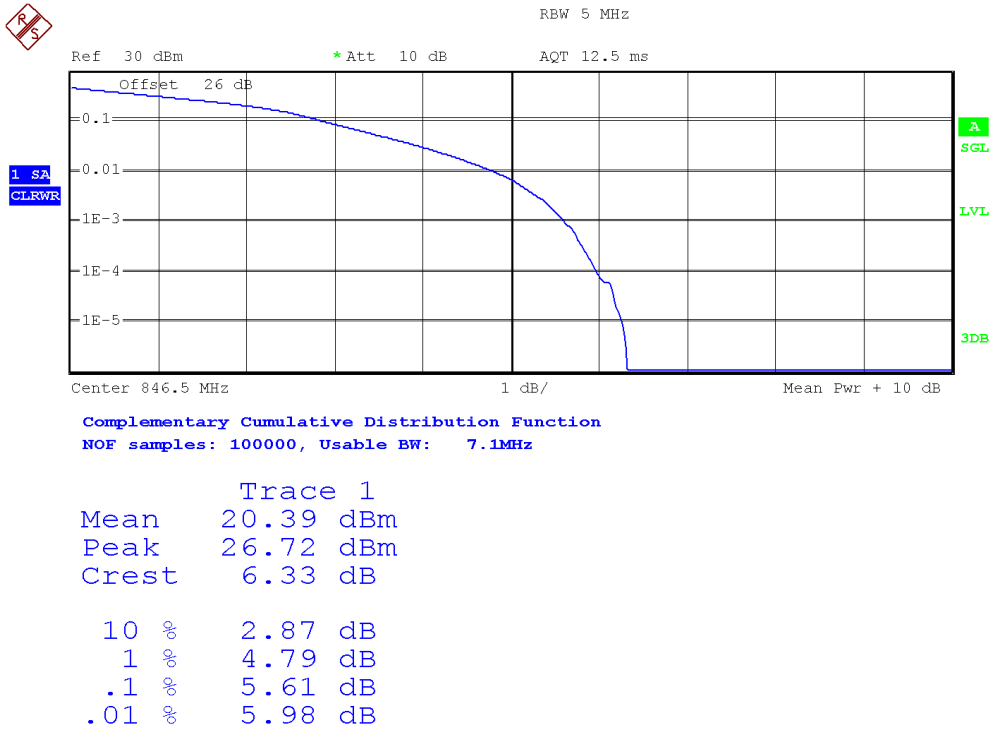

LTE Band 5. Bandwidth = 10 MHz. Modulation QPSK. RB Size: 50. RB Offset: 0.

Lowest Channel:

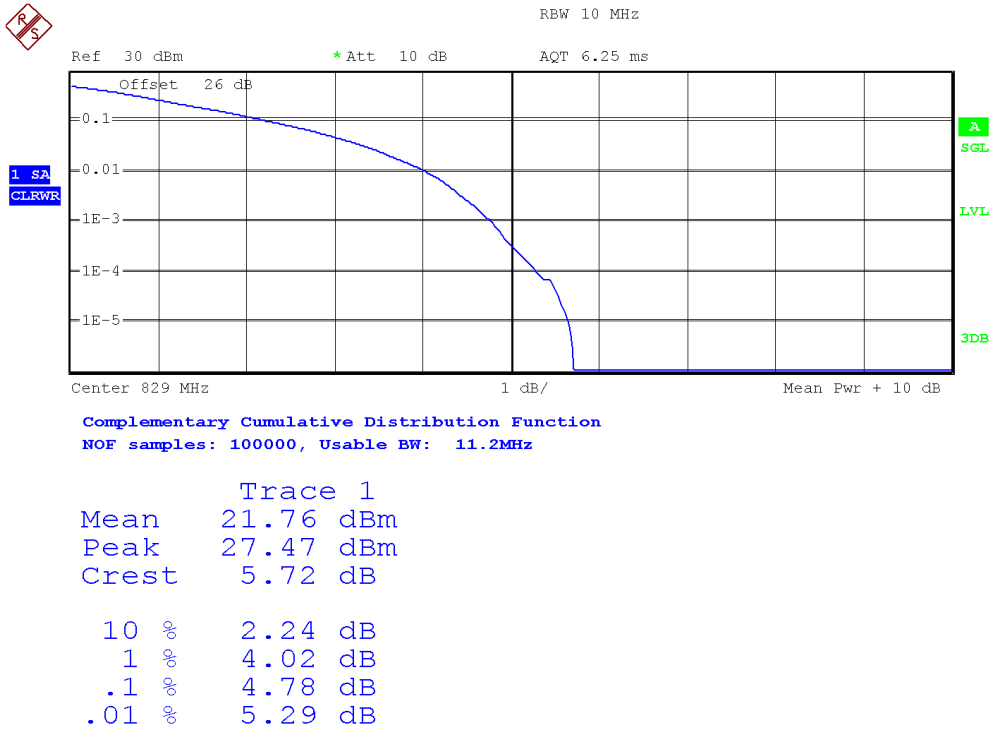

Middle Channel:

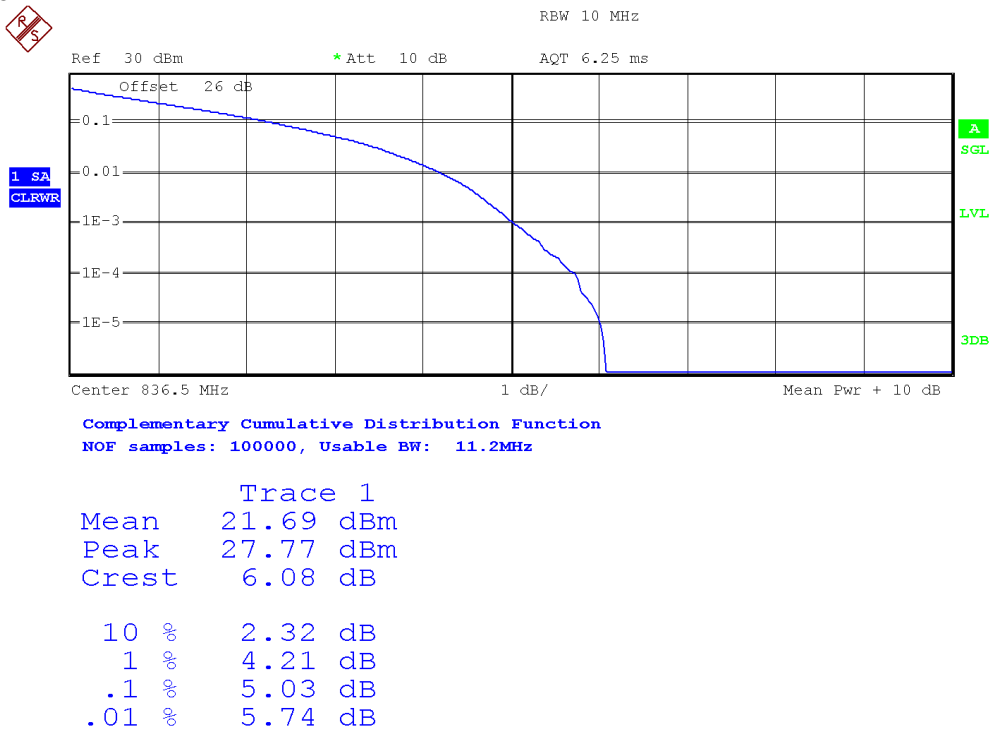

Highest Channel:

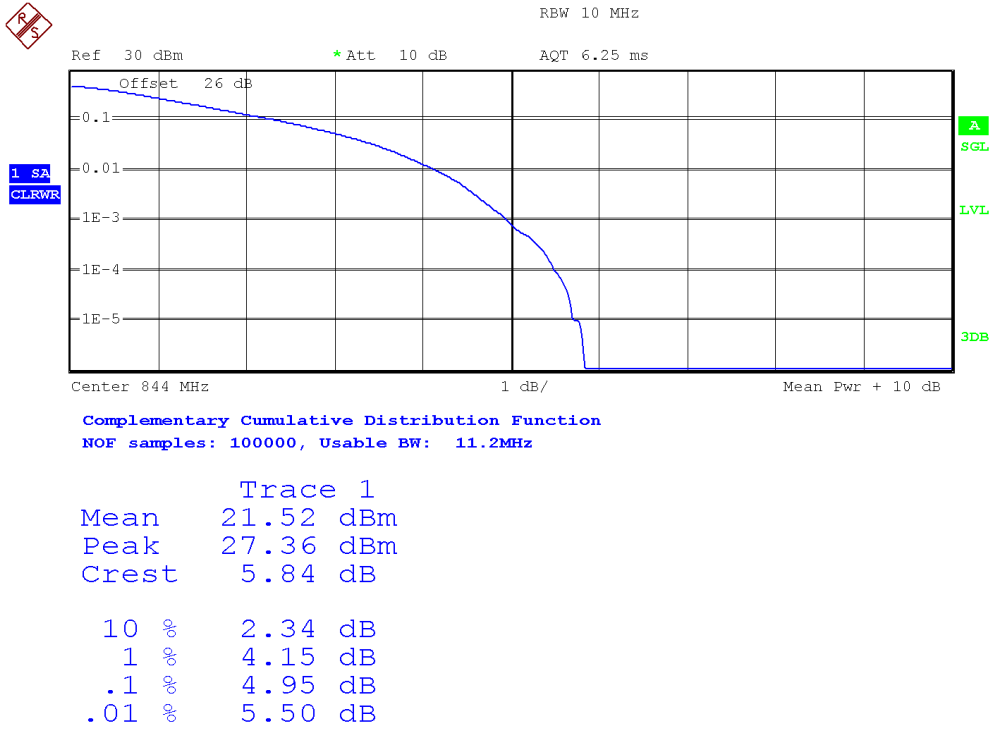

Frequency Stability

SPECIFICATION:

FCC §2.1055 and §22.355. ± 2.5 ppm for mobile stations operating in the range 821 to 896 MHz.

RSS-132. Clause 5.3. The carrier frequency shall not depart from the reference frequency in excess of ± 2.5 ppm for mobile stations.

METHOD:

The frequency tolerance measurements over temperature variations were made over the temperature range of -30°C to $+50^{\circ}\text{C}$. The EUT was placed inside a climatic chamber and the temperature was raised hourly in 10°C steps from -30°C up to $+50^{\circ}\text{C}$.

The supply voltage was varied between 85% and 115% of nominal voltage.

The EUT was set in "Radio Resource Control (RRC) mode" in the middle channel using the Universal Radio Communication tester R&S CMW500 and the maximum frequency error was measured using the built-in calibrated frequency meter.

The reference point measurements were made at the RF output terminals of the EUT using an attenuator, power splitter and spectrum analyser. The EUT was controlled via the Universal Radio Communication tester R&S CMW500 selecting maximum transmission power of the EUT and different modes of modulation.

TEST SETUP:

1. Frequency Tolerance:

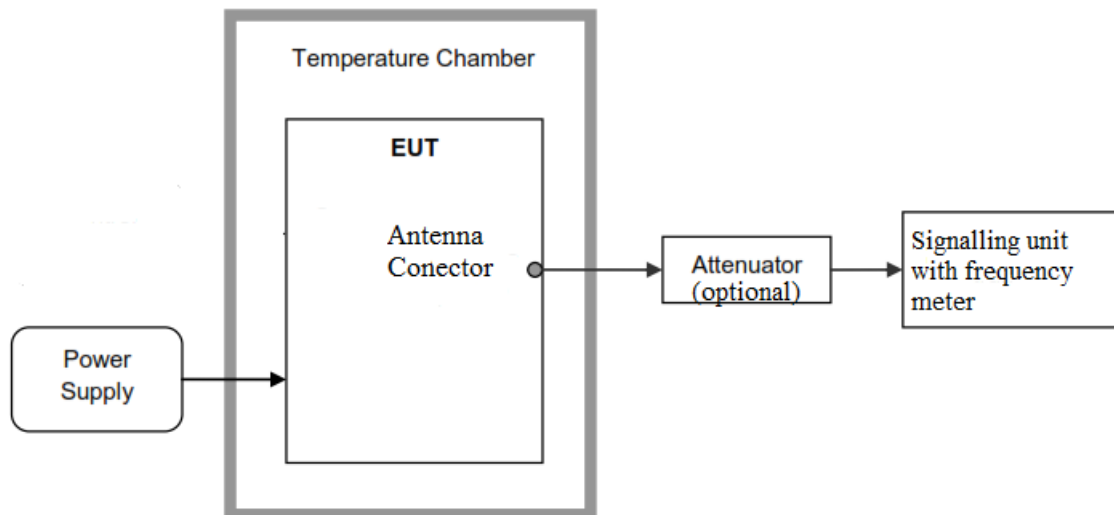

RESULTS:

1. Frequency Tolerance:

• **Frequency Stability over Temperature Variations:**

3G Band V. WCDMA AND HSUPA MODULATIONS.

Temperature (°C)	Frequency Error (Hz)	Frequency Error (ppm)
+50	-0.07	-0.000084
+40	0.15	0.000179
+30	-1.64	-0.001960
+20	0.11	0.000131
+10	-1.78	-0.002128
0	-1.89	-0.002259
-10	-0.03	-0.000036
-20	0.54	0.000645
-30	1.41	0.001685

LTE Band 5. QPSK MODULATION. BW = 10 MHz.

Temperature (°C)	Frequency Error (Hz)	Frequency Error (ppm)
+50	-0.86	-0.001028
+40	-0.79	-0.000944
+30	-0.66	-0.000789
+20	-0.53	-0.000633
+10	-0.16	-0.000191
0	0.62	0.000741
-10	0.5	0.000597
-20	0.5	0.000597
-30	0.33	0.000394

• **Frequency Stability over Voltage Variations.**

3G Band V. WCDMA AND HSUPA MODULATIONS.

Battery Supply voltage	Voltage (V)	Frequency Error (Hz)	Frequency Error (ppm)
Vmax	15	-0.05	-0.000060
Vmin (*)	9	-0.08	-0.000096

(*): Operating end point specified by the manufacturer.

LTE Band 5. QPSK MODULATION. BW = 10 MHz.

Battery Supply voltage	Voltage (V)	Frequency Error (Hz)	Frequency Error (ppm)
Vmax	15	-0.43	-0.000514
Vmin (*)	9	-0.57	-0.000681

(*): Operating end point specified by the manufacturer.

Verdict: PASS

Modulation Characteristics

SPECIFICATION:

FCC §2.1047.

RSS-132. Clause 5.2: Equipment certified under this standard shall use digital modulation.

METHOD:

For 3G, the EUT operates with WCDMA (QPSK) and HSUPA (QPSK) modes, in which the information is digitized and coded into a bit stream.

For LTE the EUT operates with QPSK and 16QAM modulation modes in which the information is digitized and coded into a bit stream. The RF transmission is multiplexed using *Orthogonal Frequency Division Multiplexing (OFDM)* using different possible arrangement of subcarriers (Resource Blocks RB).

TEST SETUP:

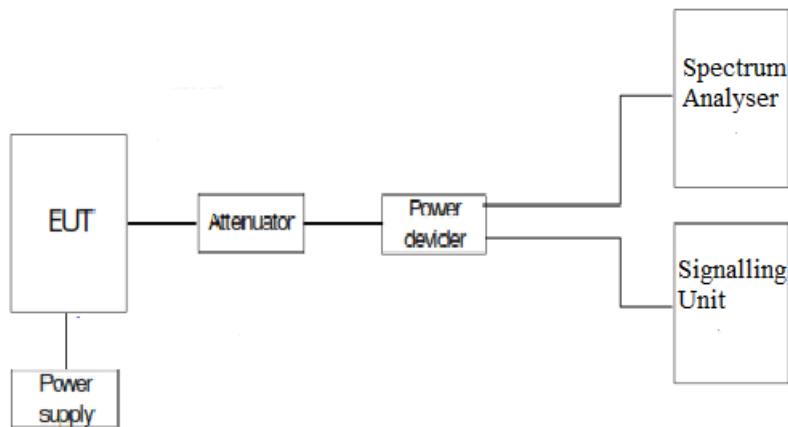

RESULTS:

The following plots show the modulation schemes in the EUT.

3G Band V. WCDMA MODULATION.

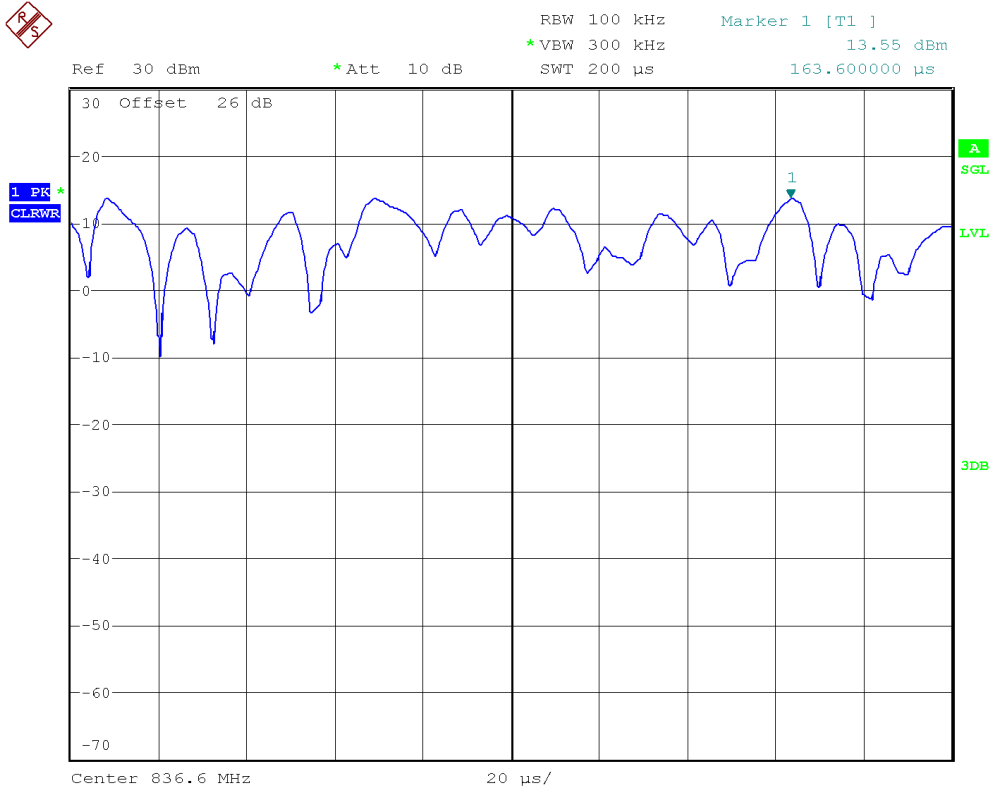

3G Band V. HSUPA MODULATION.

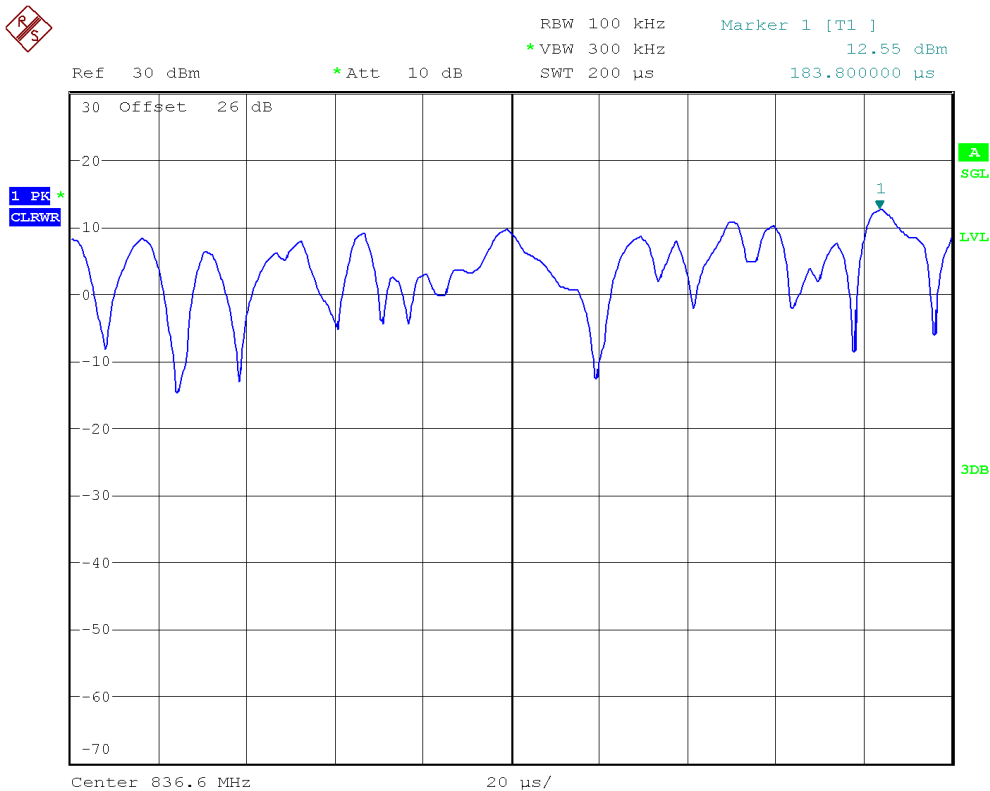

LTE Band 5. QPSK MODULATION. BW = 3 MHz.

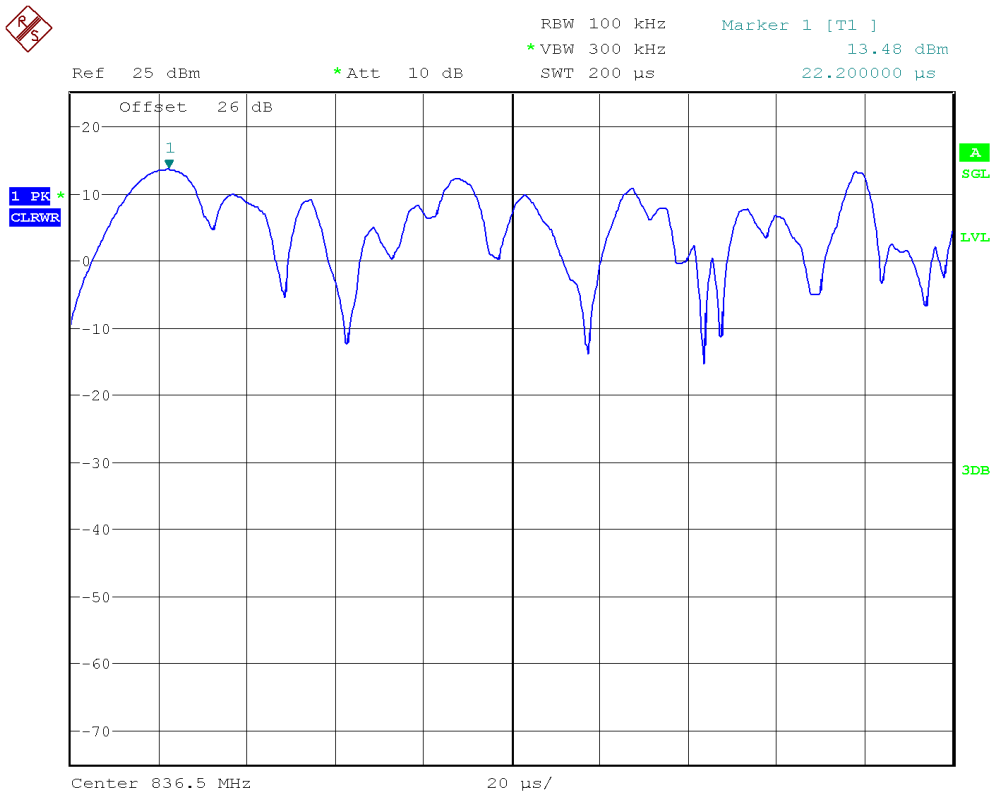

LTE Band 5. 16QAM MODULATION. BW = 3 MHz.

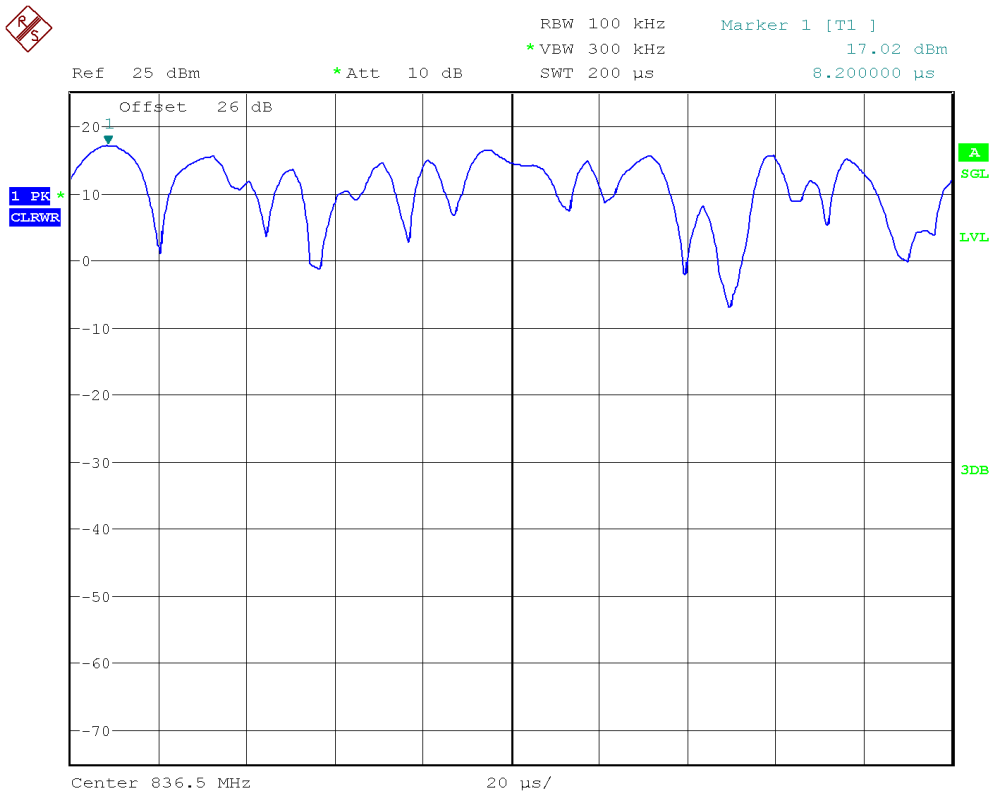

Occupied Bandwidth

SPECIFICATION:

FCC §2.1049.

METHOD:

The occupied bandwidth measurement was performed at the output terminals of the EUT using an attenuator, power splitter and spectrum analyser. The EUT was controlled via the Universal Radio Communication tester R&S CMW500 selecting maximum transmission power of the EUT and different modes of modulation. The 99% occupied bandwidth and the -26 dBc bandwidth were measured directly using the built-in bandwidth measuring option of spectrum analyser.

TEST SETUP:

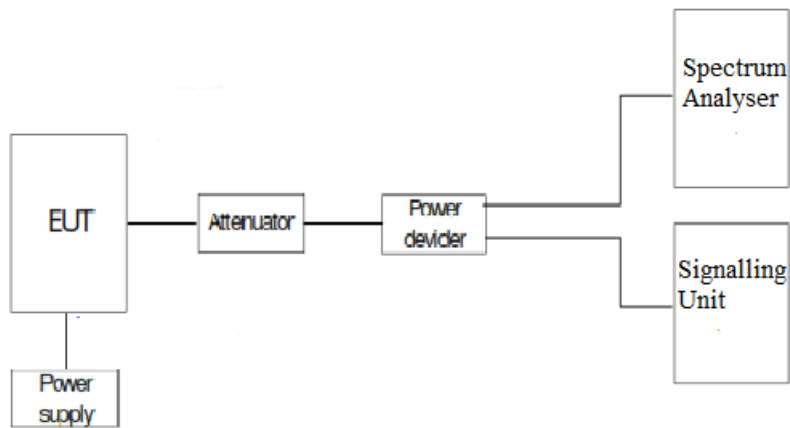

RESULTS:

3G Band V:

3G Band V. WCDMA MODULATION.

	Lowest Channel	Middle Channel	Highest Channel
99% Occupied bandwidth (kHz)	4130.00	4140.00	4130.00
-26 dBc bandwidth (kHz)	4711.54	4743.59	4727.56
Measurement uncertainty (kHz)	<±16.67		

3G Band V. HSUPA MODULATION.

	Lowest Channel	Middle Channel	Highest Channel
99% Occupied bandwidth (kHz)	4130.00	4150.00	4130.00
-26 dBc bandwidth (kHz)	4714.87	4743.59	4711.54
Measurement uncertainty (kHz)	<±16.67		

LTE Bands: The worst case of Occupied Bandwidth corresponds to all Resource Blocks (RB) with Offset 0, regardless the nominal bandwidth selected.

LTE Band 5:

LTE Band 5. QPSK MODULATION. BW = 1.4 MHz.

	Lowest Channel	Middle Channel	Highest Channel
99% Occupied bandwidth (kHz)	1094.80	1103.20	1114.40
-26 dBc bandwidth (kHz)	1304.80	1338.40	1332.20
Measurement uncertainty (kHz)	<±4.67		

LTE Band 5. 16QAM MODULATION. BW = 1.4 MHz.

	Lowest Channel	Middle Channel	Highest Channel
99% Occupied bandwidth (kHz)	1097.60	1106.00	1097.60
-26 dBc bandwidth (kHz)	1310.40	1335.60	1318.20
Measurement uncertainty (kHz)	<±4.67		

LTE Band 5. QPSK MODULATION. BW = 3 MHz.

	Lowest Channel	Middle Channel	Highest Channel
99% Occupied bandwidth (kHz)	2736.00	2736.00	2736.00
-26 dBc bandwidth (kHz)	3066.00	3090.00	3070.00
Measurement uncertainty (kHz)	<±10		

LTE Band 5. 16QAM MODULATION. BW = 3 MHz.

	Lowest Channel	Middle Channel	Highest Channel
99% Occupied bandwidth (kHz)	2730.00	2742.00	2742.00
-26 dBc bandwidth (kHz)	3078.00	3090.00	3072.00
Measurement uncertainty (kHz)	<±10		

LTE Band 5. QPSK MODULATION. BW = 5 MHz.

	Lowest Channel	Middle Channel	Highest Channel
99% Occupied bandwidth (kHz)	4510.00	4550.00	4510.00
-26 dBc bandwidth (kHz)	4940.00	5080.00	4990.00
Measurement uncertainty (kHz)	<±16.67		

LTE Band 5. 16QAM MODULATION. BW = 5 MHz.

	Lowest Channel	Middle Channel	Highest Channel
99% Occupied bandwidth (kHz)	4500.00	4520.00	4500.00
-26 dBc bandwidth (kHz)	4980.00	5070.00	5020.00
Measurement uncertainty (kHz)	<±16.67		

LTE Band 5. QPSK MODULATION. BW = 10 MHz.

	Lowest Channel	Middle Channel	Highest Channel
99% Occupied bandwidth (kHz)	8900.00	8960.00	8940.00
-26 dBc bandwidth (kHz)	9730.00	9860.00	9680.00
Measurement uncertainty (kHz)	<±33.33		

3G Band V. WCDMA MODULATION.

Lowest Channel:

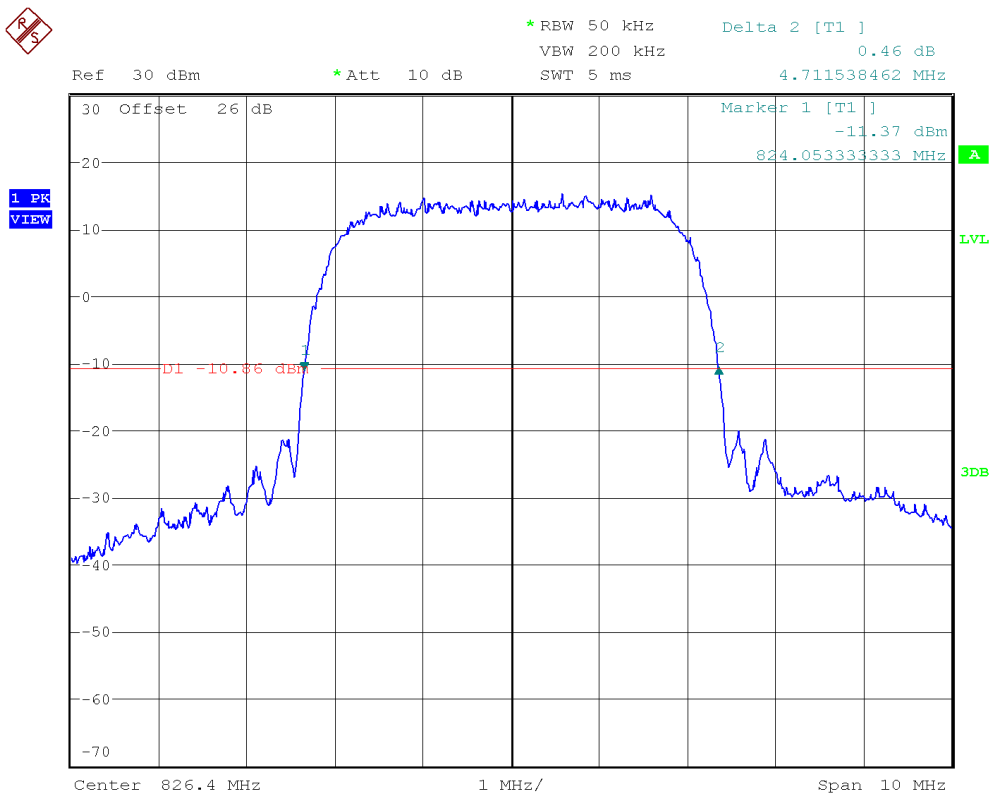
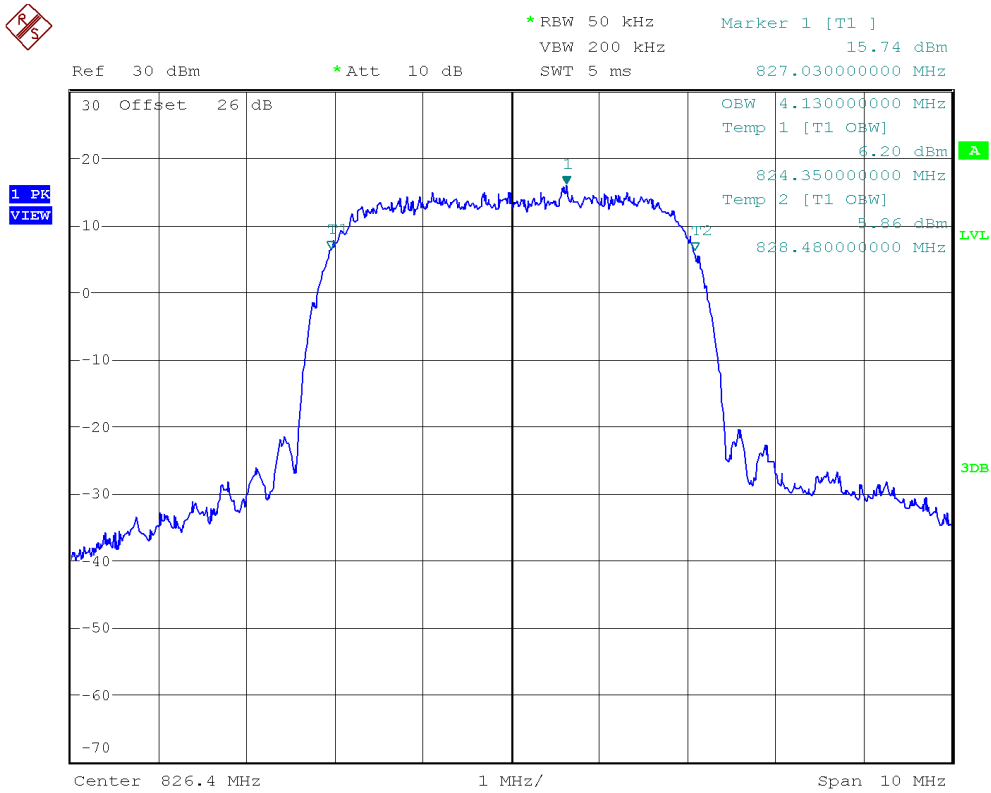

Middle Channel:

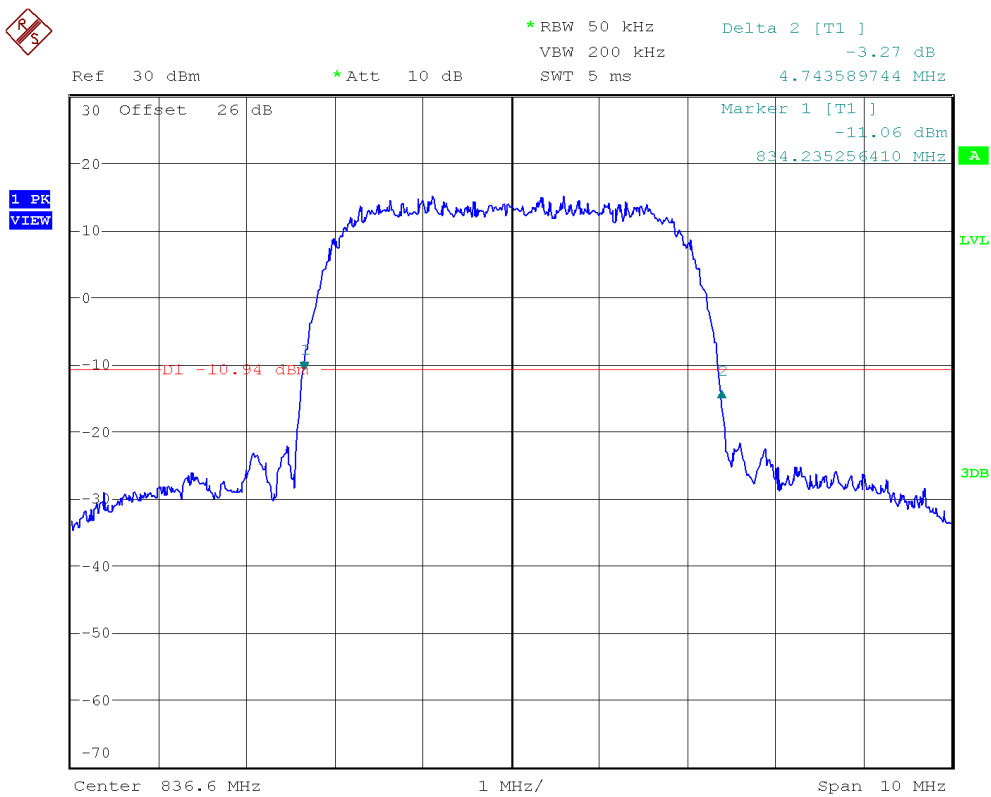
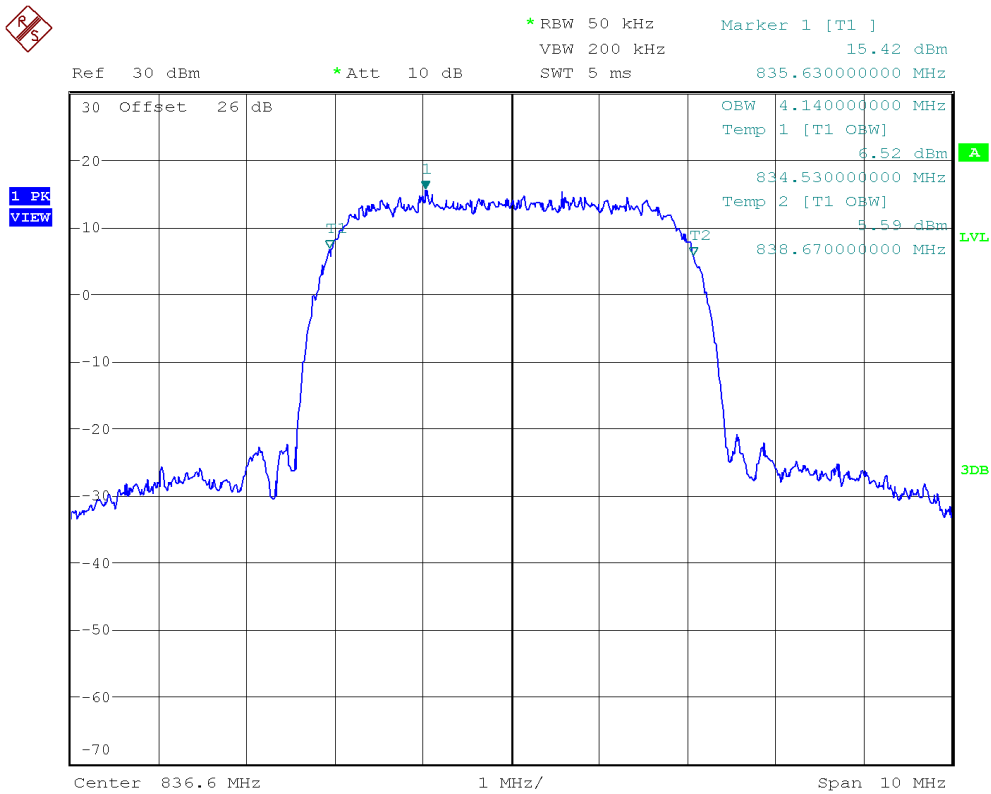

Highest Channel:

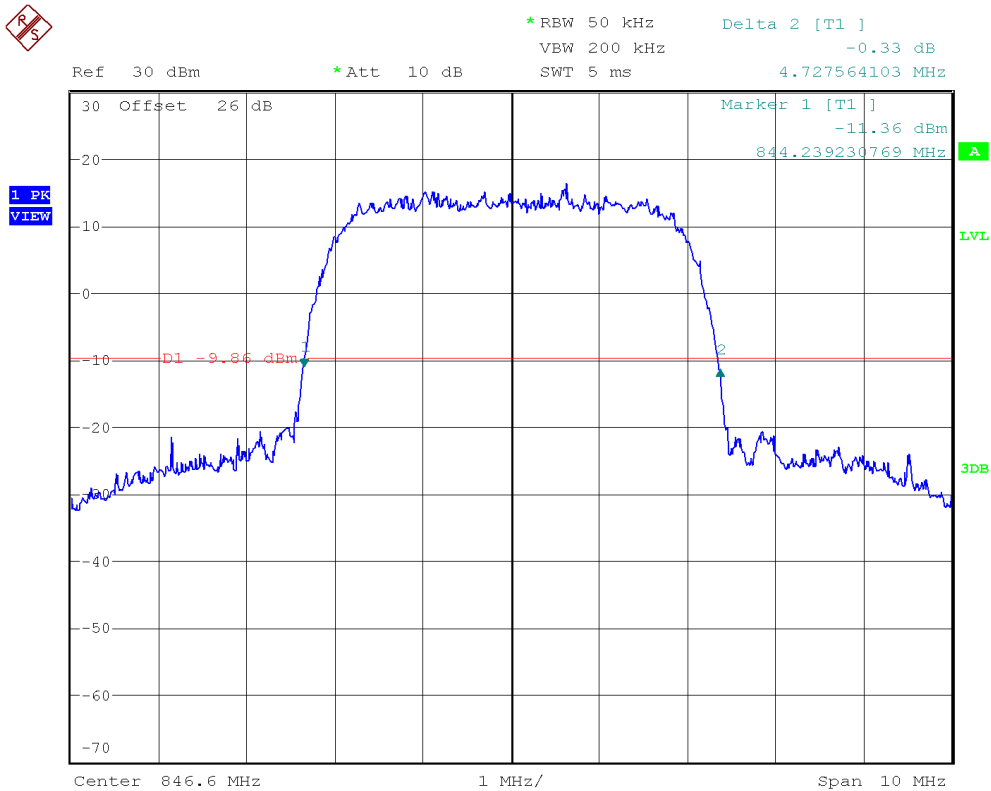
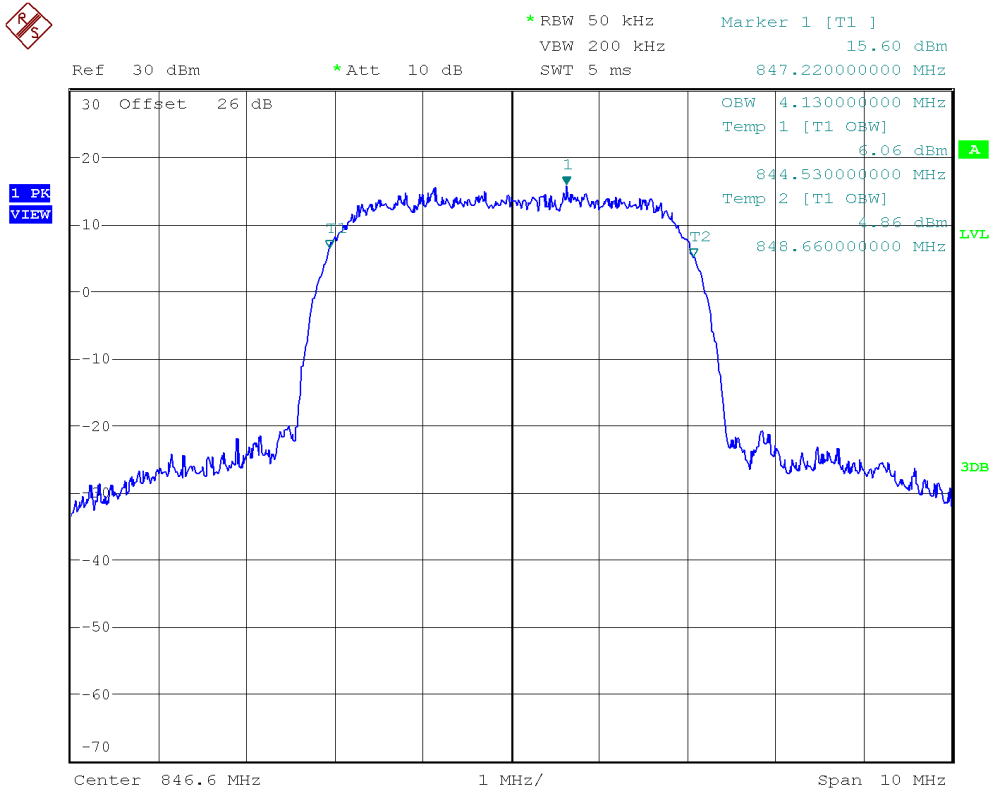

3G Band V. HSUPA MODULATION.

Lowest Channel:

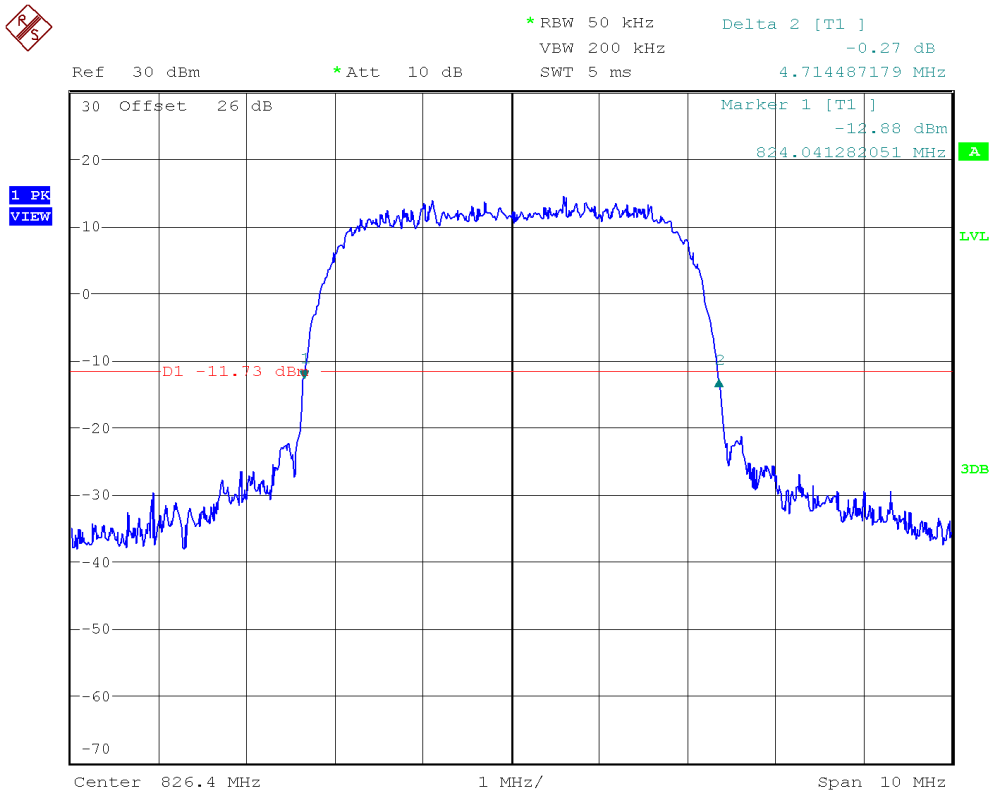
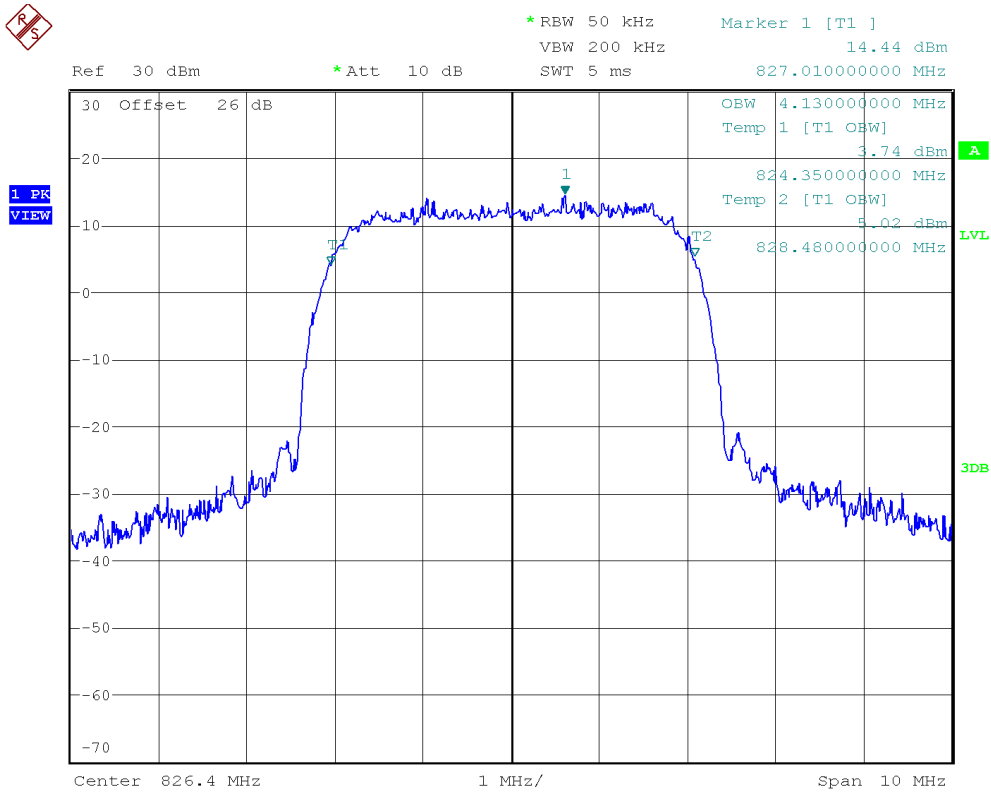

Middle Channel:

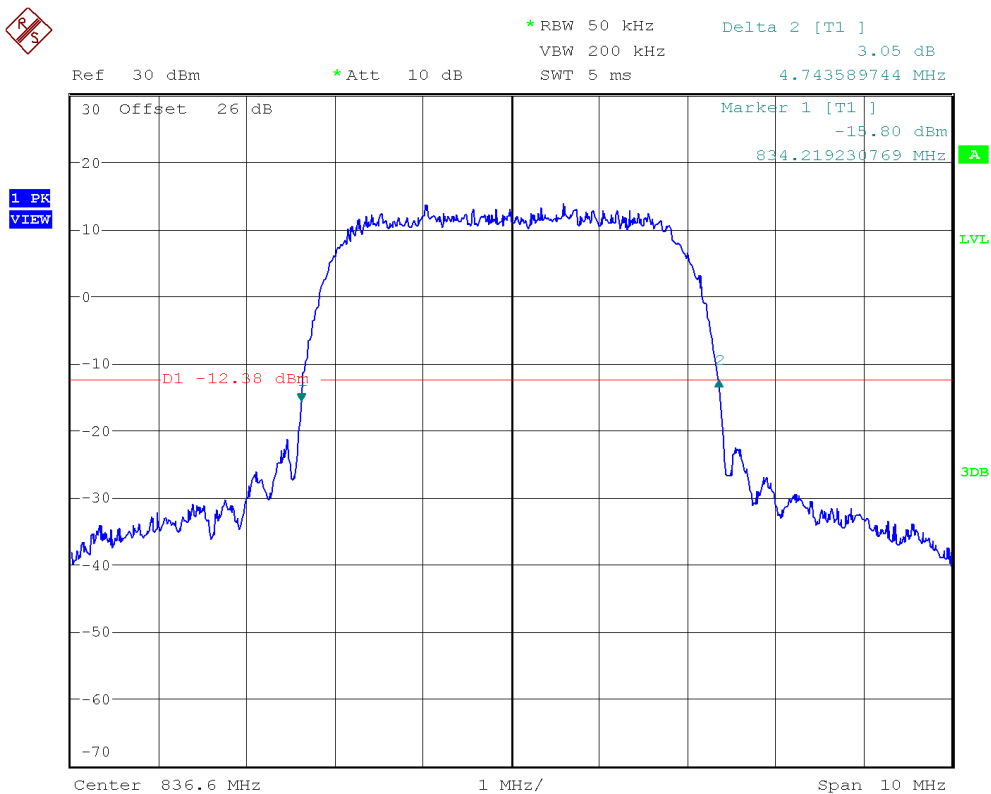
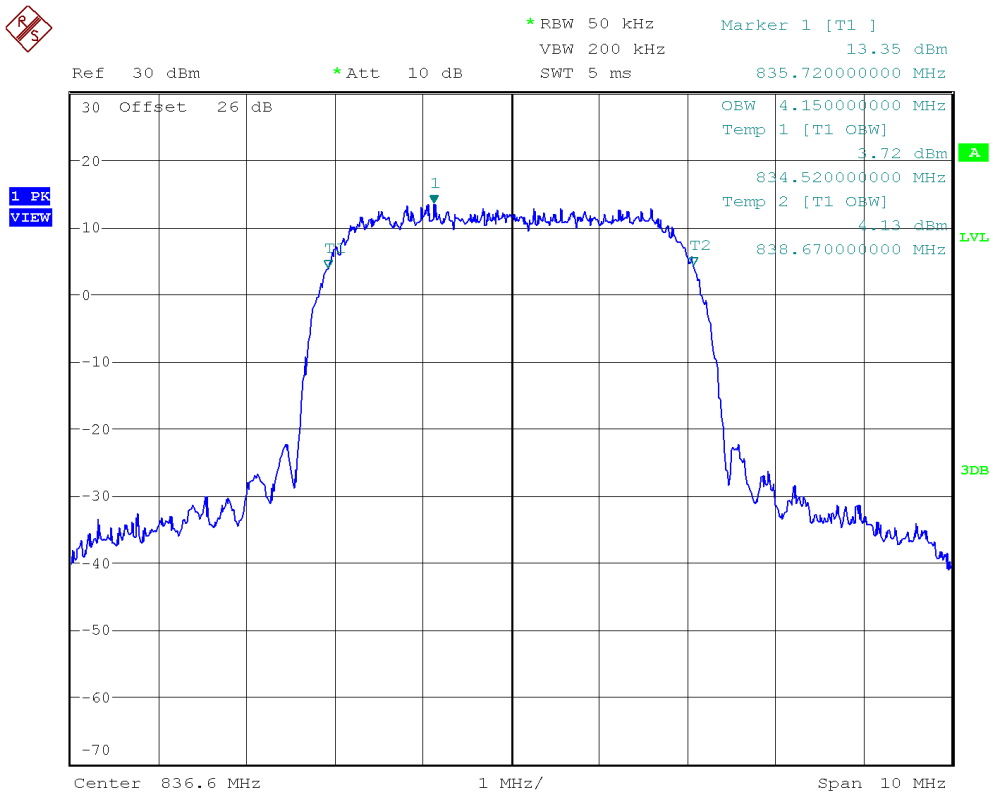

LTE Band 5. QPSK MODULATION. BW = 1.4 MHz.

Lowest Channel:

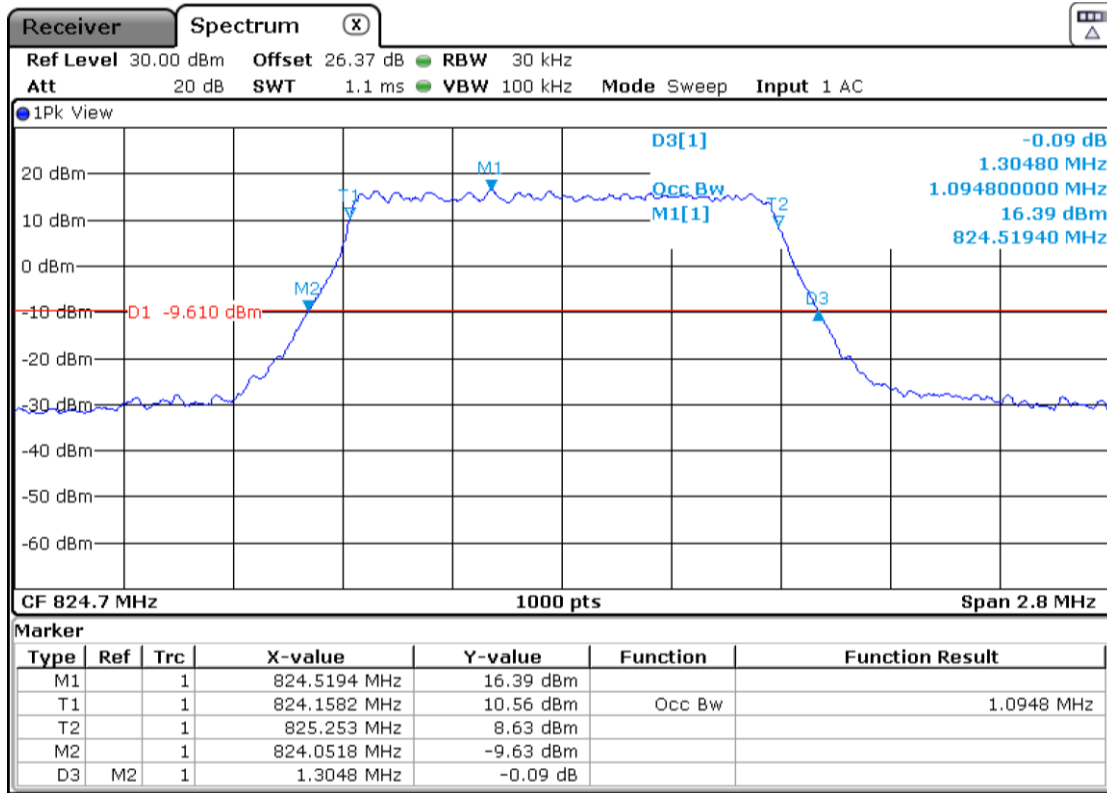

Middle Channel:

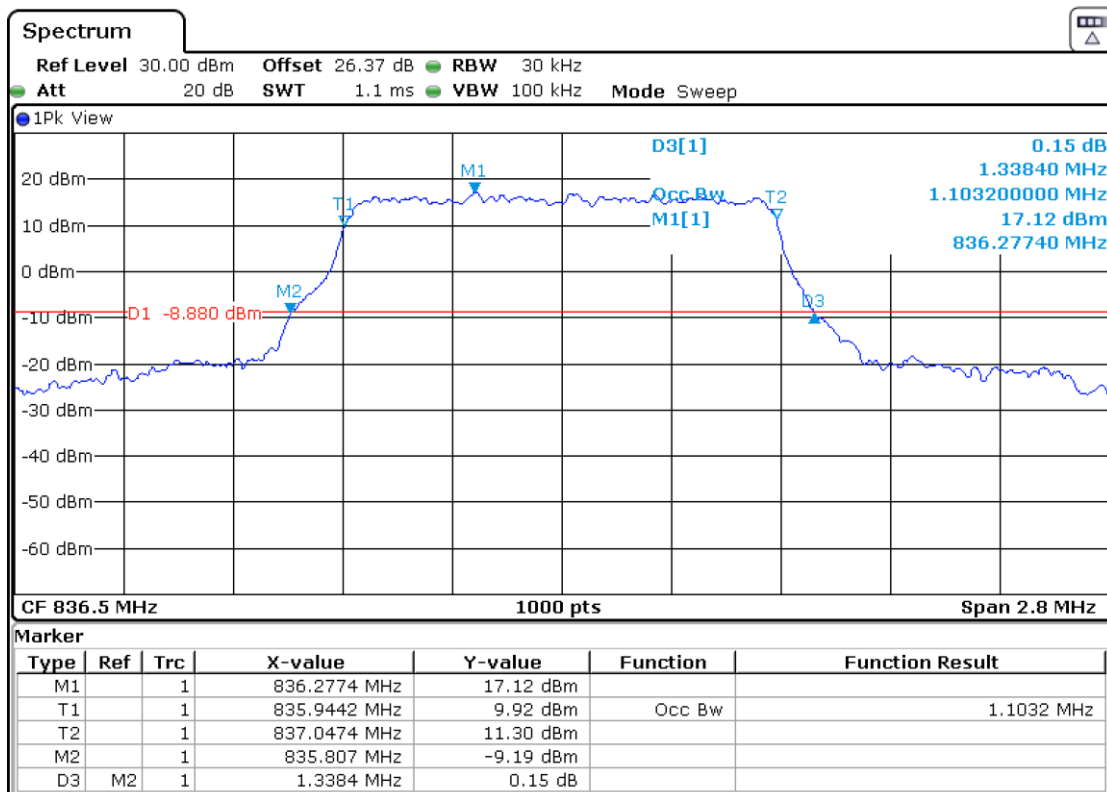

Highest Channel:

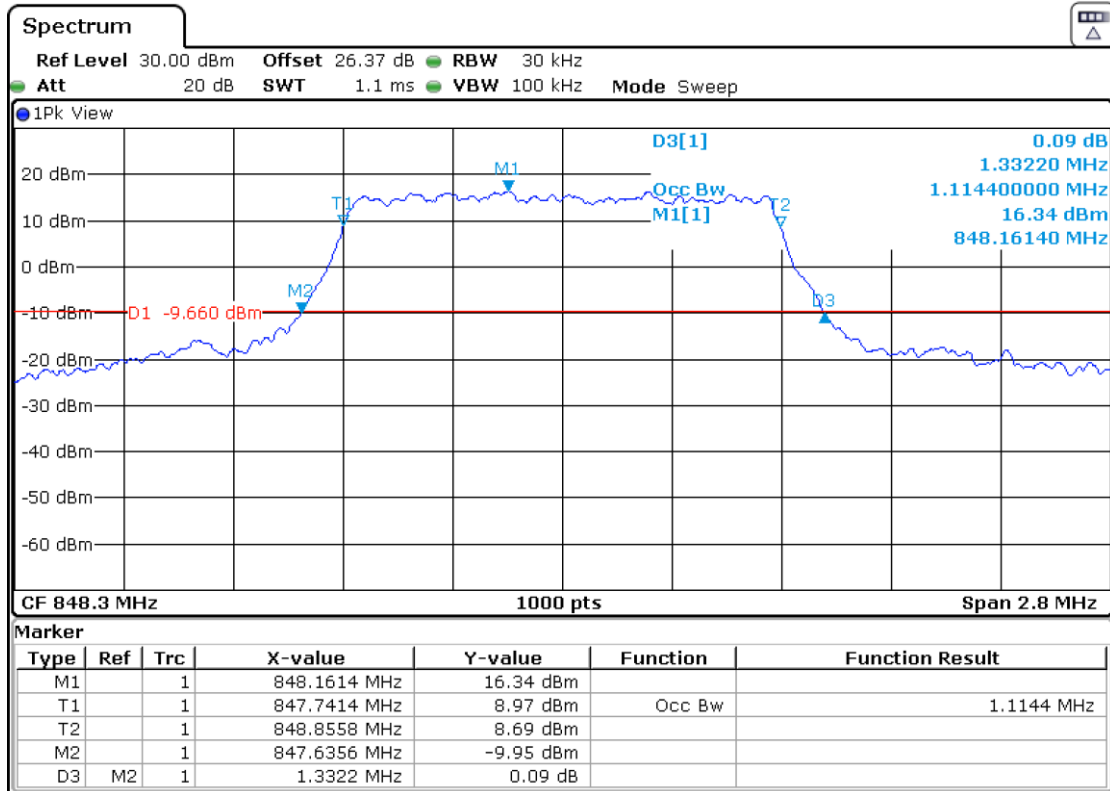

LTE Band 5. 16QAM MODULATION. BW = 1.4 MHz.

Lowest Channel:

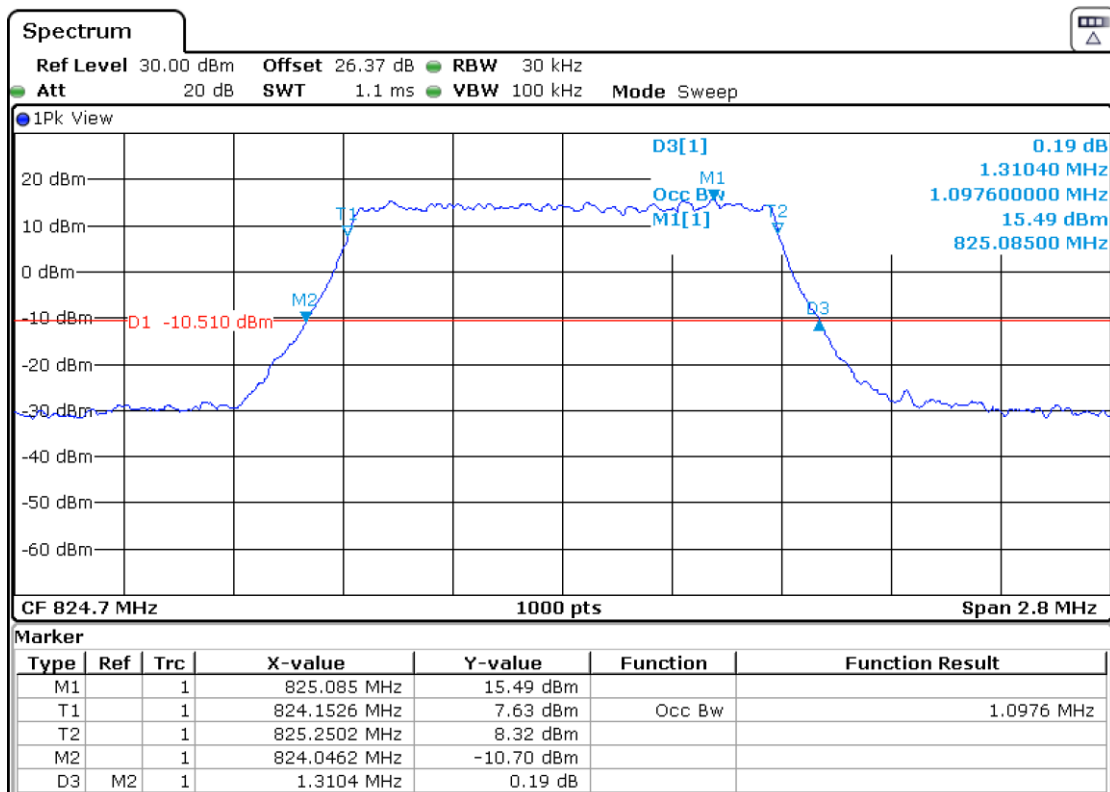

Middle Channel:

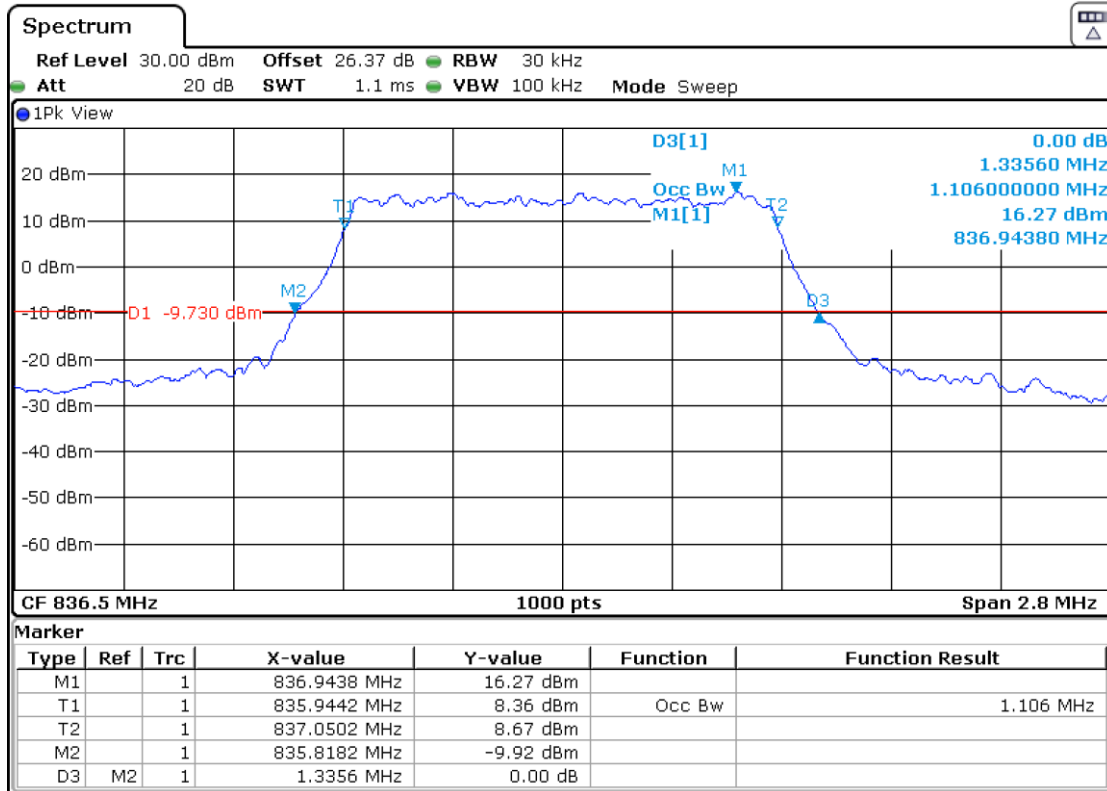

Highest Channel:

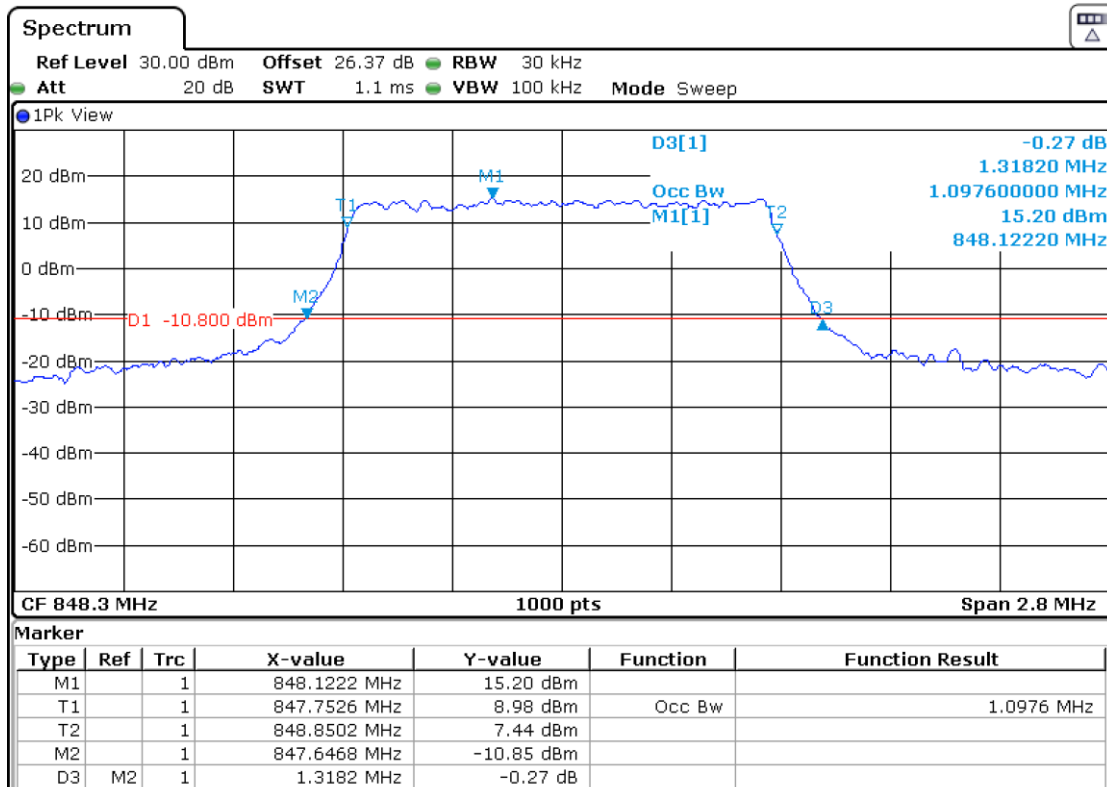

LTE Band 5. QPSK MODULATION. BW = 3 MHz.

Lowest Channel:

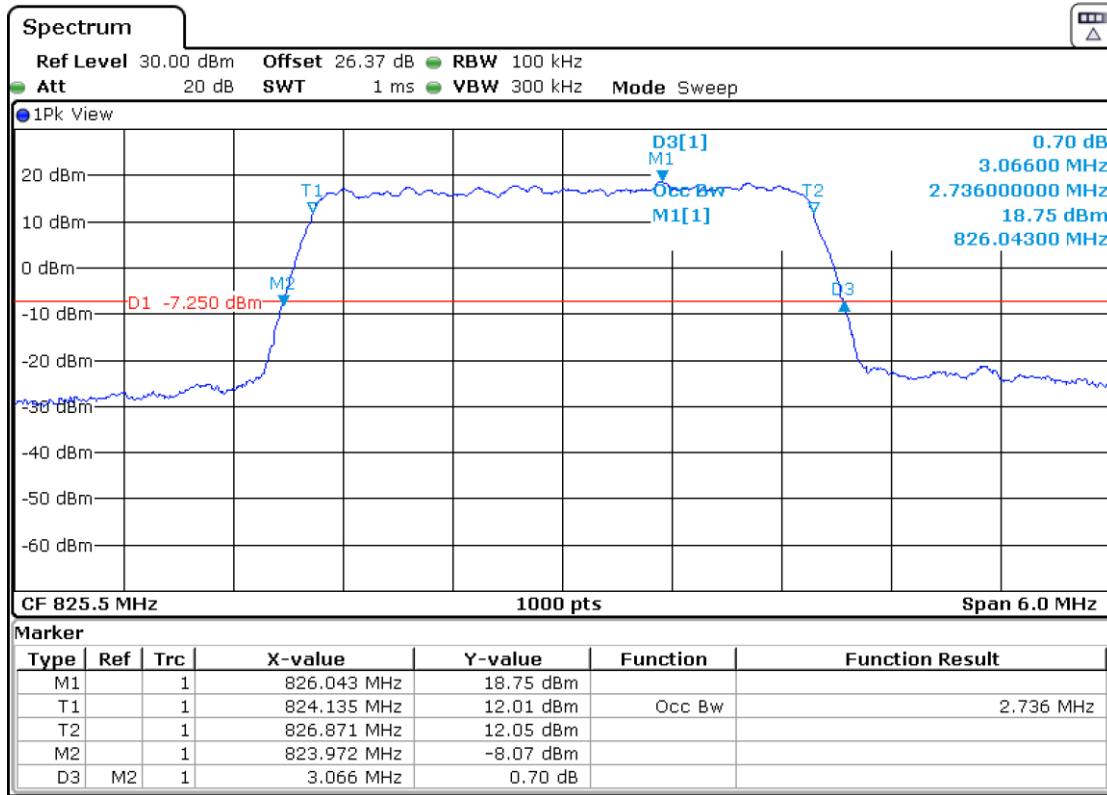

Middle Channel:

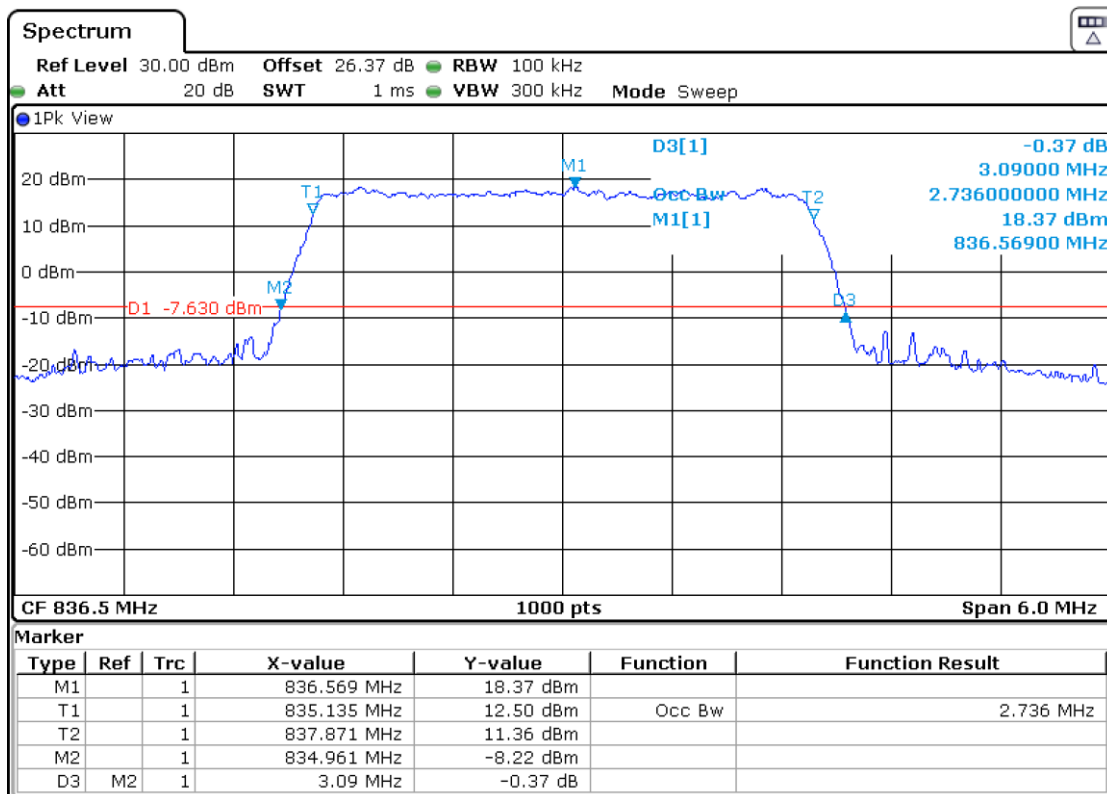

Highest Channel:

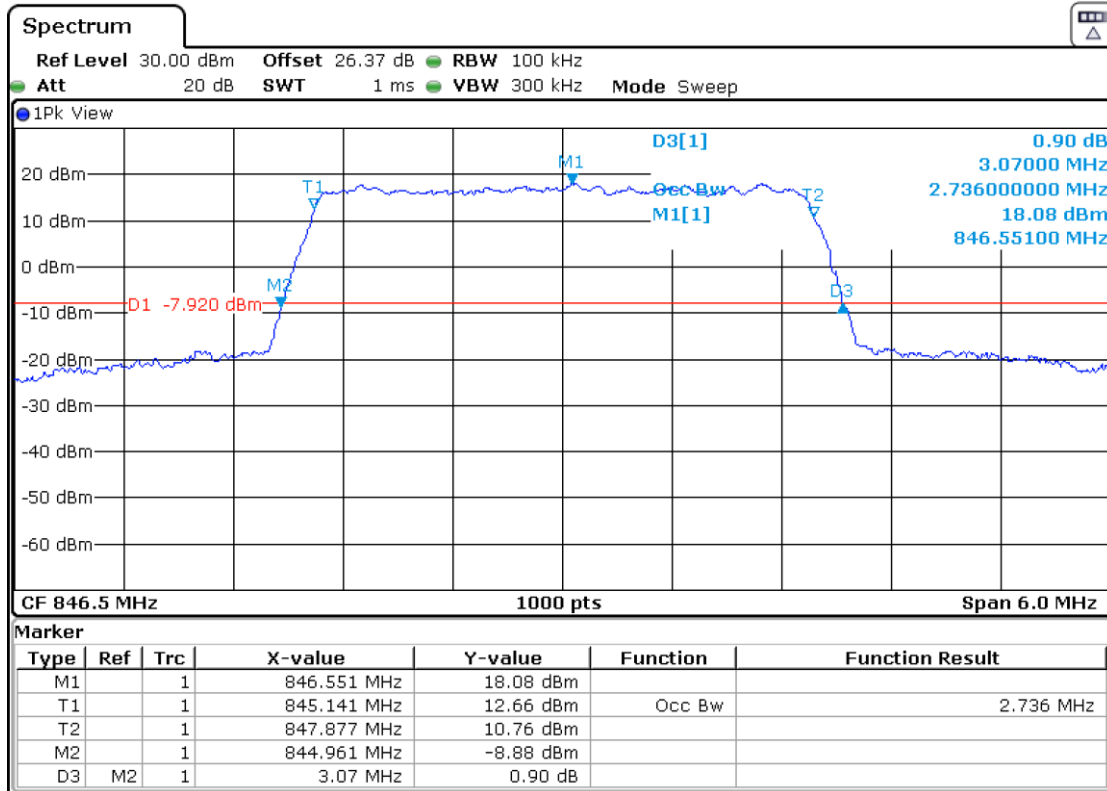

LTE Band 5. 16QAM MODULATION. BW = 3 MHz.

Lowest Channel:

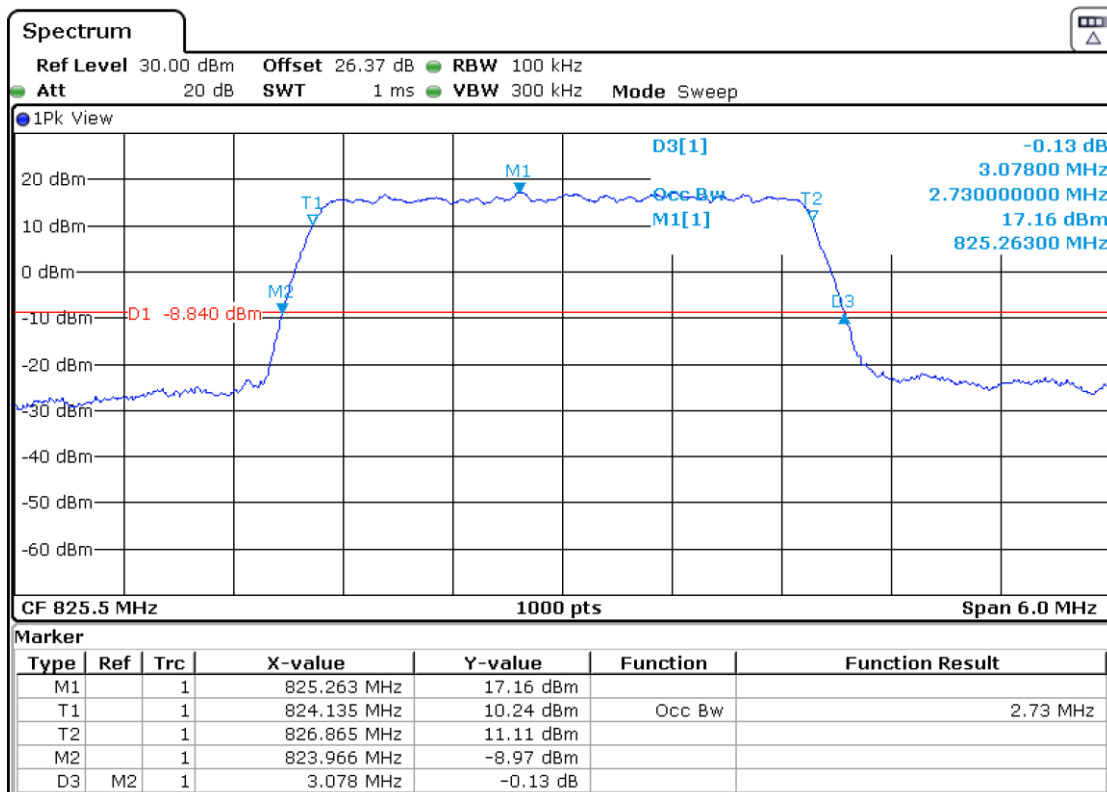

Middle Channel:

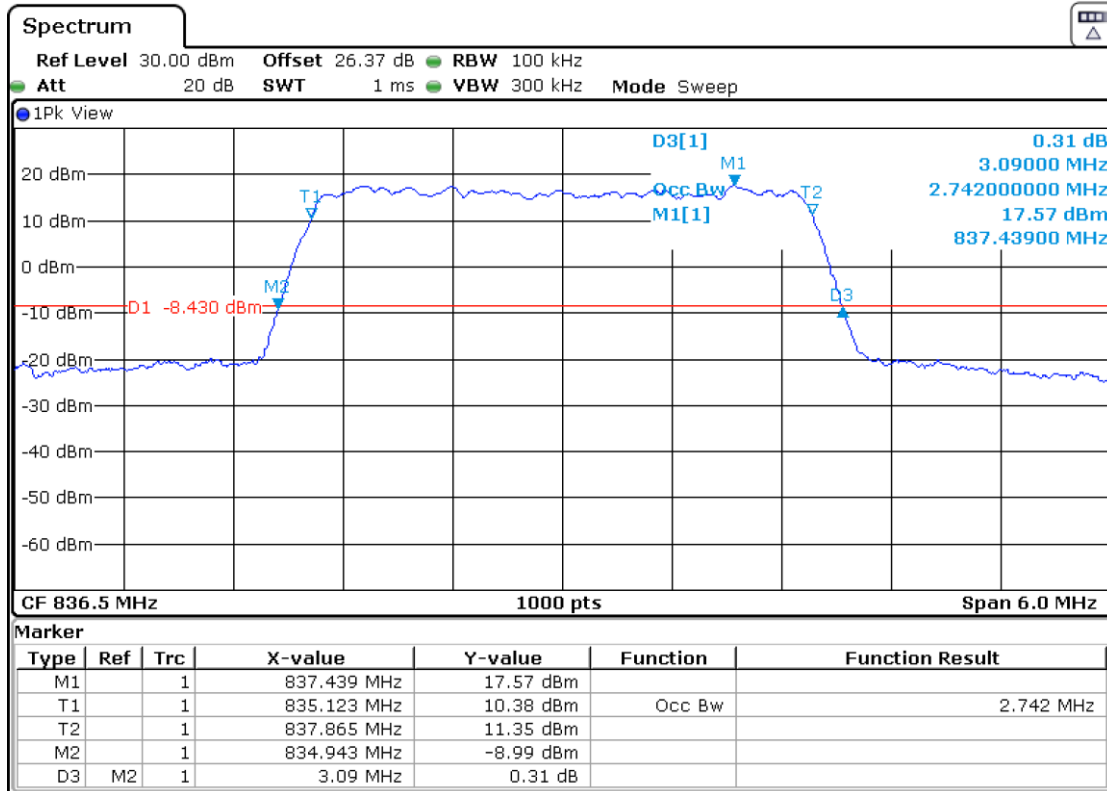

Highest Channel:

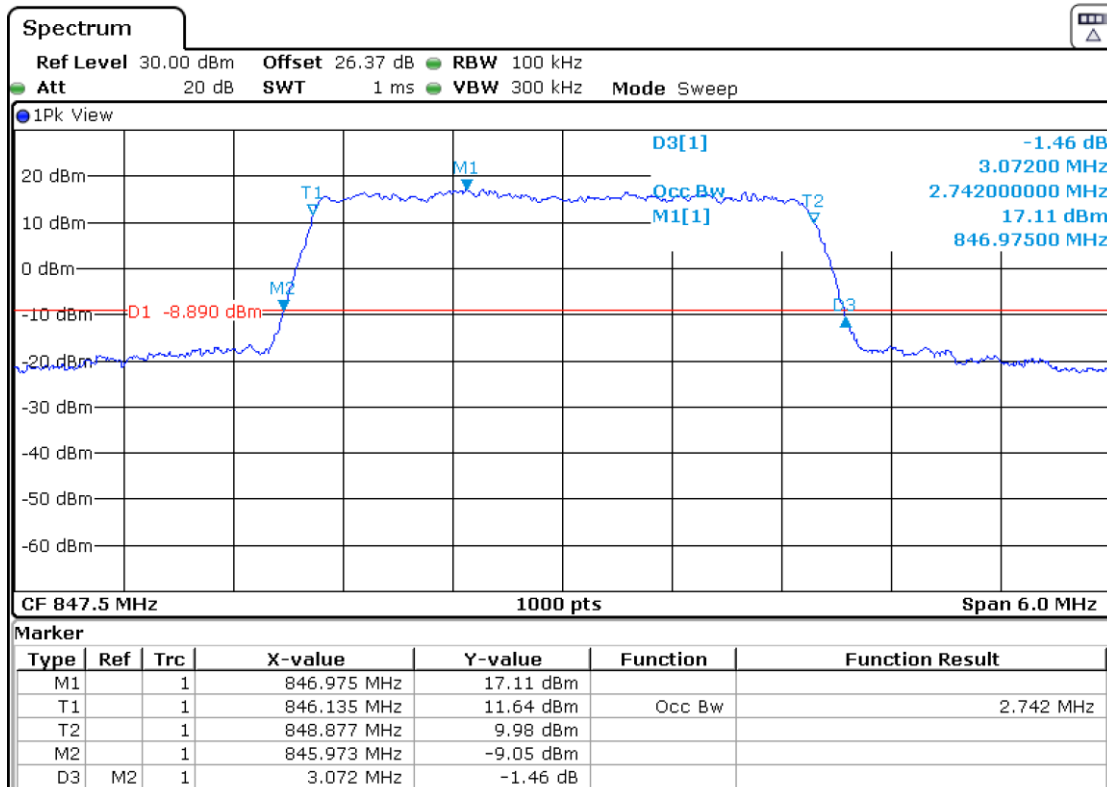

LTE Band 5. QPSK MODULATION. BW = 5 MHz.

Lowest Channel:

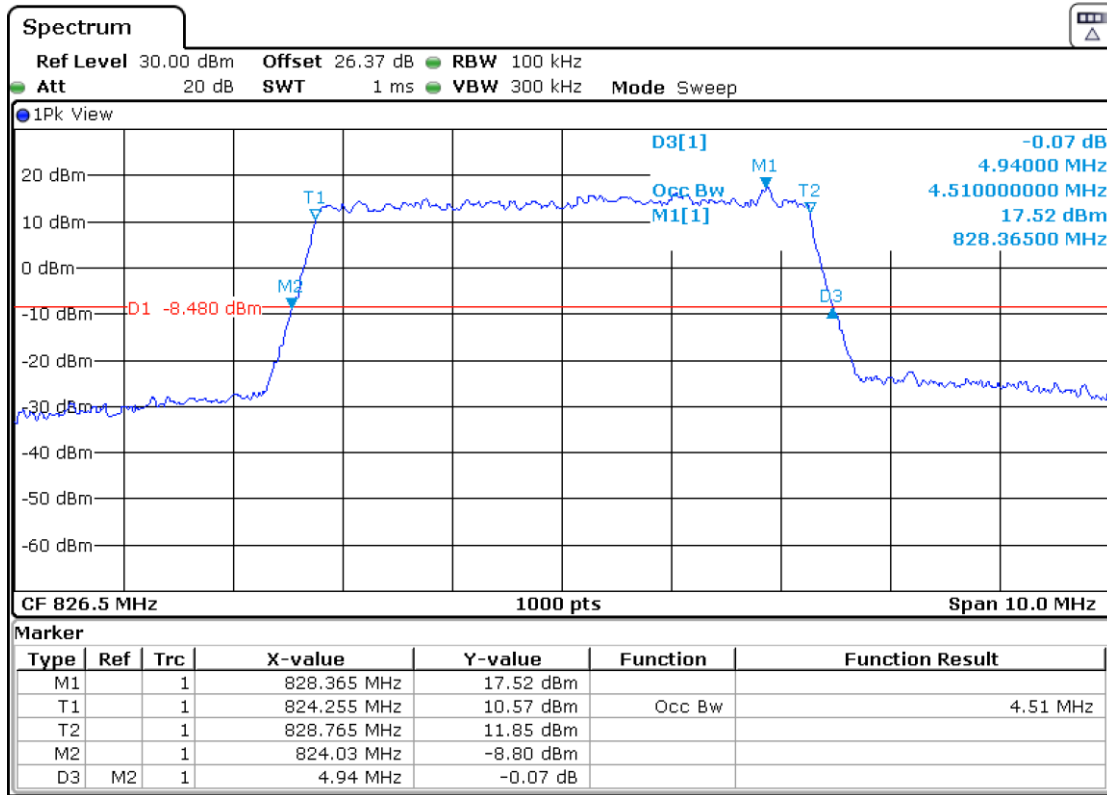

Middle Channel:

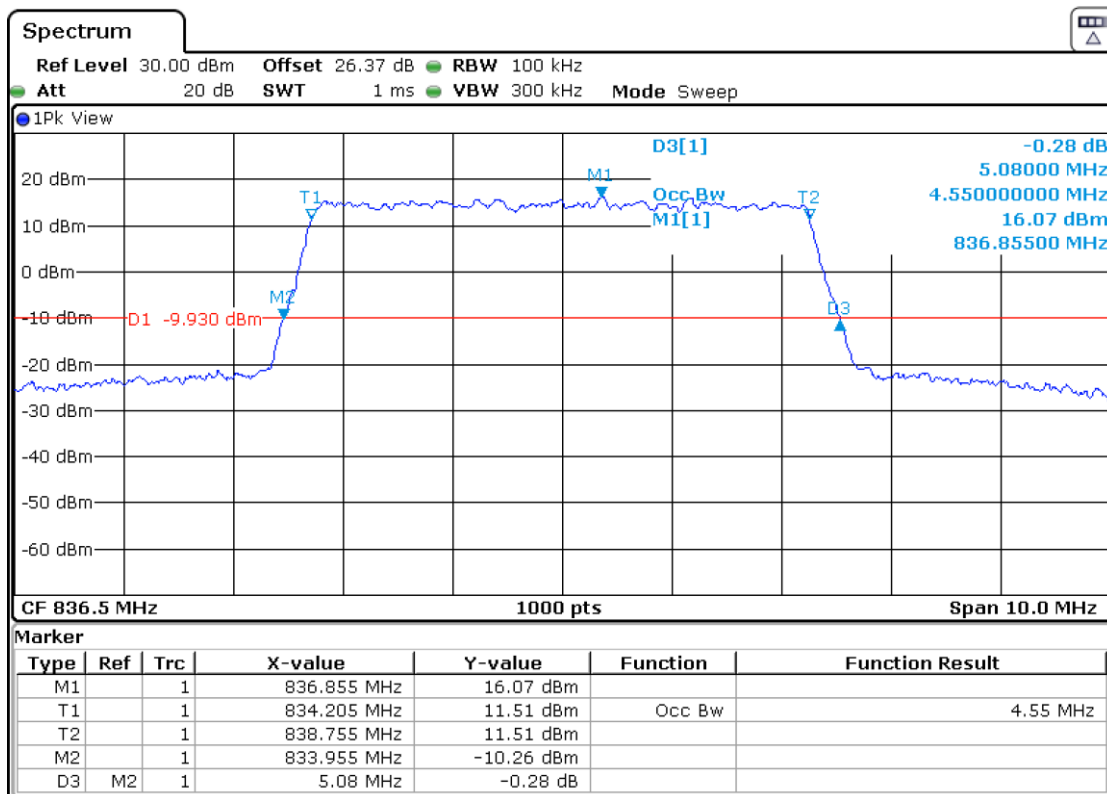

Highest Channel:

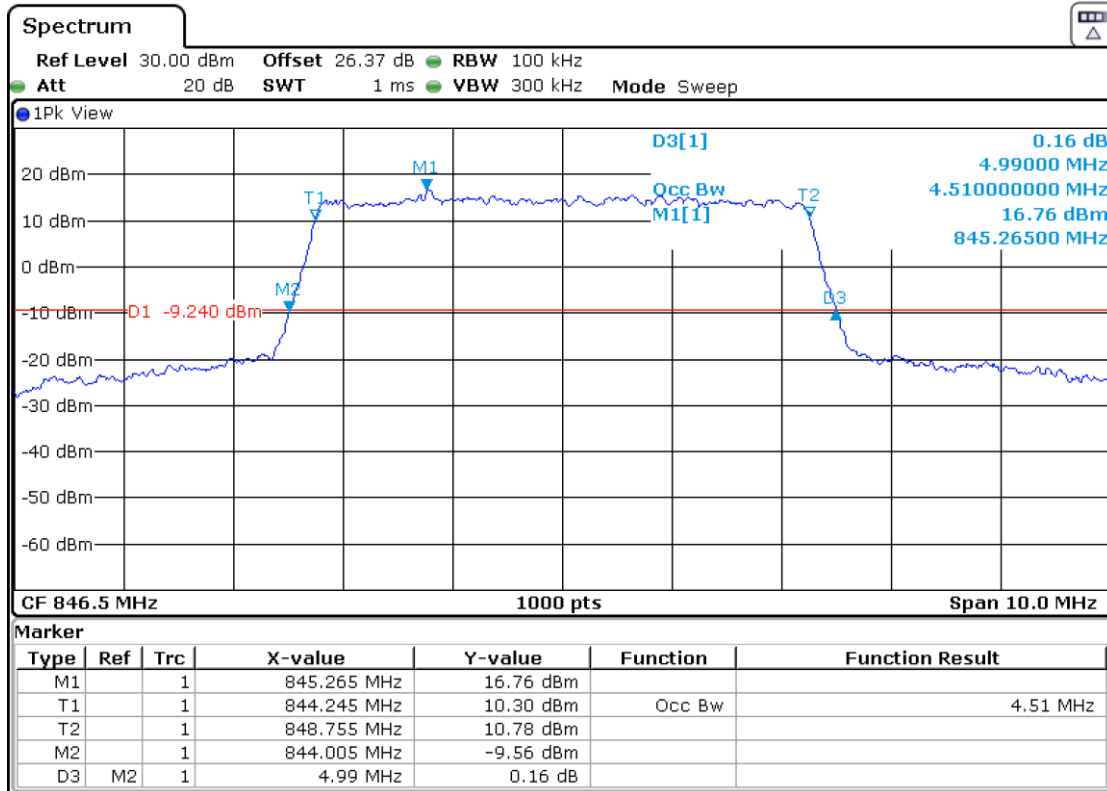

LTE Band 5. 16QAM MODULATION. BW = 5 MHz.

Lowest Channel:

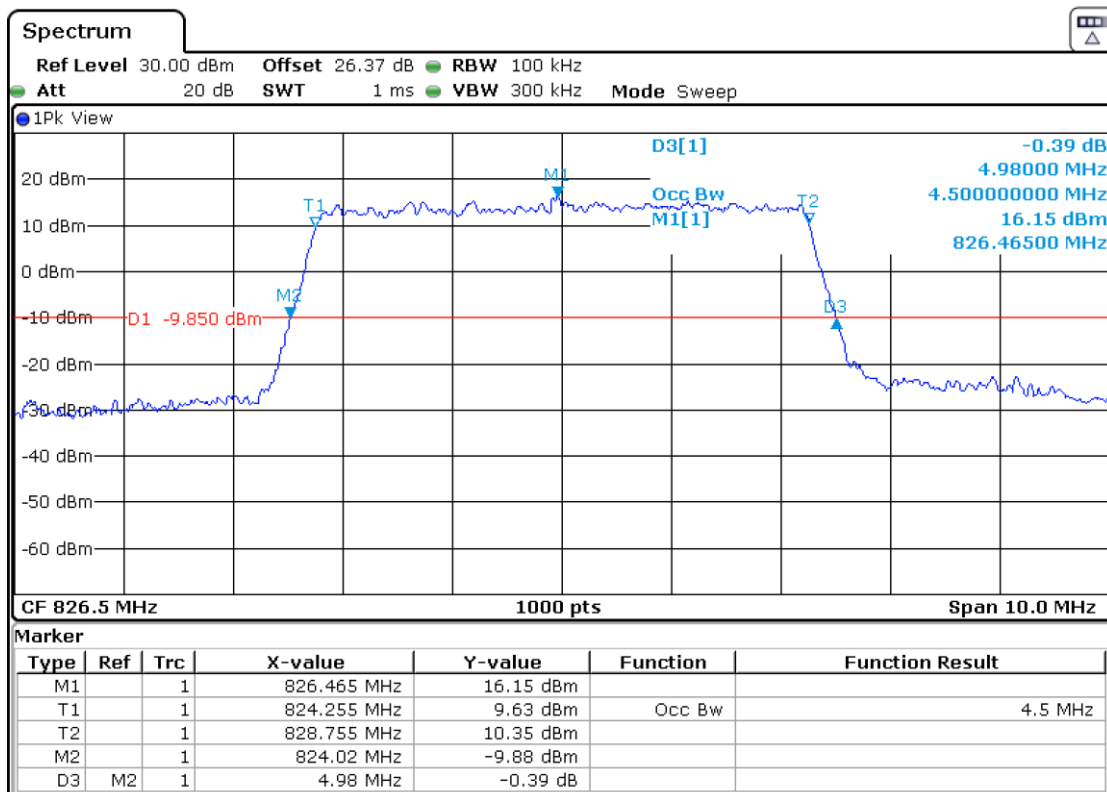

Middle Channel:

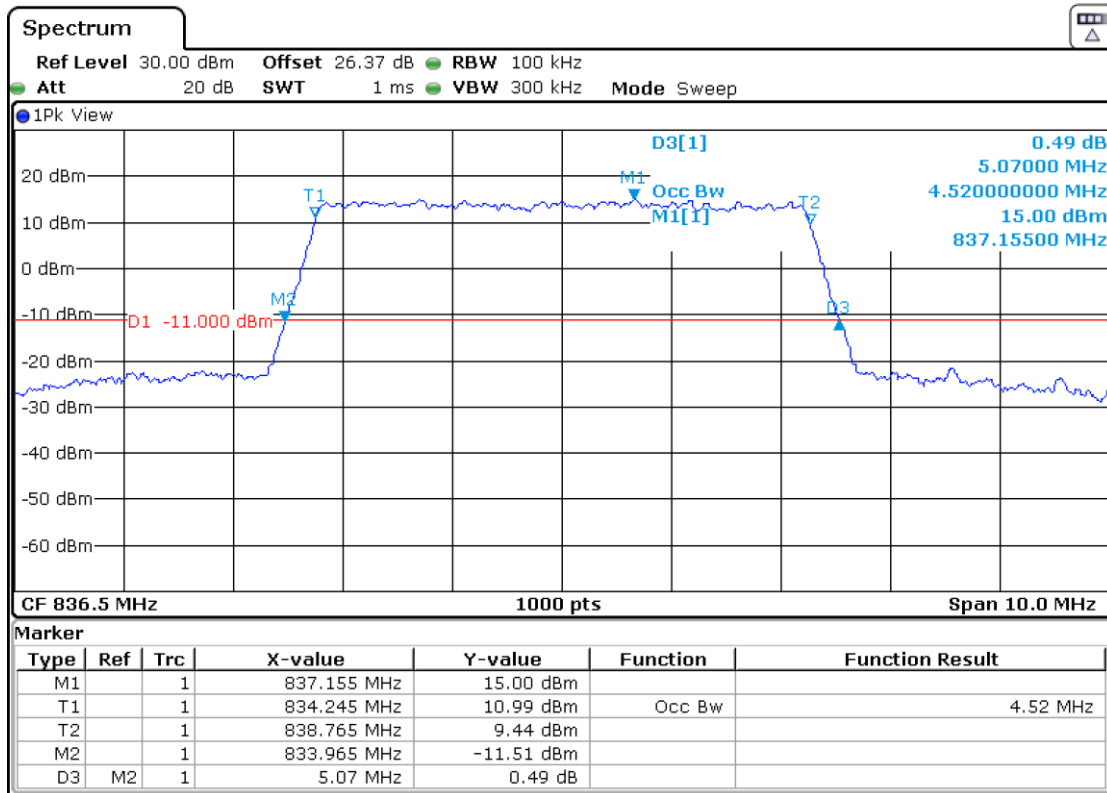

Highest Channel:

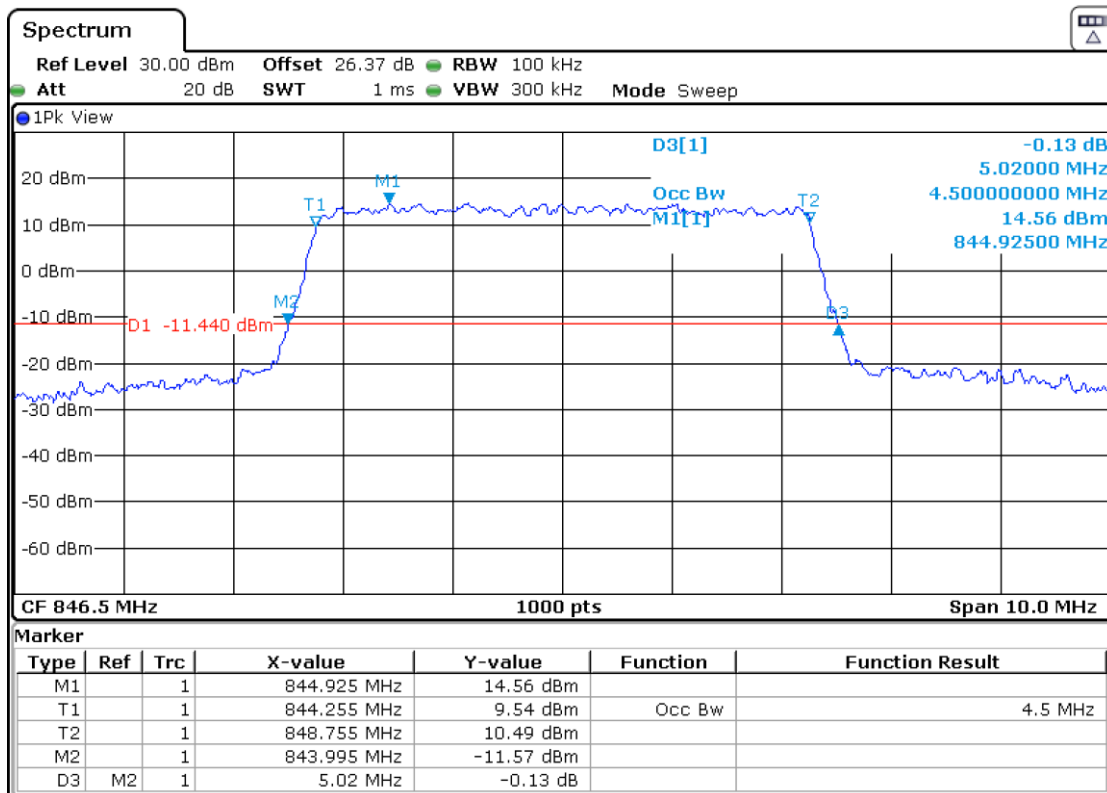

LTE Band 5. QPSK MODULATION. BW = 10 MHz.

Lowest Channel:

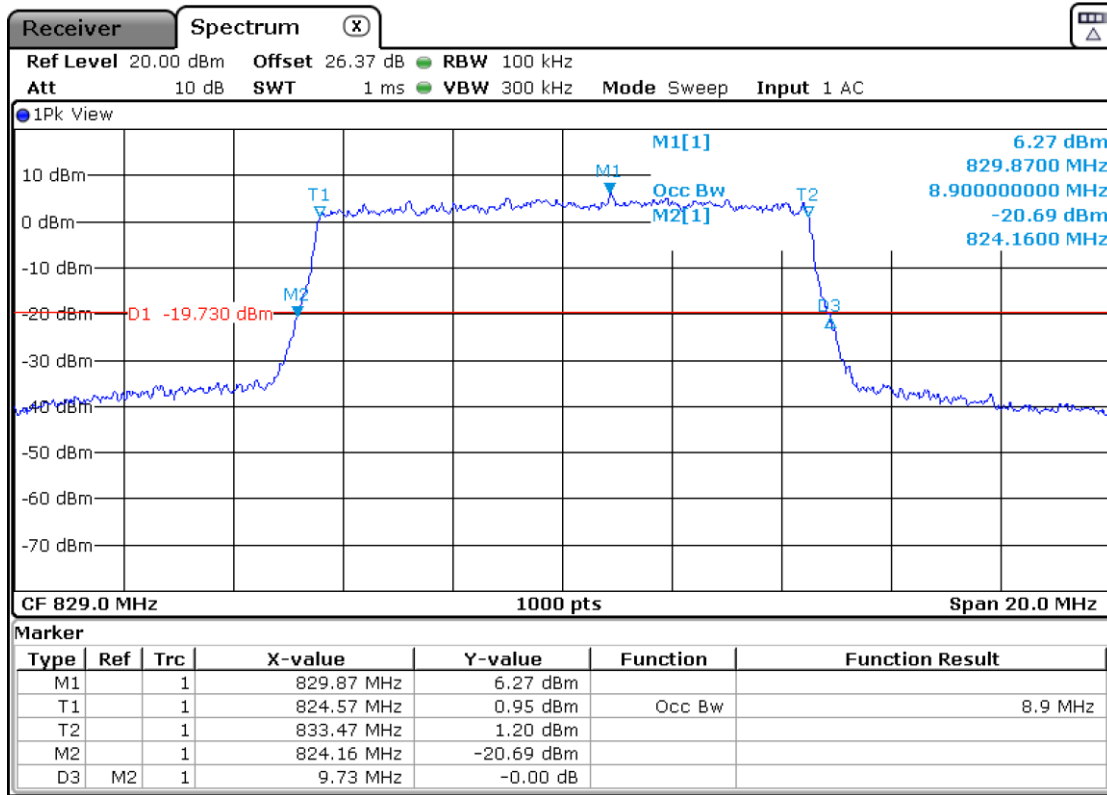

Middle Channel:

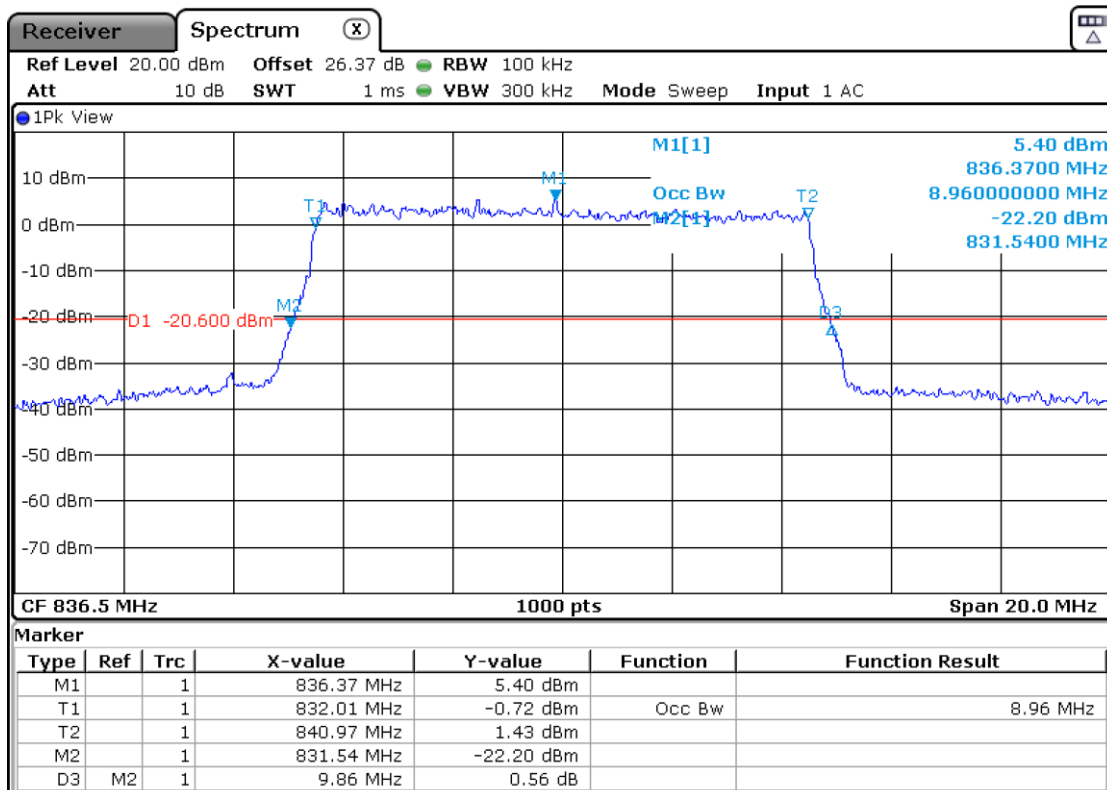

Highest Channel:

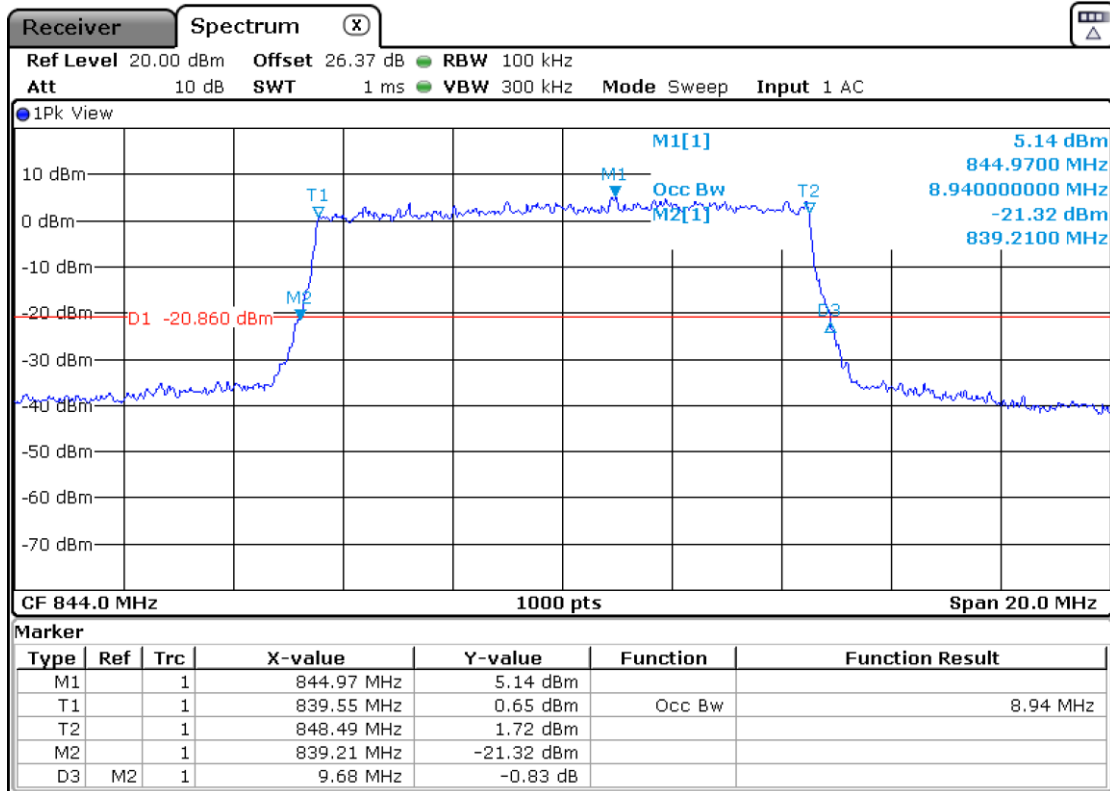

Spurious emissions at antenna terminals

SPECIFICATION:

FCC §2.1051 and §22.917

RSS-132. Clause 5.5.

The power of emissions shall be attenuated below the transmitter power (P) by a factor of at least $43 + 10 \log (P)$ dB. P in watts.

METHOD:

The EUT RF output connector was connected to a spectrum analyser and to the Universal Radio Communication tester R&S CMU200 and CMW500 (selecting maximum transmission power of the EUT and different modes of modulation) using a 50 ohm attenuator and a power splitter.

The spectrum was investigated from 9 kHz to 10 GHz.

The reading of the spectrum analyser is corrected with the attenuation loss of connection between output terminal of EUT and input of the spectrum analyser.

Measurement Limit:

According to specification. the power of emissions shall be attenuated below the transmitter power (P) by a factor of at least $43 + 10 \log (P)$ dB. P in watts.

At P_o transmitting power. the specified minimum attenuation becomes $43+10\log (P_o)$. and the level in dBm relative P_o becomes:

$$P_o \text{ (dBm)} - [43 + 10 \log (P_o \text{ in mwatts}) - 30] = - 13 \text{ dBm}$$

TEST SETUP:

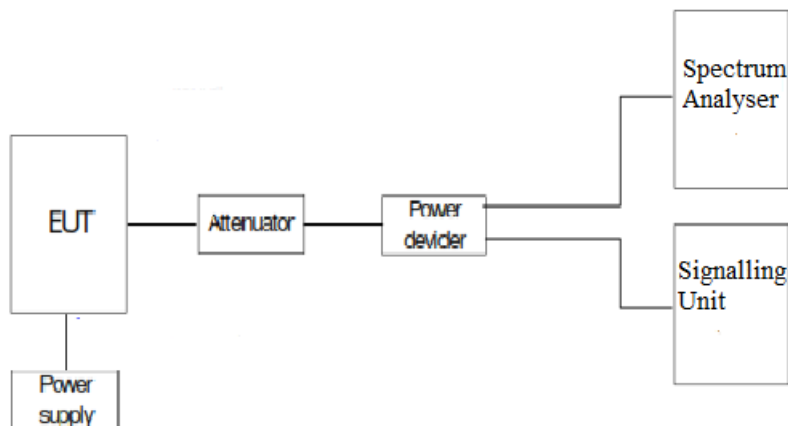

RESULTS:

3G Band V. WCDMA MODULATION.

- Lowest Channel:
No spurious frequencies detected at less than 20 dB below the limit.

- Middle Channel:
No spurious frequencies detected at less than 20 dB below the limit.

- Highest Channel:
No spurious frequencies detected at less than 20 dB below the limit.

Measurement uncertainty (dB)	<±1.56
------------------------------	--------

3G Band V. HSUPA MODULATION.

- Lowest Channel:
No spurious frequencies detected at less than 20 dB below the limit.

- Middle Channel:
No spurious frequencies detected at less than 20 dB below the limit.

- Highest Channel:
No spurious frequencies detected at less than 20 dB below the limit.

Measurement uncertainty (dB)	<±1.56
------------------------------	--------

Verdict: PASS

LTE Band 5. QPSK MODULATION. BW = 1.4 MHz.

- Lowest Channel:

No spurious frequencies detected at less than 20 dB below the limit in all the range.

- Middle Channel:

No spurious frequencies detected at less than 20 dB below the limit in all the range.

- Highest Channel:

No spurious frequencies detected at less than 20 dB below the limit in all the range.

Measurement uncertainty (dB)	<±1.56
------------------------------	--------

LTE Band 5. QPSK MODULATION. BW = 3 MHz.

- Lowest Channel:

No spurious frequencies detected at less than 20 dB below the limit in all the range.

- Middle Channel:

No spurious frequencies detected at less than 20 dB below the limit in all the range.

- Highest Channel:

No spurious frequencies detected at less than 20 dB below the limit in all the range.

Measurement uncertainty (dB)	<±1.56
------------------------------	--------

LTE Band 5. QPSK MODULATION. BW = 5 MHz.

- Lowest Channel:

No spurious frequencies detected at less than 20 dB below the limit in all the range.

- Middle Channel:

No spurious frequencies detected at less than 20 dB below the limit in all the range.

- Highest Channel:

No spurious frequencies detected at less than 20 dB below the limit in all the range.

Measurement uncertainty (dB)	<±1.56
------------------------------	--------

LTE Band 5. QPSK MODULATION. BW = 10 MHz.

- Lowest Channel:

No spurious frequencies detected at less than 20 dB below the limit in all the range.

- Middle Channel:

No spurious frequencies detected at less than 20 dB below the limit in all the range.

- Highest Channel:

No spurious frequencies detected at less than 20 dB below the limit in all the range.

Measurement uncertainty (dB)	<±1.56
------------------------------	--------

Verdict: PASS

3G Band V. WCDMA MODULATION.

Lowest Channel:

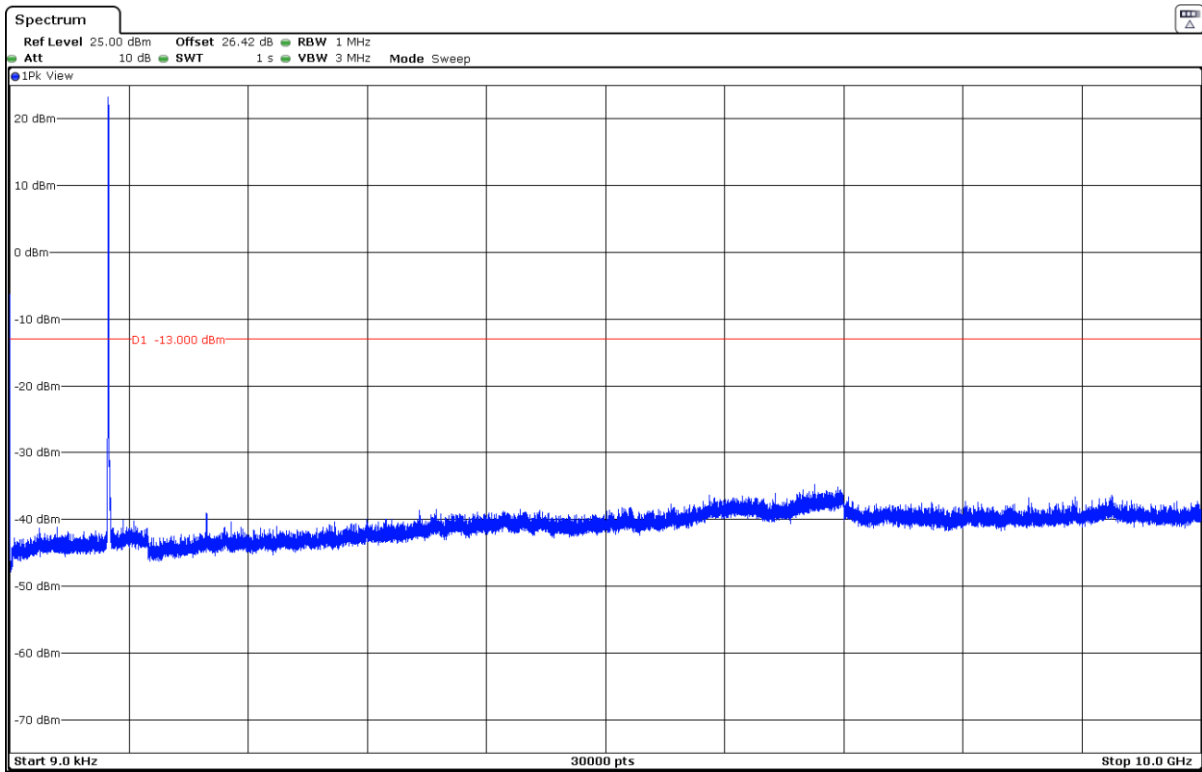

The peak above the limit is the carrier frequency.

Middle Channel:

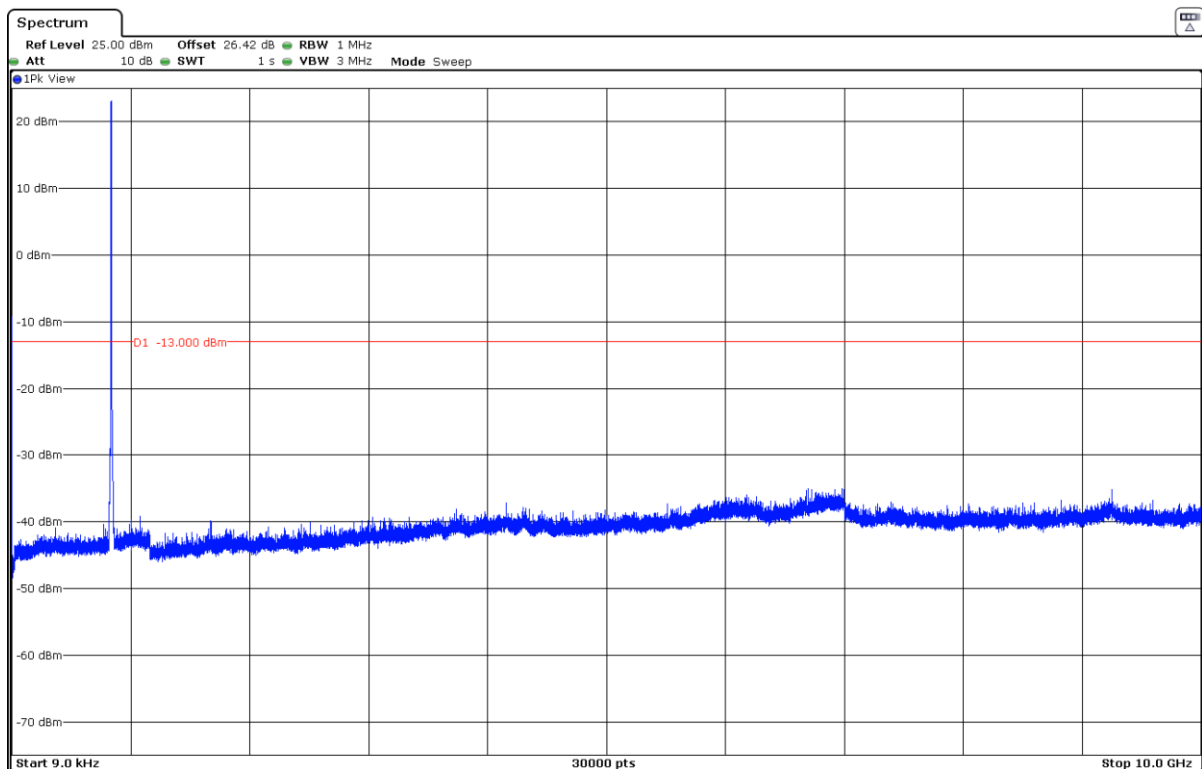

The peak above the limit is the carrier frequency.

Highest Channel:

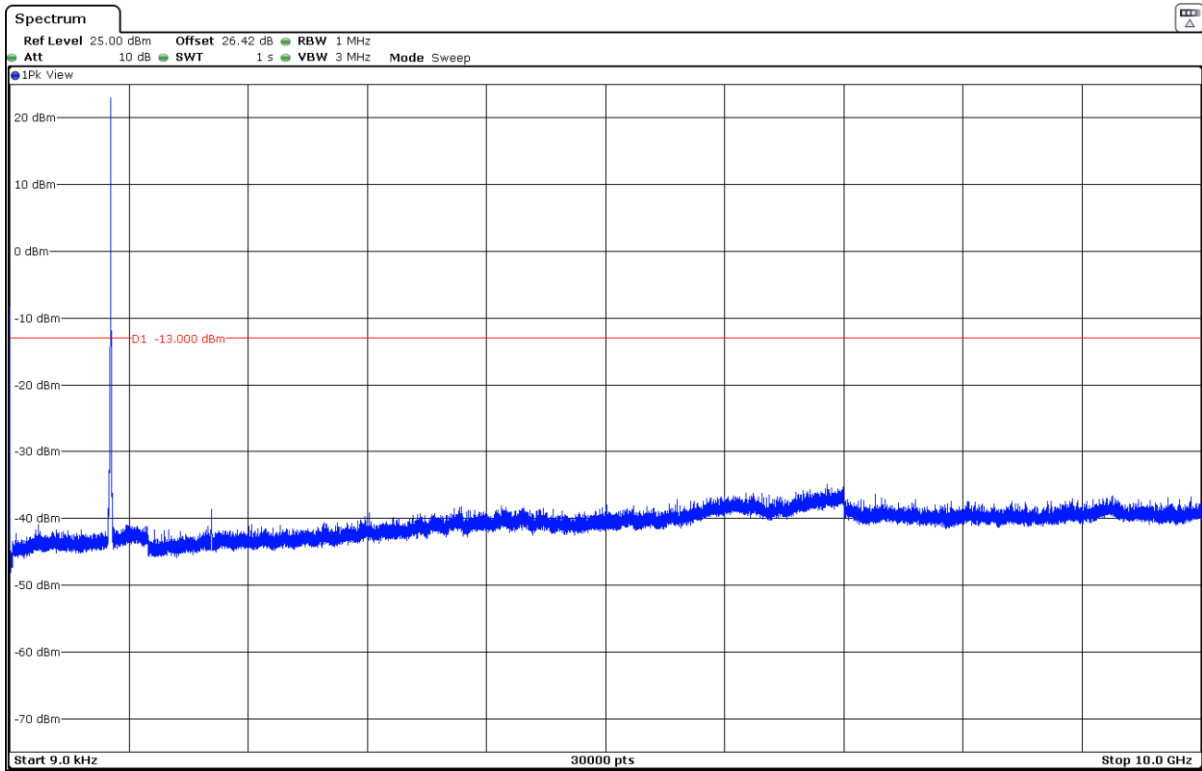

The peak above the limit is the carrier frequency.

3G Band V. HSUPA MODULATION.

Lowest Channel:

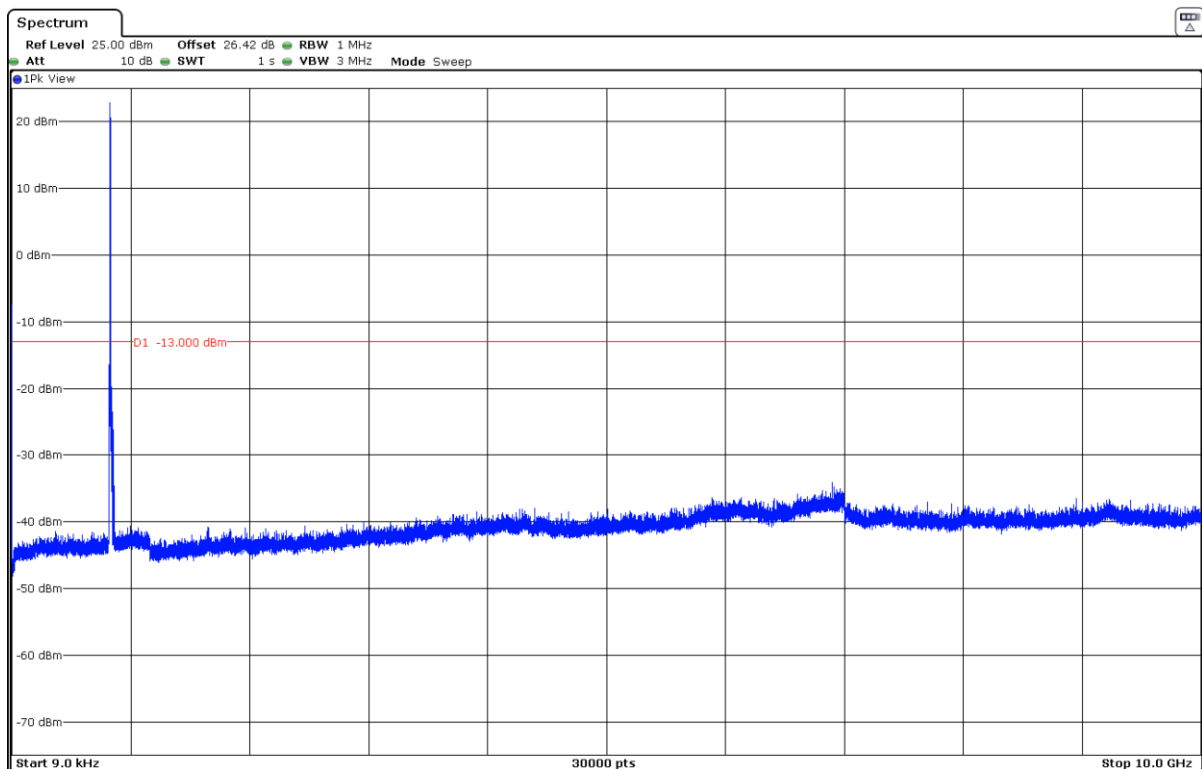

The peak above the limit is the carrier frequency.

Middle Channel:

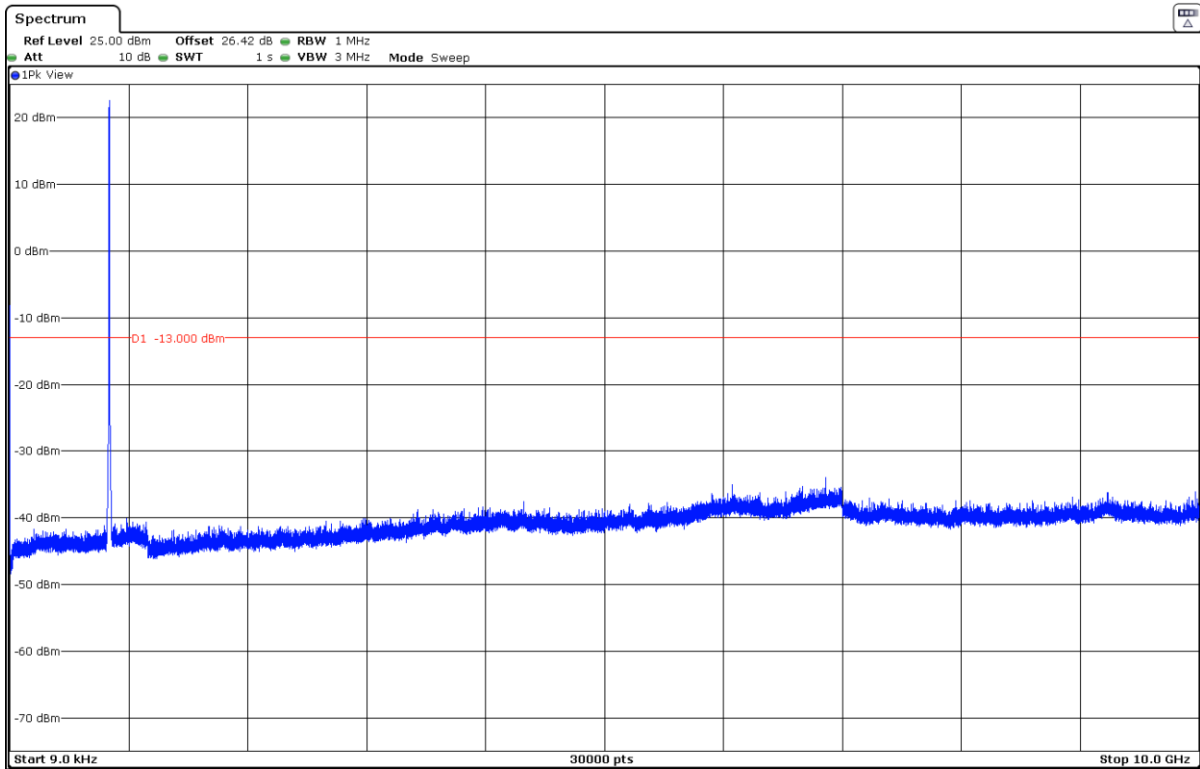

The peak above the limit is the carrier frequency.

Highest Channel:

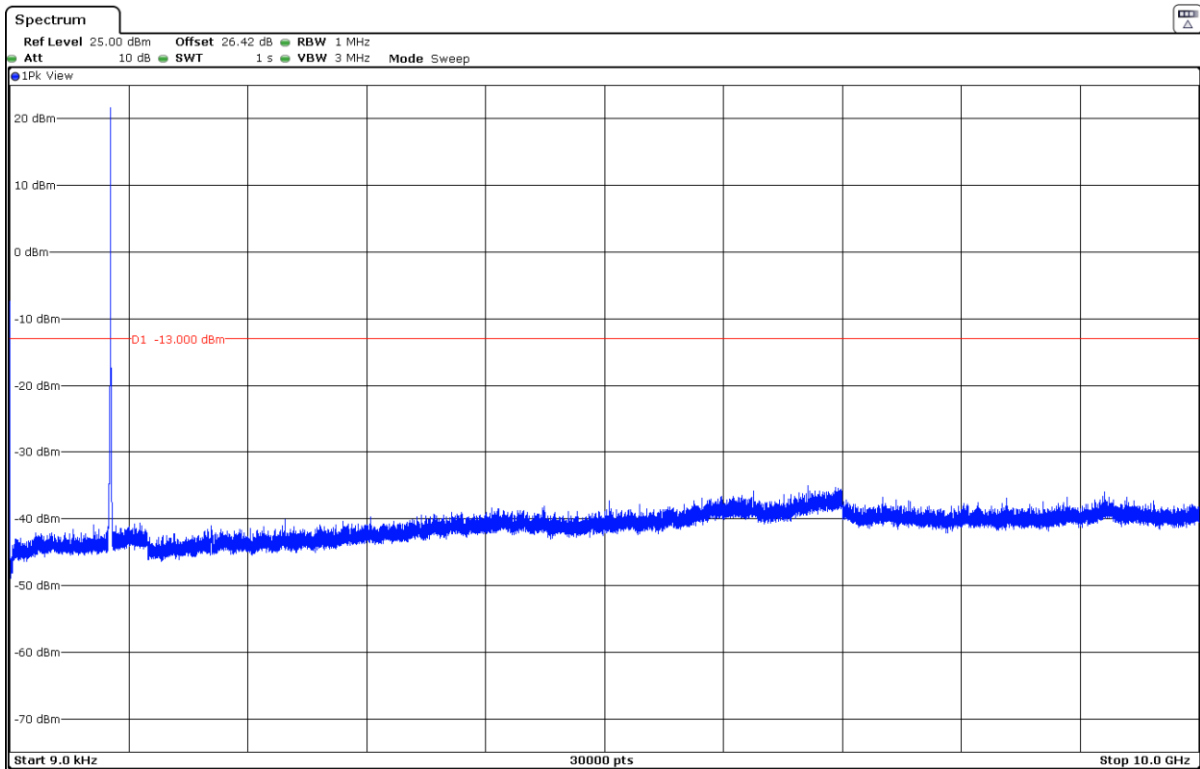

The peak above the limit is the carrier frequency.

LTE Band 5. QPSK MODULATION. BW = 1.4 MHz.

Lowest Channel:

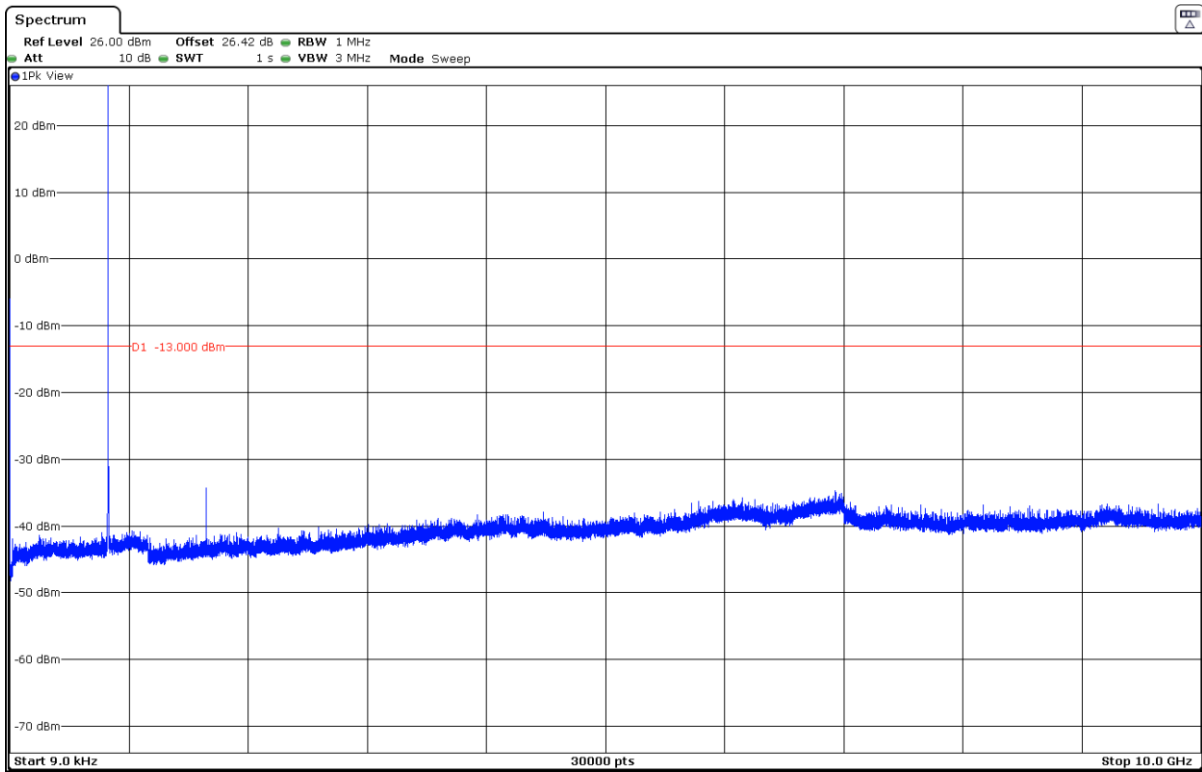

The peak above the limit is the carrier frequency.

Middle Channel:

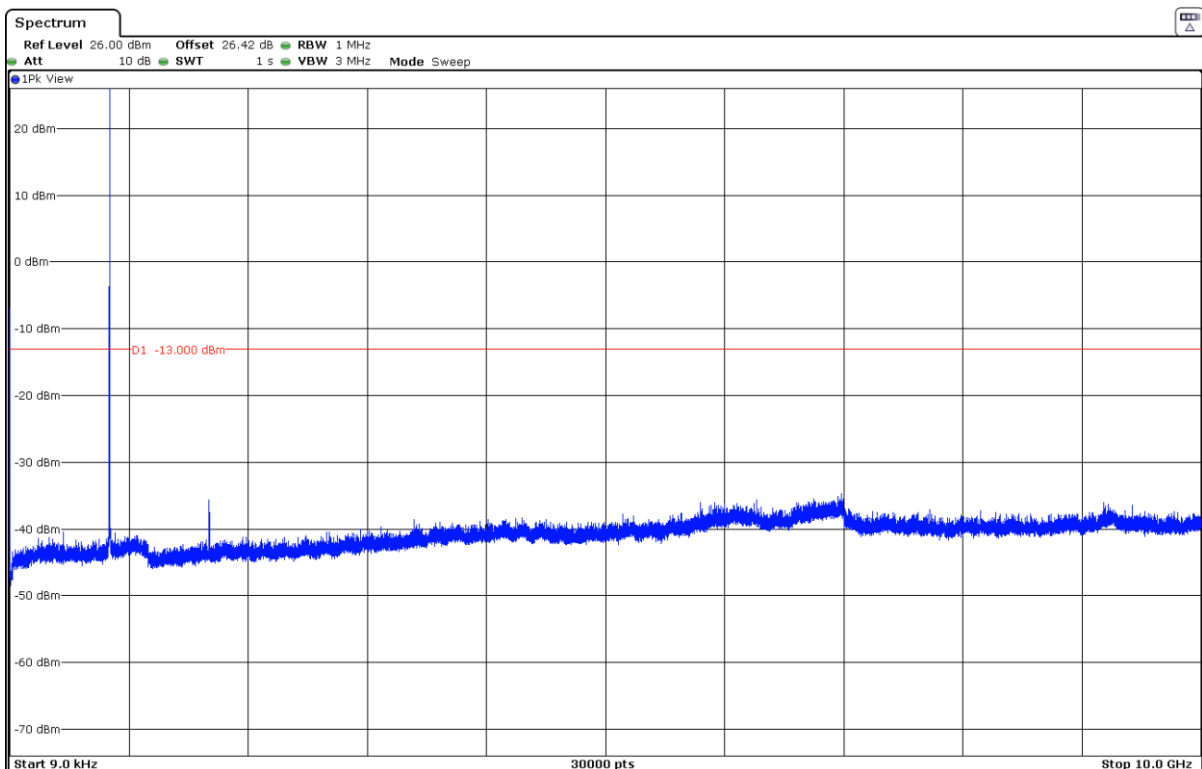

The peak above the limit is the carrier frequency.

Highest Channel:

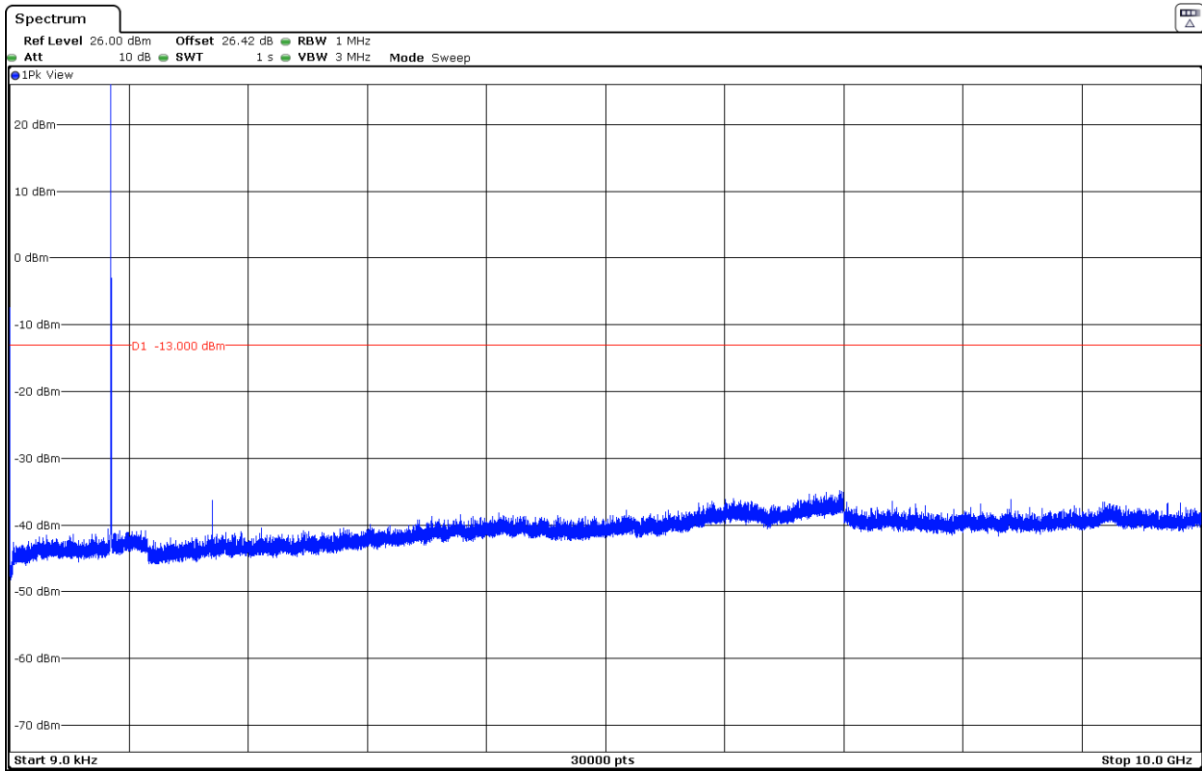

The peak above the limit is the carrier frequency.

LTE Band 5. QPSK MODULATION. BW = 3 MHz.

Lowest Channel:

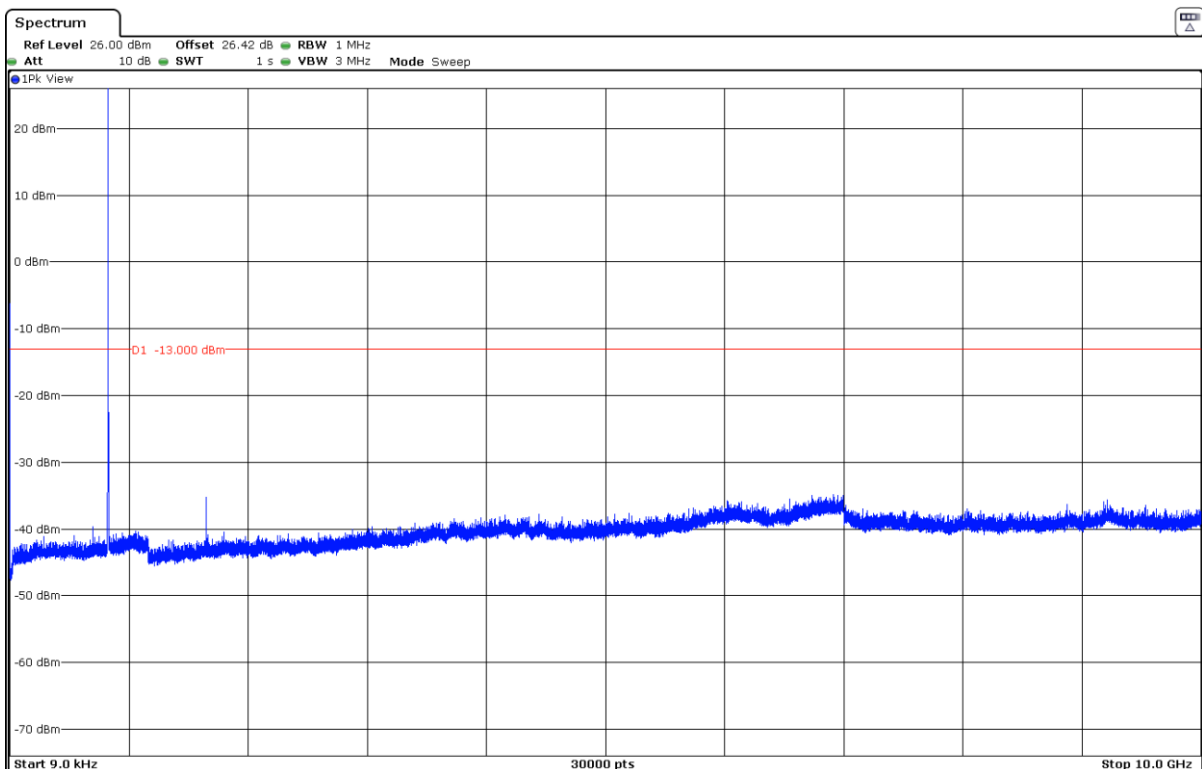

The peak above the limit is the carrier frequency.

Middle Channel:

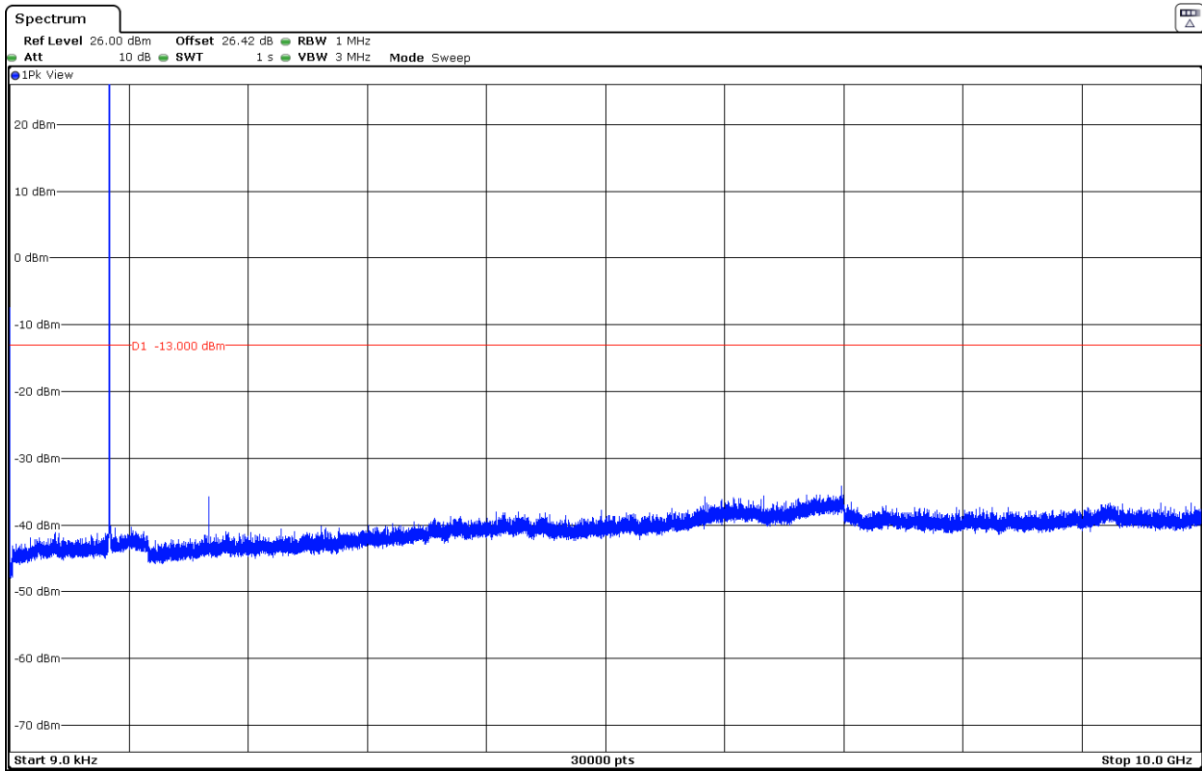

The peak above the limit is the carrier frequency.

Highest Channel:

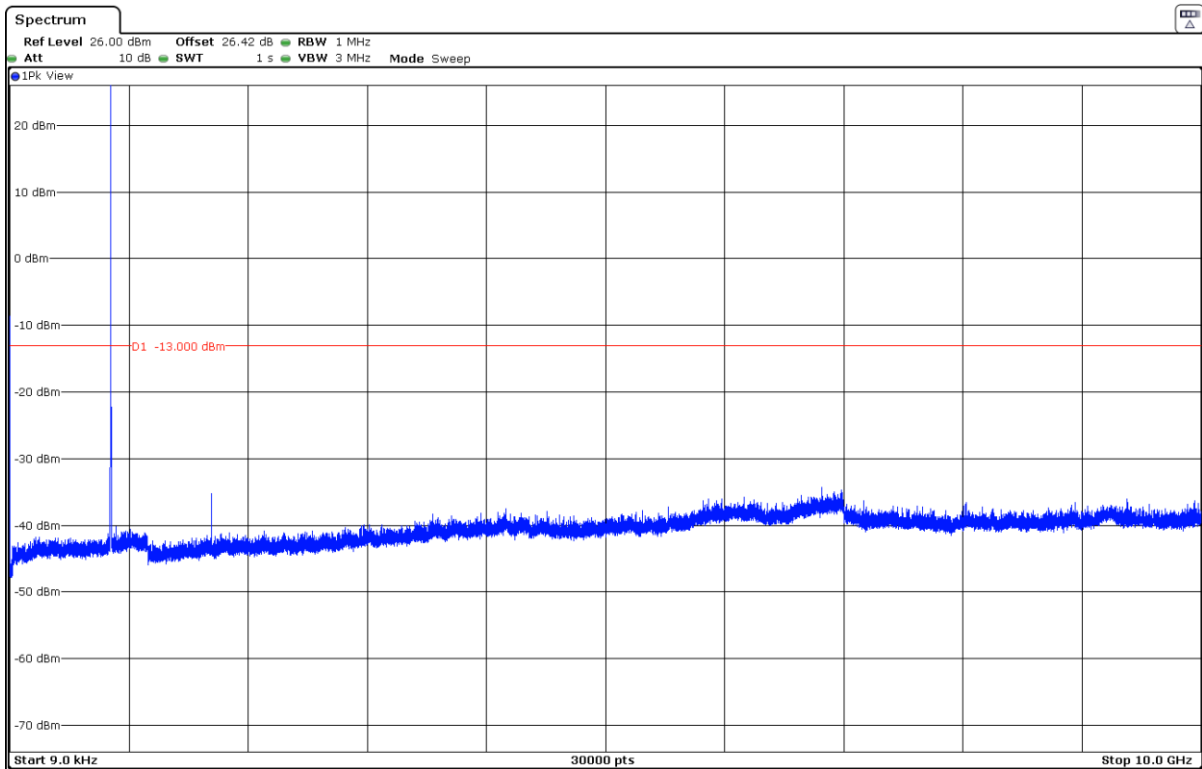

The peak above the limit is the carrier frequency.

LTE Band 5. QPSK MODULATION. BW = 5 MHz.

Lowest Channel:

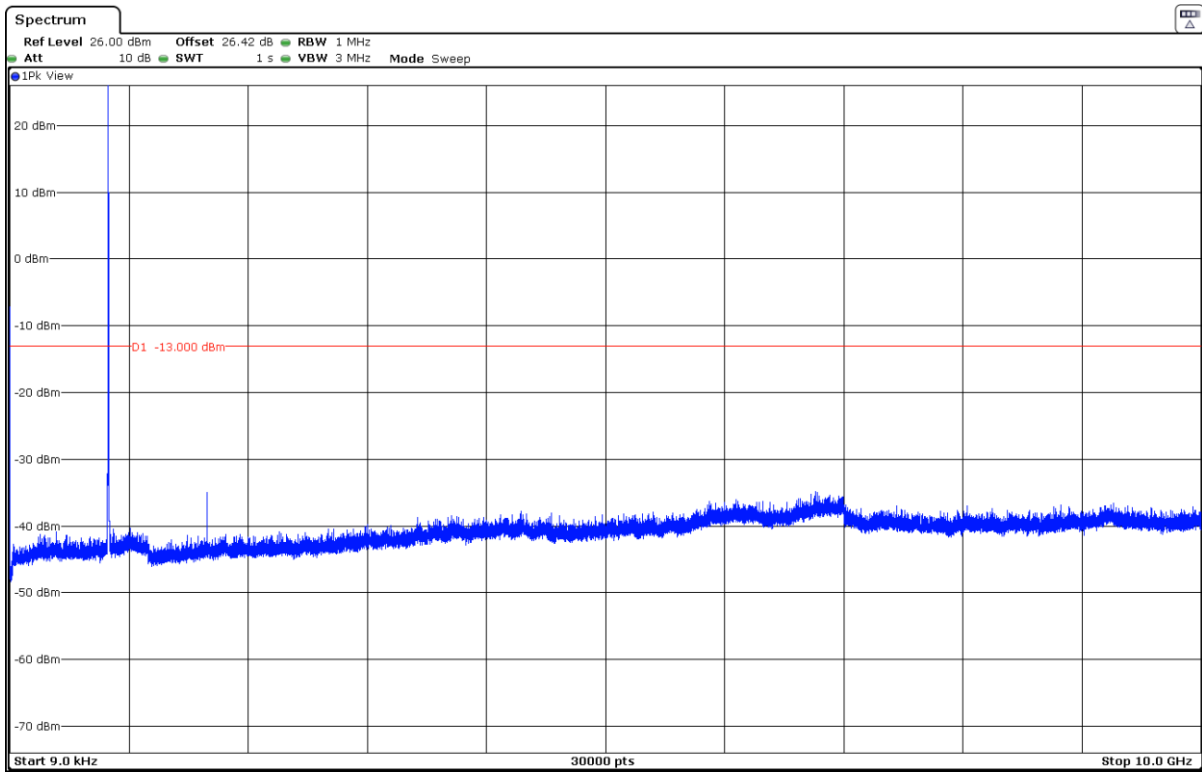

The peak above the limit is the carrier frequency.

Middle Channel:

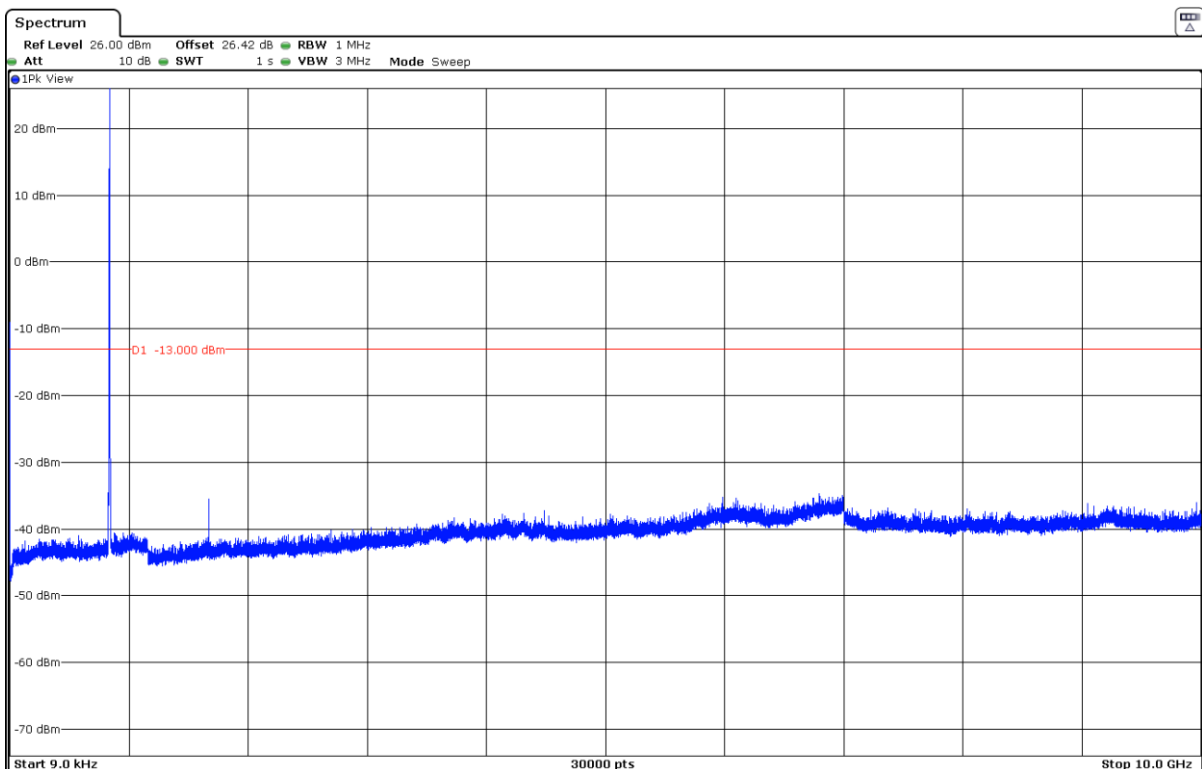

The peak above the limit is the carrier frequency.

Highest Channel:

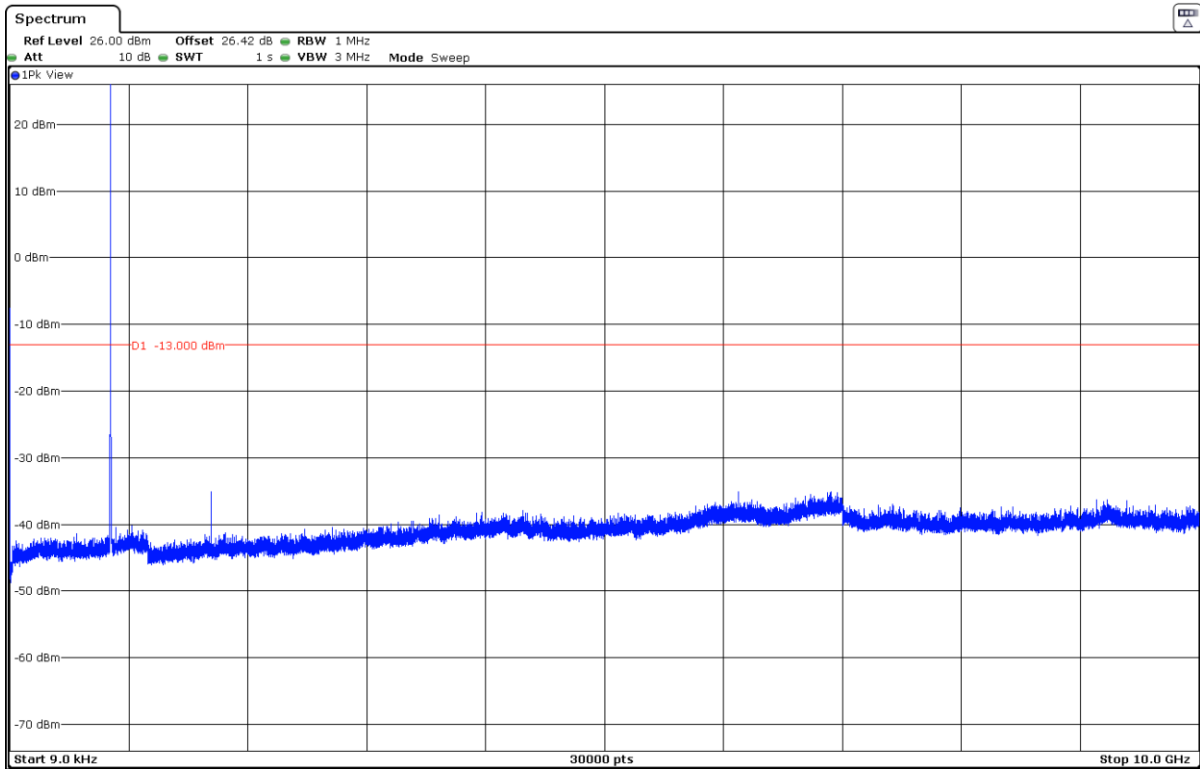

The peak above the limit is the carrier frequency.

LTE Band 5. QPSK MODULATION. BW = 10 MHz.

Lowest Channel:

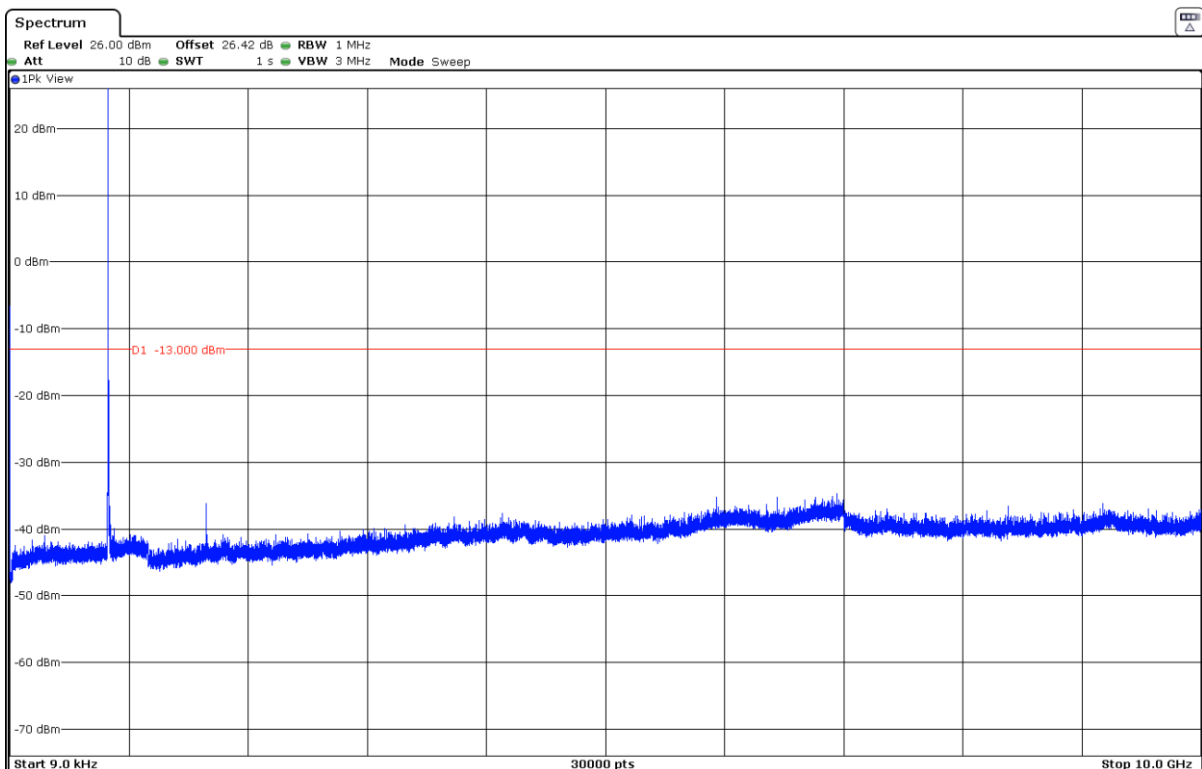

The peak above the limit is the carrier frequency.

Middle Channel:

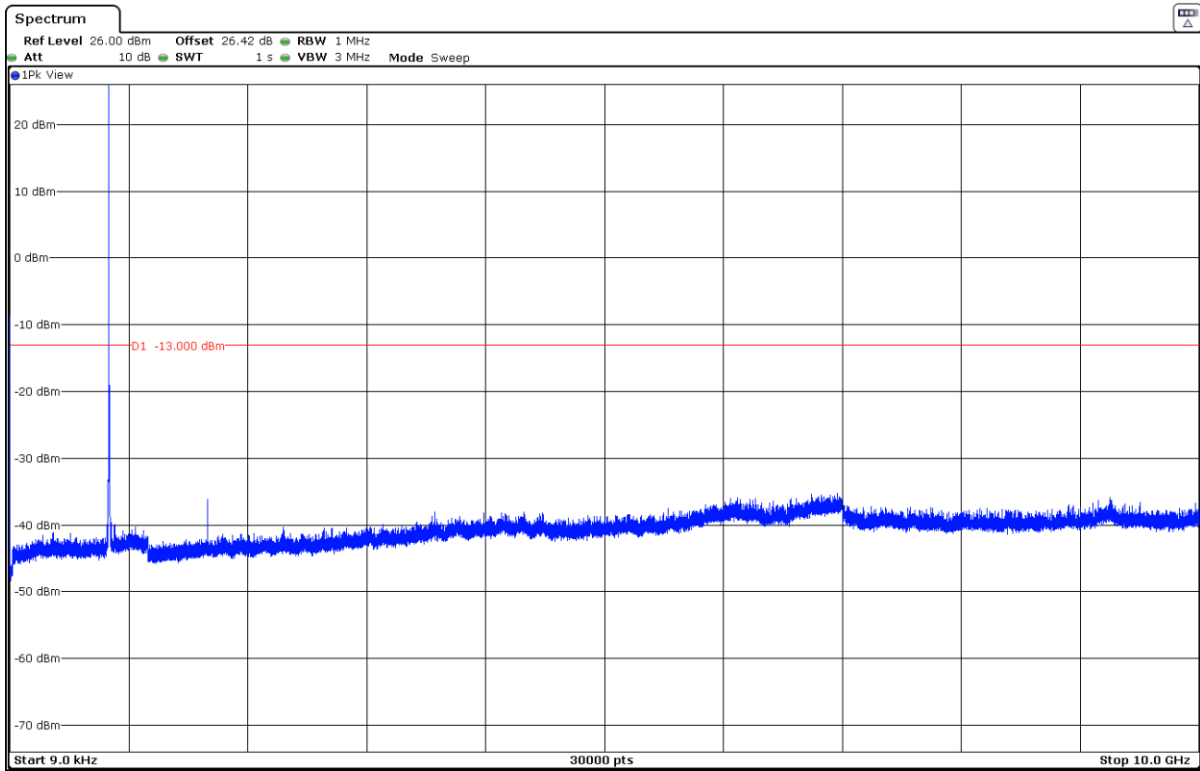

The peak above the limit is the carrier frequency.

Highest Channel:

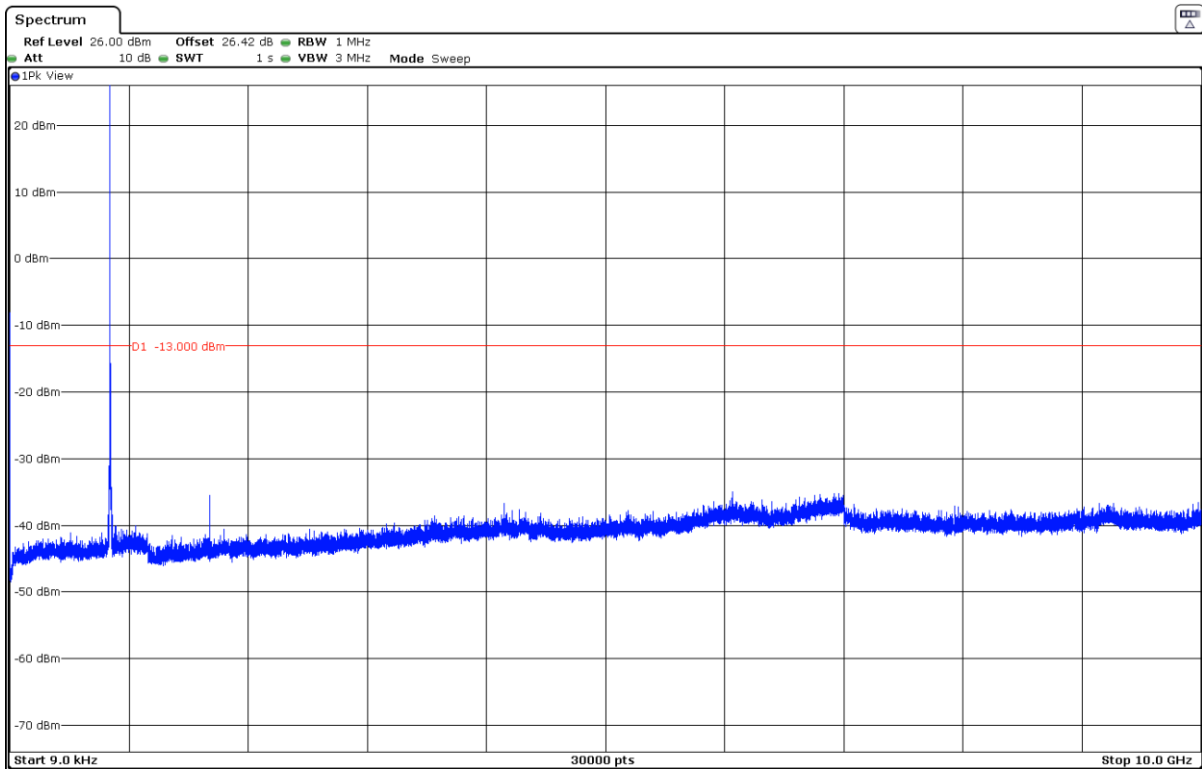

The peak above the limit is the carrier frequency.

Spurious emissions at antenna terminals at Block Edges

SPECIFICATION:

FCC §2.1051 and §22.917
RSS-132. Clause 5.5.

The power of emissions shall be attenuated below the transmitter power (P) by a factor of at least $43 + 10 \log (P)$ dB. P in watts.

METHOD:

The EUT RF output connector was connected to a spectrum analyser and to the Universal Radio Communication tester R&S CMW500 (selecting maximum transmission power of the EUT and different modes of modulation) using a 50 ohm attenuator and a power splitter.

As indicated in FCC part 22, in the 1 MHz bands immediately outside and adjacent to the frequency block or band a resolution bandwidth of at least one percent of the emission bandwidth of the fundamental emission of the transmitter may be employed.

Measurement Limit:

According to specification. the power of emissions shall be attenuated below the transmitter power (P) by a factor of at least $43 + 10 \log (P)$ dB. P in watts.

At P_o transmitting power. the specified minimum attenuation becomes $43+10\log (P_o)$. and the level in dBm relative P_o becomes:

$$P_o \text{ (dBm)} - [43 + 10 \log (P_o \text{ in mwatts}) - 30] = - 13 \text{ dBm}$$

TEST SETUP:

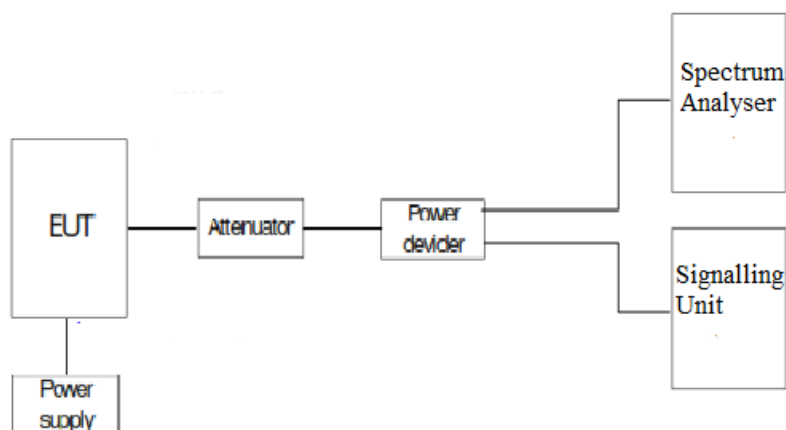

RESULTS:

3G Band V.

MODULATION:	WCDMA	HSUPA
Maximum measured level at <u>Lowest Block Edge</u> at antenna port (dBm)	-30.11	-30.28

MODULATION:	WCDMA	HSUPA
Maximum measured level at <u>Highest Block Edge</u> at antenna port (dBm)	-29.25	-29.76

Measurement uncertainty = ±1.57 dB.

Verdict: PASS

LTE Band 5.

LTE QPSK MODULATION:	RB=1, Offset=0, BW=1.4 MHz	RB=1, Offset=0, BW=3 MHz	RB=1, Offset=0, BW=5 MHz	RB=1, Offset=0, BW=10 MHz
Maximum measured level at <u>Lowest Block Edge</u> at antenna port (dBm)	-23.68	-20.22	-21.72	-41.25

LTE QPSK MODULATION:	RB=All, Offset=0, BW=1.4 MHz	RB=All, Offset=0, BW=3 MHz	RB=All, Offset=0, BW=5 MHz	RB=All, Offset=0, BW=10 MHz
Maximum measured level at <u>Lowest Block Edge</u> at antenna port (dBm)	-29.4	-28.76	-28.89	-27.98

LTE QPSK MODULATION:	RB=1, Offset=Max, BW=1.4 MHz	RB=1, Offset=Max, BW=3 MHz	RB=1, Offset=Max, BW=5 MHz	RB=1, Offset=Max, BW=10 MHz
Maximum measured level at <u>Highest Block Edge</u> at antenna port (dBm)	-22.96	-20.91	-21.8	-22.05

LTE QPSK MODULATION:	RB=All, Offset=0, BW=1.4 MHz	RB=All, Offset=0, BW=3 MHz	RB=All, Offset=0, BW=5 MHz	RB=All, Offset=0, BW=10 MHz
Maximum measured level at <u>Highest Block Edge</u> at antenna port (dBm)	-26.1	-25.02	-26.52	-27.23

3G Band V. WCDMA MODULATION.

Lowest Channel:

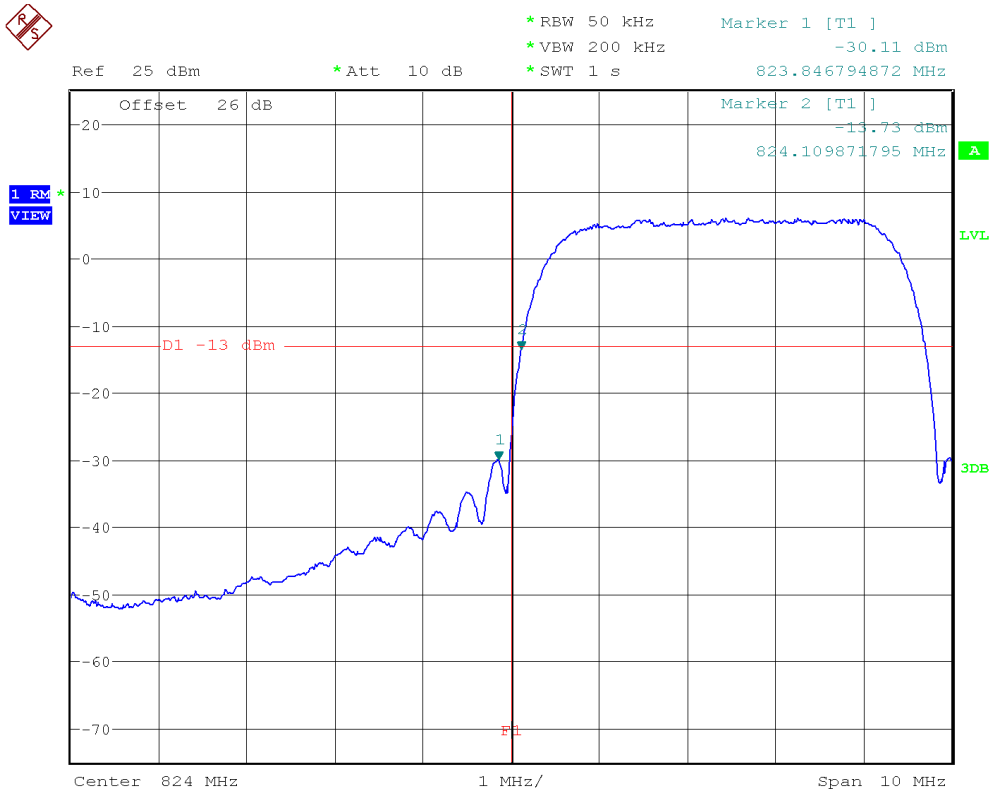

The equipment transmits at the maximum output power

Highest Channel:

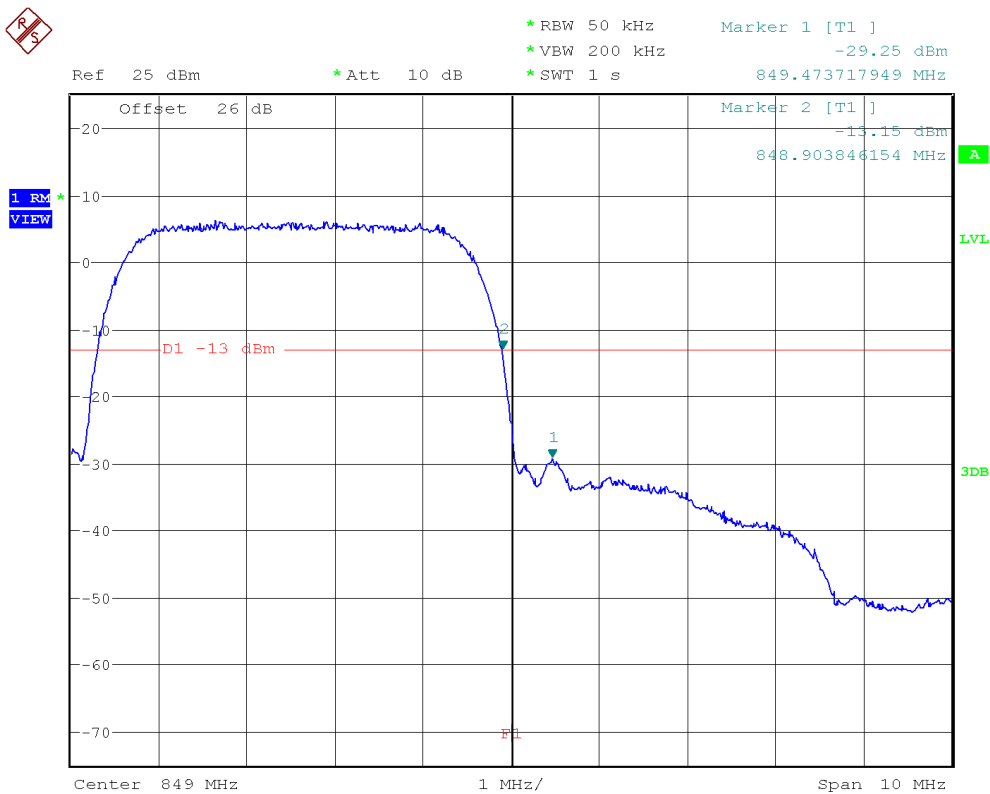

The equipment transmits at the maximum output power

3G Band V. HSUPA MODULATION.

Lowest Channel:

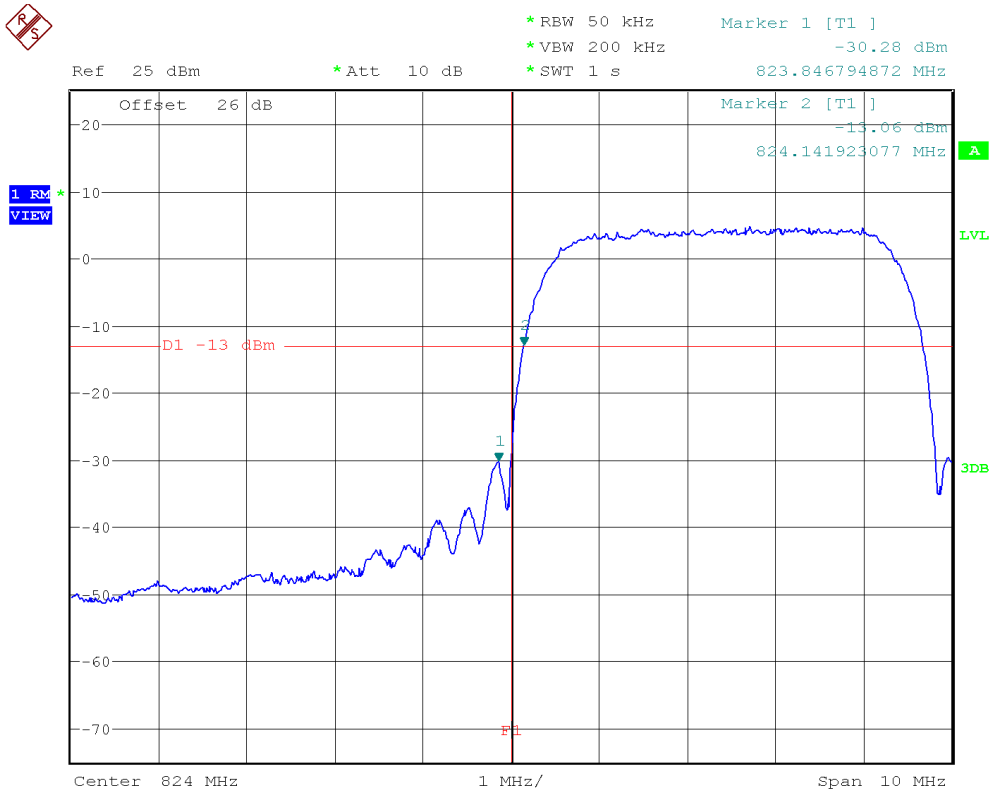

The equipment transmits at the maximum output power

Highest Channel:

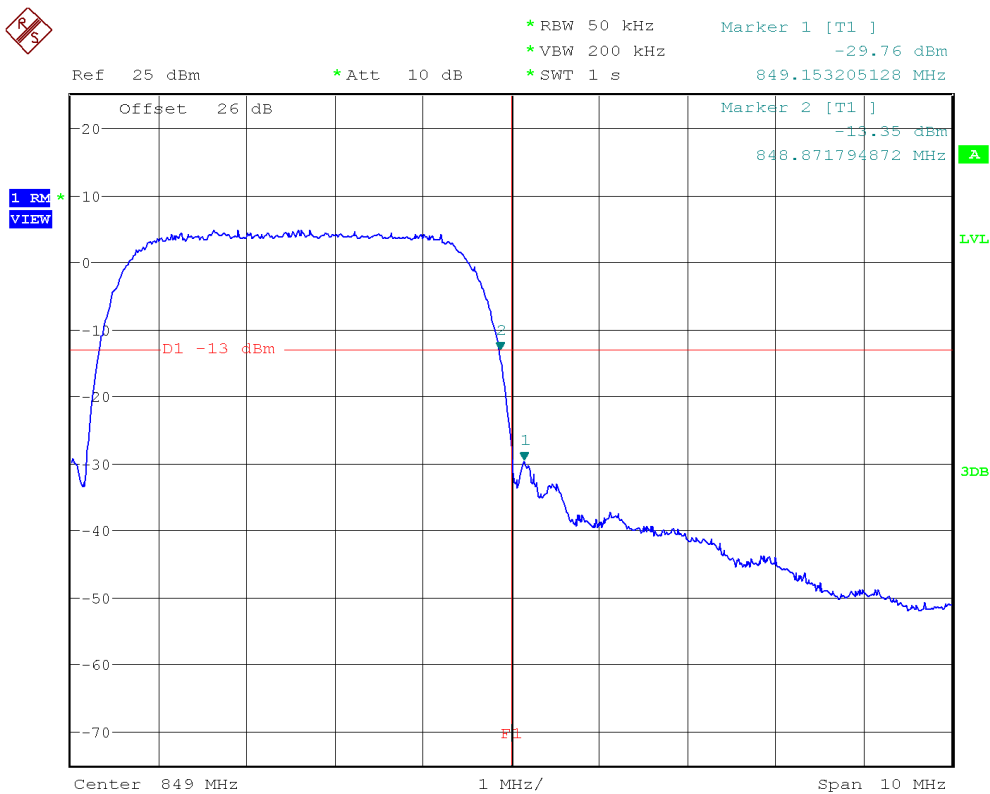

The equipment transmits at the maximum output power

LTE Band 5. QPSK MODULATION. BW=1.4 MHz. RB=1. Offset=0. Lowest Block Edge:

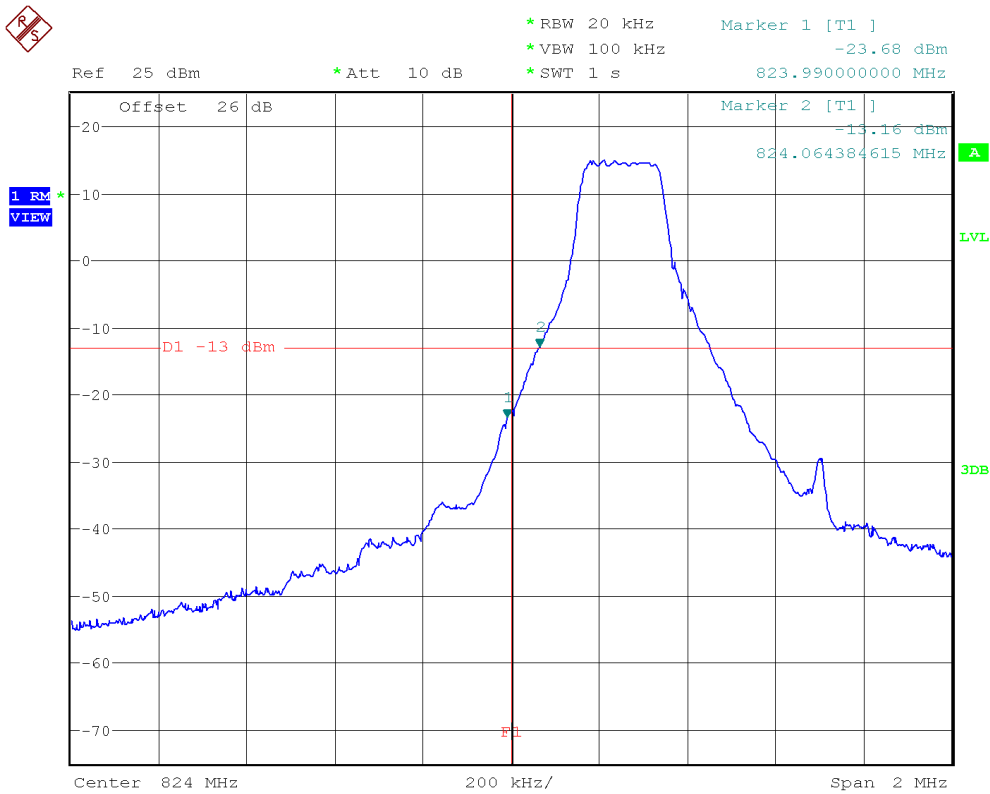

LTE Band 5. QPSK MODULATION. BW=1.4 MHz. RB=1. Offset=Max. Highest Block Edge:

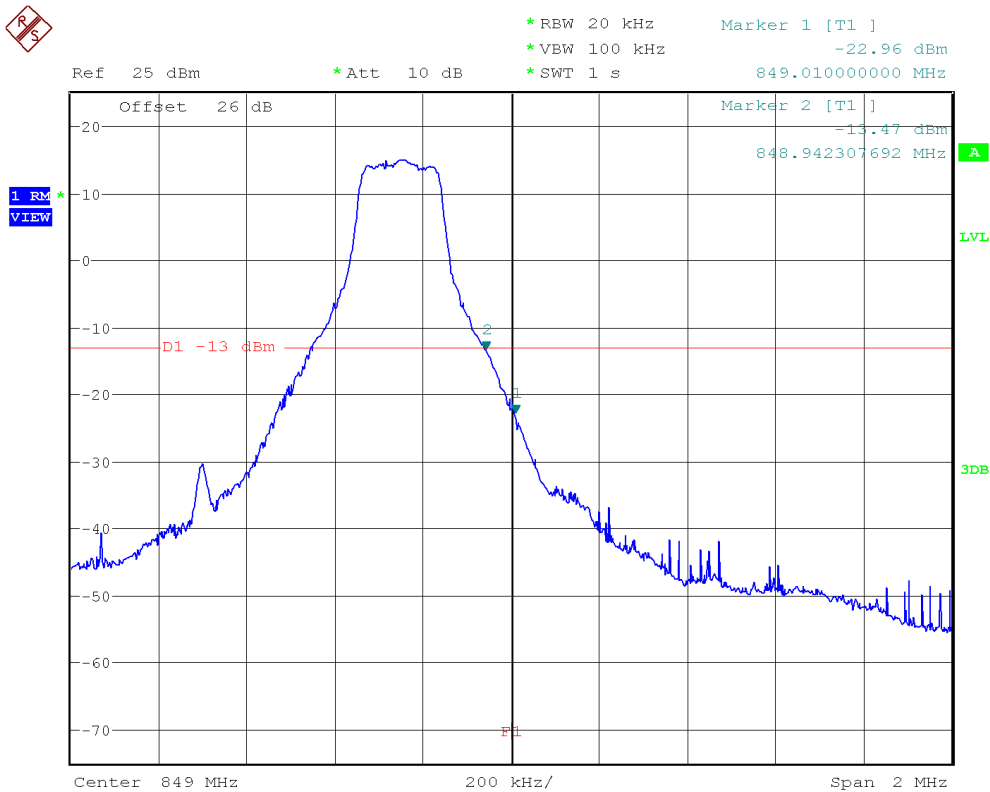

LTE Band 5. QPSK MODULATION. BW=1.4 MHz. RB=All. Offset=0. Lowest and Highest Block Edges:

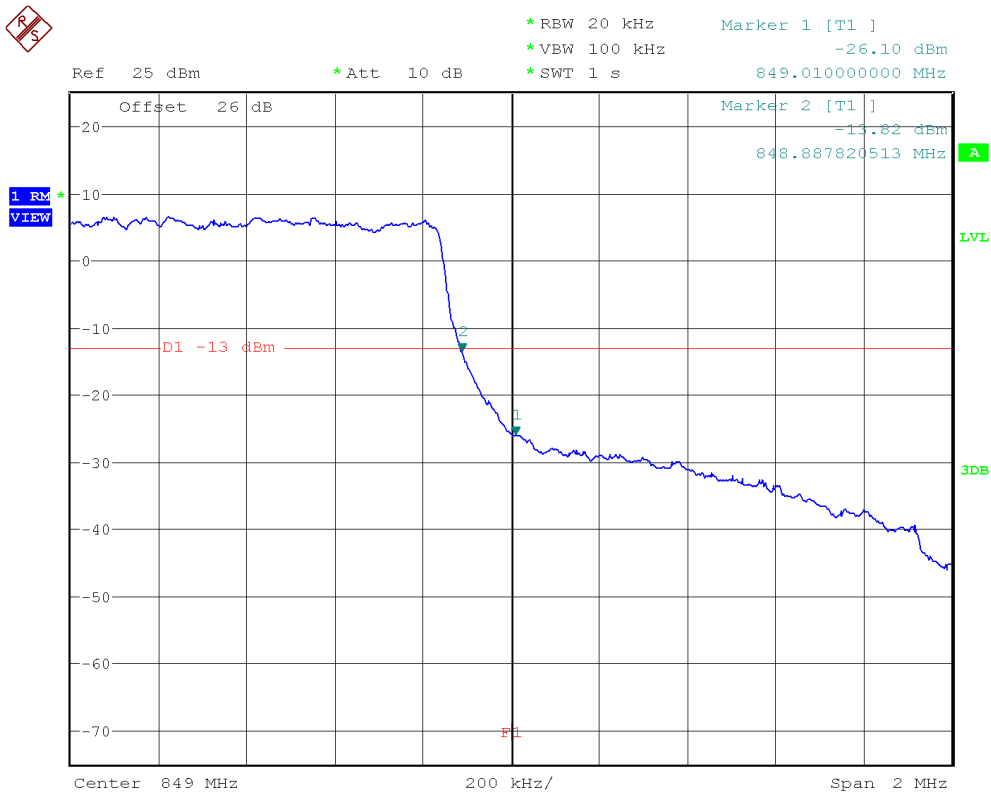
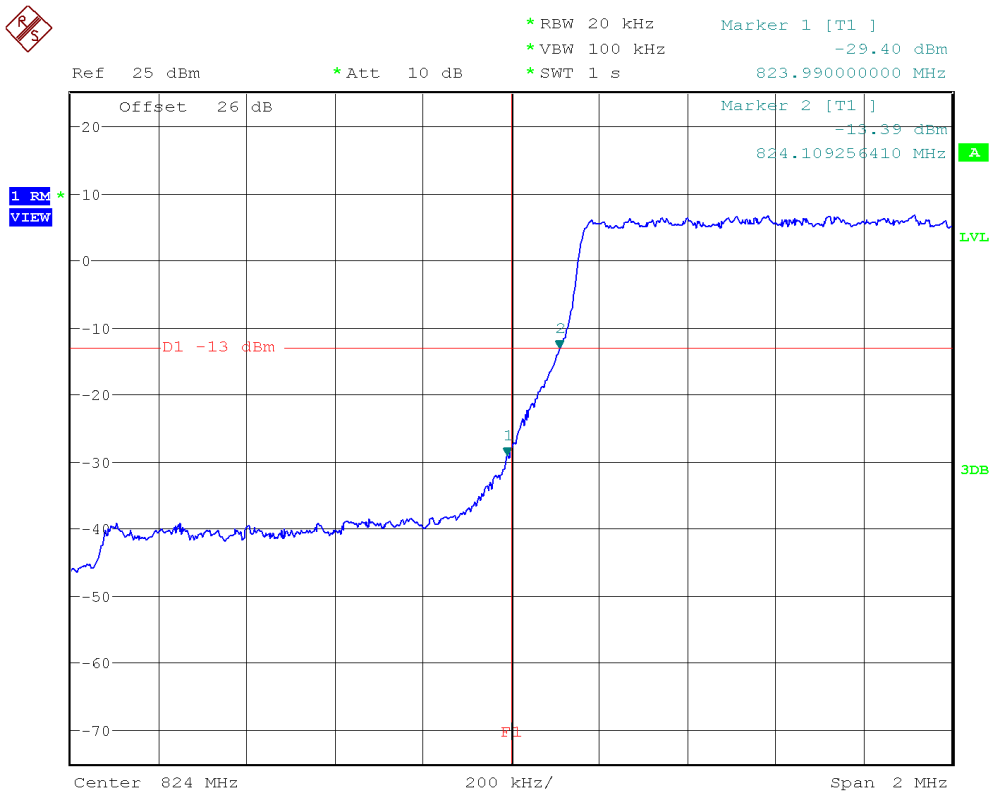

LTE Band 5. QPSK MODULATION. BW=3 MHz. RB=1. Offset=0. Lowest Block Edge:

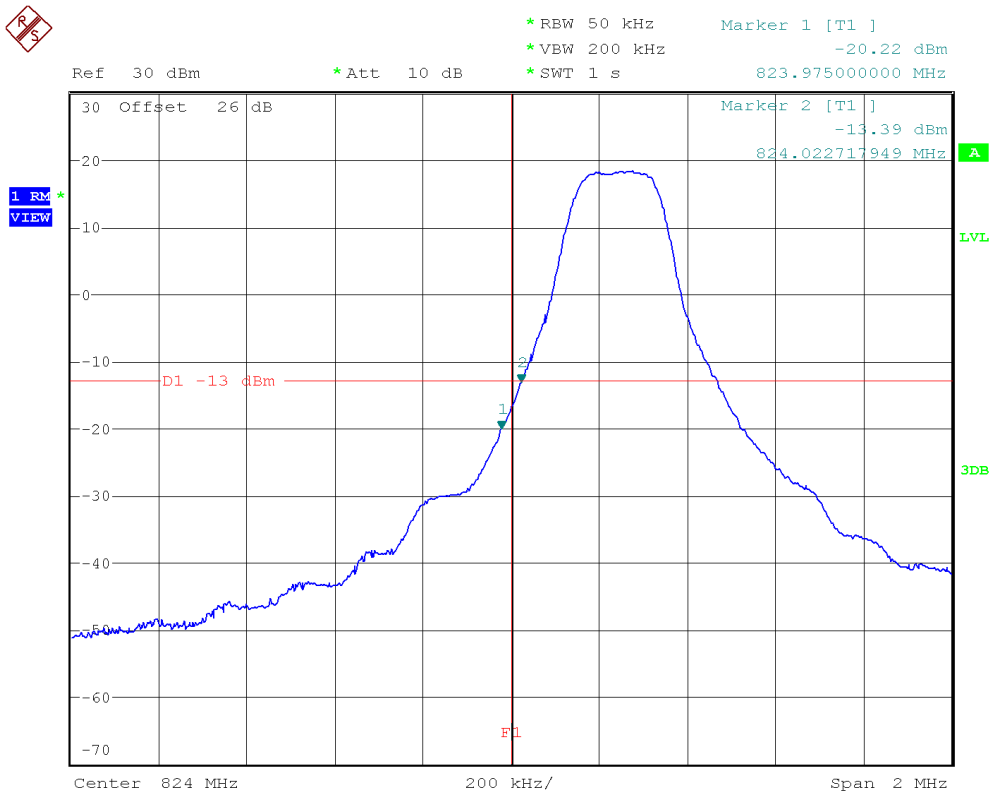

LTE Band 5. QPSK MODULATION. BW=3 MHz. RB=1. Offset=Max. Highest Block Edge:

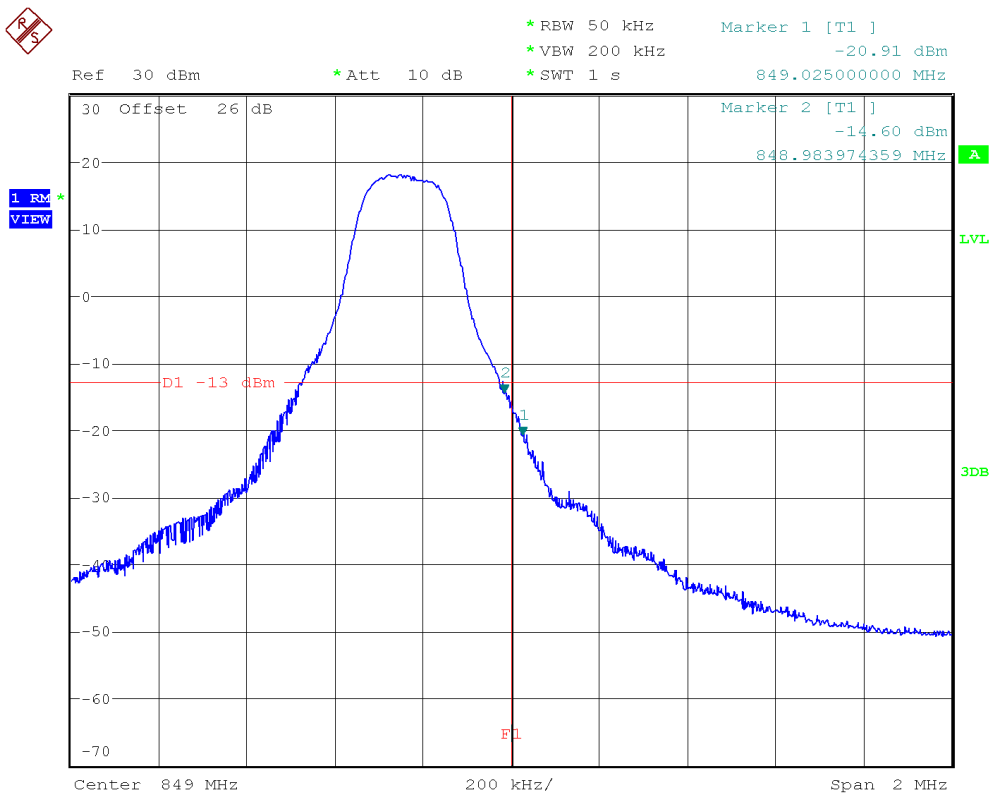

LTE Band 5. QPSK MODULATION. BW=3 MHz. RB=All. Offset=0. Lowest and Highest Block Edges:

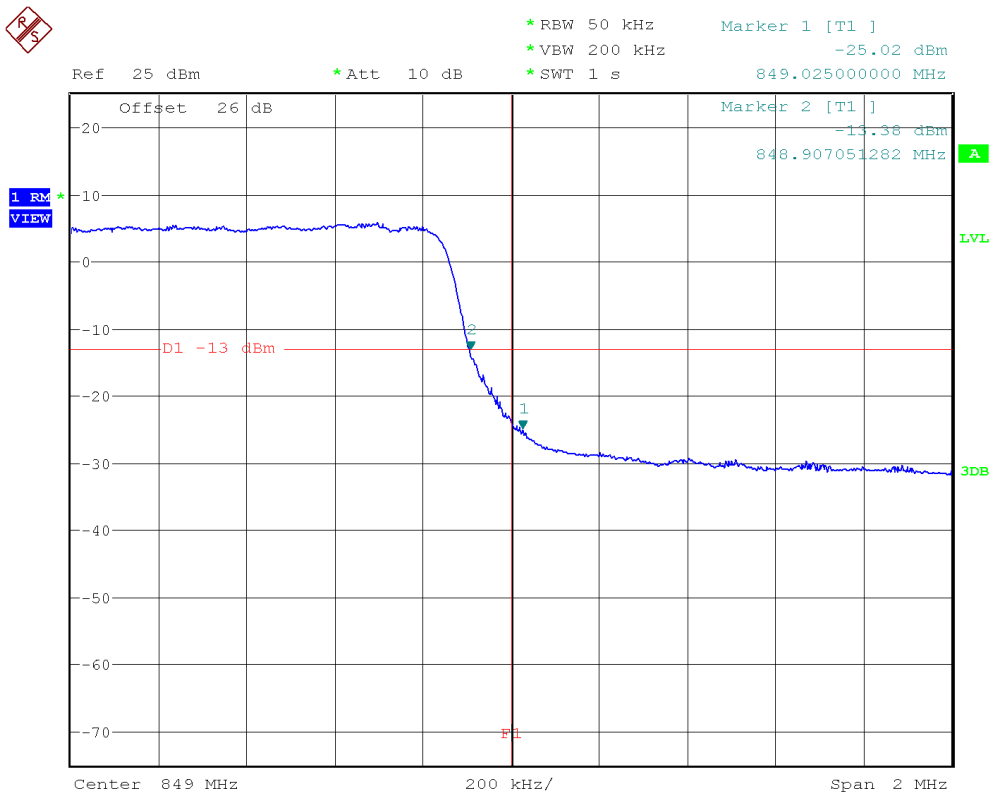
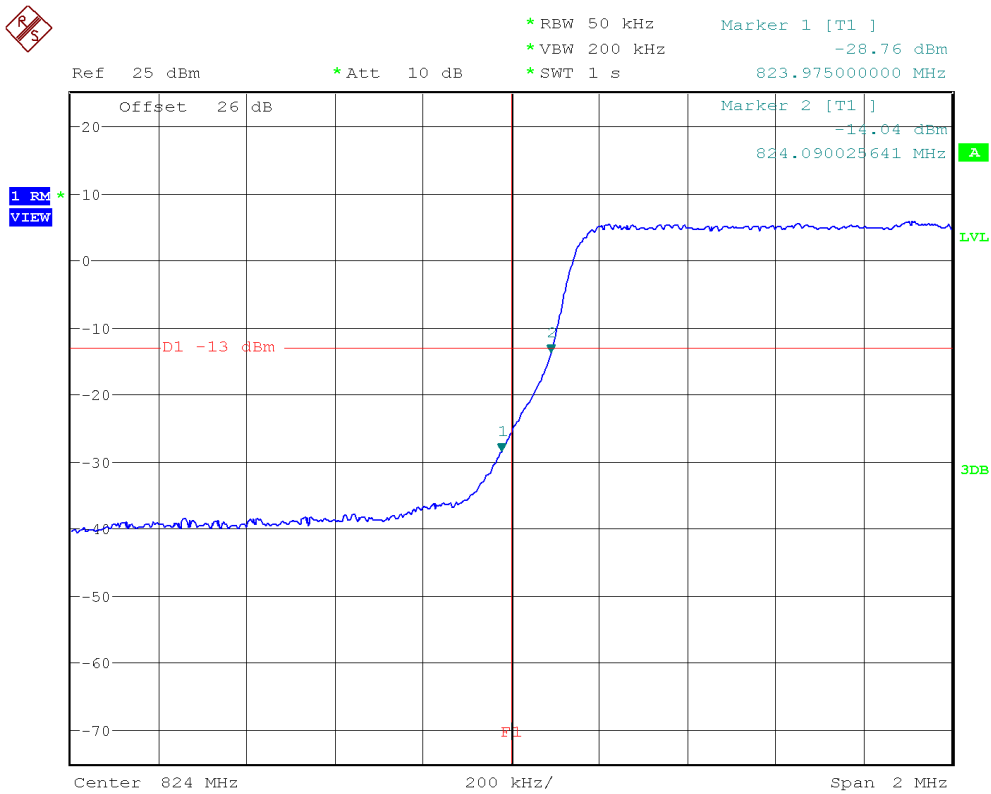

LTE Band 5. QPSK MODULATION. BW=5 MHz. RB=1. Offset=0. Lowest Block Edge:

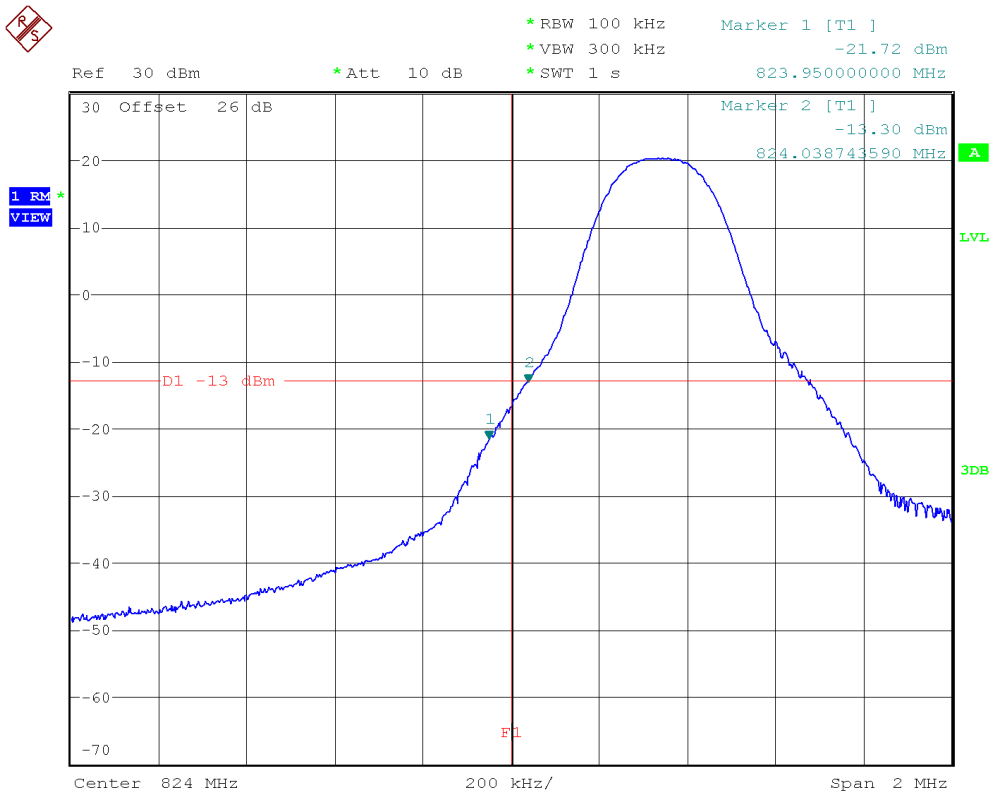

LTE Band 5. QPSK MODULATION. BW=5 MHz. RB=1. Offset=Max. Highest Block Edge:

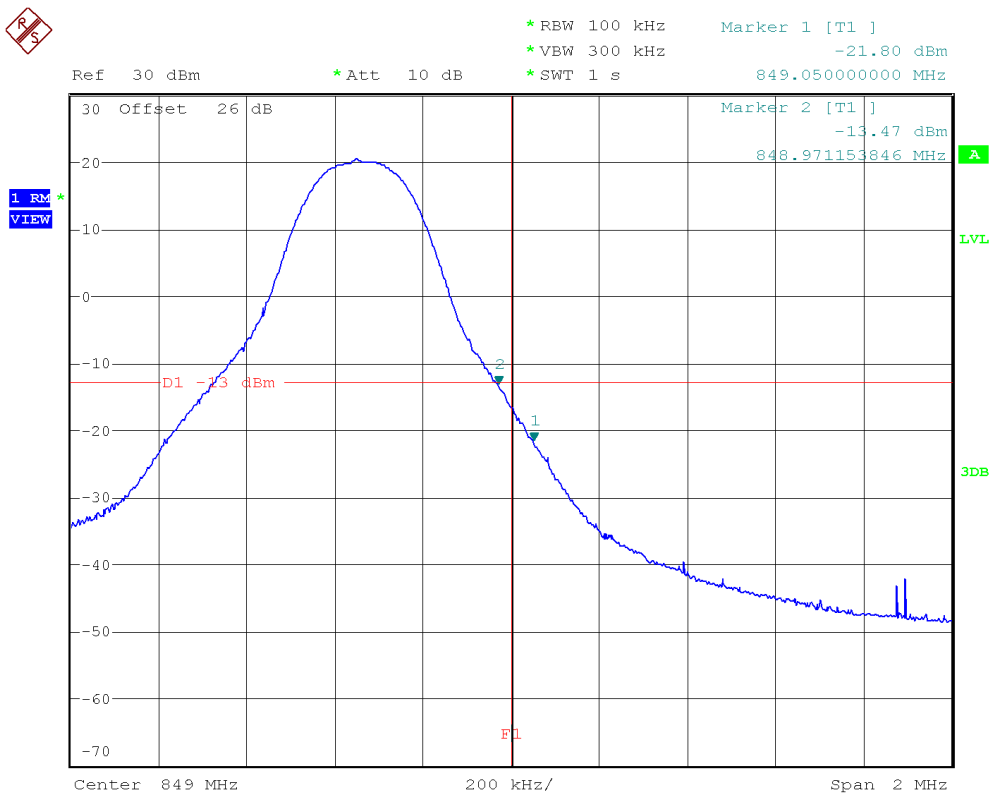

LTE Band 5. QPSK MODULATION. BW=5 MHz. RB=All. Offset=0. Lowest and Highest Block Edges:

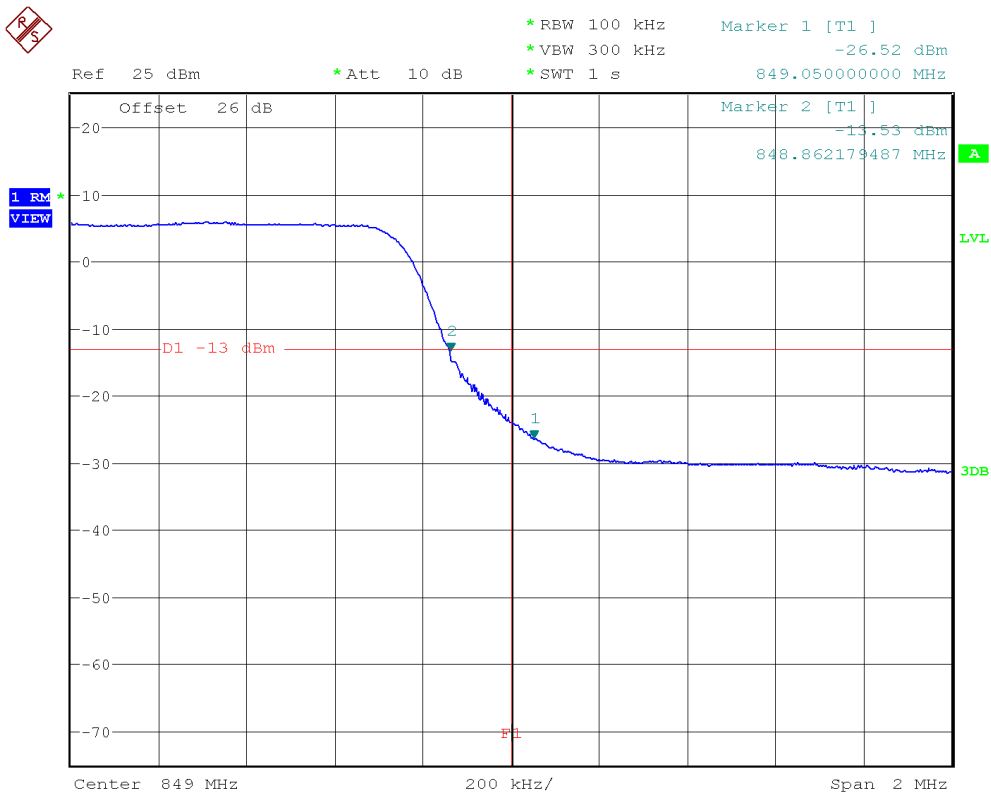
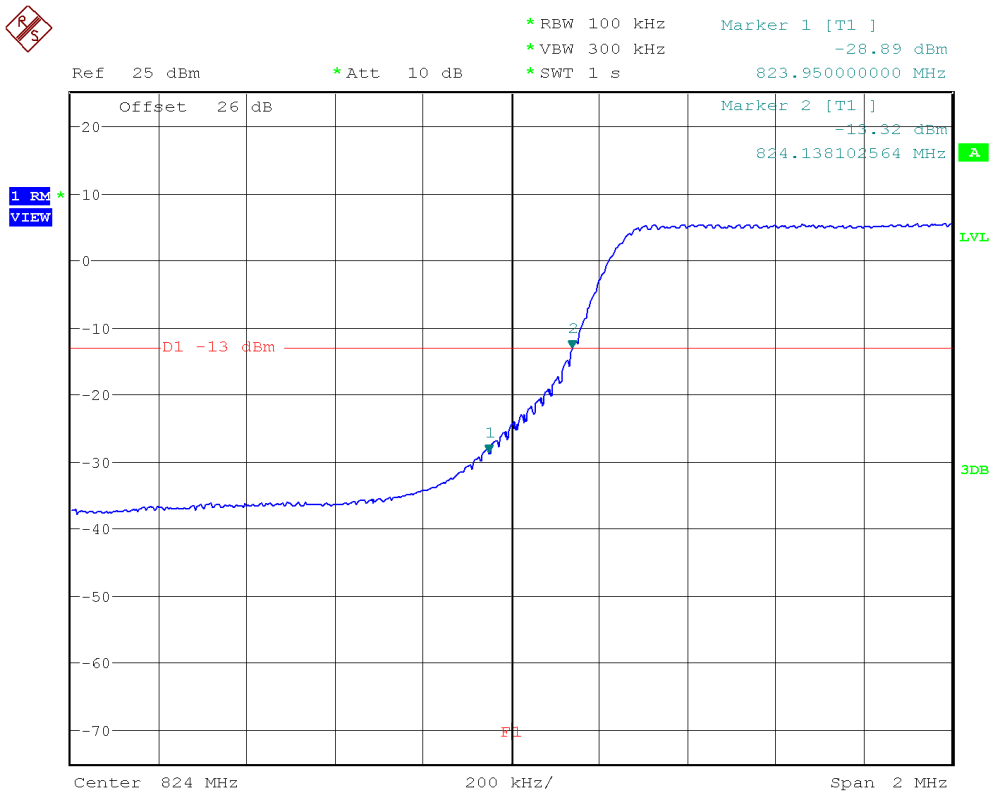

LTE Band 5. QPSK MODULATION. BW=10 MHz. RB=1. Offset=0. Lowest Block Edge:

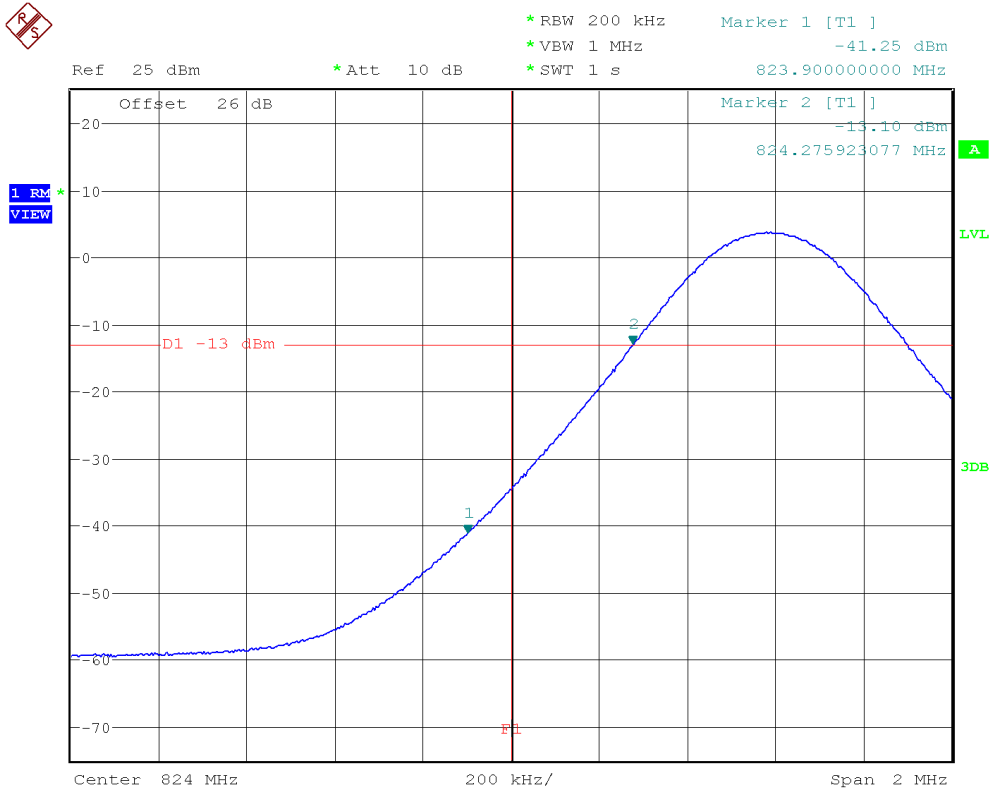

LTE Band 5. QPSK MODULATION. BW=10 MHz. RB=1. Offset=Max. Highest Block Edge:

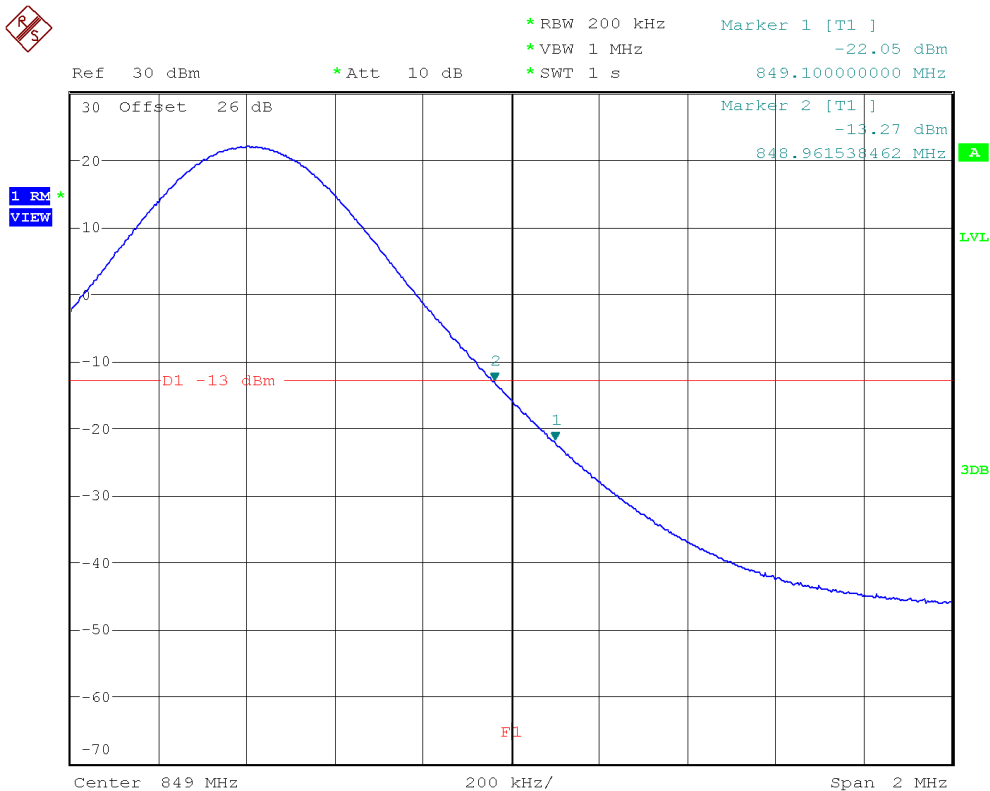

LTE Band 5. QPSK MODULATION. BW=10 MHz. RB=All. Offset=0. Lowest and Highest Block Edges:

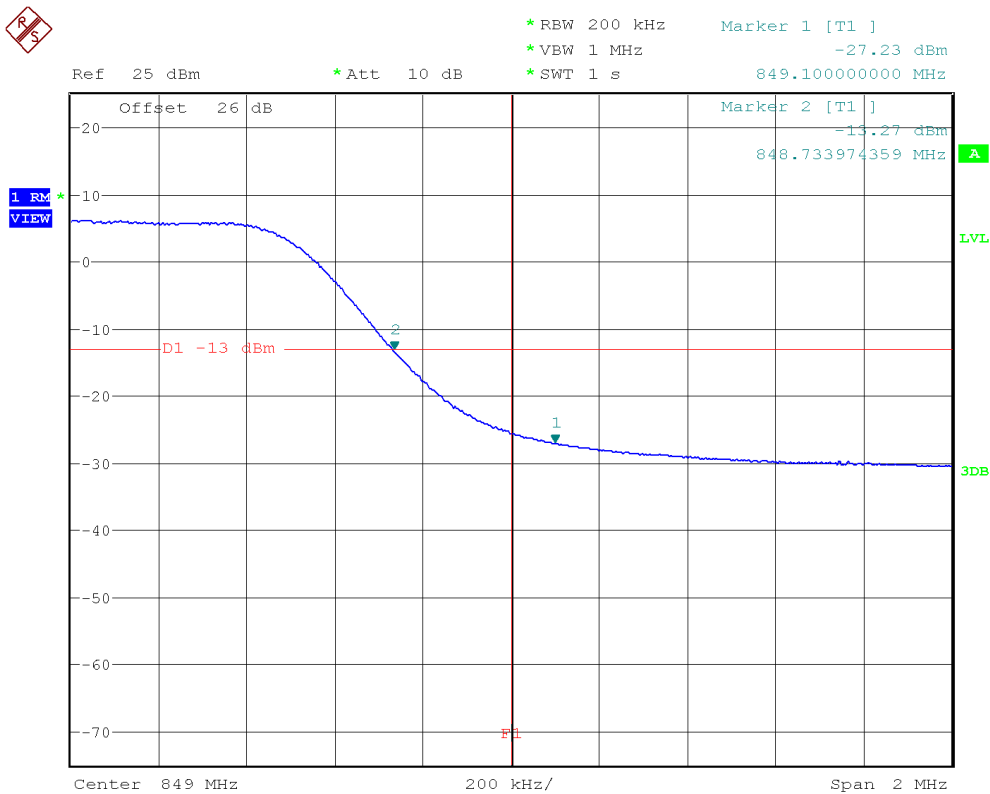
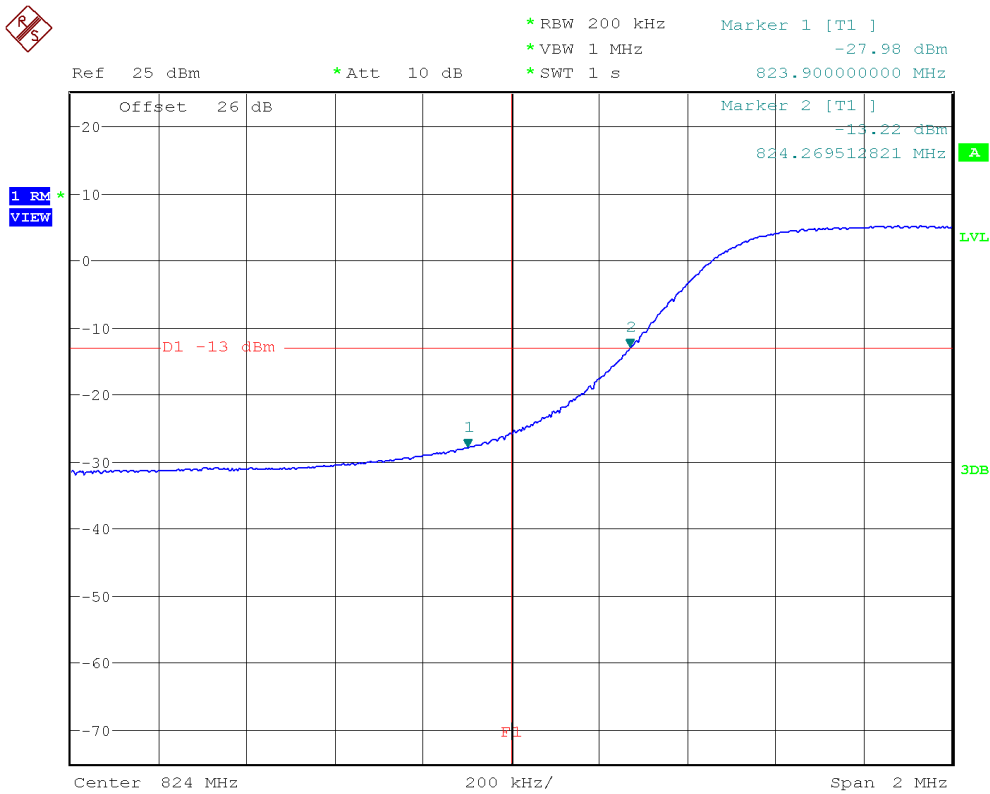

Radiated emissions

SPECIFICATION:

FCC §22.917:

RSS-132. Clause 5.5:

The power of emissions shall be attenuated below the transmitter power (P) by a factor of at least $43 + 10 \log (P)$ dB. P in watts.

METHOD:

The measurement was performed with the EUT inside an anechoic chamber.

The spectrum was scanned from 30 MHz to at least the 10th harmonic of the highest frequency generated within the equipment.

The EUT was placed on a non-conductive stand at a 3 meter distance from the measuring antenna for measurements below 1 GHz and at 1 m distance for measurements above 1 GHz.

Detected emissions were maximized at each frequency by rotating the EUT and adjusting the measuring antenna height and polarization. The maximum meter reading was recorded.

Each detected emission at less than 20 dB respect to the limit is substituted by the Substitution method in accordance with the ANSI/TIA-603-E: 2016.

Measurement Limit:

According to specification. the power of emissions shall be attenuated below the transmitter power (P) by a factor of at least $43 + 10 \log (P)$ dB. P in watts.

At P_o transmitting power. the specified minimum attenuation becomes $43+10\log (P_o)$. and the level in dBm relative P_o becomes:

$$P_o \text{ (dBm)} - [43 + 10 \log (P_o \text{ in mwatts}) - 30] = - 13 \text{ dBm}$$

TEST SETUP:

Radiated measurements below 1 GHz.

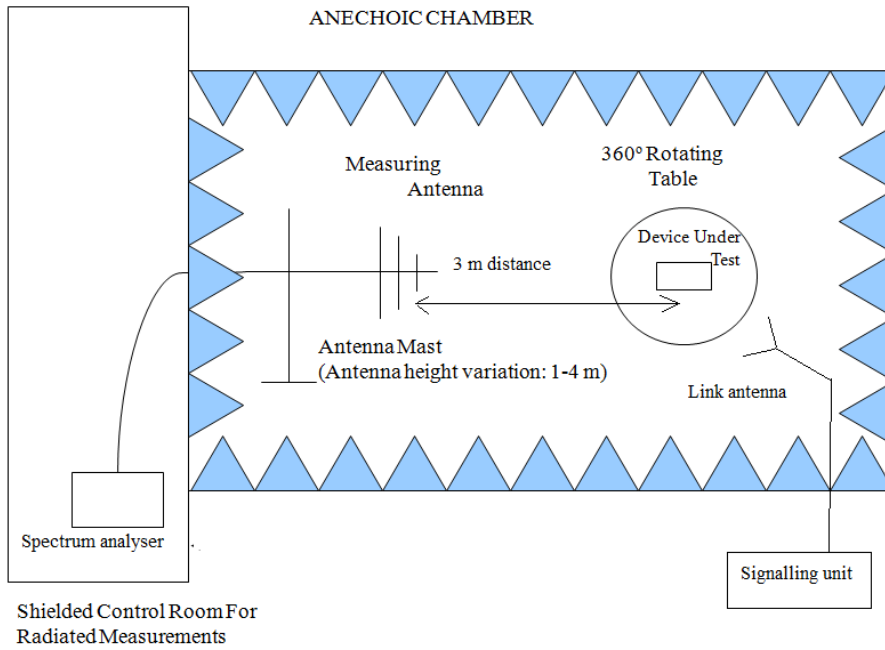

Radiated measurements above 1 GHz.

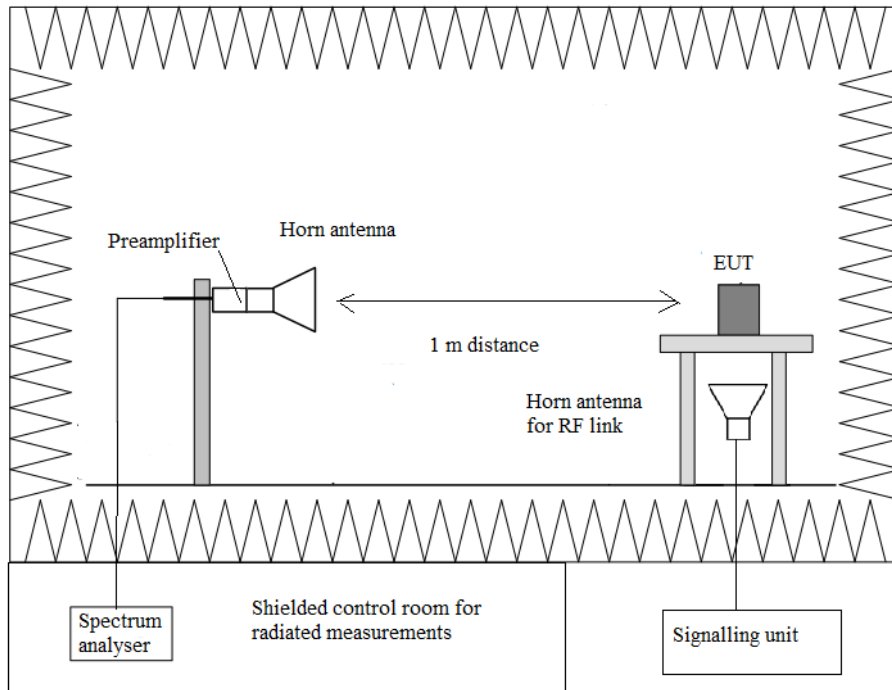

RESULTS:

3G Band V:

WCDMA and HSUPA Modulations:

A preliminary scan determined the WCDMA modulation as the worst case. The following tables and plots show the results for WCDMA modulation.

- Lowest Channel:

Frequency range 30 MHz - 1 GHz

No spurious frequencies detected at less than 20 dB below the limit.

Frequency range 1 - 10 GHz

No spurious frequencies detected at less than 20 dB below the limit.

- Middle Channel:

Frequency range 30 MHz - 1 GHz

No spurious frequencies detected at less than 20 dB below the limit.

Frequency range 1 - 10 GHz

Spurious frequencies detected at less than 20 dB below the limit:

Frequency (GHz)	Instrument reading (dBm)	Polarization	(1) Generator output (dBm)	(2) Cable loss (dB)	(3) Substitution antenna gain Gi (respect to isotropic radiator) (dB)	E.I.R.P. (dBm) = (1) – (2) + (3)
1.78375	-9.11	H	-28.45	0.9	9.19	-20.16

- Highest Channel:

Frequency range 30 MHz - 1 GHz

No spurious frequencies detected at less than 20 dB below the limit.

Frequency range 1 - 10 GHz

Spurious frequencies detected at less than 20 dB below the limit:

Spurious frequencies at less than 20 dB below the limit:

Frequency (GHz)	Instrument reading (dBm)	Polarization	(1) Generator output (dBm)	(2) Cable loss (dB)	(3) Substitution antenna gain Gi (respect to isotropic radiator) (dB)	E.I.R.P. (dBm) = (1) – (2) + (3)
1.78225	-15.26	H	-34.61	0.90	9.19	-26.32
1.94185	-21.10	V	-40.20	1.37	9.86	-31.71

FREQUENCY RANGE 30 MHz - 1 GHz

WCDMA MODULATION

- Lowest Channel:

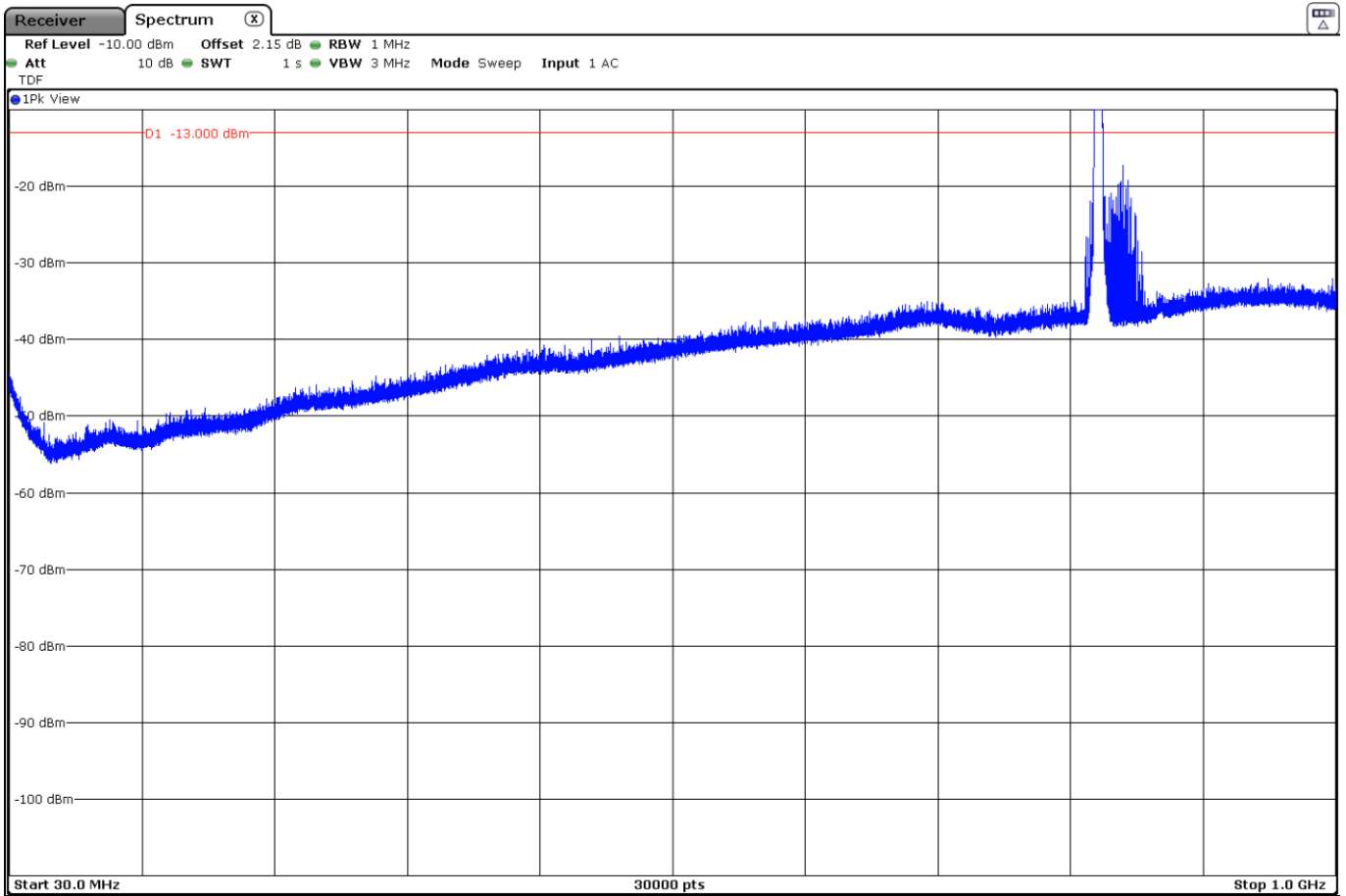

The peak above the limit is the carrier frequency.

- Middle Channel:

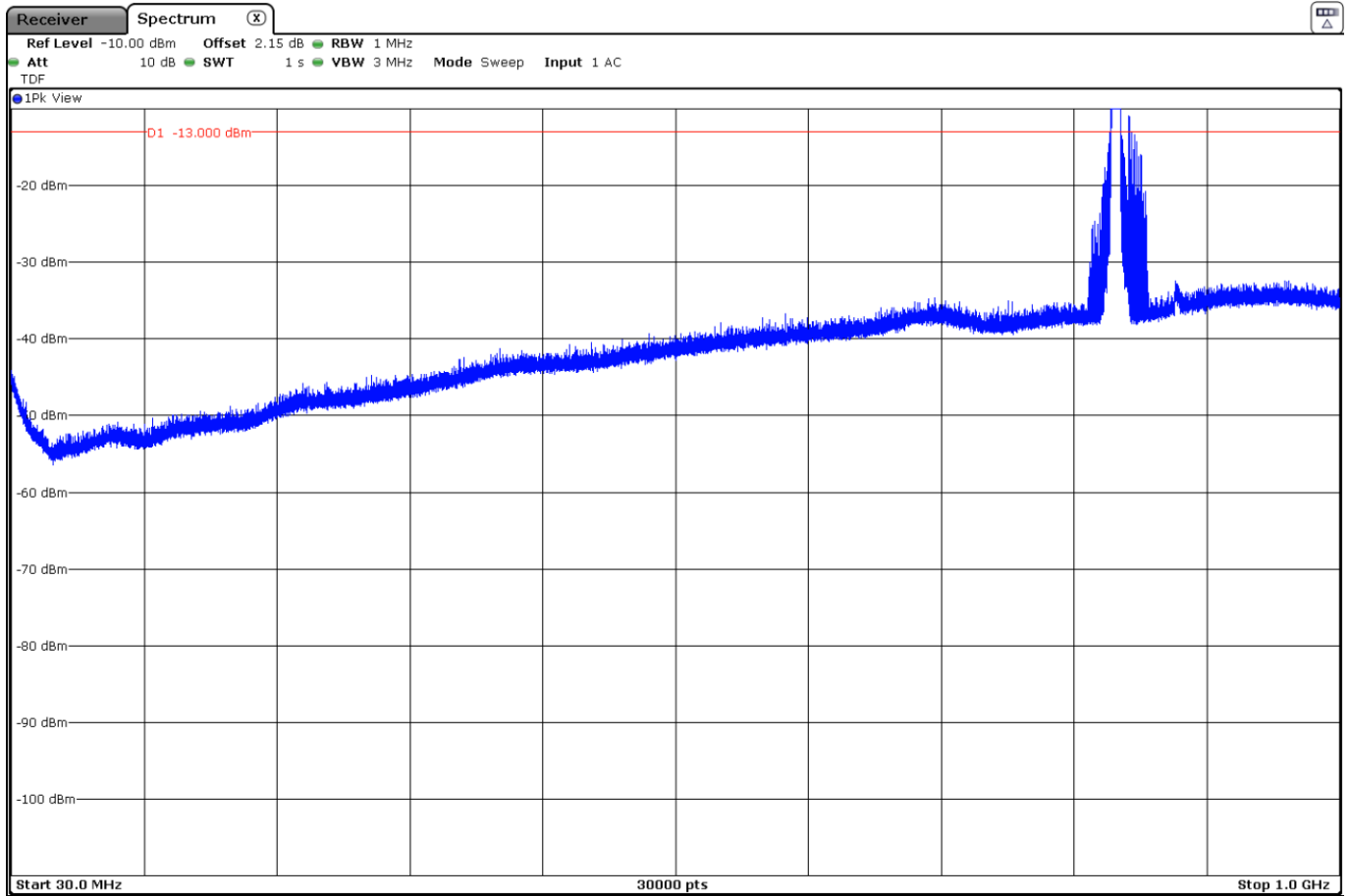

The peak above the limit is the carrier frequency.

- Highest Channel:

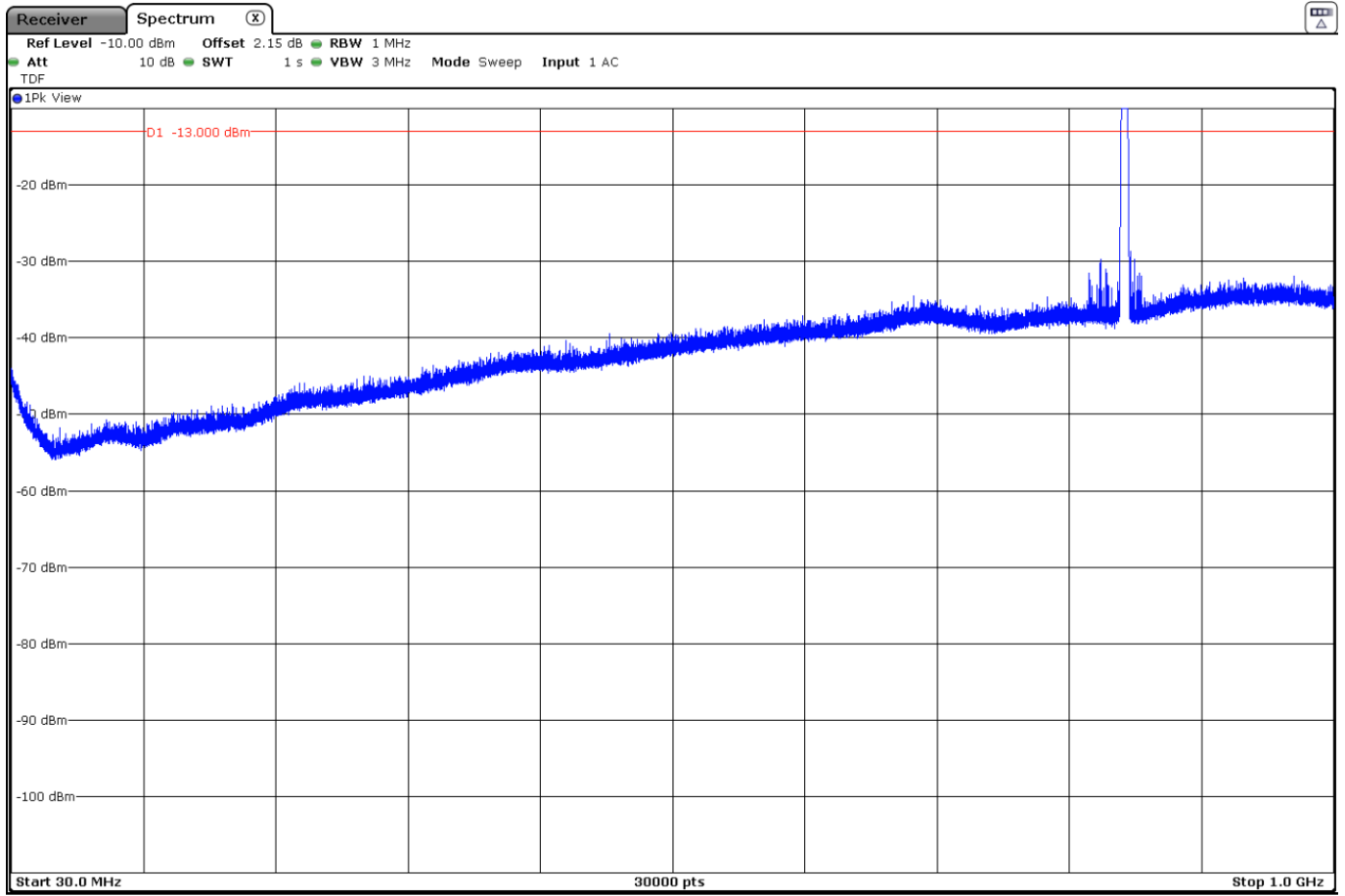

The peak above the limit is the carrier frequency.

FREQUENCY RANGE 1 - 10 GHz

WCDMA MODULATION

- Lowest Channel:

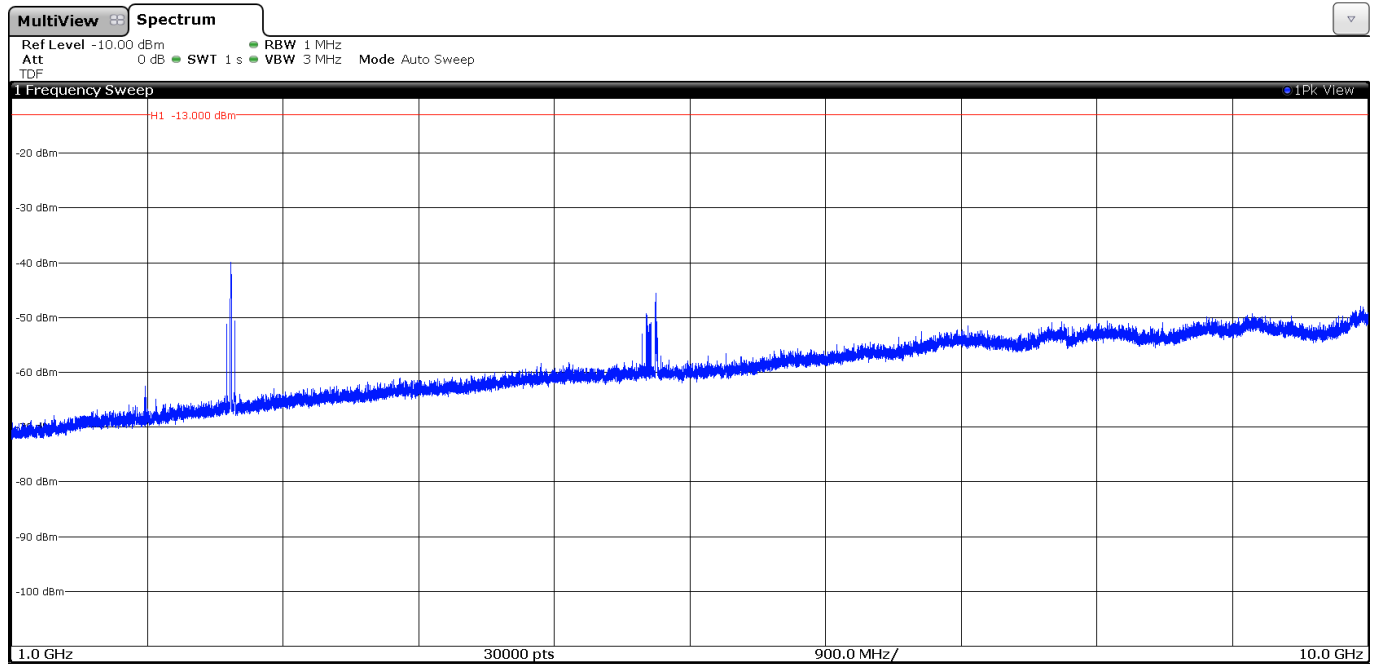

- Middle Channel:

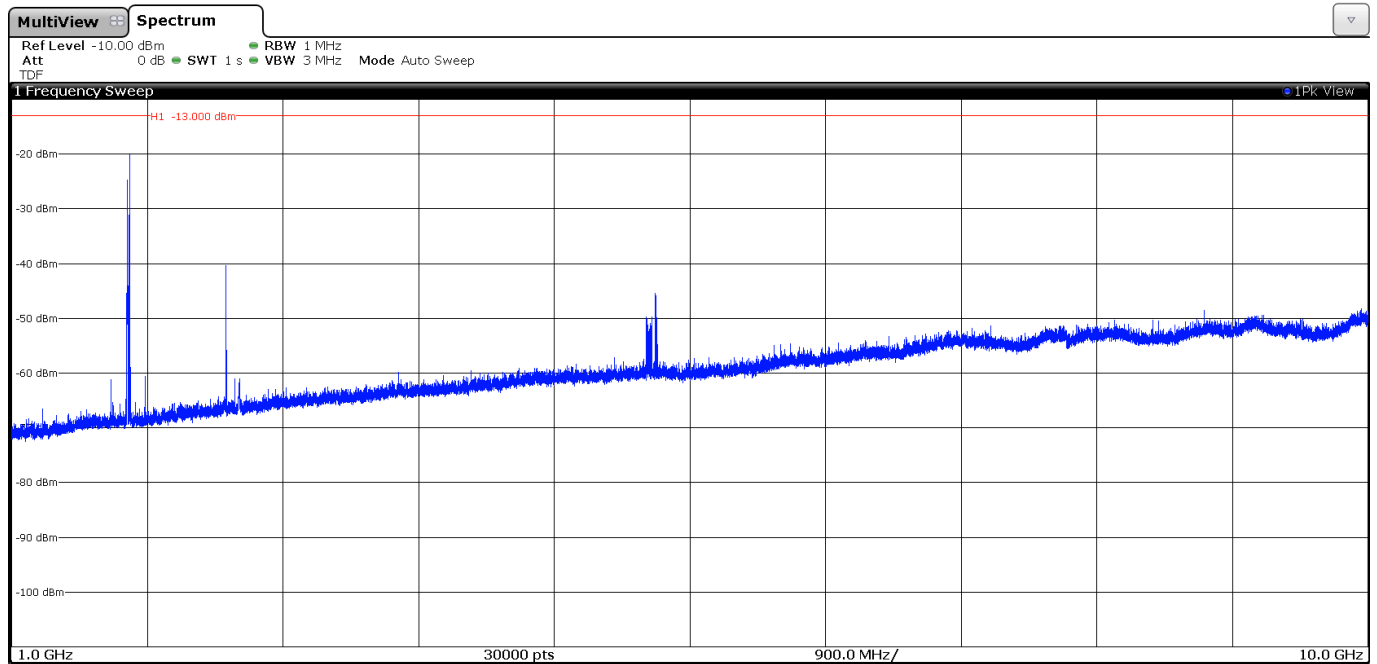

- Highest Channel:

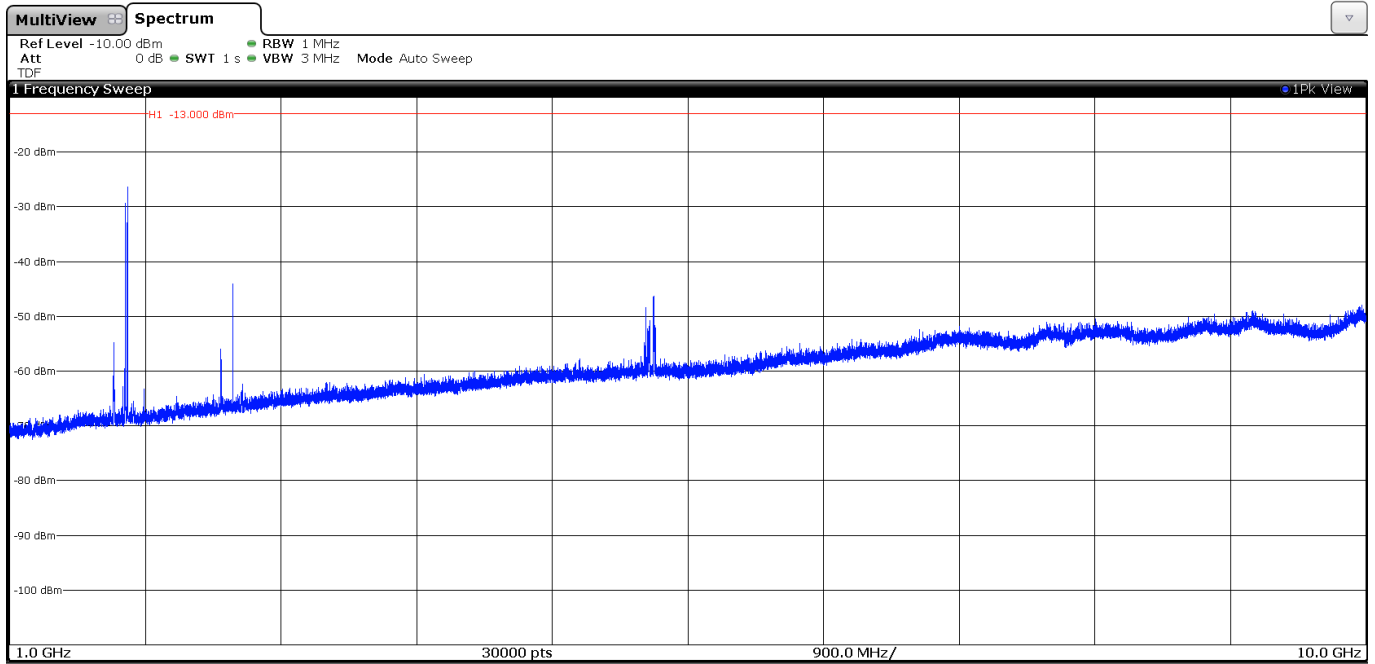

LTE Band 5:

QPSK and 16QAM Modulations:

A preliminary scan determined the QPSK modulation, BW=5 MHz, RB=1, Offset=12 as the worst case.

- Lowest Channel:

Frequency range 30 MHz - 1 GHz

No spurious frequencies at less than 20 dB below the limit.

Frequency range 1 - 8 GHz

No spurious frequencies at less than 20 dB below the limit.

- Middle Channel:

Frequency range 30 MHz - 1 GHz

No spurious frequencies at less than 20 dB below the limit.

Frequency range 1 - 8 GHz

No spurious frequencies at less than 20 dB below the limit.

- Highest Channel:

Frequency range 30 MHz - 1 GHz

No spurious frequencies at less than 20 dB below the limit.

Frequency range 1 - 8 GHz

No spurious frequencies at less than 20 dB below the limit.

Measurement uncertainty (dB)	<±2.07 for f < 1GHz <±4.88 for f ≥ 1 GHz up to 18 GHz
------------------------------	--

Verdict: PASS

FREQUENCY RANGE 30 MHz - 1 GHz

QPSK MODULATION

- Lowest Channel:

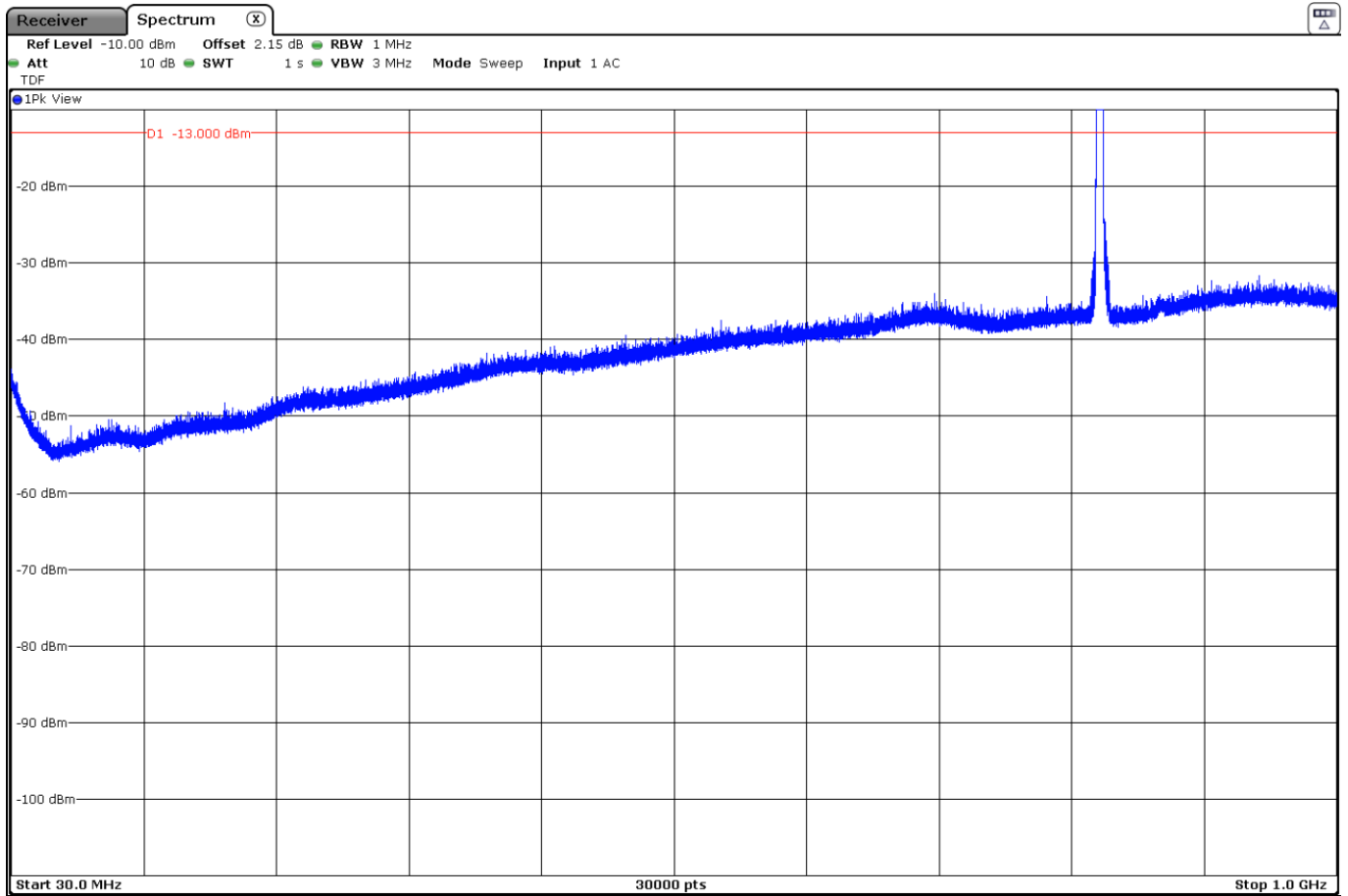

The peak above the limit is the carrier frequency:

- Middle Channel:

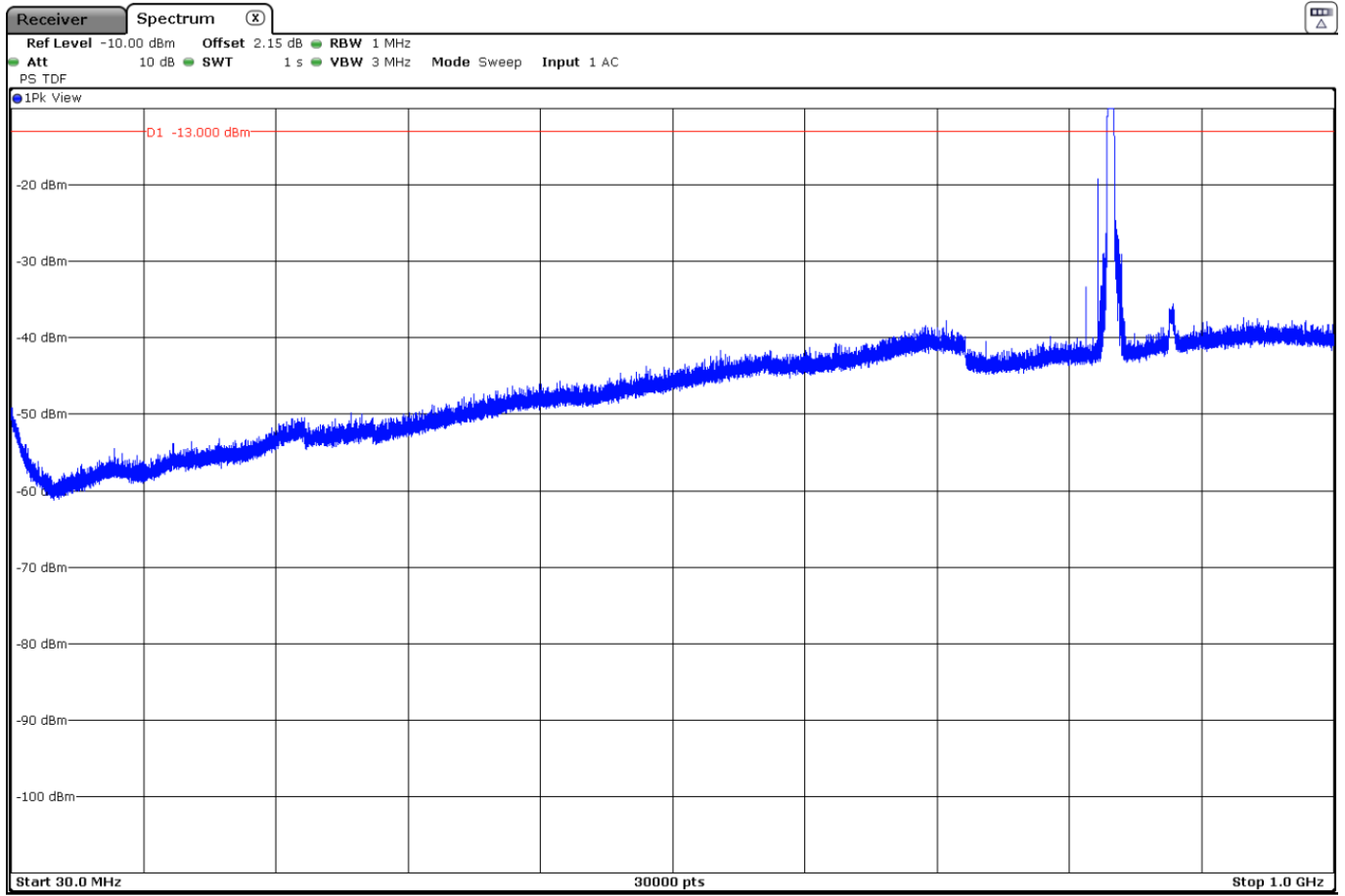

The peak above the limit is the carrier frequency:

- Highest Channel:

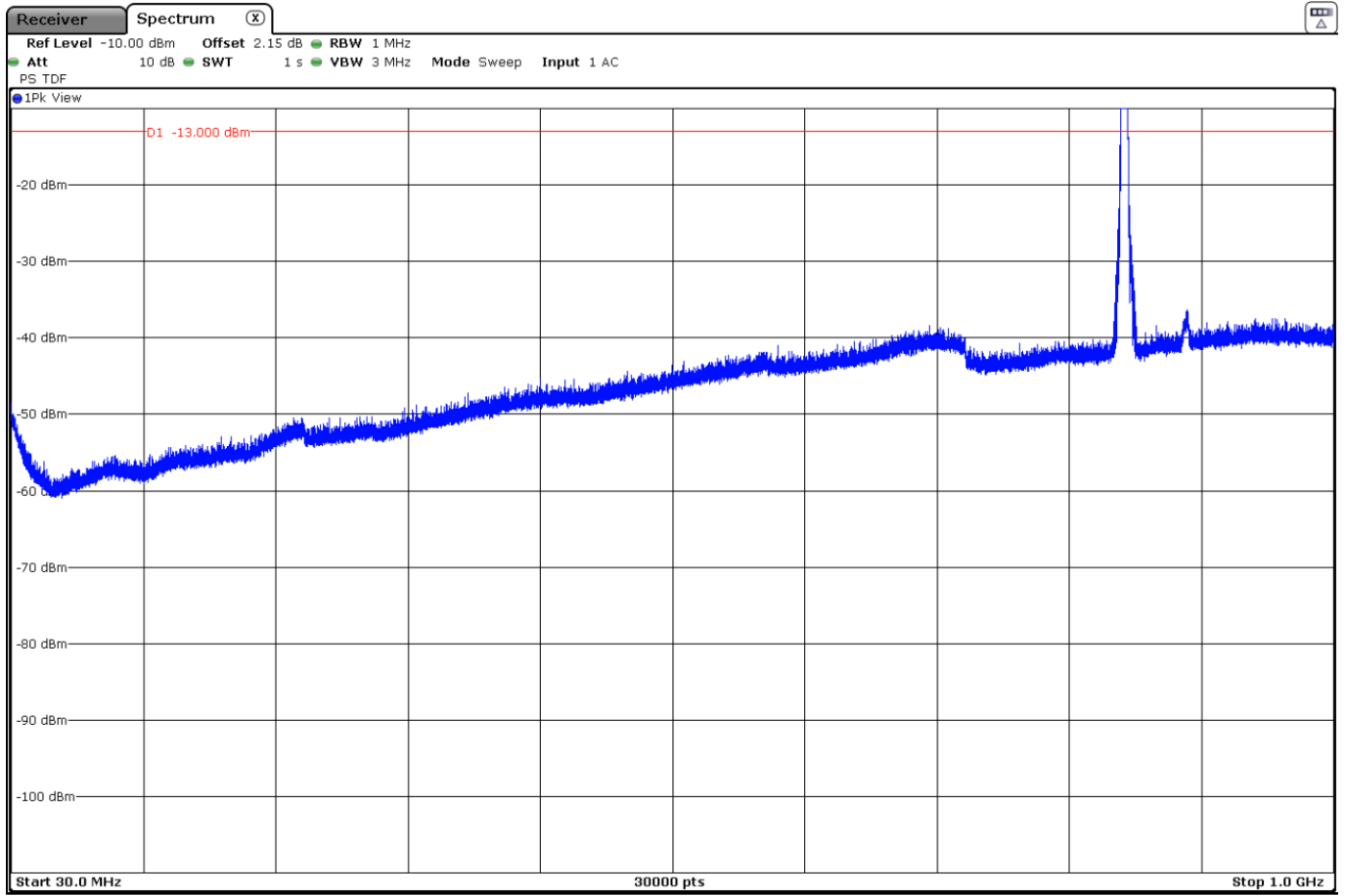

The peak above the limit is the carrier frequency:

FREQUENCY RANGE 1 - 10 GHz

QPSK MODULATION

- Lowest Channel:

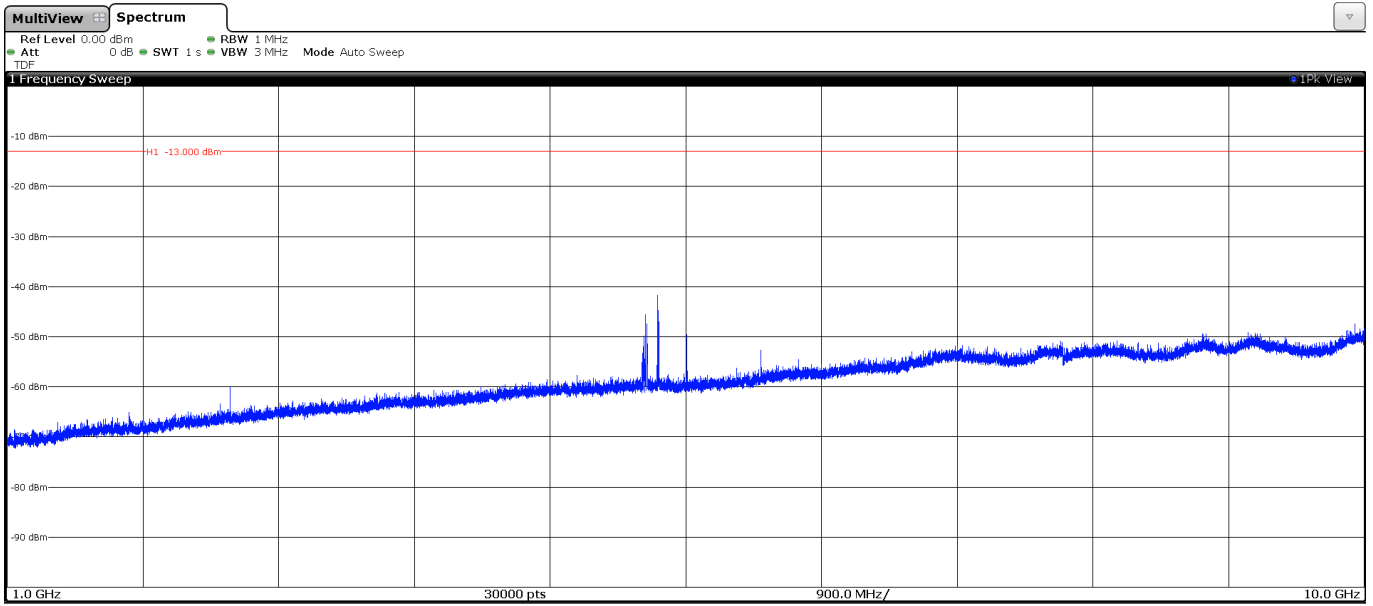

- Middle Channel:

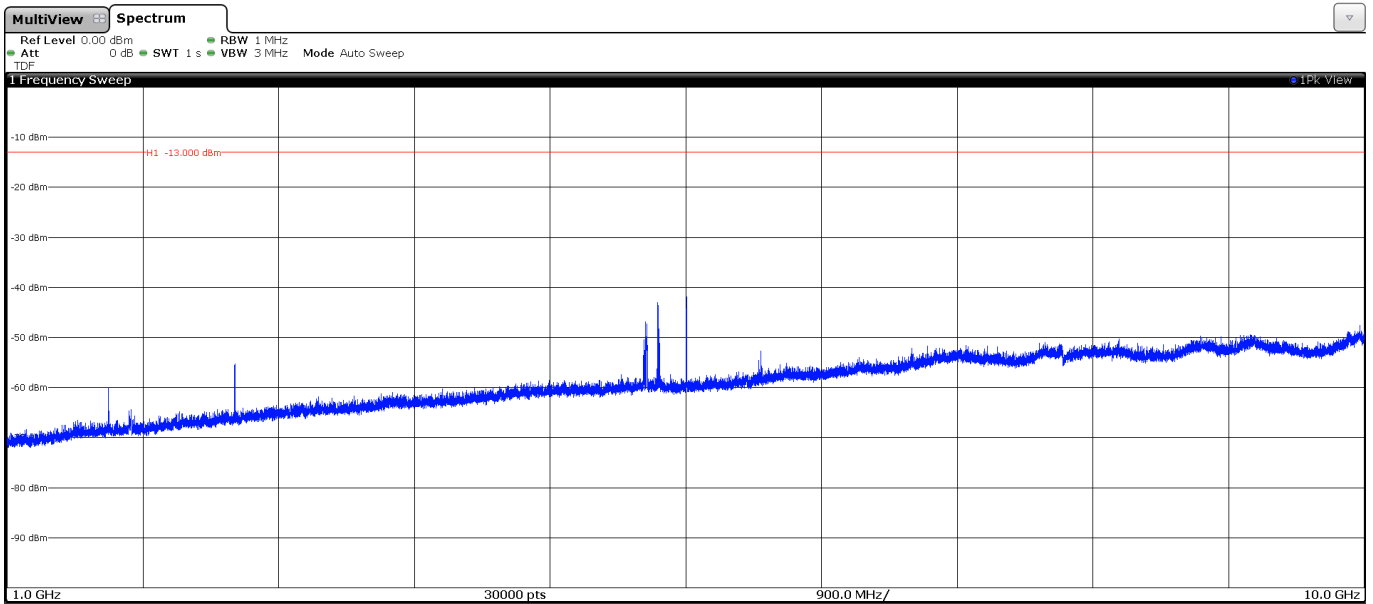

- Highest Channel:

