



CMM-10/CMM-10i

Marine Source Unit with LCD Display

OWNER'S MANUAL
 MANUEL D'UTILISATION
 MANUAL DEL PROPIETARIO
 BEDIENUNGSANLEITUNG
 MANUALE DEL PROPRIETARIO



CMM-10i only

Clarion



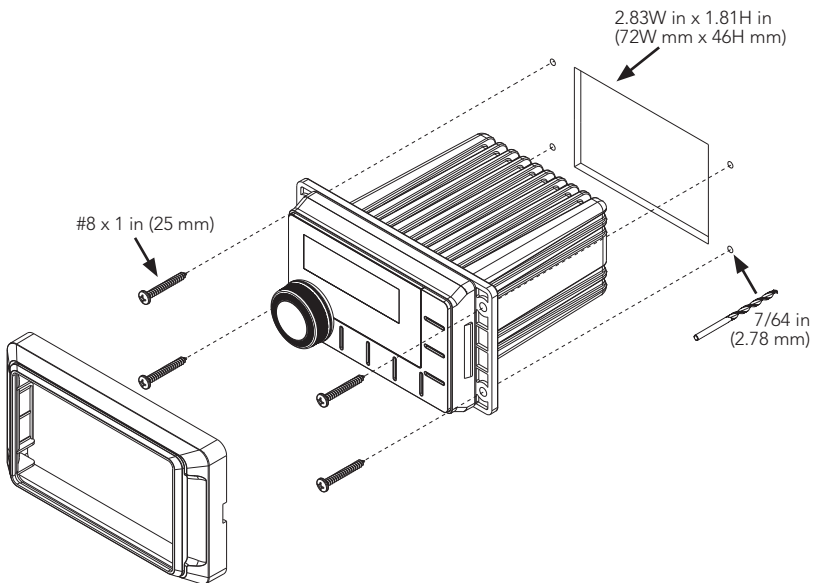
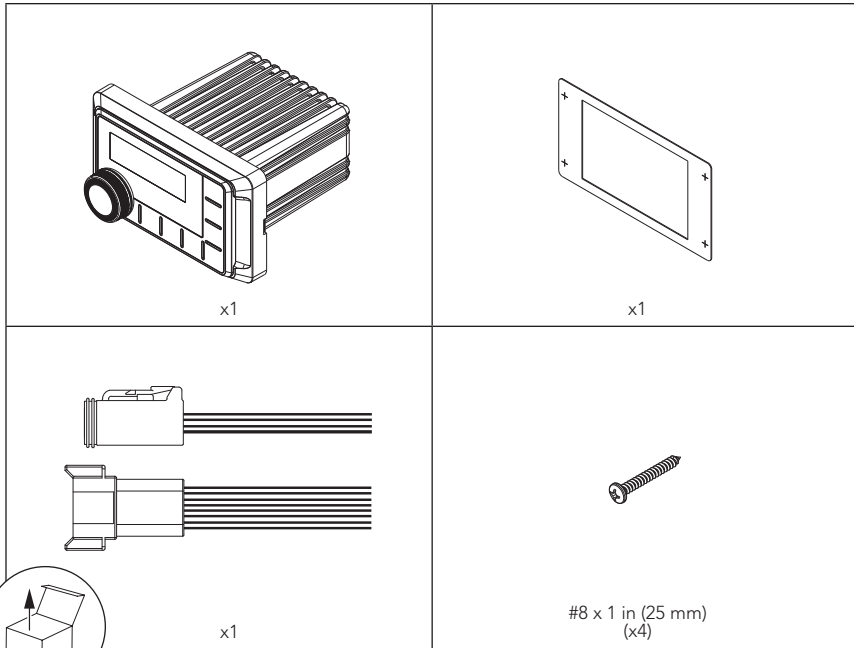

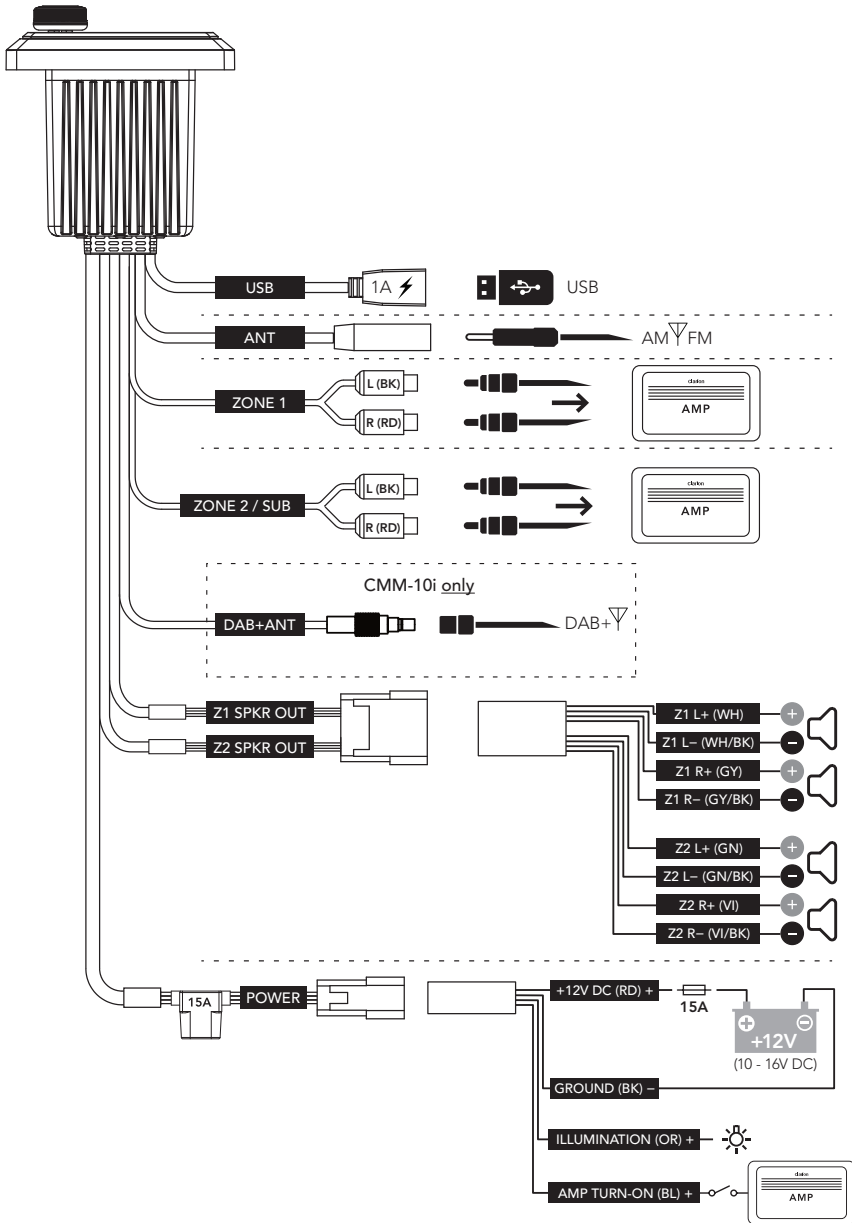



FCC COMPLIANCE STATEMENT

This device complies with Part 15 of the FCC Rules. Operation is subject to the following two conditions: (1) this device may not cause harmful interference, and (2) this device must not accept any interference received, including interference that may cause undesired operation. These limits are designed to provide reasonable protection against harmful interference in a residential installation.

This equipment generates, uses and can radiate radio frequency energy and, if not installed in accordance with the instructions, may cause harmful interference to radio communications. However, there is no guarantee that interference will not occur in a particular installation. If this equipment does cause harmful interference to radio or television reception, the user is encouraged to try to correct the interference by one or more of the following measures:

- Reorient or relocate the receiving antenna.
- Increase separation between the equipment and the receiver.
- Connect the equipment to an outlet on a circuit different from that to which the receiver is connected.
- Consult the dealer or an experienced radio/TV technician for help.

Any changes or modifications not expressly approved by the party responsible for compliance could void the user's authority to operate this equipment.

SAFETY CONSIDERATIONS

- Only use this product in vehicles with 12 volt, negative-ground electrical systems. This product is not certified or approved for use in aircraft.
- Mount this product securely to prevent damage or injury in severe conditions.
- Do not replace the power wire fuse with one of a different value. Never bypass the fuse.
- Listen to your audio system at levels appropriate for operating conditions and hearing safety.

INSTALLATION CONSIDERATIONS

- Installation requires appropriate tools and safety equipment. Professional installation is recommended.
- This product is water-resistant. Do not submerge or subject to high-pressure water spray.
- Before installation, turn off the audio system and disconnect the battery system from the audio system.
- Install in a dry, well-ventilated location that does not interfere with your factory-installed systems. If a dry environment is not available, a location that is not exposed to heavy splashing may be used.
- Before cutting or drilling, check for potential obstacles behind mounting surfaces.
- Carefully route all system wiring away moving parts and sharp edges; secure with cable ties or wire clamps and use grommets and loom where appropriate to protect from sharp edges.



GENERAL CONTROL FUNCTIONS

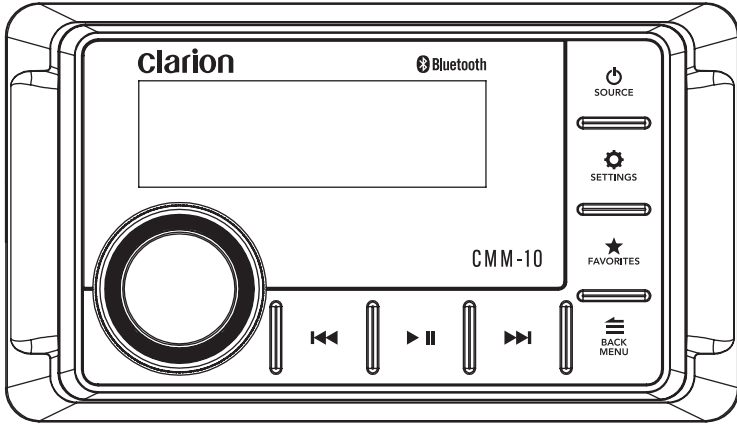

EN





Control		Function
	Volume/ Select	<ul style="list-style-type: none"> • Rotate to adjust volume • Rotate/press for navigation and making selections
	Source/ Power	<ul style="list-style-type: none"> • Short press to turn ON; Long press to turn OFF • Short press to advance through available sources
	Settings	<ul style="list-style-type: none"> • Short press to access audio settings (Bass/Treble/Balance/Fader) • Long press to access system settings (Z2-Sub/Beep/Area/Dimmer/Diagnostic)
	Back/ Menu	<ul style="list-style-type: none"> • Short press to go back one step or access source specific menus
	Favorites	<ul style="list-style-type: none"> • Short press to access stored presets • Long press to store a frequency as a preset (up to 9 FM, 9 AM and 9 DAB+)
	Mute/ Pause	<ul style="list-style-type: none"> • Short press to mute/unmute audio (AM/FM/DAB+) or pause/resume the current selection (USB/Bluetooth)
	Forward	Short press to: <ul style="list-style-type: none"> • Manually adjust tuner forwards (AM/FM/DAB+) • Select the next track (USB/Bluetooth) Long press to: <ul style="list-style-type: none"> • Seek to the next channel (AM/FM/DAB+) • Fast-forward (USB/Bluetooth)
	Backward	Short press to: <ul style="list-style-type: none"> • Manually adjust tuner backwards (AM/FM/DAB+) • Restart track/select the previous track (USB/Bluetooth) Long press to: <ul style="list-style-type: none"> • Seek to the previous channel (AM/FM/DAB+) • Fast-rewind (USB/Bluetooth)





SYSTEM MENU SETTINGS	
 SETTINGS	<ul style="list-style-type: none"> • Long press to access settings
	<ul style="list-style-type: none"> • Rotate to navigate • Press to make selections
Setting	Function
Z2/SUB	Configures preamp outputs: Z2 (rear) or Subwoofer
BEEP	Audible button press confirmation: On or Off
AREA	Configures tuner region: USA, Europe, Australia or Other
DIMMER	Configures display and button brightness from 0 to +10
DIAG	Displays software version for diagnostics



AUDIO MENU SETTINGS	
 SETTINGS	<ul style="list-style-type: none"> • Short press to access settings
	<ul style="list-style-type: none"> • Rotate to navigate • Press to make selections
Setting	Function
BASS	Bass level control from -10 to +10
TREBLE	Treble level control from -10 to +10
BALANCE	Balance control from full left (L10) to full right (R10)
FADER	Fader control from full front (Z1: 10) to full rear (Z2: 10)
SUB	Subwoofer preamp level control from 0 to +10 (Z2/SUB must be set to SUB)

FAVORITES MENU SETTINGS	
 FAVORITES	<ul style="list-style-type: none"> • Short press to access settings/stored presets • Long press to store a frequency as a preset (up to 9 FM, 9 AM and 9 DAB+)
	<ul style="list-style-type: none"> • Rotate to navigate • Press to make selections
Setting	Function
DELETE	Select from stored presets for removal
REPLACE	Permits replacement when all preset locations are occupied



EN

BLUETOOTH MENU SETTINGS	
 BACK/MENU	<ul style="list-style-type: none"> • Short press to access settings
	<ul style="list-style-type: none"> • Rotate to navigate • Press to make selections
Setting	Function
PAIR NEW DEVICE	Initiates Pairing Mode (current connected devices will be disconnected)
CONNECT PAIRED DEVICE	Display all paired devices for connection
SET PRIMARY DEVICE	Assign priority to a paired device for automatic connection
DELETE PAIRED DEVICE	Select from paired devices for removal
DELETE ALL DEVICES	Removes all paired devices from memory

USB MENU SETTINGS	
 BACK/MENU	<ul style="list-style-type: none"> • Short press to access settings
	<ul style="list-style-type: none"> • Rotate to navigate • Press to make selections
Setting	Function
RANDOM	Random playback of all tracks within all folders: On or Off
REPEAT	Repeats playback of the current track: On or Off
PLAY ALL	Plays all tracks within all folders: On or Off
FOLDERS	Displays folders within the USB
TRACKS	Displays tracks not located within a folder



SPECIFICATIONS

Electrical	
Operating Voltage	14.4V DC (10V – 16V)
Operating Temperature	–4° F to +95° F (–20° C to +35° C)
Current Draw / Fuse Value	15 A (max) / 40 mA (standby) / 15 A
Remote Turn-On Output	500 mA
Display	2.09 in. TFT LCD backlit
Tuner	
FM Tuner	USA: 87.9 MHz to 107.9 MHz (0.2 MHz step) EUR: 87.50 MHz to 108.00 MHz (0.05 MHz step) AUS: 87.50 MHz to 108.00 MHz (0.10 MHz step) OTHER: 87.50 MHz to 108.00 MHz (0.05 MHz step)
AM Tuner	USA: 530 kHz to 1710 kHz (10 kHz step) EUR: 531 kHz to 1602 kHz (9 kHz step) AUS: 531 kHz to 1629 kHz (9 kHz step) OTHER: 531 kHz to 1629 kHz (9 kHz step)
Favorites	Up to 9 FM, 9 AM and 9 DAB+
Bluetooth®	
Profile	5.0
Core Specification / Codec	Version 2.1 + EDR / SBC
Connection Range	Up to 35 ft / 11 m
USB	
Interface	USB 2.0 High Speed
Supported Audio Formats	MP3, WMA, FLAC, WAV
File Limits	Folders: 255 Files in a single folder: 3,000 Total Files: 9,999
Charging Output	1 A
Preamp Audio Outputs	
Output Channels	Two stereo pairs of RCA plugs (1.5V RMS)
Zone 2 Configuration	Z2 (Rear) or Subwoofer
Amplified Audio Outputs	
Rated RMS Power @ 14.4V	20W x 4 @ 4 Ω
Audio Control Options	
Tone & Balance	Bass, Treble, Balance, Fader (Zone 1 / Zone 2 or Subwoofer)
Dimensions	
Unit W x H x D	4.33 in. x 2.48 in. x 3.15 in. (110 mm x 63 mm x 80 mm)
Mounting Hole W x H	2.83 in. x 1.81 in. (72 mm x 46 mm)





RF exposure statement

This equipment complies with the FCC RF radiation exposure limits set forth for an uncontrolled environment. This equipment should be installed and operated with a minimum distance of 20cm between the radiator and any part of your body.

This equipment meets the exemption from the routine evaluation limits in section 2.5 of RSS-102. It should be installed and operated with a minimum distance of 20cm between the radiator and any part of your body.

Cet équipement est conforme à l'exemption des limites d'évaluation habituelle de la section 2.5 de la norme RSS-102. Il doit être installé et utilisé à une distance minimale de 20 cm entre le radiateur et toute partie de votre corps.

IC WARNING

This device contains licence-exempt transmitter(s) that comply with Innovation, Science and Economic Development Canada's licence-exempt RSS(s). Operation is subject to the following two conditions:

- (1) This device may not cause interference.
- (2) This device must accept any interference, including interference that may cause undesired operation of the device.

L'émetteur/récepteur exempt de licence contenu dans le présent appareil est conforme aux CNR d'Innovation, Sciences et Développement économique Canada applicables aux appareils radio exempts de licence. L'exploitation est autorisée aux deux conditions suivantes:

1. L'appareil ne doit pas produire de brouillage;
2. L'appareil doit accepter tout brouillage radioélectrique subi, même si le brouillage est susceptible d'en compromettre le fonctionnement.

Caution:

For the following equipment:

Product Name: Marine Source Unit

Brand Name: --

Model No.: CMM-10i, CMM-10

JL Audio, Inc.

E-mail: mphilipi@jlaudio.com

hereby declares that this [Name: Marine Source Unit, Model: CMM-10i, CMM-10] is in compliance with the essential requirements and other relevant provisions of Directive 2014/53/EU and Radio Equipment Regulations 2017 (SI 2017 No. 1206, as amended by SI 2019 No. 696).



This product is intended for sale and application in a business environment.

RED Article 10 2

-This product can be used across EU member states

RED Article 10 10

-The product is class 1 product, No restrictions

The RF distance between body and product is 0mm

Bluetooth

Bluetooth Version: Bluetooth V5.0(BR/EDR Mode)

Frequency Range: 2402MHz-2480MHz

Max.RF Output Power: 3.95dBm (EIRP)

AM

Frequency Range: 526.5-1606.5kHz Receiving

FM

Frequency Range: 87.5~108.0MHz Receiving

DAB

Frequency Range: 174-240MHz Receiving



DÉCLARATION DE COMPATIBILITÉ FCC

Cet appareil est conforme à la partie 15 des règles FCC. Son fonctionnement est soumis aux deux conditions suivantes :

(1) cet appareil ne doit pas causer d'interférences nuisibles, et (2) cet appareil doit tolérer les interférences reçues, y compris celles qui peuvent causer un fonctionnement non désiré.

Ces limites visent à garantir une protection raisonnable contre les interférences nuisibles d'une installation domestique.

Cet appareil génère, utilise et peut émettre de l'énergie radio électrique et, s'il n'est pas installé et utilisé conformément aux instructions, peut causer des interférences nuisibles aux communications radio. Cependant, rien ne garantit que des interférences ne se produiront pas dans une installation particulière. Si cet appareil provoque des interférences nuisibles avec la réception des signaux de radio ou de télévision, qui peuvent être vérifiés en éteignant et en rallumant l'appareil, l'utilisateur est encouragé à essayer de corriger ce problème en prenant une ou plusieurs des mesures suivantes :

- réorienter ou repositionner l'antenne de réception.
- augmenter la séparation entre l'appareil et le récepteur.
- brancher l'appareil sur un circuit électrique différent de celui où le récepteur est branché.
- consulter le revendeur ou un technicien radio/TV expérimenté pour une assistance.

Tout changement ou toute modification non approuvé expressément par la partie responsable de la conformité peut annuler l'autorisation de l'utilisateur à utiliser cet équipement.

CONSIDÉRATIONS RELATIVES À LA SÉCURITÉ :

- Utilisez ce produit uniquement sur des véhicules équipés de systèmes électriques de 12 V mis à la terre négative. Ce produit n'est ni certifié ni approuvé pour une utilisation en avion.
- Fixez solidement ce produit pour éviter tout risque de dommages ou de blessures graves.
- Ne remplacez pas le fusible du câble d'alimentation par un fusible d'une autre valeur. Ne contournez jamais le fusible.
- Écoutez votre système audio à un volume adapté aux conditions de fonctionnement et à votre audition.

CONSIDÉRATIONS RELATIVES À L'INSTALLATION

- L'installation nécessite des outils et des équipements de sécurité appropriés. Une installation par un professionnel est recommandée.
- Ce produit résiste à l'eau. Ne l'immergez pas ou ne le soumettez pas à un jet d'eau à haute pression.
- Avant l'installation, éteignez le système audio et débranchez la batterie de ce dernier.
- Installez le produit dans un endroit sec et bien ventilé qui n'interfère pas avec vos systèmes installés en usine. En l'absence d'environnement sec, installez-le dans un endroit qui n'est pas exposé à de fortes projections.
- Avant de procéder au découpage ou au perçage, vérifiez l'absence d'obstacles potentiels derrière les surfaces de montage.
- Éloignez soigneusement tous les câbles des pièces mobiles et des bords tranchants. Fixez-les à l'aide d'attaches ou de serre-câbles et utilisez des passe-câbles et des faisceaux de câbles, le cas échéant, pour les protéger des bords tranchants.

FONCTIONS DE COMMANDE GÉNÉRALES

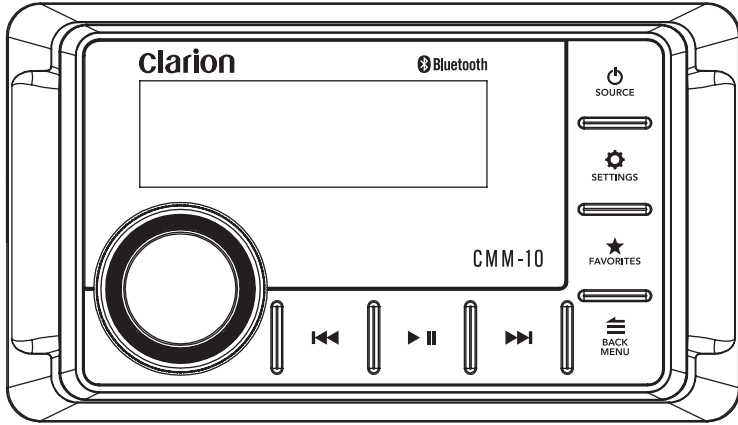



FR



Commande		Fonction
	Volume/ Select	<ul style="list-style-type: none"> • Tourner pour régler le volume • Tourner/appuyer pour naviguer et effectuer des sélections
	Source/ Power	<ul style="list-style-type: none"> • Appuyer brièvement pour allumer l'appareil ; appuyer longtemps pour l'éteindre • Appuyer brièvement pour faire défiler les sources disponibles
	Settings	<ul style="list-style-type: none"> • Appuyer brièvement pour accéder aux paramètres audio (Basses/Aigus/Balance/Atténuateur) • Appuyer longtemps pour accéder aux paramètres système (Z2-Sub/Bip/Zone/Variateur/Diagnostic)
	Back/ Menu	<ul style="list-style-type: none"> • Appuyer brièvement pour revenir à l'étape précédente ou accéder à des menus spécifiques de la source
	Favorites	<ul style="list-style-type: none"> • Appuyer brièvement pour accéder aux présélections enregistrées • Appuyer longtemps pour enregistrer une fréquence comme présélection (jusqu'à 9 FM, 9 AM et 9 DAB+)
	Mute/ Pause	<ul style="list-style-type: none"> • Appuyer brièvement pour couper/rétablir le son (AM/FM/DAB+) ou mettre en pause/reprendre la sélection en cours (USB/Bluetooth)
	Forward	<p>Appuyer brièvement pour :</p> <ul style="list-style-type: none"> • Faire défiler le tuner en avant manuellement (AM/FM/DAB+) • Sélectionner la piste suivante (USB/Bluetooth) <p>Appuyer longtemps pour :</p> <ul style="list-style-type: none"> • Rechercher le canal suivant (AM/FM/DAB+) • Effectuer une avance rapide (USB/Bluetooth)
	Backward	<p>Appuyer brièvement pour :</p> <ul style="list-style-type: none"> • Faire défiler le tuner en arrière manuellement (AM/FM/DAB+) • Redémarrer la piste/sélectionner la piste précédente (USB/Bluetooth) <p>Appuyer longtemps pour :</p> <ul style="list-style-type: none"> • Rechercher le canal précédent (AM/FM/DAB+) • Effectuer un retour en arrière rapide (USB/Bluetooth)





PARAMÈTRES DU MENU SYSTÈME

 SETTINGS	<ul style="list-style-type: none">• Appuyer longuement pour accéder aux paramètres
	<ul style="list-style-type: none">• Tourner pour naviguer• Appuyer pour effectuer des sélections
Paramètre	Fonction
Z2/SUB	Configurer les sorties du préampli : Z2 (arrière) ou Subwoofer
BEEP	Confirmation sonore de la pression des boutons : activé ou désactivé
AREA	Configurer la région du tuner : États-Unis, Europe, Australie ou Autre
DIMMER	Configurer la luminosité de l'écran et des boutons de 0 à +10
DIAG	Afficher la version du logiciel à des fins de diagnostic

PARAMÈTRES DU MENU AUDIO

 SETTINGS	<ul style="list-style-type: none">• Appuyer brièvement pour accéder aux paramètres
	<ul style="list-style-type: none">• Tourner pour naviguer• Appuyer pour effectuer des sélections
Paramètre	Fonction
BASS	Régler les basses de -10 à +10
TREBLE	Régler les aigus de -10 à +10
BALANCE	Régler la balance de totalement à gauche (L10) à totalement à droite (R10)
FADER	Commande de l'atténuateur depuis totalement à l'avant (Z1 : 10) à totalement à l'arrière (Z2 : 10)
SUB	Commande du niveau de préamplification du subwoofer de 0 à +10 (Z2/SUB doit être réglé sur SUB)



PARAMÈTRES DU MENU FAVORIS



 FAVORITES	<ul style="list-style-type: none">• Appuyer brièvement pour accéder aux paramètres/présélections enregistrées• Appuyer longuement pour enregistrer une fréquence comme présélection (jusqu'à 9 FM, 9 AM et 9 DAB+)
	<ul style="list-style-type: none">• Tourner pour naviguer• Appuyer pour effectuer des sélections
Paramètre	Fonction
DELETE	Sélectionner les présélections enregistrées à supprimer
REPLACE	Autoriser le remplacement lorsque tous les emplacements prédéfinis sont occupés





FR

PARAMÈTRES DU MENU BLUETOOTH	
 BACK/MENU	<ul style="list-style-type: none"> • Appuyer brièvement pour accéder aux paramètres
	<ul style="list-style-type: none"> • Tourner pour naviguer • Appuyer pour effectuer des sélections
Paramètre	Fonction
PAIR NEW DEVICE	Lancer le mode d'appariement (les appareils actuellement connectés seront déconnectés)
CONNECT PAIRED DEVICE	Afficher tous les appareils appariés pour la connexion
SET PRIMARY DEVICE	Attribuer une priorité à un appareil apparié pour la connexion automatique
DELETE PAIRED DEVICE	Sélectionner les appareils appariés à supprimer
DELETE ALL DEVICES	Supprimer de la mémoire tous les appareils appariés

PARAMÈTRES DU MENU USB	
 BACK/MENU	<ul style="list-style-type: none"> • Appuyer brièvement pour accéder aux paramètres
	<ul style="list-style-type: none"> • Tourner pour naviguer • Appuyer pour effectuer des sélections
Paramètre	Fonction
RANDOM	Lire de manière aléatoire toutes les pistes de tous les dossiers : activé ou désactivé
REPEAT	Répéter la lecture de la piste en cours : activé ou désactivé
PLAY ALL	Lire toutes les pistes de tous les dossiers : activé ou désactivé
FOLDERS	Afficher les dossiers de la clé USB
TRACKS	Afficher les pistes qui ne se trouvent pas dans un dossier



CARACTÉRISTIQUES

Spécifications électriques	
Tension de fonctionnement	14,4 V CC (10 V - 16 V)
Température de fonctionnement	(-20 °C à +35 °C (-4° F à +95 °F))
Consommation de courant / Valeur du fusible	15 A (max.) / 40 mA (veille) / 15 A
Sortie de mise sous tension à distance	500 mA
Écran	53 mm (2,09 po) TFT LCD rétro-éclairé
Tuner	
Tuner FM	USA : 87,9 MHz à 107,9 MHz (pas de 0,2 MHz) EUR : 87,50 MHz à 108 MHz (pas de 0,05 MHz) AUS : 87,50 MHz à 108 MHz (pas de 0,10 MHz) AUTRE : 87,50 MHz à 108 MHz (pas de 0,05 MHz)
Tuner AM	USA : 530 kHz à 1 710 kHz (pas de 10 kHz) EUR : 531 kHz à 1 602 kHz (pas de 9 kHz) AUS : 531 kHz à 1 629 kHz (pas de 9 kHz) AUTRE : 531 kHz à 1 629 kHz (pas de 9 kHz)
Favoris	Jusqu'à 9 FM, 9 AM et 9 DAB+
Bluetooth®	
Profil	5.0
Spécification de base / Codec	Version 2.1 + EDR / SBC
Portée de la connexion	Jusqu'à 11 m (35 pi)
USB	
Interface	USB 2.0 haut débit
Formats audio pris en charge	MP3, WMA, FLAC, WAV
Limites pour les fichiers	Dossiers : 255 Fichiers dans un dossier : 3 000 Nombre total de fichiers : 9 999
Sortie de charge	1 A
Sorties audio du préampli	
Canaux de sortie	Deux paires stéréo de fiches RCA (1,5 V RMS)
Configuration de la zone 2	Z2 (arrière) ou Subwoofer
Sorties audio amplifiées	
Puissance RMS nominale à 14,4 V	20 W x 4 à 4 Ω
Options des commandes audio	
Tonalité et balance	Basses, aigus, balance, atténuateur (Zone 1 / Zone 2 ou Subwoofer)
Dimensions	
Récepteur L x H x P	110 mm x 63 mm x 80 mm (4,33 po x 2,48 po x 3,15 po)
Orifice de montage L x H	72 mm x 46 mm (2,83 po x 1,81 po)





FR





DECLARACIÓN DE CUMPLIMIENTO CON LA FCC

Este dispositivo cumple con la parte 15 de las normas de la FCC (Comisión Federal de Comunicaciones de los Estados Unidos). Su funcionamiento está sujeto a las dos condiciones siguientes:

- (1) este dispositivo no puede causar interferencias perjudiciales, y
- (2) este dispositivo no debe aceptar ninguna interferencia recibida, incluidas las que puedan provocar un funcionamiento no deseado.

Dichos límites tienen como fin proporcionar protección razonable contra interferencias perjudiciales en una instalación residencial.

Este equipo genera, usa y puede irradiar energía de radiofrecuencia y, en caso de no ser instalado conforme a las instrucciones, puede ocasionar interferencias perjudiciales para las comunicaciones por radio. No obstante, no existe garantía de que no se produzcan interferencias en una instalación en particular. Si este equipo genera interferencias perjudiciales en la recepción de señales de radio o televisión, se recomienda al usuario que intente corregir las interferencias mediante una o más de las siguientes medidas:

- Reoriente o reubique la antena receptora.
- Aumente la separación entre el equipo y el receptor.
- Conecte el equipo en una salida de un circuito diferente de aquel al cual está conectado el receptor.
- Consulte con el distribuidor o con un técnico experimentado en radios/televisores para obtener ayuda.

Cualquier cambio o modificación no aprobado expresamente por la parte responsable del cumplimiento podría anular la autoridad del usuario para utilizar este equipo.

IFETEL AVISO

La operación de este equipo está sujeta a las siguientes dos condiciones:

- (1) es posible que este equipo o dispositivo no cause interferencia perjudicial y
- (2) este equipo o dispositivo debe aceptar cualquier interferencia, incluyendo la que pueda causar su operación no deseada.

CONSIDERACIONES RELATIVAS A LA SEGURIDAD

- Utilice este producto únicamente en vehículos con sistemas eléctricos de 12 V con toma de tierra negativa. Este producto no está certificado ni aprobado para su uso en aeronaves.
- Monte este producto de forma segura para evitar daños o lesiones en condiciones extremas.
- No sustituya el fusible del cable de alimentación por uno de diferente valor. No puentee nunca el fusible.
- Escuche el sistema de audio a un volumen adecuado, teniendo en cuenta las condiciones de funcionamiento y la seguridad auditiva.

CONSIDERACIONES SOBRE LA INSTALACIÓN

- Para la instalación se requieren herramientas y equipos de seguridad adecuados. Se recomienda que la instalación la realice un profesional.
- Este producto es resistente al agua. No se debe sumergir ni rociar con agua a alta presión.
- Antes de la instalación, apague el sistema de audio y desconecte el sistema de batería del sistema de audio.
- Instálelo en un lugar seco y bien ventilado que no interfiera con los sistemas instalados de fábrica. Si no se dispone de un entorno seco, puede utilizarse un lugar que no esté expuesto a fuertes salpicaduras.
- Antes de cortar o taladrar, compruebe que no haya obstáculos detrás de las superficies de montaje.
- Coloque cuidadosamente todo el cableado del sistema lejos de piezas móviles y de bordes afilados; asegúrelo con flejes o abrazaderas para cables y utilice pasacables y protectores de mazos de cables cuando sea necesario para protegerlo de los bordes afilados.

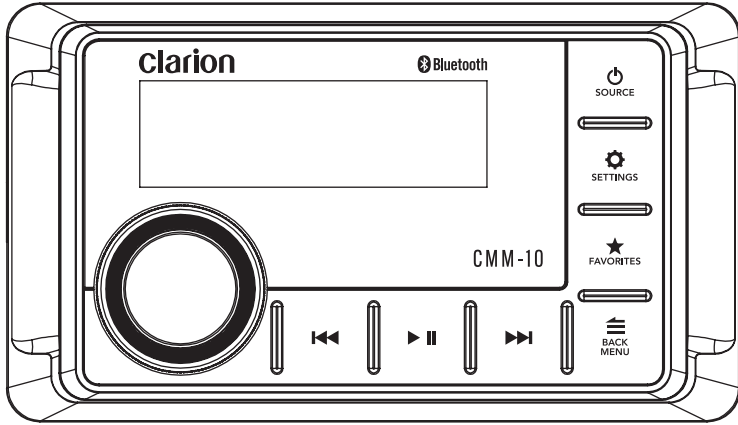

FUNCIONES GENERALES DE CONTROL





ES

Control		Función
	Volume/ Select	<ul style="list-style-type: none"> • Girar para ajustar el volumen • Girar/presionar para navegar y seleccionar
	Source/ Power	<ul style="list-style-type: none"> • Presionar brevemente para encender; mantener presionado para apagar • Presionar brevemente para cambiar entre las fuentes disponibles
	Settings	<ul style="list-style-type: none"> • Presionar brevemente para acceder a los ajustes de audio (bajos/agudos/balance/atenuador) • Mantener presionado para acceder a los ajustes del sistema (Z2-Sub/bip/área/regulador/diagnóstico)
	Back/ Menu	<ul style="list-style-type: none"> • Presionar brevemente para regresar al menú anterior o acceder a los menús específicos de la fuente
	Favorites	<ul style="list-style-type: none"> • Presionar brevemente para acceder a las frecuencias memorizadas • Mantener presionado para guardar una frecuencia como favorita en la memoria (máx. 9 en FM, 9 en AM y 9 en DAB+)
	Mute/ Pause	<ul style="list-style-type: none"> • Presionar brevemente para silenciar/reactivar el audio (AM/FM/DAB+) o pausar/reanudar la selección actual (USB/Bluetooth)
	Forward	<p>Presionar brevemente para:</p> <ul style="list-style-type: none"> • Ajustar manualmente el sintonizador hacia delante (AM/FM/DAB+) • Seleccionar la siguiente pista (USB/Bluetooth) <p>Mantener presionado para:</p> <ul style="list-style-type: none"> • Buscar el siguiente canal (AM/FM/DAB+) • Avanzar rápidamente (USB/Bluetooth)
	Backward	<p>Presionar brevemente para:</p> <ul style="list-style-type: none"> • Ajustar manualmente el sintonizador hacia atrás (AM/FM/DAB+) • Reiniciar la pista/seleccionar la pista anterior (USB/Bluetooth) <p>Mantener presionado para:</p> <ul style="list-style-type: none"> • Buscar el canal anterior (AM/FM/DAB+) • Retroceder rápidamente (USB/Bluetooth)



AJUSTES DEL MENÚ DEL SISTEMA	
 SETTINGS	<ul style="list-style-type: none"> Mantener presionado para acceder a los ajustes
	<ul style="list-style-type: none"> Girar para navegar Presionar para seleccionar
Ajuste	Función
Z2/SUB	Configura las salidas del preamplificador: Z2 (atrás) o subwoofer
BEEP	Confirmación sonora al presionar botones: encendida o apagada
AREA	Configura la región del sintonizador: Estados Unidos, Europa, Australia u otra
DIMMER	Configura el brillo de la pantalla y los botones entre 0 y +10
DIAG	Muestra la versión de software para el diagnóstico

AJUSTES DEL MENÚ DE AUDIO	
 SETTINGS	<ul style="list-style-type: none"> Presionar brevemente para acceder a los ajustes
	<ul style="list-style-type: none"> Girar para navegar Presionar para seleccionar
Ajuste	Función
BASS	Control del nivel de graves entre -10 y +10
TREBLE	Control del nivel de agudos entre -10 y +10
BALANCE	Control del balance entre todo a la izquierda (L10) y todo a la derecha (R10)
FADER	Control del atenuador entre todo el sonido a la parte delantera (Z1: 10) y todo a la parte trasera (Z2: 10)
SUB	Control de nivel del preamplificador del subwoofer entre 0 y +10 (Z2/SUB debe estar configurado en SUB)

AJUSTES DEL MENÚ DE FAVORITOS	
 FAVORITES	<ul style="list-style-type: none"> Presionar brevemente para acceder a los ajustes/frecuencias memorizadas Mantener presionado para guardar una frecuencia como favorita en la memoria (máx. 9 en FM, 9 en AM y 9 en DAB+)
	<ul style="list-style-type: none"> Girar para navegar Presionar para seleccionar
Ajuste	Función
DELETE	Seleccionar entre las frecuencias guardadas en la memoria para eliminar
REPLACE	Reemplazar una de las frecuencias de la memoria cuando todas están ocupadas



ES

AJUSTES DEL MENÚ DE BLUETOOTH	
 BACK/MENU	<ul style="list-style-type: none"> • Presionar brevemente para acceder a los ajustes
	<ul style="list-style-type: none"> • Girar para navegar • Presionar para seleccionar
Ajuste	Función
PAIR NEW DEVICE	Iniciar el modo de emparejamiento (se desconectarán los dispositivos conectados en ese momento)
CONNECT PAIRED DEVICE	Mostrar todos los dispositivos emparejados para poder conectarlos
SET PRIMARY DEVICE	Asignar prioridad a un dispositivo emparejado para su conexión automática
DELETE PAIRED DEVICE	Seleccionar entre los dispositivos emparejados para eliminarlos
DELETE ALL DEVICES	Eliminar de la memoria todos los dispositivos emparejados

AJUSTES DEL MENÚ DE USB	
 BACK/MENU	<ul style="list-style-type: none"> • Presionar brevemente para acceder a los ajustes
	<ul style="list-style-type: none"> • Girar para navegar • Presionar para seleccionar
Ajuste	Función
RANDOM	Reproducir aleatoriamente todas las pistas de todas las carpetas: encendida o apagada
REPEAT	Repetir la pista actual al finalizar: encendida o apagada
PLAY ALL	Reproducir todas las pistas de todas las carpetas: encendida o apagada
FOLDERS	Mostrar las carpetas del USB
TRACKS	Mostrar las pistas que no se encuentran dentro de ninguna carpeta



ESPECIFICACIONES

Eléctricas	
Tensión de funcionamiento	14,4 V _{cc} (10 V-16 V)
Temperatura de funcionamiento	De -4 °F a +95 °F (de -20 °C a +35 °C)
Consumo de corriente/Valor del fusible	15 A (máx.)/40 mA (en espera)/15 A
Salida de activación remota	500 mA
Display	2,09 in (5,31 cm) Pantalla LCD TFT retroiluminada
Sintonizador	
Sintonizador FM	EE. UU.: De 87,9 MHz a 107,9 MHz (en pasos de 0,2 MHz) EUR: De 87,50 MHz a 108,00 MHz (en pasos de 0,05 MHz) AUS: De 87,50 MHz a 108,00 MHz (en pasos de 0,10 MHz) OTROS: De 87,50 MHz a 108,00 MHz (en pasos de 0,05 MHz)
Sintonizador AM	EE. UU.: De 530 kHz a 1710 kHz (en pasos de 10 kHz) EUR: De 531 kHz a 1602 kHz (en pasos de 9 kHz) AUS: De 531 kHz a 1629 kHz (en pasos de 9 kHz) OTROS: De 531 kHz a 1629 kHz (en pasos de 9 kHz)
Favorites	Máximo 9 en FM, 9 en AM y 9 en DAB+
Bluetooth®	
Perfil	5.0
Especificación Core/códec	Versión 2.1 + EDR/SBC
Alcance de la conexión	Hasta 35 ft/11 m
USB	
Interfaz	USB 2.0 de alta velocidad
Formatos de audio compatibles	MP3, WMA, FLAC, WAV
Límites del sistema de archivos	Carpetas: 255 Archivos en una misma carpeta: 3000 Archivos en total: 9999
Salida de carga	1 A
Salidas de audio del preamplificador	
Canales de salida	Dos pares de conectores RCA estéreo (1,5 V RMS)
Configuración de la zona 2	Z2 (atrás) o subwoofer
Salidas de audio amplificadas	
Potencia RMS nominal a 14,4 V	20 W × 4 a 4 Ω
Opciones de control de audio	
Tono y balance	Bajos, agudos, balance, atenuador (zona 1/zona 2 o subwoofer)
Dimensiones	
Unidad (ancho × altura × profundidad)	4,33 in × 2,48 in × 3,15 in (110 mm × 63 mm × 80 mm)
Agujero de montaje (ancho × altura)	2,83 in × 1,81 in (72 mm × 46 mm)





ES





FCC-KONFORMITÄTSERKLÄRUNG

Dieses Gerät entspricht Teil 15 der FCC-Bestimmungen. Für den Betrieb gelten die folgenden zwei Bedingungen:

(1) Das Gerät darf keine schädlichen Störungen verursachen und (2) das Gerät muss den Empfang von Störungen zulassen, einschließlich von Störungen, die einen unerwünschten Betrieb verursachen können.

Diese Anforderungen gewährleisten angemessenen Schutz gegen elektromagnetische Störungen im häuslichen Bereich.

Dieses Gerät erzeugt und verwendet Funkfrequenzenergie und kann diese ausstrahlen und kann, falls es nicht in Übereinstimmung mit den Anweisungen installiert wird, Störungen der Funkkommunikation verursachen. Allerdings besteht keine Garantie dafür, dass eine Störung bei einer bestimmten Installation nicht doch auftritt. Falls dieses Gerät Funkstörungen im Radio- oder Fernsehempfang verursacht, versuchen Sie, diese mithilfe einer oder mehrerer der folgenden Maßnahmen zu beheben:

- Die Empfangsantenne neu ausrichten oder neu positionieren.
- Abstand zwischen dem Gerät und dem Receiver erhöhen.
- Gerät an einen anderen Stromkreis als den des Receivers anschließen.
- Hilfe des Händlers oder eines erfahrenen Radio-/TV Technikers in Anspruch nehmen.

Jegliche Änderungen oder Modifikationen, die nicht ausdrücklich von der für die Einhaltung verantwortlichen Partei genehmigt wurden, können zum Erlöschen der Betriebserlaubnis für das Gerät führen.

SICHERHEITSMASSNAHMEN

- Verwenden Sie dieses Produkt nur in Fahrzeugen mit 12-Volt-Bordnetz und negativer Masse. Dieses Produkt ist für die Verwendung in Luftfahrzeugen nicht zugelassen.
- Achten Sie auf eine sichere Befestigung dieses Produkts, um Beschädigungen oder Verletzungen bei starkem Seegang zu vermeiden.
- Ersetzen Sie die Sicherung des Stromkabels nicht durch eine Sicherung mit einem anderen Wert. Überbrücken Sie niemals die Sicherung.
- Betreiben Sie Ihr Audiosystem mit einer Lautstärke, die den Umgebungsbedingungen und der Hörsicherheit entspricht.

ÜBERLEGUNGEN ZUR INSTALLATION

- Die Installation erfordert geeignetes Werkzeug und Sicherheitsausrüstung. Es wird eine Installation durch eine Fachkraft empfohlen.
- Dieses Produkt ist wasserbeständig. Nicht eintauchen oder Hochdruckwasserspray aussetzen.
- Schalten Sie vor der Installation das Audiosystem aus und trennen Sie das Batteriesystem vom Audiosystem.
- Installieren Sie das Gerät an einem trockenen, gut belüfteten Ort, der werkseitig installierte Systeme nicht beeinträchtigt. Wenn die Montage in einem Trockenbereich nicht möglich ist, kann auch ein Ort gewählt werden, der keinem starken Spritzwasser ausgesetzt ist.
- Kontrollieren Sie vor dem Schneiden oder Bohren, ob sich hinter den Montageflächen mögliche Hindernisse befinden.
- Die gesamte Systemverkabelung muss in ausreichendem Abstand an beweglichen Teilen und scharfen Kanten vorbeigeführt werden. Sichern Sie Kabel mit Kabelbindern oder Kabelklemmen und verwenden Sie ggf. Tüllen und Kabelband, um Schutz vor scharfen Kanten zu bieten.

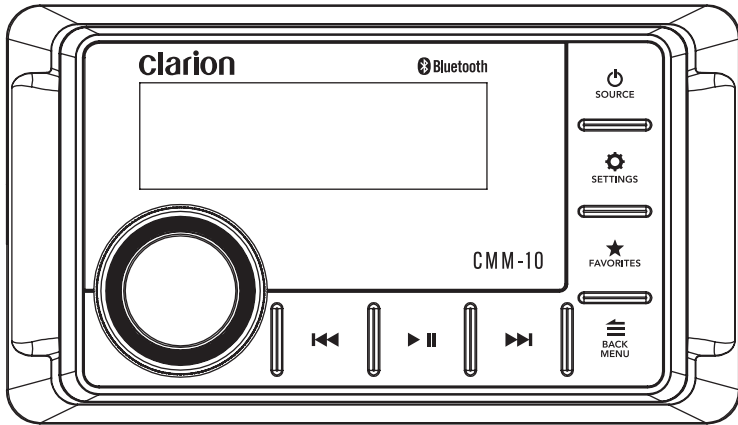

ALLGEMEINE BEDIENFUNKTIONEN





DE

Bedienelement		Funktion
	Volume/ Select	<ul style="list-style-type: none"> • Zum Einstellen der Lautstärke drehen • Zum Navigieren und Auswählen drehen/drücken
	Source/ Power	<ul style="list-style-type: none"> • Kurz drücken zum EINSCHALTEN; lang drücken zum AUSSCHALTEN • Kurz drücken, um die verfügbaren Quellen zu überfliegen
	Settings	<ul style="list-style-type: none"> • Kurz drücken für Zugriff auf Audioeinstellungen (Bass/Höhen/Balance/Fader) • Lang drücken für Zugriff auf Systemeinstellungen (Z2-Sub/Signalton/Region/Dimmer/Diagnose)
	Back/ Menu	<ul style="list-style-type: none"> • Kurz drücken für Schritt zurück oder für das Öffnen quellenspezifischer Menüs
	Favorites	<ul style="list-style-type: none"> • Kurz drücken für Aufruf gespeicherter Voreinstellungen • Lang drücken, um eine Frequenz als Voreinstellung zu speichern (bis zu 9 FM, 9 AM und 9 DAB+)
	Mute/ Pause	<ul style="list-style-type: none"> • Kurz drücken um Stummschaltung de-/aktivieren (AM/FM/DAB+) oder für Pause/Fortsetzen der aktuellen Auswahl (USB/Bluetooth®)
	Forward	<p>Kurz drücken für:</p> <ul style="list-style-type: none"> • Sendersuche manuell vorwärts (AM/FM/DAB+) • Nächsten Titel anwählen (USB/Bluetooth) <p>Lang drücken für:</p> <ul style="list-style-type: none"> • Suchlauf zur nächsten Station (AM/FM/DAB+) • Schnellvorlauf (USB/Bluetooth)
	Backward	<p>Kurz drücken für:</p> <ul style="list-style-type: none"> • Sendersuche manuell rückwärts (AM/FM/DAB+) • Titel neu starten/vorherigen Titel anwählen (USB/Bluetooth) <p>Lang drücken für:</p> <ul style="list-style-type: none"> • Suchlauf zur vorherigen Sender (AM/FM/DAB+) • Schnellrücklauf (USB/Bluetooth)



EINSTELLUNGEN SYSTEMMENÜ	
 SETTINGS	<ul style="list-style-type: none"> • Lang drücken für Zugriff auf Einstellungen
	<ul style="list-style-type: none"> • Zum Navigieren drehen • Für die Anwahl drücken
Einstellung	Funktion
Z2/SUB	Konfiguriert die Vorverstärkerausgänge: Z2 (hinten) oder Subwoofer
BEEP	Akustische Tastendruck-Bestätigung: Ein oder Aus
AREA	Konfiguriert die Tuner-Region: USA, Europa, Australien oder andere
DIMMER	Konfiguriert die Helligkeitseinstellungen für Display und Tasten von 1 bis +10
DIAG	Zeigt die Softwareversion für die Diagnose an



AUDIO-MENÜ-EINSTELLUNGEN	
 SETTINGS	<ul style="list-style-type: none"> • Kurz drücken für Zugriff auf Einstellungen
	<ul style="list-style-type: none"> • Zum Navigieren drehen • Für die Anwahl drücken
Einstellung	Funktion
BASS	Tiefenpegelregelung von -10 bis +10
TREBLE	Höhenpegelregelung von -10 bis +10
BALANCE	Balance-Regler von ganz links (L10) bis ganz rechts (R10)
FADER	Fader-Regelung von ganz vorne (Z1: 10) bis ganz hinten (Z2: 10)
SUB	Subwoofer-Vorverstärker-Pegelregler von 0 bis +10 (Z2/SUB muss auf SUB eingestellt sein)

FAVORITENMENÜ-EINSTELLUNGEN	
 FAVORITES	<ul style="list-style-type: none"> • Kurz drücken, um Einstellungen/gespeicherte Voreinstellungen aufzurufen • Lang drücken, um eine Frequenz als Voreinstellung zu speichern (bis zu 9 FM, 9 AM und 9 DAB+)
	<ul style="list-style-type: none"> • Zum Navigieren drehen • Für die Anwahl drücken
Einstellung	Funktion
DELETE	Einen der gespeicherten Programmplätze entfernen
REPLACE	Einen der gespeicherten Programmplätze neu belegen



DE

BLUETOOTH-MENÜ-EINSTELLUNGEN	
 BACK/MENU	<ul style="list-style-type: none"> • Kurz drücken für Zugriff auf Einstellungen
	<ul style="list-style-type: none"> • Zum Navigieren drehen • Für die Anwahl drücken
Einstellung	Funktion
PAIR NEW DEVICE	Startet den Koppelmodus (aktuell verbundene Geräte werden getrennt)
CONNECT PAIRED DEVICE	Anzeiger aller gekoppelten Geräte
SET PRIMARY DEVICE	Zuweisung einer Priorität für automatische Verbindung für ein gekoppeltes Gerät
DELETE PAIRED DEVICE	Gekoppelte Geräte zum Entfernen anwählen
DELETE ALL DEVICES	Entfernt alle gekoppelten Geräte aus dem Speicher

MENÜEINSTELLUNGEN USB	
 BACK/MENU	<ul style="list-style-type: none"> • Kurz drücken für Zugriff auf Einstellungen
	<ul style="list-style-type: none"> • Zum Navigieren drehen • Für die Anwahl drücken
Einstellung	Funktion
RANDOM	Zufallswiedergabe aller Titel aus allen Ordnern: Ein oder Aus
REPEAT	Wiederholt die Wiedergabe des aktuellen Titels: Ein oder Aus
PLAY ALL	Spielt alle Titel in allen Ordnern ab: Ein oder Aus
FOLDERS	Zeigt Ordner auf dem USB-Stick an
TRACKS	Zeigt Titel an, die sich nicht in einem Ordner befinden



TECHNISCHE DATEN

Elektrisch	
Betriebsspannung	14,4 V DC (10 V - 16 V)
Betriebstemperatur	-4° F bis +95° F (-20° C bis +35° C)
Stromaufnahme/Sicherungswert	15 A (max.) / 40 mA (Standby) / 15 A
Ausgang Ferneinschaltung	500 mA
Display	2,09 Zoll TFT LCD-Hintergrundbeleuchtung
Radio	
FM-Tuner	USA: 87,9 MHz bis 107,9 MHz (0,2-MHz-Schritt) EUR: 87,50 MHz bis 108,00 MHz (0,05 MHz-Schritt) AUS: 87,50 MHz bis 108,00 MHz (0,10 MHz-Schritt) ANDERE: 87,50 MHz bis 108,00 MHz (0,05 MHz-Schritt)
AM-Tuner	USA: 530 kHz bis 1710 kHz (10 kHz-Schritt) EUR: 531 kHz bis 1602 kHz (9-kHz-Schritt) AUS: 531 kHz bis 1629 kHz (9-kHz-Schritt) ANDERE: 531 kHz bis 1629 kHz (9-kHz-Schritt)
Favoriten	Bis zu 9 FM, 9 AM und 9 DAB+
Bluetooth®	
Profil	5.0
Kernspezifikation / Codec	Version 2.1 + EDR / SBC
Reichweite	Bis zu 11 m
USB	
Schnittstelle	USB 2.0 High Speed
Unterstützte Audioformate	MP3, WMA, FLAC, WAV
Dateibeschränkungen	Ordner: 255 Dateien in einem einzigen Ordner: 3.000 Gesamtzahl der Dateien: 9.999
Ladeausgang	1 A
Vorverstärker Audio-Ausgänge	
Ausgangskanäle	Zwei Stereopaare mit Cinch-Steckern (1,5 V RMS)
Zone 2 Konfiguration	Z2 (Hinten) oder Subwoofer
Verstärkte Audioausgänge	
Nennleistung RMS bei 14,4 V	20W x 4 an 4 Ω
Audiosteuerungsoptionen	
Klang & Balance	Bass, Höhen, Balance, Fader (Zone 1 / Zone 2 oder Subwoofer)
Abmessungen	
Einheit B x H x T	4,33 x 2,48 x 3,15 Zoll (110 mm x 63 mm x 80 mm)
Montageloch B x H	2,83 Zoll x 1.81 Zoll (72 mm x 46 mm)





DE





DICHIARAZIONE DI CONFORMITÀ FCC

Il presente dispositivo è conforme con la Parte 15 delle disposizioni FCC. Il funzionamento è soggetto alle seguenti due condizioni: (1) questo dispositivo non deve causare interferenze nocive e (2) questo dispositivo non deve accettare la ricezione di interferenze, comprese quelle che potrebbero causare un funzionamento indesiderato. Questi limiti sono stati studiati per fornire una protezione ragionevole contro le interferenze nocive in un'installazione di tipo residenziale.

Quest'apparecchiatura genera, utilizza e può irradiare energia a radiofrequenza e, se non installata in osservanza delle istruzioni, potrebbe provocare interferenze dannose alle comunicazioni radio. Tuttavia, non vi è alcuna garanzia che le interferenze non si verifichino in una particolare installazione. Se la presente apparecchiatura dovesse causare interferenze nocive alla ricezione di radio o televisione, s'incoraggia l'utente a cercare di correggere le interferenze intraprendendo uno o più provvedimenti indicati di seguito:

- Orientare nuovamente oppure cambiare posizione dell'antenna ricevente.
- Aumentare lo spazio divisorio tra l'apparecchiatura e il ricevitore.
- Collegare l'apparecchiatura a una presa su un circuito diverso da quello a cui è collegato il ricevitore.
- Rivolgersi al rivenditore oppure a un tecnico esperto in materia di radio/TV per richiedere assistenza.

Eventuali variazioni o modifiche non esplicitamente approvate da parti terze responsabili della conformità potrebbero annullare l'autorità dell'utente a utilizzare quest'apparecchiatura.

CONSIDERAZIONI SULLA SICUREZZA

- Utilizzare questo prodotto soltanto in veicoli con impianti elettrici a 12 Volt con sistema di messa a terra negativa. Il presente prodotto non è omologato o approvato per l'utilizzo all'interno di un aeromobile.
- Montare il presente prodotto in posizione salda, al fine di evitare danni o lesioni in condizioni avverse.
- Non sostituire il fusibile cablato di alimentazione con uno di valore differente. Non bypassare mai il fusibile.
- Ascoltare l'impianto audio a livelli appropriati per le condizioni di utilizzo e la protezione dell'udito.

CONSIDERAZIONI SULL'INSTALLAZIONE

- Per l'installazione, si richiedono strumenti e attrezzature di sicurezza idonei. Si consiglia di far eseguire l'installazione da un professionista.
- Questo prodotto è resistente all'acqua. Non immergere o esporre a getti di acqua ad alta pressione.
- Prima dell'installazione, spegnere l'impianto audio e scollegare l'impianto della batteria dall'impianto audio.
- Installare in una sede al riparo dall'umidità, ben ventilata, che non interferisce con i propri impianti installati di fabbrica. Qualora non sia disponibile un ambiente al riparo dall'umidità, è consentito servirsi di una sede che non sia esposta a schizzi eccessivi.
- Prima di eseguire tagli o perforazioni, verificare la presenza di potenziali ostacoli dietro le superfici di montaggio.
- Con cautela, instradare l'intero cablaggio dell'impianto lontano da parti mobili e bordi affilati; assicurare con fascette oppure serracavi e servirsi di occhielli e intelaiature, laddove appropriato, per proteggere dai bordi affilati.

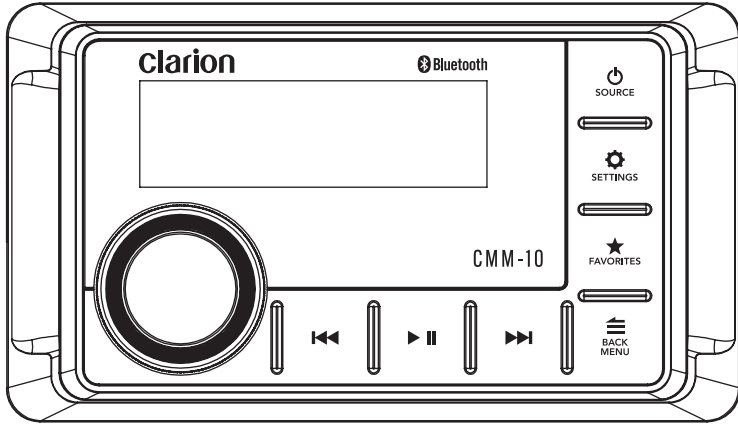

FUNZIONI GENERALI DI COMANDO





Comando		Funzione
	Volume/ Select	<ul style="list-style-type: none"> • Ruotare per regolare il volume • Ruotare/premere per navigare ed effettuare selezioni
	Source/ Power	<ul style="list-style-type: none"> • Premere brevemente per accendere; premere a lungo per spegnere • Premere brevemente per scorrere tra le sorgenti disponibili
	Settings	<ul style="list-style-type: none"> • Premere brevemente per accedere alle impostazioni audio (Bass/Treble/Balance/Fader) • Premere a lungo per accedere alle impostazioni dell'impianto (Z2-Sub/Beep/Area/Dimmer/Diagnostic)
	Back/ Menu	<ul style="list-style-type: none"> • Premere brevemente per eseguire un passaggio indietro oppure accedere ai menu specifici della sorgente
	Favorites	<ul style="list-style-type: none"> • Premere brevemente per accedere alle impostazioni preconfigurate memorizzate • Premere a lungo per memorizzare una frequenza come impostazione preconfigurata (fino a 9 FM, 9 AM e 9 DAB+)
	Mute/ Pause	<ul style="list-style-type: none"> • Premere brevemente per silenziare/riattivare l'audio (AM/FM/DAB+) o interrompere/riprendere la selezione corrente (USB/Bluetooth)
	Forward	<p>Premere brevemente per:</p> <ul style="list-style-type: none"> • Regolare manualmente il sintonizzatore in avanti (AM/FM/DAB+) • Selezionare il brano successivo (USB/Bluetooth) <p>Premere a lungo per:</p> <ul style="list-style-type: none"> • Cercare il canale successivo (AM/FM/DAB+) • Accelerare (USB/Bluetooth)
	Backward	<p>Premere brevemente per:</p> <ul style="list-style-type: none"> • Regolare manualmente il sintonizzatore indietro (AM/FM/DAB+) • Riavviare il brano/selezionare il brano precedente (USB/Bluetooth) <p>Premere a lungo per:</p> <ul style="list-style-type: none"> • Cercare il canale precedente (AM/FM/DAB+) • Riavvolgere rapidamente (USB/Bluetooth)





IMPOSTAZIONI DEL MENU DI SISTEMA

 SETTINGS	<ul style="list-style-type: none">• Premere a lungo per accedere alle impostazioni
	<ul style="list-style-type: none">• Ruotare per navigare• Premere per effettuare selezioni
Impostazione	Funzione
Z2/SUB	Configura le uscite preamplificate: Z2 (posteriore) o Subwoofer
BEEP	Conferma udibile di pressione del tasto: On o Off
AREA	Configura la regione del sintonizzatore: USA, Europa, Australia o altro
DIMMER	Configura la luminosità del display e dei tasti da 0 a +10
DIAG	Visualizza la versione software per la diagnostica

IMPOSTAZIONI DEL MENU AUDIO

 SETTINGS	<ul style="list-style-type: none">• Premere brevemente per accedere alle impostazioni
	<ul style="list-style-type: none">• Ruotare per navigare• Premere per effettuare selezioni
Impostazione	Funzione
BASS	Controllo del livello dei bassi da -10 a +10
TREBLE	Controllo del livello delle alte frequenze da -10 a +10
BALANCE	Controllo del bilanciamento da completamente a sinistra (L10) a completamente a destra (R10)
FADER	Controllo del fader da completamente davanti (Z1: 10) a completamente dietro (Z2: 10)
SUB	Controllo del livello di preamplificazione del subwoofer da 0 a +10 (Z2/SUB deve essere impostato su SUB)

IMPOSTAZIONI DEL MENU DEI PREFERITI

 FAVORITES	<ul style="list-style-type: none">• Premere brevemente per accedere alle impostazioni/preconfigurazioni memorizzate• Premere a lungo per memorizzare una frequenza come impostazione preconfigurata (fino a 9 FM, 9 AM e 9 DAB+)
	<ul style="list-style-type: none">• Ruotare per navigare• Premere per effettuare selezioni
Impostazione	Funzione
DELETE	Seleziona le impostazioni preconfigurate memorizzate da eliminare
REPLACE	Consente la sostituzione quando tutte le sedi preconfigurate sono occupate





IMPOSTAZIONI BLUETOOTH	
 BACK/MENU	<ul style="list-style-type: none">• Premere brevemente per accedere alle impostazioni
	<ul style="list-style-type: none">• Ruotare per navigare• Premere per effettuare selezioni
Impostazione	Funzione
PAIR NEW DEVICE	Avvia la modalità di abbinamento (i dispositivi attualmente collegati saranno disconnessi)
CONNECT PAIRED DEVICE	Visualizza tutti i dispositivi abbinati per il collegamento
SET PRIMARY DEVICE	Attribuisce priorità a un dispositivo abbinato per il collegamento automatico
DELETE PAIRED DEVICE	Seleziona i dispositivi abbinati da rimuovere
DELETE ALL DEVICES	Rimuove tutti i dispositivi abbinati dalla memoria



IMPOSTAZIONI DEL MENU USB	
 BACK/MENU	<ul style="list-style-type: none">• Premere brevemente per accedere alle impostazioni
	<ul style="list-style-type: none">• Ruotare per navigare• Premere per effettuare selezioni
Impostazione	Funzione
RANDOM	Riproduce casualmente tutti i brani in tutte le cartelle: On o Off
REPEAT	Ripete la riproduzione del brano attuale: On o Off
PLAY ALL	Riproduce tutti i brani in tutte le cartelle: On o Off
FOLDERS	Visualizza le cartelle nel dispositivo USB
TRACKS	Visualizza i brani non ubicati in una cartella



SPECIFICHE

Elettriche	
Tensione operativa	14,4 V CC (10 V – 16 V)
Temperatura operativa	Da -4 °F a +95 °F (da -20 °C a +35 °C)
Corrente assorbita / valore del fusibile	15 A (max) / 40 mA (standby) / 15 A
Uscita di accensione in remoto	500 mA
Display	2,09 in. LCD TFT con retroilluminazione
Sintonizzatore	
Sintonizzatore FM	USA: Da 87,9 MHz a 107,9 MHz (incremento di 0,2 MHz) EUR: Da 87,50 MHz a 108,00 MHz (incremento di 0,05 MHz) AUS: Da 87,50 MHz a 108,00 MHz (incremento di 0,10 MHz) ALTRO: Da 87,50 MHz a 108,00 MHz (incremento di 0,05 MHz)
Sintonizzatore AM	USA: Da 530 kHz a 1710 kHz (incremento di 10 kHz) EUR: Da 531 kHz a 1602 kHz (incremento di 9 kHz) AUS: Da 531 kHz a 1629 kHz (incremento di 9 kHz) ALTRO: Da 531 kHz a 1629 kHz (incremento di 9 kHz)
Preferiti	Fino a 9 FM, 9 AM e 9 DAB+
Bluetooth®	
Profilo	5.0
Specifica del core / Codec	Versione 2.1 + EDR / SBC
Intervallo di connessione	Fino a 35 ft / 11 m
USB	
Interfaccia	USB 2.0 High Speed
Formati audio supportati	MP3, WMA, FLAC, WAV
Limiti dei file	Cartelle: 255 File in una cartella: 3.000 File totali: 9.999
Uscita di ricarica	1 A
Uscite audio preamplificate	
Canali di uscita	Due coppie di connettori maschio RCA stereo (1,5 V RMS)
Configurazione della Zona 2	Z2 (posteriore) o Subwoofer
Uscite audio amplificate	
Potenza RMS nominale @ 14,4 V	20 W x 4 @ 4 Ω
Opzioni di controllo dell'audio	
Tono e bilanciamento	Bass, Treble, Balance, Fader (Zona 1 / Zona 2 o Subwoofer)
Dimensioni	
L x A x P dell'unità	4,33 in. x 2,48 in. x 3,15 in. (110 mm x 63 mm x 80 mm)
L x A del foro di montaggio	2,83 in. x 1,81 in. (72 mm x 46 mm)











Clarion®



©2023 Clarion Marine Audio
Printed in China

CMM10/10i-MAN 022423

