

# MEASUREMENT REPORT

## FCC PART 25 Subpart B LTE

---

**FCC ID:** 2AD8UFZMFWH201

**Applicant:** Nokia Solutions and Networks, OY

**Application Type:** Certification

**Product:** Flexi Zone 2400

**Model No.:** FWH2

**Brand Name:** Nokia

**FCC Classification:** Licensed Non-Broadcast Station Transmitter (TNB)

**FCC Rule Part(s):** Part 25 Subpart B (Section 25.149)

**Test Procedure(s):** ANSI C63.26-2015, KDB 971168 D01v03r01

**Test Date:** April 02 ~ 12, 2018

Reviewed By:   
( Paddy Chen )

Approved By:   
(Chenz Ker)



The test results relate only to the samples tested.

This equipment has been shown to be capable of compliance with the applicable technical standards as indicated in the measurement report and was tested in accordance with the measurement procedures specified in ANSI C63.26-2015. Test results reported herein relate only to the item(s) tested.

The test report shall not be reproduced except in full without the written approval of MRT Technology (Taiwan) Co., Ltd.

---

## Revision History

Report No.	Version	Description	Issue Date	Note
1812TW0108-U1	Rev. 01	Initial Report	05-03-2019	Valid

---

## CONTENTS

Description	Page
<b>1. INTRODUCTION .....</b>	<b>6</b>
1.1. Scope .....	6
1.2. MRT Test Location .....	6
<b>2. PRODUCT INFORMATION .....</b>	<b>7</b>
2.1. Feature of Equipment under Test .....	7
2.2. Emission Designator .....	7
2.3. Antenna Information .....	8
2.4. Details of Test Mode .....	8
2.5. Device Capabilities .....	8
2.6. Test Configuration .....	9
2.7. EMI Suppression Device(s)/Modifications.....	9
<b>3. TEST EQUIPMENT CALIBRATION DATE.....</b>	<b>10</b>
<b>4. MEASUREMENT UNCERTAINTY .....</b>	<b>11</b>
<b>5. TEST RESULT .....</b>	<b>12</b>
5.1. Summary.....	12
5.2. 6dB Bandwidth .....	13
5.2.1. Test Limit .....	13
5.2.2. Test Procedure .....	13
5.2.3. Test Setting.....	13
5.2.4. Test Setup .....	13
5.2.5. Test Result.....	14
5.3. Maximum Transmit Power .....	23
5.3.1. Test Limit .....	23
5.3.2. Test Procedure .....	23
5.3.3. Test Setting.....	23
5.3.4. Test Setup .....	23
5.3.5. Test Result.....	24
5.4. Power Spectral Density Measurement.....	25
5.4.1. Test Limit .....	25
5.4.2. Test Procedure Used .....	25
5.4.3. Test Setting.....	25
5.4.4. Test Setup .....	25
5.4.5. Test Setup .....	26
5.5. Frequency Stability Measurement.....	35

---

5.5.1.	Test Limit .....	35
5.5.2.	Test Procedure Used .....	35
5.5.3.	Test Setting.....	35
5.5.4.	Test Setup .....	36
5.5.5.	Test Result.....	37
5.6.	Band Edge Measurement.....	38
5.6.1.	Test Limit .....	38
5.6.2.	Test Procedure Used .....	38
5.6.3.	Test Setting.....	38
5.6.4.	Test Setup .....	39
5.6.5.	Test Result.....	40
5.7.	Conducted Spurious Emissions Measurement .....	41
5.7.1.	Test Limit .....	41
5.7.2.	Test Procedure Used .....	41
5.7.3.	Test Setting.....	41
5.7.4.	Test Setup .....	42
5.7.5.	Test Result.....	43
5.8.	Radiated Spurious Emissions Measurement .....	46
5.8.1.	Test Limit .....	46
5.8.2.	Test Procedure Used .....	46
5.8.3.	Test Setting.....	46
5.8.4.	Test Setup .....	47
5.8.5.	Test Result.....	48
<b>6.</b>	<b>CONCLUSION .....</b>	<b>49</b>

## §2.1033 General Information

<b>Applicant:</b>	Nokia Solutions and Networks, OY
<b>Applicant Address:</b>	2000 W. Lucent Lane, Naperville, Illinois, United States, 60563
<b>Manufacturer:</b>	Nokia Solutions and Networks, OY
<b>Manufacturer Address:</b>	2000 W. Lucent Lane, Naperville, Illinois, United States, 60563
<b>Test Site:</b>	MRT Technology (Taiwan) Co., Ltd
<b>Test Site Address:</b>	No. 38, Fuxing Second Rd., Guishan Dist., Taoyuan City 333, Taiwan (R.O.C)

### Test Facility / Accreditations

Measurements were performed at MRT Laboratory located in Fuxing Rd., Taoyuan, Taiwan ( R.O.C )

- MRT facility is a FCC registered (Reg. No. 153292) test facility with the site description report on file and is designated by the FCC as an Accredited Test Film.
- MRT facility is an IC registered (MRT Reg. No. 21723-1) test laboratory with the site description on file at Industry Canada.
- MRT Lab is accredited to ISO 17025 by the American Association for Laboratory Accreditation (TAF) under the American Association for Laboratory Accreditation Program (TAF Cert. No. 3261) in EMC, Telecommunications and Radio testing for FCC, Industry Taiwan, EU and TELEC Rules.

# 1. INTRODUCTION

## 1.1. Scope

Measurement and determination of electromagnetic emissions (EMC) of radio frequency devices including intentional and/or unintentional radiators for compliance with the technical rules and regulations of the Federal Communications Commission and the Industry Canada Certification and Engineering Bureau.

## 1.2. MRT Test Location

The map below shows the location of the MRT LABORATORY, its proximity to the Taoyuan City. These measurement tests were conducted at the MRT Technology (Taiwan) Co., Ltd. Facility located at No.38, Fuxing 2nd Rd., Guishan Dist., Taoyuan City 33377, Taiwan (R.O.C).

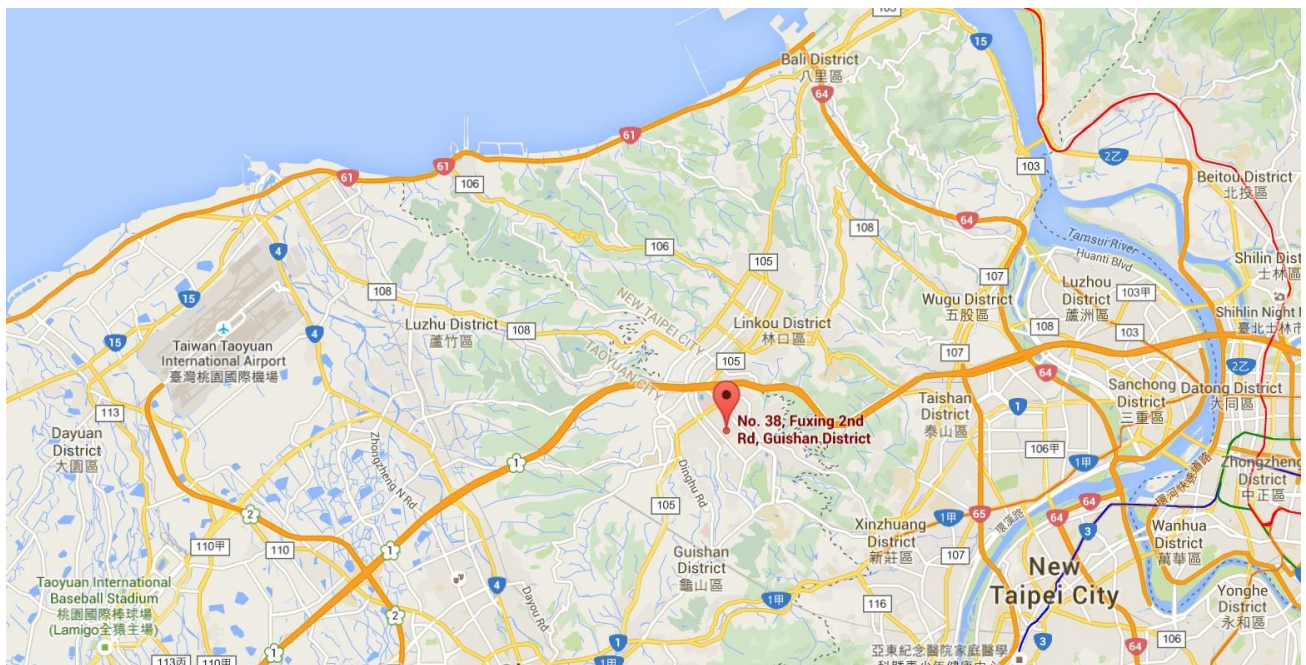

## 2. PRODUCT INFORMATION

### 2.1. Feature of Equipment under Test

Product Name:	Flexi Zone 2400
Model No.:	FWH2
Brand Name:	Nokia
Serial No.:	EB183400030
Hardware Version:	FWH2, 474328A.X11
Software Version:	TLF18A
GPS Frequency Range:	1575.42MHz
FCC ID of Built-in Bluetooth Module:	2AD8UNBTM01
LTE Operating Band:	LTE TDD Band 53
Frequency Range:	Uplink: 2483.5 ~ 2495 MHz; Downlink: 2483.5 ~ 2495 MHz
Carriers:	Up to 1 carrier
Carrier Bandwidth:	10MHz
Type of Modulation:	QPSK, 16QAM, 64QAM, 256QAM
T <sub>x</sub> & R <sub>x</sub> Configuration:	2T <sub>x</sub> & 2R <sub>x</sub>
Maximum Output Power:	Conducted Power: 29.87dBm EIRP: 34.88dBm
Emission Designator:	Refer to section 2.2
Antenna Information:	Refer to section 2.3 Transmit Antenna is connected directly to the 6dB attenuator
Accessory Information:	
Attenuator:	Position: One attenuator connected directly to the FWH2 main and diversity antenna ports. Attenuation: 6dB Nokia Part Number: 091860A

### 2.2. Emission Designator

Channel Bandwidth 10MHz:	QPSK: 8M95G7D
	16QAM: 8M95W7D
	64QAM: 8M96W7D
	256QAM: 8M95W7D

### 2.3. Antenna Information

Technology	Antenna Type	Nokia Part Number	Antenna Gain
LTE Band 53	Omni Antenna	473227A	2dBi

### 2.4. Details of Test Mode

Test Item	Test Frequency (MHz)	Channel Bandwidth (MHz)	Modulation
6dB Bandwidth	2488.5, 2489, 2490	10	QPSK, 16QAM, 64QAM, 256QAM
Output Power	2488.5, 2489, 2490	10	QPSK, 16QAM, 64QAM, 256QAM
Power Spectral Density	2488.5, 2489, 2490	10	QPSK, 16QAM, 64QAM, 256QAM
Frequency Stability	2489	10	16QAM
Band Edge	2488.5, 2489, 2490	10	16QAM
Conducted Emission	2488.5, 2489, 2490	10	16QAM
Radiated Spurious Emission	2488.5, 2489, 2490	10	16QAM

Note: Test Items “Band Edge Measurements” & “Conducted Spurious Emissions” & “Radiated Spurious Emissions” have been assessed all the test modes, and showed the worst test data in this report.

### 2.5. Device Capabilities

This device contains the following capabilities:

LTE TDD Band 53.

Note: The maximum achievable duty cycles for all modes were determined based on measurements performed on a spectrum analyzer in zero-span mode with RBW = 1MHz, VBW = 3MHz, and detector = average. The duty cycles are as follows:

Modulation	Duty Cycle
QPSK	67.5 %
16QAM	67.5 %
64QAM	68.0 %
256QAM	68.0 %



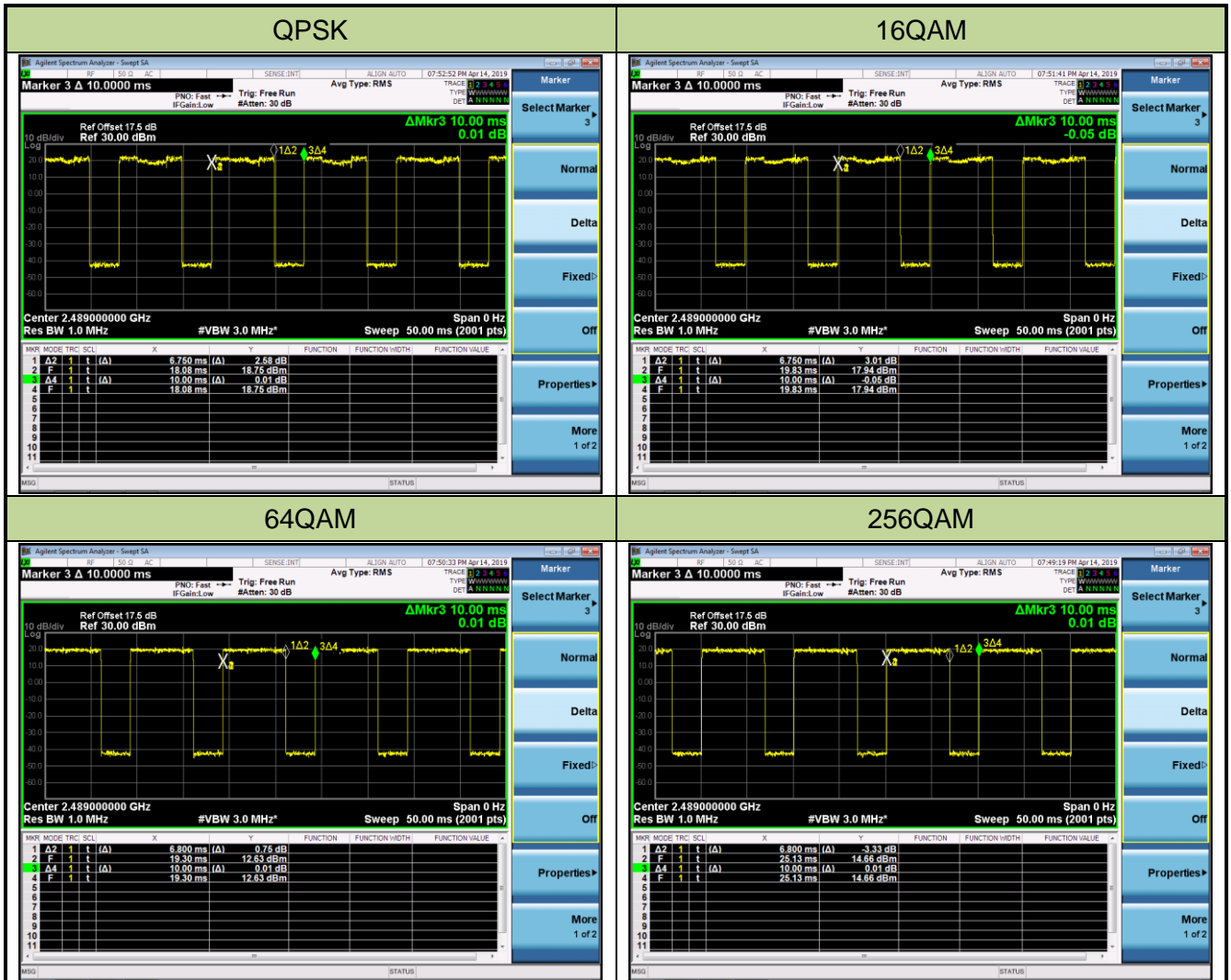

## 2.6. Test Configuration

The device was tested per the guidance of KDB 971168 D01v03r01. ANSI C63.26-2015 was used to reference the appropriate EUT setup for radiated spurious emissions testing.

## 2.7. EMI Suppression Device(s)/Modifications

No EMI suppression device(s) were added and/or no modifications were made during testing.

### 3. TEST EQUIPMENT CALIBRATION DATE

#### Radiated Emissions - AC1

Instrument	Manufacturer	Type No.	Asset No.	Cali. Interval	Cali. Due Date
Active Loop Antenna	SCHWARZBECK	FMZB 1519B	MRTTWA00002	1 year	2019/04/24
Broadband TRILOG Antenna	SCHWARZBECK	VULB 9162	MRTTWA00001	1 year	2019/05/22
Log-Periodic Antenna	SCHWARZBECK	VULP 9118A	MRTSUE06174	3 years	2019/08/01
Broadband Hornantenna	SCHWARZBECK	BBHA 9120D	MRTSUE06023	1 year	2019/10/19
Broadband Hornantenna	SCHWARZBECK	BBHA 9120D	MRTTWA00003	1 year	2019/04/24
Breitband Hornantenna	SCHWARZBECK	BBHA 9170	MRTTWA00004	1 year	2019/04/23
Broadband Preamplifier	SCHWARZBECK	BBV 9718	MRTTWA00005	1 year	2019/04/23
Broadband Amplifier	SCHWARZBECK	BBV 9721	MRTTWA00006	1 year	2019/04/23
Signal Analyzer	R&S	FSV40	MRTTWA00007	1 year	2020/03/20
EMI Test Receiver	R&S	ESR3	MRTTWA00009	1 year	2020/03/19
EXA Signal Analyzer	KEYSIGHT	N9010A	MRTTWA00012	1 year	2019/07/30
Antenna Cable	HUBERSUHNER	SF106	MRTTWE00010	1 year	2019/05/18
Temperature/Humidity Meter	TFA	35.1078.10.IT	MRTTWA00032	1 year	2019/05/21

#### Conducted Test Equipment - TR3

Instrument	Manufacturer	Type No.	Asset No.	Cali. Interval	Cali. Due Date
X-Series USB Peak and Average Power Sensor	KEYSIGHT	U2021XA	MRTTWA00014	1 year	2019/04/24
X-Series USB Peak and Average Power Sensor	KEYSIGHT	U2021XA	MRTTWA00015	1 year	2020/03/20
EXA Signal Analyzer	KEYSIGHT	N9010A	MRTTWA00012	1 year	2019/07/30
Signal Analyzer	R&S	FSV40	MRTTWA00007	1 year	2020/03/20
Programmable AC Power Source	N4L	N4A3	MRTTWA00068	1 year	2020/02/12
Temperature/Humidity Meter	TFA	35.1078.10.IT	MRTTWA00033	1 year	2019/05/21

Software	Version	Function
EMI Software	V3	EMI Test Software

#### 4. MEASUREMENT UNCERTAINTY

Where relevant, the following test uncertainty levels have been estimated for tests performed on the EUT as specified in CISPR 16-4-2. This uncertainty represents an expanded uncertainty expressed at approximately the 95% confidence level using a coverage factor of  $k = 2$ .

<b>Conducted Measurement</b>
Measuring Uncertainty for a Level of Confidence of 95% ( $U=2Uc(y)$ ): 2.65dB
<b>Radiated Emission Measurement</b>
Measuring Uncertainty for a Level of Confidence of 95% ( $U=2Uc(y)$ ): 4.25dB (30M~1G) 4.40dB (1G~18G)

## 5. TEST RESULT

### 5.1. Summary

FCC Section(s)	Test Description	Test Limit	Test Condition	Test Result	Reference
25.149 (c)(4)(ii)	6dB bandwidth	$\geq 500\text{kHz}$	Conducted	Pass	Section 5.2
25.149 (c)(4)(iii)	Maximum Transmit Power	Conducted $\leq 30\text{dBm}$ ; EIRP $\leq 6\text{dBw}$	Conducted / Radiated	Pass	Section 5.3
25.149 (c)(4) (iv)	Maximum Power Spectral Density	$\leq 8\text{dBm}/3\text{kHz}$	Conducted	Pass	Section 5.4
2.1055	Frequency Stability	N/A		Pass	Section 5.5
2.1051; 25.149 (c)(4) (v) (vi)	Band Edge Measurements	Refer to Section 5.6		Pass	Section 5.6
2.1051; 25.149 (c)(4) (v) (vi)	Conducted Spurious Emissions	Refer to Section 5.7		Pass	Section 5.7
2.1053; 25.149 (c)(4) (v) (vi)	Radiated Spurious Emissions	Refer to Section 5.8	Radiated	Pass	Section 5.8

#### Notes:

1. The analyzer plots shown in this section were all taken with a correction table loaded into the analyzer. The correction table was used to account for the losses of the cables and attenuators used as part of the system to connect the EUT to the analyzer at all frequencies of interest.
2. Test Items “Band Edge Measurements” & “Conducted Spurious Emissions” & “Radiated Spurious Emissions” have been assessed all the test modes, and showed the worst test data in this report.

## 5.2. 6dB Bandwidth

### 5.2.1. Test Limit

The minimum 6dB bandwidth shall be at least 500 kHz.

### 5.2.2. Test Procedure

KDB 971168 D01v03r01 - Section 4.2

ANSI C63.26-2015 - Section 5.4.3

### 5.2.3. Test Setting

1. Set center frequency to the nominal EUT channel center frequency;
2. RBW = 100 kHz (The nominal RBW shall be in the range of 1% to 5% of the anticipated OBW);
3.  $VBW \geq 3 \times RBW$ ;
4. Detector = Peak;
5. Trace mode = max hold;
6. Sweep = auto couple;
7. Allow the trace to stabilize;
8. The dynamic range of the spectrum analyzer at the selected RBW shall be more than 10 dB below the target “-X dB” requirement, i.e., if the requirement calls for measuring the -6 dB OBW, the spectrum analyzer noise floor at the selected RBW shall be at least 36 dB below the reference level

### 5.2.4. Test Setup

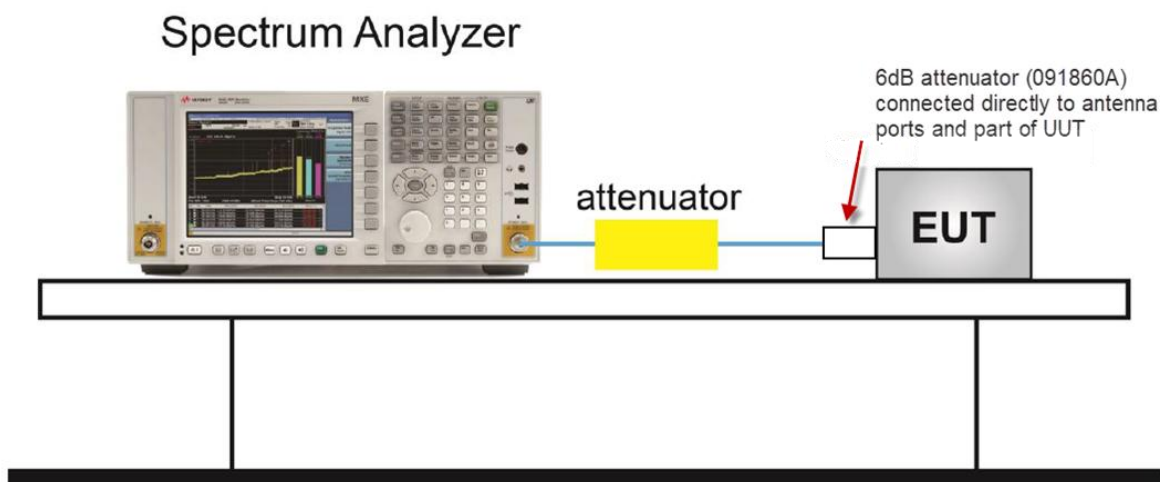

**5.2.5. Test Result**

Product	Flexi Zone 2400	Temperature	25°C
Test Engineer	Kevin Ker	Relative Humidity	54%
Test Site	SR2	Test Date	2019/04/14

Test Mode	Modulation	Frequency (MHz)	99% Bandwidth(MHz)	6dB Bandwidth(MHz)	Limit (MHz)	Result
Chain D						
Band 53	QPSK	2488.5	8.95	9.02	≥ 0.5	Pass
		2489.0	8.94	9.01	≥ 0.5	Pass
		2490.0	8.94	9.02	≥ 0.5	Pass
Band 53	16QAM	2488.5	8.94	9.00	≥ 0.5	Pass
		2489.0	8.94	8.99	≥ 0.5	Pass
		2490.0	8.95	9.00	≥ 0.5	Pass
Band 53	64QAM	2488.5	8.95	9.04	≥ 0.5	Pass
		2489.0	8.95	9.03	≥ 0.5	Pass
		2490.0	8.95	9.02	≥ 0.5	Pass
Band 53	256QAM	2488.5	8.94	9.01	≥ 0.5	Pass
		2489.0	8.94	9.01	≥ 0.5	Pass
		2490.0	8.95	9.02	≥ 0.5	Pass
Chain M						
Band 53	QPSK	2488.5	8.94	9.01	≥ 0.5	Pass
		2489.0	8.95	9.02	≥ 0.5	Pass
		2490.0	8.95	9.01	≥ 0.5	Pass
Band 53	16QAM	2488.5	8.95	9.03	≥ 0.5	Pass
		2489.0	8.95	9.02	≥ 0.5	Pass
		2490.0	8.95	9.01	≥ 0.5	Pass
Band 53	64QAM	2488.5	8.95	9.04	≥ 0.5	Pass
		2489.0	8.96	9.05	≥ 0.5	Pass
		2490.0	8.94	9.02	≥ 0.5	Pass
Band 53	256QAM	2488.5	8.94	9.02	≥ 0.5	Pass
		2489.0	8.94	9.01	≥ 0.5	Pass
		2490.0	8.94	9.01	≥ 0.5	Pass

### Occupied Bandwidth - Chain D (QPSK)

2488.5MHz

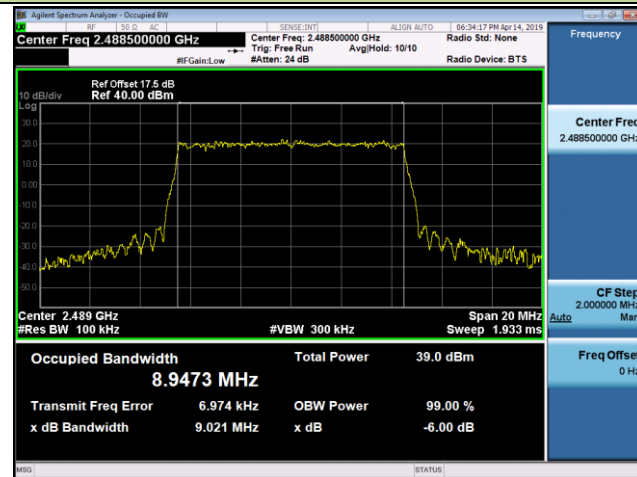

2489.0MHz

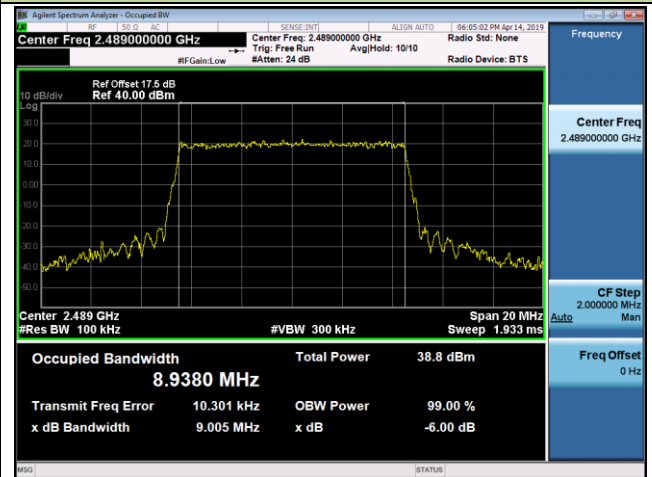

2490.0MHz

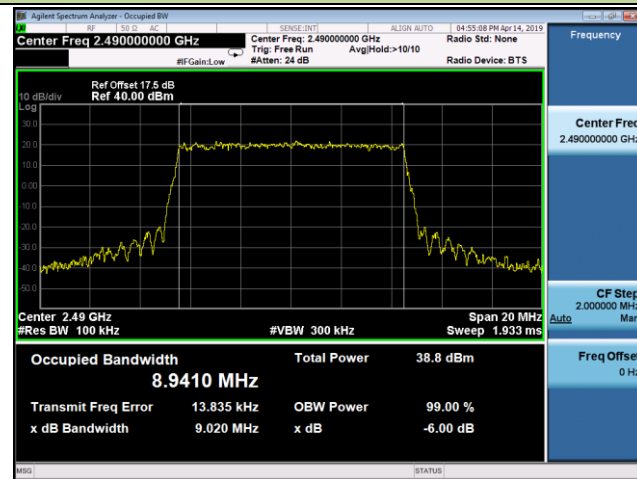

Occupied Bandwidth - Chain D (16QAM)

2488.5MHz

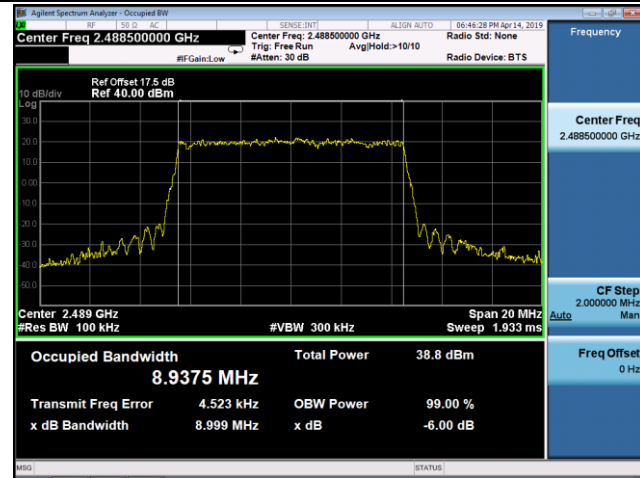

2489.0MHz

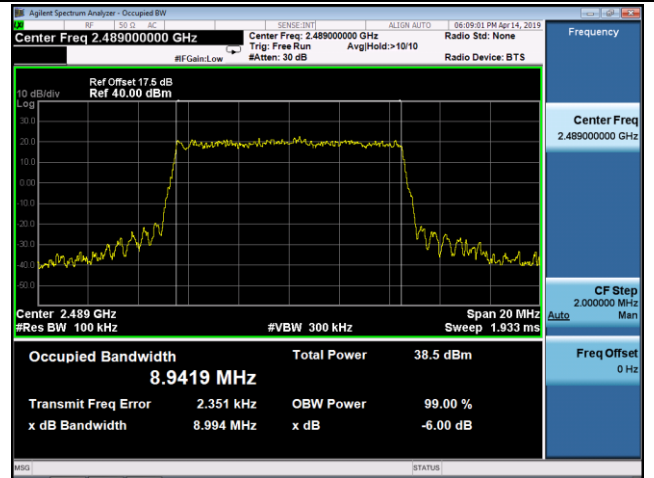

2490.0MHz

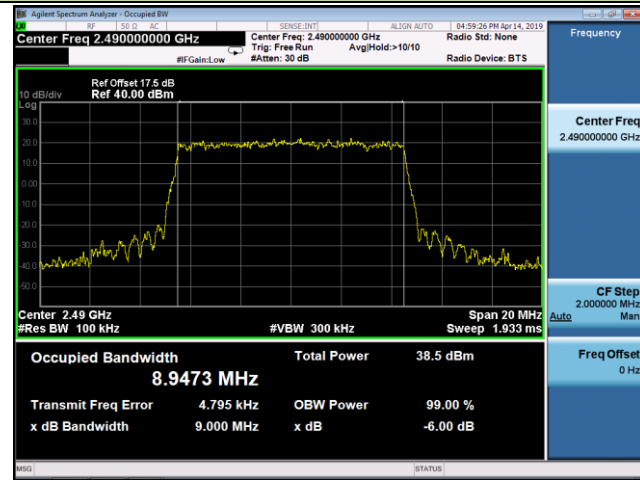



## Occupied Bandwidth - Chain D (64QAM)

2488.5MHz

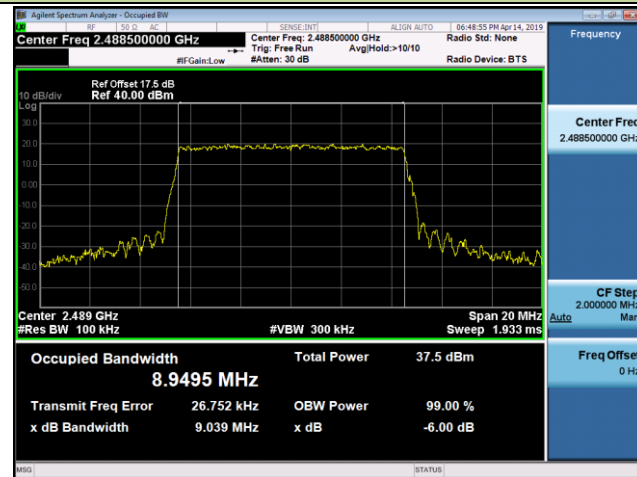

2489.0MHz

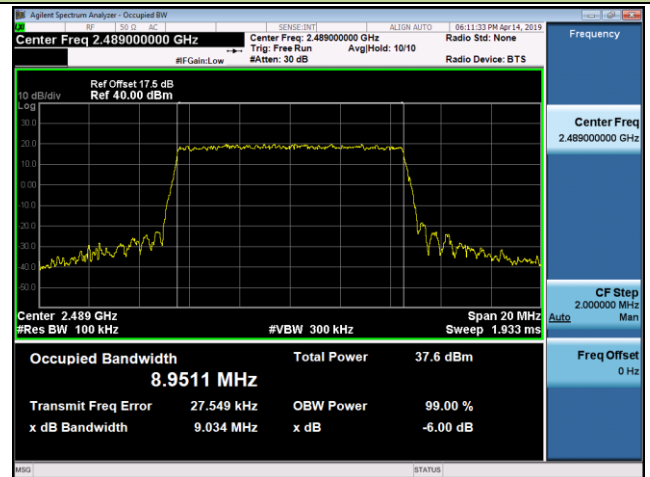

2490.0MHz

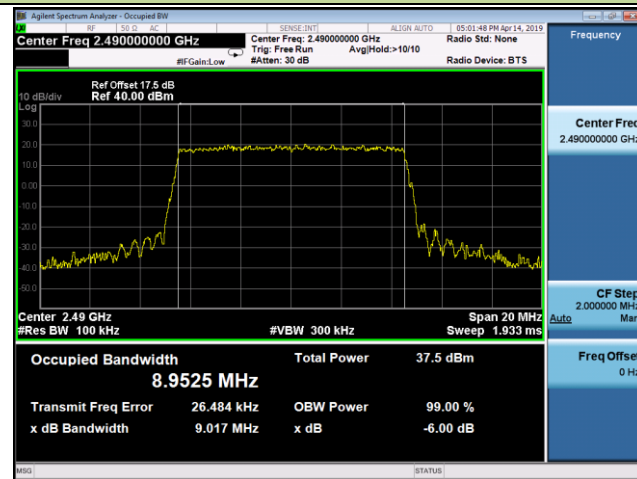

Occupied Bandwidth - Chain D (256QAM)

2488.5MHz

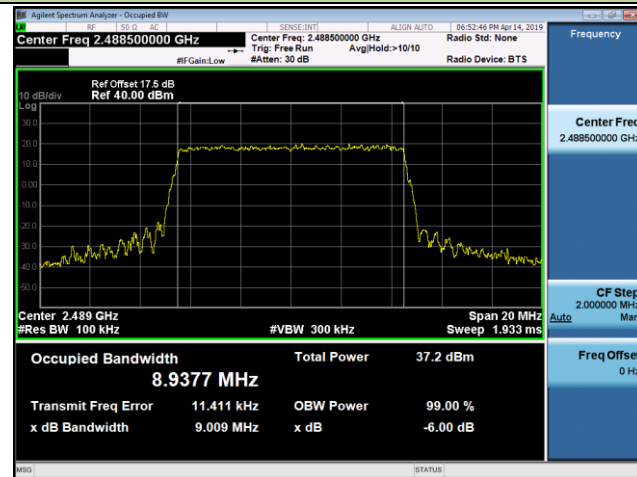

2489.0MHz

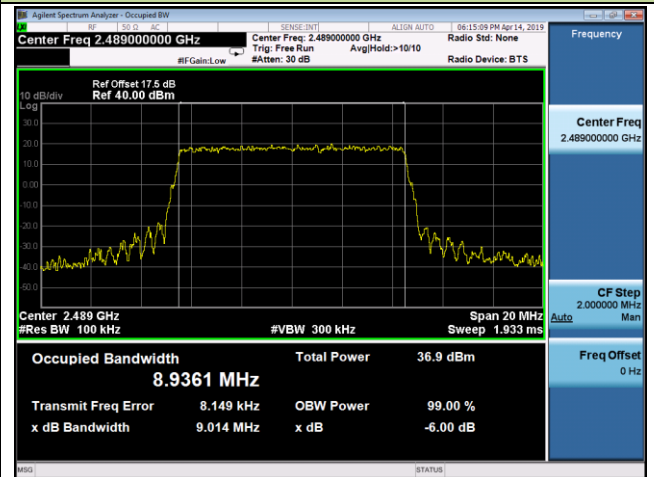

2490.0MHz

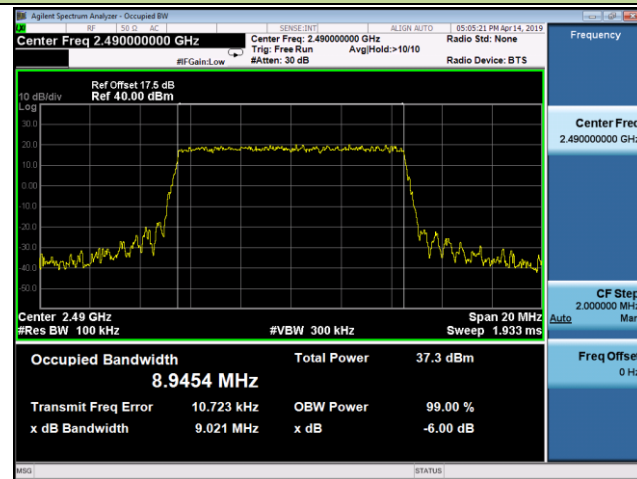

Occupied Bandwidth - Chain M (QPSK)

2488.5MHz

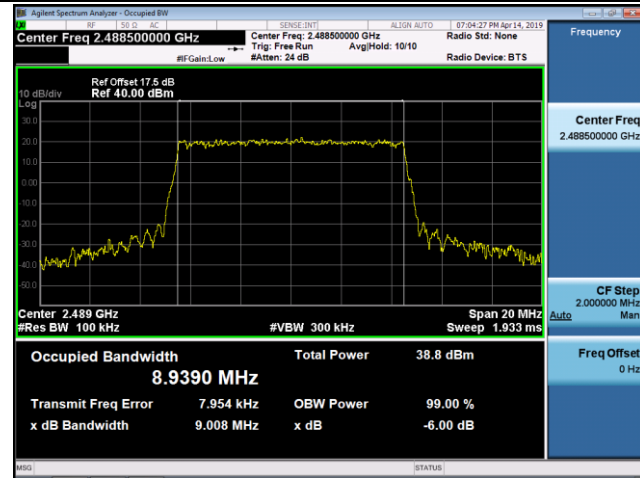

2489.0MHz

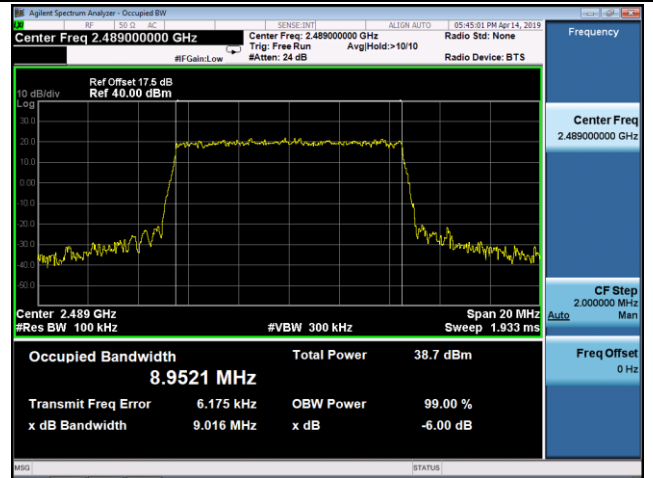

2490.0MHz

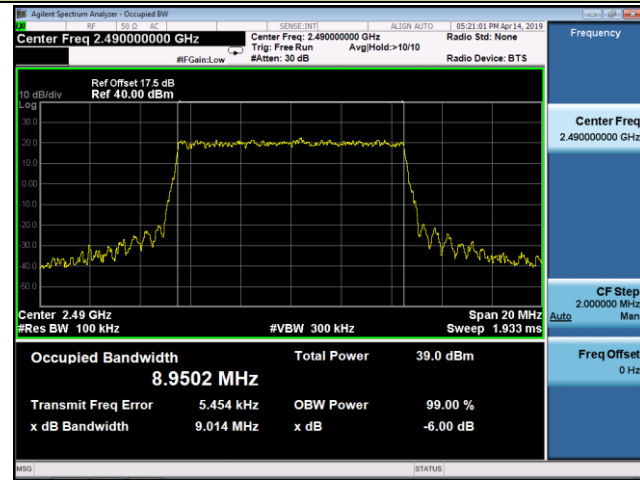

Occupied Bandwidth - Chain M (16QAM)

2488.5MHz

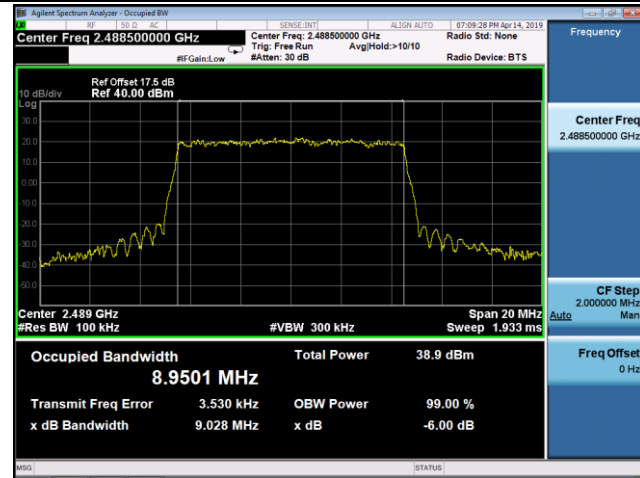

2489.0MHz

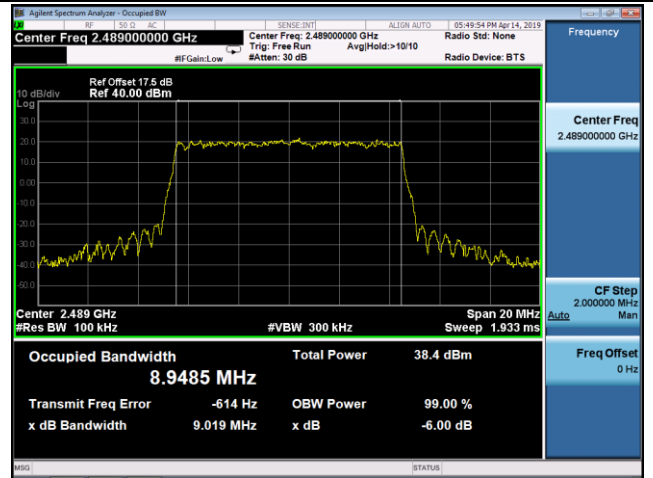

2490.0MHz

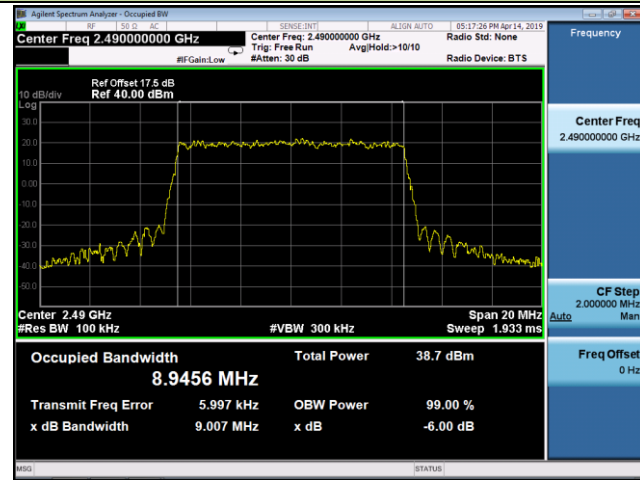

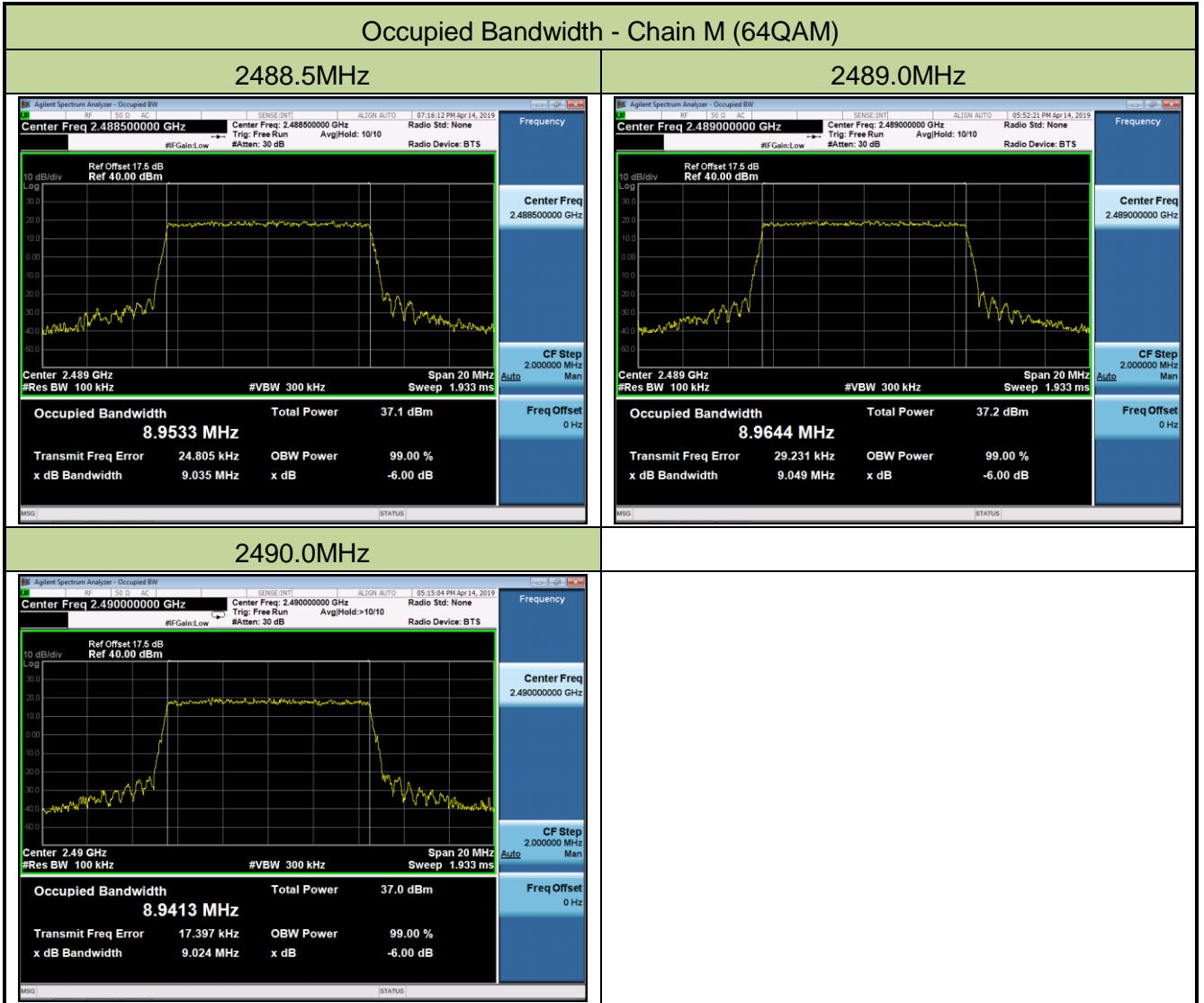

Occupied Bandwidth - Chain M (256QAM)

2488.5MHz

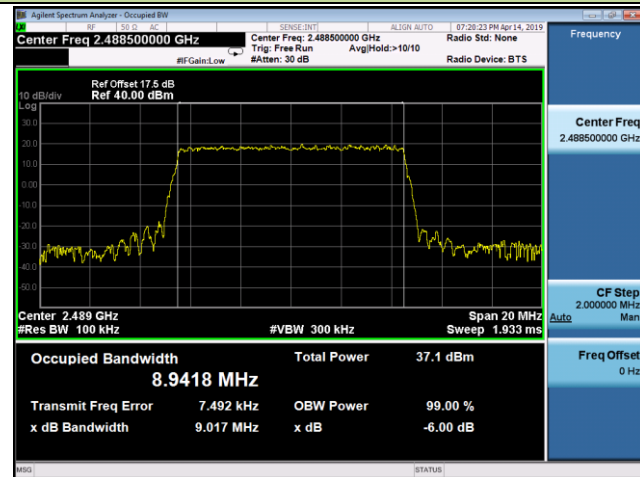

2489.0MHz

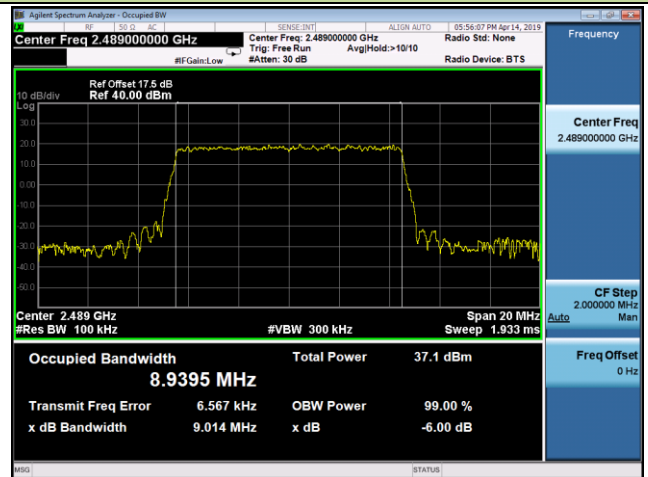

2490.0MHz

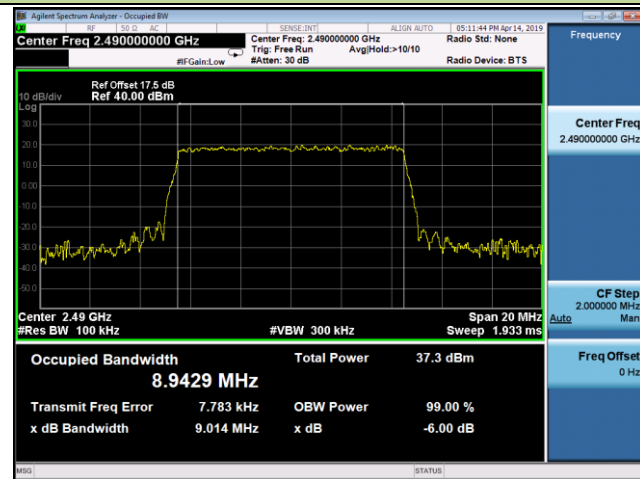

### 5.3. Maximum Transmit Power

#### 5.3.1. Test Limit

The maximum transmit power is no more than 1 W with a peak EIRP of no more than 6 dBw.

EIRP Limit = 6 + 30 = 36 dBm

#### 5.3.2. Test Procedure

KDB 971168 D01v03r01 - Section 5.2.4

ANSI C63.26-2015 - Section 5.2.4.2

#### 5.3.3. Test Setting

##### **Method AVGPM-G (Measurement using a gated RF average-reading power meter)**

Measurements may be performed using a wideband gated RF power meter provided that the gate parameters are adjusted such that the power is measured only when the EUT is transmitting at its maximum power control level. Since this measurement is made only during the ON time of the transmitter, no duty cycle correction is required.

#### 5.3.4. Test Setup

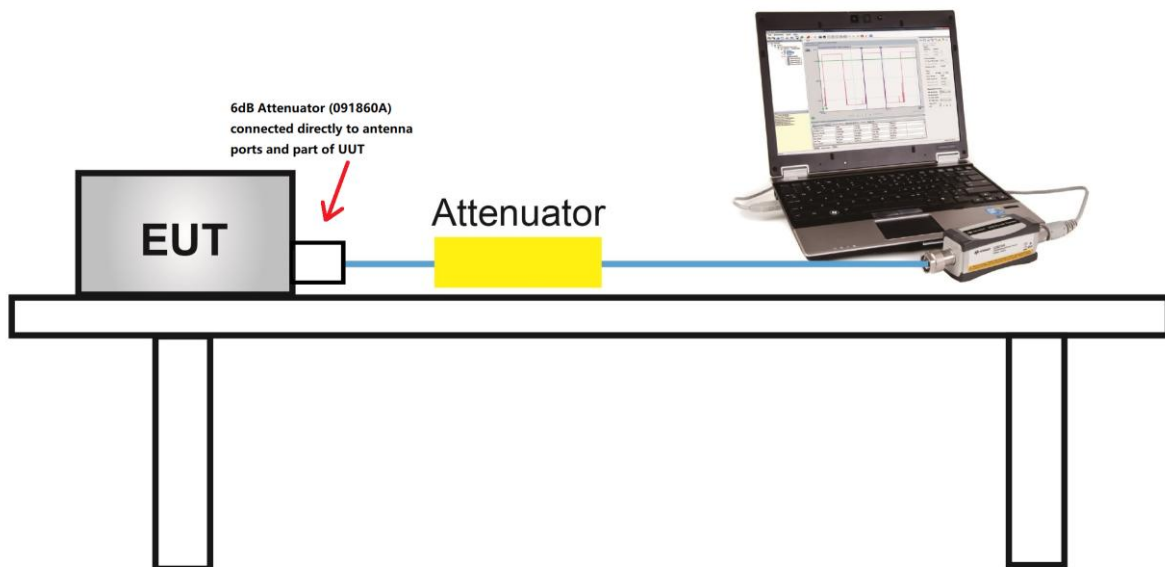

### 5.3.5. Test Result

Product	Flexi Zone 2400	Temperature	25°C
Test Engineer	Kevin Ker	Relative Humidity	54%
Test Site	SR2	Test Date	2019/04/14

Test Mode	Modulation	Frequency (MHz)	Output Power (dBm)		Total Power (dBm)	Output Power Limit (dBm)	EIRP (dBm)	EIRP Limit (dBm)	Result
			Chain D	Chain M					
Band 53	QPSK	2488.5	26.75	26.56	29.67	≤ 30.00	34.68	≤ 36.00	Pass
		2489.0	26.83	26.77	29.81	≤ 30.00	34.82	≤ 36.00	Pass
		2490.0	26.93	26.59	29.77	≤ 30.00	34.78	≤ 36.00	Pass
Band 53	16QAM	2488.5	27.00	26.66	29.84	≤ 30.00	34.85	≤ 36.00	Pass
		2489.0	26.66	26.74	29.71	≤ 30.00	34.72	≤ 36.00	Pass
		2490.0	26.98	26.73	29.87	≤ 30.00	34.88	≤ 36.00	Pass
Band 53	64QAM	2488.5	26.84	26.45	29.66	≤ 30.00	34.67	≤ 36.00	Pass
		2489.0	26.69	26.68	29.70	≤ 30.00	34.71	≤ 36.00	Pass
		2490.0	26.92	26.74	29.84	≤ 30.00	34.85	≤ 36.00	Pass
Band 53	256QAM	2488.5	26.67	26.40	29.55	≤ 30.00	34.56	≤ 36.00	Pass
		2489.0	26.79	26.51	29.66	≤ 30.00	34.67	≤ 36.00	Pass
		2490.0	26.87	26.54	29.72	≤ 30.00	34.73	≤ 36.00	Pass

Note 1: The Total Average Power (dBm) =  $10 \cdot \log\{10^{(\text{Chain D Average Power} / 10)} + 10^{(\text{Chain M Average Power} / 10)}\}$ .

Note 2: EIRP (dBm) = Total Average Power (dBm) + Antenna Gain (dBi) + Array Gain ( $10 \cdot \log(\frac{N_{\text{ANT}}}{N_{\text{SS}}})$ ).



## 5.4. Power Spectral Density Measurement

### 5.4.1. Test Limit

The maximum power spectral density conducted to the antenna is not greater than 8 dBm in any 3 kHz band during any time interval of continuous transmission

### 5.4.2. Test Procedure Used

KDB 971168 D01v03r01 - Section 5.4

ANSI C63.26-2015 - Section 5.2.4.5

### 5.4.3. Test Setting

1. Set the analyzer center frequency to the OBW center frequency
2. RBW = 3kHz
3. VBW = 10kHz
4. Sweep time = auto
5. Detector = power averaging (rms)
6. Set sweep trigger to "free run."
7. Trace average at least 100 traces in power averaging (rms) mode if sweep is set to auto-couple.  
To accurately determine the average power over the on and off time of the transmitter, it can be necessary to increase the number of traces to be averaged above 100, or if using a manually configured sweep time, increase the sweep time.
8. Add 10 log (1/duty cycle) to the measured power level to compute the average power during continuous transmission.

### 5.4.4. Test Setup

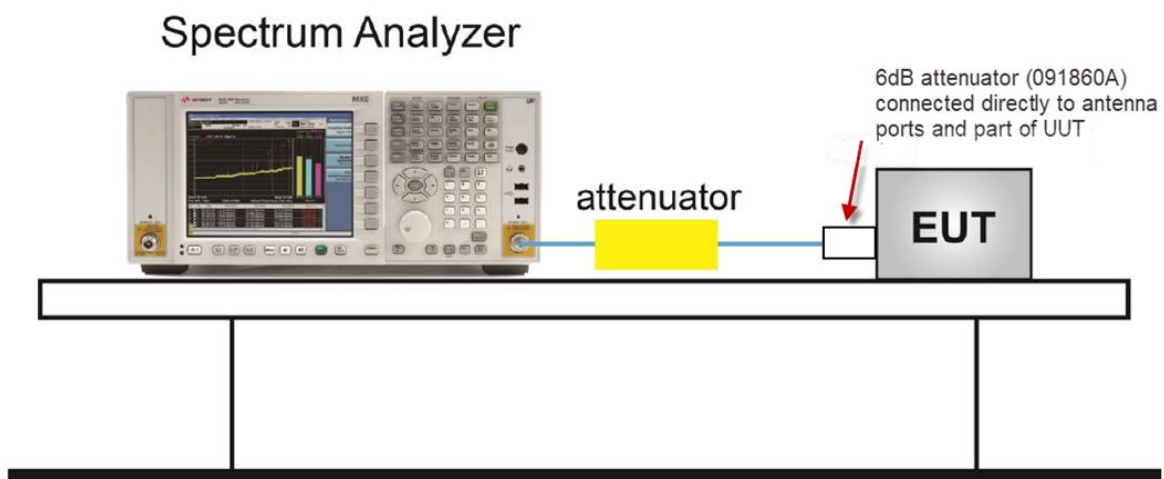

**5.4.5. Test Setup**

Product	Flexi Zone 2400	Temperature	25°C
Test Engineer	Kevin Ker	Relative Humidity	54%
Test Site	SR2	Test Date	2019/04/14

Test Mode	Modulation	Frequency (MHz)	PSD (dBm/3kHz)		Duty Cycle	Factor	Total PSD (dBm/3kHz)	Limit (dBm/3kHz)	Result
			Chain D	Chain M					
Band 53	QPSK	2488.5	-4.48	-4.52	67.5%	1.71	0.22	≤ 8.00	Pass
		2489.0	-3.91	-4.22			0.66	≤ 8.00	Pass
		2490.0	-4.41	-4.66			0.19	≤ 8.00	Pass
Band 53	16QAM	2488.5	-4.48	-4.64	67.5%	1.71	0.16	≤ 8.00	Pass
		2489.0	-4.81	-4.27			0.19	≤ 8.00	Pass
		2490.0	-4.63	-4.59			0.11	≤ 8.00	Pass
Band 53	64QAM	2488.5	-5.60	-5.90	68.0%	1.67	-1.07	≤ 8.00	Pass
		2489.0	-5.35	-5.49			-0.74	≤ 8.00	Pass
		2490.0	-4.98	-5.41			-0.51	≤ 8.00	Pass
Band 53	256QAM	2488.5	-6.18	-5.94	68.0%	1.67	-1.38	≤ 8.00	Pass
		2489.0	-5.67	-5.75			-1.03	≤ 8.00	Pass
		2490.0	-6.04	-5.58			-1.12	≤ 8.00	Pass

Note: The Total PSD (dBm/3kHz) =  $10 \cdot \log\{10^{(\text{Chain D PSD}/10)} + 10^{(\text{Chain M PSD}/10)}\} + 10 \cdot \log(1/\text{duty cycle})$

Power Spectral Density - Chain D (QPSK)

2488.5MHz

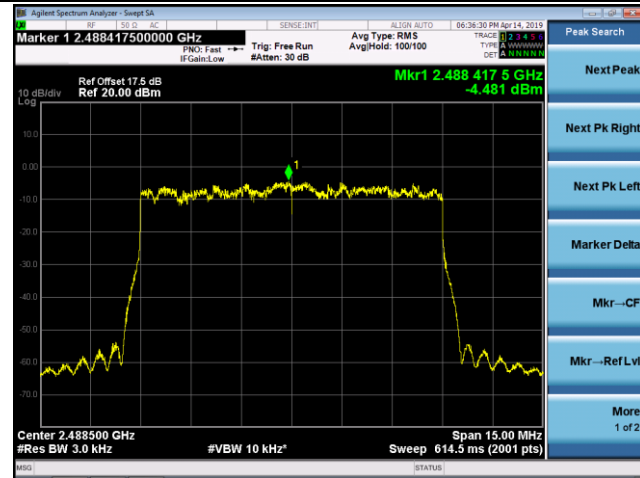

2489.0MHz

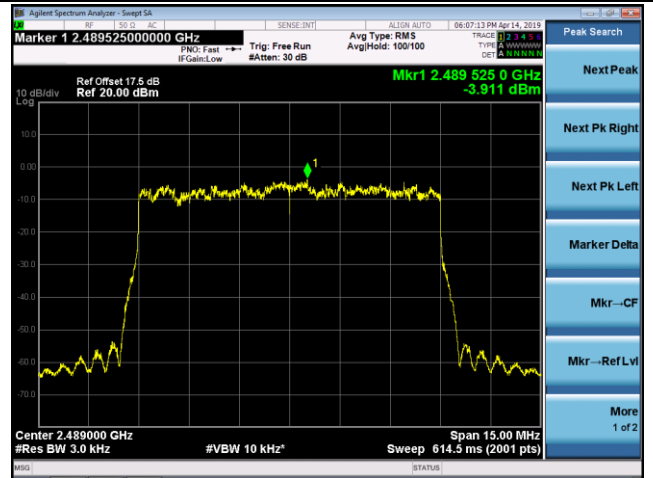

2490.0MHz

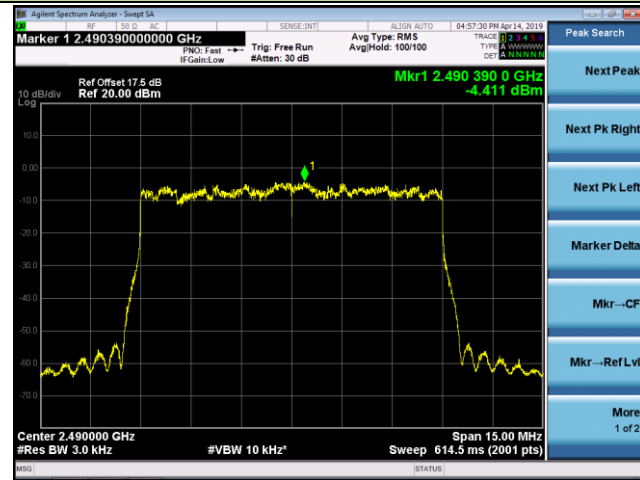

Power Spectral Density - Chain D (16QAM)

2488.5MHz

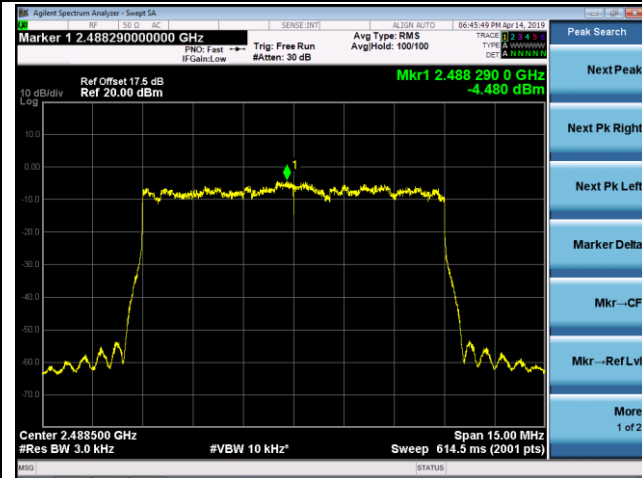

2489.0MHz

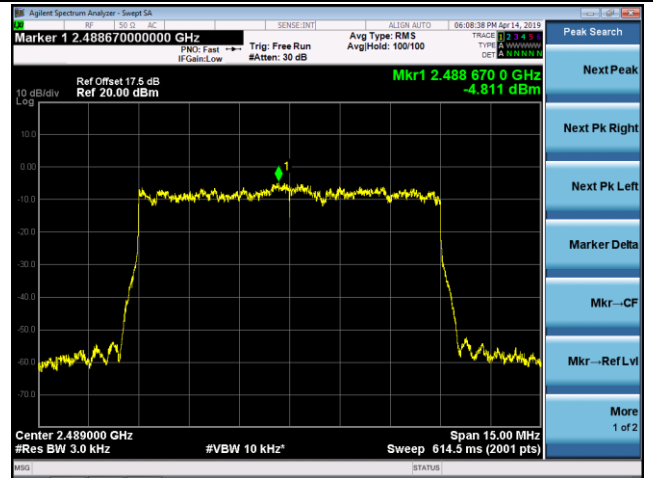

2490.0MHz

