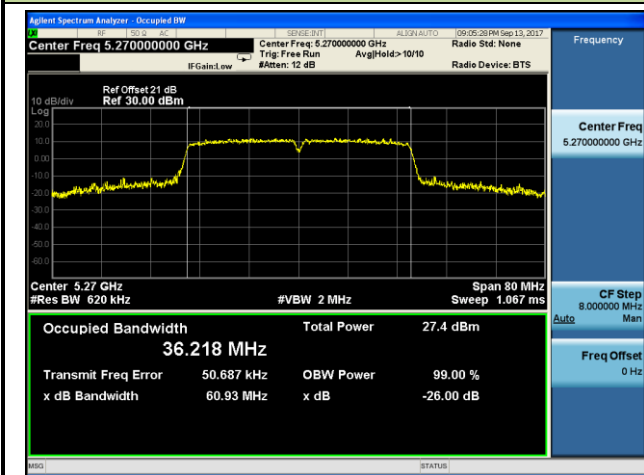
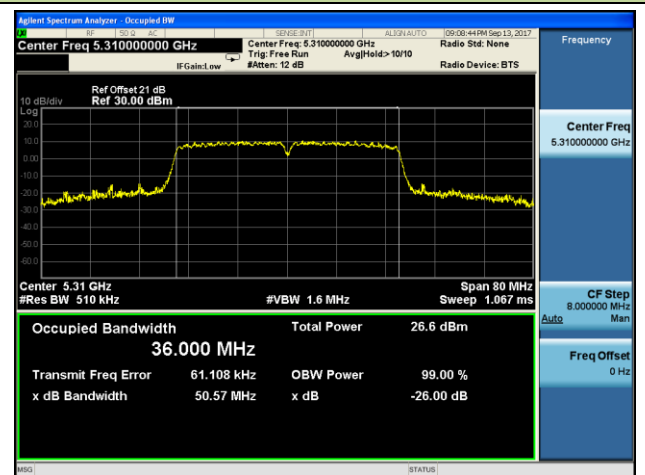
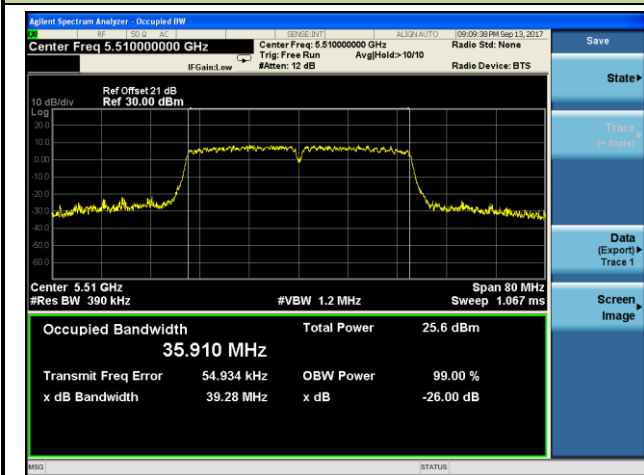
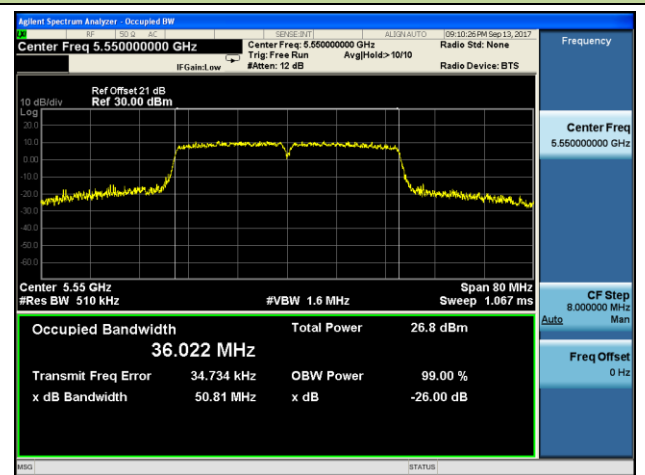
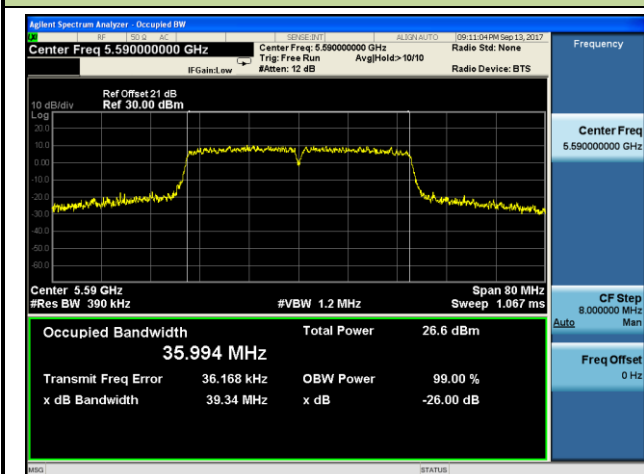
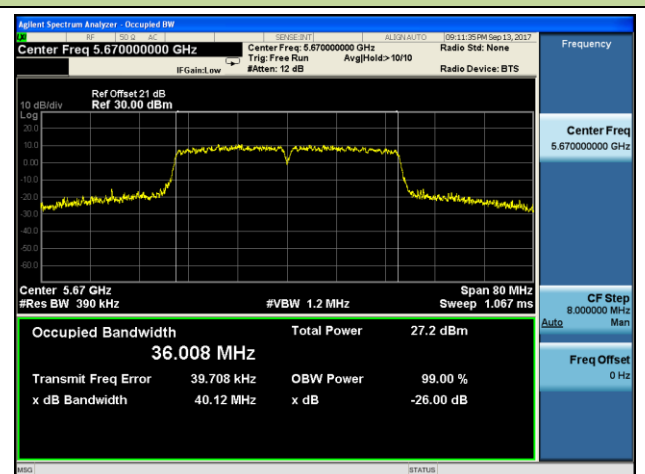
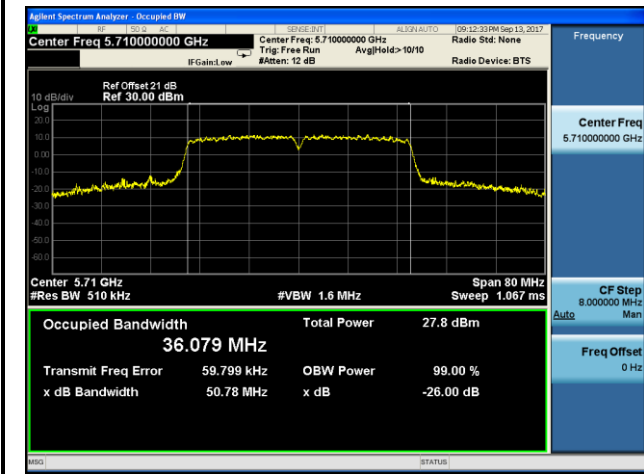
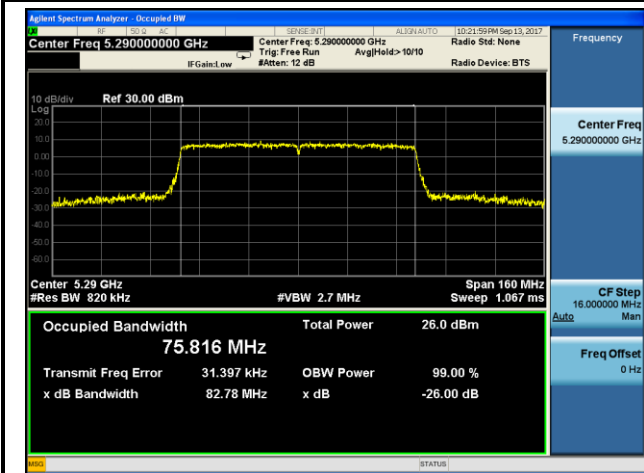
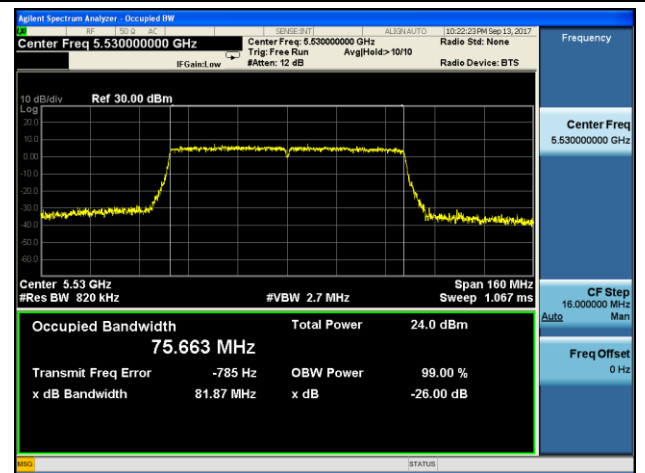
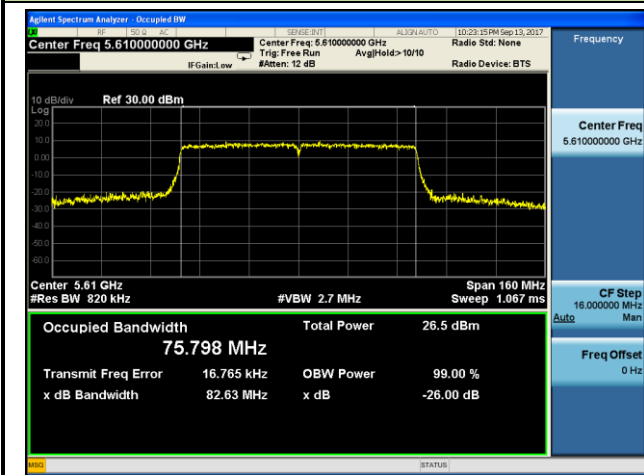
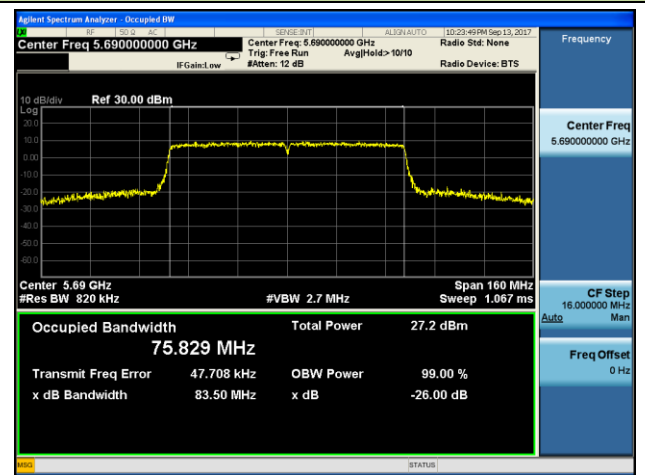
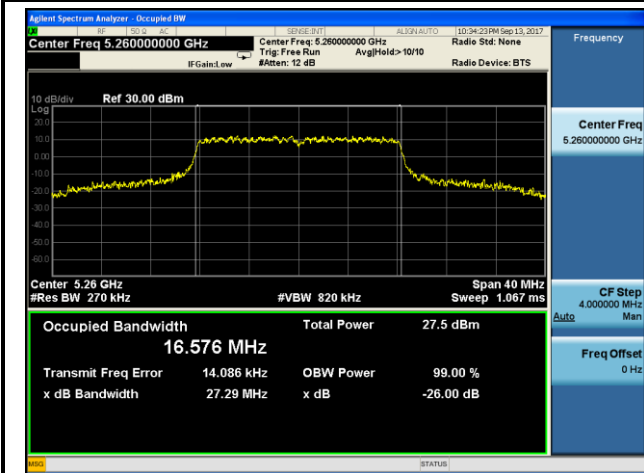
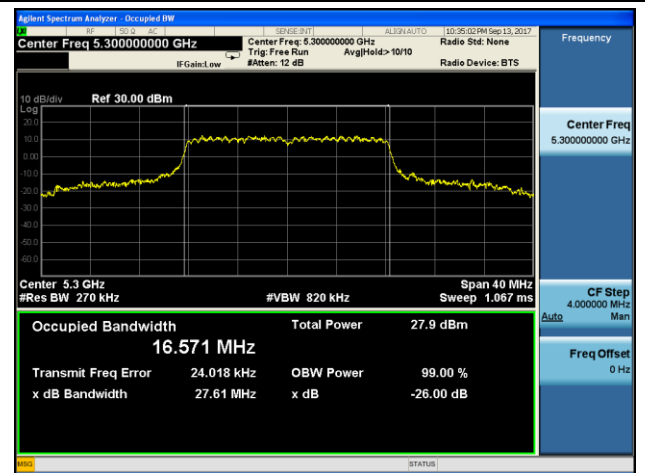
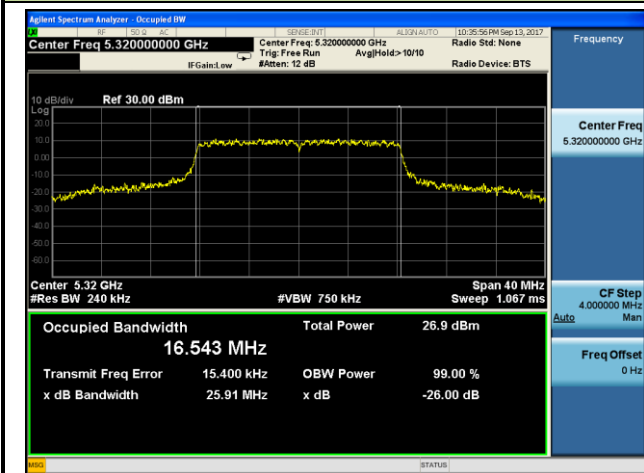
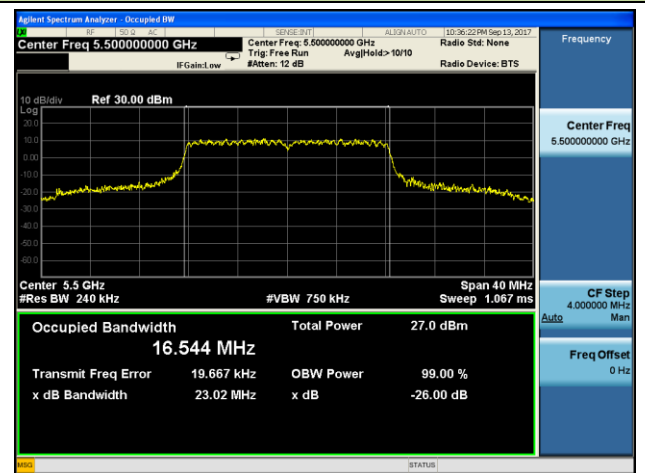
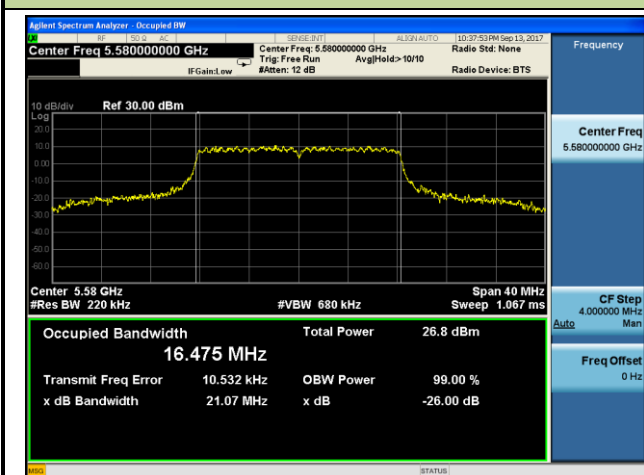
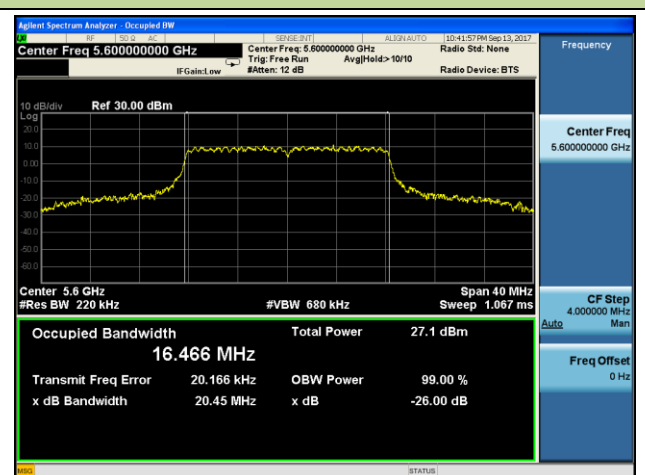

802.11ac-VHT40 26dB Bandwidth & 99% Bandwidth - Ant 2
Channel 54 (5270MHz)

Channel 62 (5310MHz)

Channel 102 (5510MHz)

Channel 110 (5550MHz)

Channel 118 (5590MHz)

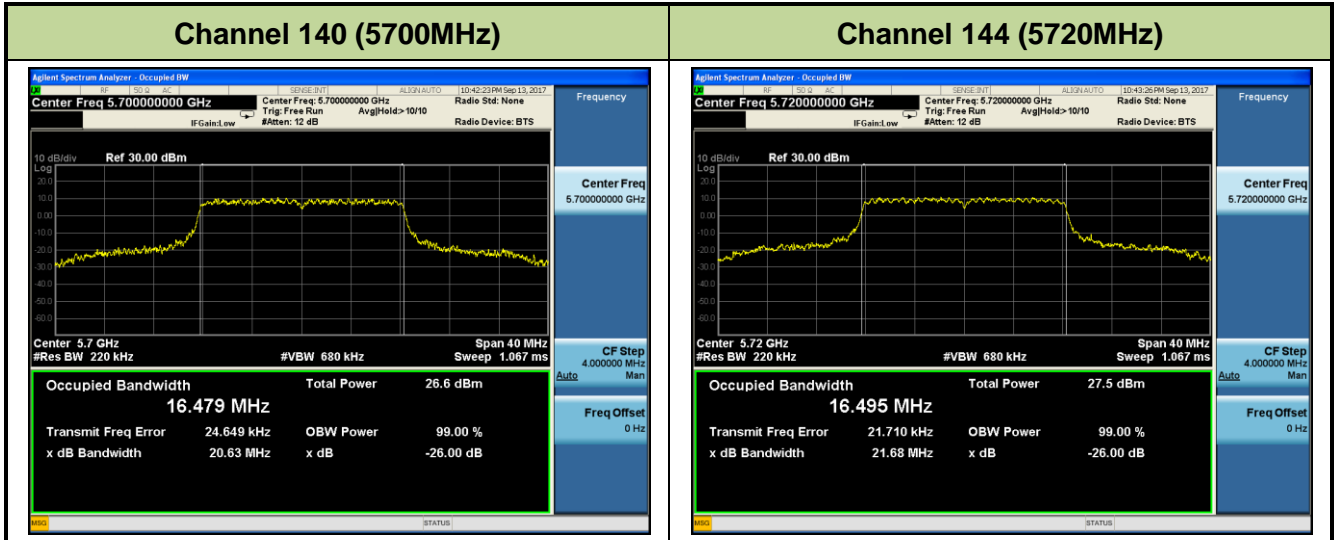
Channel 134 (5670MHz)

Channel 142 (5710MHz)



802.11ac-VHT80 26dB Bandwidth & 99% Bandwidth - Ant 2
Channel 58 (5290MHz)

Channel 106 (5530MHz)

Channel 122 (5610MHz)

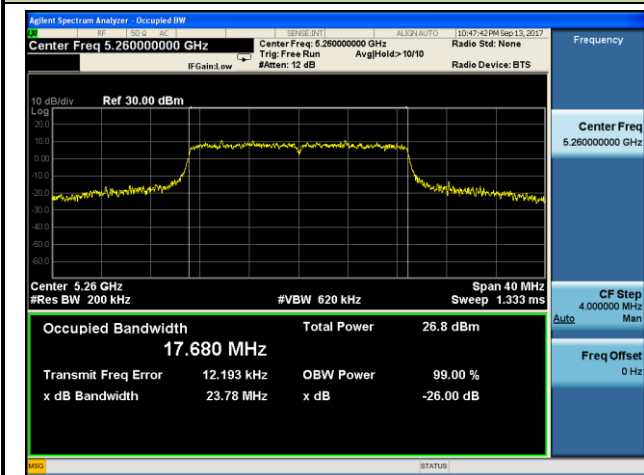
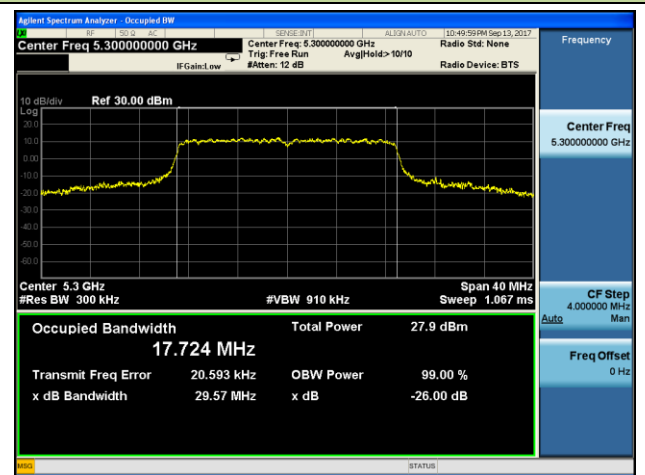
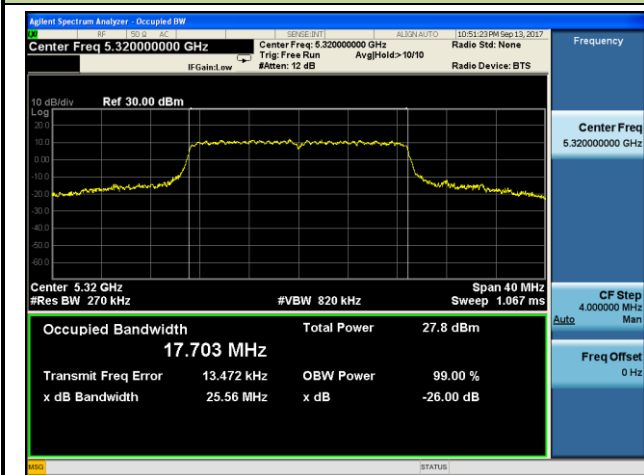
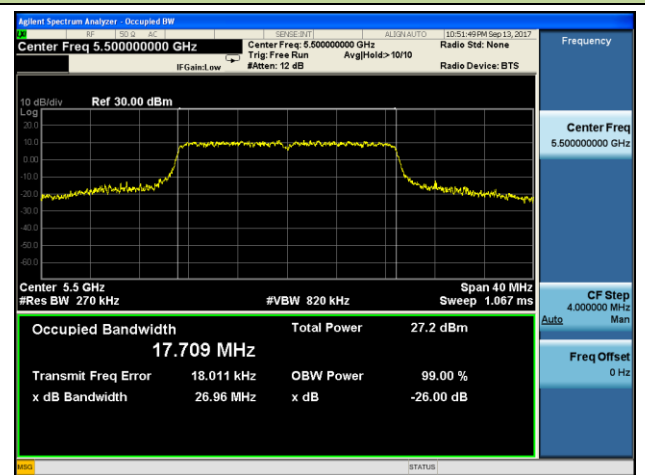
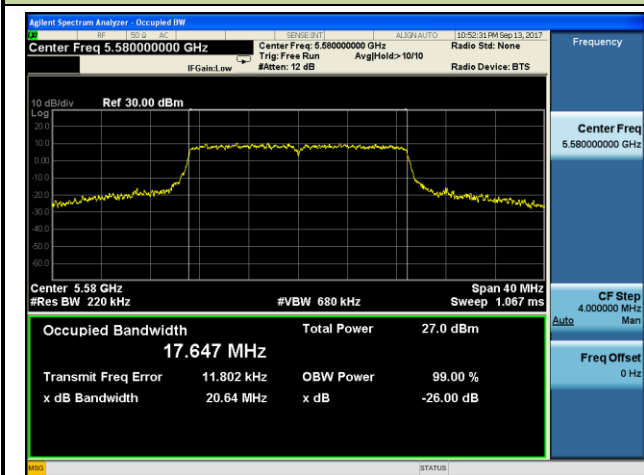
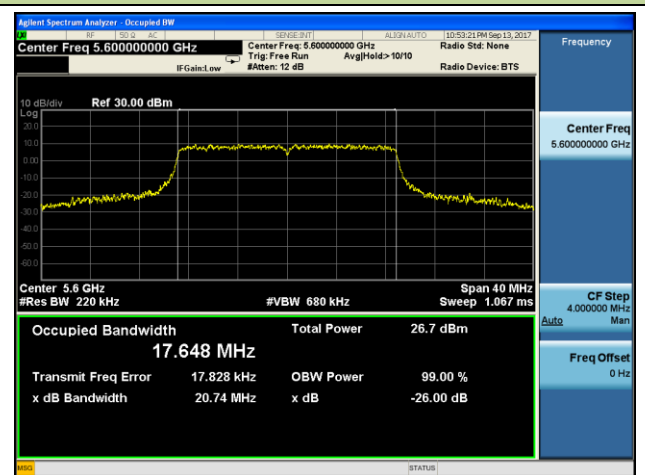
Channel 138 (5690MHz)

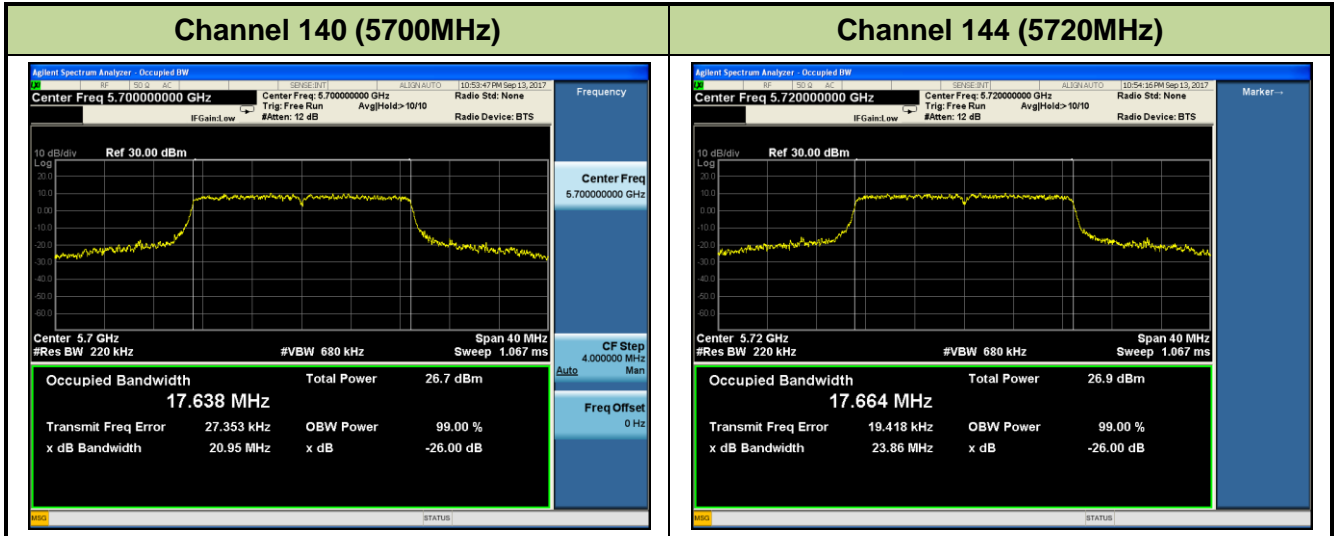
802.11a 26dB Bandwidth & 99% Bandwidth - Ant 2 / Ant 1 + 2
Channel 52 (5260MHz)

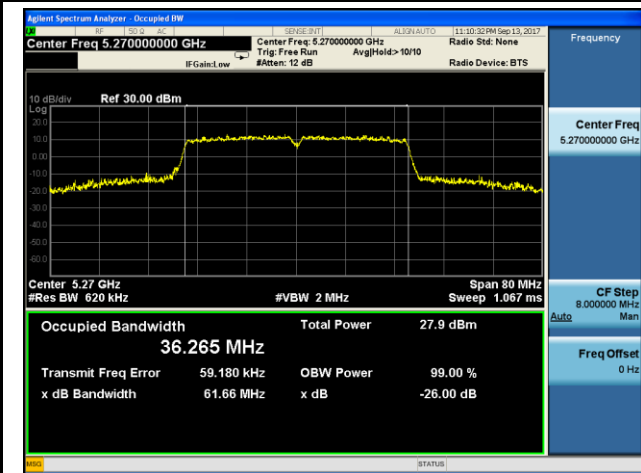
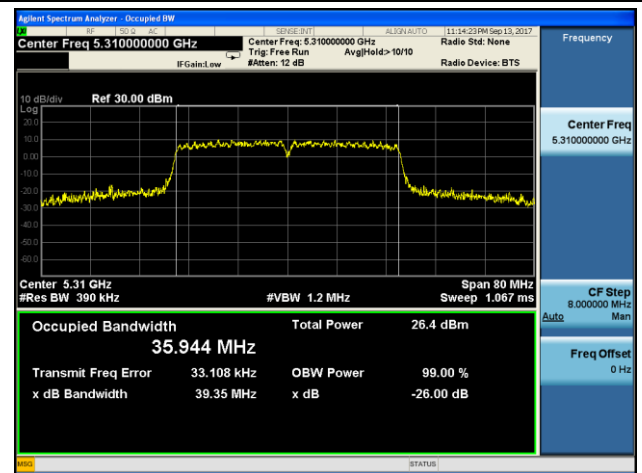
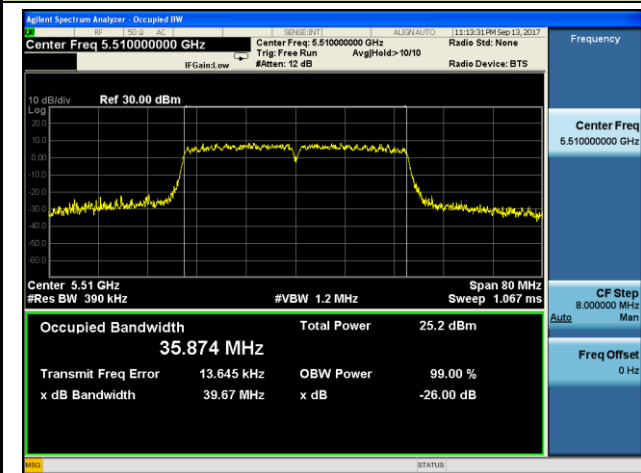
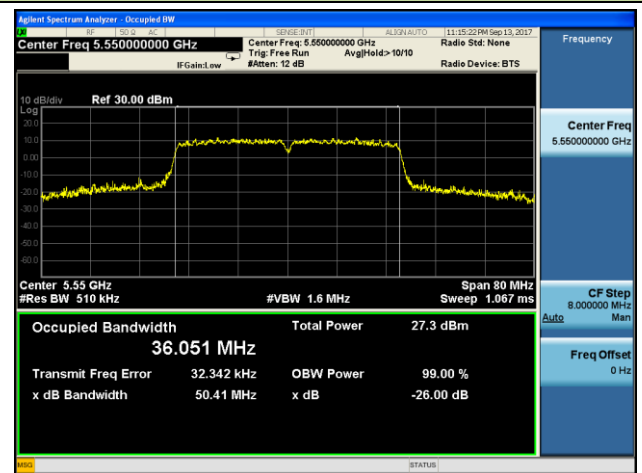
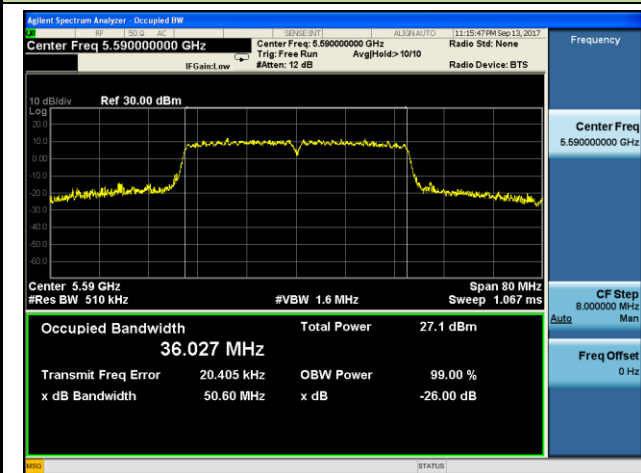
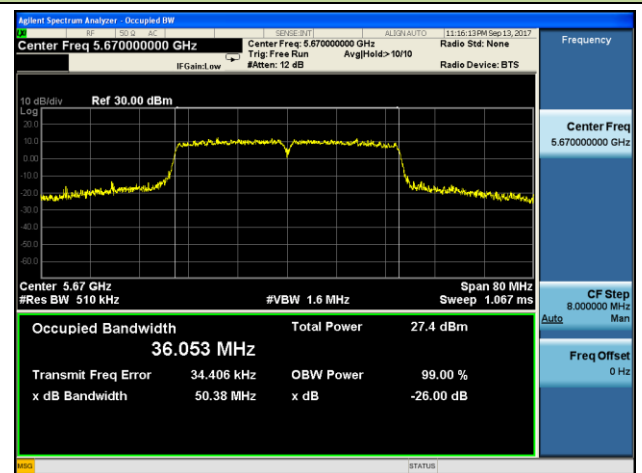
Channel 60 (5300MHz)

Channel 64 (5320MHz)

Channel 100 (5500MHz)

Channel 116 (5580MHz)

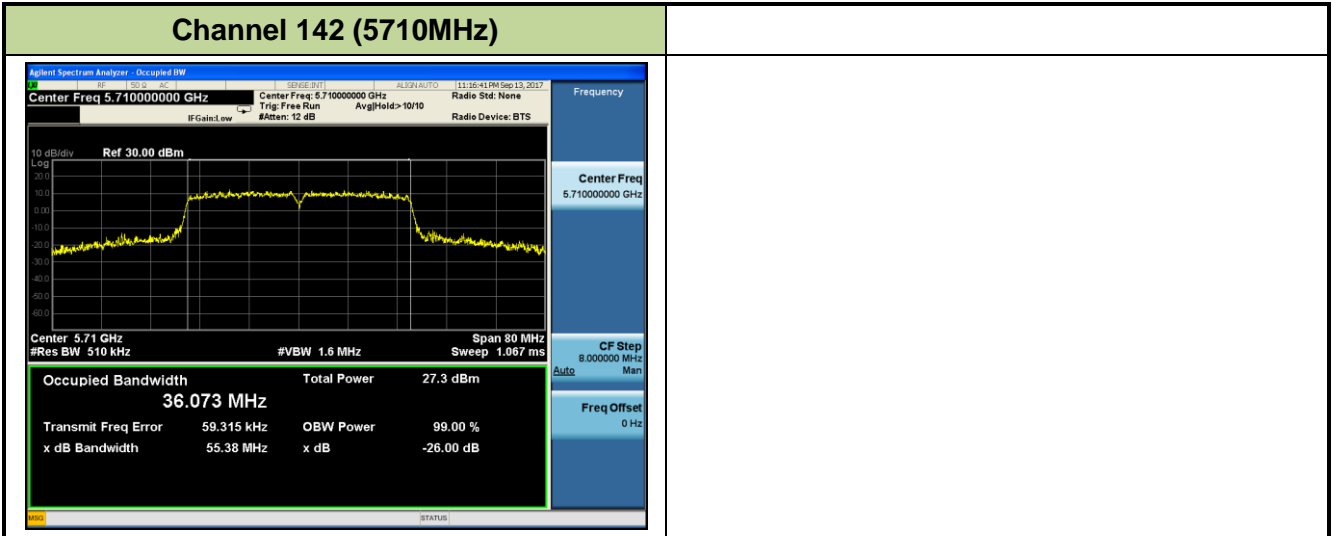
Channel 100 (5600MHz)



802.11n-HT20 26dB Bandwidth & 99% Bandwidth - Ant 2 / Ant 1 + 2
Channel 52 (5260MHz)

Channel 60 (5300MHz)

Channel 64 (5320MHz)

Channel 100 (5500MHz)

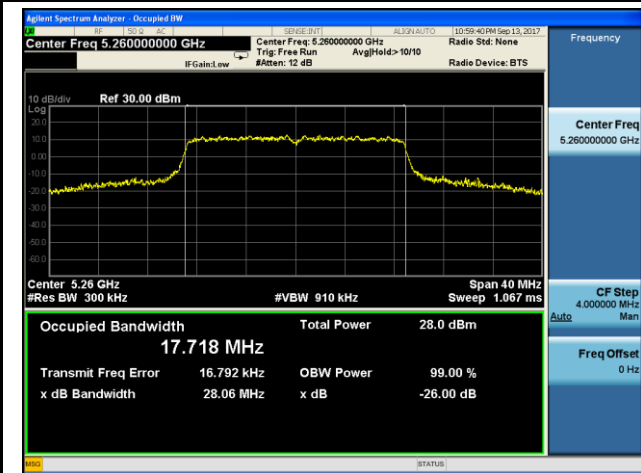
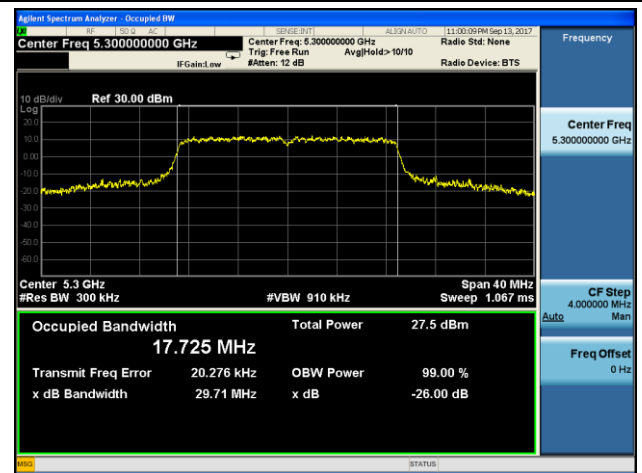
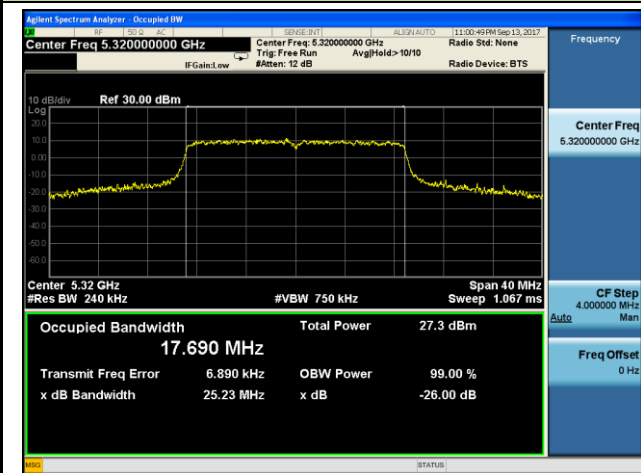
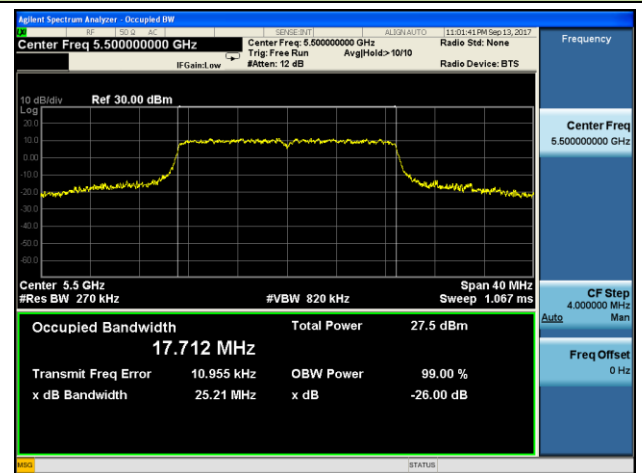
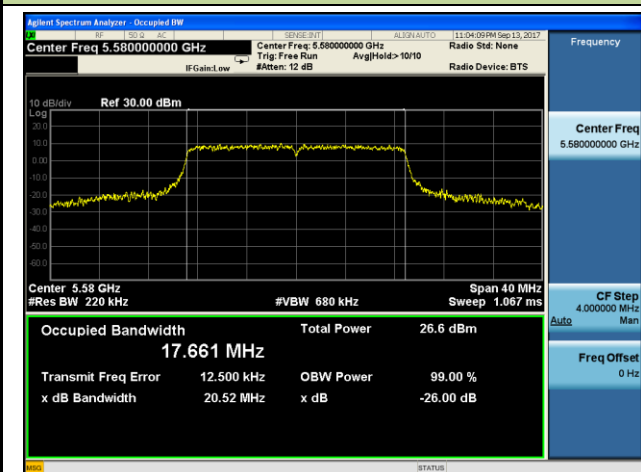
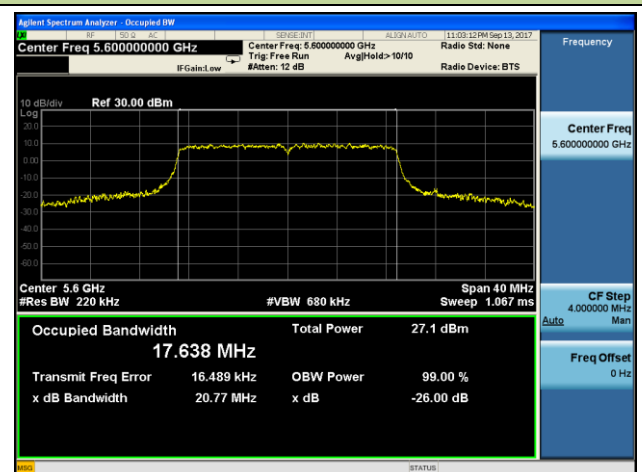
Channel 116 (5580MHz)

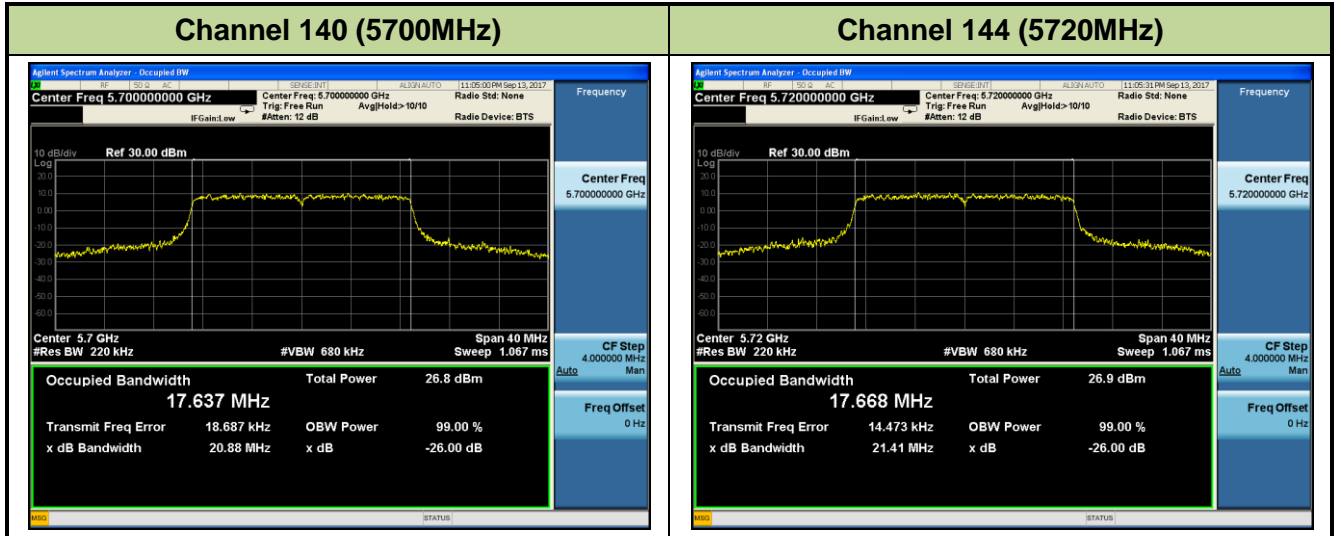
Channel 120 (5600MHz)



802.11n-HT40 26dB Bandwidth & 99% Bandwidth - Ant 2 / Ant 1 + 2
Channel 54 (5270MHz)

Channel 62 (5310MHz)

Channel 102 (5510MHz)

Channel 110 (5550MHz)

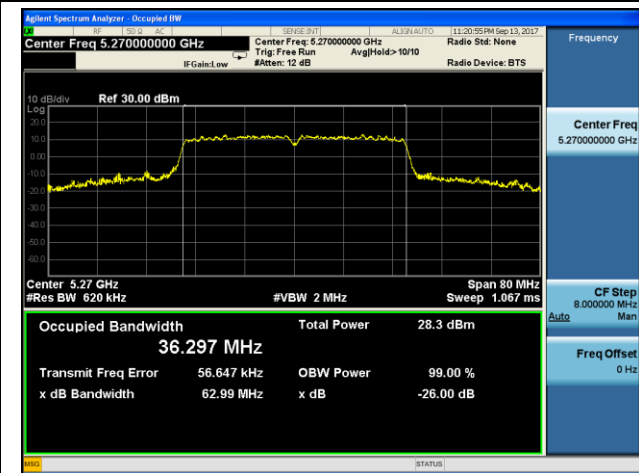
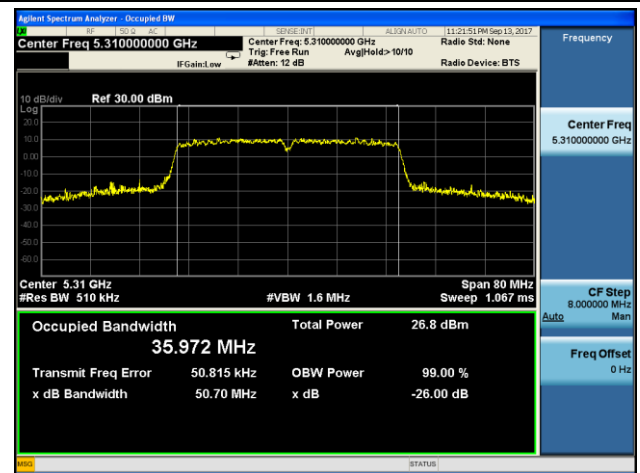
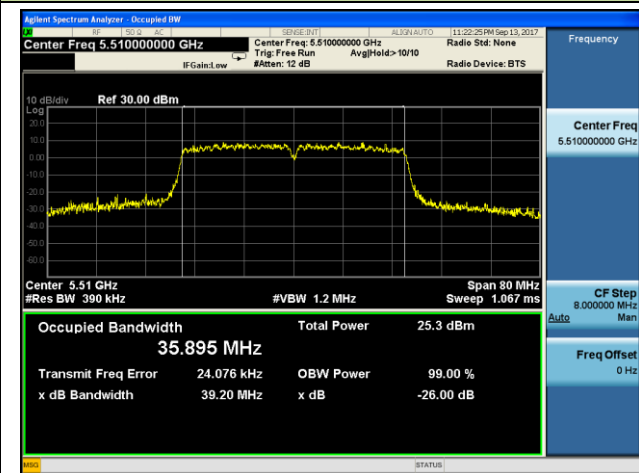
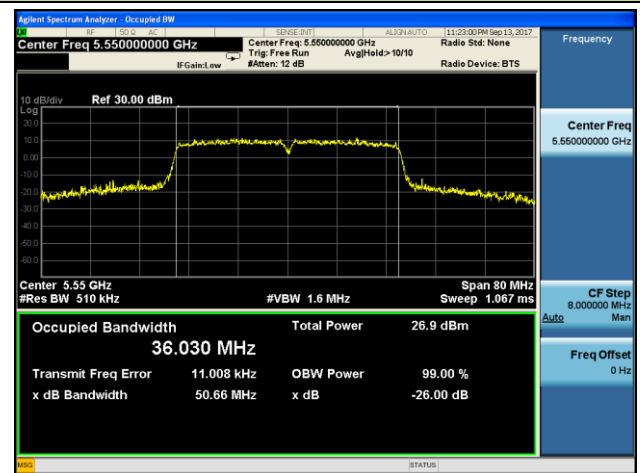
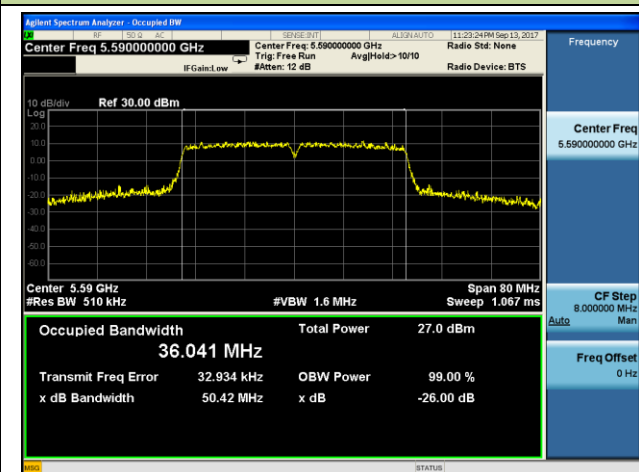
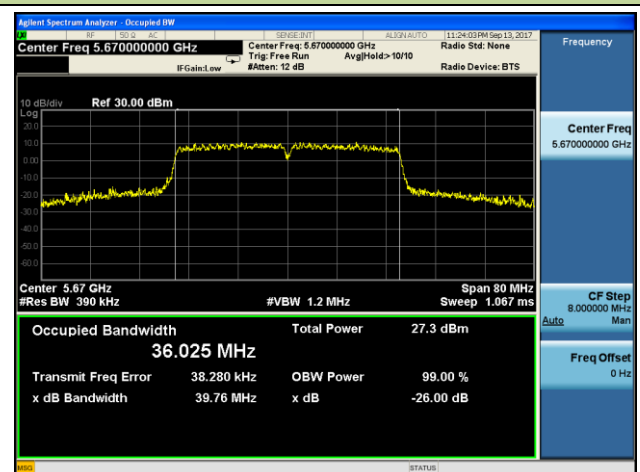
Channel 118 (5590MHz)

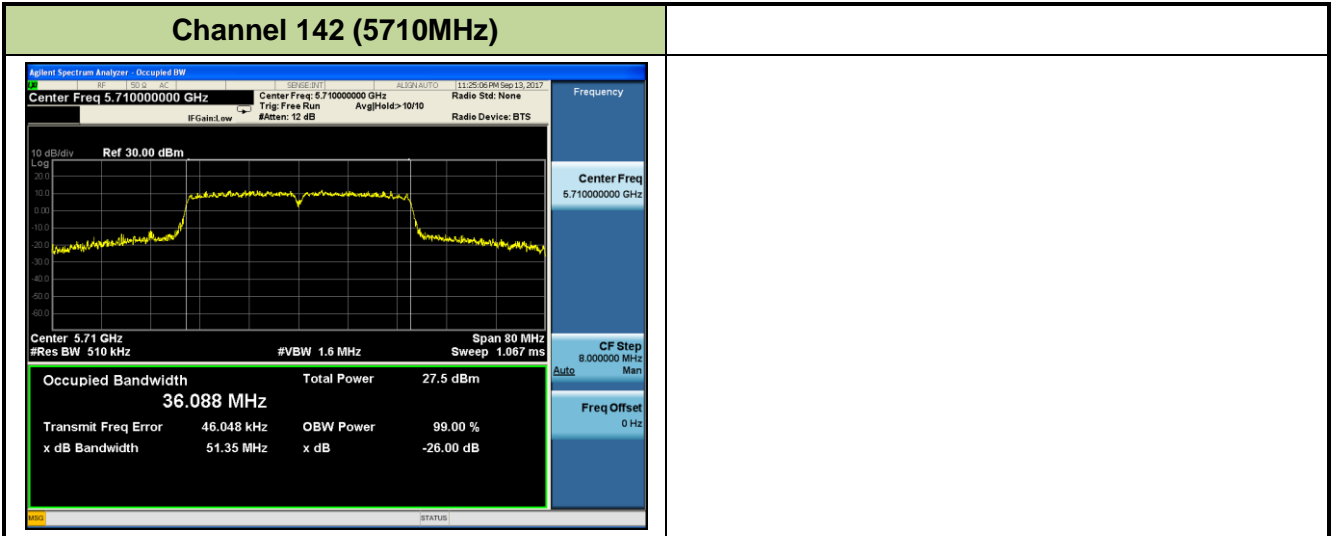
Channel 134 (5670MHz)



802.11ac-VHT20 26dB Bandwidth & 99% Bandwidth - Ant 2 / Ant 1 + 2
Channel 52 (5260MHz)

Channel 60 (5300MHz)

Channel 64 (5320MHz)

Channel 100 (5500MHz)

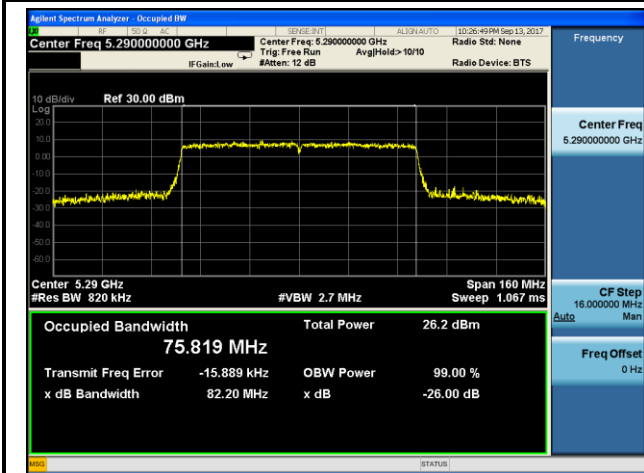
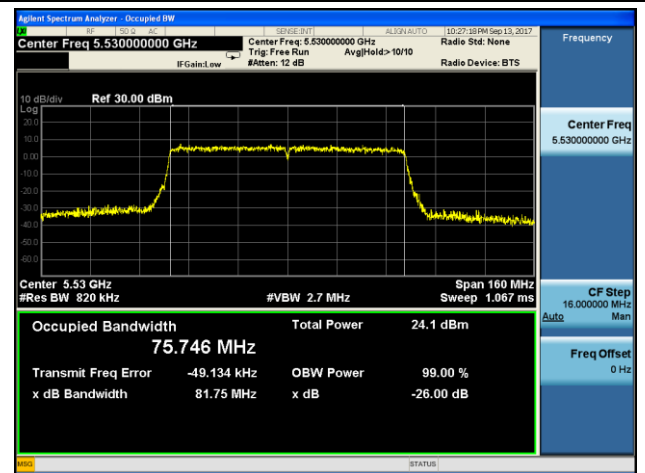
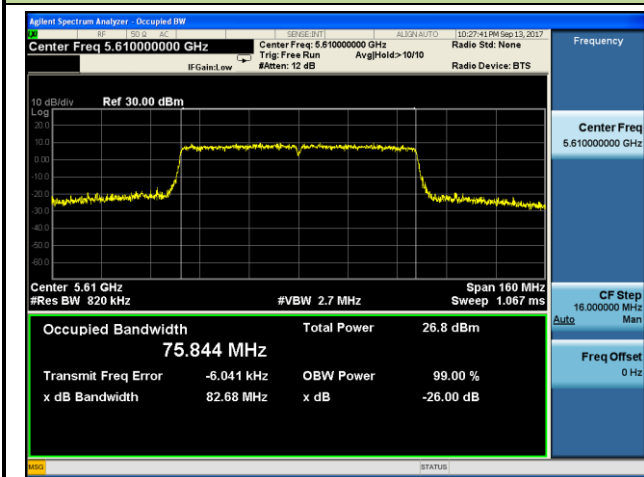
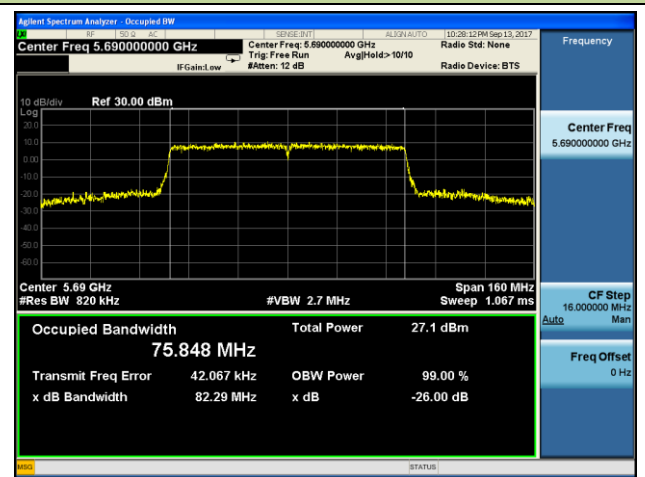
Channel 116 (5580MHz)

Channel 120 (5600MHz)



802.11ac-VHT40 26dB Bandwidth & 99% Bandwidth - Ant 2 / Ant 1 + 2
Channel 54 (5270MHz)

Channel 62 (5310MHz)

Channel 102 (5510MHz)

Channel 110 (5550MHz)

Channel 118 (5590MHz)

Channel 134 (5670MHz)



802.11ac-VHT80 26dB Bandwidth & 99% Bandwidth - Ant 2 / Ant 1 + 2
Channel 58 (5290MHz)

Channel 106 (5530MHz)

Channel 122 (5610MHz)

Channel 138 (5690MHz)

7.3. 6dB Bandwidth Measurement

7.3.1. Test Limit

The minimum 6dB bandwidth shall be at least 500 kHz.

7.3.2. Test Procedure used

ANSI C63.10-2013 - Section C.2

7.3.3. Test Setting

1. Set center frequency to the nominal EUT channel center frequency.
2. RBW = 100 kHz.
3. VBW $\geq 3 \times$ RBW.
4. Detector = Peak.
5. Trace mode = max hold.
6. Sweep = auto couple.
7. Allow the trace to stabilize.
8. Measure the maximum width of the emission that is constrained by the frequencies associated with the two outermost amplitude points (upper and lower frequencies) that are attenuated by 6 dB relative to the maximum level measured in the fundamental emission.

7.3.4. Test Setup

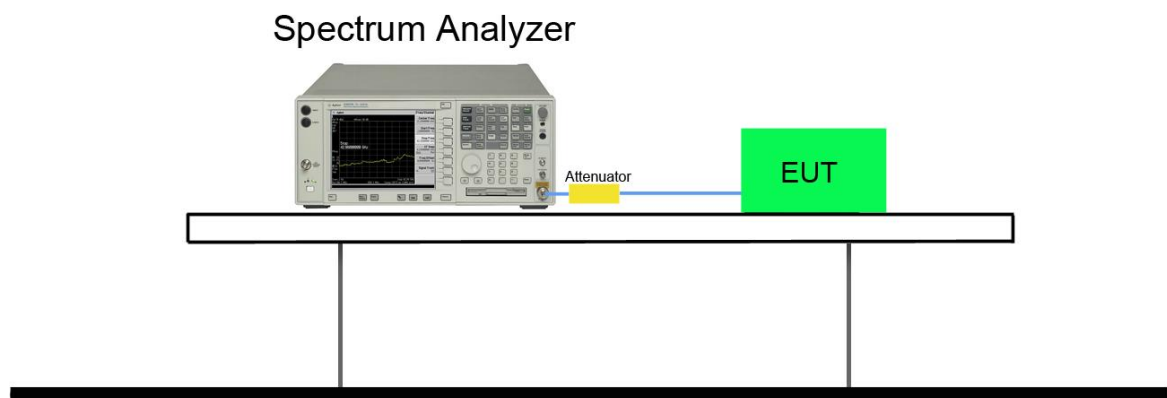

7.3.5. Test Result

Not Applicable with DFS Bands.

7.4. Output Power Measurement

7.4.1. Test Limit

For the 5.25-5.35 GHz and 5.47-5.725 GHz bands, the maximum conducted output power over the frequency bands of operation shall not exceed the lesser of 250 mW (23.98dBm) or 11dBm +10 log (26dB BW).

If transmitting antennas of directional gain greater than 6dBi are used, the maximum conducted output power shall be reduced by the amount in dB that the directional gain of the antenna exceeds 6dBi.

Output Power Measurement limit of AC220 Wi-Fi AP OD directional antenna US

Frequency Band (MHz)	Per Chain Max Antenna Gain (dBi)		Directional Gain (dBi)		Limit of SISO (dBm)		Limit of MIMO (dBm)	
	Ant 1	Ant 2	CDD	Beam-Forming	Ant 1	Ant 2	CDD	Beam-Forming
5250 ~ 5350	11.00	11.00	11.00	14.01	18.98	18.98	18.98	15.97
5470 ~ 5725	10.50	10.50	10.50	13.51	19.48	19.48	19.48	16.47

Output Power Measurement limit of AC220 Wi-Fi AP OD external antenna US

Frequency Band (MHz)	Per Chain Max Antenna Gain (dBi)		Directional Gain (dBi)		Limit of SISO (dBm)		Limit of MIMO (dBm)	
	Ant 1	Ant 2	CDD	Beam-Forming	Ant 1	Ant 2	CDD	Beam-Forming
5250 ~ 5350	5.00	5.00	5.00	8.01	23.98	23.98	23.98	21.97
5470 ~ 5725	5.00	5.00	5.00	8.01	23.98	23.98	23.98	21.97

Output Power Measurement limit of AC220 Wi-Fi AP OD small omni antenna US

Frequency Band (MHz)	Per Chain Max Antenna Gain (dBi)		Directional Gain (dBi)		Limit of SISO (dBm)		Limit of MIMO (dBm)	
	Ant 1	Ant 2	CDD	Beam-Forming	Ant 1	Ant 2	CDD	Beam-Forming
5250 ~ 5350	6.50	6.50	6.50	9.51	23.48	23.48	23.48	20.47
5470 ~ 5725	6.50	6.50	6.50	9.51	23.48	23.48	23.48	20.47

7.4.2. Test Procedure Used

KDB 789033D02v01r04- Section E)3)b) Method PM-G

7.4.3. Test Setting

Average power measurements were performed only when the EUT was transmitting at its maximum power control level using a broadband power meter with a pulse sensor. The power meter implemented triggering and gating capabilities which were set up such that power measurements were recorded only during the ON time of the transmitter. The trace was averaged over 100 traces to obtain the final measured average power.

7.4.4. Test Setup



7.4.5. Test Result

Product Name	AC220 Wi-Fi AP OD directional antenna US	Temperature	24°C
Test Engineer	Kevin Ker	Relative Humidity	59%
Test Site	SR2	Test Date	2017/08/20
Test Item	FCC Output Power Test		

Test Mode	Data Rate/ MCS	Channel No.	Freq. (MHz)	Average Power (dBm)	Power Limit (dBm)	Result
Ant 1						
11a	6Mbps	52	5260	16.61	≤ 18.98	Pass
11a	6Mbps	60	5300	16.72	≤ 18.98	Pass
11a	6Mbps	64	5320	17.08	≤ 18.98	Pass
11a	6Mbps	100	5500	16.81	≤ 19.48	Pass
11a	6Mbps	120	5600	17.11	≤ 19.48	Pass
11a	6Mbps	140	5700	16.89	≤ 19.48	Pass
11a	6Mbps	144	5720	16.75	≤ 19.48	Pass
11n-HT20	MCS0	52	5260	17.08	≤ 18.98	Pass
11n-HT20	MCS0	60	5300	17.37	≤ 18.98	Pass
11n-HT20	MCS0	64	5320	16.79	≤ 18.98	Pass
11n-HT20	MCS0	100	5500	16.88	≤ 19.48	Pass
11n-HT20	MCS0	120	5600	16.86	≤ 19.48	Pass
11n-HT20	MCS0	140	5700	16.99	≤ 19.48	Pass
11n-HT20	MCS0	144	5720	17.01	≤ 19.48	Pass
11n-HT40	MCS0	54	5270	18.48	≤ 18.98	Pass
11n-HT40	MCS0	62	5310	18.35	≤ 18.98	Pass
11n-HT40	MCS0	102	5510	18.98	≤ 19.48	Pass
11n-HT40	MCS0	110	5590	19.14	≤ 19.48	Pass
11n-HT40	MCS0	134	5670	19.00	≤ 19.48	Pass
11n-HT40	MCS0	142	5710	19.01	≤ 19.48	Pass

Test Mode	Data Rate/ MCS	Channel No.	Freq. (MHz)	Average Power (dBm)	Power Limit (dBm)	Result
Ant 1						
11ac-VHT20	MCS0	52	5260	16.86	≤ 18.98	Pass
11ac-VHT20	MCS0	60	5300	17.34	≤ 18.98	Pass
11ac-VHT20	MCS0	64	5320	17.21	≤ 18.98	Pass
11ac-VHT20	MCS0	100	5500	16.98	≤ 19.48	Pass
11ac-VHT20	MCS0	120	5600	16.91	≤ 19.48	Pass
11ac-VHT20	MCS0	140	5700	16.74	≤ 19.48	Pass
11ac-VHT20	MCS0	144	5720	16.65	≤ 19.48	Pass
11ac-VHT40	MCS0	54	5270	18.53	≤ 18.98	Pass
11ac-VHT40	MCS0	62	5310	18.44	≤ 18.98	Pass
11ac-VHT40	MCS0	102	5510	18.97	≤ 19.48	Pass
11ac-VHT40	MCS0	110	5590	19.23	≤ 19.48	Pass
11ac-VHT40	MCS0	134	5670	19.02	≤ 19.48	Pass
11ac-VHT40	MCS0	142	5710	18.98	≤ 19.48	Pass
11ac-VHT80	MCS0	58	5290	18.51	≤ 18.98	Pass
11ac-VHT80	MCS0	106	5530	19.10	≤ 19.48	Pass
11ac-VHT80	MCS0	122	5610	19.26	≤ 19.48	Pass
11ac-VHT80	MCS0	138	5690	19.11	≤ 19.48	Pass

Test Mode	Data Rate/ MCS	Channel No.	Freq. (MHz)	Average Power (dBm)	Power Limit (dBm)	Result
Ant 2						
11a	6Mbps	52	5260	17.44	≤ 18.98	Pass
11a	6Mbps	60	5300	17.06	≤ 18.98	Pass
11a	6Mbps	64	5320	17.13	≤ 18.98	Pass
11a	6Mbps	100	5500	16.82	≤ 19.48	Pass
11a	6Mbps	120	5600	16.85	≤ 19.48	Pass
11a	6Mbps	140	5700	16.72	≤ 19.48	Pass
11a	6Mbps	144	5720	16.64	≤ 19.48	Pass
11n-HT20	MCS0	52	5260	17.45	≤ 18.98	Pass
11n-HT20	MCS0	60	5300	17.32	≤ 18.98	Pass
11n-HT20	MCS0	64	5320	17.24	≤ 18.98	Pass
11n-HT20	MCS0	100	5500	16.88	≤ 19.48	Pass
11n-HT20	MCS0	120	5600	16.72	≤ 19.48	Pass
11n-HT20	MCS0	140	5700	16.58	≤ 19.48	Pass
11n-HT20	MCS0	144	5720	16.61	≤ 19.48	Pass
11n-HT40	MCS0	54	5270	18.48	≤ 18.98	Pass
11n-HT40	MCS0	62	5310	18.34	≤ 18.98	Pass
11n-HT40	MCS0	102	5510	19.21	≤ 19.48	Pass
11n-HT40	MCS0	110	5590	19.18	≤ 19.48	Pass
11n-HT40	MCS0	134	5670	19.01	≤ 19.48	Pass
11n-HT40	MCS0	142	5710	18.97	≤ 19.48	Pass



Test Mode	Data Rate/ MCS	Channel No.	Freq. (MHz)	Average Power (dBm)	Power Limit (dBm)	Result
Ant 2						
11ac-VHT20	MCS0	52	5260	17.42	≤ 18.98	Pass
11ac-VHT20	MCS0	60	5300	17.35	≤ 18.98	Pass
11ac-VHT20	MCS0	64	5320	17.15	≤ 18.98	Pass
11ac-VHT20	MCS0	100	5500	17.14	≤ 19.48	Pass
11ac-VHT20	MCS0	120	5600	16.95	≤ 19.48	Pass
11ac-VHT20	MCS0	140	5700	16.89	≤ 19.48	Pass
11ac-VHT20	MCS0	144	5720	16.78	≤ 19.48	Pass
11ac-VHT40	MCS0	54	5270	18.42	≤ 18.98	Pass
11ac-VHT40	MCS0	62	5310	18.39	≤ 18.98	Pass
11ac-VHT40	MCS0	102	5510	19.18	≤ 19.48	Pass
11ac-VHT40	MCS0	110	5590	19.14	≤ 19.48	Pass
11ac-VHT40	MCS0	134	5670	19.03	≤ 19.48	Pass
11ac-VHT40	MCS0	142	5710	18.78	≤ 19.48	Pass
11ac-VHT80	MCS0	58	5290	18.48	≤ 18.98	Pass
11ac-VHT80	MCS0	106	5530	19.24	≤ 19.48	Pass
11ac-VHT80	MCS0	122	5610	19.11	≤ 19.48	Pass
11ac-VHT80	MCS0	138	5690	18.97	≤ 19.48	Pass



Test Mode	Data Rate/ MCS	Channel No.	Freq. (MHz)	Ant1 Average Power (dBm)	Ant2 Average Power (dBm)	Total Average Power (dBm)	Power Limit (dBm)	Result
Ant 1 + 2 (CDD Mode)								
11a	6Mbps	52	5260	10.04	10.85	13.47	≤ 18.98	Pass
11a	6Mbps	60	5300	10.12	10.75	13.46	≤ 18.98	Pass
11a	6Mbps	64	5320	10.33	10.85	13.61	≤ 18.98	Pass
11a	6Mbps	100	5500	10.41	10.92	13.68	≤ 19.48	Pass
11a	6Mbps	120	5600	10.26	10.81	13.55	≤ 19.48	Pass
11a	6Mbps	140	5700	9.86	10.62	13.27	≤ 19.48	Pass
11a	6Mbps	144	5720	9.91	10.58	13.27	≤ 19.48	Pass
11n-HT20	MCS0	52	5260	10.56	11.01	13.80	≤ 18.98	Pass
11n-HT20	MCS0	60	5300	10.45	11.12	13.81	≤ 18.98	Pass
11n-HT20	MCS0	64	5320	10.65	10.78	13.73	≤ 18.98	Pass
11n-HT20	MCS0	100	5500	10.43	10.81	13.63	≤ 19.48	Pass
11n-HT20	MCS0	120	5600	10.74	11.23	14.00	≤ 19.48	Pass
11n-HT20	MCS0	140	5700	10.81	11.43	14.14	≤ 19.48	Pass
11n-HT20	MCS0	144	5720	10.68	11.35	14.04	≤ 19.48	Pass
11n-HT40	MCS0	54	5270	14.77	15.81	18.33	≤ 18.98	Pass
11n-HT40	MCS0	62	5310	14.81	15.79	18.34	≤ 18.98	Pass
11n-HT40	MCS0	102	5510	15.45	16.38	18.95	≤ 19.48	Pass
11n-HT40	MCS0	118	5590	15.61	16.37	19.02	≤ 19.48	Pass
11n-HT40	MCS0	134	5670	15.82	16.65	19.27	≤ 19.48	Pass
11n-HT40	MCS0	142	5710	15.56	16.71	19.18	≤ 19.48	Pass
11ac-VHT20	MCS0	52	5260	10.82	11.46	14.16	≤ 18.98	Pass
11ac-VHT20	MCS0	60	5300	10.86	11.52	14.21	≤ 18.98	Pass
11ac-VHT20	MCS0	64	5320	10.91	11.65	14.31	≤ 18.98	Pass
11ac-VHT20	MCS0	100	5500	10.88	11.78	14.36	≤ 19.48	Pass
11ac-VHT20	MCS0	120	5600	10.56	11.45	14.04	≤ 19.48	Pass
11ac-VHT20	MCS0	140	5700	10.43	11.23	13.86	≤ 19.48	Pass
11ac-VHT20	MCS0	144	5720	10.52	11.35	13.97	≤ 19.48	Pass

Test Mode	Data Rate/ MCS	Channel No.	Freq. (MHz)	Ant1 Average Power (dBm)	Ant2 Average Power (dBm)	Total Average Power (dBm)	Average Power Limit (dBm)	Result
Ant 1 + 2 (CDD Mode)								
11ac-VHT40	MCS0	54	5270	14.85	15.77	18.34	≤ 18.98	Pass
11ac-VHT40	MCS0	62	5310	14.69	15.86	18.32	≤ 18.98	Pass
11ac-VHT40	MCS0	102	5510	15.45	16.49	19.01	≤ 19.48	Pass
11ac-VHT40	MCS0	118	5590	15.71	16.45	19.11	≤ 19.48	Pass
11ac-VHT40	MCS0	134	5670	15.77	16.58	19.20	≤ 19.48	Pass
11ac-VHT40	MCS0	142	5710	15.61	16.81	19.26	≤ 19.48	Pass
11ac-VHT80	MCS0	58	5290	15.22	15.72	18.49	≤ 18.98	Pass
11ac-VHT80	MCS0	106	5530	15.95	16.45	19.22	≤ 19.48	Pass
11ac-VHT80	MCS0	122	5610	15.61	16.37	19.02	≤ 19.48	Pass
11ac-VHT80	MCS0	138	5690	15.86	16.34	19.12	≤ 19.48	Pass

Note: The Total Average Power (dBm) = $10 \cdot \log\{10^{(\text{Ant 1 Average Power} / 10)} + 10^{(\text{Ant 2 Average Power} / 10)}\}$.



Test Mode	Data Rate/ MCS	Channel No.	Freq. (MHz)	Ant1 Average Power (dBm)	Ant2 Average Power (dBm)	Total Average Power (dBm)	Power Limit (dBm)	Result
Ant 1 + 2 (Beam-Forming Mode)								
11n-HT20	MCS0	52	5260	10.56	11.01	13.80	≤ 15.97	Pass
11n-HT20	MCS0	60	5300	10.45	11.12	13.81	≤ 15.97	Pass
11n-HT20	MCS0	64	5320	10.65	10.78	13.73	≤ 15.97	Pass
11n-HT20	MCS0	100	5500	10.43	10.81	13.63	≤ 16.47	Pass
11n-HT20	MCS0	120	5600	10.74	11.23	14.00	≤ 16.47	Pass
11n-HT20	MCS0	140	5700	10.81	11.43	14.14	≤ 16.47	Pass
11n-HT20	MCS0	144	5720	10.68	11.35	14.04	≤ 16.47	Pass
11n-HT40	MCS0	54	5270	12.38	12.26	15.33	≤ 15.97	Pass
11n-HT40	MCS0	62	5310	12.25	12.07	15.17	≤ 15.97	Pass
11n-HT40	MCS0	102	5510	12.80	12.97	15.90	≤ 16.47	Pass
11n-HT40	MCS0	118	5590	12.55	12.53	15.55	≤ 16.47	Pass
11n-HT40	MCS0	134	5670	12.76	12.42	15.60	≤ 16.47	Pass
11n-HT40	MCS0	142	5710	13.00	13.34	16.18	≤ 16.47	Pass
11ac-VHT20	MCS0	52	5260	10.82	11.46	14.16	≤ 15.97	Pass
11ac-VHT20	MCS0	60	5300	10.86	11.52	14.21	≤ 15.97	Pass
11ac-VHT20	MCS0	64	5320	10.91	11.65	14.31	≤ 15.97	Pass
11ac-VHT20	MCS0	100	5500	10.88	11.78	14.36	≤ 16.47	Pass
11ac-VHT20	MCS0	120	5600	10.56	11.45	14.04	≤ 16.47	Pass
11ac-VHT20	MCS0	140	5700	10.43	11.23	13.86	≤ 16.47	Pass
11ac-VHT20	MCS0	144	5720	10.52	11.35	13.97	≤ 16.47	Pass
11ac-VHT40	MCS0	54	5270	12.02	12.17	15.11	≤ 15.97	Pass
11ac-VHT40	MCS0	62	5310	12.68	12.76	15.73	≤ 15.97	Pass
11ac-VHT40	MCS0	102	5510	12.74	13.01	15.89	≤ 16.47	Pass
11ac-VHT40	MCS0	118	5590	12.95	13.33	16.15	≤ 16.47	Pass
11ac-VHT40	MCS0	134	5670	12.55	12.75	15.66	≤ 16.47	Pass
11ac-VHT40	MCS0	142	5710	12.41	12.81	15.62	≤ 16.47	Pass
11ac-VHT80	MCS0	58	5290	12.53	12.70	15.63	≤ 15.97	Pass
11ac-VHT80	MCS0	106	5530	12.65	12.76	15.72	≤ 16.47	Pass
11ac-VHT80	MCS0	122	5610	12.88	13.20	16.05	≤ 16.47	Pass
11ac-VHT80	MCS0	138	5690	12.74	13.04	15.90	≤ 16.47	Pass

Note: The Total Average Power (dBm) = $10 \cdot \log\{10^{(\text{Ant 1 Average Power} / 10)} + 10^{(\text{Ant 2 Average Power} / 10)}\}$.



Product Name	AC220 Wi-Fi AP OD external antenna US	Temperature	24°C
Test Engineer	Kevin Ker	Relative Humidity	59%
Test Site	SR2	Test Date	2017/08/10
Test Item	FCC Output Power Test		

Test Mode	Data Rate/ MCS	Channel No.	Freq. (MHz)	Average Power (dBm)	Power Limit (dBm)	Result
Ant 1						
11a	6Mbps	52	5260	21.86	≤ 23.98	Pass
11a	6Mbps	60	5300	21.72	≤ 23.98	Pass
11a	6Mbps	64	5320	21.63	≤ 23.98	Pass
11a	6Mbps	100	5500	21.20	≤ 23.98	Pass
11a	6Mbps	120	5600	21.31	≤ 23.98	Pass
11a	6Mbps	140	5700	21.36	≤ 23.98	Pass
11a	6Mbps	144	5720	21.26	≤ 23.98	Pass
11n-HT20	MCS0	52	5260	21.93	≤ 23.98	Pass
11n-HT20	MCS0	60	5300	21.74	≤ 23.98	Pass
11n-HT20	MCS0	64	5320	21.67	≤ 23.98	Pass
11n-HT20	MCS0	100	5500	21.22	≤ 23.98	Pass
11n-HT20	MCS0	120	5600	21.36	≤ 23.98	Pass
11n-HT20	MCS0	140	5700	21.39	≤ 23.98	Pass
11n-HT20	MCS0	144	5720	21.73	≤ 23.98	Pass
11n-HT40	MCS0	54	5270	22.05	≤ 23.98	Pass
11n-HT40	MCS0	62	5310	20.88	≤ 23.98	Pass
11n-HT40	MCS0	102	5510	19.40	≤ 23.98	Pass
11n-HT40	MCS0	110	5590	21.63	≤ 23.98	Pass
11n-HT40	MCS0	134	5670	21.90	≤ 23.98	Pass
11n-HT40	MCS0	142	5710	21.91	≤ 23.98	Pass

Test Mode	Data Rate/ MCS	Channel No.	Freq. (MHz)	Average Power (dBm)	Power Limit (dBm)	Result
Ant 1						
11ac-VHT20	MCS0	52	5260	21.91	≤ 23.98	Pass
11ac-VHT20	MCS0	60	5300	21.75	≤ 23.98	Pass
11ac-VHT20	MCS0	64	5320	21.65	≤ 23.98	Pass
11ac-VHT20	MCS0	100	5500	21.21	≤ 23.98	Pass
11ac-VHT20	MCS0	120	5600	21.30	≤ 23.98	Pass
11ac-VHT20	MCS0	140	5700	21.40	≤ 23.98	Pass
11ac-VHT20	MCS0	144	5720	21.72	≤ 23.98	Pass
11ac-VHT40	MCS0	54	5270	22.05	≤ 23.98	Pass
11ac-VHT40	MCS0	62	5310	20.88	≤ 23.98	Pass
11ac-VHT40	MCS0	102	5510	19.37	≤ 23.98	Pass
11ac-VHT40	MCS0	110	5590	21.60	≤ 23.98	Pass
11ac-VHT40	MCS0	134	5670	21.90	≤ 23.98	Pass
11ac-VHT40	MCS0	142	5710	21.90	≤ 23.98	Pass
11ac-VHT80	MCS0	58	5290	20.56	≤ 23.98	Pass
11ac-VHT80	MCS0	106	5530	18.54	≤ 23.98	Pass
11ac-VHT80	MCS0	122	5610	21.05	≤ 23.98	Pass
11ac-VHT80	MCS0	138	5690	21.70	≤ 23.98	Pass

Test Mode	Data Rate/ MCS	Channel No.	Freq. (MHz)	Average Power (dBm)	Power Limit (dBm)	Result
Ant 2						
11a	6Mbps	52	5260	21.75	≤ 23.98	Pass
11a	6Mbps	60	5300	21.62	≤ 23.98	Pass
11a	6Mbps	64	5320	21.39	≤ 23.98	Pass
11a	6Mbps	100	5500	21.05	≤ 23.98	Pass
11a	6Mbps	120	5600	20.81	≤ 23.98	Pass
11a	6Mbps	140	5700	21.32	≤ 23.98	Pass
11a	6Mbps	144	5720	21.11	≤ 23.98	Pass
11n-HT20	MCS0	52	5260	21.81	≤ 23.98	Pass
11n-HT20	MCS0	60	5300	21.66	≤ 23.98	Pass
11n-HT20	MCS0	64	5320	21.48	≤ 23.98	Pass
11n-HT20	MCS0	100	5500	21.54	≤ 23.98	Pass
11n-HT20	MCS0	120	5600	21.30	≤ 23.98	Pass
11n-HT20	MCS0	140	5700	21.76	≤ 23.98	Pass
11n-HT20	MCS0	144	5720	21.54	≤ 23.98	Pass
11n-HT40	MCS0	54	5270	22.49	≤ 23.98	Pass
11n-HT40	MCS0	62	5310	20.38	≤ 23.98	Pass
11n-HT40	MCS0	102	5510	19.67	≤ 23.98	Pass
11n-HT40	MCS0	110	5590	21.88	≤ 23.98	Pass
11n-HT40	MCS0	134	5670	22.29	≤ 23.98	Pass
11n-HT40	MCS0	142	5710	22.35	≤ 23.98	Pass

Test Mode	Data Rate/ MCS	Channel No.	Freq. (MHz)	Average Power (dBm)	Power Limit (dBm)	Result
Ant 2						
11ac-VHT20	MCS0	52	5260	21.82	≤ 23.98	Pass
11ac-VHT20	MCS0	60	5300	21.68	≤ 23.98	Pass
11ac-VHT20	MCS0	64	5320	21.97	≤ 23.98	Pass
11ac-VHT20	MCS0	100	5500	21.55	≤ 23.98	Pass
11ac-VHT20	MCS0	120	5600	21.30	≤ 23.98	Pass
11ac-VHT20	MCS0	140	5700	21.76	≤ 23.98	Pass
11ac-VHT20	MCS0	144	5720	21.54	≤ 23.98	Pass
11ac-VHT40	MCS0	54	5270	22.48	≤ 23.98	Pass
11ac-VHT40	MCS0	62	5310	20.92	≤ 23.98	Pass
11ac-VHT40	MCS0	102	5510	20.20	≤ 23.98	Pass
11ac-VHT40	MCS0	110	5590	21.90	≤ 23.98	Pass
11ac-VHT40	MCS0	134	5670	22.30	≤ 23.98	Pass
11ac-VHT40	MCS0	142	5710	22.38	≤ 23.98	Pass
11ac-VHT80	MCS0	58	5290	20.04	≤ 23.98	Pass
11ac-VHT80	MCS0	106	5530	19.20	≤ 23.98	Pass
11ac-VHT80	MCS0	122	5610	21.56	≤ 23.98	Pass
11ac-VHT80	MCS0	138	5690	22.02	≤ 23.98	Pass



Test Mode	Data Rate/ MCS	Channel No.	Freq. (MHz)	Ant1 Average Power (dBm)	Ant2 Average Power (dBm)	Total Average Power (dBm)	Power Limit (dBm)	Result
Ant 1 + 2 (CDD Mode)								
11a	6Mbps	52	5260	16.25	16.90	19.60	≤ 23.98	Pass
11a	6Mbps	60	5300	16.68	17.11	19.91	≤ 23.98	Pass
11a	6Mbps	64	5320	16.85	17.54	20.22	≤ 23.98	Pass
11a	6Mbps	100	5500	15.56	16.53	19.08	≤ 23.98	Pass
11a	6Mbps	120	5600	15.65	16.23	18.96	≤ 23.98	Pass
11a	6Mbps	140	5700	16.14	16.68	19.43	≤ 23.98	Pass
11a	6Mbps	144	5720	16.05	16.54	19.31	≤ 23.98	Pass
11n-HT20	MCS0	52	5260	16.88	17.35	20.13	≤ 23.98	Pass
11n-HT20	MCS0	60	5300	16.68	17.20	19.96	≤ 23.98	Pass
11n-HT20	MCS0	64	5320	16.85	17.55	20.22	≤ 23.98	Pass
11n-HT20	MCS0	100	5500	16.03	17.00	19.55	≤ 23.98	Pass
11n-HT20	MCS0	120	5600	16.10	16.80	19.47	≤ 23.98	Pass
11n-HT20	MCS0	140	5700	16.17	16.77	19.49	≤ 23.98	Pass
11n-HT20	MCS0	144	5720	16.03	16.62	19.35	≤ 23.98	Pass
11n-HT40	MCS0	54	5270	19.26	19.87	22.59	≤ 23.98	Pass
11n-HT40	MCS0	62	5310	19.58	20.24	22.93	≤ 23.98	Pass
11n-HT40	MCS0	102	5510	18.57	19.43	22.03	≤ 23.98	Pass
11n-HT40	MCS0	118	5590	18.83	19.29	22.08	≤ 23.98	Pass
11n-HT40	MCS0	134	5670	19.20	19.73	22.48	≤ 23.98	Pass
11n-HT40	MCS0	142	5710	18.80	19.23	22.03	≤ 23.98	Pass
11ac-VHT20	MCS0	52	5260	16.83	17.33	20.10	≤ 23.98	Pass
11ac-VHT20	MCS0	60	5300	16.65	17.13	19.91	≤ 23.98	Pass
11ac-VHT20	MCS0	64	5320	16.83	17.57	20.23	≤ 23.98	Pass
11ac-VHT20	MCS0	100	5500	16.04	16.90	19.50	≤ 23.98	Pass
11ac-VHT20	MCS0	120	5600	16.12	16.70	19.43	≤ 23.98	Pass
11ac-VHT20	MCS0	140	5700	16.14	16.77	19.48	≤ 23.98	Pass
11ac-VHT20	MCS0	144	5720	16.03	16.58	19.32	≤ 23.98	Pass

Test Mode	Data Rate/ MCS	Channel No.	Freq. (MHz)	Ant1 Average Power (dBm)	Ant2 Average Power (dBm)	Total Average Power (dBm)	Average Power Limit (dBm)	Result
Ant 1 + 2 (CDD Mode)								
11ac-VHT40	MCS0	54	5270	19.78	20.37	23.10	≤ 23.98	Pass
11ac-VHT40	MCS0	62	5310	19.58	20.23	22.93	≤ 23.98	Pass
11ac-VHT40	MCS0	102	5510	18.55	19.51	22.07	≤ 23.98	Pass
11ac-VHT40	MCS0	118	5590	18.80	19.36	22.10	≤ 23.98	Pass
11ac-VHT40	MCS0	134	5670	19.18	19.78	22.50	≤ 23.98	Pass
11ac-VHT40	MCS0	142	5710	19.23	19.80	22.53	≤ 23.98	Pass
11ac-VHT80	MCS0	58	5290	19.95	20.31	23.14	≤ 23.98	Pass
11ac-VHT80	MCS0	106	5530	17.35	18.15	20.78	≤ 23.98	Pass
11ac-VHT80	MCS0	122	5610	20.31	20.93	23.64	≤ 23.98	Pass
11ac-VHT80	MCS0	138	5690	20.44	20.98	23.73	≤ 23.98	Pass

Note: The Total Average Power (dBm) = $10 \cdot \log\{10^{(\text{Ant 1 Average Power} / 10)} + 10^{(\text{Ant 2 Average Power} / 10)}\}$.



Test Mode	Data Rate/ MCS	Channel No.	Freq. (MHz)	Ant1 Average Power (dBm)	Ant2 Average Power (dBm)	Total Average Power (dBm)	Power Limit (dBm)	Result
Ant 1 + 2 (Beam-Forming Mode)								
11n-HT20	MCS0	52	5260	16.88	17.35	20.13	≤ 21.97	Pass
11n-HT20	MCS0	60	5300	16.68	17.20	19.96	≤ 21.97	Pass
11n-HT20	MCS0	64	5320	16.85	17.55	20.22	≤ 21.97	Pass
11n-HT20	MCS0	100	5500	16.03	17.00	19.55	≤ 21.97	Pass
11n-HT20	MCS0	120	5600	16.10	16.80	19.47	≤ 21.97	Pass
11n-HT20	MCS0	140	5700	16.17	16.77	19.49	≤ 21.97	Pass
11n-HT20	MCS0	144	5720	16.03	16.62	19.35	≤ 21.97	Pass
11n-HT40	MCS0	54	5270	18.24	18.64	21.45	≤ 21.97	Pass
11n-HT40	MCS0	62	5310	18.04	18.72	21.40	≤ 21.97	Pass
11n-HT40	MCS0	102	5510	18.03	19.04	21.57	≤ 21.97	Pass
11n-HT40	MCS0	118	5590	18.16	18.95	21.58	≤ 21.97	Pass
11n-HT40	MCS0	134	5670	18.12	18.82	21.49	≤ 21.97	Pass
11n-HT40	MCS0	142	5710	18.21	18.75	21.50	≤ 21.97	Pass
11ac-VHT20	MCS0	52	5260	16.83	17.33	20.10	≤ 21.97	Pass
11ac-VHT20	MCS0	60	5300	16.65	17.13	19.91	≤ 21.97	Pass
11ac-VHT20	MCS0	64	5320	16.83	17.57	20.23	≤ 21.97	Pass
11ac-VHT20	MCS0	100	5500	16.04	16.90	19.50	≤ 21.97	Pass
11ac-VHT20	MCS0	120	5600	16.12	16.70	19.43	≤ 21.97	Pass
11ac-VHT20	MCS0	140	5700	16.14	16.77	19.48	≤ 21.97	Pass
11ac-VHT20	MCS0	144	5720	16.03	16.58	19.32	≤ 21.97	Pass
11ac-VHT40	MCS0	54	5270	18.18	18.77	21.50	≤ 21.97	Pass
11ac-VHT40	MCS0	62	5310	18.02	18.62	21.34	≤ 21.97	Pass
11ac-VHT40	MCS0	102	5510	17.92	19.04	21.53	≤ 21.97	Pass
11ac-VHT40	MCS0	118	5590	18.22	18.97	21.62	≤ 21.97	Pass
11ac-VHT40	MCS0	134	5670	18.15	18.83	21.51	≤ 21.97	Pass
11ac-VHT40	MCS0	142	5710	18.22	18.81	21.54	≤ 21.97	Pass
11ac-VHT80	MCS0	58	5290	18.25	18.81	21.55	≤ 21.97	Pass
11ac-VHT80	MCS0	106	5530	17.96	18.63	21.32	≤ 21.97	Pass
11ac-VHT80	MCS0	122	5610	18.11	18.54	21.34	≤ 21.97	Pass
11ac-VHT80	MCS0	138	5690	18.25	18.53	21.40	≤ 21.97	Pass

Note: The Total Average Power (dBm) = $10 \cdot \log\{10^{(\text{Ant 1 Average Power} / 10)} + 10^{(\text{Ant 2 Average Power} / 10)}\}$.



Product Name	AC220 Wi-Fi AP OD small omni antenna US	Temperature	24°C
Test Engineer	Kevin Ker	Relative Humidity	59%
Test Site	SR2	Test Date	2017/08/21
Test Item	FCC Output Power Test		

Test Mode	Data Rate/ MCS	Channel No.	Freq. (MHz)	Average Power (dBm)	Power Limit (dBm)	Result
Ant 1						
11a	6Mbps	52	5260	21.34	≤ 23.48	Pass
11a	6Mbps	60	5300	21.17	≤ 23.48	Pass
11a	6Mbps	64	5320	21.11	≤ 23.48	Pass
11a	6Mbps	100	5500	20.70	≤ 23.48	Pass
11a	6Mbps	120	5600	20.38	≤ 23.48	Pass
11a	6Mbps	140	5700	20.81	≤ 23.48	Pass
11a	6Mbps	144	5720	20.64	≤ 23.48	Pass
11n-HT20	MCS0	52	5260	21.47	≤ 23.48	Pass
11n-HT20	MCS0	60	5300	21.28	≤ 23.48	Pass
11n-HT20	MCS0	64	5320	21.22	≤ 23.48	Pass
11n-HT20	MCS0	100	5500	20.82	≤ 23.48	Pass
11n-HT20	MCS0	120	5600	20.49	≤ 23.48	Pass
11n-HT20	MCS0	140	5700	20.92	≤ 23.48	Pass
11n-HT20	MCS0	144	5720	20.76	≤ 23.48	Pass
11n-HT40	MCS0	54	5270	22.03	≤ 23.48	Pass
11n-HT40	MCS0	62	5310	19.86	≤ 23.48	Pass
11n-HT40	MCS0	102	5510	18.91	≤ 23.48	Pass
11n-HT40	MCS0	110	5590	21.72	≤ 23.48	Pass
11n-HT40	MCS0	134	5670	21.94	≤ 23.48	Pass
11n-HT40	MCS0	142	5710	21.95	≤ 23.48	Pass

Test Mode	Data Rate/ MCS	Channel No.	Freq. (MHz)	Average Power (dBm)	Power Limit (dBm)	Result
Ant 1						
11ac-VHT20	MCS0	52	5260	21.46	≤ 23.48	Pass
11ac-VHT20	MCS0	60	5300	21.28	≤ 23.48	Pass
11ac-VHT20	MCS0	64	5320	21.67	≤ 23.48	Pass
11ac-VHT20	MCS0	100	5500	20.81	≤ 23.48	Pass
11ac-VHT20	MCS0	120	5600	21.00	≤ 23.48	Pass
11ac-VHT20	MCS0	140	5700	20.92	≤ 23.48	Pass
11ac-VHT20	MCS0	144	5720	20.78	≤ 23.48	Pass
11ac-VHT40	MCS0	54	5270	22.03	≤ 23.48	Pass
11ac-VHT40	MCS0	62	5310	19.85	≤ 23.48	Pass
11ac-VHT40	MCS0	102	5510	18.93	≤ 23.48	Pass
11ac-VHT40	MCS0	110	5590	21.75	≤ 23.48	Pass
11ac-VHT40	MCS0	134	5670	21.98	≤ 23.48	Pass
11ac-VHT40	MCS0	142	5710	21.92	≤ 23.48	Pass
11ac-VHT80	MCS0	58	5290	19.57	≤ 23.48	Pass
11ac-VHT80	MCS0	106	5530	17.57	≤ 23.48	Pass
11ac-VHT80	MCS0	122	5610	21.07	≤ 23.48	Pass
11ac-VHT80	MCS0	138	5690	21.74	≤ 23.48	Pass

Test Mode	Data Rate/ MCS	Channel No.	Freq. (MHz)	Average Power (dBm)	Power Limit (dBm)	Result
Ant 2						
11a	6Mbps	52	5260	20.91	≤ 23.48	Pass
11a	6Mbps	60	5300	21.17	≤ 23.48	Pass
11a	6Mbps	64	5320	20.85	≤ 23.48	Pass
11a	6Mbps	100	5500	19.69	≤ 23.48	Pass
11a	6Mbps	120	5600	20.05	≤ 23.48	Pass
11a	6Mbps	140	5700	20.66	≤ 23.48	Pass
11a	6Mbps	144	5720	20.31	≤ 23.48	Pass
11n-HT20	MCS0	52	5260	21.54	≤ 23.48	Pass
11n-HT20	MCS0	60	5300	21.31	≤ 23.48	Pass
11n-HT20	MCS0	64	5320	20.99	≤ 23.48	Pass
11n-HT20	MCS0	100	5500	19.82	≤ 23.48	Pass
11n-HT20	MCS0	120	5600	20.18	≤ 23.48	Pass
11n-HT20	MCS0	140	5700	20.25	≤ 23.48	Pass
11n-HT20	MCS0	144	5720	20.41	≤ 23.48	Pass
11n-HT40	MCS0	54	5270	22.15	≤ 23.48	Pass
11n-HT40	MCS0	62	5310	19.92	≤ 23.48	Pass
11n-HT40	MCS0	102	5510	18.37	≤ 23.48	Pass
11n-HT40	MCS0	110	5590	21.12	≤ 23.48	Pass
11n-HT40	MCS0	134	5670	21.87	≤ 23.48	Pass
11n-HT40	MCS0	142	5710	21.72	≤ 23.48	Pass



Test Mode	Data Rate/ MCS	Channel No.	Freq. (MHz)	Average Power (dBm)	Power Limit (dBm)	Result
Ant 2						
11ac-VHT20	MCS0	52	5260	21.04	≤ 23.48	Pass
11ac-VHT20	MCS0	60	5300	21.30	≤ 23.48	Pass
11ac-VHT20	MCS0	64	5320	20.97	≤ 23.48	Pass
11ac-VHT20	MCS0	100	5500	20.25	≤ 23.48	Pass
11ac-VHT20	MCS0	120	5600	20.17	≤ 23.48	Pass
11ac-VHT20	MCS0	140	5700	19.98	≤ 23.48	Pass
11ac-VHT20	MCS0	144	5720	20.11	≤ 23.48	Pass
11ac-VHT40	MCS0	54	5270	22.15	≤ 23.48	Pass
11ac-VHT40	MCS0	62	5310	19.92	≤ 23.48	Pass
11ac-VHT40	MCS0	102	5510	18.89	≤ 23.48	Pass
11ac-VHT40	MCS0	110	5590	21.14	≤ 23.48	Pass
11ac-VHT40	MCS0	134	5670	21.88	≤ 23.48	Pass
11ac-VHT40	MCS0	142	5710	21.71	≤ 23.48	Pass
11ac-VHT80	MCS0	58	5290	19.68	≤ 23.48	Pass
11ac-VHT80	MCS0	106	5530	17.86	≤ 23.48	Pass
11ac-VHT80	MCS0	122	5610	21.52	≤ 23.48	Pass
11ac-VHT80	MCS0	138	5690	22.03	≤ 23.48	Pass



Test Mode	Data Rate/ MCS	Channel No.	Freq. (MHz)	Ant1 Average Power (dBm)	Ant2 Average Power (dBm)	Total Average Power (dBm)	Power Limit (dBm)	Result
Ant 1 + 2 (CDD Mode)								
11a	6Mbps	52	5260	14.78	15.75	18.30	≤ 23.48	Pass
11a	6Mbps	60	5300	14.63	15.54	18.12	≤ 23.48	Pass
11a	6Mbps	64	5320	14.53	15.23	17.90	≤ 23.48	Pass
11a	6Mbps	100	5500	14.31	15.21	17.79	≤ 23.48	Pass
11a	6Mbps	120	5600	14.34	15.04	17.71	≤ 23.48	Pass
11a	6Mbps	140	5700	14.29	14.98	17.66	≤ 23.48	Pass
11a	6Mbps	144	5720	14.14	14.72	17.45	≤ 23.48	Pass
11n-HT20	MCS0	52	5260	15.02	15.86	18.47	≤ 23.48	Pass
11n-HT20	MCS0	60	5300	14.82	15.34	18.10	≤ 23.48	Pass
11n-HT20	MCS0	64	5320	15.11	15.76	18.46	≤ 23.48	Pass
11n-HT20	MCS0	100	5500	14.48	15.28	17.91	≤ 23.48	Pass
11n-HT20	MCS0	120	5600	14.61	15.22	17.94	≤ 23.48	Pass
11n-HT20	MCS0	140	5700	14.42	14.93	17.69	≤ 23.48	Pass
11n-HT20	MCS0	144	5720	14.35	14.88	17.63	≤ 23.48	Pass
11n-HT40	MCS0	54	5270	18.02	18.75	21.41	≤ 23.48	Pass
11n-HT40	MCS0	62	5310	17.74	18.59	21.20	≤ 23.48	Pass
11n-HT40	MCS0	102	5510	17.45	18.27	20.89	≤ 23.48	Pass
11n-HT40	MCS0	118	5590	17.31	17.84	20.59	≤ 23.48	Pass
11n-HT40	MCS0	134	5670	17.41	18.17	20.82	≤ 23.48	Pass
11n-HT40	MCS0	142	5710	17.54	18.10	20.84	≤ 23.48	Pass
11ac-VHT20	MCS0	52	5260	14.96	15.86	18.44	≤ 23.48	Pass
11ac-VHT20	MCS0	60	5300	15.33	16.02	18.70	≤ 23.48	Pass
11ac-VHT20	MCS0	64	5320	15.12	15.89	18.53	≤ 23.48	Pass
11ac-VHT20	MCS0	100	5500	14.43	15.15	17.82	≤ 23.48	Pass
11ac-VHT20	MCS0	120	5600	14.53	15.25	17.92	≤ 23.48	Pass
11ac-VHT20	MCS0	140	5700	14.43	15.16	17.82	≤ 23.48	Pass
11ac-VHT20	MCS0	144	5720	14.21	14.85	17.55	≤ 23.48	Pass

Test Mode	Data Rate/ MCS	Channel No.	Freq. (MHz)	Ant1 Average Power (dBm)	Ant2 Average Power (dBm)	Total Average Power (dBm)	Average Power Limit (dBm)	Result
Ant 1 + 2 (CDD Mode)								
11ac-VHT40	MCS0	54	5270	17.94	18.73	21.36	≤ 23.48	Pass
11ac-VHT40	MCS0	62	5310	17.94	18.57	21.28	≤ 23.48	Pass
11ac-VHT40	MCS0	102	5510	17.50	18.32	20.94	≤ 23.48	Pass
11ac-VHT40	MCS0	118	5590	17.18	17.83	20.53	≤ 23.48	Pass
11ac-VHT40	MCS0	134	5670	16.99	18.16	20.62	≤ 23.48	Pass
11ac-VHT40	MCS0	142	5710	17.35	18.08	20.74	≤ 23.48	Pass
11ac-VHT80	MCS0	58	5290	18.65	19.30	22.00	≤ 23.48	Pass
11ac-VHT80	MCS0	106	5530	16.10	16.93	19.55	≤ 23.48	Pass
11ac-VHT80	MCS0	122	5610	19.59	20.41	23.03	≤ 23.48	Pass
11ac-VHT80	MCS0	138	5690	19.78	20.38	23.10	≤ 23.48	Pass

Note: The Total Average Power (dBm) = $10 \cdot \log\{10^{(\text{Ant 1 Average Power} / 10)} + 10^{(\text{Ant 2 Average Power} / 10)}\}$.



Test Mode	Data Rate/ MCS	Channel No.	Freq. (MHz)	Ant1 Average Power (dBm)	Ant2 Average Power (dBm)	Total Average Power (dBm)	Power Limit (dBm)	Result
Ant 1 + 2 (Beam-Forming Mode)								
11n-HT20	MCS0	52	5260	15.02	15.86	18.47	≤ 20.47	Pass
11n-HT20	MCS0	60	5300	14.82	15.34	18.10	≤ 20.47	Pass
11n-HT20	MCS0	64	5320	15.11	15.76	18.46	≤ 20.47	Pass
11n-HT20	MCS0	100	5500	14.48	15.28	17.91	≤ 20.47	Pass
11n-HT20	MCS0	120	5600	14.61	15.22	17.94	≤ 20.47	Pass
11n-HT20	MCS0	140	5700	14.42	14.93	17.69	≤ 20.47	Pass
11n-HT20	MCS0	144	5720	14.35	14.88	17.63	≤ 20.47	Pass
11n-HT40	MCS0	54	5270	16.34	16.90	19.64	≤ 20.47	Pass
11n-HT40	MCS0	62	5310	16.16	16.76	19.48	≤ 20.47	Pass
11n-HT40	MCS0	102	5510	16.12	17.15	19.68	≤ 20.47	Pass
11n-HT40	MCS0	118	5590	16.34	16.95	19.67	≤ 20.47	Pass
11n-HT40	MCS0	134	5670	16.31	16.82	19.58	≤ 20.47	Pass
11n-HT40	MCS0	142	5710	16.34	16.83	19.60	≤ 20.47	Pass
11ac-VHT20	MCS0	52	5260	14.96	15.86	18.44	≤ 20.47	Pass
11ac-VHT20	MCS0	60	5300	15.33	16.02	18.70	≤ 20.47	Pass
11ac-VHT20	MCS0	64	5320	15.12	15.89	18.53	≤ 20.47	Pass
11ac-VHT20	MCS0	100	5500	14.43	15.15	17.82	≤ 20.47	Pass
11ac-VHT20	MCS0	120	5600	14.53	15.25	17.92	≤ 20.47	Pass
11ac-VHT20	MCS0	140	5700	14.43	15.16	17.82	≤ 20.47	Pass
11ac-VHT20	MCS0	144	5720	14.21	14.85	17.55	≤ 20.47	Pass
11ac-VHT40	MCS0	54	5270	16.29	16.91	19.62	≤ 20.47	Pass
11ac-VHT40	MCS0	62	5310	16.13	16.53	19.34	≤ 20.47	Pass
11ac-VHT40	MCS0	102	5510	16.08	16.91	19.53	≤ 20.47	Pass
11ac-VHT40	MCS0	118	5590	16.32	16.96	19.66	≤ 20.47	Pass
11ac-VHT40	MCS0	134	5670	16.33	16.85	19.61	≤ 20.47	Pass
11ac-VHT40	MCS0	142	5710	16.33	16.79	19.58	≤ 20.47	Pass
11ac-VHT80	MCS0	58	5290	16.54	16.86	19.71	≤ 20.47	Pass
11ac-VHT80	MCS0	106	5530	15.89	16.65	19.30	≤ 20.47	Pass
11ac-VHT80	MCS0	122	5610	15.96	16.51	19.25	≤ 20.47	Pass
11ac-VHT80	MCS0	138	5690	16.11	16.55	19.35	≤ 20.47	Pass

Note: The Total Average Power (dBm) = $10 \cdot \log\{10^{(\text{Ant 1 Average Power} / 10)} + 10^{(\text{Ant 2 Average Power} / 10)}\}$.

7.5. Transmit Power Control

7.5.1. Test Limit

The U-NII device is required to have the capability to operate at least 6 dB below the mean EIRP value of 30 dBm.

7.5.2. Test Procedure Used

KDB 789033 D02v01- Section E)3)b) Method PM-G

7.5.3. Test Setting

Average power measurements were performed only when the EUT was transmitting at its maximum power control level using a broadband power meter with a pulse sensor. The power meter implemented triggering and gating capabilities which were set up such that power measurements were recorded only during the ON time of the transmitter. The trace was averaged over 100 traces to obtain the final measured average power.

7.5.4. Test Setup

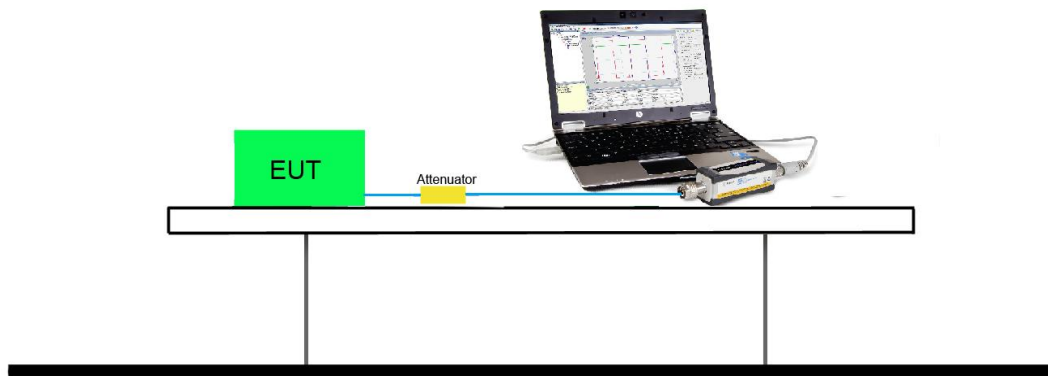

7.5.5. Test Result

Product	AC220 Wi-Fi AP OD directional antenna US	Temperature	22°C
Test Engineer	Hunk Li	Relative Humidity	54%
Test Site	TR3	Test Date	2017/08/27
Test Item	Transmit Power Control		

Test Mode	Data Rate /MCS	Channel No.	Freq. (MHz)	TPC Power (dBm)	EIRP TPC Power (dBm)	Limit (dBm)	Result
Ant 1							
11a	6Mbps	52	5260	11.63	22.63	≤ 24.00	Pass
11a	6Mbps	60	5300	11.45	22.45	≤ 24.00	Pass
11a	6Mbps	64	5320	11.37	22.37	≤ 24.00	Pass
11a	6Mbps	100	5500	11.20	21.70	≤ 24.00	Pass
11a	6Mbps	120	5600	11.31	21.81	≤ 24.00	Pass
11a	6Mbps	140	5700	11.41	21.91	≤ 24.00	Pass
11a	6Mbps	144	5720	11.28	21.78	≤ 24.00	Pass
11n-HT20	MCS0	52	5260	11.26	22.26	≤ 24.00	Pass
11n-HT20	MCS0	60	5300	11.54	22.54	≤ 24.00	Pass
11n-HT20	MCS0	64	5320	11.47	22.47	≤ 24.00	Pass
11n-HT20	MCS0	100	5500	11.31	21.81	≤ 24.00	Pass
11n-HT20	MCS0	120	5600	11.43	21.93	≤ 24.00	Pass
11n-HT20	MCS0	140	5700	11.48	21.98	≤ 24.00	Pass
11n-HT20	MCS0	144	5720	11.37	21.87	≤ 24.00	Pass
11n-HT40	MCS0	54	5270	11.68	22.68	≤ 24.00	Pass
11n-HT40	MCS0	62	5310	11.51	22.51	≤ 24.00	Pass
11n-HT40	MCS0	102	5510	11.25	21.75	≤ 24.00	Pass
11n-HT40	MCS0	110	5590	11.47	21.97	≤ 24.00	Pass
11n-HT40	MCS0	134	5670	11.42	21.92	≤ 24.00	Pass
11n-HT40	MCS0	142	5710	11.46	21.96	≤ 24.00	Pass
11ac-VHT20	MCS0	52	5260	11.30	22.30	≤ 24.00	Pass
11ac-VHT20	MCS0	60	5300	11.55	22.55	≤ 24.00	Pass
11ac-VHT20	MCS0	64	5320	11.44	22.44	≤ 24.00	Pass
11ac-VHT20	MCS0	100	5500	11.31	21.81	≤ 24.00	Pass
11ac-VHT20	MCS0	120	5600	11.40	21.90	≤ 24.00	Pass
11ac-VHT20	MCS0	140	5700	11.51	22.01	≤ 24.00	Pass
11ac-VHT20	MCS0	144	5720	11.36	21.86	≤ 24.00	Pass

Test Mode	Data Rate /MCS	Channel No.	Freq. (MHz)	TPC Power (dBm)	EIRP TPC Power (dBm)	Limit (dBm)	Result
Ant 1							
11ac-VHT40	MCS0	54	5270	11.67	22.67	≤ 24.00	Pass
11ac-VHT40	MCS0	62	5310	11.52	22.52	≤ 24.00	Pass
11ac-VHT40	MCS0	102	5510	11.25	21.75	≤ 24.00	Pass
11ac-VHT40	MCS0	110	5590	11.47	21.97	≤ 24.00	Pass
11ac-VHT40	MCS0	134	5670	11.39	21.89	≤ 24.00	Pass
11ac-VHT40	MCS0	142	5710	11.44	21.94	≤ 24.00	Pass
11ac-VHT80	MCS0	58	5290	11.23	22.23	≤ 24.00	Pass
11ac-VHT80	MCS0	106	5530	11.39	21.89	≤ 24.00	Pass
11ac-VHT80	MCS0	122	5610	11.57	22.07	≤ 24.00	Pass
11ac-VHT80	MCS0	138	5690	11.62	22.12	≤ 24.00	Pass

Note: EIRP TPC Power (dBm) = TPC Power (dBm) + Antenna Gain (dBi).



Test Mode	Data Rate /MCS	Channel No.	Freq. (MHz)	TPC Power (dBm)	EIRP TPC Power (dBm)	Limit (dBm)	Result
Ant 2							
11a	6Mbps	52	5260	11.52	22.52	≤ 24.00	Pass
11a	6Mbps	60	5300	11.61	22.61	≤ 24.00	Pass
11a	6Mbps	64	5320	11.51	22.51	≤ 24.00	Pass
11a	6Mbps	100	5500	11.45	21.95	≤ 24.00	Pass
11a	6Mbps	120	5600	11.52	22.02	≤ 24.00	Pass
11a	6Mbps	140	5700	11.36	21.86	≤ 24.00	Pass
11a	6Mbps	144	5720	11.15	21.65	≤ 24.00	Pass
11n-HT20	MCS0	52	5260	11.31	22.31	≤ 24.00	Pass
11n-HT20	MCS0	60	5300	11.71	22.71	≤ 24.00	Pass
11n-HT20	MCS0	64	5320	11.62	22.62	≤ 24.00	Pass
11n-HT20	MCS0	100	5500	11.53	22.03	≤ 24.00	Pass
11n-HT20	MCS0	120	5600	11.63	22.13	≤ 24.00	Pass
11n-HT20	MCS0	140	5700	11.47	21.97	≤ 24.00	Pass
11n-HT20	MCS0	144	5720	11.22	21.72	≤ 24.00	Pass
11n-HT40	MCS0	54	5270	11.24	22.24	≤ 24.00	Pass
11n-HT40	MCS0	62	5310	11.67	22.67	≤ 24.00	Pass
11n-HT40	MCS0	102	5510	11.51	22.01	≤ 24.00	Pass
11n-HT40	MCS0	110	5590	11.35	21.85	≤ 24.00	Pass
11n-HT40	MCS0	134	5670	11.52	22.02	≤ 24.00	Pass
11n-HT40	MCS0	142	5710	11.41	21.91	≤ 24.00	Pass
11ac-VHT20	MCS0	52	5260	11.31	22.31	≤ 24.00	Pass
11ac-VHT20	MCS0	60	5300	11.71	22.71	≤ 24.00	Pass
11ac-VHT20	MCS0	64	5320	11.61	22.61	≤ 24.00	Pass
11ac-VHT20	MCS0	100	5500	11.53	22.03	≤ 24.00	Pass
11ac-VHT20	MCS0	120	5600	11.62	22.12	≤ 24.00	Pass
11ac-VHT20	MCS0	140	5700	11.46	21.96	≤ 24.00	Pass
11ac-VHT20	MCS0	144	5720	11.26	21.76	≤ 24.00	Pass

Test Mode	Data Rate /MCS	Channel No.	Freq. (MHz)	TPC Power (dBm)	EIRP TPC Power (dBm)	Limit (dBm)	Result
Ant 2							
11ac-VHT40	MCS0	54	5270	11.25	22.25	≤ 24.00	Pass
11ac-VHT40	MCS0	62	5310	11.65	22.65	≤ 24.00	Pass
11ac-VHT40	MCS0	102	5510	11.52	22.02	≤ 24.00	Pass
11ac-VHT40	MCS0	110	5590	11.34	21.84	≤ 24.00	Pass
11ac-VHT40	MCS0	134	5670	11.54	22.04	≤ 24.00	Pass
11ac-VHT40	MCS0	142	5710	11.42	21.92	≤ 24.00	Pass
11ac-VHT80	MCS0	58	5290	11.35	22.35	≤ 24.00	Pass
11ac-VHT80	MCS0	106	5530	11.31	21.81	≤ 24.00	Pass
11ac-VHT80	MCS0	122	5610	11.21	21.71	≤ 24.00	Pass
11ac-VHT80	MCS0	138	5690	11.29	21.79	≤ 24.00	Pass

Note: EIRP TPC Power (dBm) = TPC Power (dBm) + Antenna Gain (dBi).



Test Mode	Data Rate /MCS	Channel No.	Freq. (MHz)	Ant 1 TPC Power (dBm)	Ant 2 TPC Power (dBm)	Total EIRP TPC Power (dBm)	Limit (dBm)	Result
Ant 1 + 2 (CDD Mode)								
11a	6Mbps	52	5260	8.42	8.84	22.65	≤ 24.00	Pass
11a	6Mbps	60	5300	8.28	8.72	22.52	≤ 24.00	Pass
11a	6Mbps	64	5320	7.95	8.63	22.31	≤ 24.00	Pass
11a	6Mbps	100	5500	8.06	9.24	22.20	≤ 24.00	Pass
11a	6Mbps	118	5580	8.13	8.96	22.08	≤ 24.00	Pass
11a	6Mbps	120	5600	8.25	8.73	22.01	≤ 24.00	Pass
11a	6Mbps	140	5700	8.31	8.75	22.05	≤ 24.00	Pass
11a	6Mbps	144	5720	8.24	8.60	21.93	≤ 24.00	Pass
11n-HT20	MCS0	52	5260	8.07	8.57	22.34	≤ 24.00	Pass
11n-HT20	MCS0	60	5300	8.40	8.85	22.64	≤ 24.00	Pass
11n-HT20	MCS0	64	5320	8.17	8.77	22.49	≤ 24.00	Pass
11n-HT20	MCS0	100	5500	7.70	8.71	21.74	≤ 24.00	Pass
11n-HT20	MCS0	118	5580	7.72	8.50	21.64	≤ 24.00	Pass
11n-HT20	MCS0	120	5600	7.83	8.48	21.68	≤ 24.00	Pass
11n-HT20	MCS0	140	5700	8.44	8.93	22.20	≤ 24.00	Pass
11n-HT20	MCS0	144	5720	8.31	8.75	22.05	≤ 24.00	Pass
11n-HT40	MCS0	54	5270	8.50	8.90	22.71	≤ 24.00	Pass
11n-HT40	MCS0	62	5310	8.33	8.76	22.56	≤ 24.00	Pass
11n-HT40	MCS0	102	5510	7.65	8.48	21.60	≤ 24.00	Pass
11n-HT40	MCS0	110	5550	7.78	8.34	21.58	≤ 24.00	Pass
11n-HT40	MCS0	118	5590	7.81	8.23	21.54	≤ 24.00	Pass
11n-HT40	MCS0	134	5670	8.41	8.63	22.03	≤ 24.00	Pass
11n-HT40	MCS0	142	5710	8.31	8.82	22.08	≤ 24.00	Pass
11ac-VHT20	MCS0	52	5260	8.52	8.84	22.69	≤ 24.00	Pass
11ac-VHT20	MCS0	60	5300	8.22	8.42	22.33	≤ 24.00	Pass
11ac-VHT20	MCS0	64	5320	8.08	8.72	22.42	≤ 24.00	Pass
11ac-VHT20	MCS0	100	5500	7.73	8.68	21.74	≤ 24.00	Pass
11ac-VHT20	MCS0	116	5580	7.81	8.41	21.63	≤ 24.00	Pass
11ac-VHT20	MCS0	120	5600	7.83	8.36	21.61	≤ 24.00	Pass
11ac-VHT20	MCS0	140	5700	8.42	8.48	21.96	≤ 24.00	Pass
11ac-VHT20	MCS0	144	5720	8.21	8.31	21.77	≤ 24.00	Pass



Test Mode	Data Rate /MCS	Channel No.	Freq. (MHz)	Ant 1 TPC Power (dBm)	Ant 2 TPC Power (dBm)	Total EIRP TPC Power (dBm)	Limit (dBm)	Result
Ant 1 + 2 (CDD Mode)								
11ac-VHT40	MCS0	54	5270	8.47	8.75	22.62	≤ 24.00	Pass
11ac-VHT40	MCS0	62	5310	8.28	8.68	22.49	≤ 24.00	Pass
11ac-VHT40	MCS0	102	5510	7.68	8.49	21.61	≤ 24.00	Pass
11ac-VHT40	MCS0	110	5550	7.77	8.42	21.62	≤ 24.00	Pass
11ac-VHT40	MCS0	118	5590	7.89	8.25	21.58	≤ 24.00	Pass
11ac-VHT40	MCS0	134	5670	8.22	8.75	22.00	≤ 24.00	Pass
11ac-VHT40	MCS0	142	5710	8.31	8.71	22.02	≤ 24.00	Pass
11ac-VHT80	MCS0	58	5290	8.05	8.46	22.27	≤ 24.00	Pass
11ac-VHT80	MCS0	106	5530	7.64	8.73	21.73	≤ 24.00	Pass
11ac-VHT80	MCS0	122	5610	8.07	8.43	21.76	≤ 24.00	Pass
11ac-VHT80	MCS0	138	5690	8.10	8.54	21.84	≤ 24.00	Pass

Note: Total EIRP TPC Power (dBm) = $10 \cdot \log \{ 10^{((\text{Ant 1 TPC Power} + \text{Ant 1 Gain} / 10))} + 10^{((\text{Ant 2 TPC Power} + \text{Ant 2 Gain} / 10))} \}$.

7.6. Power Spectral Density Measurement

7.6.1. Test Limit

For the 5.25-5.35 GHz and 5.47-5.725 GHz bands, the maximum power spectral density shall not exceed 11 dBm in any 1 megahertz band.

If transmitting antennas of directional gain greater than 6dBi are used, the peak power spectral density shall be reduced by the amount in dB that the directional gain of the antenna exceeds 6dBi.

Output Power Measurement limit of AC220 Wi-Fi AP OD directional antenna US

Frequency Band (MHz)	Per Chain Max Antenna Gain (dBi)		CDD & Beam Forming Directional Gain (dBi)	Limit of SISO (dBm)		Limit of MIMO (dBm/MHz)
	Ant 1	Ant 2		Ant 1	Ant 2	
5250 ~ 5350	11.00	11.00	14.01	6.00	6.00	2.99
5470 ~ 5725	10.50	10.50	13.51	6.50	6.50	3.49

Output Power Measurement limit of AC220 Wi-Fi AP OD external antenna US

Frequency Band (MHz)	Per Chain Max Antenna Gain (dBi)		CDD & Beam Forming Directional Gain (dBi)	Limit of SISO (dBm)		Limit of MIMO (dBm/MHz)
	Ant 1	Ant 2		Ant 1	Ant 2	
5250 ~ 5350	5.00	5.00	8.01	11.00	11.00	8.99
5470 ~ 5725	5.00	5.00	8.01	11.00	11.00	8.99

Output Power Measurement limit of AC220 Wi-Fi AP OD small omni antenna US

Frequency Band (MHz)	Per Chain Max Antenna Gain (dBi)		CDD & Beam Forming Directional Gain (dBi)	Limit of SISO (dBm)		Limit of MIMO (dBm/MHz)
	Ant 1	Ant 2		Ant 1	Ant 2	
5250 ~ 5350	6.50	6.50	9.51	10.50	10.50	7.49
5470 ~ 5725	6.50	6.50	9.51	10.50	10.50	7.49

7.6.2. Test Procedure Used

ANSI C63.10-2013 - Section F

7.6.3. Test Setting

1. Analyzer was set to the center frequency of the UNII channel under investigation
2. Span was set to encompass the entire 26dB EBW of the signal.
3. RBW = 1MHz, if measurement bandwidth of Maximum PSD is specified in 500 kHz,
RBW = 100 kHz
4. VBW = 3MHz
5. Number of sweep points $\geq 2 \times (\text{span} / \text{RBW})$
6. Detector = power averaging (Average)
7. Sweep time = auto
8. Trigger = free run
9. Use the peak search function on the instrument to find the peak of the spectrum and record its value.
10. Add $10 \cdot \log(1/x)$, where x is the duty cycle, to the measured power in order to compute the average power during the actual transmission times (because the measurement represents an average over both the on and off times of the transmission). For example, add $10 \cdot \log(1/0.25) = 6$ dB if the duty cycle is 25 percent.
11. When the measurement bandwidth of Maximum PSD is specified in 500 kHz, add a constant factor $10 \cdot \log(500\text{kHz}/100\text{kHz}) = 6.99$ dB to the measured result.

7.6.4. Test Setup

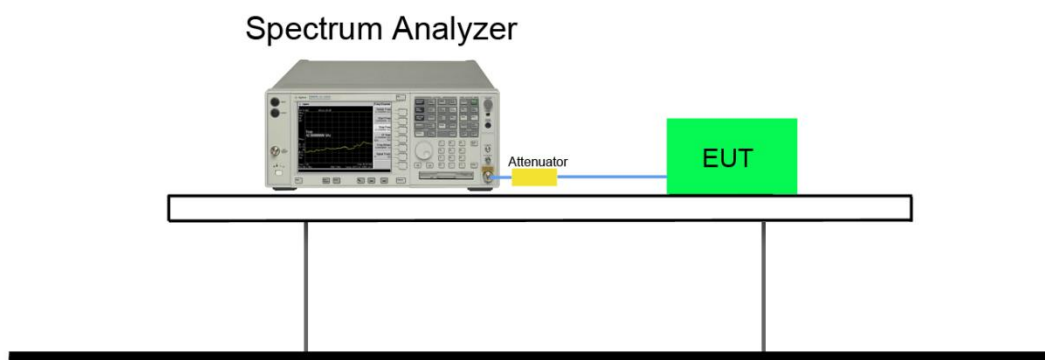

7.6.5. Test Result

Refer to “Annex I Power Spectral Density Test Result” File.

7.7. Frequency Stability Measurement

7.7.1. Test Limit

Manufactures of U-NII devices are responsible for ensuring frequency stability such that an emission is maintained within the band of operation under all conditions of normal operation as specified in the user's manual.

The transmitter center frequency tolerance shall be ± 20 ppm maximum for the 5GHz band (IEEE 802.11 specification).

7.7.2. Test Procedure Used

Frequency Stability Under Temperature Variations:

The equipment under test was connected to an external AC or DC power supply and input rated voltage. RF output was connected to a frequency counter or spectrum analyzer via feed through attenuators. The EUT was placed inside the temperature chamber. Set the spectrum analyzer RBW low enough to obtain the desired frequency resolution and measure EUT 20°C operating frequency as reference frequency. Turn EUT off and set the chamber temperature to highest. After the temperature stabilized for approximately 30 minutes recorded the frequency. Repeat step measure with 10°C decreased per stage until the lowest temperature reached.

Frequency Stability Under Voltage Variations:

Set chamber temperature to 20°C. Use a variable AC power supply / DC power source to power the EUT and set the voltage to rated voltage. Set the spectrum analyzer RBW low enough to obtain the desired frequency resolution and recorded the frequency.

Reduce the input voltage to specify extreme voltage variation ($\pm 15\%$) and endpoint, record the maximum frequency change.

7.7.3. Test Setup

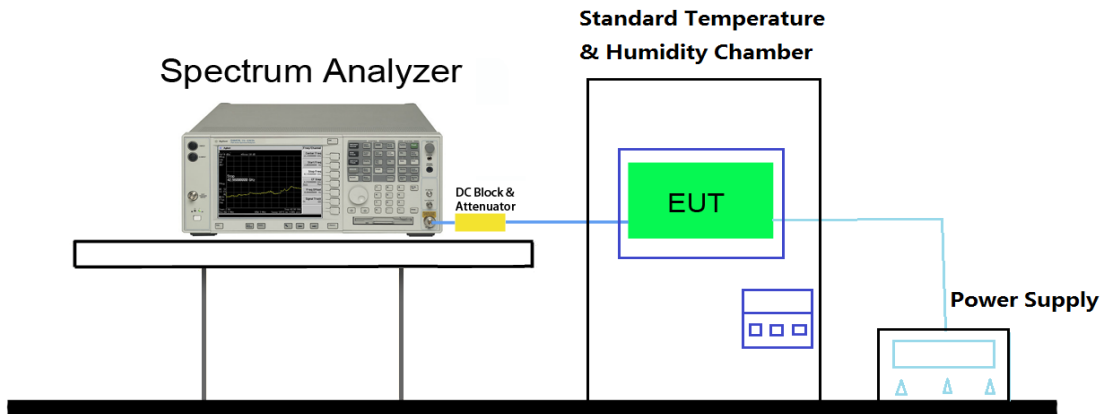

7.7.4. Test Result

Refer to MRT Test report “1707TW0110-U2” section 7.7.4

7.8. Radiated Spurious Emission Measurement

7.8.1. Test Limit

All out of band emissions appearing in a restricted band as specified in Section 8.10 of the RSS-Gen Issue 4 must not exceed the limits shown in Table per Section 8.9.

RSS-Gen Issue4 Section 8.9		
Frequency [MHz]	Field Strength [V/m]	Measured Distance [Meters]
0.009 - 0.490	2400/F (kHz)	300
0.490 - 1.705	24000/F (kHz)	30
1.705 - 30	30	30
30 - 88	100	3
88 - 216	150	3
216 - 960	200	3
Above 960	500	3

7.8.2. Test Procedure Used

ANSI C63.10 Section 6.3 (General Requirements)

ANSI C63.10 Section 6.4 (Standard test method below 30MHz)

ANSI C63.10 Section 6.5 (Standard test method above 30MHz to 1GHz)

ANSI C63.10 Section 6.6 (Standard test method above 1GHz)

7.8.3. Test Setting

Quasi-Peak & Average Measurements below 30MHz

1. Analyzer center frequency was set to the frequency of the radiated spurious emission of interest
2. Span was set greater than 1MHz
3. RBW = 200Hz for 9kHz to 150kHz frequency; RBW = 9kHz for 0.15MHz to 30MHz frequency
4. Detector = CISPR quasi-peak or power average (Average)
5. Sweep time = auto couple
6. Trace was allowed to stabilize

Quasi-Peak Measurements below 1GHz

1. Analyzer center frequency was set to the frequency of the radiated spurious emission of interest
2. Span was set greater than 1MHz
3. RBW = 120 kHz
4. Detector = CISPR quasi-peak
5. Sweep time = auto couple
6. Trace was allowed to stabilize

Peak Measurements above 1GHz

1. Analyzer center frequency was set to the frequency of the radiated spurious emission of interest
2. RBW = 1MHz
3. VBW = 3MHz
4. Detector = peak
5. Sweep time = auto couple
6. Trace mode = max hold
7. Trace was allowed to stabilize

Average Measurements above 1GHz (Method AD)

1. Analyzer center frequency was set to the frequency of the radiated spurious emission of interest
2. RBW = 1MHz
3. VBW = 3MHz
4. Detector = power average (Average)
5. Number of measurement points = 1001 (Number of points must be $> 2 \times \text{span/RBW}$)
6. Sweep time = auto
7. Trace was averaged over at 100 sweeps

7.8.4. Test Setup

9kHz ~30MHz Test Setup:

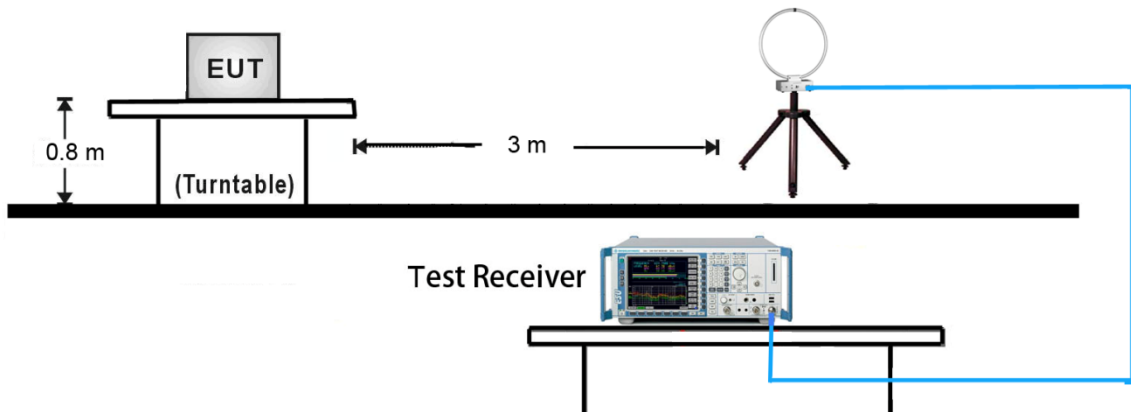

30MHz ~ 1GHz Test Setup:

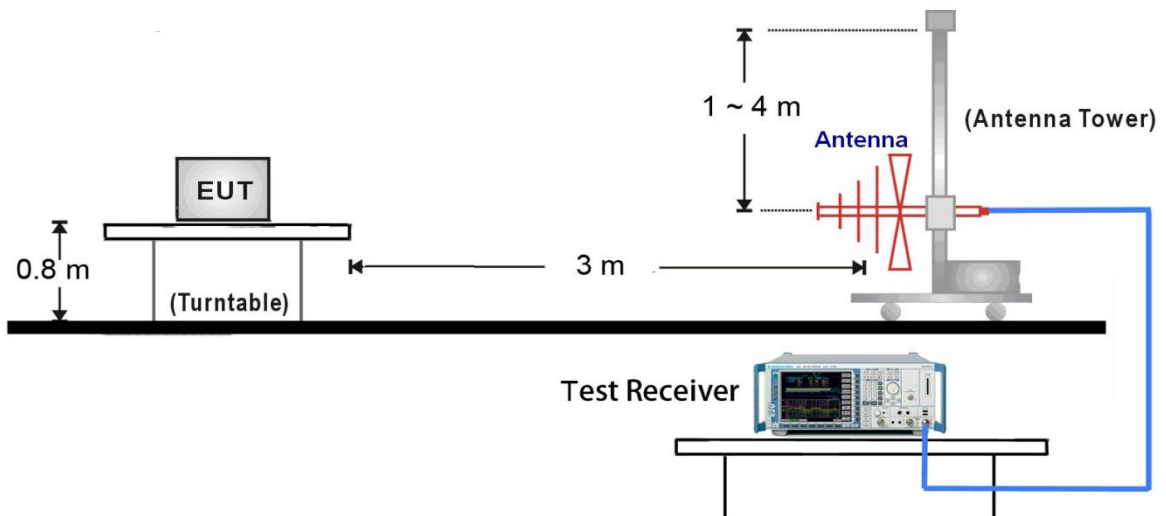

1GHz ~18GHz Test Setup:

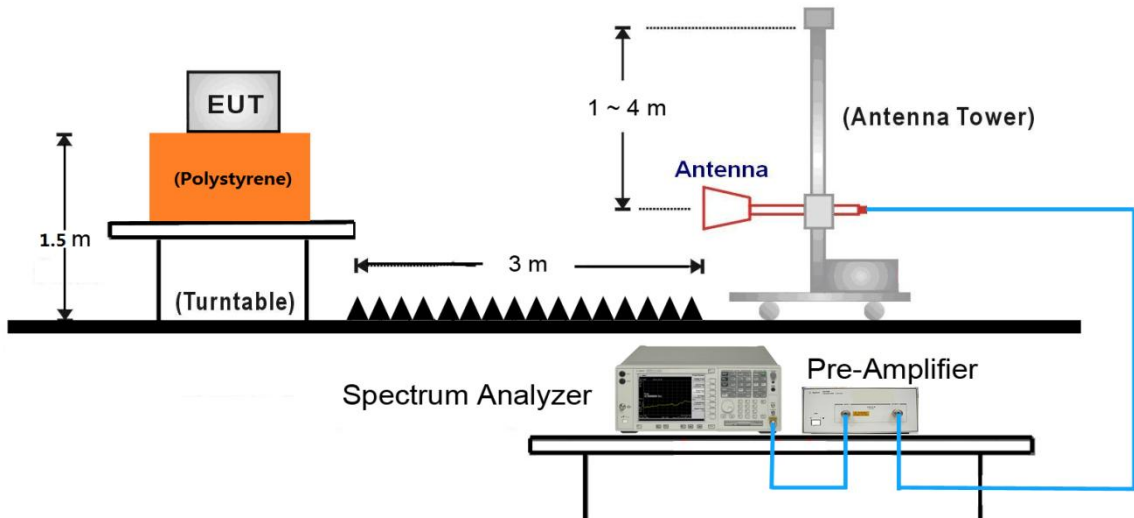

18GHz ~40GHz Test Setup:

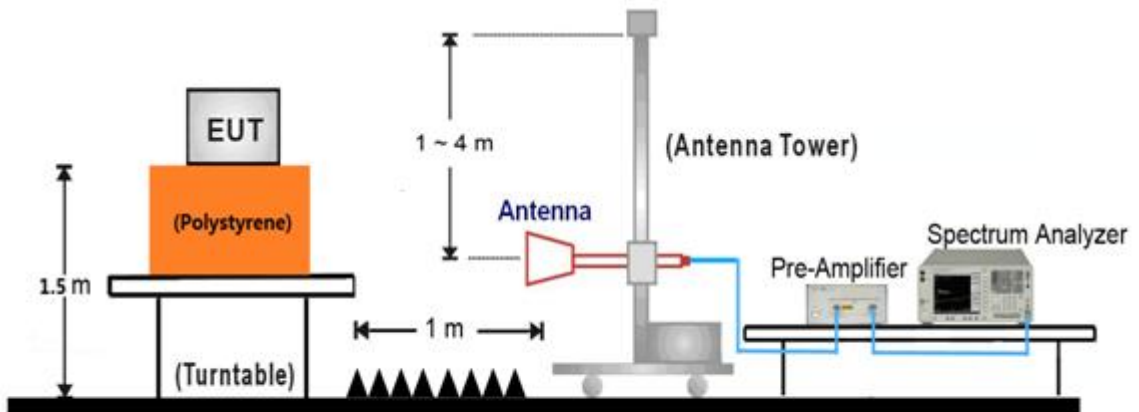

7.8.5. Test Result

Refer to “Annex II Radiated Spurious Emission Test Result” File.

The worst case of Radiated Emission below 1GHz:

Site: AC1	Time: 2017/08/23 - 14:13
Limit: FCC Part15.209_RE(3m)	Engineer: Kevin Ker
Probe: VULB 9168_20-2000MHz	Polarity: Horizontal
EUT: AC220 Wi-Fi AP OD external antenna US	Power: DC 54V
Note: There is the worst case within frequency range 30MHz~1GHz.	

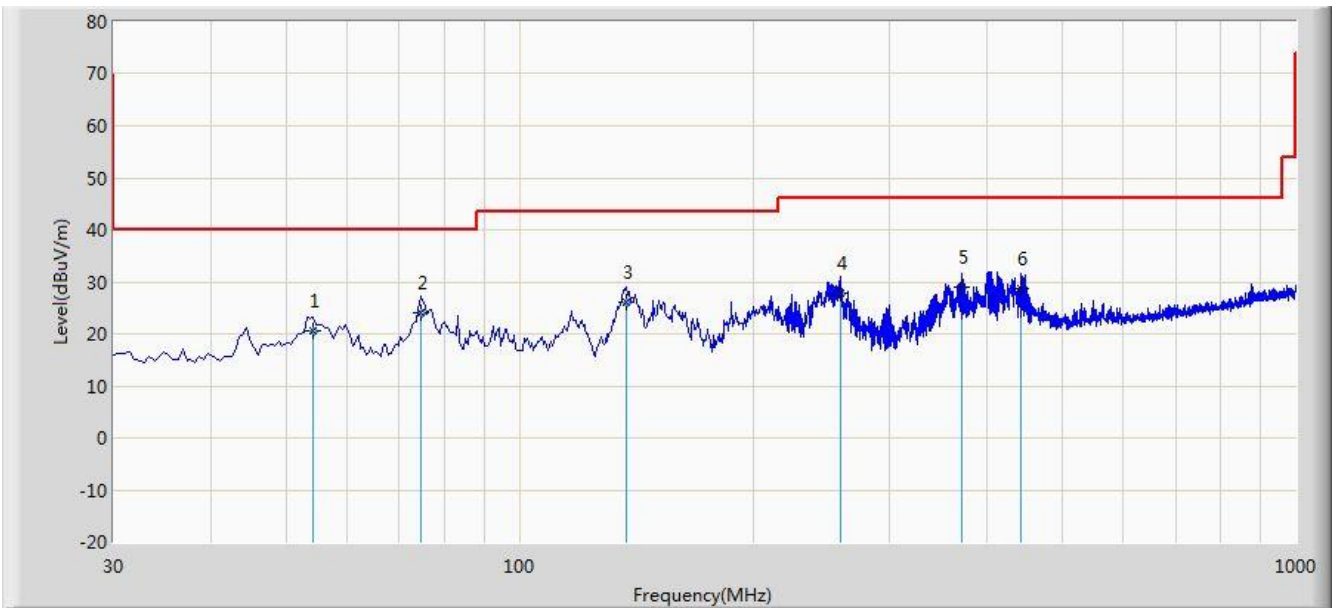

No	Flag	Mark	Frequency (MHz)	Measure Level (dBuV/m)	Reading Level (dBuV)	Margin (dB)	Limit (dBuV/m)	Factor (dB)	Type
1			54.250	20.691	5.846	-19.309	40.000	14.845	QP
2		*	74.620	24.072	14.195	-15.928	40.000	9.877	QP
3			137.185	26.200	16.473	-17.300	43.500	9.727	QP
4			259.405	27.781	13.734	-18.219	46.000	14.047	QP
5			370.995	28.885	12.518	-17.115	46.000	16.367	QP
6			442.250	28.732	11.205	-17.268	46.000	17.527	QP

Note 1: Measure Level (dBuV/m) = Reading Level (dBuV) + Factor (dB)

Factor (dB) = Cable Loss (dB) + Antenna Factor (dB/m)

Note 2: The test trace is same as the ambient noise and the amplitude of the emissions are attenuated more than 20dB below the permissible (the test frequency range: 9kHz ~ 30MHz, 18GHz ~ 40GHz), therefore no data appear in the report.

Site: AC1	Time: 2017/08/23 - 14:25
Limit: FCC Part15.209_RE(3m)	Engineer: Kevin Ker
Probe: VULB 9168_20-2000MHz	Polarity: Vertical
EUT: AC220 Wi-Fi AP OD external antenna US	Power: DC 54V
Note: There is the worst case within frequency range 30MHz~1GHz.	

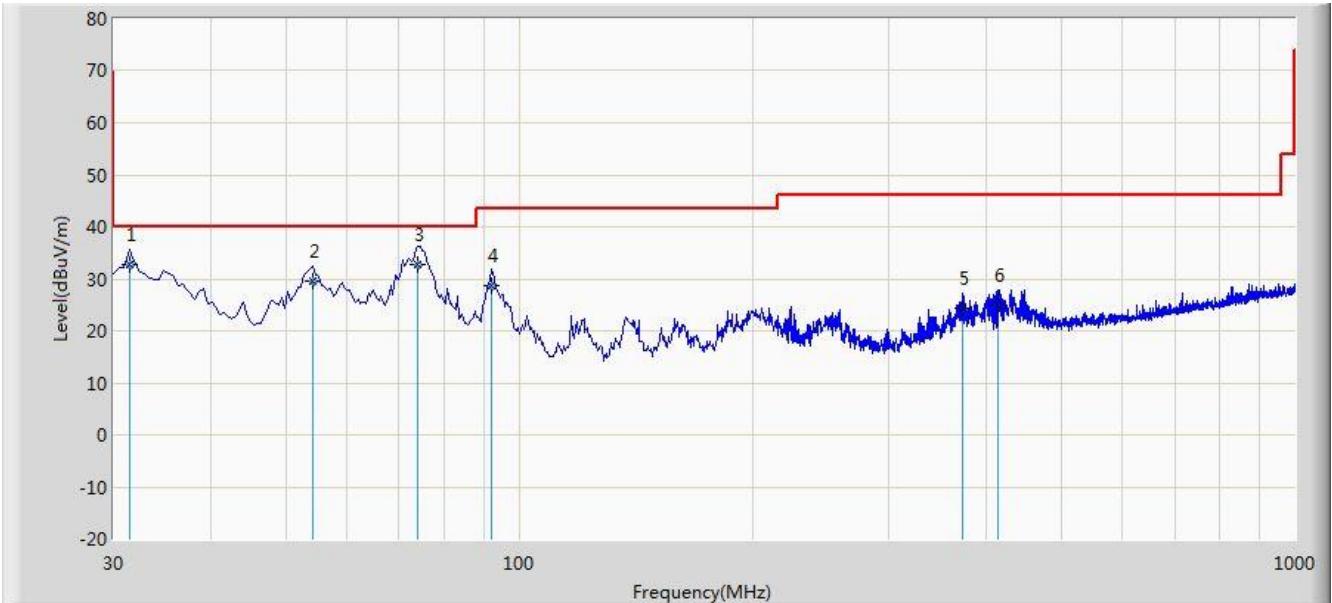

No	Flag	Mark	Frequency (MHz)	Measure Level (dBuV/m)	Reading Level (dBuV)	Margin (dB)	Limit (dBuV/m)	Factor (dB)	Type
1			31.455	32.710	20.405	-7.290	40.000	12.305	QP
2			54.250	29.517	14.672	-10.483	40.000	14.845	QP
3		*	74.135	32.853	22.864	-7.147	40.000	9.989	QP
4			92.080	28.660	16.834	-14.840	43.500	11.826	QP
5			372.410	24.355	7.967	-21.645	46.000	16.387	QP
6			414.120	24.980	7.824	-21.020	46.000	17.155	QP

Note 1: Measure Level (dBuV/m) = Reading Level (dBuV) + Factor (dB)

Factor (dB) = Cable Loss (dB) + Antenna Factor (dB/m)

Note 2: The test trace is same as the ambient noise and the amplitude of the emissions are attenuated more than 20dB below the permissible (the test frequency range: 9kHz ~ 30MHz, 18GHz ~ 40GHz), therefore no data appear in the report.

7.9. Radiated RestrictedBand Edge Measurement

7.9.1. Test Limit

For 15.205 requirement:

Radiated emissions which fall in the restricted bands, as defined in Section 15.205(a) of FCC part 15, must also comply with the radiated emission limits specified in Section 15.209(a).

Frequency (MHz)	Frequency (MHz)	Frequency (MHz)	Frequency (GHz)
0.090 - 0.110	16.42-16.423	399.9 - 410	4.5-5.15
¹ 0.495 - 0.505	16.69475-16.69525	608 - 614	5.35-5.46
2.1735-2.1905	16.80425-16.80475	960 - 1240	7.25-7.75
4.125-4.128	25.5 -25.67	1300 - 1427	8.25 - 8.5
4.17725-4.17775	37.5-38.25	1435-1626.5	9.0-9.2
4.20725-4.20775	73-74.6	1645.5-1646.5	9.3-9.5
6.215-6.218	74.8-75.2	1660 - 1710	10.6-12.7
6.26775-6.26825	108-121.94	1718.8-1722.2	13.25-13.4
6.31175-6.31225	123 - 138	2200 - 2300	14.47-14.5
8.291-8.294	149.9-150.05	2310-2390	15.35-16.2
8.362-8.366	156.52475-156.525	2483.5 - 2500	17.7-21.4
8.37625-8.38675	156.7-156.9	2690 - 2900	22.01-23.12
8.41425-8.41475	162.0125-167.17	3260 - 3267	23.6-24.0
12.29-12.293	167.72-173.2	3332 - 3339	31.2-31.8
12.51975-12.52025	240 - 285	3345.8 - 3358	36.43-36.5
12.57675-12.57725	322-335.4	3600 - 4400	(²)
13.36-13.41	--	--	--

For 15.407(b) requirement:

For transmitters operating in the 5.15-5.25 GHz band: All emissions outside of the 5.15-5.35 GHz band shall not exceed an e.i.r.p. of -27 dBm/MHz.

For transmitters operating in the 5.725-5.85 GHz band: All emissions within the frequency range from the band edge to 10 MHz above or below the band edge shall not exceed an e.i.r.p. of -17 dBm/MHz; for frequencies 10 MHz or greater above or below the band edge, emissions shall not exceed an e.i.r.p. of -27 dBm/MHz.

Refer to KDB 789033 D02v01r04 G)2)c), as specified in § 15.407(b), emissions above 1000 MHz

that are outside of the restricted bands are subject to a maximum emission limit of -27 dBm/MHz (or -17 dBm/MHz as specified in § 15.407(b)(4)). However, an out-of-band emission that complies with both the peak and average limits of § 15.209 is not required to satisfy the -27 dBm/MHz or -17 dBm/MHz maximum emission limit.

All out of band emissions appearing in a restricted band as specified in Section 15.205 of the Title 47CFR must not exceed the limits shown in Table per Section 15.209.

FCC Part 15 Subpart C Paragraph 15.209		
Frequency [MHz]	Field Strength [uV/m]	Measured Distance [Meters]
0.009 – 0.490	2400/F (kHz)	300
0.490 – 1.705	24000/F (kHz)	30
1.705 - 30	30	30
30 - 88	100	3
88 - 216	150	3
216 - 960	200	3
Above 960	500	3

For RSS-Gen Section 8.10 Requirement:

Radiated emissions which fall in the restricted bands, as defined in Section 8.10 of RSS-Gen, must also comply with the radiated emission limits specified in Section 8.9.

Frequency (MHz)	Frequency (MHz)	Frequency (GHz)
0.009 ~ 0.110	240 ~ 285	9.0 ~ 9.2
2.1735 ~ 2.1905	322 ~ 335.4	9.3 ~ 9.5
3.020 ~ 3.026	399.9 ~ 410	10.6 ~ 12.7
4.125 ~ 4.128	608 ~ 614	13.25 ~ 13.4
4.17725 ~ 4.17775	960 ~ 1427	14.47 ~ 14.5
4.20725 ~ 4.20775	1435 ~ 1626.5	15.35 ~ 16.2
5.677 ~ 5.683	1645.5 ~ 1646.5	17.7 ~ 21.4
6.215 ~ 6.218	1660 ~ 1710	22.01 ~ 23.12
6.26775 ~ 6.26825	1718.8 ~ 1722.2	23.6 ~ 24.0
6.31175 ~ 6.31225	2200 ~ 2300	31.2 ~ 31.8
8.291 ~ 8.294	2310 ~ 2390	36.43 ~ 36.5
8.362 ~ 8.366	2655 ~ 2900	Above 38.6
8.37625 ~ 8.38675	3260 ~ 3267	--

8.41425 ~ 8.41475	3332 ~ 3339	
12.29 ~ 12.293	334.5 ~ 3358	
12.51975 ~ 12.52025	3500 ~ 4400	
12.57675 ~ 12.57725	4500 ~ 5150	
13.36 ~ 13.41	5350 ~ 5460	
16.42 ~ 16.423	7250 ~ 7750	
16.69475 ~ 16.69525	8025 ~ 8500	
16.80425 ~ 16.80475	--	
25.5 ~ 25.67		
37.5 ~ 38.25		
73 ~ 74.6		
74.8 ~ 75.2		
108 ~ 138		
156.52475 ~ 156.525225		
156.7 ~ 156.9		

Note: *Certain frequency bands listed in Table 6 and in bands above 38.6 GHz are designated for licence-exempt applications. These frequency bands and the requirements that apply to the devices are set out in the 200- and 300-series of RSSs, such as RSS-210 and RSS-310, which contain the requirements that apply to licence-exempt radio apparatus.

For RSS-247 Section 6.2 Requirement:

For transmitters operating in the 5.15-5.25 GHz band: All emissions outside of the 5.15-5.25 GHz band shall not exceed an e.i.r.p. of -27 dBm/MHz.

For transmitters operating in the 5.25-5.35 GHz band: All emissions outside of the 5.25-5.35 GHz band shall not exceed an e.i.r.p. of -27 dBm/MHz.

For transmitters operating in the 5.47-5.725 GHz band: All emissions outside of the 5.47-5.725 GHz band shall not exceed an e.i.r.p. of -27 dBm/MHz.

Operating Frequency Band (MHz)	EIRP Limit (dBm/MHz)	Equivalent Field Strength at 3m (dBuV/m)
5150 - 5250	-27	68.2
5250 - 5350	-27	68.2
5470 - 5725	-27	68.2

Note: As specified in section 6.2 of RSS-247, emissions above 1000 MHz that are outside of the

restricted bands are subject to a maximum emission limit of -27dBm/MHz. However, an out-of-band emission that complies with both the peak and average limits of 8.9 in RSS-Gen is not required to satisfy the -27 dBm/MHz.

All out of band emissions appearing in a restricted band as specified in Section 8.10 of the RSS-Gen must not exceed the limits shown in Table per Section 8.9.

RSS-Gen Section 8.9		
Frequency [MHz]	Field Strength [V/m]	Measured Distance [Meters]
0.009 - 0.490	2400/F (kHz)	300
0.490 - 1.705	24000/F (kHz)	30
1.705 - 30	30	30
30 - 88	100	3
88 - 216	150	3
216 - 960	200	3
Above 960	500	3

7.9.2. Test Result

Refer to “Annex III Radiated Bandedge Test Result” File.

7.10. AC Conducted Emissions Measurement

7.10.1. Test Limit

FCC Part 15.207 Limits		
Frequency (MHz)	QP (dB μ V)	AV (dB μ V)
0.15 - 0.50	66 - 56	56 – 46
0.50 - 5.0	56	46
5.0 - 30	60	50

Note 1: The lower limit shall apply at the transition frequencies.

Note 2: The limit decreases linearly with the logarithm of the frequency in the range 0.15MHz to 0.5MHz.

7.10.2. Test Procedure

The EUT was setup according to ANSI C63.10, 2013 for compliance to RSS-Gen Issue 4 requirements. The EUT was placed on a platform of nominal size, 1 m by 1.5 m, raised 80 cm above the conducting ground plane. The vertical conducting plane was located 40 cm to the rear of the EUT. All other surfaces of EUT were at least 80 cm from any other grounded conducting surface. The EUT and simulators are connected to the main power through a line impedance stabilization network (LISN). The LISN provides a 50 ohm /50uH coupling impedance for the measuring equipment. The peripheral devices are also connected to the main power through a LISN. (Please refer to the block diagram of the test setup and photographs) Each current-carrying conductor of the EUT power cord, except the ground (safety) conductor, was individually connected through a LISN to the input power source.

The excess length of the power cord between the EUT and the LISN receptacle were folded back and forth at the center of the lead to form a bundle not exceeding 40 cm in length.

Conducted emissions were investigated over the frequency range from 0.15MHz to 30MHz using a receiver bandwidth of 9 kHz.

7.10.3. Test Setup

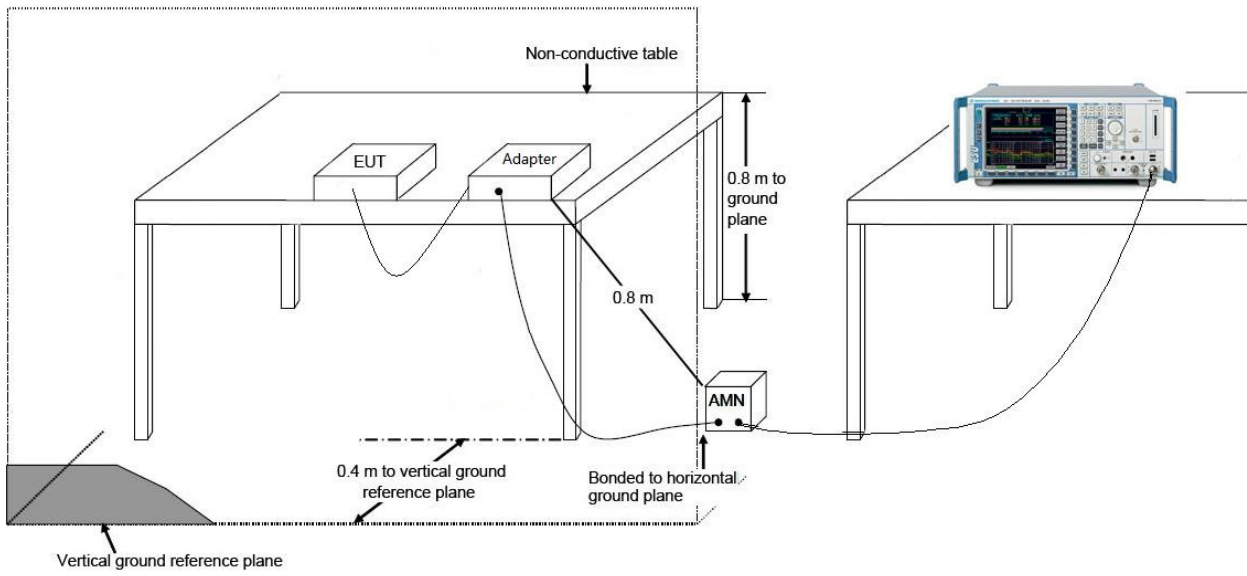

7.10.4. Test Result

Site: SR2	Time: 2017/08/02 - 18:52
Limit: FCC_Part 15.207_CE Main	Engineer: Kevin Ker
Probe: ENV216_101683_Filter On	Polarity: Line
EUT: AC220 Wi-Fi AP OD external antenna US	Power: AC 120V/60Hz
Test Mode: Mode 1	

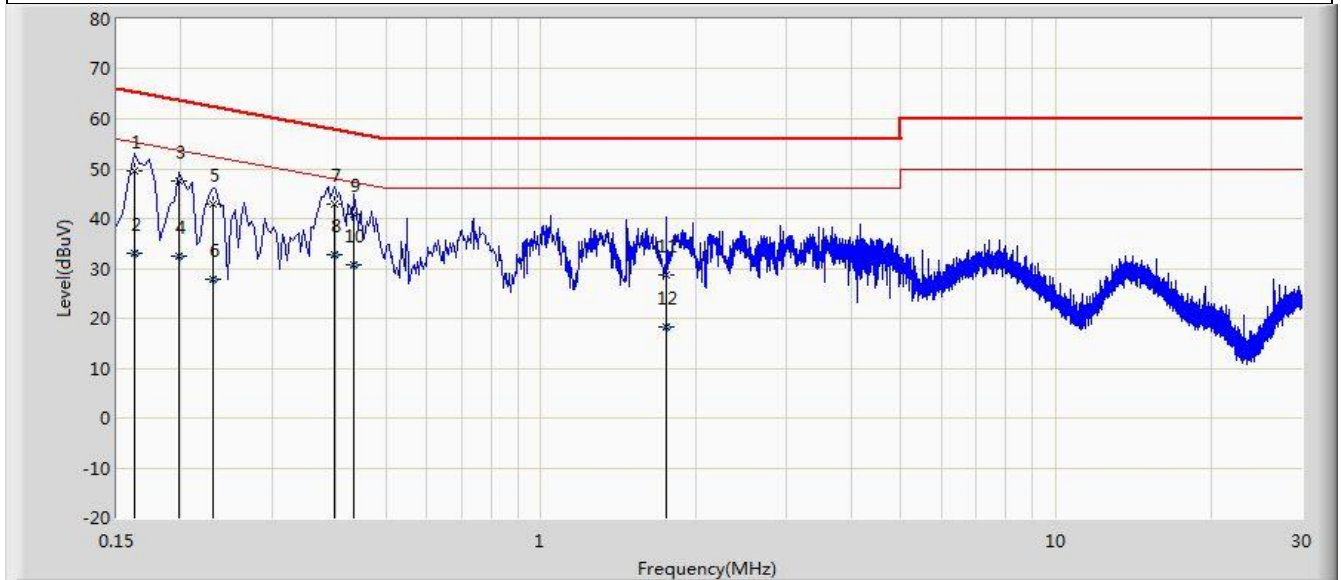

No	Flag	Mark	Frequency (MHz)	Measure Level (dBuV)	Reading Level (dBuV)	Margin (dB)	Limit (dBuV)	Factor (dB)	Type
1			0.162	49.561	39.464	-15.799	65.361	10.097	QP
2			0.162	33.181	23.084	-22.179	55.361	10.097	AV
3			0.198	47.536	37.531	-16.158	63.694	10.005	QP
4			0.198	32.474	22.470	-21.220	53.694	10.005	AV
5			0.230	42.949	33.002	-19.501	62.450	9.947	QP
6			0.230	27.810	17.863	-24.639	52.450	9.947	AV
7			0.398	42.871	32.788	-15.024	57.895	10.084	QP
8		*	0.398	32.883	22.800	-15.012	47.895	10.084	AV
9			0.434	40.727	30.614	-16.449	57.176	10.113	QP
10			0.434	30.717	20.603	-16.459	47.176	10.113	AV
11			1.750	28.802	18.922	-27.198	56.000	9.880	QP
12			1.750	18.337	8.457	-27.663	46.000	9.880	AV

Note: Measure Level (dBμV) = Reading Level (dBμV) + Factor (dB)

Factor (dB) = Cable Loss (dB) + LISN Factor (dB)

Site: SR2	Time: 2017/08/02 - 18:50
Limit: FCC_Part 15.207_CE Main	Engineer: Kevin Ker
Probe: ENV216_101683_Filter On	Polarity: Neutral
EUT: AC220 Wi-Fi AP OD external antenna US	Power: AC 120V/60Hz

Test Mode: Mode 1

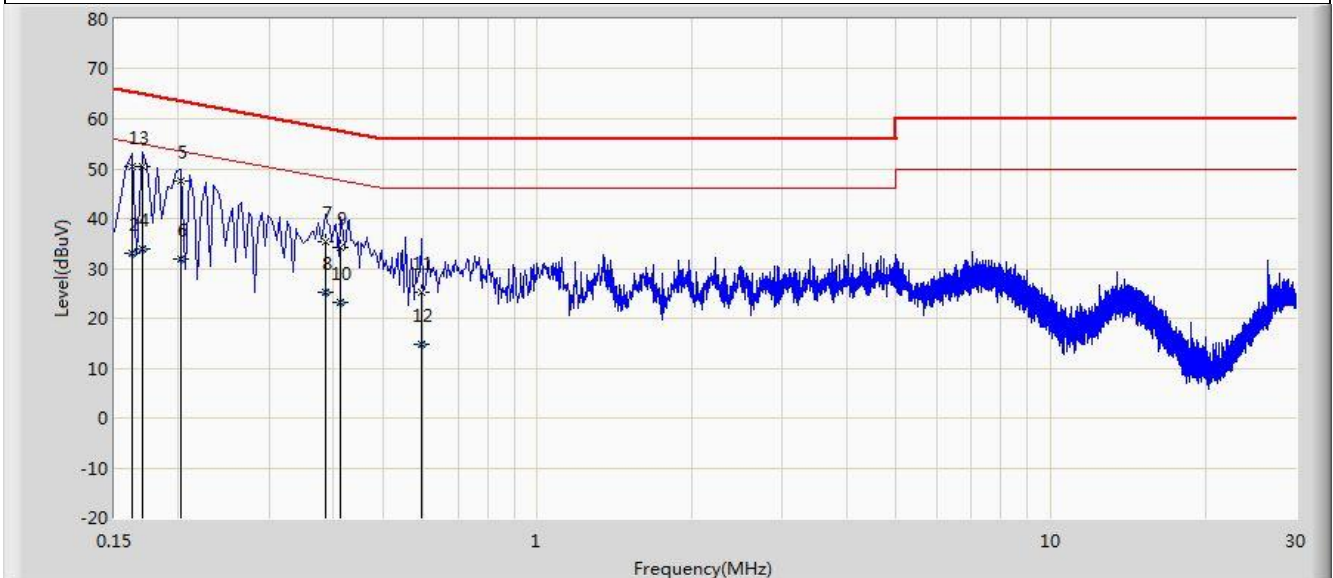

No	Flag	Mark	Frequency (MHz)	Measure Level (dBuV)	Reading Level (dBuV)	Margin (dB)	Limit (dBuV)	Factor (dB)	Type
1			0.162	50.457	40.379	-14.904	65.361	10.078	QP
2			0.162	33.033	22.955	-22.327	55.361	10.078	AV
3		*	0.170	50.466	40.402	-14.494	64.960	10.064	QP
4			0.170	34.032	23.968	-20.928	54.960	10.064	AV
5			0.202	47.517	37.509	-16.011	63.528	10.008	QP
6			0.202	31.973	21.965	-21.555	53.528	10.008	AV
7			0.386	35.299	25.197	-22.851	58.149	10.102	QP
8			0.386	25.189	15.087	-22.961	48.149	10.102	AV
9			0.414	34.344	24.221	-23.224	57.568	10.123	QP
10			0.414	23.138	13.015	-24.429	47.568	10.123	AV
11			0.594	25.254	15.119	-30.746	56.000	10.134	QP
12			0.162	50.457	40.379	-14.904	65.361	10.078	AV

Note: Measure Level (dBμV) = Reading Level (dBμV) + Factor (dB)

Factor (dB) = Cable Loss (dB) + LISN Factor (dB)

8. CONCLUSION

The data collected relate only the item(s) tested and show that the **AC220 Wi-Fi AP OD directional antenna US, AC220 Wi-Fi AP OD external antenna US, AC220 Wi-Fi AP OD small omni antenna US** is in compliance with FCC Rules.

The End