

## FCC Test Report

### (15.407, WLAN <DFS band>)

**Report No.:** RF151022E06A-1

**FCC ID:** 2AD8UFZCWM2A1

**Test Model:** WM2A-AC210m

**Received Date:** Dec. 10, 2015

**Test Date:** Dec. 10 to 16, 2015

**Issued Date:** Apr. 14, 2016

**Applicant:** Nokia Solutions and Networks.OY

**Address:** Karaportti 3, P.O. Box 226, Nokia Group, Finland.

**Issued By:** Bureau Veritas Consumer Products Services (H.K.) Ltd., Taoyuan Branch  
Hsin Chu Laboratory

**Lab Address:** E-2, No.1, Li Hsin 1st Road, Hsinchu Science Park, Hsinchu City 300,  
Taiwan R.O.C.

**Test Location (1):** E-2, No.1, Li Hsin 1st Road, Hsinchu Science Park, Hsinchu City 300,  
Taiwan R.O.C.

**Test Location (2):** No. 49, Ln. 206, Wende Rd., Shangshan Tsuen, Chiung Lin Hsiang, Hsin  
Chu Hsien 307, Taiwan R.O.C.



This report is for your exclusive use. Any copying or replication of this report to or for any other person or entity, or use of our name or trademark, is permitted only with our prior written permission. This report sets forth our findings solely with respect to the test samples identified herein. The results set forth in this report are not indicative or representative of the quality or characteristics of the lot from which a test sample was taken or any similar or identical product unless specifically and expressly noted. Our report includes all of the tests requested by you and the results thereof based upon the information that you provided to us. You have 60 days from date of issuance of this report to notify us of any material error or omission caused by our negligence, provided, however, that such notice shall be in writing and shall specifically address the issue you wish to raise. A failure to raise such issue within the prescribed time shall constitute your unqualified acceptance of the completeness of this report, the tests conducted and the correctness of the report contents. Unless specific mention, the uncertainty of measurement has been explicitly taken into account to declare the compliance or non-compliance to the specification. The report must not be used by the client to claim product certification, approval, or endorsement by TAF or any government agencies.

## Table of Contents

<b>Release Control Record</b> .....	<b>4</b>
<b>1 Certificate of Conformity</b> .....	<b>5</b>
<b>2 Summary of Test Results</b> .....	<b>6</b>
2.1 Measurement Uncertainty.....	6
2.2 Modification Record.....	6
<b>3 General Information</b> .....	<b>7</b>
3.1 General Description of EUT (WLAN, 15.407 <DFS band>).....	7
3.2 Description of Test Modes.....	9
3.2.1 Test Mode Applicability and Tested Channel Detail.....	10
3.3 Duty Cycle of Test Signal.....	13
3.4 Description of Support Units.....	14
3.4.1 Configuration of System under Test.....	14
3.5 General Description of Applied Standard.....	15
<b>4 Test Types and Results</b> .....	<b>16</b>
4.1 Radiated Emission and Bandedge Measurement.....	16
4.1.1 Limits of Radiated Emission and Bandedge Measurement.....	16
4.1.2 Test Instruments.....	17
4.1.3 Test Procedure.....	19
4.1.4 Deviation from Test Standard.....	19
4.1.5 Test Setup.....	20
4.1.6 EUT Operating Condition.....	20
4.1.7 Test Results (Mode 1 – Chain 0).....	21
4.1.8 Test Results (Mode 2 – Chain 1).....	41
4.1.9 Test Results (Mode 3 – 2TX).....	61
4.2 Conducted Emission Measurement.....	82
4.2.1 Limits of Conducted Emission Measurement.....	82
4.2.2 Test Instruments.....	82
4.2.3 Test Procedure.....	83
4.2.4 Deviation from Test Standard.....	83
4.2.5 Test Setup.....	83
4.2.6 EUT Operating Condition.....	83
4.2.7 Test Results.....	84
4.3 Transmit Power Measurement.....	86
4.3.1 Limits of Transmit Power Measurement.....	86
4.3.2 Test Setup.....	87
4.3.3 Test Instruments.....	87
4.3.4 Test Procedure.....	87
4.3.5 Deviation from Test Standard.....	87
4.3.6 EUT Operating Condition.....	87
4.3.7 Test Result (Mode 1 – Chain 0).....	88
4.3.8 Test Result (Mode 2 – Chain 1).....	93
4.3.9 Test Result (Mode 3 – 2TX).....	98
4.4 Peak Power Spectral Density Measurement.....	103
4.4.1 Limits of Peak Power Spectral Density Measurement.....	103
4.4.2 Test Setup.....	103
4.4.3 Test Instruments.....	103
4.4.4 Test Procedure.....	103
4.4.5 Deviation from Test Standard.....	103
4.4.6 EUT Operating Condition.....	103
4.4.7 Test Results (Mode 1 – Chain 0).....	104
4.4.8 Test Results (Mode 2 – Chain 1).....	107
4.4.9 Test Results (Mode 3 – 2TX).....	110
4.5 Frequency Stability Measurement.....	113

4.5.1	Limits of Frequency Stability Measurement .....	113
4.5.2	Test Setup .....	113
4.5.3	Test Instruments .....	113
4.5.4	Test Procedure .....	113
4.5.5	Deviation from Test Standard .....	113
4.5.6	EUT Operating Condition .....	113
4.5.7	Test Results .....	114
4.6	Occupied Bandwidth Measurement .....	115
4.6.1	Test Setup .....	115
4.6.2	Test Instruments .....	115
4.6.3	Test Procedure .....	115
4.6.4	Deviation from Test Standard .....	115
4.6.5	EUT Operating Conditions .....	115
4.6.6	Test Results (Mode 1 – Chain 0) .....	116
4.6.7	Test Results (Mode 2 – Chain 1) .....	118
4.6.8	Test Results (Mode 3 – 2TX) .....	120
4.7	26dB Bandwidth Measurement .....	122
4.7.1	Test Setup .....	122
4.7.2	Test Instruments .....	122
4.7.3	Test Procedure .....	122
4.7.4	Deviation from Test Standard .....	122
4.7.5	EUT Operating Condition .....	122
4.7.6	Test Results (Mode 1 – Chain 0) .....	123
4.7.7	Test Results (Mode 2 – Chain 1) .....	125
4.7.8	Test Results (Mode 3 – 2TX) .....	127
<b>5</b>	<b>Pictures of Test Arrangements .....</b>	<b>129</b>
	<b>Appendix – Information on the Testing Laboratories .....</b>	<b>130</b>



A D T

### Release Control Record

Issue No.	Description	Date Issued
RF151022E06A-1	Original release.	Apr. 14, 2016



## 2 Summary of Test Results

47 CFR FCC Part 15, Subpart E (SECTION 15.407)				
FCC Clause	FCC KDB 789033	Test Item	Result	Remarks
15.407(b)(6)	-	AC Power Conducted Emissions	PASS	Meet the requirement of limit. Minimum passing margin is -14.24dB at 0.29063MHz.
15.407(b)(1/2/3/4/6)	Section G	Radiated Emissions & Band Edge Measurement	PASS	Meet the requirement of limit. Minimum passing margin is -0.5dB at 5725.00MHz, 5470.00MHz & 5350.00MHz.
15.407(b)(1/2/3/4/6)	Section G	Conducted Emissions	PASS	Meet the requirement of limit.
15.407(a)(1/2/3)	Section E.3	Max Average Transmit Power	PASS	Meet the requirement of limit.
15.407(a)(1/2/3)	Section F	Peak Power Spectral Density	PASS	Meet the requirement of limit.
-	Section D	Occupied Bandwidth Measurement	PASS	Meet the requirement.
15.407(g)	-	Frequency Stability	PASS	Meet the requirement of limit.
15.203	-	Antenna Requirement	PASS	Antenna connector is MMCX not a standard connector.

**NOTE:** This report is prepared for FCC Class II permissive change. (Add DFS band <5250~5350MHz & 5470~5725MHz>).

### 2.1 Measurement Uncertainty

Where relevant, the following measurement uncertainty levels have been estimated for tests performed on the EUT as specified in CISPR 16-4-2:

Measurement	Frequency	Expanded Uncertainty (k=2) (±)
Conducted Emissions at mains ports	150kHz ~ 30MHz	2.86 dB
Radiated Emissions up to 1 GHz	30MHz ~ 1GHz	5.31 dB
Radiated Emissions above 1 GHz	1GHz ~ 6GHz	3.40 dB
	6GHz ~ 18GHz	3.73 dB
	18GHz ~ 40GHz	4.11 dB

### 2.2 Modification Record

There were no modifications required for compliance.

### 3 General Information

#### 3.1 General Description of EUT (WLAN, 15.407 <DFS band>)

Product	Wi-Fi AP Module 802.11 ac
Brand	Nokia
Test Model	WM2A-AC210m
Test Sample S/N	F3406027
Hardware Version	AM2
Status of EUT	MASS-PRODUCTION
Power Supply Rating	5.1Vdc from host equipment
Modulation Type	64QAM, 16QAM, QPSK, BPSK for OFDM 256QAM for OFDM in 11ac mode
Modulation Technology	OFDM
Transfer Rate	802.11a: up to 54Mbps 802.11n: up to 300Mbps 802.11ac: up to 866.7Mbps
Operating Frequency	5.26 ~ 5.32GHz, 5.5 ~ 5.70GHz
Number of Channel	15 for 802.11a, 802.11n (HT20), 802.11ac (VHT20) 7 for 802.11n (HT40), 802.11ac (VHT40) 3 for 802.11ac (VHT80)
Output Power	<p><b>1TX (Chain 0) Mode:</b>  <b>5.26 ~ 5.32GHz:</b>            802.11a: 180.302mW            802.11ac (VHT20): 182.81mW            802.11ac (VHT40): 174.181mW            802.11ac (VHT80): 88.716mW  <b>5.5 ~ 5.7GHz:</b>            802.11a: 182.39mW            802.11ac (VHT20): 180.717mW            802.11ac (VHT40): 163.305mW            802.11ac (VHT80): 174.181mW  <b>1TX (Chain 1) Mode:</b>  <b>5.26 ~ 5.32GHz:</b>            802.11a: 193.642mW            802.11ac (VHT20): 190.985mW            802.11ac (VHT40): 190.985mW            802.11ac (VHT80): 118.577mW  <b>5.5 ~ 5.7GHz:</b>            802.11a: 191.867mW            802.11ac (VHT20): 186.638mW            802.11ac (VHT40): 190.985mW            802.11ac (VHT80): 113.763mW  <b>2TX Mode:</b>  <b>5.26 ~ 5.32GHz:</b>            802.11a: 130.067mW            802.11ac (VHT20): 134.73mW            802.11ac (VHT40): 223.973mW            802.11ac (VHT80): 65.048mW  <b>5.5 ~ 5.58GHz &amp; 5.66~5.7GHz:</b>            802.11a: 139.486mW            802.11ac (VHT20): 130.456mW            802.11ac (VHT40): 236.866mW            802.11ac (VHT80): 242.038mW</p>

Antenna Type	Refer to note as below
Antenna Connector	Refer to note as below
Accessory Device	NA
Data Cable Supplied	NA

**Note:**

- This report is prepared for FCC Class II permissive change. This report is used in conjunction with report No: RF151022E06 and adds the following additional information:
  - ◆ Add DFS band <5250~5350MHz & 5470~5725MHz>
- According to above condition, all test items need to be performed. And all data were verified to meet the requirements.
- The emission of the simultaneous operation (2.4GHz and 5GHz) has been evaluated and no non-compliance was found.
- The antennas provided to the EUT, please refer to the following table:

**WLAN – 5GHz Antenna spec.**

Antenna No	PCB Chain No.	Brand	Model	Antenna Type	Gain(dBi)	Frequency (GHz to GHz)
1	U20	Galtronics	02102140-06084A4	PIFA	6.03	5.15~5.25
					6.17	5.25~5.35
					5.57	5.47~5.725
					5.18	5.725~5.85
2	U21	Galtronics	02102140-06084A1	PIFA	5.1	5.15~5.25
					4.91	5.25~5.35
					5.23	5.47~5.725
					5.73	5.725~5.85

**Cable Spec.**

Antenna No	Brand	Model	Connector Type	Cable Loss(dB)	Cable Length (cm)
1	Galtronics	LL100	MMCX	0	30.6
2	Galtronics	LL100	MMCX	0	9.1

- The EUT incorporates a MIMO function.

**5GHz Band**

MODULATION MODE	DATA RATE (MCS)	TX & RX CONFIGURATION	
<b>802.11a</b>	6 ~ 54Mbps	2TX	2RX
<b>802.11n (HT20)</b>	MCS 0~7	2TX	2RX
	MCS 8~15	2TX	2RX
<b>802.11n (HT40)</b>	MCS 0~7	2TX	2RX
	MCS 8~15	2TX	2RX
<b>802.11ac (VHT20)</b>	MCS 0~8, Nss=1	2TX	2RX
	MCS 0~8, Nss=2	2TX	2RX
<b>802.11ac (VHT40)</b>	MCS 0~9, Nss=1	2TX	2RX
	MCS 0~9, Nss=2	2TX	2RX
<b>802.11ac (VHT80)</b>	MCS 0~9, Nss=1	2TX	2RX
	MCS 0~9, Nss=2	2TX	2RX

- The above EUT information is declared by manufacturer and for more detailed features description, please refer to the manufacturer's specifications or user's manual.



### 3.2 Description of Test Modes

#### FOR 5260 ~ 5320MHz

4 channels are provided for 802.11a, 802.11n (HT20), 802.11ac (VHT20):

Channel	Frequency	Channel	Frequency
52	5260 MHz	60	5300 MHz
56	5280 MHz	64	5320 MHz

2 channels are provided for 802.11n (40MHz), 802.11ac (VHT40):

Channel	Frequency	Channel	Frequency
54	5270 MHz	62	5310 MHz

1 channel is provided for 802.11ac (VHT80):

Channel	Frequency
58	5290MHz

#### FOR 5500 ~ 5700MHz

11 channels are provided for 802.11a, 802.11n (HT20), 802.11ac (VHT20):

Channel	Frequency	Channel	Frequency
100	5500 MHz	124	5620 MHz
104	5520 MHz	128	5640 MHz
108	5540 MHz	132	5660 MHz
112	5560 MHz	136	5680 MHz
116	5580 MHz	140	5700 MHz
120	5600 MHz		

5 channels are provided for 802.11n (HT40), 802.11ac (VHT40):

Channel	Frequency	Channel	Frequency
102	5510 MHz	126	5630 MHz
110	5550 MHz	134	5670 MHz
118	5590 MHz		

2 channels are provided for 802.11ac (VHT80):

Channel	Frequency	Channel	Frequency
106	5530MHz	122	5610 MHz

### 3.2.1 Test Mode Applicability and Tested Channel Detail

EUT CONFIGURE MODE	APPLICABLE TO				DESCRIPTION
	RE $\geq$ 1G	RE $<$ 1G	PLC	APCM	
1	√	-	√	√	1TX (Chain 0)
2	√	-	√	√	1TX (Chain 1)
3	√	√	√	√	2TX

Where **RE $\geq$ 1G**: Radiated Emission above 1GHz      **RE $<$ 1G**: Radiated Emission below 1GHz  
**PLC**: Power Line Conducted Emission      **APCM**: Antenna Port Conducted Measurement

NOTE: 1. "-" means no effect.

2. The EUT had been pre-tested on the positioned of each 3 axis. The worst case was found when positioned on Z-plane (for below 1GHz) and Y-plane (for above 1GHz).

#### **Radiated Emission Test (Above 1GHz):**

- Pre-Scan has been conducted to determine the worst-case mode from all possible combinations between available modulations, data rates and antenna ports (if EUT with antenna diversity architecture).
- Following channel(s) was (were) selected for the final test as listed below.

EUT CONFIGURE MODE	MODE	FREQ. BAND (MHz)	AVAILABLE CHANNEL	TESTED CHANNEL	MODULATION TECHNOLOGY	MODULATION TYPE	DATA RATE (Mbps)
1	802.11a	5260-5320	52 to 64	52, 60, 64	OFDM	BPSK	6
	802.11ac (VHT20)		52 to 64	52, 60, 64	OFDM	BPSK	6.5
	802.11ac (VHT40)		54 to 62	54, 62	OFDM	BPSK	13.5
	802.11ac (VHT80)		58	58	OFDM	BPSK	29.3
	802.11a	5500-5700	100 to 140	100, 116, 140	OFDM	BPSK	6
	802.11ac (VHT20)		100 to 140	100, 116, 140	OFDM	BPSK	6.5
	802.11ac (VHT40)		102 to 134	102, 110, 134	OFDM	BPSK	13.5
	802.11ac (VHT80)		106 to 122	106, 122	OFDM	BPSK	29.3
EUT CONFIGURE MODE	MODE	FREQ. BAND (MHz)	AVAILABLE CHANNEL	TESTED CHANNEL	MODULATION TECHNOLOGY	MODULATION TYPE	DATA RATE (Mbps)
2	802.11a	5260-5320	52 to 64	52, 60, 64	OFDM	BPSK	6
	802.11ac (VHT20)		52 to 64	52, 60, 64	OFDM	BPSK	6.5
	802.11ac (VHT40)		54 to 62	54, 62	OFDM	BPSK	13.5
	802.11ac (VHT80)		58	58	OFDM	BPSK	29.3
	802.11a	5500-5700	100 to 140	100, 116, 140	OFDM	BPSK	6
	802.11ac (VHT20)		100 to 140	100, 116, 140	OFDM	BPSK	6.5
	802.11ac (VHT40)		102 to 134	102, 110, 134	OFDM	BPSK	13.5
	802.11ac (VHT80)		106 to 122	106, 122	OFDM	BPSK	29.3

EUT CONFIGURE MODE	MODE	FREQ. BAND (MHz)	AVAILABLE CHANNEL	TESTED CHANNEL	MODULATION TECHNOLOGY	MODULATION TYPE	DATA RATE (Mbps)
3	802.11a	5260-5320	52 to 64	52, 60, 64	OFDM	BPSK	6
	802.11ac (VHT20)		52 to 64	52, 60, 64	OFDM	BPSK	6.5
	802.11ac (VHT40)		54 to 62	54, 62	OFDM	BPSK	13.5
	802.11ac (VHT80)		58	58	OFDM	BPSK	29.3
	802.11a	5500-5700	100 to 140	100, 116, 140	OFDM	BPSK	6
	802.11ac (VHT20)		100 to 140	100, 116, 140	OFDM	BPSK	6.5
	802.11ac (VHT40)		102 to 134	102, 110, 134	OFDM	BPSK	13.5
	802.11ac (VHT80)		106 to 122	106, 122	OFDM	BPSK	29.3

**Radiated Emission Test (Below 1GHz):**

- Pre-Scan has been conducted to determine the worst-case mode from all possible combinations between available modulations, data rates and antenna ports (if EUT with antenna diversity architecture).
- Following channel(s) was (were) selected for the final test as listed below.

EUT CONFIGURE MODE	AVAILABLE CHANNEL	MODE	FREQ. BAND (MHz)	AVAILABLE CHANNEL	TESTED CHANNEL	MODULATION TECHNOLOGY	MODULATION TYPE	DATA RATE (Mbps)
3	54 to 62 100 to 116, 132 to 140	802.11ac (VHT80)	5260-5320 5500-5700	54 to 62 100 to 140	122	OFDM	BPSK	13.5

**Power Line Conducted Emission Test:**

- Pre-Scan has been conducted to determine the worst-case mode from all possible combinations between available modulations, data rates and antenna ports (if EUT with antenna diversity architecture).
- Following channel(s) was (were) selected for the final test as listed below.

EUT CONFIGURE MODE	AVAILABLE CHANNEL	MODE	FREQ. BAND (MHz)	AVAILABLE CHANNEL	TESTED CHANNEL	MODULATION TECHNOLOGY	MODULATION TYPE	DATA RATE (Mbps)
3	54 to 62 100 to 116, 132 to 140	802.11ac (VHT40)	5260-5320 5500-5700	54 to 62 100 to 140	54	OFDM	BPSK	13.5

**Antenna Port Conducted Measurement:**

- This item includes all test value of each mode, but only includes spectrum plot of worst value of each mode.
- Pre-Scan has been conducted to determine the worst-case mode from all possible combinations between available modulations, data rates and antenna ports (if EUT with antenna diversity architecture).
- Following channel(s) was (were) selected for the final test as listed below.

EUT CONFIGURE MODE	MODE	FREQ. BAND (MHz)	AVAILABLE CHANNEL	TESTED CHANNEL	MODULATION TECHNOLOGY	MODULATION TYPE	DATA RATE (Mbps)
1	802.11a	5260-5320	52 to 64	52, 60, 64	OFDM	BPSK	6
	802.11ac (VHT20)		52 to 64	52, 60, 64	OFDM	BPSK	6.5
	802.11ac (VHT40)		54 to 62	54, 62	OFDM	BPSK	13.5
	802.11ac (VHT80)		58	58	OFDM	BPSK	29.3
	802.11a	5500-5700	100 to 140	100, 116, 140	OFDM	BPSK	6
	802.11ac (VHT20)		100 to 140	100, 116, 140	OFDM	BPSK	6.5
	802.11ac (VHT40)		102 to 134	102, 110, 134	OFDM	BPSK	13.5
	802.11ac (VHT80)		106 to 122	106, 122	OFDM	BPSK	29.3
EUT CONFIGURE MODE	MODE	FREQ. BAND (MHz)	AVAILABLE CHANNEL	TESTED CHANNEL	MODULATION TECHNOLOGY	MODULATION TYPE	DATA RATE (Mbps)
2	802.11a	5260-5320	52 to 64	52, 60, 64	OFDM	BPSK	6
	802.11ac (VHT20)		52 to 64	52, 60, 64	OFDM	BPSK	6.5
	802.11ac (VHT40)		54 to 62	54, 62	OFDM	BPSK	13.5
	802.11ac (VHT80)		58	58	OFDM	BPSK	29.3
	802.11a	5500-5700	100 to 140	100, 116, 140	OFDM	BPSK	6
	802.11ac (VHT20)		100 to 140	100, 116, 140	OFDM	BPSK	6.5
	802.11ac (VHT40)		102 to 134	102, 110, 134	OFDM	BPSK	13.5
	802.11ac (VHT80)		106 to 122	106, 122	OFDM	BPSK	29.3
EUT CONFIGURE MODE	MODE	FREQ. BAND (MHz)	AVAILABLE CHANNEL	TESTED CHANNEL	MODULATION TECHNOLOGY	MODULATION TYPE	DATA RATE (Mbps)
3	802.11a	5260-5320	52 to 64	52, 60, 64	OFDM	BPSK	6
	802.11ac (VHT20)		52 to 64	52, 60, 64	OFDM	BPSK	6.5
	802.11ac (VHT40)		54 to 62	54, 62	OFDM	BPSK	13.5
	802.11ac (VHT80)		58	58	OFDM	BPSK	29.3
	802.11a	5500-5700	100 to 140	100, 116, 140	OFDM	BPSK	6
	802.11ac (VHT20)		100 to 140	100, 116, 140	OFDM	BPSK	6.5
	802.11ac (VHT40)		102 to 134	102, 110, 134	OFDM	BPSK	13.5
	802.11ac (VHT80)		106 to 122	106, 122	OFDM	BPSK	29.3

**Test Condition:**

APPLICABLE TO	ENVIRONMENTAL CONDITIONS	INPUT POWER (SYSTEM)	TESTED BY
RE≥1G	23deg. C, 64%RH	120Vac, 60Hz	Jyunchun Lin
RE<1G	24deg. C, 66%RH	120Vac, 60Hz	Jyunchun Lin
PLC	23deg. C, 67%RH	120Vac, 60Hz	Jason Huang
APCM	25deg. C, 60%RH	120Vac, 60Hz	Anderson Chen

### 3.3 Duty Cycle of Test Signal

If duty cycle of test signal is  $\geq 98\%$ , duty factor is not required.

If duty cycle of test signal is  $< 98\%$ , duty factor shall be considered.

**802.11a:** Duty cycle =  $5.346 \text{ ms} / 5.44 \text{ ms} = 0.983$

**802.11ac (VHT20):** Duty cycle =  $4.966 \text{ ms} / 5.045 \text{ ms} = 0.981$

**802.11ac (VHT40):** Duty cycle =  $2.405 \text{ ms} / 2.487 \text{ ms} = 0.967$ , Duty factor =  $10 * \log(1/0.967) = 0.15$

**802.11ac (VHT80):** Duty cycle =  $1.134 \text{ ms} / 1.211 \text{ ms} = 0.936$ , Duty factor =  $10 * \log(1/0.936) = 0.29$

**802.11a**

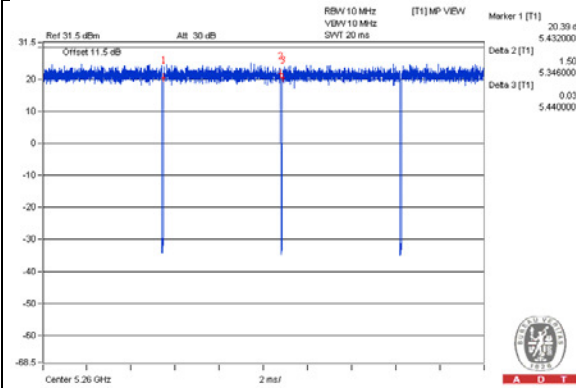

**802.11ac (VHT20)**

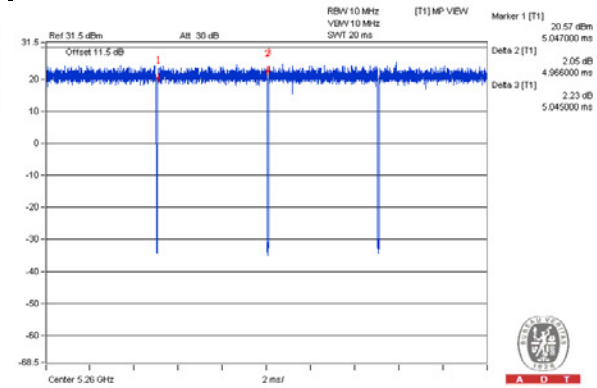

**802.11ac (VHT40)**

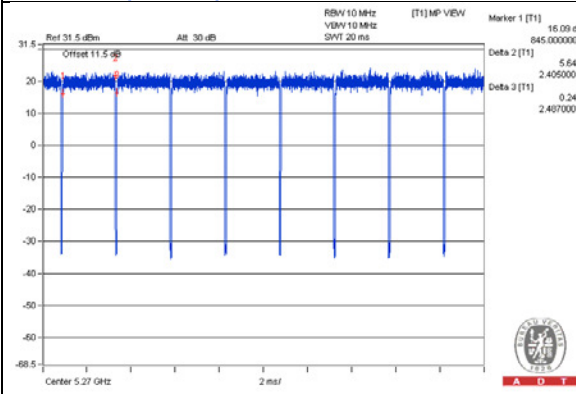

**802.11ac (VHT80)**

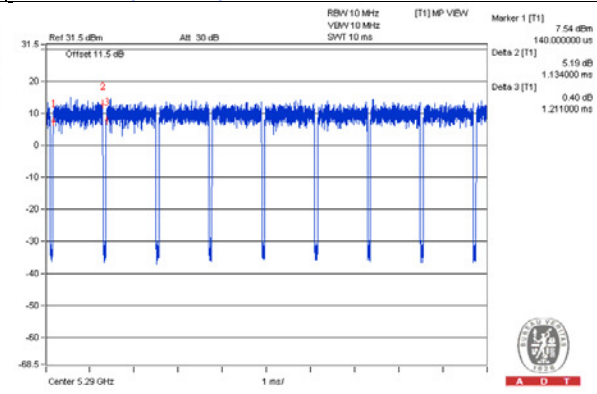

### 3.4 Description of Support Units

The EUT has been tested as an independent unit together with other necessary accessories or support units. The following support units or accessories were used to form a representative test configuration during the tests.

No.	Product	Brand	Model No.	Serial No.	FCC ID	Remark
A	Notebook Computer	DELL	E5430	4YV4VY1	FCC DoC	Provided by Lab
B	Test tool	CIG SHANGHAI	NA	NA	NA	Supplied by Client
C	Adapter	HUAWEI	HW-120150C1W	NA	NA	Supplied by Client

**NOTE:**

1. All power cords of the above support units are non-shielded (1.8 m).

No.	Cable	Qty.	Length (m)	Shielded (Yes/ No)	Cores (Number)	Remark
1	DC	1	1.5	No	0	Supplied by Client
2	RJ-45	1	10	No	0	Provided by Lab
3	Console	1	0.7	No	0	Provided by Lab

#### 3.4.1 Configuration of System under Test

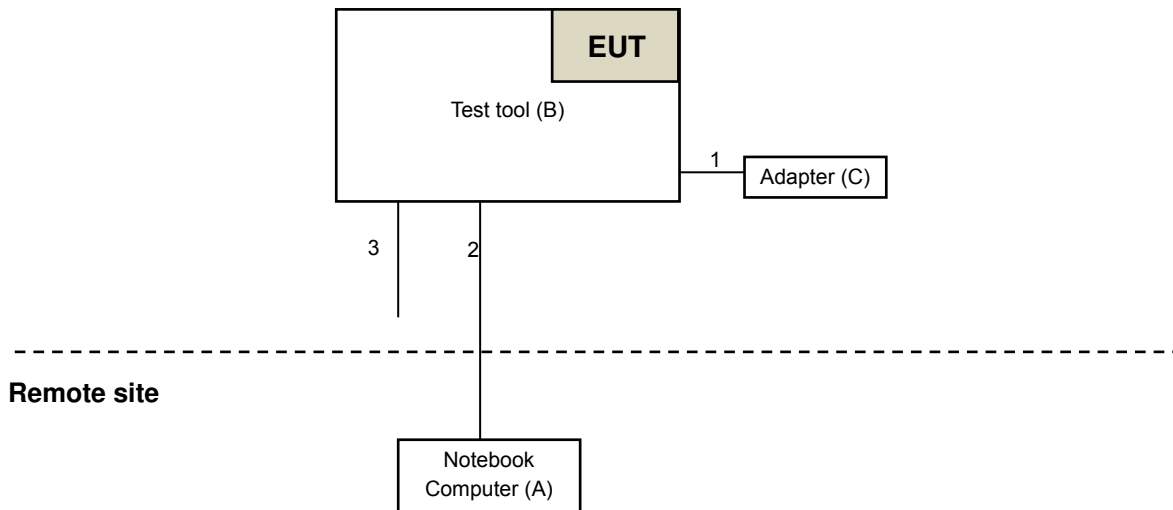

### 3.5 General Description of Applied Standard

The EUT is a RF Product. According to the specifications of the manufacturer, it must comply with the requirements of the following standards:

**FCC Part 15, Subpart E (15.407)**

**KDB 789033 D02 General UNII Test Procedure New Rules v01r02**

**KDB 662911 D01 Multiple Transmitter Output v02r01**

**ANSI C63.10-2013**

All test items have been performed and recorded as per the above standards.

## 4 Test Types and Results

### 4.1 Radiated Emission and Bandedge Measurement

#### 4.1.1 Limits of Radiated Emission and Bandedge Measurement

Radiated emissions which fall in the restricted bands must comply with the radiated emission limits specified as below table.

Frequencies (MHz)	Field Strength (microvolts/meter)	Measurement Distance (meters)
0.009 ~ 0.490	2400/F(kHz)	300
0.490 ~ 1.705	24000/F(kHz)	30
1.705 ~ 30.0	30	30
30 ~ 88	100	3
88 ~ 216	150	3
216 ~ 960	200	3
Above 960	500	3

#### NOTE:

- The lower limit shall apply at the transition frequencies.
- Emission level (dBuV/m) = 20 log Emission level (uV/m).
- For frequencies above 1000MHz, the field strength limits are based on average detector, however, the peak field strength of any emission shall not exceed the maximum permitted average limits, specified above by more than 20dB under any condition of modulation.

#### LIMITS OF UNWANTED EMISSION OUT OF THE RESTRICTED BANDS

APPLICABLE TO	LIMIT	
789033 D02 General UNII Test Procedure New Rules v01	FIELD STRENGTH AT 3m	
	PK:74 (dBuV/m)	AV:54 (dBuV/m)
APPLICABLE TO	EIRP LIMIT	EQUIVALENT FIELD STRENGTH AT 3m
15.407(b)(1)	PK:-27 (dBm/MHz)	PK:68.2(dBuV/m)
15.407(b)(2)		
15.407(b)(3)		
15.407(b)(4)	PK:-27 (dBm/MHz) <sup>*1</sup> PK:-17 (dBm/MHz) <sup>*2</sup>	PK: 68.2(dBuV/m) <sup>*1</sup> PK:78.2 (dBuV/m) <sup>*2</sup>

**NOTE:** <sup>\*1</sup> beyond 10MHz of the band edge <sup>\*2</sup> within 10 MHz of band edge

The following formula is used to convert the equipment isotropic radiated power (eirp) to field strength:

$$E = \frac{1000000\sqrt{30P}}{3} \mu\text{V/m, where P is the eirp (Watts).$$





4.1.2 Test Instruments

DESCRIPTION & MANUFACTURER	MODEL NO.	SERIAL NO.	CALIBRATED DATE	CALIBRATED UNTIL
Test Receiver Agilent	N9038A	MY50010156	Aug. 12, 2015	Aug. 11, 2016
Pre-Amplifier <sup>(*)</sup> EMCI	EMC001340	980142	Jan. 13, 2014	Jan. 12, 2016
Loop Antenna <sup>(*)</sup> Electro-Metrics	EM-6879	264	Dec. 16, 2014	Dec. 15, 2016
RF Cable	NA	LOOPCAB-001 LOOPCAB-002	Jan. 18, 2015	Jan. 17, 2016
Pre-Amplifier Mini-Circuits	ZFL-1000VH2 B	AMP-ZFL-07	May 08, 2015	May 07, 2016
Trilog Broadband Antenna SCHWARZBECK	VULB 9168	138	Feb. 03, 2015	Feb. 02, 2016
RF Cable	8D	966-3-1 966-3-2 966-3-3	Apr. 03, 2015	Apr. 02, 2016
Horn_Antenna SCHWARZBECK	BBHA9120-D	9120D-406	Feb. 05, 2015	Feb. 04, 2016
Pre-Amplifier Agilent	8449B	3008A02465	Apr. 06, 2015	Apr. 05, 2016
RF Cable	EMC104-SM- SM-2000 EMC104-SM- SM-5000 EMC104-SM- SM-5000	150317 150321 150322	Mar. 31, 2015	Mar. 30, 2016
Spectrum Analyzer Keysight	N9030A	MY54490520	July 26, 2015	July 25, 2016
Pre-Amplifier EMCI	EMC184045	980143	Jan. 16, 2015	Jan. 15, 2016
Horn_Antenna SCHWARZBECK	BBHA 9170	BBHA9170608	Feb. 05, 2015	Feb. 04, 2016
RF Cable	SUCOFLEX 102	36432/2 36441/2	Jan. 17, 2015	Jan. 16, 2016
Power Meter Anritsu	ML2495A	1014008	Apr. 28, 2015	Apr. 27, 2016
Power Sensor Anritsu	MA2411B	0917122	Apr. 28, 2015	Apr. 27, 2016
Spectrum Analyzer R&S	FSP40	100060	May 08, 2015	May 07, 2016
Software	ADT_Radiated _V8.7.07	NA	NA	NA
Antenna Tower & Turn Table CT	NA	NA	NA	NA
Spectrum Analyzer R&S	FSP40	100060	May 08, 2015	May 07, 2016
Power Meter Anritsu	ML2495A	1014008	Apr. 28, 2015	Apr. 27, 2016
Power Sensor Anritsu	MA2411B	0917122	Apr. 28, 2015	Apr. 27, 2016

**Note:**

1. The calibration interval of the above test instruments is 12 months and the calibrations are traceable to NML/ROC and NIST/USA.
2. \*The calibration interval of the above test instruments is 24 months and the calibrations are traceable to NML/ROC and NIST/USA.
3. Loop antenna was used for all emissions below 30 MHz.
4. The test was performed in 966 Chamber No. 3.
- 5 The FCC Site Registration No. is 147459
6. The CANADA Site Registration No. is 20331-1
7. Tested Date: Dec. 10 to 15, 2015

#### 4.1.3 Test Procedure

- a. The EUT was placed on the top of a rotating table 0.8 meters (for below 1GHz) / 1.5 meters (for above 1GHz) above the ground at 3 meter chamber room for test. The table was rotated 360 degrees to determine the position of the highest radiation.
- b. The EUT was set 3 meters away from the interference-receiving antenna, which was mounted on the top of a variable-height antenna tower.
- c. The height of antenna is varied from one meter to four meters above the ground to determine the maximum value of the field strength. Both horizontal and vertical polarizations of the antenna are set to make the measurement.
- d. For each suspected emission, the EUT was arranged to its worst case and then the antenna was tuned to heights from 1 meter to 4 meters and the rotatable table was turned from 0 degrees to 360 degrees to find the maximum reading.
- e. The test-receiver system was set to quasi-peak detect function and specified bandwidth with maximum hold mode when the test frequency is below 1 GHz.
- f. The test-receiver system was set to peak and average detect function and specified bandwidth with maximum hold mode when the test frequency is above 1 GHz. If the peak reading value also meets average limit, measurement with the average detector is unnecessary.

#### Note:

1. The resolution bandwidth and video bandwidth of test receiver/spectrum analyzer is 120kHz for Quasi-peak detection (QP) at frequency below 1GHz.
2. The resolution bandwidth of test receiver/spectrum analyzer is 1 MHz and the video bandwidth is 3 MHz for Peak detection (PK) at frequency above 1GHz.
3. The resolution bandwidth of test receiver/spectrum analyzer is 1MHz and the video bandwidth is 3MHz for RMS Average (Duty cycle < 98%) for Average detection (AV) at frequency above 1GHz, then the measurement results was added to a correction factor ( $10 \log(1/\text{duty cycle})$ ).
4. The resolution bandwidth of test receiver/spectrum analyzer is 1MHz and the video bandwidth is 10Hz (Duty cycle  $\geq 98\%$ ) for Average detection (AV) at frequency above 1GHz.
5. All modes of operation were investigated and the worst-case emissions are reported.

#### 4.1.4 Deviation from Test Standard

No deviation.

#### 4.1.5 Test Setup

##### <Frequency Range below 1GHz>

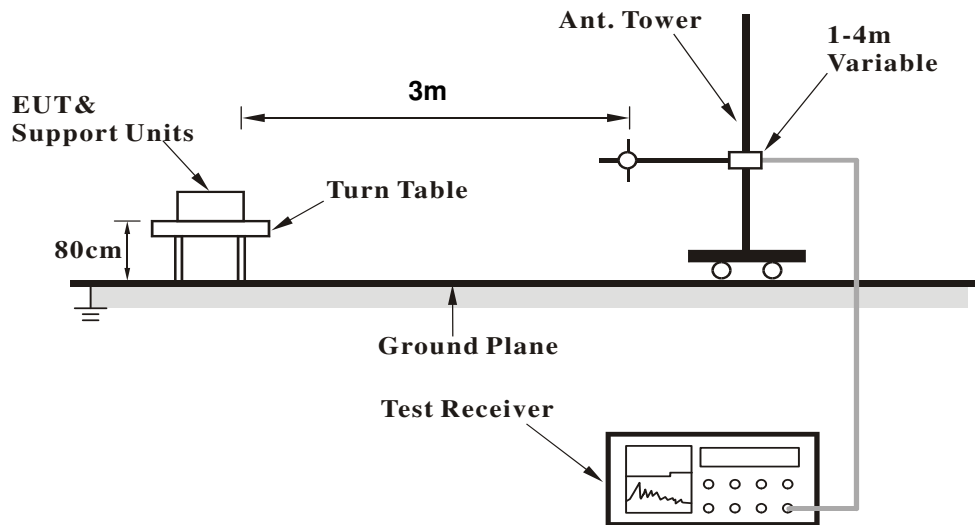

##### <Frequency Range above 1GHz>

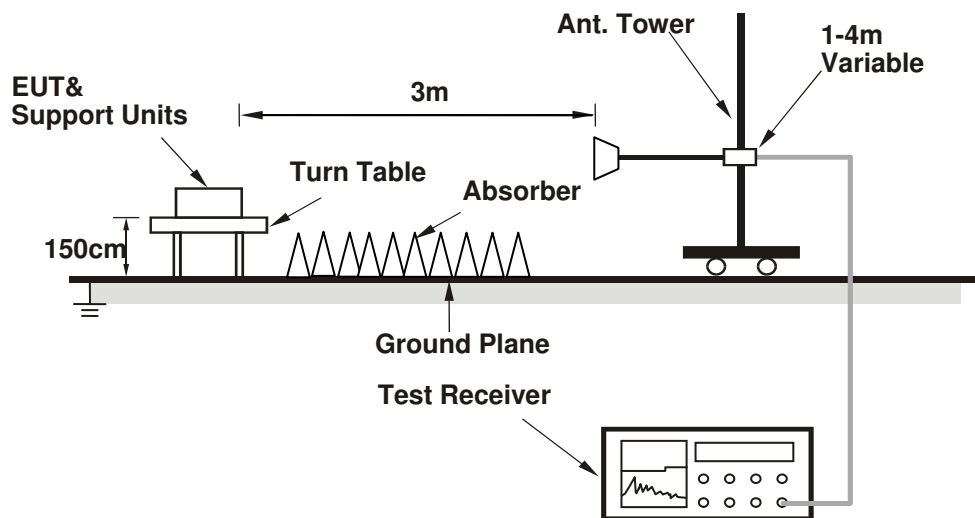

For the actual test configuration, please refer to the attached file (Test Setup Photo).

#### 4.1.6 EUT Operating Condition

1. Connect the EUT with the support unit A (Notebook Computer) which is placed in remote site.
2. The communication partner run test program "cart.exe paste command" to enable EUT under transmission/receiving condition continuously at specific channel frequency.

**4.1.7 Test Results (Mode 1 – Chain 0)**
**Above 1GHz Data:**
**802.11a**

<b>CHANNEL</b>	TX Channel 52	<b>DETECTOR FUNCTION</b>	Peak (PK)
<b>FREQUENCY RANGE</b>	1GHz ~ 40GHz		Average (AV)

**ANTENNA POLARITY & TEST DISTANCE: HORIZONTAL AT 3 M**

NO.	FREQ. (MHz)	EMISSION LEVEL (dBuV/m)	LIMIT (dBuV/m)	MARGIN (dB)	ANTENNA HEIGHT (m)	TABLE ANGLE (Degree)	RAW VALUE (dBuV)	CORRECTION FACTOR (dB/m)
1	5150.00	51.7 PK	74.0	-22.3	1.88 H	221	43.37	8.33
2	5150.00	38.9 AV	54.0	-15.1	1.88 H	221	30.57	8.33
3	*5260.00	108.7 PK			1.88 H	221	100.07	8.63
4	*5260.00	98.2 AV			1.88 H	221	89.57	8.63
5	5350.00	54.0 PK	74.0	-20.0	1.88 H	221	45.20	8.80
6	5350.00	41.4 AV	54.0	-12.6	1.88 H	221	32.60	8.80
7	#10520.00	49.1 PK	74.0	-24.9	1.66 H	207	34.64	14.46
8	#10520.00	36.5 AV	54.0	-17.5	1.66 H	207	22.04	14.46
9	15780.00	51.2 PK	74.0	-22.8	1.54 H	309	31.98	19.22
10	15780.00	40.4 AV	54.0	-13.6	1.54 H	309	21.18	19.22

**ANTENNA POLARITY & TEST DISTANCE: VERTICAL AT 3 M**

NO.	FREQ. (MHz)	EMISSION LEVEL (dBuV/m)	LIMIT (dBuV/m)	MARGIN (dB)	ANTENNA HEIGHT (m)	TABLE ANGLE (Degree)	RAW VALUE (dBuV)	CORRECTION FACTOR (dB/m)
1	5150.00	54.3 PK	74.0	-19.7	1.44 V	185	45.97	8.33
2	5150.00	42.6 AV	54.0	-11.4	1.44 V	185	34.27	8.33
3	*5260.00	112.6 PK			1.44 V	185	103.97	8.63
4	*5260.00	102.4 AV			1.44 V	185	93.77	8.63
5	5350.00	57.6 PK	74.0	-16.4	1.44 V	185	48.80	8.80
6	5350.00	45.6 AV	54.0	-8.4	1.44 V	185	36.80	8.80
7	#10520.00	50.5 PK	74.0	-23.5	1.66 V	205	36.04	14.46
8	#10520.00	37.4 AV	54.0	-16.6	1.66 V	205	22.94	14.46
9	15780.00	51.2 PK	74.0	-22.8	1.53 V	171	31.98	19.22
10	15780.00	40.9 AV	54.0	-13.1	1.53 V	171	21.68	19.22

**REMARKS:**

- Emission Level(dBuV/m) = Raw Value(dBuV) + Correction Factor(dB/m)
- Correction Factor(dB/m) = Antenna Factor(dB/m) + Cable Factor(dB) – Pre-Amplifier Factor(dB)
- The other emission levels were very low against the limit.
- Margin value = Emission Level – Limit value
- " \* ": Fundamental frequency.
- " # ": The radiated frequency is out of the restricted band.

<b>CHANNEL</b>	TX Channel 60	<b>DETECTOR FUNCTION</b>	Peak (PK)
<b>FREQUENCY RANGE</b>	1GHz ~ 40GHz		Average (AV)

**ANTENNA POLARITY & TEST DISTANCE: HORIZONTAL AT 3 M**

NO.	FREQ. (MHz)	EMISSION LEVEL (dBuV/m)	LIMIT (dBuV/m)	MARGIN (dB)	ANTENNA HEIGHT (m)	TABLE ANGLE (Degree)	RAW VALUE (dBuV)	CORRECTION FACTOR (dB/m)
1	*5300.00	108.3 PK			1.91 H	233	99.61	8.69
2	*5300.00	97.9 AV			1.91 H	233	89.21	8.69
3	5351.10	53.8 PK	74.0	-20.2	1.91 H	233	44.99	8.81
4	5351.10	41.7 AV	54.0	-12.3	1.91 H	233	32.89	8.81
5	10600.00	49.7 PK	74.0	-24.3	1.67 H	196	35.16	14.54
6	10600.00	36.9 AV	54.0	-17.1	1.67 H	196	22.36	14.54
7	15900.00	51.4 PK	74.0	-22.6	1.51 H	315	32.01	19.39
8	15900.00	40.5 AV	54.0	-13.5	1.51 H	315	21.11	19.39

**ANTENNA POLARITY & TEST DISTANCE: VERTICAL AT 3 M**

NO.	FREQ. (MHz)	EMISSION LEVEL (dBuV/m)	LIMIT (dBuV/m)	MARGIN (dB)	ANTENNA HEIGHT (m)	TABLE ANGLE (Degree)	RAW VALUE (dBuV)	CORRECTION FACTOR (dB/m)
1	*5300.00	112.1 PK			1.45 V	183	103.41	8.69
2	*5300.00	102.1 AV			1.45 V	183	93.41	8.69
3	5351.10	57.7 PK	74.0	-16.3	1.45 V	183	48.89	8.81
4	5351.10	45.6 AV	54.0	-8.4	1.45 V	183	36.79	8.81
5	10600.00	50.0 PK	74.0	-24.0	1.61 V	209	35.46	14.54
6	10600.00	37.2 AV	54.0	-16.8	1.61 V	209	22.66	14.54
7	15900.00	50.9 PK	74.0	-23.1	1.53 V	160	31.51	19.39
8	15900.00	40.7 AV	54.0	-13.3	1.53 V	160	21.31	19.39

**REMARKS:**

1. Emission Level(dBuV/m) = Raw Value(dBuV) + Correction Factor(dB/m)
2. Correction Factor(dB/m) = Antenna Factor(dB/m) + Cable Factor(dB) – Pre-Amplifier Factor(dB)
3. The other emission levels were very low against the limit.
4. Margin value = Emission Level – Limit value
5. " \* ": Fundamental frequency.



<b>CHANNEL</b>	TX Channel 64	<b>DETECTOR FUNCTION</b>	Peak (PK)
<b>FREQUENCY RANGE</b>	1GHz ~ 40GHz		Average (AV)

**ANTENNA POLARITY & TEST DISTANCE: HORIZONTAL AT 3 M**

NO.	FREQ. (MHz)	EMISSION LEVEL (dBuV/m)	LIMIT (dBuV/m)	MARGIN (dB)	ANTENNA HEIGHT (m)	TABLE ANGLE (Degree)	RAW VALUE (dBuV)	CORRECTION FACTOR (dB/m)
1	*5320.00	108.7 PK			1.98 H	214	99.97	8.73
2	*5320.00	98.3 AV			1.98 H	214	89.57	8.73
3	5350.00	54.0 PK	74.0	-20.0	1.98 H	214	45.20	8.80
4	5350.00	42.1 AV	54.0	-11.9	1.98 H	214	33.30	8.80
5	10640.00	49.1 PK	74.0	-24.9	1.71 H	216	34.52	14.58
6	10640.00	36.7 AV	54.0	-17.3	1.71 H	216	22.12	14.58
7	15960.00	51.0 PK	74.0	-23.0	1.57 H	314	31.65	19.35
8	15960.00	40.2 AV	54.0	-13.8	1.57 H	314	20.85	19.35

**ANTENNA POLARITY & TEST DISTANCE: VERTICAL AT 3 M**

NO.	FREQ. (MHz)	EMISSION LEVEL (dBuV/m)	LIMIT (dBuV/m)	MARGIN (dB)	ANTENNA HEIGHT (m)	TABLE ANGLE (Degree)	RAW VALUE (dBuV)	CORRECTION FACTOR (dB/m)
1	*5320.00	112.4 PK			1.48 V	186	103.67	8.73
2	*5320.00	102.4 AV			1.48 V	186	93.67	8.73
3	5350.00	57.9 PK	74.0	-16.1	1.48 V	186	49.10	8.80
4	5350.00	45.9 AV	54.0	-8.1	1.48 V	186	37.10	8.80
5	10640.00	50.5 PK	74.0	-23.5	1.69 V	200	35.92	14.58
6	10640.00	37.6 AV	54.0	-16.4	1.69 V	200	23.02	14.58
7	15960.00	51.4 PK	74.0	-22.6	1.49 V	159	32.05	19.35
8	15960.00	41.0 AV	54.0	-13.0	1.49 V	159	21.65	19.35

**REMARKS:**

1. Emission Level(dBuV/m) = Raw Value(dBuV) + Correction Factor(dB/m)
2. Correction Factor(dB/m) = Antenna Factor(dB/m) + Cable Factor(dB) – Pre-Amplifier Factor(dB)
3. The other emission levels were very low against the limit.
4. Margin value = Emission Level – Limit value
5. " \* ": Fundamental frequency.

<b>CHANNEL</b>	TX Channel 100	<b>DETECTOR FUNCTION</b>	Peak (PK)
<b>FREQUENCY RANGE</b>	1GHz ~ 40GHz		Average (AV)

**ANTENNA POLARITY & TEST DISTANCE: HORIZONTAL AT 3 M**

NO.	FREQ. (MHz)	EMISSION LEVEL (dBuV/m)	LIMIT (dBuV/m)	MARGIN (dB)	ANTENNA HEIGHT (m)	TABLE ANGLE (Degree)	RAW VALUE (dBuV)	CORRECTION FACTOR (dB/m)
1	#5470.00	56.2 PK	74.0	-17.8	2.00 H	209	47.02	9.18
2	#5470.00	43.2 AV	54.0	-10.8	2.00 H	209	34.02	9.18
3	*5500.00	108.0 PK			2.00 H	209	98.71	9.29
4	*5500.00	97.8 AV			2.00 H	209	88.51	9.29
5	11000.00	49.3 PK	74.0	-24.7	1.61 H	220	34.03	15.27
6	11000.00	36.8 AV	54.0	-17.2	1.61 H	220	21.53	15.27
7	#16500.00	51.6 PK	74.0	-22.4	1.53 H	323	30.73	20.87
8	#16500.00	40.5 AV	54.0	-13.5	1.53 H	323	19.63	20.87

**ANTENNA POLARITY & TEST DISTANCE: VERTICAL AT 3 M**

NO.	FREQ. (MHz)	EMISSION LEVEL (dBuV/m)	LIMIT (dBuV/m)	MARGIN (dB)	ANTENNA HEIGHT (m)	TABLE ANGLE (Degree)	RAW VALUE (dBuV)	CORRECTION FACTOR (dB/m)
1	#5470.00	60.4 PK	74.0	-13.6	1.51 V	185	51.22	9.18
2	#5470.00	47.3 AV	54.0	-6.7	1.51 V	185	38.12	9.18
3	*5500.00	111.6 PK			1.51 V	185	102.31	9.29
4	*5500.00	102.9 AV			1.51 V	185	93.61	9.29
5	11000.00	50.2 PK	74.0	-23.8	1.67 V	212	34.93	15.27
6	11000.00	37.1 AV	54.0	-16.9	1.67 V	212	21.83	15.27
7	#16500.00	51.3 PK	74.0	-22.7	1.56 V	167	30.43	20.87
8	#16500.00	41.0 AV	54.0	-13.0	1.56 V	167	20.13	20.87

**REMARKS:**

1. Emission Level(dBuV/m) = Raw Value(dBuV) + Correction Factor(dB/m)
2. Correction Factor(dB/m) = Antenna Factor(dB/m) + Cable Factor(dB) – Pre-Amplifier Factor(dB)
3. The other emission levels were very low against the limit.
4. Margin value = Emission Level – Limit value
5. " \* ": Fundamental frequency.
6. " # ": The radiated frequency is out of the restricted band.



<b>CHANNEL</b>	TX Channel 116	<b>DETECTOR FUNCTION</b>	Peak (PK)
<b>FREQUENCY RANGE</b>	1GHz ~ 40GHz		Average (AV)

**ANTENNA POLARITY & TEST DISTANCE: HORIZONTAL AT 3 M**

NO.	FREQ. (MHz)	EMISSION LEVEL (dBuV/m)	LIMIT (dBuV/m)	MARGIN (dB)	ANTENNA HEIGHT (m)	TABLE ANGLE (Degree)	RAW VALUE (dBuV)	CORRECTION FACTOR (dB/m)
1	#5470.00	53.7 PK	74.0	-20.3	2.08 H	199	44.52	9.18
2	#5470.00	42.6 AV	54.0	-11.4	2.08 H	199	33.42	9.18
3	*5580.00	107.0 PK			2.08 H	199	97.65	9.35
4	*5580.00	97.6 AV			2.08 H	199	88.25	9.35
5	#5725.00	52.2 PK	74.0	-21.8	2.08 H	199	42.50	9.70
6	#5725.00	39.1 AV	54.0	-14.9	2.08 H	199	29.40	9.70
7	11160.00	48.7 PK	74.0	-25.3	1.66 H	222	33.46	15.24
8	11160.00	36.2 AV	54.0	-17.8	1.66 H	222	20.96	15.24
9	#16740.00	51.1 PK	74.0	-22.9	1.49 H	316	29.33	21.77
10	#16740.00	40.6 AV	54.0	-13.4	1.49 H	316	18.83	21.77

**ANTENNA POLARITY & TEST DISTANCE: VERTICAL AT 3 M**

NO.	FREQ. (MHz)	EMISSION LEVEL (dBuV/m)	LIMIT (dBuV/m)	MARGIN (dB)	ANTENNA HEIGHT (m)	TABLE ANGLE (Degree)	RAW VALUE (dBuV)	CORRECTION FACTOR (dB/m)
1	#5470.00	57.6 PK	74.0	-16.4	1.63 V	165	48.42	9.18
2	#5470.00	45.6 AV	54.0	-8.4	1.63 V	165	36.42	9.18
3	*5580.00	112.6 PK			1.63 V	165	103.25	9.35
4	*5580.00	102.8 AV			1.63 V	165	93.45	9.35
5	#5725.00	54.6 PK	74.0	-19.4	1.63 V	165	44.90	9.70
6	#5725.00	42.8 AV	54.0	-11.2	1.63 V	165	33.10	9.70
7	11160.00	50.2 PK	74.0	-23.8	1.68 V	215	34.96	15.24
8	11160.00	37.2 AV	54.0	-16.8	1.68 V	215	21.96	15.24
9	#16740.00	51.4 PK	74.0	-22.6	1.51 V	184	29.63	21.77
10	#16740.00	41.3 AV	54.0	-12.7	1.51 V	184	19.53	21.77

**REMARKS:**

1. Emission Level(dBuV/m) = Raw Value(dBuV) + Correction Factor(dB/m)
2. Correction Factor(dB/m) = Antenna Factor(dB/m) + Cable Factor(dB) – Pre-Amplifier Factor(dB)
3. The other emission levels were very low against the limit.
4. Margin value = Emission Level – Limit value
5. " \* ": Fundamental frequency.
6. " # ": The radiated frequency is out of the restricted band.

<b>CHANNEL</b>	TX Channel 140	<b>DETECTOR FUNCTION</b>	Peak (PK)
<b>FREQUENCY RANGE</b>	1GHz ~ 40GHz		Average (AV)

**ANTENNA POLARITY & TEST DISTANCE: HORIZONTAL AT 3 M**

NO.	FREQ. (MHz)	EMISSION LEVEL (dBuV/m)	LIMIT (dBuV/m)	MARGIN (dB)	ANTENNA HEIGHT (m)	TABLE ANGLE (Degree)	RAW VALUE (dBuV)	CORRECTION FACTOR (dB/m)
1	*5700.00	107.9 PK			2.10 H	191	98.26	9.64
2	*5700.00	98.2 AV			2.10 H	191	88.56	9.64
3	#5725.00	59.2 PK	74.0	-14.8	2.10 H	191	49.50	9.70
4	#5725.00	46.7 AV	54.0	-7.3	2.10 H	191	37.00	9.70
5	11400.00	49.3 PK	74.0	-24.7	1.63 H	207	33.95	15.35
6	11400.00	36.5 AV	54.0	-17.5	1.63 H	207	21.15	15.35
7	#17100.00	51.6 PK	74.0	-22.4	1.57 H	311	27.80	23.80
8	#17100.00	40.6 AV	54.0	-13.4	1.57 H	311	16.80	23.80

**ANTENNA POLARITY & TEST DISTANCE: VERTICAL AT 3 M**

NO.	FREQ. (MHz)	EMISSION LEVEL (dBuV/m)	LIMIT (dBuV/m)	MARGIN (dB)	ANTENNA HEIGHT (m)	TABLE ANGLE (Degree)	RAW VALUE (dBuV)	CORRECTION FACTOR (dB/m)
1	*5700.00	113.5 PK			2.05 V	131	103.86	9.64
2	*5700.00	102.3 AV			2.05 V	131	92.66	9.64
3	#5725.00	63.1 PK	74.0	-10.9	2.05 V	131	53.40	9.70
4	#5725.00	50.5 AV	54.0	-3.5	2.05 V	131	40.80	9.70
5	11400.00	49.8 PK	74.0	-24.2	1.60 V	215	34.45	15.35
6	11400.00	37.0 AV	54.0	-17.0	1.60 V	215	21.65	15.35
7	#17100.00	51.1 PK	74.0	-22.9	1.56 V	171	27.30	23.80
8	#17100.00	40.5 AV	54.0	-13.5	1.56 V	171	16.70	23.80

**REMARKS:**

1. Emission Level(dBuV/m) = Raw Value(dBuV) + Correction Factor(dB/m)
2. Correction Factor(dB/m) = Antenna Factor(dB/m) + Cable Factor(dB) – Pre-Amplifier Factor(dB)
3. The other emission levels were very low against the limit.
4. Margin value = Emission Level – Limit value
5. " \* ": Fundamental frequency.
6. " # ": The radiated frequency is out of the restricted band.

**802.11ac (VHT20)**

<b>CHANNEL</b>	TX Channel 52	<b>DETECTOR FUNCTION</b>	Peak (PK)
<b>FREQUENCY RANGE</b>	1GHz ~ 40GHz		Average (AV)

**ANTENNA POLARITY & TEST DISTANCE: HORIZONTAL AT 3 M**

NO.	FREQ. (MHz)	EMISSION LEVEL (dBuV/m)	LIMIT (dBuV/m)	MARGIN (dB)	ANTENNA HEIGHT (m)	TABLE ANGLE (Degree)	RAW VALUE (dBuV)	CORRECTION FACTOR (dB/m)
1	5150.00	51.5 PK	74.0	-22.5	2.13 H	177	43.17	8.33
2	5150.00	38.6 AV	54.0	-15.4	2.13 H	177	30.27	8.33
3	*5260.00	108.2 PK			2.13 H	177	99.57	8.63
4	*5260.00	98.5 AV			2.13 H	177	89.87	8.63
5	5350.00	54.7 PK	74.0	-19.3	2.13 H	177	45.90	8.80
6	5350.00	41.6 AV	54.0	-12.4	2.13 H	177	32.80	8.80
7	#10520.00	48.5 PK	74.0	-25.5	1.65 H	200	34.04	14.46
8	#10520.00	36.2 AV	54.0	-17.8	1.65 H	200	21.74	14.46
9	15780.00	51.1 PK	74.0	-22.9	1.52 H	320	31.88	19.22
10	15780.00	40.4 AV	54.0	-13.6	1.52 H	320	21.18	19.22

**ANTENNA POLARITY & TEST DISTANCE: VERTICAL AT 3 M**

NO.	FREQ. (MHz)	EMISSION LEVEL (dBuV/m)	LIMIT (dBuV/m)	MARGIN (dB)	ANTENNA HEIGHT (m)	TABLE ANGLE (Degree)	RAW VALUE (dBuV)	CORRECTION FACTOR (dB/m)
1	5150.00	54.8 PK	74.0	-19.2	2.18 V	302	46.47	8.33
2	5150.00	41.8 AV	54.0	-12.2	2.18 V	302	33.47	8.33
3	*5260.00	113.6 PK			2.18 V	302	104.97	8.63
4	*5260.00	102.5 AV			2.18 V	302	93.87	8.63
5	5350.00	58.6 PK	74.0	-15.4	2.18 V	302	49.80	8.80
6	5350.00	45.4 AV	54.0	-8.6	2.18 V	302	36.60	8.80
7	#10520.00	49.9 PK	74.0	-24.1	1.65 V	204	35.44	14.46
8	#10520.00	37.1 AV	54.0	-16.9	1.65 V	204	22.64	14.46
9	15780.00	51.2 PK	74.0	-22.8	1.51 V	172	31.98	19.22
10	15780.00	40.9 AV	54.0	-13.1	1.51 V	172	21.68	19.22

**REMARKS:**

- Emission Level(dBuV/m) = Raw Value(dBuV) + Correction Factor(dB/m)
- Correction Factor(dB/m) = Antenna Factor(dB/m) + Cable Factor(dB) – Pre-Amplifier Factor(dB)
- The other emission levels were very low against the limit.
- Margin value = Emission Level – Limit value
- " \* ": Fundamental frequency.
- " # ": The radiated frequency is out of the restricted band.

<b>CHANNEL</b>	TX Channel 60	<b>DETECTOR FUNCTION</b>	Peak (PK)
<b>FREQUENCY RANGE</b>	1GHz ~ 40GHz		Average (AV)

**ANTENNA POLARITY & TEST DISTANCE: HORIZONTAL AT 3 M**

NO.	FREQ. (MHz)	EMISSION LEVEL (dBuV/m)	LIMIT (dBuV/m)	MARGIN (dB)	ANTENNA HEIGHT (m)	TABLE ANGLE (Degree)	RAW VALUE (dBuV)	CORRECTION FACTOR (dB/m)
1	*5300.00	107.8 PK			2.13 H	162	99.11	8.69
2	*5300.00	98.0 AV			2.13 H	162	89.31	8.69
3	5350.00	54.2 PK	74.0	-19.8	2.13 H	162	45.40	8.80
4	5350.00	41.4 AV	54.0	-12.6	2.13 H	162	32.60	8.80
5	10600.00	49.4 PK	74.0	-24.6	1.61 H	207	34.86	14.54
6	10600.00	36.7 AV	54.0	-17.3	1.61 H	207	22.16	14.54
7	15900.00	50.9 PK	74.0	-23.1	1.55 H	295	31.51	19.39
8	15900.00	40.2 AV	54.0	-13.8	1.55 H	295	20.81	19.39

**ANTENNA POLARITY & TEST DISTANCE: VERTICAL AT 3 M**

NO.	FREQ. (MHz)	EMISSION LEVEL (dBuV/m)	LIMIT (dBuV/m)	MARGIN (dB)	ANTENNA HEIGHT (m)	TABLE ANGLE (Degree)	RAW VALUE (dBuV)	CORRECTION FACTOR (dB/m)
1	*5300.00	113.4 PK			2.15 V	300	104.71	8.69
2	*5300.00	102.4 AV			2.15 V	300	93.71	8.69
3	5350.00	58.5 PK	74.0	-15.5	2.15 V	300	49.70	8.80
4	5350.00	45.6 AV	54.0	-8.4	2.15 V	300	36.80	8.80
5	10600.00	50.1 PK	74.0	-23.9	1.72 V	214	35.56	14.54
6	10600.00	37.0 AV	54.0	-17.0	1.72 V	214	22.46	14.54
7	15900.00	51.4 PK	74.0	-22.6	1.51 V	187	32.01	19.39
8	15900.00	41.2 AV	54.0	-12.8	1.51 V	187	21.81	19.39

**REMARKS:**

1. Emission Level(dBuV/m) = Raw Value(dBuV) + Correction Factor(dB/m)
2. Correction Factor(dB/m) = Antenna Factor(dB/m) + Cable Factor(dB) – Pre-Amplifier Factor(dB)
3. The other emission levels were very low against the limit.
4. Margin value = Emission Level – Limit value
5. " \* ": Fundamental frequency.

<b>CHANNEL</b>	TX Channel 64	<b>DETECTOR FUNCTION</b>	Peak (PK)
<b>FREQUENCY RANGE</b>	1GHz ~ 40GHz		Average (AV)

**ANTENNA POLARITY & TEST DISTANCE: HORIZONTAL AT 3 M**

NO.	FREQ. (MHz)	EMISSION LEVEL (dBuV/m)	LIMIT (dBuV/m)	MARGIN (dB)	ANTENNA HEIGHT (m)	TABLE ANGLE (Degree)	RAW VALUE (dBuV)	CORRECTION FACTOR (dB/m)
1	*5320.00	107.8 PK			2.08 H	161	99.07	8.73
2	*5320.00	97.9 AV			2.08 H	161	89.17	8.73
3	5350.00	57.4 PK	74.0	-16.6	2.08 H	161	48.60	8.80
4	5350.00	44.1 AV	54.0	-9.9	2.08 H	161	35.30	8.80
5	10640.00	48.9 PK	74.0	-25.1	1.71 H	205	34.32	14.58
6	10640.00	36.1 AV	54.0	-17.9	1.71 H	205	21.52	14.58
7	15960.00	51.2 PK	74.0	-22.8	1.51 H	307	31.85	19.35
8	15960.00	40.1 AV	54.0	-13.9	1.51 H	307	20.75	19.35

**ANTENNA POLARITY & TEST DISTANCE: VERTICAL AT 3 M**

NO.	FREQ. (MHz)	EMISSION LEVEL (dBuV/m)	LIMIT (dBuV/m)	MARGIN (dB)	ANTENNA HEIGHT (m)	TABLE ANGLE (Degree)	RAW VALUE (dBuV)	CORRECTION FACTOR (dB/m)
1	*5320.00	113.5 PK			2.18 V	298	104.77	8.73
2	*5320.00	102.4 AV			2.18 V	298	93.67	8.73
3	5350.00	61.3 PK	74.0	-12.7	2.18 V	298	52.50	8.80
4	5350.00	47.9 AV	54.0	-6.1	2.18 V	298	39.10	8.80
5	10640.00	50.4 PK	74.0	-23.6	1.71 V	219	35.82	14.58
6	10640.00	37.0 AV	54.0	-17.0	1.71 V	219	22.42	14.58
7	15960.00	51.4 PK	74.0	-22.6	1.55 V	160	32.05	19.35
8	15960.00	41.3 AV	54.0	-12.7	1.55 V	160	21.95	19.35

**REMARKS:**

1. Emission Level(dBuV/m) = Raw Value(dBuV) + Correction Factor(dB/m)
2. Correction Factor(dB/m) = Antenna Factor(dB/m) + Cable Factor(dB) – Pre-Amplifier Factor(dB)
3. The other emission levels were very low against the limit.
4. Margin value = Emission Level – Limit value
5. " \* ": Fundamental frequency.

<b>CHANNEL</b>	TX Channel 100	<b>DETECTOR FUNCTION</b>	Peak (PK)
<b>FREQUENCY RANGE</b>	1GHz ~ 40GHz		Average (AV)

**ANTENNA POLARITY & TEST DISTANCE: HORIZONTAL AT 3 M**

NO.	FREQ. (MHz)	EMISSION LEVEL (dBuV/m)	LIMIT (dBuV/m)	MARGIN (dB)	ANTENNA HEIGHT (m)	TABLE ANGLE (Degree)	RAW VALUE (dBuV)	CORRECTION FACTOR (dB/m)
1	#5470.00	59.7 PK	74.0	-14.3	2.08 H	152	50.52	9.18
2	#5470.00	44.4 AV	54.0	-9.6	2.08 H	152	35.22	9.18
3	*5500.00	108.1 PK			2.08 H	152	98.81	9.29
4	*5500.00	98.3 AV			2.08 H	152	89.01	9.29
5	11000.00	49.4 PK	74.0	-24.6	1.61 H	217	34.13	15.27
6	11000.00	36.8 AV	54.0	-17.2	1.61 H	217	21.53	15.27
7	#16500.00	50.9 PK	74.0	-23.1	1.50 H	301	30.03	20.87
8	#16500.00	40.2 AV	54.0	-13.8	1.50 H	301	19.33	20.87

**ANTENNA POLARITY & TEST DISTANCE: VERTICAL AT 3 M**

NO.	FREQ. (MHz)	EMISSION LEVEL (dBuV/m)	LIMIT (dBuV/m)	MARGIN (dB)	ANTENNA HEIGHT (m)	TABLE ANGLE (Degree)	RAW VALUE (dBuV)	CORRECTION FACTOR (dB/m)
1	#5470.00	63.8 PK	74.0	-10.2	2.45 V	325	54.62	9.18
2	#5470.00	48.6 AV	54.0	-5.4	2.45 V	325	39.42	9.18
3	*5500.00	113.9 PK			2.45 V	325	104.61	9.29
4	*5500.00	103.1 AV			2.45 V	325	93.81	9.29
5	11000.00	51.0 PK	74.0	-23.0	1.66 V	216	35.73	15.27
6	11000.00	37.6 AV	54.0	-16.4	1.66 V	216	22.33	15.27
7	#16500.00	51.1 PK	74.0	-22.9	1.56 V	156	30.23	20.87
8	#16500.00	40.9 AV	54.0	-13.1	1.56 V	156	20.03	20.87

**REMARKS:**

1. Emission Level(dBuV/m) = Raw Value(dBuV) + Correction Factor(dB/m)
2. Correction Factor(dB/m) = Antenna Factor(dB/m) + Cable Factor(dB) – Pre-Amplifier Factor(dB)
3. The other emission levels were very low against the limit.
4. Margin value = Emission Level – Limit value
5. " \* ": Fundamental frequency.
6. " # ": The radiated frequency is out of the restricted band.

<b>CHANNEL</b>	TX Channel 116	<b>DETECTOR FUNCTION</b>	Peak (PK)
<b>FREQUENCY RANGE</b>	1GHz ~ 40GHz		Average (AV)

**ANTENNA POLARITY & TEST DISTANCE: HORIZONTAL AT 3 M**

NO.	FREQ. (MHz)	EMISSION LEVEL (dBuV/m)	LIMIT (dBuV/m)	MARGIN (dB)	ANTENNA HEIGHT (m)	TABLE ANGLE (Degree)	RAW VALUE (dBuV)	CORRECTION FACTOR (dB/m)
1	#5470.00	55.9 PK	74.0	-18.1	2.10 H	149	46.72	9.18
2	#5470.00	43.0 AV	54.0	-11.0	2.10 H	149	33.82	9.18
3	*5580.00	108.9 PK			2.10 H	149	99.55	9.35
4	*5580.00	99.2 AV			2.10 H	149	89.85	9.35
5	11160.00	49.5 PK	74.0	-24.5	1.61 H	211	34.26	15.24
6	11160.00	36.8 AV	54.0	-17.2	1.61 H	211	21.56	15.24
7	#16740.00	50.8 PK	74.0	-23.2	1.60 H	305	29.03	21.77
8	#16740.00	40.2 AV	54.0	-13.8	1.60 H	305	18.43	21.77

**ANTENNA POLARITY & TEST DISTANCE: VERTICAL AT 3 M**

NO.	FREQ. (MHz)	EMISSION LEVEL (dBuV/m)	LIMIT (dBuV/m)	MARGIN (dB)	ANTENNA HEIGHT (m)	TABLE ANGLE (Degree)	RAW VALUE (dBuV)	CORRECTION FACTOR (dB/m)
1	#5470.00	60.1 PK	74.0	-13.9	2.46 V	322	50.92	9.18
2	#5470.00	47.1 AV	54.0	-6.9	2.46 V	322	37.92	9.18
3	*5580.00	114.6 PK			2.46 V	322	105.25	9.35
4	*5580.00	103.9 AV			2.46 V	322	94.55	9.35
5	11160.00	50.3 PK	74.0	-23.7	1.62 V	201	35.06	15.24
6	11160.00	37.1 AV	54.0	-16.9	1.62 V	201	21.86	15.24
7	#16740.00	50.5 PK	74.0	-23.5	1.50 V	164	28.73	21.77
8	#16740.00	40.4 AV	54.0	-13.6	1.50 V	164	18.63	21.77

**REMARKS:**

1. Emission Level(dBuV/m) = Raw Value(dBuV) + Correction Factor(dB/m)
2. Correction Factor(dB/m) = Antenna Factor(dB/m) + Cable Factor(dB) – Pre-Amplifier Factor(dB)
3. The other emission levels were very low against the limit.
4. Margin value = Emission Level – Limit value
5. " \* ": Fundamental frequency.
6. " # ": The radiated frequency is out of the restricted band.



<b>CHANNEL</b>	TX Channel 140	<b>DETECTOR FUNCTION</b>	Peak (PK)
<b>FREQUENCY RANGE</b>	1GHz ~ 40GHz		Average (AV)

**ANTENNA POLARITY & TEST DISTANCE: HORIZONTAL AT 3 M**

NO.	FREQ. (MHz)	EMISSION LEVEL (dBuV/m)	LIMIT (dBuV/m)	MARGIN (dB)	ANTENNA HEIGHT (m)	TABLE ANGLE (Degree)	RAW VALUE (dBuV)	CORRECTION FACTOR (dB/m)
1	*5700.00	109.0 PK			2.11 H	159	99.36	9.64
2	*5700.00	99.2 AV			2.11 H	159	89.56	9.64
3	#5725.00	65.4 PK	74.0	-8.6	2.11 H	159	55.70	9.70
4	#5725.00	48.5 AV	54.0	-5.5	2.11 H	159	38.80	9.70
5	11400.00	48.9 PK	74.0	-25.1	1.68 H	218	33.55	15.35
6	11400.00	36.3 AV	54.0	-17.7	1.68 H	218	20.95	15.35
7	#17100.00	50.9 PK	74.0	-23.1	1.51 H	294	27.10	23.80
8	#17100.00	40.1 AV	54.0	-13.9	1.51 H	294	16.30	23.80

**ANTENNA POLARITY & TEST DISTANCE: VERTICAL AT 3 M**

NO.	FREQ. (MHz)	EMISSION LEVEL (dBuV/m)	LIMIT (dBuV/m)	MARGIN (dB)	ANTENNA HEIGHT (m)	TABLE ANGLE (Degree)	RAW VALUE (dBuV)	CORRECTION FACTOR (dB/m)
1	*5700.00	114.8 PK			2.45 V	320	105.16	9.64
2	*5700.00	104.1 AV			2.45 V	320	94.46	9.64
3	#5725.00	69.6 PK	74.0	-4.4	2.45 V	320	59.90	9.70
4	#5725.00	52.7 AV	54.0	-1.3	2.45 V	320	43.00	9.70
5	11400.00	50.6 PK	74.0	-23.4	1.65 V	197	35.25	15.35
6	11400.00	37.3 AV	54.0	-16.7	1.65 V	197	21.95	15.35
7	#17100.00	50.8 PK	74.0	-23.2	1.50 V	170	27.00	23.80
8	#17100.00	40.7 AV	54.0	-13.3	1.50 V	170	16.90	23.80

**REMARKS:**

1. Emission Level(dBuV/m) = Raw Value(dBuV) + Correction Factor(dB/m)
2. Correction Factor(dB/m) = Antenna Factor(dB/m) + Cable Factor(dB) – Pre-Amplifier Factor(dB)
3. The other emission levels were very low against the limit.
4. Margin value = Emission Level – Limit value
5. " \* ": Fundamental frequency.
6. " # ": The radiated frequency is out of the restricted band.



**802.11ac (VHT40)**

<b>CHANNEL</b>	TX Channel 54	<b>DETECTOR FUNCTION</b>	Peak (PK)
<b>FREQUENCY RANGE</b>	1GHz ~ 40GHz		Average (AV)

**ANTENNA POLARITY & TEST DISTANCE: HORIZONTAL AT 3 M**

NO.	FREQ. (MHz)	EMISSION LEVEL (dBuV/m)	LIMIT (dBuV/m)	MARGIN (dB)	ANTENNA HEIGHT (m)	TABLE ANGLE (Degree)	RAW VALUE (dBuV)	CORRECTION FACTOR (dB/m)
1	5150.00	51.6 PK	74.0	-22.4	2.06 H	168	43.27	8.33
2	5150.00	38.2 AV	54.0	-15.8	2.06 H	168	29.87	8.33
3	*5270.00	104.8 PK			2.06 H	168	96.16	8.64
4	*5270.00	93.5 AV			2.06 H	168	84.86	8.64
5	5350.00	54.2 PK	74.0	-19.8	2.06 H	168	45.40	8.80
6	5350.00	41.2 AV	54.0	-12.8	2.06 H	168	32.40	8.80
7	#10540.00	49.1 PK	74.0	-24.9	1.62 H	195	34.63	14.47
8	#10540.00	36.5 AV	54.0	-17.5	1.62 H	195	22.03	14.47
9	15810.00	50.9 PK	74.0	-23.1	1.53 H	305	31.60	19.30
10	15810.00	39.9 AV	54.0	-14.1	1.53 H	305	20.60	19.30

**ANTENNA POLARITY & TEST DISTANCE: VERTICAL AT 3 M**

NO.	FREQ. (MHz)	EMISSION LEVEL (dBuV/m)	LIMIT (dBuV/m)	MARGIN (dB)	ANTENNA HEIGHT (m)	TABLE ANGLE (Degree)	RAW VALUE (dBuV)	CORRECTION FACTOR (dB/m)
1	5150.00	54.1 PK	74.0	-19.9	2.57 V	323	45.77	8.33
2	5150.00	40.8 AV	54.0	-13.2	2.57 V	323	32.47	8.33
3	*5270.00	110.6 PK			2.57 V	323	101.96	8.64
4	*5270.00	98.4 AV			2.57 V	323	89.76	8.64
5	5350.00	58.4 PK	74.0	-15.6	2.57 V	323	49.60	8.80
6	5350.00	45.5 AV	54.0	-8.5	2.57 V	323	36.70	8.80
7	#10540.00	50.6 PK	74.0	-23.4	1.68 V	218	36.13	14.47
8	#10540.00	37.5 AV	54.0	-16.5	1.68 V	218	23.03	14.47
9	15810.00	51.7 PK	74.0	-22.3	1.53 V	159	32.40	19.30
10	15810.00	41.2 AV	54.0	-12.8	1.53 V	159	21.90	19.30

**REMARKS:**

- Emission Level(dBuV/m) = Raw Value(dBuV) + Correction Factor(dB/m)
- Correction Factor(dB/m) = Antenna Factor(dB/m) + Cable Factor(dB) – Pre-Amplifier Factor(dB)
- The other emission levels were very low against the limit.
- Margin value = Emission Level – Limit value
- " \* ": Fundamental frequency.
- " # ": The radiated frequency is out of the restricted band.



<b>CHANNEL</b>	TX Channel 62	<b>DETECTOR FUNCTION</b>	Peak (PK)
<b>FREQUENCY RANGE</b>	1GHz ~ 40GHz		Average (AV)

**ANTENNA POLARITY & TEST DISTANCE: HORIZONTAL AT 3 M**

NO.	FREQ. (MHz)	EMISSION LEVEL (dBuV/m)	LIMIT (dBuV/m)	MARGIN (dB)	ANTENNA HEIGHT (m)	TABLE ANGLE (Degree)	RAW VALUE (dBuV)	CORRECTION FACTOR (dB/m)
1	*5310.00	104.8 PK			2.10 H	154	96.08	8.72
2	*5310.00	93.6 AV			2.10 H	154	84.88	8.72
3	5350.00	63.8 PK	74.0	-10.2	2.10 H	154	55.00	8.80
4	5350.00	48.2 AV	54.0	-5.8	2.10 H	154	39.40	8.80
5	10620.00	48.8 PK	74.0	-25.2	1.64 H	205	34.23	14.57
6	10620.00	36.3 AV	54.0	-17.7	1.64 H	205	21.73	14.57
7	15930.00	51.0 PK	74.0	-23.0	1.57 H	314	31.63	19.37
8	15930.00	40.1 AV	54.0	-13.9	1.57 H	314	20.73	19.37

**ANTENNA POLARITY & TEST DISTANCE: VERTICAL AT 3 M**

NO.	FREQ. (MHz)	EMISSION LEVEL (dBuV/m)	LIMIT (dBuV/m)	MARGIN (dB)	ANTENNA HEIGHT (m)	TABLE ANGLE (Degree)	RAW VALUE (dBuV)	CORRECTION FACTOR (dB/m)
1	*5310.00	110.6 PK			2.57 V	321	101.88	8.72
2	*5310.00	98.5 AV			2.57 V	321	89.78	8.72
3	5350.00	67.6 PK	74.0	-6.4	2.57 V	321	58.80	8.80
4	5350.00	52.3 AV	54.0	-1.7	2.57 V	321	43.50	8.80
5	10620.00	50.7 PK	74.0	-23.3	1.68 V	214	36.13	14.57
6	10620.00	37.5 AV	54.0	-16.5	1.68 V	214	22.93	14.57
7	15930.00	51.6 PK	74.0	-22.4	1.59 V	176	32.23	19.37
8	15930.00	41.1 AV	54.0	-12.9	1.59 V	176	21.73	19.37

**REMARKS:**

1. Emission Level(dBuV/m) = Raw Value(dBuV) + Correction Factor(dB/m)
2. Correction Factor(dB/m) = Antenna Factor(dB/m) + Cable Factor(dB) – Pre-Amplifier Factor(dB)
3. The other emission levels were very low against the limit.
4. Margin value = Emission Level – Limit value
5. " \* ": Fundamental frequency.

<b>CHANNEL</b>	TX Channel 102	<b>DETECTOR FUNCTION</b>	Peak (PK)
<b>FREQUENCY RANGE</b>	1GHz ~ 40GHz		Average (AV)

**ANTENNA POLARITY & TEST DISTANCE: HORIZONTAL AT 3 M**

NO.	FREQ. (MHz)	EMISSION LEVEL (dBuV/m)	LIMIT (dBuV/m)	MARGIN (dB)	ANTENNA HEIGHT (m)	TABLE ANGLE (Degree)	RAW VALUE (dBuV)	CORRECTION FACTOR (dB/m)
1	#5470.00	65.1 PK	74.0	-8.9	2.09 H	149	55.92	9.18
2	#5470.00	49.2 AV	54.0	-4.8	2.09 H	149	40.02	9.18
3	*5510.00	104.2 PK			2.09 H	149	94.91	9.29
4	*5510.00	93.0 AV			2.09 H	149	83.71	9.29
5	11020.00	48.5 PK	74.0	-25.5	1.70 H	212	33.23	15.27
6	11020.00	36.1 AV	54.0	-17.9	1.70 H	212	20.83	15.27
7	#16530.00	51.3 PK	74.0	-22.7	1.49 H	297	30.23	21.07
8	#16530.00	40.5 AV	54.0	-13.5	1.49 H	297	19.43	21.07

**ANTENNA POLARITY & TEST DISTANCE: VERTICAL AT 3 M**

NO.	FREQ. (MHz)	EMISSION LEVEL (dBuV/m)	LIMIT (dBuV/m)	MARGIN (dB)	ANTENNA HEIGHT (m)	TABLE ANGLE (Degree)	RAW VALUE (dBuV)	CORRECTION FACTOR (dB/m)
1	#5470.00	69.2 PK	74.0	-4.8	2.60 V	320	60.02	9.18
2	#5470.00	53.3 AV	54.0	-0.7	2.60 V	320	44.12	9.18
3	*5510.00	110.0 PK			2.60 V	320	100.71	9.29
4	*5510.00	97.9 AV			2.60 V	320	88.61	9.29
5	11020.00	50.6 PK	74.0	-23.4	1.63 V	195	35.33	15.27
6	11020.00	37.7 AV	54.0	-16.3	1.63 V	195	22.43	15.27
7	#16530.00	51.3 PK	74.0	-22.7	1.55 V	176	30.23	21.07
8	#16530.00	41.1 AV	54.0	-12.9	1.55 V	176	20.03	21.07

**REMARKS:**

1. Emission Level(dBuV/m) = Raw Value(dBuV) + Correction Factor(dB/m)
2. Correction Factor(dB/m) = Antenna Factor(dB/m) + Cable Factor(dB) – Pre-Amplifier Factor(dB)
3. The other emission levels were very low against the limit.
4. Margin value = Emission Level – Limit value
5. " \* ": Fundamental frequency.
6. " # ": The radiated frequency is out of the restricted band.

<b>CHANNEL</b>	TX Channel 110	<b>DETECTOR FUNCTION</b>	Peak (PK)
<b>FREQUENCY RANGE</b>	1GHz ~ 40GHz		Average (AV)

**ANTENNA POLARITY & TEST DISTANCE: HORIZONTAL AT 3 M**

NO.	FREQ. (MHz)	EMISSION LEVEL (dBuV/m)	LIMIT (dBuV/m)	MARGIN (dB)	ANTENNA HEIGHT (m)	TABLE ANGLE (Degree)	RAW VALUE (dBuV)	CORRECTION FACTOR (dB/m)
1	#5470.00	55.3 PK	74.0	-18.7	2.14 H	154	46.12	9.18
2	#5470.00	41.6 AV	54.0	-12.4	2.14 H	154	32.42	9.18
3	*5550.00	106.1 PK			2.14 H	154	96.77	9.33
4	*5550.00	95.2 AV			2.14 H	154	85.87	9.33
5	#5725.00	52.8 PK	74.0	-21.2	2.14 H	154	43.10	9.70
6	#5725.00	39.6 AV	54.0	-14.4	2.14 H	154	29.90	9.70
7	11100.00	49.5 PK	74.0	-24.5	1.62 H	196	34.25	15.25
8	11100.00	36.8 AV	54.0	-17.2	1.62 H	196	21.55	15.25
9	#16650.00	51.2 PK	74.0	-22.8	1.53 H	308	29.62	21.58
10	#16650.00	40.5 AV	54.0	-13.5	1.53 H	308	18.92	21.58

**ANTENNA POLARITY & TEST DISTANCE: VERTICAL AT 3 M**

NO.	FREQ. (MHz)	EMISSION LEVEL (dBuV/m)	LIMIT (dBuV/m)	MARGIN (dB)	ANTENNA HEIGHT (m)	TABLE ANGLE (Degree)	RAW VALUE (dBuV)	CORRECTION FACTOR (dB/m)
1	#5470.00	59.2 PK	74.0	-14.8	2.47 V	321	50.02	9.18
2	#5470.00	45.3 AV	54.0	-8.7	2.47 V	321	36.12	9.18
3	*5550.00	112.0 PK			2.47 V	321	102.67	9.33
4	*5550.00	100.0 AV			2.47 V	321	90.67	9.33
5	#5725.00	57.1 PK	74.0	-16.9	2.47 V	321	47.40	9.70
6	#5725.00	43.1 AV	54.0	-10.9	2.47 V	321	33.40	9.70
7	11100.00	50.7 PK	74.0	-23.3	1.65 V	207	35.45	15.25
8	11100.00	37.6 AV	54.0	-16.4	1.65 V	207	22.35	15.25
9	#16650.00	51.4 PK	74.0	-22.6	1.53 V	171	29.82	21.58
10	#16650.00	41.2 AV	54.0	-12.8	1.53 V	171	19.62	21.58

**REMARKS:**

1. Emission Level(dBuV/m) = Raw Value(dBuV) + Correction Factor(dB/m)
2. Correction Factor(dB/m) = Antenna Factor(dB/m) + Cable Factor(dB) – Pre-Amplifier Factor(dB)
3. The other emission levels were very low against the limit.
4. Margin value = Emission Level – Limit value
5. " \* ": Fundamental frequency.
6. " # ": The radiated frequency is out of the restricted band.



<b>CHANNEL</b>	TX Channel 134	<b>DETECTOR FUNCTION</b>	Peak (PK)
<b>FREQUENCY RANGE</b>	1GHz ~ 40GHz		Average (AV)

**ANTENNA POLARITY & TEST DISTANCE: HORIZONTAL AT 3 M**

NO.	FREQ. (MHz)	EMISSION LEVEL (dBuV/m)	LIMIT (dBuV/m)	MARGIN (dB)	ANTENNA HEIGHT (m)	TABLE ANGLE (Degree)	RAW VALUE (dBuV)	CORRECTION FACTOR (dB/m)
1	*5670.00	105.3 PK			2.18 H	152	95.75	9.55
2	*5670.00	94.4 AV			2.18 H	152	84.85	9.55
3	#5725.00	56.5 PK	74.0	-17.5	2.18 H	152	46.80	9.70
4	#5725.00	43.2 AV	54.0	-10.8	2.18 H	152	33.50	9.70
5	11340.00	48.7 PK	74.0	-25.3	1.65 H	217	33.46	15.24
6	11340.00	36.0 AV	54.0	-18.0	1.65 H	217	20.76	15.24
7	#17010.00	51.8 PK	74.0	-22.2	1.59 H	323	28.58	23.22
8	#17010.00	40.9 AV	54.0	-13.1	1.59 H	323	17.68	23.22

**ANTENNA POLARITY & TEST DISTANCE: VERTICAL AT 3 M**

NO.	FREQ. (MHz)	EMISSION LEVEL (dBuV/m)	LIMIT (dBuV/m)	MARGIN (dB)	ANTENNA HEIGHT (m)	TABLE ANGLE (Degree)	RAW VALUE (dBuV)	CORRECTION FACTOR (dB/m)
1	*5670.00	111.3 PK			2.50 V	320	101.75	9.55
2	*5670.00	99.2 AV			2.50 V	320	89.65	9.55
3	#5725.00	60.6 PK	74.0	-13.4	2.50 V	320	50.90	9.70
4	#5725.00	47.3 AV	54.0	-6.7	2.50 V	320	37.60	9.70
5	11340.00	50.2 PK	74.0	-23.8	1.65 V	200	34.96	15.24
6	11340.00	37.0 AV	54.0	-17.0	1.65 V	200	21.76	15.24
7	#17010.00	51.1 PK	74.0	-22.9	1.58 V	181	27.88	23.22
8	#17010.00	41.0 AV	54.0	-13.0	1.58 V	181	17.78	23.22

**REMARKS:**

1. Emission Level(dBuV/m) = Raw Value(dBuV) + Correction Factor(dB/m)
2. Correction Factor(dB/m) = Antenna Factor(dB/m) + Cable Factor(dB) – Pre-Amplifier Factor(dB)
3. The other emission levels were very low against the limit.
4. Margin value = Emission Level – Limit value
5. " \* ": Fundamental frequency.
6. " # ": The radiated frequency is out of the restricted band.

**802.11ac (VHT80)**

<b>CHANNEL</b>	TX Channel 58	<b>DETECTOR FUNCTION</b>	Peak (PK)
<b>FREQUENCY RANGE</b>	1GHz ~ 40GHz		Average (AV)

**ANTENNA POLARITY & TEST DISTANCE: HORIZONTAL AT 3 M**

NO.	FREQ. (MHz)	EMISSION LEVEL (dBuV/m)	LIMIT (dBuV/m)	MARGIN (dB)	ANTENNA HEIGHT (m)	TABLE ANGLE (Degree)	RAW VALUE (dBuV)	CORRECTION FACTOR (dB/m)
1	5150.00	51.4 PK	74.0	-22.6	2.09 H	166	43.07	8.33
2	5150.00	38.4 AV	54.0	-15.6	2.09 H	166	30.07	8.33
3	*5290.00	99.4 PK			2.09 H	166	90.72	8.68
4	*5290.00	87.3 AV			2.09 H	166	78.62	8.68
5	5350.00	63.5 PK	74.0	-10.5	2.09 H	166	54.70	8.80
6	5350.00	48.5 AV	54.0	-5.5	2.09 H	166	39.70	8.80
7	#10580.00	48.9 PK	74.0	-25.1	1.62 H	218	34.38	14.52
8	#10580.00	36.0 AV	54.0	-18.0	1.62 H	218	21.48	14.52
9	15870.00	51.2 PK	74.0	-22.8	1.55 H	301	31.85	19.35
10	15870.00	40.4 AV	54.0	-13.6	1.55 H	301	21.05	19.35

**ANTENNA POLARITY & TEST DISTANCE: VERTICAL AT 3 M**

NO.	FREQ. (MHz)	EMISSION LEVEL (dBuV/m)	LIMIT (dBuV/m)	MARGIN (dB)	ANTENNA HEIGHT (m)	TABLE ANGLE (Degree)	RAW VALUE (dBuV)	CORRECTION FACTOR (dB/m)
1	5150.00	52.4 PK	74.0	-21.6	1.65 V	337	44.07	8.33
2	5150.00	39.4 AV	54.0	-14.6	1.65 V	337	31.07	8.33
3	*5290.00	105.3 PK			1.65 V	337	96.62	8.68
4	*5290.00	92.0 AV			1.65 V	337	83.32	8.68
5	5350.00	67.7 PK	74.0	-6.3	1.65 V	337	58.90	8.80
6	5350.00	52.6 AV	54.0	-1.4	1.65 V	337	43.80	8.80
7	#10580.00	50.3 PK	74.0	-23.7	1.63 V	210	35.78	14.52
8	#10580.00	37.0 AV	54.0	-17.0	1.63 V	210	22.48	14.52
9	15870.00	52.0 PK	74.0	-22.0	1.50 V	163	32.65	19.35
10	15870.00	41.4 AV	54.0	-12.6	1.50 V	163	22.05	19.35

**REMARKS:**

- Emission Level(dBuV/m) = Raw Value(dBuV) + Correction Factor(dB/m)
- Correction Factor(dB/m) = Antenna Factor(dB/m) + Cable Factor(dB) – Pre-Amplifier Factor(dB)
- The other emission levels were very low against the limit.
- Margin value = Emission Level – Limit value
- " \* ": Fundamental frequency.
- " # ": The radiated frequency is out of the restricted band.

<b>CHANNEL</b>	TX Channel 106	<b>DETECTOR FUNCTION</b>	Peak (PK)
<b>FREQUENCY RANGE</b>	1GHz ~ 40GHz		Average (AV)

**ANTENNA POLARITY & TEST DISTANCE: HORIZONTAL AT 3 M**

NO.	FREQ. (MHz)	EMISSION LEVEL (dBuV/m)	LIMIT (dBuV/m)	MARGIN (dB)	ANTENNA HEIGHT (m)	TABLE ANGLE (Degree)	RAW VALUE (dBuV)	CORRECTION FACTOR (dB/m)
1	#5470.00	64.2 PK	74.0	-9.8	2.08 H	172	55.02	9.18
2	#5470.00	49.6 AV	54.0	-4.4	2.08 H	172	40.42	9.18
3	*5530.00	100.1 PK			2.08 H	172	90.79	9.31
4	*5530.00	87.2 AV			2.08 H	172	77.89	9.31
5	#5725.00	52.6 PK	74.0	-21.4	2.08 H	172	42.90	9.70
6	#5725.00	38.7 AV	54.0	-15.3	2.08 H	172	29.00	9.70
7	11060.00	49.1 PK	74.0	-24.9	1.61 H	206	33.84	15.26
8	11060.00	36.4 AV	54.0	-17.6	1.61 H	206	21.14	15.26
9	#16590.00	50.7 PK	74.0	-23.3	1.49 H	310	29.26	21.44
10	#16590.00	39.9 AV	54.0	-14.1	1.49 H	310	18.46	21.44

**ANTENNA POLARITY & TEST DISTANCE: VERTICAL AT 3 M**

NO.	FREQ. (MHz)	EMISSION LEVEL (dBuV/m)	LIMIT (dBuV/m)	MARGIN (dB)	ANTENNA HEIGHT (m)	TABLE ANGLE (Degree)	RAW VALUE (dBuV)	CORRECTION FACTOR (dB/m)
1	#5470.00	68.1 PK	74.0	-5.9	1.93 V	295	58.92	9.18
2	#5470.00	53.0 AV	54.0	-1.0	1.93 V	295	43.82	9.18
3	*5530.00	105.9 PK			1.93 V	295	96.59	9.31
4	*5530.00	91.8 AV			1.93 V	295	82.49	9.31
5	#5725.00	53.1 PK	74.0	-20.9	1.93 V	295	43.40	9.70
6	#5725.00	39.9 AV	54.0	-14.1	1.93 V	295	30.20	9.70
7	11060.00	50.9 PK	74.0	-23.1	1.61 V	195	35.64	15.26
8	11060.00	37.9 AV	54.0	-16.1	1.61 V	195	22.64	15.26
9	#16590.00	51.5 PK	74.0	-22.5	1.50 V	172	30.06	21.44
10	#16590.00	41.0 AV	54.0	-13.0	1.50 V	172	19.56	21.44

**REMARKS:**

1. Emission Level(dBuV/m) = Raw Value(dBuV) + Correction Factor(dB/m)
2. Correction Factor(dB/m) = Antenna Factor(dB/m) + Cable Factor(dB) – Pre-Amplifier Factor(dB)
3. The other emission levels were very low against the limit.
4. Margin value = Emission Level – Limit value
5. " \* ": Fundamental frequency.
6. " # ": The radiated frequency is out of the restricted band.



<b>CHANNEL</b>	TX Channel 122	<b>DETECTOR FUNCTION</b>	Peak (PK)
<b>FREQUENCY RANGE</b>	1GHz ~ 40GHz		Average (AV)

**ANTENNA POLARITY & TEST DISTANCE: HORIZONTAL AT 3 M**

NO.	FREQ. (MHz)	EMISSION LEVEL (dBuV/m)	LIMIT (dBuV/m)	MARGIN (dB)	ANTENNA HEIGHT (m)	TABLE ANGLE (Degree)	RAW VALUE (dBuV)	CORRECTION FACTOR (dB/m)
1	*5610.00	104.5 PK			1.98 H	169	95.11	9.39
2	*5610.00	91.6 AV			1.98 H	169	82.21	9.39
3	#5725.00	57.1 PK	74.0	-16.9	1.98 H	169	47.40	9.70
4	#5725.00	43.2 AV	54.0	-10.8	1.98 H	169	33.50	9.70
5	11220.00	49.4 PK	74.0	-24.6	1.63 H	218	34.18	15.22
6	11220.00	36.8 AV	54.0	-17.2	1.63 H	218	21.58	15.22
7	#16830.00	51.3 PK	74.0	-22.7	1.53 H	313	29.19	22.11
8	#16830.00	40.2 AV	54.0	-13.8	1.53 H	313	18.09	22.11

**ANTENNA POLARITY & TEST DISTANCE: VERTICAL AT 3 M**

NO.	FREQ. (MHz)	EMISSION LEVEL (dBuV/m)	LIMIT (dBuV/m)	MARGIN (dB)	ANTENNA HEIGHT (m)	TABLE ANGLE (Degree)	RAW VALUE (dBuV)	CORRECTION FACTOR (dB/m)
1	*5610.00	110.3 PK			2.04 V	294	100.91	9.39
2	*5610.00	96.2 AV			2.04 V	294	86.81	9.39
3	#5725.00	61.3 PK	74.0	-12.7	2.04 V	294	51.60	9.70
4	#5725.00	47.5 AV	54.0	-6.5	2.04 V	294	37.80	9.70
5	11220.00	50.7 PK	74.0	-23.3	1.71 V	192	35.48	15.22
6	11220.00	37.6 AV	54.0	-16.4	1.71 V	192	22.38	15.22
7	#16830.00	50.7 PK	74.0	-23.3	1.57 V	162	28.59	22.11
8	#16830.00	40.6 AV	54.0	-13.4	1.57 V	162	18.49	22.11

**REMARKS:**

1. Emission Level(dBuV/m) = Raw Value(dBuV) + Correction Factor(dB/m)
2. Correction Factor(dB/m) = Antenna Factor(dB/m) + Cable Factor(dB) – Pre-Amplifier Factor(dB)
3. The other emission levels were very low against the limit.
4. Margin value = Emission Level – Limit value
5. " \* ": Fundamental frequency.
6. " # ": The radiated frequency is out of the restricted band.



**4.1.8 Test Results (Mode 2 – Chain 1)**
**Above 1GHz Data:**
**802.11a**

<b>CHANNEL</b>	TX Channel 52	<b>DETECTOR FUNCTION</b>	Peak (PK)
<b>FREQUENCY RANGE</b>	1GHz ~ 40GHz		Average (AV)

**ANTENNA POLARITY & TEST DISTANCE: HORIZONTAL AT 3 M**

NO.	FREQ. (MHz)	EMISSION LEVEL (dBuV/m)	LIMIT (dBuV/m)	MARGIN (dB)	ANTENNA HEIGHT (m)	TABLE ANGLE (Degree)	RAW VALUE (dBuV)	CORRECTION FACTOR (dB/m)
1	5150.00	53.4 PK	74.0	-20.6	1.57 H	336	45.07	8.33
2	5150.00	39.8 AV	54.0	-14.2	1.57 H	336	31.47	8.33
3	*5260.00	107.1 PK			1.57 H	336	98.47	8.63
4	*5260.00	96.2 AV			1.57 H	336	87.57	8.63
5	5350.00	53.8 PK	74.0	-20.2	1.57 H	336	45.00	8.80
6	5350.00	40.1 AV	54.0	-13.9	1.57 H	336	31.30	8.80
7	#10520.00	49.0 PK	74.0	-25.0	1.65 H	206	34.54	14.46
8	#10520.00	36.2 AV	54.0	-17.8	1.65 H	206	21.74	14.46
9	15780.00	51.5 PK	74.0	-22.5	1.56 H	307	32.28	19.22
10	15780.00	40.5 AV	54.0	-13.5	1.56 H	307	21.28	19.22

**ANTENNA POLARITY & TEST DISTANCE: VERTICAL AT 3 M**

NO.	FREQ. (MHz)	EMISSION LEVEL (dBuV/m)	LIMIT (dBuV/m)	MARGIN (dB)	ANTENNA HEIGHT (m)	TABLE ANGLE (Degree)	RAW VALUE (dBuV)	CORRECTION FACTOR (dB/m)
1	5150.00	55.9 PK	74.0	-18.1	2.03 V	123	47.57	8.33
2	5150.00	42.4 AV	54.0	-11.6	2.03 V	123	34.07	8.33
3	*5260.00	114.9 PK			2.03 V	123	106.27	8.63
4	*5260.00	103.6 AV			2.03 V	123	94.97	8.63
5	5350.00	57.4 PK	74.0	-16.6	2.03 V	123	48.60	8.80
6	5350.00	44.3 AV	54.0	-9.7	2.03 V	123	35.50	8.80
7	#10520.00	49.6 PK	74.0	-24.4	1.60 V	194	35.14	14.46
8	#10520.00	36.6 AV	54.0	-17.4	1.60 V	194	22.14	14.46
9	15780.00	51.9 PK	74.0	-22.1	1.49 V	174	32.68	19.22
10	15780.00	41.0 AV	54.0	-13.0	1.49 V	174	21.78	19.22

**REMARKS:**

- Emission Level(dBuV/m) = Raw Value(dBuV) + Correction Factor(dB/m)
- Correction Factor(dB/m) = Antenna Factor(dB/m) + Cable Factor(dB) – Pre-Amplifier Factor(dB)
- The other emission levels were very low against the limit.
- Margin value = Emission Level – Limit value
- " \* ": Fundamental frequency.
- " # ": The radiated frequency is out of the restricted band.

<b>CHANNEL</b>	TX Channel 60	<b>DETECTOR FUNCTION</b>	Peak (PK)
<b>FREQUENCY RANGE</b>	1GHz ~ 40GHz		Average (AV)

**ANTENNA POLARITY & TEST DISTANCE: HORIZONTAL AT 3 M**

NO.	FREQ. (MHz)	EMISSION LEVEL (dBuV/m)	LIMIT (dBuV/m)	MARGIN (dB)	ANTENNA HEIGHT (m)	TABLE ANGLE (Degree)	RAW VALUE (dBuV)	CORRECTION FACTOR (dB/m)
1	*5300.00	107.6 PK			1.54 H	350	98.91	8.69
2	*5300.00	96.4 AV			1.54 H	350	87.71	8.69
3	5351.10	55.6 PK	74.0	-18.4	1.54 H	350	46.79	8.81
4	5351.10	42.2 AV	54.0	-11.8	1.54 H	350	33.39	8.81
5	10600.00	49.2 PK	74.0	-24.8	1.65 H	207	34.66	14.54
6	10600.00	36.7 AV	54.0	-17.3	1.65 H	207	22.16	14.54
7	15900.00	51.7 PK	74.0	-22.3	1.60 H	321	32.31	19.39
8	15900.00	40.5 AV	54.0	-13.5	1.60 H	321	21.11	19.39

**ANTENNA POLARITY & TEST DISTANCE: VERTICAL AT 3 M**

NO.	FREQ. (MHz)	EMISSION LEVEL (dBuV/m)	LIMIT (dBuV/m)	MARGIN (dB)	ANTENNA HEIGHT (m)	TABLE ANGLE (Degree)	RAW VALUE (dBuV)	CORRECTION FACTOR (dB/m)
1	*5300.00	114.9 PK			2.01 V	122	106.21	8.69
2	*5300.00	103.9 AV			2.01 V	122	95.21	8.69
3	5351.10	58.1 PK	74.0	-15.9	2.01 V	122	49.29	8.81
4	5351.10	44.8 AV	54.0	-9.2	2.01 V	122	35.99	8.81
5	10600.00	49.5 PK	74.0	-24.5	1.63 V	202	34.96	14.54
6	10600.00	36.6 AV	54.0	-17.4	1.63 V	202	22.06	14.54
7	15900.00	52.4 PK	74.0	-21.6	1.54 V	169	33.01	19.39
8	15900.00	41.4 AV	54.0	-12.6	1.54 V	169	22.01	19.39

**REMARKS:**

1. Emission Level(dBuV/m) = Raw Value(dBuV) + Correction Factor(dB/m)
2. Correction Factor(dB/m) = Antenna Factor(dB/m) + Cable Factor(dB) – Pre-Amplifier Factor(dB)
3. The other emission levels were very low against the limit.
4. Margin value = Emission Level – Limit value
5. " \* ": Fundamental frequency.

<b>CHANNEL</b>	TX Channel 64	<b>DETECTOR FUNCTION</b>	Peak (PK)
<b>FREQUENCY RANGE</b>	1GHz ~ 40GHz		Average (AV)

**ANTENNA POLARITY & TEST DISTANCE: HORIZONTAL AT 3 M**

NO.	FREQ. (MHz)	EMISSION LEVEL (dBuV/m)	LIMIT (dBuV/m)	MARGIN (dB)	ANTENNA HEIGHT (m)	TABLE ANGLE (Degree)	RAW VALUE (dBuV)	CORRECTION FACTOR (dB/m)
1	*5320.00	107.9 PK			1.58 H	340	99.17	8.73
2	*5320.00	96.7 AV			1.58 H	340	87.97	8.73
3	5350.00	60.1 PK	74.0	-13.9	1.58 H	340	51.30	8.80
4	5350.00	45.1 AV	54.0	-8.9	1.58 H	340	36.30	8.80
5	10640.00	48.8 PK	74.0	-25.2	1.69 H	208	34.22	14.58
6	10640.00	35.8 AV	54.0	-18.2	1.69 H	208	21.22	14.58
7	15960.00	51.8 PK	74.0	-22.2	1.61 H	294	32.45	19.35
8	15960.00	40.7 AV	54.0	-13.3	1.61 H	294	21.35	19.35

**ANTENNA POLARITY & TEST DISTANCE: VERTICAL AT 3 M**

NO.	FREQ. (MHz)	EMISSION LEVEL (dBuV/m)	LIMIT (dBuV/m)	MARGIN (dB)	ANTENNA HEIGHT (m)	TABLE ANGLE (Degree)	RAW VALUE (dBuV)	CORRECTION FACTOR (dB/m)
1	*5320.00	114.8 PK			1.89 V	121	106.07	8.73
2	*5320.00	103.9 AV			1.89 V	121	95.17	8.73
3	5350.00	62.5 PK	74.0	-11.5	1.89 V	121	53.70	8.80
4	5350.00	47.7 AV	54.0	-6.3	1.89 V	121	38.90	8.80
5	10640.00	49.6 PK	74.0	-24.4	1.60 V	186	35.02	14.58
6	10640.00	36.6 AV	54.0	-17.4	1.60 V	186	22.02	14.58
7	15960.00	51.7 PK	74.0	-22.3	1.55 V	187	32.35	19.35
8	15960.00	41.0 AV	54.0	-13.0	1.55 V	187	21.65	19.35

**REMARKS:**

1. Emission Level(dBuV/m) = Raw Value(dBuV) + Correction Factor(dB/m)
2. Correction Factor(dB/m) = Antenna Factor(dB/m) + Cable Factor(dB) – Pre-Amplifier Factor(dB)
3. The other emission levels were very low against the limit.
4. Margin value = Emission Level – Limit value
5. " \* ": Fundamental frequency.



<b>CHANNEL</b>	TX Channel 100	<b>DETECTOR FUNCTION</b>	Peak (PK)
<b>FREQUENCY RANGE</b>	1GHz ~ 40GHz		Average (AV)

**ANTENNA POLARITY & TEST DISTANCE: HORIZONTAL AT 3 M**

NO.	FREQ. (MHz)	EMISSION LEVEL (dBuV/m)	LIMIT (dBuV/m)	MARGIN (dB)	ANTENNA HEIGHT (m)	TABLE ANGLE (Degree)	RAW VALUE (dBuV)	CORRECTION FACTOR (dB/m)
1	#5470.00	62.3 PK	74.0	-11.7	1.55 H	354	53.12	9.18
2	#5470.00	47.1 AV	54.0	-6.9	1.55 H	354	37.92	9.18
3	*5500.00	109.8 PK			1.55 H	354	100.51	9.29
4	*5500.00	98.6 AV			1.55 H	354	89.31	9.29
5	11000.00	49.0 PK	74.0	-25.0	1.65 H	195	33.73	15.27
6	11000.00	36.1 AV	54.0	-17.9	1.65 H	195	20.83	15.27
7	#16500.00	51.3 PK	74.0	-22.7	1.60 H	313	30.43	20.87
8	#16500.00	40.4 AV	54.0	-13.6	1.60 H	313	19.53	20.87

**ANTENNA POLARITY & TEST DISTANCE: VERTICAL AT 3 M**

NO.	FREQ. (MHz)	EMISSION LEVEL (dBuV/m)	LIMIT (dBuV/m)	MARGIN (dB)	ANTENNA HEIGHT (m)	TABLE ANGLE (Degree)	RAW VALUE (dBuV)	CORRECTION FACTOR (dB/m)
1	#5470.00	65.2 PK	74.0	-8.8	1.90 V	116	56.02	9.18
2	#5470.00	49.7 AV	54.0	-4.3	1.90 V	116	40.52	9.18
3	*5500.00	116.8 PK			1.90 V	116	107.51	9.29
4	*5500.00	105.5 AV			1.90 V	116	96.21	9.29
5	11000.00	49.6 PK	74.0	-24.4	1.62 V	198	34.33	15.27
6	11000.00	36.6 AV	54.0	-17.4	1.62 V	198	21.33	15.27
7	#16500.00	51.3 PK	74.0	-22.7	1.52 V	163	30.43	20.87
8	#16500.00	40.7 AV	54.0	-13.3	1.52 V	163	19.83	20.87

**REMARKS:**

1. Emission Level(dBuV/m) = Raw Value(dBuV) + Correction Factor(dB/m)
2. Correction Factor(dB/m) = Antenna Factor(dB/m) + Cable Factor(dB) – Pre-Amplifier Factor(dB)
3. The other emission levels were very low against the limit.
4. Margin value = Emission Level – Limit value
5. " \* ": Fundamental frequency.
6. " # ": The radiated frequency is out of the restricted band.

<b>CHANNEL</b>	TX Channel 116	<b>DETECTOR FUNCTION</b>	Peak (PK)
<b>FREQUENCY RANGE</b>	1GHz ~ 40GHz		Average (AV)

**ANTENNA POLARITY & TEST DISTANCE: HORIZONTAL AT 3 M**

NO.	FREQ. (MHz)	EMISSION LEVEL (dBuV/m)	LIMIT (dBuV/m)	MARGIN (dB)	ANTENNA HEIGHT (m)	TABLE ANGLE (Degree)	RAW VALUE (dBuV)	CORRECTION FACTOR (dB/m)
1	#5470.00	55.2 PK	74.0	-18.8	1.60 H	332	46.02	9.18
2	#5470.00	43.5 AV	54.0	-10.5	1.60 H	332	34.32	9.18
3	*5580.00	109.0 PK			1.60 H	332	99.65	9.35
4	*5580.00	98.1 AV			1.60 H	332	88.75	9.35
5	#5725.00	53.7 PK	74.0	-20.3	1.60 H	332	44.00	9.70
6	#5725.00	41.2 AV	54.0	-12.8	1.60 H	332	31.50	9.70
7	11160.00	49.3 PK	74.0	-24.7	1.62 H	182	34.06	15.24
8	11160.00	36.5 AV	54.0	-17.5	1.62 H	182	21.26	15.24
9	#16740.00	51.5 PK	74.0	-22.5	1.61 H	326	29.73	21.77
10	#16740.00	40.8 AV	54.0	-13.2	1.61 H	326	19.03	21.77

**ANTENNA POLARITY & TEST DISTANCE: VERTICAL AT 3 M**

NO.	FREQ. (MHz)	EMISSION LEVEL (dBuV/m)	LIMIT (dBuV/m)	MARGIN (dB)	ANTENNA HEIGHT (m)	TABLE ANGLE (Degree)	RAW VALUE (dBuV)	CORRECTION FACTOR (dB/m)
1	#5470.00	58.1 PK	74.0	-15.9	1.97 V	115	48.92	9.18
2	#5470.00	45.2 AV	54.0	-8.8	1.97 V	115	36.02	9.18
3	*5580.00	116.0 PK			1.97 V	115	106.65	9.35
4	*5580.00	105.0 AV			1.97 V	115	95.65	9.35
5	#5725.00	56.6 PK	74.0	-17.4	1.97 V	115	46.90	9.70
6	#5725.00	43.8 AV	54.0	-10.2	1.97 V	115	34.10	9.70
7	11160.00	49.7 PK	74.0	-24.3	1.66 V	186	34.46	15.24
8	11160.00	36.6 AV	54.0	-17.4	1.66 V	186	21.36	15.24
9	#16740.00	51.4 PK	74.0	-22.6	1.45 V	173	29.63	21.77
10	#16740.00	40.6 AV	54.0	-13.4	1.45 V	173	18.83	21.77

**REMARKS:**

1. Emission Level(dBuV/m) = Raw Value(dBuV) + Correction Factor(dB/m)
2. Correction Factor(dB/m) = Antenna Factor(dB/m) + Cable Factor(dB) – Pre-Amplifier Factor(dB)
3. The other emission levels were very low against the limit.
4. Margin value = Emission Level – Limit value
5. " \* ": Fundamental frequency.
6. " # ": The radiated frequency is out of the restricted band.

<b>CHANNEL</b>	TX Channel 140	<b>DETECTOR FUNCTION</b>	Peak (PK)
<b>FREQUENCY RANGE</b>	1GHz ~ 40GHz		Average (AV)

**ANTENNA POLARITY & TEST DISTANCE: HORIZONTAL AT 3 M**

NO.	FREQ. (MHz)	EMISSION LEVEL (dBuV/m)	LIMIT (dBuV/m)	MARGIN (dB)	ANTENNA HEIGHT (m)	TABLE ANGLE (Degree)	RAW VALUE (dBuV)	CORRECTION FACTOR (dB/m)
1	*5700.00	109.6 PK			1.48 H	295	99.96	9.64
2	*5700.00	98.5 AV			1.48 H	295	88.86	9.64
3	#5725.00	63.4 PK	74.0	-10.6	1.48 H	295	53.70	9.70
4	#5725.00	48.2 AV	54.0	-5.8	1.48 H	295	38.50	9.70
5	11400.00	49.1 PK	74.0	-24.9	1.71 H	186	33.75	15.35
6	11400.00	36.5 AV	54.0	-17.5	1.71 H	186	21.15	15.35
7	#17100.00	51.3 PK	74.0	-22.7	1.59 H	299	27.50	23.80
8	#17100.00	40.1 AV	54.0	-13.9	1.59 H	299	16.30	23.80

**ANTENNA POLARITY & TEST DISTANCE: VERTICAL AT 3 M**

NO.	FREQ. (MHz)	EMISSION LEVEL (dBuV/m)	LIMIT (dBuV/m)	MARGIN (dB)	ANTENNA HEIGHT (m)	TABLE ANGLE (Degree)	RAW VALUE (dBuV)	CORRECTION FACTOR (dB/m)
1	*5700.00	116.6 PK			1.92 V	117	106.96	9.64
2	*5700.00	105.3 AV			1.92 V	117	95.66	9.64
3	#5725.00	65.6 PK	74.0	-8.4	1.92 V	117	55.90	9.70
4	#5725.00	50.6 AV	54.0	-3.4	1.92 V	117	40.90	9.70
5	11400.00	49.7 PK	74.0	-24.3	1.55 V	181	34.35	15.35
6	11400.00	36.7 AV	54.0	-17.3	1.55 V	181	21.35	15.35
7	#17100.00	51.5 PK	74.0	-22.5	1.54 V	181	27.70	23.80
8	#17100.00	40.8 AV	54.0	-13.2	1.54 V	181	17.00	23.80

**REMARKS:**

1. Emission Level(dBuV/m) = Raw Value(dBuV) + Correction Factor(dB/m)
2. Correction Factor(dB/m) = Antenna Factor(dB/m) + Cable Factor(dB) – Pre-Amplifier Factor(dB)
3. The other emission levels were very low against the limit.
4. Margin value = Emission Level – Limit value
5. " \* ": Fundamental frequency.
6. " # ": The radiated frequency is out of the restricted band.

**802.11ac (VHT20)**

<b>CHANNEL</b>	TX Channel 52	<b>DETECTOR FUNCTION</b>	Peak (PK)
<b>FREQUENCY RANGE</b>	1GHz ~ 40GHz		Average (AV)

**ANTENNA POLARITY & TEST DISTANCE: HORIZONTAL AT 3 M**

NO.	FREQ. (MHz)	EMISSION LEVEL (dBuV/m)	LIMIT (dBuV/m)	MARGIN (dB)	ANTENNA HEIGHT (m)	TABLE ANGLE (Degree)	RAW VALUE (dBuV)	CORRECTION FACTOR (dB/m)
1	5150.00	52.6 PK	74.0	-21.4	1.55 H	302	44.27	8.33
2	5150.00	38.4 AV	54.0	-15.6	1.55 H	302	30.07	8.33
3	*5260.00	107.7 PK			1.55 H	302	99.07	8.63
4	*5260.00	96.7 AV			1.55 H	302	88.07	8.63
5	5350.00	53.7 PK	74.0	-20.3	1.55 H	302	44.90	8.80
6	5350.00	39.6 AV	54.0	-14.4	1.55 H	302	30.80	8.80
7	#10520.00	49.0 PK	74.0	-25.0	1.67 H	204	34.54	14.46
8	#10520.00	36.1 AV	54.0	-17.9	1.67 H	204	21.64	14.46
9	15780.00	51.9 PK	74.0	-22.1	1.57 H	323	32.68	19.22
10	15780.00	40.8 AV	54.0	-13.2	1.57 H	323	21.58	19.22

**ANTENNA POLARITY & TEST DISTANCE: VERTICAL AT 3 M**

NO.	FREQ. (MHz)	EMISSION LEVEL (dBuV/m)	LIMIT (dBuV/m)	MARGIN (dB)	ANTENNA HEIGHT (m)	TABLE ANGLE (Degree)	RAW VALUE (dBuV)	CORRECTION FACTOR (dB/m)
1	5150.00	55.4 PK	74.0	-18.6	2.02 V	122	47.07	8.33
2	5150.00	40.6 AV	54.0	-13.4	2.02 V	122	32.27	8.33
3	*5260.00	114.6 PK			2.02 V	122	105.97	8.63
4	*5260.00	103.5 AV			2.02 V	122	94.87	8.63
5	5350.00	56.1 PK	74.0	-17.9	2.02 V	122	47.30	8.80
6	5350.00	42.3 AV	54.0	-11.7	2.02 V	122	33.50	8.80
7	#10520.00	49.9 PK	74.0	-24.1	1.63 V	183	35.44	14.46
8	#10520.00	36.9 AV	54.0	-17.1	1.63 V	183	22.44	14.46
9	15780.00	51.4 PK	74.0	-22.6	1.49 V	181	32.18	19.22
10	15780.00	40.7 AV	54.0	-13.3	1.49 V	181	21.48	19.22

**REMARKS:**

- Emission Level(dBuV/m) = Raw Value(dBuV) + Correction Factor(dB/m)
- Correction Factor(dB/m) = Antenna Factor(dB/m) + Cable Factor(dB) – Pre-Amplifier Factor(dB)
- The other emission levels were very low against the limit.
- Margin value = Emission Level – Limit value
- " \* ": Fundamental frequency.
- " # ": The radiated frequency is out of the restricted band.

<b>CHANNEL</b>	TX Channel 60	<b>DETECTOR FUNCTION</b>	Peak (PK)
<b>FREQUENCY RANGE</b>	1GHz ~ 40GHz		Average (AV)

**ANTENNA POLARITY & TEST DISTANCE: HORIZONTAL AT 3 M**

NO.	FREQ. (MHz)	EMISSION LEVEL (dBuV/m)	LIMIT (dBuV/m)	MARGIN (dB)	ANTENNA HEIGHT (m)	TABLE ANGLE (Degree)	RAW VALUE (dBuV)	CORRECTION FACTOR (dB/m)
1	*5300.00	107.9 PK			1.52 H	317	99.21	8.69
2	*5300.00	96.6 AV			1.52 H	317	87.91	8.69
3	5350.00	56.2 PK	74.0	-17.8	1.52 H	317	47.40	8.80
4	5350.00	42.1 AV	54.0	-11.9	1.52 H	317	33.30	8.80
5	10600.00	48.9 PK	74.0	-25.1	1.67 H	211	34.36	14.54
6	10600.00	35.9 AV	54.0	-18.1	1.67 H	211	21.36	14.54
7	15900.00	51.3 PK	74.0	-22.7	1.60 H	297	31.91	19.39
8	15900.00	40.4 AV	54.0	-13.6	1.60 H	297	21.01	19.39

**ANTENNA POLARITY & TEST DISTANCE: VERTICAL AT 3 M**

NO.	FREQ. (MHz)	EMISSION LEVEL (dBuV/m)	LIMIT (dBuV/m)	MARGIN (dB)	ANTENNA HEIGHT (m)	TABLE ANGLE (Degree)	RAW VALUE (dBuV)	CORRECTION FACTOR (dB/m)
1	*5300.00	114.6 PK			2.00 V	116	105.91	8.69
2	*5300.00	103.4 AV			2.00 V	116	94.71	8.69
3	5350.00	58.9 PK	74.0	-15.1	2.00 V	116	50.10	8.80
4	5350.00	44.5 AV	54.0	-9.5	2.00 V	116	35.70	8.80
5	10600.00	49.3 PK	74.0	-24.7	1.64 V	205	34.76	14.54
6	10600.00	36.3 AV	54.0	-17.7	1.64 V	205	21.76	14.54
7	15900.00	52.2 PK	74.0	-21.8	1.49 V	189	32.81	19.39
8	15900.00	41.3 AV	54.0	-12.7	1.49 V	189	21.91	19.39

**REMARKS:**

1. Emission Level(dBuV/m) = Raw Value(dBuV) + Correction Factor(dB/m)
2. Correction Factor(dB/m) = Antenna Factor(dB/m) + Cable Factor(dB) – Pre-Amplifier Factor(dB)
3. The other emission levels were very low against the limit.
4. Margin value = Emission Level – Limit value
5. " \* ": Fundamental frequency.



<b>CHANNEL</b>	TX Channel 64	<b>DETECTOR FUNCTION</b>	Peak (PK)
<b>FREQUENCY RANGE</b>	1GHz ~ 40GHz		Average (AV)

**ANTENNA POLARITY & TEST DISTANCE: HORIZONTAL AT 3 M**

NO.	FREQ. (MHz)	EMISSION LEVEL (dBuV/m)	LIMIT (dBuV/m)	MARGIN (dB)	ANTENNA HEIGHT (m)	TABLE ANGLE (Degree)	RAW VALUE (dBuV)	CORRECTION FACTOR (dB/m)
1	*5320.00	107.8 PK			1.48 H	303	99.07	8.73
2	*5320.00	96.6 AV			1.48 H	303	87.87	8.73
3	5350.00	60.6 PK	74.0	-13.4	1.48 H	303	51.80	8.80
4	5350.00	45.7 AV	54.0	-8.3	1.48 H	303	36.90	8.80
5	10640.00	48.8 PK	74.0	-25.2	1.60 H	202	34.22	14.58
6	10640.00	35.8 AV	54.0	-18.2	1.60 H	202	21.22	14.58
7	15960.00	51.8 PK	74.0	-22.2	1.61 H	308	32.45	19.35
8	15960.00	40.7 AV	54.0	-13.3	1.61 H	308	21.35	19.35

**ANTENNA POLARITY & TEST DISTANCE: VERTICAL AT 3 M**

NO.	FREQ. (MHz)	EMISSION LEVEL (dBuV/m)	LIMIT (dBuV/m)	MARGIN (dB)	ANTENNA HEIGHT (m)	TABLE ANGLE (Degree)	RAW VALUE (dBuV)	CORRECTION FACTOR (dB/m)
1	*5320.00	114.5 PK			2.07 V	120	105.77	8.73
2	*5320.00	103.3 AV			2.07 V	120	94.57	8.73
3	5350.00	63.0 PK	74.0	-11.0	2.07 V	120	54.20	8.80
4	5350.00	48.2 AV	54.0	-5.8	2.07 V	120	39.40	8.80
5	10640.00	49.9 PK	74.0	-24.1	1.57 V	179	35.32	14.58
6	10640.00	37.1 AV	54.0	-16.9	1.57 V	179	22.52	14.58
7	15960.00	52.0 PK	74.0	-22.0	1.49 V	162	32.65	19.35
8	15960.00	41.2 AV	54.0	-12.8	1.49 V	162	21.85	19.35

**REMARKS:**

1. Emission Level(dBuV/m) = Raw Value(dBuV) + Correction Factor(dB/m)
2. Correction Factor(dB/m) = Antenna Factor(dB/m) + Cable Factor(dB) – Pre-Amplifier Factor(dB)
3. The other emission levels were very low against the limit.
4. Margin value = Emission Level – Limit value
5. " \* ": Fundamental frequency.



<b>CHANNEL</b>	TX Channel 100	<b>DETECTOR FUNCTION</b>	Peak (PK)
<b>FREQUENCY RANGE</b>	1GHz ~ 40GHz		Average (AV)

**ANTENNA POLARITY & TEST DISTANCE: HORIZONTAL AT 3 M**

NO.	FREQ. (MHz)	EMISSION LEVEL (dBuV/m)	LIMIT (dBuV/m)	MARGIN (dB)	ANTENNA HEIGHT (m)	TABLE ANGLE (Degree)	RAW VALUE (dBuV)	CORRECTION FACTOR (dB/m)
1	#5470.00	61.6 PK	74.0	-12.4	1.61 H	334	52.42	9.18
2	#5470.00	48.2 AV	54.0	-5.8	1.61 H	334	39.02	9.18
3	*5500.00	108.8 PK			1.61 H	334	99.51	9.29
4	*5500.00	98.0 AV			1.61 H	334	88.71	9.29
5	11000.00	48.4 PK	74.0	-25.6	1.71 H	205	33.13	15.27
6	11000.00	35.7 AV	54.0	-18.3	1.71 H	205	20.43	15.27
7	#16500.00	51.0 PK	74.0	-23.0	1.61 H	310	30.13	20.87
8	#16500.00	40.0 AV	54.0	-14.0	1.61 H	310	19.13	20.87

**ANTENNA POLARITY & TEST DISTANCE: VERTICAL AT 3 M**

NO.	FREQ. (MHz)	EMISSION LEVEL (dBuV/m)	LIMIT (dBuV/m)	MARGIN (dB)	ANTENNA HEIGHT (m)	TABLE ANGLE (Degree)	RAW VALUE (dBuV)	CORRECTION FACTOR (dB/m)
1	#5470.00	64.8 PK	74.0	-9.2	2.04 V	112	55.62	9.18
2	#5470.00	50.9 AV	54.0	-3.1	2.04 V	112	41.72	9.18
3	*5500.00	116.2 PK			2.04 V	112	106.91	9.29
4	*5500.00	105.3 AV			2.04 V	112	96.01	9.29
5	11000.00	49.9 PK	74.0	-24.1	1.63 V	197	34.63	15.27
6	11000.00	37.0 AV	54.0	-17.0	1.63 V	197	21.73	15.27
7	#16500.00	51.5 PK	74.0	-22.5	1.43 V	182	30.63	20.87
8	#16500.00	40.9 AV	54.0	-13.1	1.43 V	182	20.03	20.87

**REMARKS:**

1. Emission Level(dBuV/m) = Raw Value(dBuV) + Correction Factor(dB/m)
2. Correction Factor(dB/m) = Antenna Factor(dB/m) + Cable Factor(dB) – Pre-Amplifier Factor(dB)
3. The other emission levels were very low against the limit.
4. Margin value = Emission Level – Limit value
5. " \* ": Fundamental frequency.
6. " # ": The radiated frequency is out of the restricted band.



<b>CHANNEL</b>	TX Channel 116	<b>DETECTOR FUNCTION</b>	Peak (PK)
<b>FREQUENCY RANGE</b>	1GHz ~ 40GHz		Average (AV)

**ANTENNA POLARITY & TEST DISTANCE: HORIZONTAL AT 3 M**

NO.	FREQ. (MHz)	EMISSION LEVEL (dBuV/m)	LIMIT (dBuV/m)	MARGIN (dB)	ANTENNA HEIGHT (m)	TABLE ANGLE (Degree)	RAW VALUE (dBuV)	CORRECTION FACTOR (dB/m)
1	#5470.00	56.8 PK	74.0	-17.2	1.57 H	319	47.62	9.18
2	#5470.00	42.3 AV	54.0	-11.7	1.57 H	319	33.12	9.18
3	*5580.00	109.2 PK			1.57 H	319	99.85	9.35
4	*5580.00	98.3 AV			1.57 H	319	88.95	9.35
5	11160.00	49.4 PK	74.0	-24.6	1.60 H	201	34.16	15.24
6	11160.00	36.3 AV	54.0	-17.7	1.60 H	201	21.06	15.24
7	#16740.00	50.9 PK	74.0	-23.1	1.59 H	316	29.13	21.77
8	#16740.00	40.2 AV	54.0	-13.8	1.59 H	316	18.43	21.77

**ANTENNA POLARITY & TEST DISTANCE: VERTICAL AT 3 M**

NO.	FREQ. (MHz)	EMISSION LEVEL (dBuV/m)	LIMIT (dBuV/m)	MARGIN (dB)	ANTENNA HEIGHT (m)	TABLE ANGLE (Degree)	RAW VALUE (dBuV)	CORRECTION FACTOR (dB/m)
1	#5470.00	59.2 PK	74.0	-14.8	2.03 V	111	50.02	9.18
2	#5470.00	44.9 AV	54.0	-9.1	2.03 V	111	35.72	9.18
3	*5580.00	116.7 PK			2.03 V	111	107.35	9.35
4	*5580.00	105.2 AV			2.03 V	111	95.85	9.35
5	11160.00	49.2 PK	74.0	-24.8	1.64 V	180	33.96	15.24
6	11160.00	36.4 AV	54.0	-17.6	1.64 V	180	21.16	15.24
7	#16740.00	52.0 PK	74.0	-22.0	1.50 V	185	30.23	21.77
8	#16740.00	41.2 AV	54.0	-12.8	1.50 V	185	19.43	21.77

**REMARKS:**

1. Emission Level(dBuV/m) = Raw Value(dBuV) + Correction Factor(dB/m)
2. Correction Factor(dB/m) = Antenna Factor(dB/m) + Cable Factor(dB) – Pre-Amplifier Factor(dB)
3. The other emission levels were very low against the limit.
4. Margin value = Emission Level – Limit value
5. " \* ": Fundamental frequency.
6. " # ": The radiated frequency is out of the restricted band.



<b>CHANNEL</b>	TX Channel 140	<b>DETECTOR FUNCTION</b>	Peak (PK)
<b>FREQUENCY RANGE</b>	1GHz ~ 40GHz		Average (AV)

**ANTENNA POLARITY & TEST DISTANCE: HORIZONTAL AT 3 M**

NO.	FREQ. (MHz)	EMISSION LEVEL (dBuV/m)	LIMIT (dBuV/m)	MARGIN (dB)	ANTENNA HEIGHT (m)	TABLE ANGLE (Degree)	RAW VALUE (dBuV)	CORRECTION FACTOR (dB/m)
1	*5700.00	109.4 PK			1.61 H	313	99.76	9.64
2	*5700.00	98.5 AV			1.61 H	313	88.86	9.64
3	#5725.00	66.7 PK	74.0	-7.3	1.61 H	313	57.00	9.70
4	#5725.00	51.3 AV	54.0	-2.7	1.61 H	313	41.60	9.70
5	11400.00	49.2 PK	74.0	-24.8	1.69 H	190	33.85	15.35
6	11400.00	36.4 AV	54.0	-17.6	1.69 H	190	21.05	15.35
7	#17100.00	51.0 PK	74.0	-23.0	1.56 H	313	27.20	23.80
8	#17100.00	40.1 AV	54.0	-13.9	1.56 H	313	16.30	23.80

**ANTENNA POLARITY & TEST DISTANCE: VERTICAL AT 3 M**

NO.	FREQ. (MHz)	EMISSION LEVEL (dBuV/m)	LIMIT (dBuV/m)	MARGIN (dB)	ANTENNA HEIGHT (m)	TABLE ANGLE (Degree)	RAW VALUE (dBuV)	CORRECTION FACTOR (dB/m)
1	*5700.00	116.8 PK			1.85 V	114	107.16	9.64
2	*5700.00	105.7 AV			1.85 V	114	96.06	9.64
3	#5725.00	68.2 PK	74.0	-5.8	1.85 V	114	58.50	9.70
4	#5725.00	53.5 AV	54.0	-0.5	1.85 V	114	43.80	9.70
5	11400.00	49.7 PK	74.0	-24.3	1.60 V	195	34.35	15.35
6	11400.00	36.6 AV	54.0	-17.4	1.60 V	195	21.25	15.35
7	#17100.00	51.8 PK	74.0	-22.2	1.48 V	182	28.00	23.80
8	#17100.00	41.1 AV	54.0	-12.9	1.48 V	182	17.30	23.80

**REMARKS:**

1. Emission Level(dBuV/m) = Raw Value(dBuV) + Correction Factor(dB/m)
2. Correction Factor(dB/m) = Antenna Factor(dB/m) + Cable Factor(dB) – Pre-Amplifier Factor(dB)
3. The other emission levels were very low against the limit.
4. Margin value = Emission Level – Limit value
5. " \* ": Fundamental frequency.
6. " # ": The radiated frequency is out of the restricted band.

**802.11ac (VHT40)**

<b>CHANNEL</b>	TX Channel 54	<b>DETECTOR FUNCTION</b>	Peak (PK)
<b>FREQUENCY RANGE</b>	1GHz ~ 40GHz		Average (AV)

**ANTENNA POLARITY & TEST DISTANCE: HORIZONTAL AT 3 M**

NO.	FREQ. (MHz)	EMISSION LEVEL (dBuV/m)	LIMIT (dBuV/m)	MARGIN (dB)	ANTENNA HEIGHT (m)	TABLE ANGLE (Degree)	RAW VALUE (dBuV)	CORRECTION FACTOR (dB/m)
1	5150.00	51.3 PK	74.0	-22.7	1.59 H	329	42.97	8.33
2	5150.00	38.4 AV	54.0	-15.6	1.59 H	329	30.07	8.33
3	*5270.00	104.3 PK			1.59 H	329	95.66	8.64
4	*5270.00	92.3 AV			1.59 H	329	83.66	8.64
5	5350.00	53.2 PK	74.0	-20.8	1.59 H	329	44.40	8.80
6	5350.00	40.3 AV	54.0	-13.7	1.59 H	329	31.50	8.80
7	#10540.00	48.5 PK	74.0	-25.5	1.62 H	208	34.03	14.47
8	#10540.00	35.8 AV	54.0	-18.2	1.62 H	208	21.33	14.47
9	15810.00	50.9 PK	74.0	-23.1	1.55 H	313	31.60	19.30
10	15810.00	40.1 AV	54.0	-13.9	1.55 H	313	20.80	19.30

**ANTENNA POLARITY & TEST DISTANCE: VERTICAL AT 3 M**

NO.	FREQ. (MHz)	EMISSION LEVEL (dBuV/m)	LIMIT (dBuV/m)	MARGIN (dB)	ANTENNA HEIGHT (m)	TABLE ANGLE (Degree)	RAW VALUE (dBuV)	CORRECTION FACTOR (dB/m)
1	5150.00	54.2 PK	74.0	-19.8	1.99 V	119	45.87	8.33
2	5150.00	40.9 AV	54.0	-13.1	1.99 V	119	32.57	8.33
3	*5270.00	111.8 PK			1.99 V	119	103.16	8.64
4	*5270.00	99.6 AV			1.99 V	119	90.96	8.64
5	5350.00	55.8 PK	74.0	-18.2	1.99 V	119	47.00	8.80
6	5350.00	42.9 AV	54.0	-11.1	1.99 V	119	34.10	8.80
7	#10540.00	50.1 PK	74.0	-23.9	1.58 V	184	35.63	14.47
8	#10540.00	36.9 AV	54.0	-17.1	1.58 V	184	22.43	14.47
9	15810.00	51.5 PK	74.0	-22.5	1.55 V	188	32.20	19.30
10	15810.00	40.8 AV	54.0	-13.2	1.55 V	188	21.50	19.30

**REMARKS:**

1. Emission Level(dBuV/m) = Raw Value(dBuV) + Correction Factor(dB/m)
2. Correction Factor(dB/m) = Antenna Factor(dB/m) + Cable Factor(dB) – Pre-Amplifier Factor(dB)
3. The other emission levels were very low against the limit.
4. Margin value = Emission Level – Limit value
5. " \* ": Fundamental frequency.
6. " # ": The radiated frequency is out of the restricted band.

<b>CHANNEL</b>	TX Channel 62	<b>DETECTOR FUNCTION</b>	Peak (PK)
<b>FREQUENCY RANGE</b>	1GHz ~ 40GHz		Average (AV)

**ANTENNA POLARITY & TEST DISTANCE: HORIZONTAL AT 3 M**

NO.	FREQ. (MHz)	EMISSION LEVEL (dBuV/m)	LIMIT (dBuV/m)	MARGIN (dB)	ANTENNA HEIGHT (m)	TABLE ANGLE (Degree)	RAW VALUE (dBuV)	CORRECTION FACTOR (dB/m)
1	*5310.00	104.9 PK			1.57 H	343	96.18	8.72
2	*5310.00	92.6 AV			1.57 H	343	83.88	8.72
3	5350.00	64.0 PK	74.0	-10.0	1.57 H	343	55.20	8.80
4	5350.00	48.6 AV	54.0	-5.4	1.57 H	343	39.80	8.80
5	10620.00	48.9 PK	74.0	-25.1	1.59 H	191	34.33	14.57
6	10620.00	36.1 AV	54.0	-17.9	1.59 H	191	21.53	14.57
7	15930.00	51.3 PK	74.0	-22.7	1.62 H	327	31.93	19.37
8	15930.00	40.4 AV	54.0	-13.6	1.62 H	327	21.03	19.37

**ANTENNA POLARITY & TEST DISTANCE: VERTICAL AT 3 M**

NO.	FREQ. (MHz)	EMISSION LEVEL (dBuV/m)	LIMIT (dBuV/m)	MARGIN (dB)	ANTENNA HEIGHT (m)	TABLE ANGLE (Degree)	RAW VALUE (dBuV)	CORRECTION FACTOR (dB/m)
1	*5310.00	111.6 PK			2.00 V	121	102.88	8.72
2	*5310.00	99.6 AV			2.00 V	121	90.88	8.72
3	5350.00	66.6 PK	74.0	-7.4	2.00 V	121	57.80	8.80
4	5350.00	51.0 AV	54.0	-3.0	2.00 V	121	42.20	8.80
5	10620.00	49.3 PK	74.0	-24.7	1.62 V	201	34.73	14.57
6	10620.00	36.2 AV	54.0	-17.8	1.62 V	201	21.63	14.57
7	15930.00	52.2 PK	74.0	-21.8	1.54 V	165	32.83	19.37
8	15930.00	41.1 AV	54.0	-12.9	1.54 V	165	21.73	19.37

**REMARKS:**

1. Emission Level(dBuV/m) = Raw Value(dBuV) + Correction Factor(dB/m)
2. Correction Factor(dB/m) = Antenna Factor(dB/m) + Cable Factor(dB) – Pre-Amplifier Factor(dB)
3. The other emission levels were very low against the limit.
4. Margin value = Emission Level – Limit value
5. " \* ": Fundamental frequency.

<b>CHANNEL</b>	TX Channel 102	<b>DETECTOR FUNCTION</b>	Peak (PK)
<b>FREQUENCY RANGE</b>	1GHz ~ 40GHz		Average (AV)

**ANTENNA POLARITY & TEST DISTANCE: HORIZONTAL AT 3 M**

NO.	FREQ. (MHz)	EMISSION LEVEL (dBuV/m)	LIMIT (dBuV/m)	MARGIN (dB)	ANTENNA HEIGHT (m)	TABLE ANGLE (Degree)	RAW VALUE (dBuV)	CORRECTION FACTOR (dB/m)
1	#5470.00	64.9 PK	74.0	-9.1	1.51 H	351	55.72	9.18
2	#5470.00	50.1 AV	54.0	-3.9	1.51 H	351	40.92	9.18
3	*5510.00	104.7 PK			1.51 H	351	95.41	9.29
4	*5510.00	92.5 AV			1.51 H	351	83.21	9.29
5	11020.00	48.6 PK	74.0	-25.4	1.60 H	200	33.33	15.27
6	11020.00	35.7 AV	54.0	-18.3	1.60 H	200	20.43	15.27
7	#16530.00	51.4 PK	74.0	-22.6	1.58 H	318	30.33	21.07
8	#16530.00	40.3 AV	54.0	-13.7	1.58 H	318	19.23	21.07

**ANTENNA POLARITY & TEST DISTANCE: VERTICAL AT 3 M**

NO.	FREQ. (MHz)	EMISSION LEVEL (dBuV/m)	LIMIT (dBuV/m)	MARGIN (dB)	ANTENNA HEIGHT (m)	TABLE ANGLE (Degree)	RAW VALUE (dBuV)	CORRECTION FACTOR (dB/m)
1	#5470.00	67.5 PK	74.0	-6.5	1.98 V	112	58.32	9.18
2	#5470.00	52.4 AV	54.0	-1.6	1.98 V	112	43.22	9.18
3	*5510.00	110.9 PK			1.98 V	112	101.61	9.29
4	*5510.00	98.9 AV			1.98 V	112	89.61	9.29
5	11020.00	49.7 PK	74.0	-24.3	1.62 V	190	34.43	15.27
6	11020.00	36.6 AV	54.0	-17.4	1.62 V	190	21.33	15.27
7	#16530.00	52.4 PK	74.0	-21.6	1.52 V	167	31.33	21.07
8	#16530.00	41.2 AV	54.0	-12.8	1.52 V	167	20.13	21.07

**REMARKS:**

1. Emission Level(dBuV/m) = Raw Value(dBuV) + Correction Factor(dB/m)
2. Correction Factor(dB/m) = Antenna Factor(dB/m) + Cable Factor(dB) – Pre-Amplifier Factor(dB)
3. The other emission levels were very low against the limit.
4. Margin value = Emission Level – Limit value
5. " \* ": Fundamental frequency.
6. " # ": The radiated frequency is out of the restricted band.

<b>CHANNEL</b>	TX Channel 110	<b>DETECTOR FUNCTION</b>	Peak (PK)
<b>FREQUENCY RANGE</b>	1GHz ~ 40GHz		Average (AV)

**ANTENNA POLARITY & TEST DISTANCE: HORIZONTAL AT 3 M**

NO.	FREQ. (MHz)	EMISSION LEVEL (dBuV/m)	LIMIT (dBuV/m)	MARGIN (dB)	ANTENNA HEIGHT (m)	TABLE ANGLE (Degree)	RAW VALUE (dBuV)	CORRECTION FACTOR (dB/m)
1	#5470.00	57.3 PK	74.0	-16.7	1.48 H	323	48.12	9.18
2	#5470.00	43.9 AV	54.0	-10.1	1.48 H	323	34.72	9.18
3	*5550.00	107.6 PK			1.48 H	323	98.27	9.33
4	*5550.00	95.2 AV			1.48 H	323	85.87	9.33
5	#5725.00	54.2 PK	74.0	-19.8	1.48 H	323	44.50	9.70
6	#5725.00	41.9 AV	54.0	-12.1	1.48 H	323	32.20	9.70
7	11100.00	49.3 PK	74.0	-24.7	1.64 H	188	34.05	15.25
8	11100.00	36.2 AV	54.0	-17.8	1.64 H	188	20.95	15.25
9	#16650.00	51.3 PK	74.0	-22.7	1.63 H	327	29.72	21.58
10	#16650.00	40.2 AV	54.0	-13.8	1.63 H	327	18.62	21.58

**ANTENNA POLARITY & TEST DISTANCE: VERTICAL AT 3 M**

NO.	FREQ. (MHz)	EMISSION LEVEL (dBuV/m)	LIMIT (dBuV/m)	MARGIN (dB)	ANTENNA HEIGHT (m)	TABLE ANGLE (Degree)	RAW VALUE (dBuV)	CORRECTION FACTOR (dB/m)
1	#5470.00	59.8 PK	74.0	-14.2	1.96 V	111	50.62	9.18
2	#5470.00	46.3 AV	54.0	-7.7	1.96 V	111	37.12	9.18
3	*5550.00	113.9 PK			1.96 V	111	104.57	9.33
4	*5550.00	101.4 AV			1.96 V	111	92.07	9.33
5	#5725.00	56.7 PK	74.0	-17.3	1.96 V	111	47.00	9.70
6	#5725.00	43.7 AV	54.0	-10.3	1.96 V	111	34.00	9.70
7	11100.00	50.0 PK	74.0	-24.0	1.58 V	208	34.75	15.25
8	11100.00	36.7 AV	54.0	-17.3	1.58 V	208	21.45	15.25
9	#16650.00	51.7 PK	74.0	-22.3	1.45 V	174	30.12	21.58
10	#16650.00	41.1 AV	54.0	-12.9	1.45 V	174	19.52	21.58

**REMARKS:**

1. Emission Level(dBuV/m) = Raw Value(dBuV) + Correction Factor(dB/m)
2. Correction Factor(dB/m) = Antenna Factor(dB/m) + Cable Factor(dB) – Pre-Amplifier Factor(dB)
3. The other emission levels were very low against the limit.
4. Margin value = Emission Level – Limit value
5. " \* ": Fundamental frequency.
6. " # ": The radiated frequency is out of the restricted band.





<b>CHANNEL</b>	TX Channel 134	<b>DETECTOR FUNCTION</b>	Peak (PK)
<b>FREQUENCY RANGE</b>	1GHz ~ 40GHz		Average (AV)

**ANTENNA POLARITY & TEST DISTANCE: HORIZONTAL AT 3 M**

NO.	FREQ. (MHz)	EMISSION LEVEL (dBuV/m)	LIMIT (dBuV/m)	MARGIN (dB)	ANTENNA HEIGHT (m)	TABLE ANGLE (Degree)	RAW VALUE (dBuV)	CORRECTION FACTOR (dB/m)
1	*5670.00	108.0 PK			1.54 H	308	98.45	9.55
2	*5670.00	95.6 AV			1.54 H	308	86.05	9.55
3	#5725.00	60.3 PK	74.0	-13.7	1.54 H	308	50.60	9.70
4	#5725.00	44.1 AV	54.0	-9.9	1.54 H	308	34.40	9.70
5	11340.00	49.4 PK	74.0	-24.6	1.60 H	187	34.16	15.24
6	11340.00	36.3 AV	54.0	-17.7	1.60 H	187	21.06	15.24
7	#17010.00	51.6 PK	74.0	-22.4	1.64 H	313	28.38	23.22
8	#17010.00	40.5 AV	54.0	-13.5	1.64 H	313	17.28	23.22

**ANTENNA POLARITY & TEST DISTANCE: VERTICAL AT 3 M**

NO.	FREQ. (MHz)	EMISSION LEVEL (dBuV/m)	LIMIT (dBuV/m)	MARGIN (dB)	ANTENNA HEIGHT (m)	TABLE ANGLE (Degree)	RAW VALUE (dBuV)	CORRECTION FACTOR (dB/m)
1	*5670.00	114.0 PK			1.90 V	110	104.45	9.55
2	*5670.00	102.3 AV			1.90 V	110	92.75	9.55
3	#5725.00	62.9 PK	74.0	-11.1	1.90 V	110	53.20	9.70
4	#5725.00	46.8 AV	54.0	-7.2	1.90 V	110	37.10	9.70
5	11340.00	49.7 PK	74.0	-24.3	1.59 V	189	34.46	15.24
6	11340.00	36.4 AV	54.0	-17.6	1.59 V	189	21.16	15.24
7	#17010.00	51.5 PK	74.0	-22.5	1.50 V	187	28.28	23.22
8	#17010.00	40.9 AV	54.0	-13.1	1.50 V	187	17.68	23.22

**REMARKS:**

1. Emission Level(dBuV/m) = Raw Value(dBuV) + Correction Factor(dB/m)
2. Correction Factor(dB/m) = Antenna Factor(dB/m) + Cable Factor(dB) – Pre-Amplifier Factor(dB)
3. The other emission levels were very low against the limit.
4. Margin value = Emission Level – Limit value
5. " \* ": Fundamental frequency.
6. " # ": The radiated frequency is out of the restricted band.

**802.11ac (VHT80)**

<b>CHANNEL</b>	TX Channel 58	<b>DETECTOR FUNCTION</b>	Peak (PK)
<b>FREQUENCY RANGE</b>	1GHz ~ 40GHz		Average (AV)

**ANTENNA POLARITY & TEST DISTANCE: HORIZONTAL AT 3 M**

NO.	FREQ. (MHz)	EMISSION LEVEL (dBuV/m)	LIMIT (dBuV/m)	MARGIN (dB)	ANTENNA HEIGHT (m)	TABLE ANGLE (Degree)	RAW VALUE (dBuV)	CORRECTION FACTOR (dB/m)
1	5150.00	51.2 PK	74.0	-22.8	1.62 H	287	42.87	8.33
2	5150.00	38.1 AV	54.0	-15.9	1.62 H	287	29.77	8.33
3	*5290.00	102.3 PK			1.62 H	287	93.62	8.68
4	*5290.00	87.3 AV			1.62 H	287	78.62	8.68
5	5350.00	65.9 PK	74.0	-8.1	1.62 H	287	57.10	8.80
6	5350.00	50.5 AV	54.0	-3.5	1.62 H	287	41.70	8.80
7	#10580.00	48.7 PK	74.0	-25.3	1.68 H	191	34.18	14.52
8	#10580.00	35.9 AV	54.0	-18.1	1.68 H	191	21.38	14.52
9	15870.00	51.7 PK	74.0	-22.3	1.54 H	304	32.35	19.35
10	15870.00	40.7 AV	54.0	-13.3	1.54 H	304	21.35	19.35

**ANTENNA POLARITY & TEST DISTANCE: VERTICAL AT 3 M**

NO.	FREQ. (MHz)	EMISSION LEVEL (dBuV/m)	LIMIT (dBuV/m)	MARGIN (dB)	ANTENNA HEIGHT (m)	TABLE ANGLE (Degree)	RAW VALUE (dBuV)	CORRECTION FACTOR (dB/m)
1	5150.00	53.6 PK	74.0	-20.4	1.90 V	118	45.27	8.33
2	5150.00	40.8 AV	54.0	-13.2	1.90 V	118	32.47	8.33
3	*5290.00	108.3 PK			1.90 V	118	99.62	8.68
4	*5290.00	93.9 AV			1.90 V	118	85.22	8.68
5	5350.00	68.5 PK	74.0	-5.5	1.90 V	118	59.70	8.80
6	5350.00	53.0 AV	54.0	-1.0	1.90 V	118	44.20	8.80
7	#10580.00	49.2 PK	74.0	-24.8	1.61 V	181	34.68	14.52
8	#10580.00	36.3 AV	54.0	-17.7	1.61 V	181	21.78	14.52
9	15870.00	51.6 PK	74.0	-22.4	1.48 V	158	32.25	19.35
10	15870.00	40.9 AV	54.0	-13.1	1.48 V	158	21.55	19.35

**REMARKS:**

- Emission Level(dBuV/m) = Raw Value(dBuV) + Correction Factor(dB/m)
- Correction Factor(dB/m) = Antenna Factor(dB/m) + Cable Factor(dB) – Pre-Amplifier Factor(dB)
- The other emission levels were very low against the limit.
- Margin value = Emission Level – Limit value
- " \* ": Fundamental frequency.
- " # ": The radiated frequency is out of the restricted band.

<b>CHANNEL</b>	TX Channel 106	<b>DETECTOR FUNCTION</b>	Peak (PK)
<b>FREQUENCY RANGE</b>	1GHz ~ 40GHz		Average (AV)

**ANTENNA POLARITY & TEST DISTANCE: HORIZONTAL AT 3 M**

NO.	FREQ. (MHz)	EMISSION LEVEL (dBuV/m)	LIMIT (dBuV/m)	MARGIN (dB)	ANTENNA HEIGHT (m)	TABLE ANGLE (Degree)	RAW VALUE (dBuV)	CORRECTION FACTOR (dB/m)
1	#5470.00	66.2 PK	74.0	-7.8	1.68 H	306	57.02	9.18
2	#5470.00	51.1 AV	54.0	-2.9	1.68 H	306	41.92	9.18
3	*5530.00	101.1 PK			1.68 H	306	91.79	9.31
4	*5530.00	86.6 AV			1.68 H	306	77.29	9.31
5	#5725.00	51.2 PK	74.0	-22.8	1.68 H	306	41.50	9.70
6	#5725.00	38.1 AV	54.0	-15.9	1.68 H	306	28.40	9.70
7	11060.00	49.0 PK	74.0	-25.0	1.70 H	181	33.74	15.26
8	11060.00	36.1 AV	54.0	-17.9	1.70 H	181	20.84	15.26
9	#16590.00	51.1 PK	74.0	-22.9	1.58 H	303	29.66	21.44
10	#16590.00	40.0 AV	54.0	-14.0	1.58 H	303	18.56	21.44

**ANTENNA POLARITY & TEST DISTANCE: VERTICAL AT 3 M**

NO.	FREQ. (MHz)	EMISSION LEVEL (dBuV/m)	LIMIT (dBuV/m)	MARGIN (dB)	ANTENNA HEIGHT (m)	TABLE ANGLE (Degree)	RAW VALUE (dBuV)	CORRECTION FACTOR (dB/m)
1	#5470.00	68.7 PK	74.0	-5.3	1.90 V	109	59.52	9.18
2	#5470.00	53.5 AV	54.0	-0.5	1.90 V	109	44.32	9.18
3	*5530.00	107.2 PK			1.90 V	109	97.89	9.31
4	*5530.00	93.3 AV			1.90 V	109	83.99	9.31
5	#5725.00	53.6 PK	74.0	-20.4	1.90 V	109	43.90	9.70
6	#5725.00	40.2 AV	54.0	-13.8	1.90 V	109	30.50	9.70
7	11060.00	49.1 PK	74.0	-24.9	1.65 V	179	33.84	15.26
8	11060.00	36.3 AV	54.0	-17.7	1.65 V	179	21.04	15.26
9	#16590.00	51.7 PK	74.0	-22.3	1.51 V	184	30.26	21.44
10	#16590.00	40.9 AV	54.0	-13.1	1.51 V	184	19.46	21.44

**REMARKS:**

1. Emission Level(dBuV/m) = Raw Value(dBuV) + Correction Factor(dB/m)
2. Correction Factor(dB/m) = Antenna Factor(dB/m) + Cable Factor(dB) – Pre-Amplifier Factor(dB)
3. The other emission levels were very low against the limit.
4. Margin value = Emission Level – Limit value
5. " \* ": Fundamental frequency.
6. " # ": The radiated frequency is out of the restricted band.



<b>CHANNEL</b>	TX Channel 122	<b>DETECTOR FUNCTION</b>	Peak (PK)
<b>FREQUENCY RANGE</b>	1GHz ~ 40GHz		Average (AV)

**ANTENNA POLARITY & TEST DISTANCE: HORIZONTAL AT 3 M**

NO.	FREQ. (MHz)	EMISSION LEVEL (dBuV/m)	LIMIT (dBuV/m)	MARGIN (dB)	ANTENNA HEIGHT (m)	TABLE ANGLE (Degree)	RAW VALUE (dBuV)	CORRECTION FACTOR (dB/m)
1	*5610.00	106.3 PK			1.59 H	298	96.91	9.39
2	*5610.00	91.2 AV			1.59 H	298	81.81	9.39
3	#5725.00	58.8 PK	74.0	-15.2	1.59 H	298	49.10	9.70
4	#5725.00	42.6 AV	54.0	-11.4	1.59 H	298	32.90	9.70
5	11220.00	48.5 PK	74.0	-25.5	1.69 H	194	33.28	15.22
6	11220.00	35.7 AV	54.0	-18.3	1.69 H	194	20.48	15.22
7	#16830.00	51.2 PK	74.0	-22.8	1.59 H	325	29.09	22.11
8	#16830.00	40.2 AV	54.0	-13.8	1.59 H	325	18.09	22.11

**ANTENNA POLARITY & TEST DISTANCE: VERTICAL AT 3 M**

NO.	FREQ. (MHz)	EMISSION LEVEL (dBuV/m)	LIMIT (dBuV/m)	MARGIN (dB)	ANTENNA HEIGHT (m)	TABLE ANGLE (Degree)	RAW VALUE (dBuV)	CORRECTION FACTOR (dB/m)
1	*5610.00	112.2 PK			1.93 V	112	102.81	9.39
2	*5610.00	97.8 AV			1.93 V	112	88.41	9.39
3	#5725.00	61.3 PK	74.0	-12.7	1.93 V	112	51.60	9.70
4	#5725.00	45.3 AV	54.0	-8.7	1.93 V	112	35.60	9.70
5	11220.00	49.4 PK	74.0	-24.6	1.65 V	181	34.18	15.22
6	11220.00	36.4 AV	54.0	-17.6	1.65 V	181	21.18	15.22
7	#16830.00	52.3 PK	74.0	-21.7	1.51 V	164	30.19	22.11
8	#16830.00	41.3 AV	54.0	-12.7	1.51 V	164	19.19	22.11

**REMARKS:**

1. Emission Level(dBuV/m) = Raw Value(dBuV) + Correction Factor(dB/m)
2. Correction Factor(dB/m) = Antenna Factor(dB/m) + Cable Factor(dB) – Pre-Amplifier Factor(dB)
3. The other emission levels were very low against the limit.
4. Margin value = Emission Level – Limit value
5. " \* ": Fundamental frequency.
6. " # ": The radiated frequency is out of the restricted band.

4.1.9 Test Results (Mode 3 – 2TX)

Above 1GHz Data:

802.11a

<b>CHANNEL</b>	TX Channel 52	<b>DETECTOR FUNCTION</b>	Peak (PK)
<b>FREQUENCY RANGE</b>	1GHz ~ 40GHz		Average (AV)

**ANTENNA POLARITY & TEST DISTANCE: HORIZONTAL AT 3 M**

NO.	FREQ. (MHz)	EMISSION LEVEL (dBuV/m)	LIMIT (dBuV/m)	MARGIN (dB)	ANTENNA HEIGHT (m)	TABLE ANGLE (Degree)	RAW VALUE (dBuV)	CORRECTION FACTOR (dB/m)
1	5150.00	57.6 PK	74.0	-16.4	1.62 H	195	49.27	8.33
2	5150.00	46.2 AV	54.0	-7.8	1.62 H	195	37.87	8.33
3	*5260.00	115.7 PK			1.62 H	195	107.07	8.63
4	*5260.00	105.2 AV			1.62 H	195	96.57	8.63
5	5350.00	60.1 PK	74.0	-13.9	1.62 H	195	51.30	8.80
6	5350.00	47.7 AV	54.0	-6.3	1.62 H	195	38.90	8.80
7	#10520.00	48.4 PK	74.0	-25.6	1.60 H	210	33.94	14.46
8	#10520.00	37.8 AV	54.0	-16.2	1.60 H	210	23.34	14.46
9	15780.00	51.3 PK	74.0	-22.7	1.56 H	312	32.08	19.22
10	15780.00	40.2 AV	54.0	-13.8	1.56 H	312	20.98	19.22

**ANTENNA POLARITY & TEST DISTANCE: VERTICAL AT 3 M**

NO.	FREQ. (MHz)	EMISSION LEVEL (dBuV/m)	LIMIT (dBuV/m)	MARGIN (dB)	ANTENNA HEIGHT (m)	TABLE ANGLE (Degree)	RAW VALUE (dBuV)	CORRECTION FACTOR (dB/m)
1	5150.00	60.2 PK	74.0	-13.8	1.02 V	322	51.87	8.33
2	5150.00	48.8 AV	54.0	-5.2	1.02 V	322	40.47	8.33
3	*5260.00	123.5 PK			1.02 V	322	114.87	8.63
4	*5260.00	112.6 AV			1.02 V	322	103.97	8.63
5	5350.00	62.8 PK	74.0	-11.2	1.02 V	322	54.00	8.80
6	5350.00	50.2 AV	54.0	-3.8	1.02 V	322	41.40	8.80
7	#10520.00	49.4 PK	74.0	-24.6	1.56 V	191	34.94	14.46
8	#10520.00	38.4 AV	54.0	-15.6	1.56 V	191	23.94	14.46
9	15780.00	52.1 PK	74.0	-21.9	1.54 V	169	32.88	19.22
10	15780.00	41.3 AV	54.0	-12.7	1.54 V	169	22.08	19.22

**REMARKS:**

1. Emission Level(dBuV/m) = Raw Value(dBuV) + Correction Factor(dB/m)
2. Correction Factor(dB/m) = Antenna Factor(dB/m) + Cable Factor(dB) – Pre-Amplifier Factor(dB)
3. The other emission levels were very low against the limit.
4. Margin value = Emission Level – Limit value
5. " \* ": Fundamental frequency.
6. " # ": The radiated frequency is out of the restricted band.

<b>CHANNEL</b>	TX Channel 60	<b>DETECTOR FUNCTION</b>	Peak (PK)
<b>FREQUENCY RANGE</b>	1GHz ~ 40GHz		Average (AV)

**ANTENNA POLARITY & TEST DISTANCE: HORIZONTAL AT 3 M**

NO.	FREQ. (MHz)	EMISSION LEVEL (dBuV/m)	LIMIT (dBuV/m)	MARGIN (dB)	ANTENNA HEIGHT (m)	TABLE ANGLE (Degree)	RAW VALUE (dBuV)	CORRECTION FACTOR (dB/m)
1	*5300.00	115.9 PK			1.65 H	196	107.21	8.69
2	*5300.00	105.5 AV			1.65 H	196	96.81	8.69
3	5351.10	62.5 PK	74.0	-11.5	1.65 H	196	53.69	8.81
4	5351.10	49.1 AV	54.0	-4.9	1.65 H	196	40.29	8.81
5	10600.00	48.7 PK	74.0	-25.3	1.65 H	207	34.16	14.54
6	10600.00	37.9 AV	54.0	-16.1	1.65 H	207	23.36	14.54
7	15900.00	57.4 PK	74.0	-16.6	1.53 H	303	38.01	19.39
8	15900.00	40.5 AV	54.0	-13.5	1.53 H	303	21.11	19.39

**ANTENNA POLARITY & TEST DISTANCE: VERTICAL AT 3 M**

NO.	FREQ. (MHz)	EMISSION LEVEL (dBuV/m)	LIMIT (dBuV/m)	MARGIN (dB)	ANTENNA HEIGHT (m)	TABLE ANGLE (Degree)	RAW VALUE (dBuV)	CORRECTION FACTOR (dB/m)
1	*5300.00	123.6 PK			1.01 V	322	114.91	8.69
2	*5300.00	112.4 AV			1.01 V	322	103.71	8.69
3	5351.10	65.1 PK	74.0	-8.9	1.01 V	322	56.29	8.81
4	5351.10	51.7 AV	54.0	-2.3	1.01 V	322	42.89	8.81
5	10600.00	49.4 PK	74.0	-24.6	1.60 V	196	34.86	14.54
6	10600.00	38.3 AV	54.0	-15.7	1.60 V	196	23.76	14.54
7	15900.00	58.3 PK	74.0	-15.7	1.52 V	172	38.91	19.39
8	15900.00	41.1 AV	54.0	-12.9	1.52 V	172	21.71	19.39

**REMARKS:**

1. Emission Level(dBuV/m) = Raw Value(dBuV) + Correction Factor(dB/m)
2. Correction Factor(dB/m) = Antenna Factor(dB/m) + Cable Factor(dB) – Pre-Amplifier Factor(dB)
3. The other emission levels were very low against the limit.
4. Margin value = Emission Level – Limit value
5. " \* ": Fundamental frequency.

<b>CHANNEL</b>	TX Channel 64	<b>DETECTOR FUNCTION</b>	Peak (PK)
<b>FREQUENCY RANGE</b>	1GHz ~ 40GHz		Average (AV)

**ANTENNA POLARITY & TEST DISTANCE: HORIZONTAL AT 3 M**

NO.	FREQ. (MHz)	EMISSION LEVEL (dBuV/m)	LIMIT (dBuV/m)	MARGIN (dB)	ANTENNA HEIGHT (m)	TABLE ANGLE (Degree)	RAW VALUE (dBuV)	CORRECTION FACTOR (dB/m)
1	*5320.00	112.8 PK			1.05 H	171	104.07	8.73
2	*5320.00	102.9 AV			1.05 H	171	94.17	8.73
3	5350.00	63.2 PK	74.0	-10.8	1.05 H	171	54.40	8.80
4	5350.00	50.9 AV	54.0	-3.1	1.05 H	171	42.10	8.80
5	10640.00	49.4 PK	74.0	-24.6	1.62 H	210	34.82	14.58
6	10640.00	37.6 AV	54.0	-16.4	1.62 H	210	23.02	14.58
7	15960.00	57.9 PK	74.0	-16.1	1.60 H	323	38.55	19.35
8	15960.00	40.2 AV	54.0	-13.8	1.60 H	323	20.85	19.35

**ANTENNA POLARITY & TEST DISTANCE: VERTICAL AT 3 M**

NO.	FREQ. (MHz)	EMISSION LEVEL (dBuV/m)	LIMIT (dBuV/m)	MARGIN (dB)	ANTENNA HEIGHT (m)	TABLE ANGLE (Degree)	RAW VALUE (dBuV)	CORRECTION FACTOR (dB/m)
1	*5320.00	120.5 PK			2.01 V	293	111.77	8.73
2	*5320.00	109.8 AV			2.01 V	293	101.07	8.73
3	5350.00	65.8 PK	74.0	-8.2	2.01 V	293	57.00	8.80
4	5350.00	53.3 AV	54.0	-0.7	2.01 V	293	44.50	8.80
5	10640.00	49.5 PK	74.0	-24.5	1.65 V	186	34.92	14.58
6	10640.00	38.2 AV	54.0	-15.8	1.65 V	186	23.62	14.58
7	15960.00	58.8 PK	74.0	-15.2	1.43 V	183	39.45	19.35
8	15960.00	40.8 AV	54.0	-13.2	1.43 V	183	21.45	19.35

**REMARKS:**

1. Emission Level(dBuV/m) = Raw Value(dBuV) + Correction Factor(dB/m)
2. Correction Factor(dB/m) = Antenna Factor(dB/m) + Cable Factor(dB) – Pre-Amplifier Factor(dB)
3. The other emission levels were very low against the limit.
4. Margin value = Emission Level – Limit value
5. " \* ": Fundamental frequency.

<b>CHANNEL</b>	TX Channel 100	<b>DETECTOR FUNCTION</b>	Peak (PK)
<b>FREQUENCY RANGE</b>	1GHz ~ 40GHz		Average (AV)

**ANTENNA POLARITY & TEST DISTANCE: HORIZONTAL AT 3 M**

NO.	FREQ. (MHz)	EMISSION LEVEL (dBuV/m)	LIMIT (dBuV/m)	MARGIN (dB)	ANTENNA HEIGHT (m)	TABLE ANGLE (Degree)	RAW VALUE (dBuV)	CORRECTION FACTOR (dB/m)
1	#5470.00	64.6 PK	74.0	-9.4	1.10 H	168	55.42	9.18
2	#5470.00	50.7 AV	54.0	-3.3	1.10 H	168	41.52	9.18
3	*5500.00	113.5 PK			1.10 H	168	104.21	9.29
4	*5500.00	103.2 AV			1.10 H	168	93.91	9.29
5	11000.00	49.5 PK	74.0	-24.5	1.62 H	190	34.23	15.27
6	11000.00	37.5 AV	54.0	-16.5	1.62 H	190	22.23	15.27
7	#16500.00	57.8 PK	74.0	-16.2	1.56 H	309	36.93	20.87
8	#16500.00	40.0 AV	54.0	-14.0	1.56 H	309	19.13	20.87

**ANTENNA POLARITY & TEST DISTANCE: VERTICAL AT 3 M**

NO.	FREQ. (MHz)	EMISSION LEVEL (dBuV/m)	LIMIT (dBuV/m)	MARGIN (dB)	ANTENNA HEIGHT (m)	TABLE ANGLE (Degree)	RAW VALUE (dBuV)	CORRECTION FACTOR (dB/m)
1	#5470.00	67.2 PK	74.0	-6.8	2.02 V	292	58.02	9.18
2	#5470.00	53.3 AV	54.0	-0.7	2.02 V	292	44.12	9.18
3	*5500.00	121.2 PK			2.02 V	292	111.91	9.29
4	*5500.00	109.9 AV			2.02 V	292	100.61	9.29
5	11000.00	49.9 PK	74.0	-24.1	1.58 V	196	34.63	15.27
6	11000.00	38.3 AV	54.0	-15.7	1.58 V	196	23.03	15.27
7	#16500.00	58.9 PK	74.0	-15.1	1.46 V	162	38.03	20.87
8	#16500.00	41.0 AV	54.0	-13.0	1.46 V	162	20.13	20.87

**REMARKS:**

1. Emission Level(dBuV/m) = Raw Value(dBuV) + Correction Factor(dB/m)
2. Correction Factor(dB/m) = Antenna Factor(dB/m) + Cable Factor(dB) – Pre-Amplifier Factor(dB)
3. The other emission levels were very low against the limit.
4. Margin value = Emission Level – Limit value
5. " \* ": Fundamental frequency.
6. " # ": The radiated frequency is out of the restricted band.



<b>CHANNEL</b>	TX Channel 116	<b>DETECTOR FUNCTION</b>	Peak (PK)
<b>FREQUENCY RANGE</b>	1GHz ~ 40GHz		Average (AV)

**ANTENNA POLARITY & TEST DISTANCE: HORIZONTAL AT 3 M**

NO.	FREQ. (MHz)	EMISSION LEVEL (dBuV/m)	LIMIT (dBuV/m)	MARGIN (dB)	ANTENNA HEIGHT (m)	TABLE ANGLE (Degree)	RAW VALUE (dBuV)	CORRECTION FACTOR (dB/m)
1	#5470.00	59.3 PK	74.0	-14.7	1.18 H	192	50.12	9.18
2	#5470.00	45.3 AV	54.0	-8.7	1.18 H	192	36.12	9.18
3	*5580.00	118.4 PK			1.18 H	192	109.05	9.35
4	*5580.00	107.5 AV			1.18 H	192	98.15	9.35
5	#5725.00	56.7 PK	74.0	-17.3	1.18 H	192	47.00	9.70
6	#5725.00	44.6 AV	54.0	-9.4	1.18 H	192	34.90	9.70
7	11160.00	48.5 PK	74.0	-25.5	1.68 H	206	33.26	15.24
8	11160.00	37.9 AV	54.0	-16.1	1.68 H	206	22.66	15.24
9	#16740.00	57.9 PK	74.0	-16.1	1.60 H	307	36.13	21.77
10	#16740.00	40.6 AV	54.0	-13.4	1.60 H	307	18.83	21.77

**ANTENNA POLARITY & TEST DISTANCE: VERTICAL AT 3 M**

NO.	FREQ. (MHz)	EMISSION LEVEL (dBuV/m)	LIMIT (dBuV/m)	MARGIN (dB)	ANTENNA HEIGHT (m)	TABLE ANGLE (Degree)	RAW VALUE (dBuV)	CORRECTION FACTOR (dB/m)
1	#5470.00	61.9 PK	74.0	-12.1	2.16 V	133	52.72	9.18
2	#5470.00	47.8 AV	54.0	-6.2	2.16 V	133	38.62	9.18
3	*5580.00	125.1 PK			2.16 V	133	115.75	9.35
4	*5580.00	114.2 AV			2.16 V	133	104.85	9.35
5	#5725.00	59.1 PK	74.0	-14.9	2.16 V	133	49.40	9.70
6	#5725.00	47.2 AV	54.0	-6.8	2.16 V	133	37.50	9.70
7	11160.00	49.2 PK	74.0	-24.8	1.65 V	188	33.96	15.24
8	11160.00	38.1 AV	54.0	-15.9	1.65 V	188	22.86	15.24
9	#16740.00	58.6 PK	74.0	-15.4	1.51 V	160	36.83	21.77
10	#16740.00	41.4 AV	54.0	-12.6	1.51 V	160	19.63	21.77

**REMARKS:**

1. Emission Level(dBuV/m) = Raw Value(dBuV) + Correction Factor(dB/m)
2. Correction Factor(dB/m) = Antenna Factor(dB/m) + Cable Factor(dB) – Pre-Amplifier Factor(dB)
3. The other emission levels were very low against the limit.
4. Margin value = Emission Level – Limit value
5. " \* ": Fundamental frequency.
6. " # ": The radiated frequency is out of the restricted band.



<b>CHANNEL</b>	TX Channel 140	<b>DETECTOR FUNCTION</b>	Peak (PK)
<b>FREQUENCY RANGE</b>	1GHz ~ 40GHz		Average (AV)

**ANTENNA POLARITY & TEST DISTANCE: HORIZONTAL AT 3 M**

NO.	FREQ. (MHz)	EMISSION LEVEL (dBuV/m)	LIMIT (dBuV/m)	MARGIN (dB)	ANTENNA HEIGHT (m)	TABLE ANGLE (Degree)	RAW VALUE (dBuV)	CORRECTION FACTOR (dB/m)
1	*5700.00	111.1 PK			1.22 H	175	101.46	9.64
2	*5700.00	101.4 AV			1.22 H	175	91.76	9.64
3	#5725.00	64.9 PK	68.2	-3.3	1.22 H	175	55.20	9.70
4	11400.00	48.9 PK	74.0	-25.1	1.67 H	200	33.55	15.35
5	11400.00	37.4 AV	54.0	-16.6	1.67 H	200	22.05	15.35
6	#17100.00	57.9 PK	68.2	-10.3	1.58 H	293	34.10	23.80

**ANTENNA POLARITY & TEST DISTANCE: VERTICAL AT 3 M**

NO.	FREQ. (MHz)	EMISSION LEVEL (dBuV/m)	LIMIT (dBuV/m)	MARGIN (dB)	ANTENNA HEIGHT (m)	TABLE ANGLE (Degree)	RAW VALUE (dBuV)	CORRECTION FACTOR (dB/m)
1	*5700.00	117.8 PK			2.06 V	135	108.16	9.64
2	*5700.00	108.4 AV			2.06 V	135	98.76	9.64
3	#5725.00	67.5 PK	68.2	-0.7	2.06 V	135	57.80	9.70
4	11400.00	49.4 PK	74.0	-24.6	1.57 V	196	34.05	15.35
5	11400.00	38.4 AV	54.0	-15.6	1.57 V	196	23.05	15.35
6	#17100.00	58.5 PK	68.2	-9.7	1.49 V	171	34.70	23.80

**REMARKS:**

1. Emission Level(dBuV/m) = Raw Value(dBuV) + Correction Factor(dB/m)
2. Correction Factor(dB/m) = Antenna Factor(dB/m) + Cable Factor(dB) – Pre-Amplifier Factor(dB)
3. The other emission levels were very low against the limit.
4. Margin value = Emission Level – Limit value
5. " \* ": Fundamental frequency.
6. " # ": The radiated frequency is out of the restricted band.

**802.11ac (VHT20)**

<b>CHANNEL</b>	TX Channel 52	<b>DETECTOR FUNCTION</b>	Peak (PK)
<b>FREQUENCY RANGE</b>	1GHz ~ 40GHz		Average (AV)

**ANTENNA POLARITY & TEST DISTANCE: HORIZONTAL AT 3 M**

NO.	FREQ. (MHz)	EMISSION LEVEL (dBuV/m)	LIMIT (dBuV/m)	MARGIN (dB)	ANTENNA HEIGHT (m)	TABLE ANGLE (Degree)	RAW VALUE (dBuV)	CORRECTION FACTOR (dB/m)
1	5150.00	54.9 PK	74.0	-19.1	1.19 H	183	46.57	8.33
2	5150.00	42.5 AV	54.0	-11.5	1.19 H	183	34.17	8.33
3	*5260.00	107.4 PK			1.19 H	183	98.77	8.63
4	*5260.00	97.0 AV			1.19 H	183	88.37	8.63
5	5350.00	57.2 PK	74.0	-16.8	1.19 H	183	48.40	8.80
6	5350.00	44.6 AV	54.0	-9.4	1.19 H	183	35.80	8.80
7	#10520.00	48.2 PK	74.0	-25.8	1.71 H	199	33.74	14.46
8	#10520.00	37.8 AV	54.0	-16.2	1.71 H	199	23.34	14.46
9	15780.00	57.9 PK	74.0	-16.1	1.51 H	317	38.68	19.22
10	15780.00	37.7 AV	54.0	-16.3	1.51 H	317	18.48	19.22

**ANTENNA POLARITY & TEST DISTANCE: VERTICAL AT 3 M**

NO.	FREQ. (MHz)	EMISSION LEVEL (dBuV/m)	LIMIT (dBuV/m)	MARGIN (dB)	ANTENNA HEIGHT (m)	TABLE ANGLE (Degree)	RAW VALUE (dBuV)	CORRECTION FACTOR (dB/m)
1	5150.00	57.6 PK	74.0	-16.4	2.06 V	82	49.27	8.33
2	5150.00	45.0 AV	54.0	-9.0	2.06 V	82	36.67	8.33
3	*5260.00	121.5 PK			2.06 V	82	112.87	8.63
4	*5260.00	112.8 AV			2.06 V	82	104.17	8.63
5	5350.00	59.9 PK	74.0	-14.1	2.06 V	82	51.10	8.80
6	5350.00	47.2 AV	54.0	-6.8	2.06 V	82	38.40	8.80
7	#10520.00	50.0 PK	74.0	-24.0	1.65 V	196	35.54	14.46
8	#10520.00	38.2 AV	54.0	-15.8	1.65 V	196	23.74	14.46
9	15780.00	58.3 PK	74.0	-15.7	1.44 V	166	39.08	19.22
10	15780.00	40.6 AV	54.0	-13.4	1.44 V	166	21.38	19.22

**REMARKS:**

- Emission Level(dBuV/m) = Raw Value(dBuV) + Correction Factor(dB/m)
- Correction Factor(dB/m) = Antenna Factor(dB/m) + Cable Factor(dB) – Pre-Amplifier Factor(dB)
- The other emission levels were very low against the limit.
- Margin value = Emission Level – Limit value
- " \* ": Fundamental frequency.
- " # ": The radiated frequency is out of the restricted band.

<b>CHANNEL</b>	TX Channel 60	<b>DETECTOR FUNCTION</b>	Peak (PK)
<b>FREQUENCY RANGE</b>	1GHz ~ 40GHz		Average (AV)

**ANTENNA POLARITY & TEST DISTANCE: HORIZONTAL AT 3 M**

NO.	FREQ. (MHz)	EMISSION LEVEL (dBuV/m)	LIMIT (dBuV/m)	MARGIN (dB)	ANTENNA HEIGHT (m)	TABLE ANGLE (Degree)	RAW VALUE (dBuV)	CORRECTION FACTOR (dB/m)
1	*5300.00	107.5 PK			1.22 H	194	98.81	8.69
2	*5300.00	96.9 AV			1.22 H	194	88.21	8.69
3	5350.00	67.1 PK	74.0	-6.9	1.22 H	194	58.30	8.80
4	5350.00	50.2 AV	54.0	-3.8	1.22 H	194	41.40	8.80
5	10600.00	49.7 PK	74.0	-24.3	1.64 H	210	35.16	14.54
6	10600.00	37.7 AV	54.0	-16.3	1.64 H	210	23.16	14.54
7	15900.00	57.4 PK	74.0	-16.6	1.61 H	309	38.01	19.39
8	15900.00	40.2 AV	54.0	-13.8	1.61 H	309	20.81	19.39

**ANTENNA POLARITY & TEST DISTANCE: VERTICAL AT 3 M**

NO.	FREQ. (MHz)	EMISSION LEVEL (dBuV/m)	LIMIT (dBuV/m)	MARGIN (dB)	ANTENNA HEIGHT (m)	TABLE ANGLE (Degree)	RAW VALUE (dBuV)	CORRECTION FACTOR (dB/m)
1	*5300.00	121.6 PK			2.09 V	82	112.91	8.69
2	*5300.00	112.6 AV			2.09 V	82	103.91	8.69
3	5350.00	69.7 PK	74.0	-4.3	2.09 V	82	60.90	8.80
4	5350.00	52.8 AV	54.0	-1.2	2.09 V	82	44.00	8.80
5	10600.00	50.2 PK	74.0	-23.8	1.60 V	190	35.66	14.54
6	10600.00	38.1 AV	54.0	-15.9	1.60 V	190	23.56	14.54
7	15900.00	58.3 PK	74.0	-15.7	1.47 V	177	38.91	19.39
8	15900.00	40.9 AV	54.0	-13.1	1.47 V	177	21.51	19.39

**REMARKS:**

1. Emission Level(dBuV/m) = Raw Value(dBuV) + Correction Factor(dB/m)
2. Correction Factor(dB/m) = Antenna Factor(dB/m) + Cable Factor(dB) – Pre-Amplifier Factor(dB)
3. The other emission levels were very low against the limit.
4. Margin value = Emission Level – Limit value
5. " \* ": Fundamental frequency.

<b>CHANNEL</b>	TX Channel 64	<b>DETECTOR FUNCTION</b>	Peak (PK)
<b>FREQUENCY RANGE</b>	1GHz ~ 40GHz		Average (AV)

**ANTENNA POLARITY & TEST DISTANCE: HORIZONTAL AT 3 M**

NO.	FREQ. (MHz)	EMISSION LEVEL (dBuV/m)	LIMIT (dBuV/m)	MARGIN (dB)	ANTENNA HEIGHT (m)	TABLE ANGLE (Degree)	RAW VALUE (dBuV)	CORRECTION FACTOR (dB/m)
1	*5320.00	103.2 PK			1.20 H	188	94.47	8.73
2	*5320.00	94.0 AV			1.20 H	188	85.27	8.73
3	5350.00	66.1 PK	74.0	-7.9	1.20 H	188	57.30	8.80
4	5350.00	51.0 AV	54.0	-3.0	1.20 H	188	42.20	8.80
5	10640.00	49.4 PK	74.0	-24.6	1.61 H	206	34.82	14.58
6	10640.00	37.6 AV	54.0	-16.4	1.61 H	206	23.02	14.58
7	15960.00	57.7 PK	74.0	-16.3	1.50 H	309	38.35	19.35
8	15960.00	41.0 AV	54.0	-13.0	1.50 H	309	21.65	19.35

**ANTENNA POLARITY & TEST DISTANCE: VERTICAL AT 3 M**

NO.	FREQ. (MHz)	EMISSION LEVEL (dBuV/m)	LIMIT (dBuV/m)	MARGIN (dB)	ANTENNA HEIGHT (m)	TABLE ANGLE (Degree)	RAW VALUE (dBuV)	CORRECTION FACTOR (dB/m)
1	*5320.00	117.3 PK			2.05 V	139	108.57	8.73
2	*5320.00	109.7 AV			2.05 V	139	100.97	8.73
3	5350.00	68.8 PK	74.0	-5.2	2.05 V	139	60.00	8.80
4	<b>5350.00</b>	<b>53.5 AV</b>	<b>54.0</b>	<b>-0.5</b>	<b>2.05 V</b>	<b>139</b>	<b>44.70</b>	<b>8.80</b>
5	10640.00	49.4 PK	74.0	-24.6	1.64 V	194	34.82	14.58
6	10640.00	38.3 AV	54.0	-15.7	1.64 V	194	23.72	14.58
7	15960.00	58.1 PK	74.0	-15.9	1.46 V	186	38.75	19.35
8	15960.00	41.2 AV	54.0	-12.8	1.46 V	186	21.85	19.35

**REMARKS:**

1. Emission Level(dBuV/m) = Raw Value(dBuV) + Correction Factor(dB/m)
2. Correction Factor(dB/m) = Antenna Factor(dB/m) + Cable Factor(dB) – Pre-Amplifier Factor(dB)
3. The other emission levels were very low against the limit.
4. Margin value = Emission Level – Limit value
5. " \* ": Fundamental frequency.



<b>CHANNEL</b>	TX Channel 100	<b>DETECTOR FUNCTION</b>	Peak (PK)
<b>FREQUENCY RANGE</b>	1GHz ~ 40GHz		Average (AV)

**ANTENNA POLARITY & TEST DISTANCE: HORIZONTAL AT 3 M**

NO.	FREQ. (MHz)	EMISSION LEVEL (dBuV/m)	LIMIT (dBuV/m)	MARGIN (dB)	ANTENNA HEIGHT (m)	TABLE ANGLE (Degree)	RAW VALUE (dBuV)	CORRECTION FACTOR (dB/m)
1	#5470.00	65.1 PK	74.0	-8.9	1.19 H	184	55.92	9.18
2	#5470.00	50.9 AV	54.0	-3.1	1.19 H	184	41.72	9.18
3	*5500.00	107.1 PK			1.19 H	184	97.81	9.29
4	*5500.00	96.5 AV			1.19 H	184	87.21	9.29
5	11000.00	48.8 PK	74.0	-25.2	1.60 H	216	33.53	15.27
6	11000.00	37.2 AV	54.0	-16.8	1.60 H	216	21.93	15.27
7	#16500.00	57.8 PK	74.0	-16.2	1.60 H	307	36.93	20.87
8	#16500.00	40.7 AV	54.0	-13.3	1.60 H	307	19.83	20.87

**ANTENNA POLARITY & TEST DISTANCE: VERTICAL AT 3 M**

NO.	FREQ. (MHz)	EMISSION LEVEL (dBuV/m)	LIMIT (dBuV/m)	MARGIN (dB)	ANTENNA HEIGHT (m)	TABLE ANGLE (Degree)	RAW VALUE (dBuV)	CORRECTION FACTOR (dB/m)
1	#5470.00	67.7 PK	74.0	-6.3	2.26 V	135	58.52	9.18
2	#5470.00	53.5 AV	54.0	-0.5	2.26 V	135	44.32	9.18
3	*5500.00	121.3 PK			2.26 V	135	112.01	9.29
4	*5500.00	111.1 AV			2.26 V	135	101.81	9.29
5	11000.00	49.0 PK	74.0	-25.0	1.61 V	182	33.73	15.27
6	11000.00	38.1 AV	54.0	-15.9	1.61 V	182	22.83	15.27
7	#16500.00	58.6 PK	74.0	-15.4	1.48 V	186	37.73	20.87
8	#16500.00	40.9 AV	54.0	-13.1	1.48 V	186	20.03	20.87

**REMARKS:**

1. Emission Level(dBuV/m) = Raw Value(dBuV) + Correction Factor(dB/m)
2. Correction Factor(dB/m) = Antenna Factor(dB/m) + Cable Factor(dB) – Pre-Amplifier Factor(dB)
3. The other emission levels were very low against the limit.
4. Margin value = Emission Level – Limit value
5. " \* ": Fundamental frequency.
6. " # ": The radiated frequency is out of the restricted band.

<b>CHANNEL</b>	TX Channel 116	<b>DETECTOR FUNCTION</b>	Peak (PK)
<b>FREQUENCY RANGE</b>	1GHz ~ 40GHz		Average (AV)

**ANTENNA POLARITY & TEST DISTANCE: HORIZONTAL AT 3 M**

NO.	FREQ. (MHz)	EMISSION LEVEL (dBuV/m)	LIMIT (dBuV/m)	MARGIN (dB)	ANTENNA HEIGHT (m)	TABLE ANGLE (Degree)	RAW VALUE (dBuV)	CORRECTION FACTOR (dB/m)
1	#5470.00	58.3 PK	74.0	-15.7	1.16 H	175	49.12	9.18
2	#5470.00	45.7 AV	54.0	-8.3	1.16 H	175	36.52	9.18
3	*5580.00	109.9 PK			1.16 H	175	100.55	9.35
4	*5580.00	99.7 AV			1.16 H	175	90.35	9.35
5	11160.00	49.3 PK	74.0	-24.7	1.63 H	216	34.06	15.24
6	11160.00	37.6 AV	54.0	-16.4	1.63 H	216	22.36	15.24
7	#16740.00	57.9 PK	74.0	-16.1	1.56 H	314	36.13	21.77
8	#16740.00	40.9 AV	54.0	-13.1	1.56 H	314	19.13	21.77

**ANTENNA POLARITY & TEST DISTANCE: VERTICAL AT 3 M**

NO.	FREQ. (MHz)	EMISSION LEVEL (dBuV/m)	LIMIT (dBuV/m)	MARGIN (dB)	ANTENNA HEIGHT (m)	TABLE ANGLE (Degree)	RAW VALUE (dBuV)	CORRECTION FACTOR (dB/m)
1	#5470.00	61.0 PK	74.0	-13.0	2.70 V	128	51.82	9.18
2	#5470.00	48.3 AV	54.0	-5.7	2.70 V	128	39.12	9.18
3	*5580.00	124.1 PK			2.70 V	128	114.75	9.35
4	*5580.00	114.3 AV			2.70 V	128	104.95	9.35
5	11160.00	49.5 PK	74.0	-24.5	1.54 V	208	34.26	15.24
6	11160.00	38.7 AV	54.0	-15.3	1.54 V	208	23.46	15.24
7	#16740.00	58.6 PK	74.0	-15.4	1.50 V	161	36.83	21.77
8	#16740.00	40.9 AV	54.0	-13.1	1.50 V	161	19.13	21.77

**REMARKS:**

1. Emission Level(dBuV/m) = Raw Value(dBuV) + Correction Factor(dB/m)
2. Correction Factor(dB/m) = Antenna Factor(dB/m) + Cable Factor(dB) – Pre-Amplifier Factor(dB)
3. The other emission levels were very low against the limit.
4. Margin value = Emission Level – Limit value
5. " \* ": Fundamental frequency.
6. " # ": The radiated frequency is out of the restricted band.

<b>CHANNEL</b>	TX Channel 140	<b>DETECTOR FUNCTION</b>	Peak (PK)
<b>FREQUENCY RANGE</b>	1GHz ~ 40GHz		Average (AV)

**ANTENNA POLARITY & TEST DISTANCE: HORIZONTAL AT 3 M**

NO.	FREQ. (MHz)	EMISSION LEVEL (dBuV/m)	LIMIT (dBuV/m)	MARGIN (dB)	ANTENNA HEIGHT (m)	TABLE ANGLE (Degree)	RAW VALUE (dBuV)	CORRECTION FACTOR (dB/m)
1	*5700.00	103.3 PK			1.14 H	174	93.66	9.64
2	*5700.00	94.4 AV			1.14 H	174	84.76	9.64
3	#5725.00	64.8 PK	68.2	-3.4	1.14 H	174	55.10	9.70
4	11400.00	49.3 PK	74.0	-24.7	1.60 H	217	33.95	15.35
5	11400.00	37.6 AV	54.0	-16.4	1.60 H	217	22.25	15.35
6	#17100.00	57.9 PK	68.2	-10.3	1.57 H	296	34.10	23.80

**ANTENNA POLARITY & TEST DISTANCE: VERTICAL AT 3 M**

NO.	FREQ. (MHz)	EMISSION LEVEL (dBuV/m)	LIMIT (dBuV/m)	MARGIN (dB)	ANTENNA HEIGHT (m)	TABLE ANGLE (Degree)	RAW VALUE (dBuV)	CORRECTION FACTOR (dB/m)
1	*5700.00	117.5 PK			2.10 V	135	107.86	9.64
2	*5700.00	108.8 AV			2.10 V	135	99.16	9.64
3	#5725.00	67.5 PK	68.2	-0.7	2.10 V	135	57.80	9.70
4	11400.00	49.0 PK	74.0	-25.0	1.62 V	186	33.65	15.35
5	11400.00	38.3 AV	54.0	-15.7	1.62 V	186	22.95	15.35
6	#17100.00	58.6 PK	68.2	-9.6	1.55 V	166	34.80	23.80

**REMARKS:**

1. Emission Level(dBuV/m) = Raw Value(dBuV) + Correction Factor(dB/m)
2. Correction Factor(dB/m) = Antenna Factor(dB/m) + Cable Factor(dB) – Pre-Amplifier Factor(dB)
3. The other emission levels were very low against the limit.
4. Margin value = Emission Level – Limit value
5. " \* ": Fundamental frequency.
6. " # ": The radiated frequency is out of the restricted band.



**802.11ac (VHT40)**

<b>CHANNEL</b>	TX Channel 54	<b>DETECTOR FUNCTION</b>	Peak (PK)
<b>FREQUENCY RANGE</b>	1GHz ~ 40GHz		Average (AV)

**ANTENNA POLARITY & TEST DISTANCE: HORIZONTAL AT 3 M**

NO.	FREQ. (MHz)	EMISSION LEVEL (dBuV/m)	LIMIT (dBuV/m)	MARGIN (dB)	ANTENNA HEIGHT (m)	TABLE ANGLE (Degree)	RAW VALUE (dBuV)	CORRECTION FACTOR (dB/m)
1	5150.00	51.4 PK	74.0	-22.6	1.16 H	181	43.07	8.33
2	5150.00	39.9 AV	54.0	-14.1	1.16 H	181	31.57	8.33
3	*5270.00	104.8 PK			1.16 H	181	96.16	8.64
4	*5270.00	93.5 AV			1.16 H	181	84.86	8.64
5	5350.00	61.5 PK	74.0	-12.5	1.16 H	181	52.70	8.80
6	5350.00	50.9 AV	54.0	-3.1	1.16 H	181	42.10	8.80
7	#10540.00	48.7 PK	74.0	-25.3	1.70 H	211	34.23	14.47
8	#10540.00	37.8 AV	54.0	-16.2	1.70 H	211	23.33	14.47
9	15810.00	57.6 PK	74.0	-16.4	1.56 H	314	38.30	19.30
10	15810.00	42.7 AV	54.0	-11.3	1.56 H	314	23.40	19.30

**ANTENNA POLARITY & TEST DISTANCE: VERTICAL AT 3 M**

NO.	FREQ. (MHz)	EMISSION LEVEL (dBuV/m)	LIMIT (dBuV/m)	MARGIN (dB)	ANTENNA HEIGHT (m)	TABLE ANGLE (Degree)	RAW VALUE (dBuV)	CORRECTION FACTOR (dB/m)
1	5150.00	54.1 PK	74.0	-19.9	2.20 V	78	45.77	8.33
2	5150.00	42.4 AV	54.0	-11.6	2.20 V	78	34.07	8.33
3	*5270.00	119.0 PK			2.20 V	78	110.36	8.64
4	*5270.00	107.9 AV			2.20 V	78	99.26	8.64
5	5350.00	64.1 PK	74.0	-9.9	2.20 V	78	55.30	8.80
<b>6</b>	<b>5350.00</b>	<b>53.5 AV</b>	<b>54.0</b>	<b>-0.5</b>	<b>2.20 V</b>	<b>78</b>	<b>44.70</b>	<b>8.80</b>
7	#10540.00	49.3 PK	74.0	-24.7	1.62 V	183	34.83	14.47
8	#10540.00	38.5 AV	54.0	-15.5	1.62 V	183	24.03	14.47
9	15810.00	58.7 PK	74.0	-15.3	1.46 V	168	39.40	19.30
10	15810.00	42.4 AV	54.0	-11.6	1.46 V	168	23.10	19.30

**REMARKS:**

- Emission Level(dBuV/m) = Raw Value(dBuV) + Correction Factor(dB/m)
- Correction Factor(dB/m) = Antenna Factor(dB/m) + Cable Factor(dB) – Pre-Amplifier Factor(dB)
- The other emission levels were very low against the limit.
- Margin value = Emission Level – Limit value
- " \* ": Fundamental frequency.
- " # ": The radiated frequency is out of the restricted band.



<b>CHANNEL</b>	TX Channel 62	<b>DETECTOR FUNCTION</b>	Peak (PK)
<b>FREQUENCY RANGE</b>	1GHz ~ 40GHz		Average (AV)

**ANTENNA POLARITY & TEST DISTANCE: HORIZONTAL AT 3 M**

NO.	FREQ. (MHz)	EMISSION LEVEL (dBuV/m)	LIMIT (dBuV/m)	MARGIN (dB)	ANTENNA HEIGHT (m)	TABLE ANGLE (Degree)	RAW VALUE (dBuV)	CORRECTION FACTOR (dB/m)
1	*5310.00	103.1 PK			1.21 H	177	94.38	8.72
2	*5310.00	92.0 AV			1.21 H	177	83.28	8.72
3	5350.00	61.8 PK	74.0	-12.2	1.21 H	177	53.00	8.80
4	5350.00	50.8 AV	54.0	-3.2	1.21 H	177	42.00	8.80
5	10620.00	48.4 PK	74.0	-25.6	1.69 H	192	33.83	14.57
6	10620.00	37.7 AV	54.0	-16.3	1.69 H	192	23.13	14.57
7	15930.00	57.4 PK	74.0	-16.6	1.51 H	298	38.03	19.37
8	15930.00	42.1 AV	54.0	-11.9	1.51 H	298	22.73	19.37

**ANTENNA POLARITY & TEST DISTANCE: VERTICAL AT 3 M**

NO.	FREQ. (MHz)	EMISSION LEVEL (dBuV/m)	LIMIT (dBuV/m)	MARGIN (dB)	ANTENNA HEIGHT (m)	TABLE ANGLE (Degree)	RAW VALUE (dBuV)	CORRECTION FACTOR (dB/m)
1	*5310.00	117.3 PK			1.94 V	96	108.58	8.72
2	*5310.00	105.4 AV			1.94 V	96	96.68	8.72
3	5350.00	64.4 PK	74.0	-9.6	1.94 V	96	55.60	8.80
4	5350.00	53.5 AV	54.0	-0.5	1.94 V	96	44.70	8.80
5	10620.00	49.6 PK	74.0	-24.4	1.58 V	200	35.03	14.57
6	10620.00	38.3 AV	54.0	-15.7	1.58 V	200	23.73	14.57
7	15930.00	58.8 PK	74.0	-15.2	1.50 V	179	39.43	19.37
8	15930.00	42.7 AV	54.0	-11.3	1.50 V	179	23.33	19.37

**REMARKS:**

1. Emission Level(dBuV/m) = Raw Value(dBuV) + Correction Factor(dB/m)
2. Correction Factor(dB/m) = Antenna Factor(dB/m) + Cable Factor(dB) – Pre-Amplifier Factor(dB)
3. The other emission levels were very low against the limit.
4. Margin value = Emission Level – Limit value
5. " \* ": Fundamental frequency.



<b>CHANNEL</b>	TX Channel 102	<b>DETECTOR FUNCTION</b>	Peak (PK)
<b>FREQUENCY RANGE</b>	1GHz ~ 40GHz		Average (AV)

**ANTENNA POLARITY & TEST DISTANCE: HORIZONTAL AT 3 M**

NO.	FREQ. (MHz)	EMISSION LEVEL (dBuV/m)	LIMIT (dBuV/m)	MARGIN (dB)	ANTENNA HEIGHT (m)	TABLE ANGLE (Degree)	RAW VALUE (dBuV)	CORRECTION FACTOR (dB/m)
1	#5470.00	66.1 PK	74.0	-7.9	1.19 H	169	56.92	9.18
2	#5470.00	50.5 AV	54.0	-3.5	1.19 H	169	41.32	9.18
3	*5510.00	101.8 PK			1.19 H	169	92.51	9.29
4	*5510.00	91.2 AV			1.19 H	169	81.91	9.29
5	11020.00	48.9 PK	74.0	-25.1	1.66 H	213	33.63	15.27
6	11020.00	37.3 AV	54.0	-16.7	1.66 H	213	22.03	15.27
7	#16530.00	57.5 PK	74.0	-16.5	1.51 H	321	36.43	21.07
8	#16530.00	42.8 AV	54.0	-11.2	1.51 H	321	21.73	21.07

**ANTENNA POLARITY & TEST DISTANCE: VERTICAL AT 3 M**

NO.	FREQ. (MHz)	EMISSION LEVEL (dBuV/m)	LIMIT (dBuV/m)	MARGIN (dB)	ANTENNA HEIGHT (m)	TABLE ANGLE (Degree)	RAW VALUE (dBuV)	CORRECTION FACTOR (dB/m)
1	#5470.00	68.7 PK	74.0	-5.3	2.20 V	142	59.52	9.18
2	#5470.00	53.3 AV	54.0	-0.7	2.20 V	142	44.12	9.18
3	*5510.00	116.1 PK			2.20 V	142	106.81	9.29
4	*5510.00	104.6 AV			2.20 V	142	95.31	9.29
5	11020.00	50.0 PK	74.0	-24.0	1.63 V	187	34.73	15.27
6	11020.00	38.9 AV	54.0	-15.1	1.63 V	187	23.63	15.27
7	#16530.00	58.6 PK	74.0	-15.4	1.53 V	175	37.53	21.07
8	#16530.00	43.0 AV	54.0	-11.0	1.53 V	175	21.93	21.07

**REMARKS:**

1. Emission Level(dBuV/m) = Raw Value(dBuV) + Correction Factor(dB/m)
2. Correction Factor(dB/m) = Antenna Factor(dB/m) + Cable Factor(dB) – Pre-Amplifier Factor(dB)
3. The other emission levels were very low against the limit.
4. Margin value = Emission Level – Limit value
5. " \* ": Fundamental frequency.
6. " # ": The radiated frequency is out of the restricted band.

<b>CHANNEL</b>	TX Channel 110	<b>DETECTOR FUNCTION</b>	Peak (PK)
<b>FREQUENCY RANGE</b>	1GHz ~ 40GHz		Average (AV)

**ANTENNA POLARITY & TEST DISTANCE: HORIZONTAL AT 3 M**

NO.	FREQ. (MHz)	EMISSION LEVEL (dBuV/m)	LIMIT (dBuV/m)	MARGIN (dB)	ANTENNA HEIGHT (m)	TABLE ANGLE (Degree)	RAW VALUE (dBuV)	CORRECTION FACTOR (dB/m)
1	#5470.00	66.1 PK	74.0	-7.9	1.16 H	184	56.92	9.18
2	#5470.00	50.8 AV	54.0	-3.2	1.16 H	184	41.62	9.18
3	*5550.00	105.6 PK			1.16 H	184	96.27	9.33
4	*5550.00	95.9 AV			1.16 H	184	86.57	9.33
5	#5725.00	54.7 PK	74.0	-19.3	1.16 H	184	45.00	9.70
6	#5725.00	43.2 AV	54.0	-10.8	1.16 H	184	33.50	9.70
7	11100.00	49.0 PK	74.0	-25.0	1.68 H	216	33.75	15.25
8	11100.00	37.1 AV	54.0	-16.9	1.68 H	216	21.85	15.25
9	#16650.00	57.6 PK	74.0	-16.4	1.51 H	318	36.02	21.58
10	#16650.00	42.5 AV	54.0	-11.5	1.51 H	318	20.92	21.58

**ANTENNA POLARITY & TEST DISTANCE: VERTICAL AT 3 M**

NO.	FREQ. (MHz)	EMISSION LEVEL (dBuV/m)	LIMIT (dBuV/m)	MARGIN (dB)	ANTENNA HEIGHT (m)	TABLE ANGLE (Degree)	RAW VALUE (dBuV)	CORRECTION FACTOR (dB/m)
1	#5470.00	68.7 PK	74.0	-5.3	2.23 V	141	59.52	9.18
2	#5470.00	53.4 AV	54.0	-0.6	2.23 V	141	44.22	9.18
3	*5550.00	119.9 PK			2.23 V	141	110.57	9.33
4	*5550.00	109.3 AV			2.23 V	141	99.97	9.33
5	#5725.00	57.3 PK	74.0	-16.7	2.23 V	141	47.60	9.70
6	#5725.00	45.8 AV	54.0	-8.2	2.23 V	141	36.10	9.70
7	11100.00	49.7 PK	74.0	-24.3	1.58 V	199	34.45	15.25
8	11100.00	38.4 AV	54.0	-15.6	1.58 V	199	23.15	15.25
9	#16650.00	58.2 PK	74.0	-15.8	1.47 V	173	36.62	21.58
10	#16650.00	43.6 AV	54.0	-10.4	1.47 V	173	22.02	21.58

**REMARKS:**

1. Emission Level(dBuV/m) = Raw Value(dBuV) + Correction Factor(dB/m)
2. Correction Factor(dB/m) = Antenna Factor(dB/m) + Cable Factor(dB) – Pre-Amplifier Factor(dB)
3. The other emission levels were very low against the limit.
4. Margin value = Emission Level – Limit value
5. " \* ": Fundamental frequency.
6. " # ": The radiated frequency is out of the restricted band.



<b>CHANNEL</b>	TX Channel 134	<b>DETECTOR FUNCTION</b>	Peak (PK)
<b>FREQUENCY RANGE</b>	1GHz ~ 40GHz		Average (AV)

**ANTENNA POLARITY & TEST DISTANCE: HORIZONTAL AT 3 M**

NO.	FREQ. (MHz)	EMISSION LEVEL (dBuV/m)	LIMIT (dBuV/m)	MARGIN (dB)	ANTENNA HEIGHT (m)	TABLE ANGLE (Degree)	RAW VALUE (dBuV)	CORRECTION FACTOR (dB/m)
1	*5670.00	103.7 PK			1.09 H	169	94.15	9.55
2	*5670.00	94.0 AV			1.09 H	169	84.45	9.55
3	#5725.00	65.4 PK	74.0	-8.6	1.09 H	169	55.70	9.70
4	#5725.00	50.7 AV	54.0	-3.3	1.09 H	169	41.00	9.70
5	11340.00	48.6 PK	74.0	-25.4	1.67 H	198	33.36	15.24
6	11340.00	37.8 AV	54.0	-16.2	1.67 H	198	22.56	15.24
7	#17010.00	57.6 PK	74.0	-16.4	1.57 H	321	34.38	23.22
8	#17010.00	43.2 AV	54.0	-10.8	1.57 H	321	19.98	23.22

**ANTENNA POLARITY & TEST DISTANCE: VERTICAL AT 3 M**

NO.	FREQ. (MHz)	EMISSION LEVEL (dBuV/m)	LIMIT (dBuV/m)	MARGIN (dB)	ANTENNA HEIGHT (m)	TABLE ANGLE (Degree)	RAW VALUE (dBuV)	CORRECTION FACTOR (dB/m)
1	*5670.00	118.0 PK			2.00 V	135	108.45	9.55
2	*5670.00	107.3 AV			2.00 V	135	97.75	9.55
3	#5725.00	68.2 PK	74.0	-5.8	2.00 V	135	58.50	9.70
4	#5725.00	53.4 AV	54.0	-0.6	2.00 V	135	43.70	9.70
5	11340.00	49.2 PK	74.0	-24.8	1.57 V	204	33.96	15.24
6	11340.00	38.1 AV	54.0	-15.9	1.57 V	204	22.86	15.24
7	#17010.00	58.4 PK	74.0	-15.6	1.47 V	175	35.18	23.22
8	#17010.00	43.7 AV	54.0	-10.3	1.47 V	175	20.48	23.22

**REMARKS:**

1. Emission Level(dBuV/m) = Raw Value(dBuV) + Correction Factor(dB/m)
2. Correction Factor(dB/m) = Antenna Factor(dB/m) + Cable Factor(dB) – Pre-Amplifier Factor(dB)
3. The other emission levels were very low against the limit.
4. Margin value = Emission Level – Limit value
5. " \* ": Fundamental frequency.
6. " # ": The radiated frequency is out of the restricted band.

**802.11ac (VHT80)**

<b>CHANNEL</b>	TX Channel 58	<b>DETECTOR FUNCTION</b>	Peak (PK)
<b>FREQUENCY RANGE</b>	1GHz ~ 40GHz		Average (AV)

**ANTENNA POLARITY & TEST DISTANCE: HORIZONTAL AT 3 M**

NO.	FREQ. (MHz)	EMISSION LEVEL (dBuV/m)	LIMIT (dBuV/m)	MARGIN (dB)	ANTENNA HEIGHT (m)	TABLE ANGLE (Degree)	RAW VALUE (dBuV)	CORRECTION FACTOR (dB/m)
1	5150.00	51.8 PK	74.0	-22.2	1.16 H	175	43.47	8.33
2	5150.00	38.1 AV	54.0	-15.9	1.16 H	175	29.77	8.33
3	*5290.00	91.7 PK			1.16 H	175	83.02	8.68
4	*5290.00	80.8 AV			1.16 H	175	72.12	8.68
5	5350.00	65.6 PK	74.0	-8.4	1.16 H	175	56.80	8.80
6	5350.00	50.8 AV	54.0	-3.2	1.16 H	175	42.00	8.80
7	#10580.00	48.7 PK	74.0	-25.3	1.59 H	194	34.18	14.52
8	#10580.00	37.9 AV	54.0	-16.1	1.59 H	194	23.38	14.52
9	15870.00	57.3 PK	74.0	-16.7	1.55 H	320	37.95	19.35
10	15870.00	43.0 AV	54.0	-11.0	1.55 H	320	23.65	19.35

**ANTENNA POLARITY & TEST DISTANCE: VERTICAL AT 3 M**

NO.	FREQ. (MHz)	EMISSION LEVEL (dBuV/m)	LIMIT (dBuV/m)	MARGIN (dB)	ANTENNA HEIGHT (m)	TABLE ANGLE (Degree)	RAW VALUE (dBuV)	CORRECTION FACTOR (dB/m)
1	5150.00	52.8 PK	74.0	-21.2	2.04 V	80	44.47	8.33
2	5150.00	38.5 AV	54.0	-15.5	2.04 V	80	30.17	8.33
3	*5290.00	106.0 PK			2.04 V	80	97.32	8.68
4	*5290.00	94.1 AV			2.04 V	80	85.42	8.68
5	5350.00	68.4 PK	74.0	-5.6	2.04 V	80	59.60	8.80
6	5350.00	53.4 AV	54.0	-0.6	2.04 V	80	44.60	8.80
7	#10580.00	49.5 PK	74.0	-24.5	1.60 V	182	34.98	14.52
8	#10580.00	38.6 AV	54.0	-15.4	1.60 V	182	24.08	14.52
9	15870.00	58.8 PK	74.0	-15.2	1.47 V	177	39.45	19.35
10	15870.00	43.8 AV	54.0	-10.2	1.47 V	177	24.45	19.35

**REMARKS:**

- Emission Level(dBuV/m) = Raw Value(dBuV) + Correction Factor(dB/m)
- Correction Factor(dB/m) = Antenna Factor(dB/m) + Cable Factor(dB) – Pre-Amplifier Factor(dB)
- The other emission levels were very low against the limit.
- Margin value = Emission Level – Limit value
- " \* ": Fundamental frequency.
- " # ": The radiated frequency is out of the restricted band.

<b>CHANNEL</b>	TX Channel 106	<b>DETECTOR FUNCTION</b>	Peak (PK)
<b>FREQUENCY RANGE</b>	1GHz ~ 40GHz		Average (AV)

**ANTENNA POLARITY & TEST DISTANCE: HORIZONTAL AT 3 M**

NO.	FREQ. (MHz)	EMISSION LEVEL (dBuV/m)	LIMIT (dBuV/m)	MARGIN (dB)	ANTENNA HEIGHT (m)	TABLE ANGLE (Degree)	RAW VALUE (dBuV)	CORRECTION FACTOR (dB/m)
1	#5470.00	67.4 PK	74.0	-6.6	1.21 H	169	58.22	9.18
2	#5470.00	50.5 AV	54.0	-3.5	1.21 H	169	41.32	9.18
3	*5530.00	93.5 PK			1.21 H	169	84.19	9.31
4	*5530.00	82.3 AV			1.21 H	169	72.99	9.31
5	#5725.00	52.7 PK	74.0	-21.3	1.21 H	169	43.00	9.70
6	#5725.00	41.3 AV	54.0	-12.7	1.21 H	169	31.60	9.70
7	11060.00	48.3 PK	74.0	-25.7	1.68 H	219	33.04	15.26
8	11060.00	37.7 AV	54.0	-16.3	1.68 H	219	22.44	15.26
9	#16590.00	57.6 PK	74.0	-16.4	1.60 H	311	36.16	21.44
10	#16590.00	43.0 AV	54.0	-11.0	1.60 H	311	21.56	21.44

**ANTENNA POLARITY & TEST DISTANCE: VERTICAL AT 3 M**

NO.	FREQ. (MHz)	EMISSION LEVEL (dBuV/m)	LIMIT (dBuV/m)	MARGIN (dB)	ANTENNA HEIGHT (m)	TABLE ANGLE (Degree)	RAW VALUE (dBuV)	CORRECTION FACTOR (dB/m)
1	#5470.00	70.3 PK	74.0	-3.7	1.79 V	143	61.12	9.18
2	#5470.00	53.2 AV	54.0	-0.8	1.79 V	143	44.02	9.18
3	*5530.00	107.8 PK			1.79 V	143	98.49	9.31
4	*5530.00	95.6 AV			1.79 V	143	86.29	9.31
5	#5725.00	53.3 PK	74.0	-20.7	1.79 V	143	43.60	9.70
6	#5725.00	43.7 AV	54.0	-10.3	1.79 V	143	34.00	9.70
7	11060.00	49.5 PK	74.0	-24.5	1.60 V	178	34.24	15.26
8	11060.00	38.4 AV	54.0	-15.6	1.60 V	178	23.14	15.26
9	#16590.00	58.5 PK	74.0	-15.5	2.02 V	91	37.06	21.44
10	#16590.00	43.5 AV	54.0	-10.5	2.02 V	91	22.06	21.44

**REMARKS:**

1. Emission Level(dBuV/m) = Raw Value(dBuV) + Correction Factor(dB/m)
2. Correction Factor(dB/m) = Antenna Factor(dB/m) + Cable Factor(dB) – Pre-Amplifier Factor(dB)
3. The other emission levels were very low against the limit.
4. Margin value = Emission Level – Limit value
5. " \* ": Fundamental frequency.
6. " # ": The radiated frequency is out of the restricted band.



<b>CHANNEL</b>	TX Channel 122	<b>DETECTOR FUNCTION</b>	Peak (PK)
<b>FREQUENCY RANGE</b>	1GHz ~ 40GHz		Average (AV)

**ANTENNA POLARITY & TEST DISTANCE: HORIZONTAL AT 3 M**

NO.	FREQ. (MHz)	EMISSION LEVEL (dBuV/m)	LIMIT (dBuV/m)	MARGIN (dB)	ANTENNA HEIGHT (m)	TABLE ANGLE (Degree)	RAW VALUE (dBuV)	CORRECTION FACTOR (dB/m)
1	*5610.00	101.5 PK			1.19 H	179	92.11	9.39
2	*5610.00	92.5 AV			1.19 H	179	83.11	9.39
3	#5725.00	65.7 PK	74.0	-8.3	1.19 H	179	56.00	9.70
4	#5725.00	50.6 AV	54.0	-3.4	1.19 H	179	40.90	9.70
5	11220.00	49.0 PK	74.0	-25.0	1.66 H	195	33.78	15.22
6	11220.00	37.3 AV	54.0	-16.7	1.66 H	195	22.08	15.22
7	#16830.00	57.3 PK	74.0	-16.7	1.50 H	314	35.19	22.11
8	#16830.00	43.2 AV	54.0	-10.8	1.50 H	314	21.09	22.11

**ANTENNA POLARITY & TEST DISTANCE: VERTICAL AT 3 M**

NO.	FREQ. (MHz)	EMISSION LEVEL (dBuV/m)	LIMIT (dBuV/m)	MARGIN (dB)	ANTENNA HEIGHT (m)	TABLE ANGLE (Degree)	RAW VALUE (dBuV)	CORRECTION FACTOR (dB/m)
1	*5610.00	115.8 PK			2.54 V	132	106.41	9.39
2	*5610.00	105.8 AV			2.54 V	132	96.41	9.39
3	#5725.00	68.3 PK	74.0	-5.7	2.54 V	132	58.60	9.70
4	#5725.00	53.2 AV	54.0	-0.8	2.54 V	132	43.50	9.70
5	11220.00	49.6 PK	74.0	-24.4	1.57 V	178	34.38	15.22
6	11220.00	38.7 AV	54.0	-15.3	1.57 V	178	23.48	15.22
7	#16830.00	58.9 PK	74.0	-15.1	1.45 V	163	36.79	22.11
8	#16830.00	44.1 AV	54.0	-9.9	1.45 V	163	21.99	22.11

**REMARKS:**

1. Emission Level(dBuV/m) = Raw Value(dBuV) + Correction Factor(dB/m)
2. Correction Factor(dB/m) = Antenna Factor(dB/m) + Cable Factor(dB) – Pre-Amplifier Factor(dB)
3. The other emission levels were very low against the limit.
4. Margin value = Emission Level – Limit value
5. " \* ": Fundamental frequency.
6. " # ": The radiated frequency is out of the restricted band.



**Below 1GHz Data:**
**802.11ac (VHT80)**

<b>CHANNEL</b>	TX Channel 122	<b>DETECTOR FUNCTION</b>	Quasi-Peak (QP)
<b>FREQUENCY RANGE</b>	Below 1GHz		

**ANTENNA POLARITY & TEST DISTANCE: HORIZONTAL AT 3 M**

NO.	FREQ. (MHz)	EMISSION LEVEL (dBuV/m)	LIMIT (dBuV/m)	MARGIN (dB)	ANTENNA HEIGHT (m)	TABLE ANGLE (Degree)	RAW VALUE (dBuV)	CORRECTION FACTOR (dB/m)
1	39.54	32.6 QP	40.0	-7.4	1.50 H	257	41.50	-8.91
2	68.05	28.2 QP	40.0	-11.8	1.00 H	205	38.09	-9.93
3	250.02	32.7 QP	46.0	-13.3	1.50 H	299	41.95	-9.27
4	375.01	37.1 QP	46.0	-8.9	1.00 H	152	42.51	-5.45
5	500.00	28.7 QP	46.0	-17.3	1.00 H	147	31.43	-2.70
6	750.01	34.3 QP	46.0	-11.7	1.00 H	325	31.85	2.49

**ANTENNA POLARITY & TEST DISTANCE: VERTICAL AT 3 M**

NO.	FREQ. (MHz)	EMISSION LEVEL (dBuV/m)	LIMIT (dBuV/m)	MARGIN (dB)	ANTENNA HEIGHT (m)	TABLE ANGLE (Degree)	RAW VALUE (dBuV)	CORRECTION FACTOR (dB/m)
1	68.82	35.6 QP	40.0	-4.4	1.00 V	111	45.47	-9.86
2	88.32	28.8 QP	43.5	-14.7	1.00 V	61	42.77	-13.98
3	250.02	30.2 QP	46.0	-15.8	1.00 V	7	39.50	-9.27
4	375.01	33.6 QP	46.0	-12.4	1.00 V	49	39.03	-5.45
5	500.03	28.8 QP	46.0	-17.2	1.00 V	288	31.53	-2.70
6	750.01	31.8 QP	46.0	-14.2	1.50 V	215	29.30	2.49

**REMARKS:**

1. Emission Level(dBuV/m) = Raw Value(dBuV) + Correction Factor(dB/m)
2. Correction Factor(dB/m) = Antenna Factor(dB/m) + Cable Factor(dB) – Pre-Amplifier Factor(dB)
3. The other emission levels were very low against the limit.
4. Margin value = Emission Level – Limit value

## 4.2 Conducted Emission Measurement

### 4.2.1 Limits of Conducted Emission Measurement

Frequency (MHz)	Conducted Limit (dBuV)	
	Quasi-peak	Average
0.15 - 0.5	66 - 56	56 - 46
0.50 - 5.0	56	46
5.0 - 30.0	60	50

Note: 1. The lower limit shall apply at the transition frequencies.

2. The limit decreases in line with the logarithm of the frequency in the range of 0.15 to 0.50MHz.

### 4.2.2 Test Instruments

DESCRIPTION & MANUFACTURER	MODEL NO.	SERIAL NO.	CALIBRATED DATE	CALIBRATED UNTIL
Test Receiver R&S	ESCS 30	100375	May 06, 2015	May 05, 2016
Line-Impedance Stabilization Network (for EUT) SCHWARZBECK	NSLK-8127	8127-522	Sep. 01, 2015	Aug. 31, 2016
Line-Impedance Stabilization Network (for Peripheral ) R&S	ENV216	100072	June 11, 2015	June 10, 2016
RF Cable	5D-FB	COCCAB-001	Mar. 09, 2015	Mar. 08, 2016
50 ohms Terminator	N/A	EMC-03	Sep. 23, 2015	Sep. 22, 2016
50 ohms Terminator	N/A	EMC-02	Oct. 01, 2015	Sep. 30, 2016
Software BVADT	BVADT_Cond_ V7.3.7.3	NA	NA	NA

**Note:**

1. The calibration interval of the above test instruments are 12 months and the calibrations are traceable to NML/ROC and NIST/USA.
2. The test was performed in Shielded Room No. C.
3. The VCCI Con C Registration No. is C-3611.
4. Tested Date: Dec. 16, 2015

#### 4.2.3 Test Procedure

- a. The EUT was placed 0.4 meters from the conducting wall of the shielded room with EUT being connected to the power mains through a line impedance stabilization network (LISN). Other support units were connected to the power mains through another LISN. The two LISNs provide 50 ohm/ 50uH of coupling impedance for the measuring instrument.
- b. Both lines of the power mains connected to the EUT were checked for maximum conducted interference.
- c. The frequency range from 150kHz to 30MHz was searched. Emission levels under (Limit - 20dB) was not recorded.

**NOTE:** All modes of operation were investigated and the worst-case emissions are reported.

#### 4.2.4 Deviation from Test Standard

No deviation.

#### 4.2.5 Test Setup

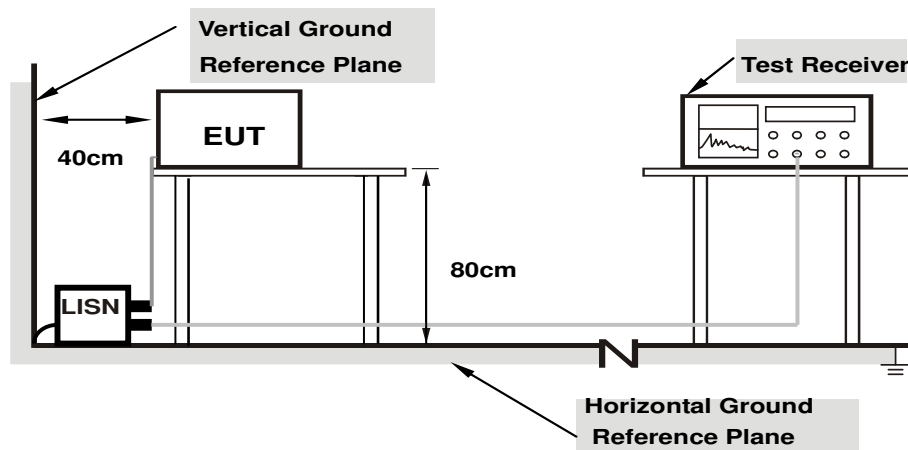

**Note: 1.Support units were connected to second LISN.**

For the actual test configuration, please refer to the attached file (Test Setup Photo).

#### 4.2.6 EUT Operating Condition

Same as 4.1.6.

4.2.7 Test Results

Phase	Line (L)	Detector Function	Quasi-Peak (QP) / Average (AV)
-------	----------	-------------------	--------------------------------

No	Freq. [MHz]	Corr.	Reading Value		Emission Level		Limit		Margin	
		Factor (dB)	[dB (uV)]		[dB (uV)]		[dB (uV)]		(dB)	
	Q.P.	AV.	Q.P.	AV.	Q.P.	AV.	Q.P.	AV.	Q.P.	AV.
1	0.18125	10.36	33.62	19.75	43.98	30.11	64.43	54.43	-20.45	-24.32
2	0.22422	10.34	31.09	14.97	41.43	25.31	62.66	52.66	-21.23	-27.35
3	0.35703	10.36	32.52	9.76	42.88	20.12	58.80	48.80	-15.91	-28.67
4	0.50156	10.36	29.48	18.57	39.84	28.93	56.00	46.00	-16.16	-17.07
5	0.56016	10.36	20.84	5.78	31.20	16.14	56.00	46.00	-24.80	-29.86
6	0.72422	10.34	18.54	5.71	28.88	16.05	56.00	46.00	-27.12	-29.95
7	0.79453	10.34	16.70	4.53	27.04	14.87	56.00	46.00	-28.96	-31.13
8	19.95313	11.46	21.04	15.35	32.50	26.81	60.00	50.00	-27.50	-23.19

**REMARKS:**

1. Q.P. and AV. are abbreviations of quasi-peak and average individually.
2. The emission levels of other frequencies were very low against the limit.
3. Margin value = Emission level - Limit value
4. Correction factor = Insertion loss + Cable loss
5. Emission Level = Correction Factor + Reading Value

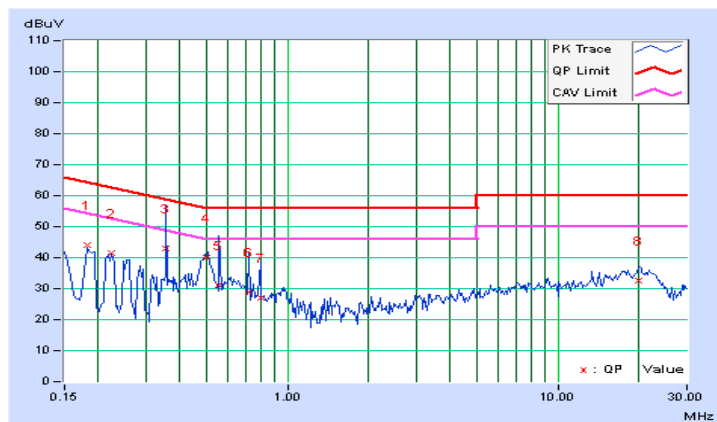

Phase	Neutral (N)	Detector Function	Quasi-Peak (QP) / Average (AV)
-------	-------------	-------------------	--------------------------------

No	Freq. [MHz]	Corr. Factor	Reading Value [dB (uV)]		Emission Level [dB (uV)]		Limit [dB (uV)]		Margin (dB)	
		(dB)	Q.P.	AV.	Q.P.	AV.	Q.P.	AV.	Q.P.	AV.
	<b>1</b>	<b>0.29063</b>	<b>10.40</b>	<b>35.86</b>	<b>10.76</b>	<b>46.26</b>	<b>21.16</b>	<b>60.51</b>	<b>50.51</b>	<b>-14.24</b>
2	0.39219	10.42	30.50	9.10	40.92	19.52	58.02	48.02	-17.10	-28.50
3	0.43906	10.42	22.71	13.53	33.13	23.95	57.08	47.08	-23.95	-23.13
4	0.50000	10.41	29.44	19.13	39.85	29.54	56.00	46.00	-16.15	-16.46
5	0.61875	10.40	21.77	10.29	32.17	20.69	56.00	46.00	-23.83	-25.31
6	0.67734	10.40	23.70	8.28	34.10	18.68	56.00	46.00	-21.90	-27.32
7	13.35938	11.14	22.20	17.62	33.34	28.76	60.00	50.00	-26.66	-21.24

**REMARKS:**

1. Q.P. and AV. are abbreviations of quasi-peak and average individually.
2. The emission levels of other frequencies were very low against the limit.
3. Margin value = Emission level - Limit value
4. Correction factor = Insertion loss + Cable loss
5. Emission Level = Correction Factor + Reading Value

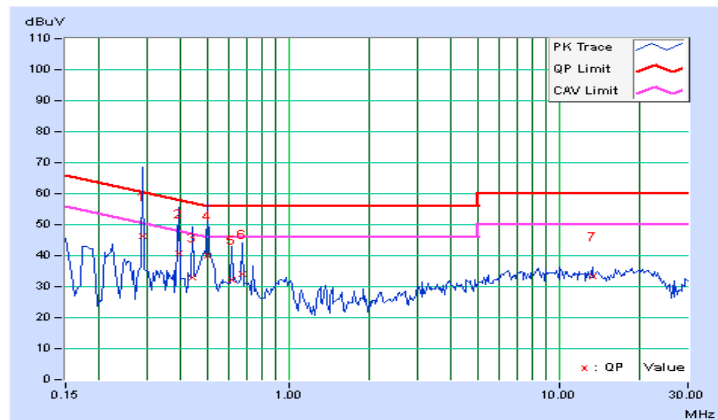

### 4.3 Transmit Power Measurement

#### 4.3.1 Limits of Transmit Power Measurement

Operation Band	EUT Category		LIMIT
U-NII-1	---	Outdoor Access Point	1 Watt (30 dBm) (Max. e.i.r.p $\leq$ 125mW(21 dBm) at any elevation angle above 30 degrees as measured from the horizon)
	---	Fixed point-to-point Access Point	1 Watt (30 dBm)
	---	Indoor Access Point	1 Watt (30 dBm)
	---	Mobile and Portable client device	250mW (24 dBm)
U-NII-2A	√		250mW (24 dBm) or 11 dBm+10 log B*
U-NII-2C	√		250mW (24 dBm) or 11 dBm+10 log B*
U-NII-3	---		1 Watt (30 dBm)

\*B is the 26 dB emission bandwidth in megahertz

Per KDB 662911 Method of conducted output power measurement on IEEE 802.11 devices,

Array Gain = 0 dB (i.e., no array gain) for  $N_{ANT} \leq 4$ ;

Array Gain = 0 dB (i.e., no array gain) for channel widths  $\geq 40$  MHz for any  $N_{ANT}$ ;

Array Gain =  $5 \log(N_{ANT}/N_{SS})$  dB or 3 dB, whichever is less for 20-MHz channel widths with  $N_{ANT} \geq 5$ .

For power measurements on all other devices: Array Gain =  $10 \log(N_{ANT}/N_{SS})$  dB.

#### 4.3.2 Test Setup

##### FOR POWER OUTPUT MEASUREMENT

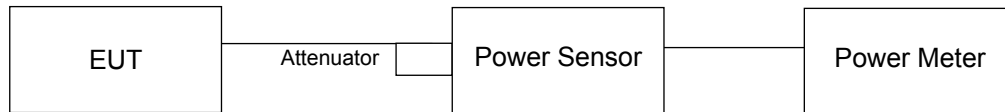

##### FOR 26dB OCCUPIED BANDWIDTH

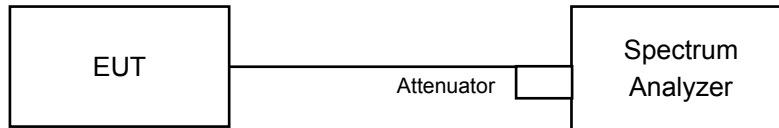

#### 4.3.3 Test Instruments

Refer to section 4.1.2 to get information of above instrument.

#### 4.3.4 Test Procedure

##### FOR POWER OUTPUT MEASUREMENT

Method PM is used to perform output power measurement, trigger and gating function of wide band power meter with average sensor is enabled to measure max output power of TX on burst. Duty factor is not added to measured value.

##### FOR 26dB OCCUPIED BANDWIDTH

1. Set RBW = approximately 1% of the emission bandwidth.
2. Set the VBW > RBW.
3. Detector = Peak.
4. Trace mode = max hold.
5. Measure the maximum width of the emission that is 26 dB down from the peak of the emission. Compare this with the RBW setting of the analyzer. Readjust RBW and repeat measurement as needed until the RBW/EBW ratio is approximately 1%.

#### 4.3.5 Deviation from Test Standard

No deviation.

#### 4.3.6 EUT Operating Condition

The software provided by client to enable the EUT under transmission condition continuously at lowest, middle and highest channel frequencies individually.

**4.3.7 Test Result (Mode 1 – Chain 0)**
**802.11a**
**POWER OUTPUT**

Chan.	Chan. Freq. (MHz)	Average Power (mW)	Average Power (dBm)	Limit (dBm)	Pass / Fail
52	5260	179.473	22.54	23.83	Pass
60	5300	180.302	22.56	23.83	Pass
64	5320	179.473	22.54	23.83	Pass
100	5500	166.341	22.21	24.00	Pass
116	5580	182.39	22.61	24.00	Pass
140	5700	162.555	22.11	24.00	Pass

**Note:** 1. 5250 – 5350MHz: The directional gain is 6.17dBi > 6dBi, therefore the limit needs to reduce, so the power density limit shall be reduced to  $24 - (6.17 - 6) = 23.83\text{dBm}$ .

**26dB OCCUPIED BANDWIDTH**

Channel	Frequency (MHz)	26dBc Bandwidth (MHz)
52	5260	21.84
60	5300	23.43
64	5320	22.06
100	5500	21.88
116	5580	22.53
140	5700	22.40

**Note: For U-NII-2A, U-NII-2C Band output power limitation is determined based on 26dBc bandwidth**

Power Limit = $11\text{dBm} + 10\log B < \text{U-NII-2A, U-NII-2C} >$			
Channel Number	Freq.(MHz)	Min. B(MHz)	Determined Conducted Limit (dBm)
52	5260	21.84	24.39 > 24
60	5300	23.43	24.69 > 24
64	5320	22.06	24.43 > 24
100	5500	21.88	24.4 > 24
116	5580	22.53	24.52 > 24
140	5700	22.40	24.5 > 24



**802.11ac (VHT20)**
**POWER OUTPUT**

Chan.	Chan. Freq. (MHz)	Average Power (mW)	Average Power (dBm)	Limit (dBm)	Pass / Fail
52	5260	181.134	22.58	23.83	Pass
60	5300	182.39	22.61	23.83	Pass
64	5320	182.81	22.62	23.83	Pass
100	5500	159.221	22.02	24.00	Pass
116	5580	180.717	22.57	24.00	Pass
140	5700	163.305	22.13	24.00	Pass

**Note:** 1. 5250 – 5350MHz: The directional gain is 6.17dBi > 6dBi, therefore the limit needs to reduce, so the power limit shall be reduced to “Determined Conducted Limit-(6.17-6)”

**26dB OCCUPIED BANDWIDTH**

Channel	Frequency (MHz)	26dBc Bandwidth (MHz)
52	5260	23.24
60	5300	23.01
64	5320	23.21
100	5500	23.07
116	5580	23.48
140	5700	23.06

**Note: For U-NII-2A, U-NII-2C Band output power limitation is determined based on 26dBc bandwidth**

Power Limit = 11dBm + 10logB < U-NII-2A, U-NII-2C >			
Channel Number	Freq.(MHz)	Min. B(MHz)	Determined Conducted Limit (dBm)
52	5260	23.24	24.66 > 24
60	5300	23.01	24.61 > 24
64	5320	23.21	24.65 > 24
100	5500	23.07	24.63 > 24
116	5580	23.48	24.7 > 24
140	5700	23.06	24.62 > 24

**802.11ac (VHT40)**
**POWER OUTPUT**

Chan.	Chan. Freq. (MHz)	Average Power (mW)	Average Power (dBm)	Limit (dBm)	Pass / Fail
54	5270	157.761	21.98	23.83	Pass
62	5310	174.181	22.41	23.83	Pass
102	5510	109.901	20.41	24.00	Pass
110	5550	163.305	22.13	24.00	Pass
134	5670	157.761	21.98	24.00	Pass

**Note:** 1. 5250 – 5350MHz: The directional gain is 6.17dBi > 6dBi, therefore the limit needs to reduce, so the power limit shall be reduced to “Determined Conducted Limit-(6.17-6)”

**26dB OCCUPIED BANDWIDTH**

Channel	Frequency (MHz)	26dBc Bandwidth (MHz)
54	5270	47.83
62	5310	46.41
102	5510	45.17
110	5550	46.99
134	5670	47.03

**Note:** For U-NII-2A, U-NII-2C Band output power limitation is determined based on 26dBc bandwidth

Power Limit = 11dBm + 10logB < U-NII-2A, U-NII-2C >			
Channel Number	Freq.(MHz)	Min. B(MHz)	Determined Conducted Limit (dBm)
54	5270	47.83	27.79 > 24
62	5310	46.41	27.66 > 24
102	5510	45.17	27.54 > 24
110	5550	46.99	27.72 > 24
134	5670	47.03	27.72 > 24

**802.11ac (VHT80)**
**POWER OUTPUT**

Chan.	Chan. Freq. (MHz)	Average Power (mW)	Average Power (dBm)	Limit (dBm)	Pass / Fail
58	5290	88.716	19.48	23.83	Pass
106	5530	49.774	16.97	24.00	Pass
122	5610	174.181	22.41	24.00	Pass

**Note:** 1. 5250 – 5350MHz: The directional gain is 6.17dBi > 6dBi, therefore the limit needs to reduce, so the power limit shall be reduced to “Determined Conducted Limit-(6.17-6)”

**26dB OCCUPIED BANDWIDTH**

Channel	Frequency (MHz)	26dBc Bandwidth (MHz)
58	5290	88.61
106	5530	87.76
122	5610	90.74

**Note:** For U-NII-2A, U-NII-2C Band output power limitation is determined based on 26dBc bandwidth

Power Limit = 11dBm + 10logB < U-NII-2A, U-NII-2C >			
Channel Number	Freq.(MHz)	Min. B(MHz)	Determined Conducted Limit (dBm)
58	5290	88.61	30.47 > 24
106	5530	87.76	30.43 > 24
122	5610	90.74	30.57 > 24

Spectrum Plot of Worst Value

802.11a: CH52

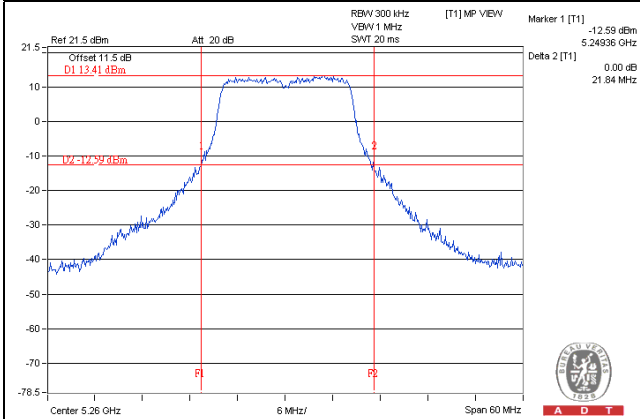

802.11ac (VHT20): CH60

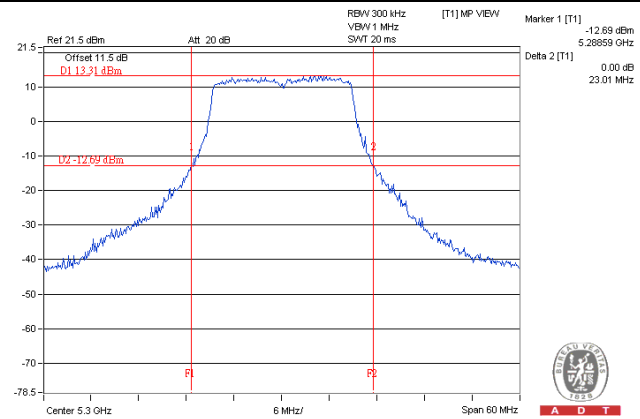

802.11ac (VHT40): CH102

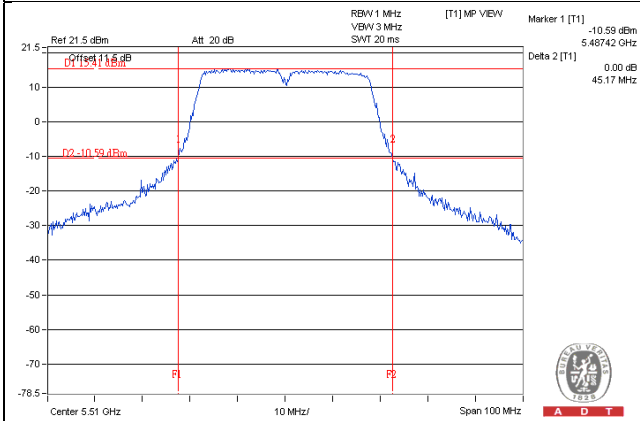

802.11ac (VHT80): CH106

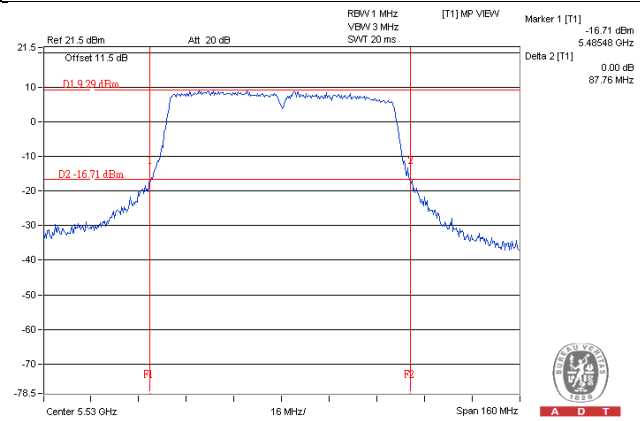

**4.3.8 Test Result (Mode 2 – Chain 1)**
**802.11a**
**POWER OUTPUT**

Chan.	Chan. Freq. (MHz)	Average Power (mW)	Average Power (dBm)	Limit (dBm)	Pass / Fail
52	5260	193.642	22.87	24	Pass
60	5300	190.108	22.79	24	Pass
64	5320	185.78	22.69	24	Pass
100	5500	186.638	22.71	24	Pass
116	5580	190.108	22.79	24	Pass
140	5700	191.867	22.83	24	Pass

**26dB OCCUPIED BANDWIDTH**

Channel	Frequency (MHz)	26dBc Bandwidth (MHz)
52	5260	22.70
60	5300	22.90
64	5320	22.21
100	5500	22.56
116	5580	22.39
140	5700	22.54

**Note: For U-NII-2A, U-NII-2C Band output power limitation is determined based on 26dBc bandwidth**

Power Limit = 11dBm + 10logB < U-NII-2A, U-NII-2C >			
Channel Number	Freq.(MHz)	Min. B(MHz)	Determined Conducted Limit (dBm)
52	5260	22.70	24.56 > 24
60	5300	22.90	24.59 > 24
64	5320	22.21	24.46 > 24
100	5500	22.56	24.53 > 24
116	5580	22.39	24.5 > 24
140	5700	22.54	24.52 > 24

**802.11ac (VHT20)**
**POWER OUTPUT**

Chan.	Chan. Freq. (MHz)	Average Power (mW)	Average Power (dBm)	Limit (dBm)	Pass / Fail
52	5260	190.985	22.81	24	Pass
60	5300	187.068	22.72	24	Pass
64	5320	182.39	22.61	24	Pass
100	5500	183.231	22.63	24	Pass
116	5580	186.638	22.71	24	Pass
140	5700	165.196	22.18	24	Pass

**26dB OCCUPIED BANDWIDTH**

Channel	Frequency (MHz)	26dBc Bandwidth (MHz)
52	5260	23.23
60	5300	22.92
64	5320	23.39
100	5500	23.22
116	5580	23.89
140	5700	23.04

**Note: For U-NII-2A, U-NII-2C Band output power limitation is determined based on 26dBc bandwidth**

Power Limit = 11dBm + 10logB < U-NII-2A, U-NII-2C >			
Channel Number	Freq.(MHz)	Min. B(MHz)	Determined Conducted Limit (dBm)
52	5260	23.23	24.66 > 24
60	5300	22.92	24.6 > 24
64	5320	23.39	24.69 > 24
100	5500	23.22	24.65 > 24
116	5580	23.89	24.78 > 24
140	5700	23.04	24.62 > 24

**802.11ac (VHT40)**
**POWER OUTPUT**

Chan.	Chan. Freq. (MHz)	Average Power (mW)	Average Power (dBm)	Limit (dBm)	Pass / Fail
54	5270	190.985	22.81	24	Pass
62	5310	186.638	22.71	24	Pass
102	5510	88.92	19.49	24	Pass
110	5550	189.671	22.78	24	Pass
134	5670	190.985	22.81	24	Pass

**26dB OCCUPIED BANDWIDTH**

Channel	Frequency (MHz)	26dBc Bandwidth (MHz)
54	5270	45.91
62	5310	45.99
102	5510	45.69
110	5550	46.80
134	5670	46.12

**Note: For U-NII-2A, U-NII-2C Band output power limitation is determined based on 26dBc bandwidth**

Power Limit = 11dBm + 10logB < U-NII-2A, U-NII-2C >			
Channel Number	Freq.(MHz)	Min. B(MHz)	Determined Conducted Limit (dBm)
54	5270	45.91	27.61 > 24
62	5310	45.99	27.62 > 24
102	5510	45.69	27.59 > 24
110	5550	46.80	27.7 > 24
134	5670	46.12	27.63 > 24

**802.11ac (VHT80)**
**POWER OUTPUT**

Chan.	Chan. Freq. (MHz)	Average Power (mW)	Average Power (dBm)	Limit (dBm)	Pass / Fail
58	5290	118.577	20.74	24	Pass
106	5530	67.92	18.32	24	Pass
122	5610	113.763	20.56	24	Pass

**26dB OCCUPIED BANDWIDTH**

Channel	Frequency (MHz)	26dBc Bandwidth (MHz)
58	5290	87.59
106	5530	88.09
122	5610	86.94

**Note: For U-NII-2A, U-NII-2C Band output power limitation is determined based on 26dBc bandwidth**

Power Limit = 11dBm + 10logB < U-NII-2A, U-NII-2C >			
Channel Number	Freq.(MHz)	Min. B(MHz)	Determined Conducted Limit (dBm)
58	5290	87.59	30.42 > 24
106	5530	88.09	30.44 > 24
122	5610	86.94	30.39 > 24



Spectrum Plot of Worst Value

802.11a: CH64

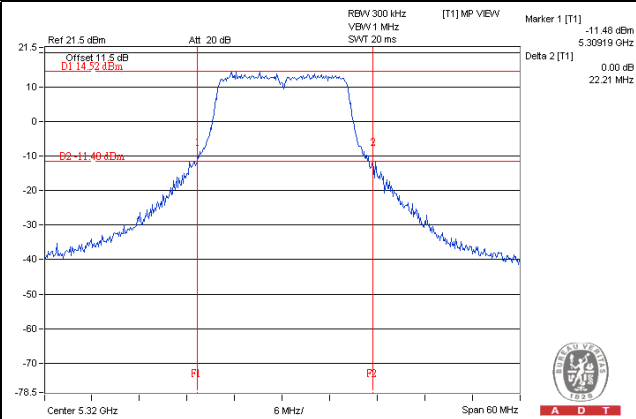

802.11ac (VHT20): CH60

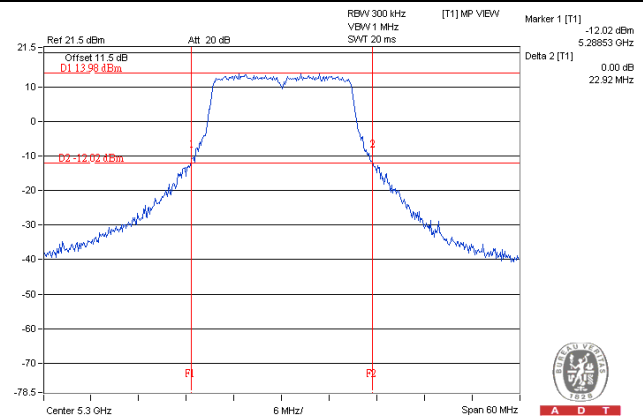

802.11ac (VHT40): CH102

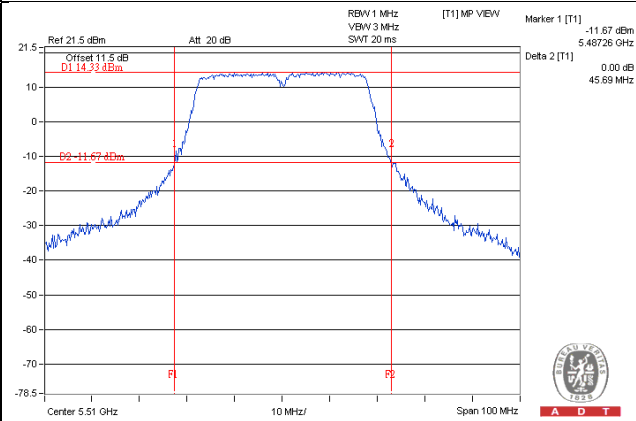

802.11ac (VHT80): CH122

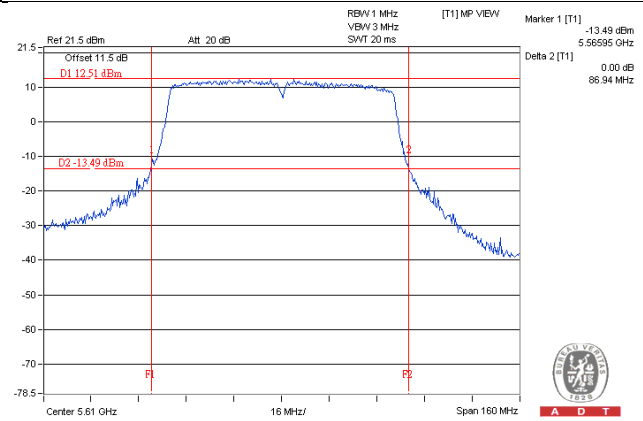

#### 4.3.9 Test Result (Mode 3 – 2TX)

##### 802.11a

##### POWER OUTPUT

Chan.	Chan. Freq. (MHz)	Maximum Conducted Power (dBm)		Total Power (mW)	Total Power (dBm)	Power Limit (dBm)	Pass / Fail
		Chain 0	Chain 1				
52	5260	17.89	18.36	130.067	21.14	23.83	Pass
60	5300	17.99	18.25	129.785	21.13	23.83	Pass
64	5320	17.56	18.45	127	21.04	23.83	Pass
100	5500	18.13	18.72	139.486	21.45	24.00	Pass
116	5580	18.18	18.48	136.235	21.34	24.00	Pass
140	5700	17.72	18.55	130.77	21.17	24.00	Pass

**Note:** 5.250 - 5.350 GHz: The directional gain is 6.17dBi > 6dBi, therefore the limit needs to reduce, so the power limit shall be reduced to "Determined Conducted Limit-(6.17-6)"

##### 26dB OCCUPIED BANDWIDTH

Channel	Frequency (MHz)	26dBc Bandwidth (MHz)	
		Chain 0	Chain 1
52	5260	21.84	21.36
60	5300	22.72	21.16
64	5320	22.29	21.86
100	5500	21.74	21.83
116	5580	22.05	22.21
140	5700	21.84	21.67

**Note:** For U-NII-2A, U-NII-2C Band output power limitation is determined based on 26dBc bandwidth

Power Limit = 11dBm + 10logB < U-NII-2A, U-NII-2C >			
Channel Number	Freq.(MHz)	Min. B(MHz)	Determined Conducted Limit (dBm)
52	5260	21.36	24.29 > 24
60	5300	21.16	24.25 > 24
64	5320	21.86	24.39 > 24
100	5500	21.74	24.37 > 24
116	5580	22.05	24.43 > 24
140	5700	21.67	24.35 > 24

**802.11ac (VHT20)**
**POWER OUTPUT**

Chan.	Chan. Freq. (MHz)	Maximum Conducted Power (dBm)		Total Power (mW)	Total Power (dBm)	Power Limit (dBm)	Pass / Fail
		Chain 0	Chain 1				
52	5260	17.85	18.27	128.097	21.08	23.83	Pass
60	5300	17.96	18.38	131.382	21.19	23.83	Pass
64	5320	17.99	18.56	134.73	21.29	23.83	Pass
100	5500	17.55	18.57	128.83	21.10	24.00	Pass
116	5580	17.66	18.58	130.456	21.15	24.00	Pass
140	5700	17.67	18.57	130.424	21.15	24.00	Pass

**Note:** 5.250 - 5.350 GHz: The directional gain is 6.17dBi > 6dBi, therefore the limit needs to reduce, so the power limit shall be reduced to "Determined Conducted Limit-(6.17-6)"

**26dB OCCUPIED BANDWIDTH**

Channel	Frequency (MHz)	26dBc Bandwidth (MHz)	
		Chain 0	Chain 1
52	5260	22.84	23.15
60	5300	22.97	22.62
64	5320	23.81	22.90
100	5500	23.08	22.78
116	5580	23.50	22.33
140	5700	23.44	22.60

**Note:** For U-NII-2A, U-NII-2C Band output power limitation is determined based on 26dBc bandwidth

Power Limit = 11dBm + 10logB < U-NII-2A, U-NII-2C >			
Channel Number	Freq.(MHz)	Min. B(MHz)	Determined Conducted Limit (dBm)
52	5260	22.84	24.58 > 24
60	5300	22.62	24.54 > 24
64	5320	22.90	24.59 > 24
100	5500	22.78	24.57 > 24
116	5580	22.33	24.48 > 24
140	5700	22.60	24.54 > 24

**802.11ac (VHT40)**
**POWER OUTPUT**

Chan.	Chan. Freq. (MHz)	Maximum Conducted Power (dBm)		Total Power (mW)	Total Power (dBm)	Power Limit (dBm)	Pass / Fail
		Chain 0	Chain 1				
54	5270	20.37	20.61	223.973	23.50	23.83	Pass
62	5310	19.26	19.66	176.803	22.47	23.83	Pass
102	5510	17.66	18.57	130.29	21.15	24.00	Pass
110	5550	20.39	20.97	234.422	23.70	24.00	Pass
134	5670	20.15	21.25	236.866	23.75	24.00	Pass

**Note:** 5.250 - 5.350 GHz: The directional gain is 6.17dBi > 6dBi, therefore the limit needs to reduce, so the power limit shall be reduced to "Determined Conducted Limit-(6.17-6)"

**26dB OCCUPIED BANDWIDTH**

Channel	Frequency (MHz)	26dBc Bandwidth (MHz)	
		Chain 0	Chain 1
54	5270	46.08	45.56
62	5310	45.86	44.70
102	5510	45.49	45.27
110	5550	46.71	46.05
134	5670	46.75	44.43

**Note:** For U-NII-2A, U-NII-2C Band output power limitation is determined based on 26dBc bandwidth

Power Limit = 11dBm + 10logB < U-NII-2A, U-NII-2C >			
Channel Number	Freq.(MHz)	Min. B(MHz)	Determined Conducted Limit (dBm)
54	5270	45.56	27.58 > 24
62	5310	44.70	27.5 > 24
102	5510	45.27	27.55 > 24
110	5550	46.05	27.63 > 24
134	5670	44.43	27.47 > 24

**802.11ac (VHT80)**
**POWER OUTPUT**

Chan.	Chan. Freq. (MHz)	Maximum Conducted Power (dBm)		Total Power (mW)	Total Power (dBm)	Power Limit (dBm)	Pass / Fail
		Chain 0	Chain 1				
58	5290	14.61	15.58	65.048	18.13	23.83	Pass
106	5530	13.23	14.28	47.83	16.80	24.00	Pass
122	5610	20.65	21.00	242.038	23.84	24.00	Pass

**Note:** 5.250 - 5.350 GHz: The directional gain is 6.17dBi > 6dBi, therefore the limit needs to reduce, so the power limit shall be reduced to "Determined Conducted Limit-(6.17-6)"

**26dB OCCUPIED BANDWIDTH**

Channel	Frequency (MHz)	26dBc Bandwidth (MHz)	
		Chain 0	Chain 1
58	5290	86.80	89.26
106	5530	88.21	85.62
122	5610	90.51	86.95

**Note:** For U-NII-2A, U-NII-2C Band output power limitation is determined based on 26dBc bandwidth

Power Limit = 11dBm + 10logB < U-NII-2A, U-NII-2C >			
Channel Number	Freq.(MHz)	Min. B(MHz)	Determined Conducted Limit (dBm)
58	5290	86.80	30.38 > 24
106	5530	85.62	30.32 > 24
122	5610	86.95	30.39 > 24

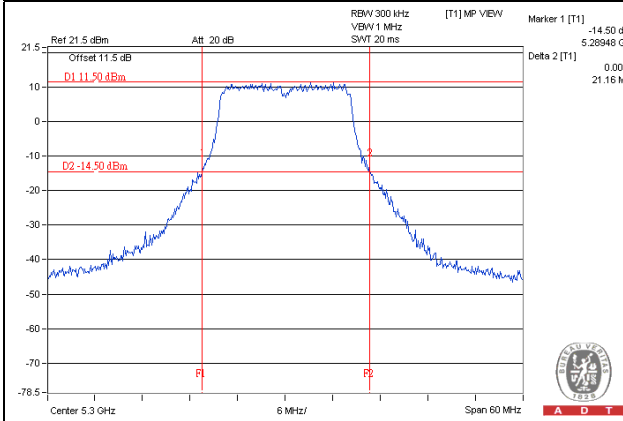
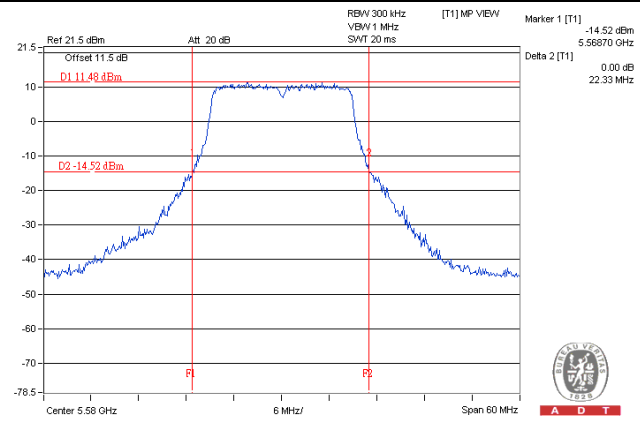
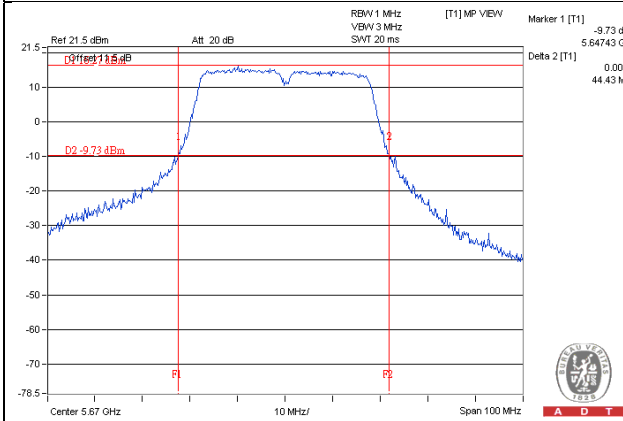
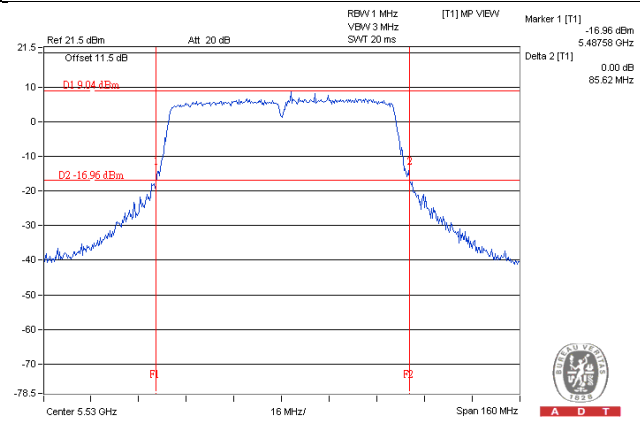
**Spectrum Plot of Worst Value****802.11a: Chain 1 / CH60****802.11ac (VHT20): Chain 1 / CH16****802.11ac (VHT40): Chain 1 / CH134****802.11ac (VHT80): Chain 1 / CH106**

## 4.4 Peak Power Spectral Density Measurement

### 4.4.1 Limits of Peak Power Spectral Density Measurement

Operation Band	EUT Category		LIMIT
U-NII-1	---	Outdoor Access Point	17dBm/ MHz
	---	Fixed point-to-point Access Point	
	---	Indoor Access Point	
	---	Mobile and Portable client device	11dBm/ MHz
U-NII-2A	√		11dBm/ MHz
U-NII-2C	√		11dBm/ MHz
U-NII-3	---		30dBm/ 500kHz

### 4.4.2 Test Setup



### 4.4.3 Test Instruments

Refer to section 4.1.2 to get information of above instrument.

### 4.4.4 Test Procedure

#### For 802.11a, 802.11ac (VHT20):

Using method SA-1

1. Set span to encompass the entire emission bandwidth (EBW) of the signal.
2. Set RBW = 1 MHz, Set VBW ≥ 3 MHz, Detector = RMS
3. Sweep time = auto, trigger set to "free run".
4. Trace average at least 100 traces in power averaging mode.
5. Record the max value

#### For 802.11ac (VHT40) & 802.11ac (VHT80):

Using method SA-2

1. Set span to encompass the entire emission bandwidth (EBW) of the signal.
2. Set RBW = 1 MHz, Set VBW ≥ 3 MHz, Detector = RMS
3. Sweep time = auto, trigger set to "free run".
4. Trace average at least 100 traces in power averaging mode.
5. Record the max value and add 10 log (1/duty cycle)

### 4.4.5 Deviation from Test Standard

No deviation.

### 4.4.6 EUT Operating Condition

Same as Item 4.3.6.

#### 4.4.7 Test Results (Mode 1 – Chain 0)

##### 802.11a

Chan.	Chan. Freq. (MHz)	PSD (dBm/MHz)	MAX. Limit (dBm/MHz)	Pass / Fail
52	5260	8.13	10.83	Pass
60	5300	8.57	10.83	Pass
64	5320	8.59	10.83	Pass
100	5500	8.37	11.00	Pass
116	5580	8.72	11.00	Pass
140	5700	7.86	11.00	Pass

**Note:** 1. 5250 – 5350MHz: The directional gain is 6.17dBi > 6dBi, therefore the limit needs to reduce, so the power density limit shall be reduced to  $11-(6.17-6) = 10.83\text{dBm}$ .

##### 802.11ac (VHT20)

Chan.	Chan. Freq. (MHz)	PSD (dBm/MHz)	MAX. Limit (dBm/MHz)	Pass / Fail
52	5260	7.86	10.83	Pass
60	5300	8.26	10.83	Pass
64	5320	8.31	10.83	Pass
100	5500	8.07	11.00	Pass
116	5580	8.36	11.00	Pass
140	5700	7.49	11.00	Pass

**Note:** 1. 5250 – 5350MHz: The directional gain is 6.17dBi > 6dBi, therefore the limit needs to reduce, so the power density limit shall be reduced to  $11-(6.17-6) = 10.83\text{dBm}$ .



**802.11ac (VHT40)**

Chan.	Chan. Freq. (MHz)	Conducted PSD W/O Duty Factor (dBm/MHz)	Duty Factor (dB)	PSD With Duty Factor (dBm/MHz)	MAX. EIRP Limit (dBm/MHz)	Pass / Fail
54	5270	4.41	0.15	4.56	10.83	Pass
62	5310	5.01	0.15	5.16	10.83	Pass
102	5510	4.34	0.15	4.49	11.00	Pass
110	5550	5.01	0.15	5.16	11.00	Pass
134	5670	3.86	0.15	4.01	11.00	Pass

**Note:** 1. 5250 – 5350MHz: The directional gain is 6.17dBi > 6dBi, therefore the limit needs to reduce, so the power density limit shall be reduced to  $11-(6.17-6) = 10.83\text{dBm}$ .

2. Refer to section 3.3 for duty cycle spectrum plot.

**802.11ac (VHT80)**

Chan.	Chan. Freq. (MHz)	Conducted PSD W/O Duty Factor (dBm/MHz)	Duty Factor (dB)	PSD With Duty Factor (dBm/MHz)	MAX. EIRP Limit (dBm/MHz)	Pass / Fail
58	5290	-0.07	0.29	0.22	10.83	Pass
106	5530	-2.32	0.29	-2.03	11.00	Pass
122	5610	2.58	0.29	2.87	11.00	Pass

**Note:** 1. 5250 – 5350MHz: The directional gain is 6.17dBi > 6dBi, therefore the limit needs to reduce, so the power density limit shall be reduced to  $11-(6.17-6) = 10.83\text{dBm}$ .

2. Refer to section 3.3 for duty cycle spectrum plot.

## Spectrum Plot of Worst Value

802.11a: CH116

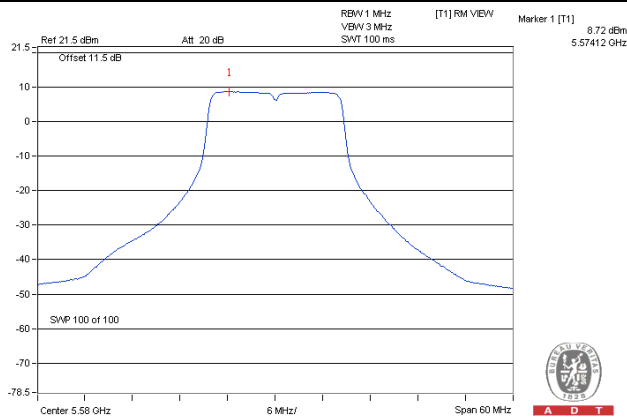

802.11ac (VHT20): CH116

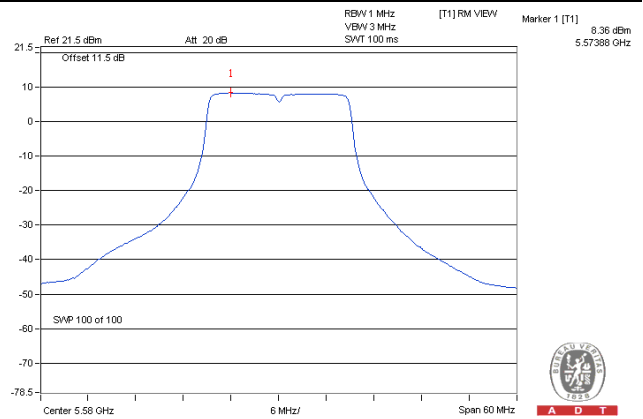

802.11ac (VHT40): CH62

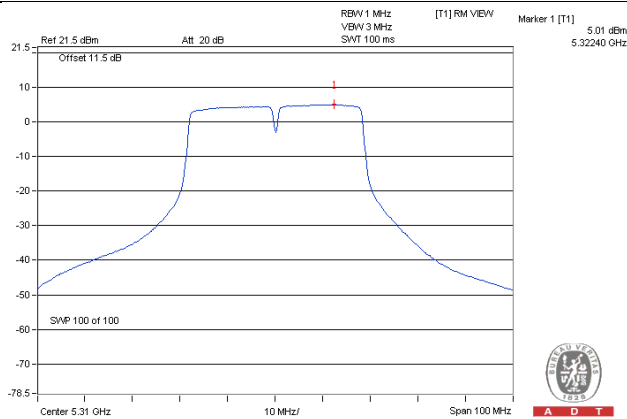

802.11ac (VHT80): CH122

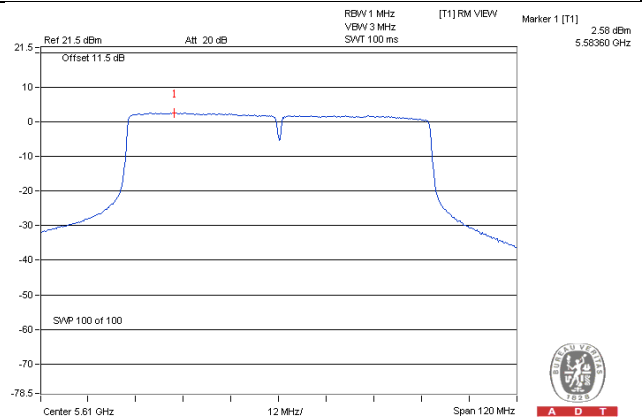

## 4.4.8 Test Results (Mode 2 – Chain 1)

## 802.11a

Chan.	Chan. Freq. (MHz)	PSD (dBm/MHz)	MAX. Limit (dBm/MHz)	Pass / Fail
52	5260	9.16	11	Pass
60	5300	9.05	11	Pass
64	5320	8.85	11	Pass
100	5500	9.07	11	Pass
116	5580	9.11	11	Pass
140	5700	8.60	11	Pass

## 802.11ac (VHT20)

Chan.	Chan. Freq. (MHz)	PSD (dBm/MHz)	MAX. Limit (dBm/MHz)	Pass / Fail
52	5260	8.97	11	Pass
60	5300	8.62	11	Pass
64	5320	8.48	11	Pass
100	5500	8.96	11	Pass
116	5580	8.85	11	Pass
140	5700	8.42	11	Pass

**802.11ac (VHT40)**

Chan.	Chan. Freq. (MHz)	Conducted PSD W/O Duty Factor (dBm/MHz)	Duty Factor (dB)	PSD With Duty Factor (dBm/MHz)	MAX. EIRP Limit (dBm/MHz)	Pass / Fail
54	5270	5.20	0.15	5.35	11	Pass
62	5310	5.12	0.15	5.27	11	Pass
102	5510	3.26	0.15	3.41	11	Pass
110	5550	5.66	0.15	5.81	11	Pass
134	5670	5.42	0.15	5.57	11	Pass

**Note:** 1. Refer to section 3.3 for duty cycle spectrum plot.

**802.11ac (VHT80)**

Chan.	Chan. Freq. (MHz)	Conducted PSD W/O Duty Factor (dBm/MHz)	Duty Factor (dB)	PSD With Duty Factor (dBm/MHz)	MAX. EIRP Limit (dBm/MHz)	Pass / Fail
58	5290	0.73	0.29	1.02	11	Pass
106	5530	-1.10	0.29	-0.81	11	Pass
122	5610	0.82	0.29	1.11	11	Pass

**Note:** 1. Refer to section 3.3 for duty cycle spectrum plot.

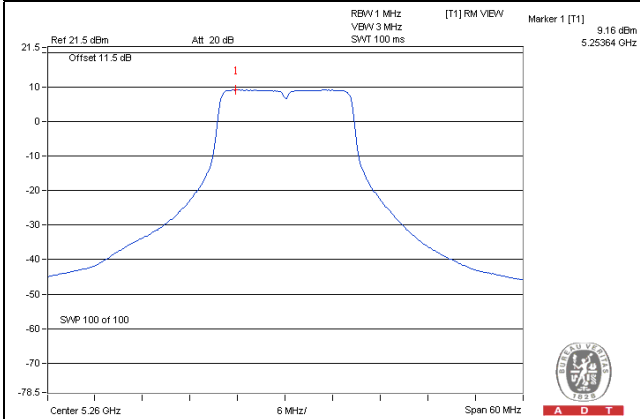
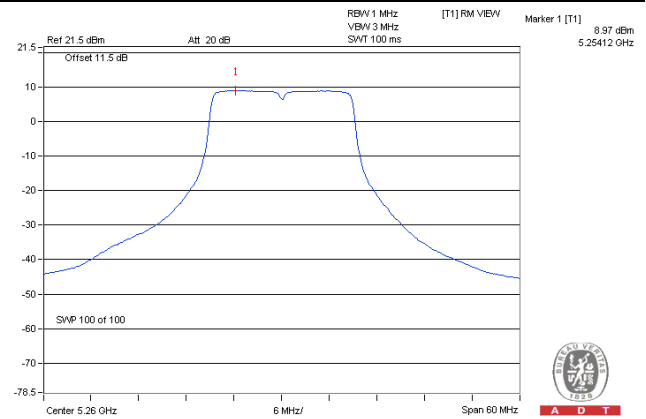
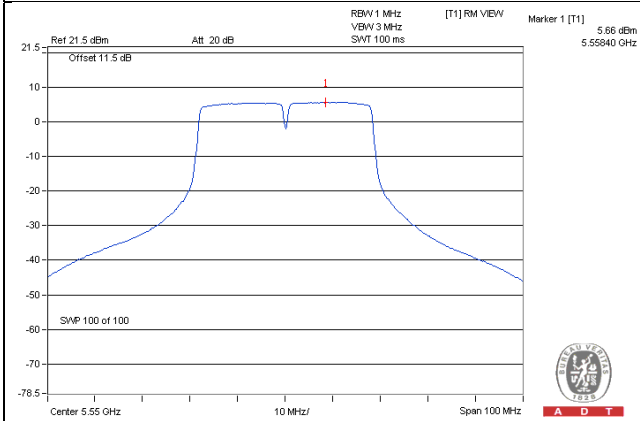
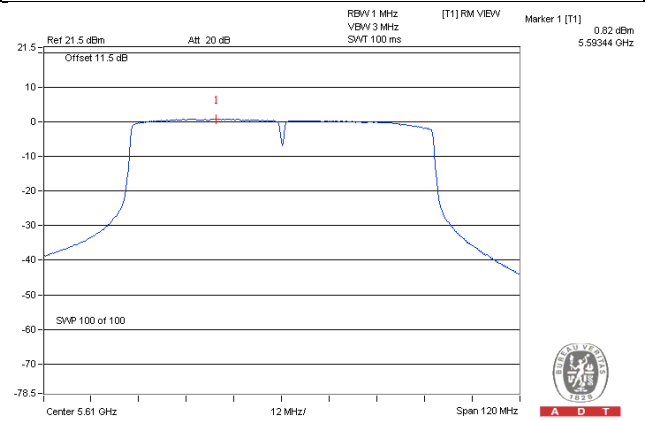
**Spectrum Plot of Worst Value****802.11a: CH52****802.11ac (VHT20): CH52****802.11ac (VHT40): CH110****802.11ac (VHT80): CH122**

#### 4.4.9 Test Results (Mode 3 – 2TX)

##### 802.11a

Chan.	Chan. Freq. (MHz)	PSD (dBm)		Total Power Density (dBm)	Max. Limit (dBm)	Pass / Fail
		Chain 0	Chain 1			
52	5260	3.97	5.55	7.84	8.43	Pass
60	5300	4.30	5.31	7.84	8.43	Pass
64	5320	4.40	5.23	7.85	8.43	Pass
100	5500	4.02	5.78	8.00	8.59	Pass
116	5580	5.32	5.41	8.38	8.59	Pass
140	5700	4.32	4.66	7.50	8.59	Pass

**NOTE:** 1. Method 1 of power density measurement of KDB 662911 is using for calculating total power density. Total power density is summing entire spectra across corresponding frequency bins on the various outputs by computer.

2. 5250 – 5350MHz: Directional gain =  $10 \log[(10^{G1/20} + 10^{G2/20})^2 / 2] = 8.57\text{dBi} > 6\text{dBi}$  , so the power density limit shall be reduced to  $11-(8.57-6) = 8.43\text{dBm}$ .

3. 5470 – 5725MHz: Directional gain =  $10 \log[(10^{G1/20} + 10^{G2/20})^2 / 2] = 8.41\text{dBi} > 6\text{dBi}$  , so the power density limit shall be reduced to  $11-(8.41-6) = 8.59\text{dBm}$ .

##### 802.11ac (VHT20)

Chan.	Chan. Freq. (MHz)	PSD (dBm)		Total Power Density (dBm)	Max. Limit (dBm)	Pass / Fail
		Chain 0	Chain 1			
52	5260	5.32	5.17	8.26	8.43	Pass
60	5300	5.46	4.98	8.24	8.43	Pass
64	5320	4.65	5.34	8.02	8.43	Pass
100	5500	4.62	4.87	7.76	8.59	Pass
116	5580	4.58	5.94	8.32	8.59	Pass
140	5700	4.48	4.90	7.71	8.59	Pass

**NOTE:** 1. Method 1 of power density measurement of KDB 662911 is using for calculating total power density. Total power density is summing entire spectra across corresponding frequency bins on the various outputs by computer.

2. 5250 – 5350MHz: Directional gain =  $10 \log[(10^{G1/20} + 10^{G2/20})^2 / 2] = 8.57\text{dBi} > 6\text{dBi}$  , so the power density limit shall be reduced to  $11-(8.57-6) = 8.43\text{dBm}$ .

3. 5470 – 5725MHz: Directional gain =  $10 \log[(10^{G1/20} + 10^{G2/20})^2 / 2] = 8.41\text{dBi} > 6\text{dBi}$  , so the power density limit shall be reduced to  $11-(8.41-6) = 8.59\text{dBm}$ .

**802.11ac (VHT40)**

Chan.	Freq. (MHz)	PSD w/o Duty Factor (dBm)		Duty Factor	Total PSD with Duty Factor (dBm)	Max. Limit (dBm)	Pass / Fail
		Chain 0	Chain 1				
54	5270	4.10	3.94	0.15	7.18	8.43	Pass
62	5310	3.08	2.37	0.15	5.90	8.43	Pass
102	5510	1.95	1.89	0.15	5.08	8.59	Pass
110	5550	5.09	5.23	0.15	8.32	8.59	Pass
134	5670	3.36	4.19	0.15	6.95	8.59	Pass

**NOTE:** 1. Method 1 of power density measurement of KDB 662911 is using for calculating total power density. Total power density is summing entire spectra across corresponding frequency bins on the various outputs by computer.

2. 5250 – 5350MHz: Directional gain =  $10 \log[(10^{G1/20} + 10^{G2/20})^2 / 2]$  = 8.57dBi > 6dBi , so the power density limit shall be reduced to  $11-(8.57-6)$  = 8.43dBm.

3. 5470 – 5725MHz: Directional gain =  $10 \log[(10^{G1/20} + 10^{G2/20})^2 / 2]$  = 8.41dBi > 6dBi , so the power density limit shall be reduced to  $11-(8.41-6)$  = 8.59dBm.

4. Refer to section 3.3 for duty cycle spectrum plot.

**802.11ac (VHT80)**

Chan.	Freq. (MHz)	PSD w/o Duty Factor (dBm)		Duty Factor	Total PSD with Duty Factor (dBm)	Max. Limit (dBm)	Pass / Fail
		Chain 0	Chain 1				
58	5290	-4.65	-4.88	0.29	-1.47	8.43	Pass
106	5530	-5.79	-5.11	0.29	-2.14	8.59	Pass
122	5610	1.70	2.29	0.29	5.30	8.59	Pass

**NOTE:** 1. Method 1 of power density measurement of KDB 662911 is using for calculating total power density. Total power density is summing entire spectra across corresponding frequency bins on the various outputs by computer.

2. 5250 – 5350MHz: Directional gain =  $10 \log[(10^{G1/20} + 10^{G2/20})^2 / 2]$  = 8.57dBi > 6dBi , so the power density limit shall be reduced to  $11-(8.57-6)$  = 8.43dBm.

3. 5470 – 5725MHz: Directional gain =  $10 \log[(10^{G1/20} + 10^{G2/20})^2 / 2]$  = 8.41dBi > 6dBi , so the power density limit shall be reduced to  $11-(8.41-6)$  = 8.59dBm.

4. Refer to section 3.3 for duty cycle spectrum plot.

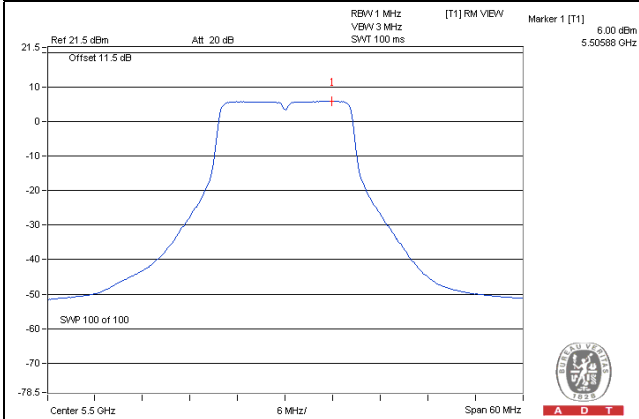
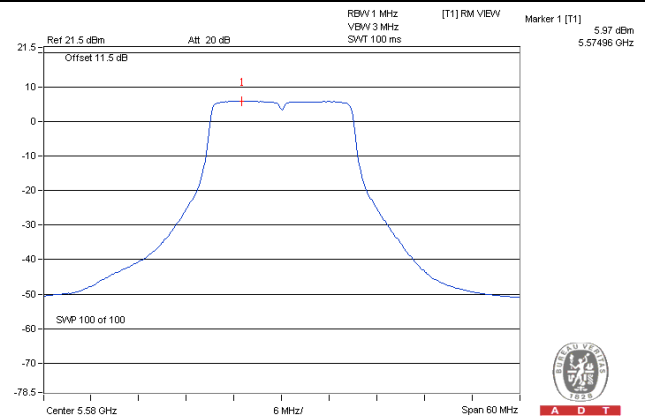
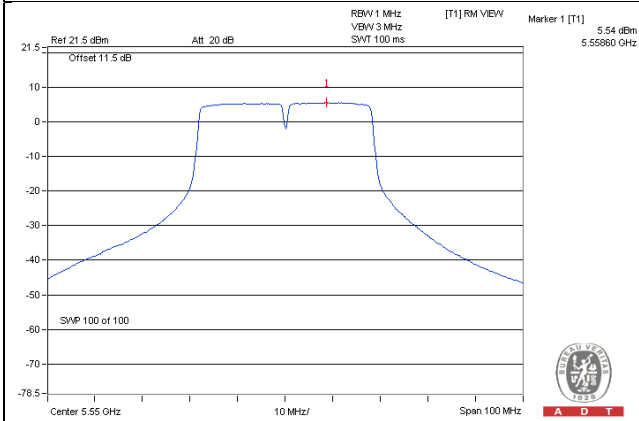
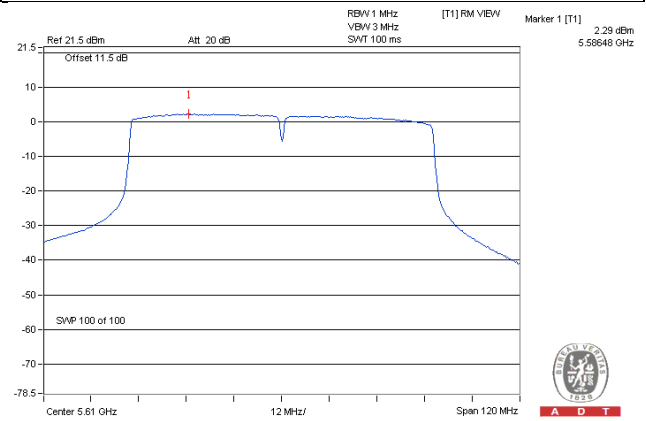
**Spectrum Plot of Worst Value****802.11a: Chain 1 / CH100****802.11ac (VHT20): Chain 1 / CH116****802.11ac (VHT40): Chain 1 / CH110****802.11ac (VHT80): Chain 1 / CH122**



## 4.5 Frequency Stability Measurement

### 4.5.1 Limits of Frequency Stability Measurement

The frequency of the carrier signal shall be maintained within band of operation

### 4.5.2 Test Setup

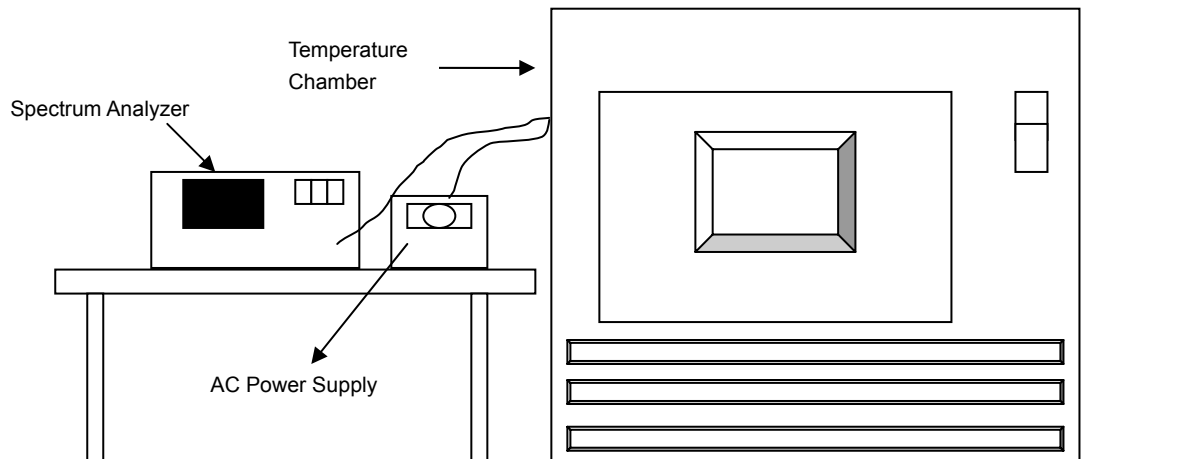

### 4.5.3 Test Instruments

Refer to section 4.1.2 to get information of above instrument.

### 4.5.4 Test Procedure

- a. The EUT was placed inside the environmental test chamber and powered by nominal AC voltage.
- b. Turn the EUT on and couple its output to a spectrum analyzer.
- c. Turn the EUT off and set the chamber to the highest temperature specified.
- d. Allow sufficient time (approximately 30 min) for the temperature of the chamber to stabilize, turn the EUT on and measure the operating frequency after 2, 5, and 10 minutes.
- e. Repeat step 2 and 3 with the temperature chamber set to the lowest temperature.
- f. The test chamber was allowed to stabilize at +20 degree C for a minimum of 30 minutes. The supply voltage was then adjusted on the EUT from 85% to 115% and the frequency record.

### 4.5.5 Deviation from Test Standard

No deviation.

### 4.5.6 EUT Operating Condition

Set the EUT transmit at un-modulation mode to test frequency stability.

**4.5.7 Test Results**

<b>FREQUENCY STABILITY VERSUS TEMP.</b>									
<b>OPERATING FREQUENCY: 5260MHz</b>									
<b>TEMP. (°C)</b>	<b>POWER SUPPLY (Vac)</b>	<b>0 MINUTE</b>		<b>2 MINUTE</b>		<b>5 MINUTE</b>		<b>10 MINUTE</b>	
		<b>Measured Frequency (MHz)</b>	<b>Frequency Drift (%)</b>	<b>Measured Frequency (MHz)</b>	<b>Frequency Drift (%)</b>	<b>Measured Frequency (MHz)</b>	<b>Frequency Drift (%)</b>	<b>Measured Frequency (MHz)</b>	<b>Frequency Drift (%)</b>
50	120	5260.0149	0.00028	5260.0146	0.00028	5260.0157	0.00030	5260.0161	0.00031
40	120	5259.994	-0.00011	5259.9922	-0.00015	5259.9896	-0.00020	5259.9909	-0.00017
30	120	5260.011	0.00021	5260.009	0.00017	5260.0105	0.00020	5260.0115	0.00022
20	120	5260.0017	0.00003	5260.0024	0.00005	5260.0022	0.00004	5260.0003	0.00001
10	120	5260.0092	0.00017	5260.0074	0.00014	5260.0104	0.00020	5260.0083	0.00016
0	120	5260.0106	0.00020	5260.0106	0.00020	5260.0144	0.00027	5260.0138	0.00026
-10	120	5259.9955	-0.00009	5259.9959	-0.00008	5259.9966	-0.00006	5259.9963	-0.00007
-20	120	5260.0017	0.00003	5259.9998	0.00000	5260.0037	0.00007	5260.0009	0.00002
-30	120	5260.0269	0.00051	5260.0231	0.00044	5260.0264	0.00050	5260.0244	0.00046

<b>FREQUENCY STABILITY VERSUS VOLTAGE</b>									
<b>OPERATING FREQUENCY: 5260MHz</b>									
<b>TEMP. (°C)</b>	<b>POWER SUPPLY (Vac)</b>	<b>0 MINUTE</b>		<b>2 MINUTE</b>		<b>5 MINUTE</b>		<b>10 MINUTE</b>	
		<b>Measured Frequency (MHz)</b>	<b>Frequency Drift (%)</b>	<b>Measured Frequency (MHz)</b>	<b>Frequency Drift (%)</b>	<b>Measured Frequency (MHz)</b>	<b>Frequency Drift (%)</b>	<b>Measured Frequency (MHz)</b>	<b>Frequency Drift (%)</b>
20	138	5260.0013	0.00002	5260.0032	0.00006	5260.0023	0.00004	5260.0004	0.00001
	120	5260.0017	0.00003	5260.0024	0.00005	5260.0022	0.00004	5260.0003	0.00001
	102	5260.0026	0.00005	5260.002	0.00004	5260.003	0.00006	5260	0.00000

## 4.6 Occupied Bandwidth Measurement

### 4.6.1 Test Setup

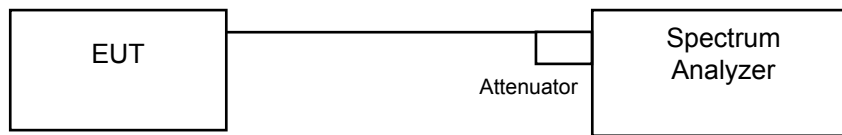

### 4.6.2 Test Instruments

Refer to section 4.1.2 to get information of above instrument.

### 4.6.3 Test Procedure

The transmitter output was connected to the spectrum analyzer through an attenuator. The bandwidth of the fundamental frequency was measured by spectrum analyzer with resolution bandwidth in the range of 1% to 5% of the anticipated emission bandwidth, and a video bandwidth at least 3x the resolution bandwidth and set the detector to PEAK. The width of a frequency band such that, below the lower and above the upper frequency limits, the mean powers emitted are each equal to a specified percentage 0.5 %of the total mean power of a given emission.

### 4.6.4 Deviation from Test Standard

No deviation.

### 4.6.5 EUT Operating Conditions

The software provided by client to enable the EUT under transmission condition continuously at lowest, middle and highest channel frequencies individually.

**4.6.6 Test Results (Mode 1 – Chain 0)**
**802.11a**

Channel	Frequency (MHz)	Occupied Bandwidth (MHz)
52	5260	16.80
60	5300	16.68
64	5320	16.80
100	5500	16.80
116	5580	16.80
140	5700	16.80

**802.11ac (VHT20)**

Channel	Frequency (MHz)	Occupied Bandwidth (MHz)
52	5260	17.88
60	5300	17.88
64	5320	18.00
100	5500	18.00
116	5580	18.00
140	5700	18.00

**802.11ac (VHT40)**

Channel	Frequency (MHz)	Occupied Bandwidth (MHz)
54	5270	36.60
62	5310	36.80
102	5510	36.60
110	5550	36.60
134	5670	37.00

**802.11ac (VHT80)**

Channel	Frequency (MHz)	Occupied Bandwidth (MHz)
58	5290	76.08
106	5530	75.84
122	5610	76.08

Spectrum Plot of Worst Value

802.11a: CH52

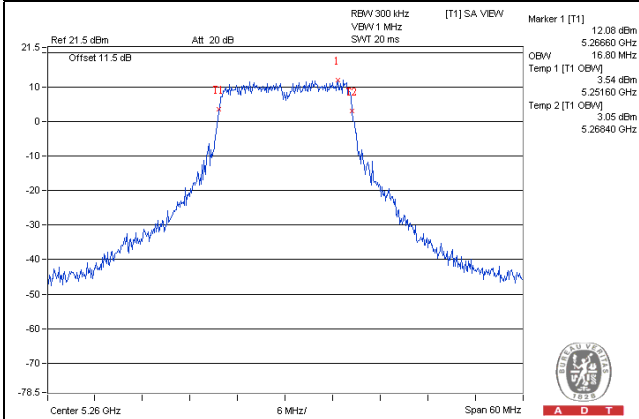

802.11ac (VHT20): CH64

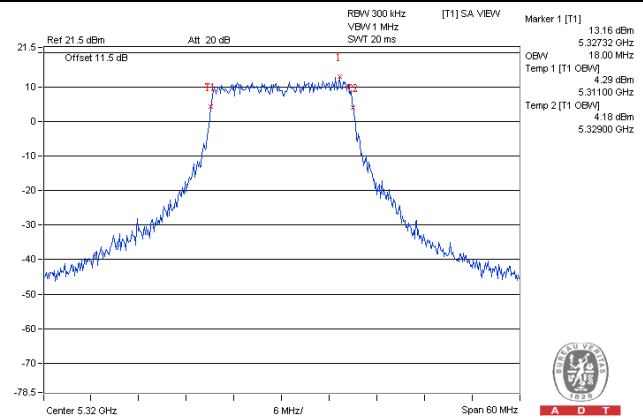

802.11ac (VHT40): CH134

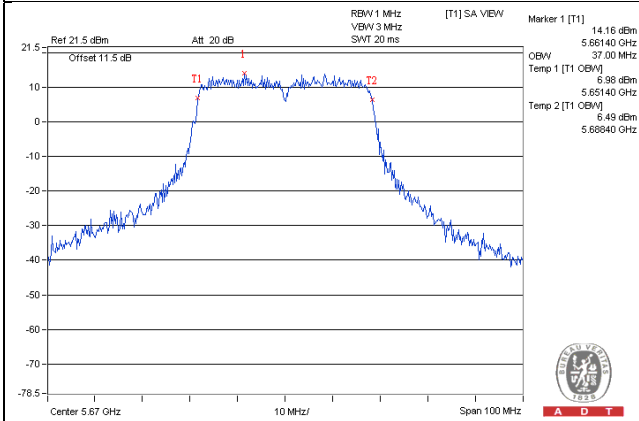

802.11ac (VHT80): CH58

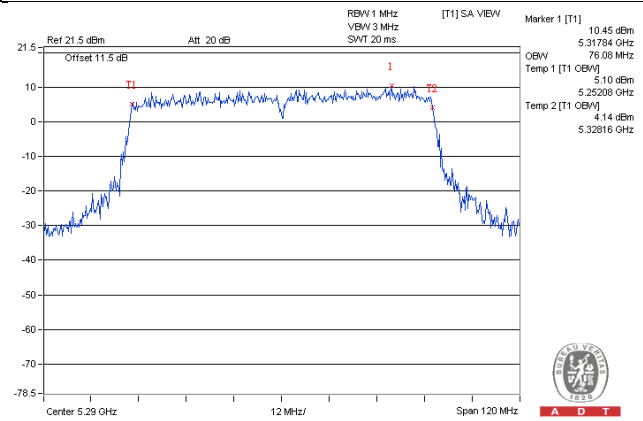

**4.6.7 Test Results (Mode 2 – Chain 1)**
**802.11a**

Channel	Frequency (MHz)	Occupied Bandwidth (MHz)
52	5260	16.80
60	5300	16.68
64	5320	16.80
100	5500	16.68
116	5580	16.80
140	5700	16.80

**802.11ac (VHT20)**

Channel	Frequency (MHz)	Occupied Bandwidth (MHz)
52	5260	18.00
60	5300	17.88
64	5320	17.88
100	5500	17.88
116	5580	17.88
140	5700	17.88

**802.11ac (VHT40)**

Channel	Frequency (MHz)	Occupied Bandwidth (MHz)
54	5270	36.80
62	5310	36.80
102	5510	36.80
110	5550	36.80
134	5670	36.80

**802.11ac (VHT80)**

Channel	Frequency (MHz)	Occupied Bandwidth (MHz)
58	5290	75.84
106	5530	76.08
122	5610	75.84

Spectrum Plot of Worst Value

802.11a: CH52

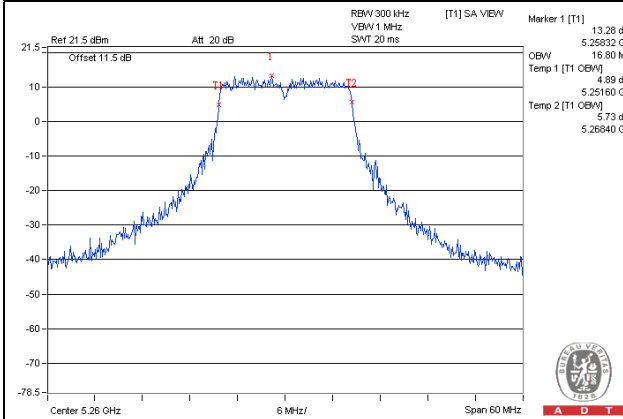

802.11ac (VHT20): CH52

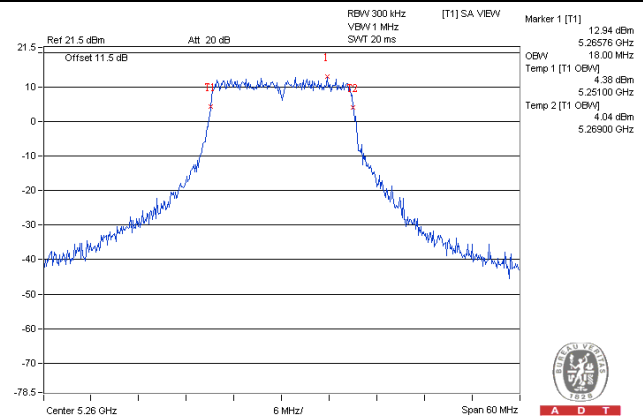

802.11ac (VHT40): CH54

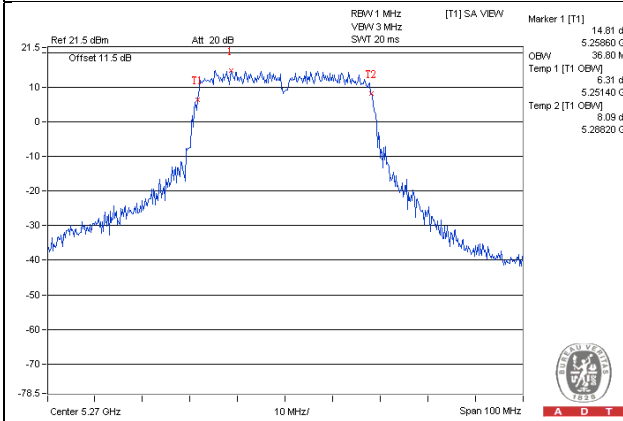

802.11ac (VHT80): CH106

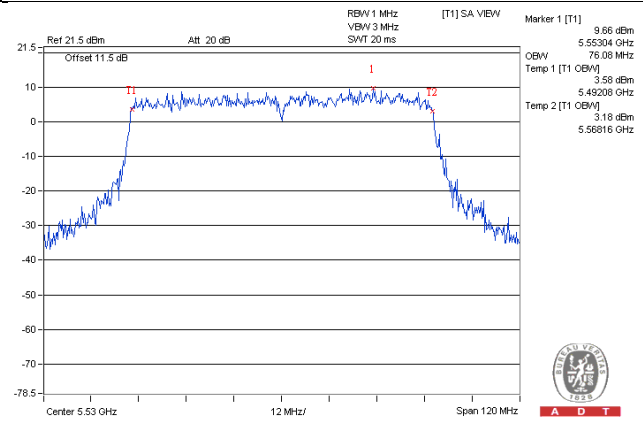

**4.6.8 Test Results (Mode 3 – 2TX)**
**802.11a**

Channel	Frequency (MHz)	Occupied Bandwidth (MHz)	
		Chain 0	Chain 1
52	5260	16.80	16.68
60	5300	16.68	16.68
64	5320	16.68	16.80
100	5500	16.80	16.80
116	5580	16.92	16.80
140	5700	16.80	16.68

**802.11ac (VHT20)**

Channel	Frequency (MHz)	Occupied Bandwidth (MHz)	
		Chain 0	Chain 1
52	5260	17.76	17.76
60	5300	17.88	18.00
64	5320	17.88	17.88
100	5500	17.88	18.00
116	5580	17.88	17.88
140	5700	18.00	17.88

**802.11ac (VHT40)**

Channel	Frequency (MHz)	Occupied Bandwidth (MHz)	
		Chain 0	Chain 1
54	5270	36.80	36.60
62	5310	36.60	36.60
102	5510	36.80	36.60
110	5550	36.60	36.60
134	5670	36.80	36.60

**802.11ac (VHT80)**

Channel	Frequency (MHz)	Occupied Bandwidth (MHz)	
		Chain 0	Chain 1
58	5290	76.08	75.84
106	5530	75.84	75.84
122	5610	76.08	75.84



Spectrum Plot of Worst Value

802.11a: Chain 0 / CH116

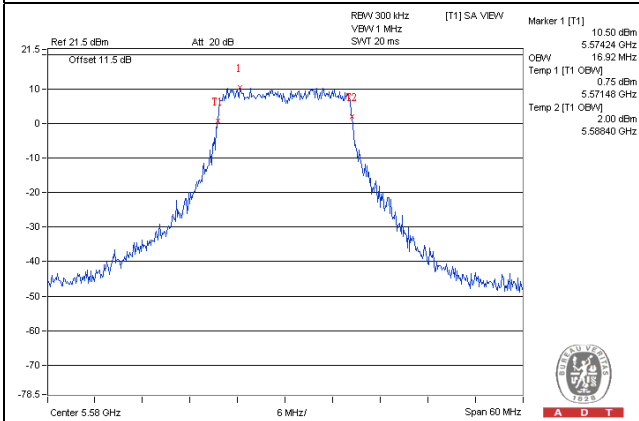

802.11ac (VHT20): Chain 1 / CH140

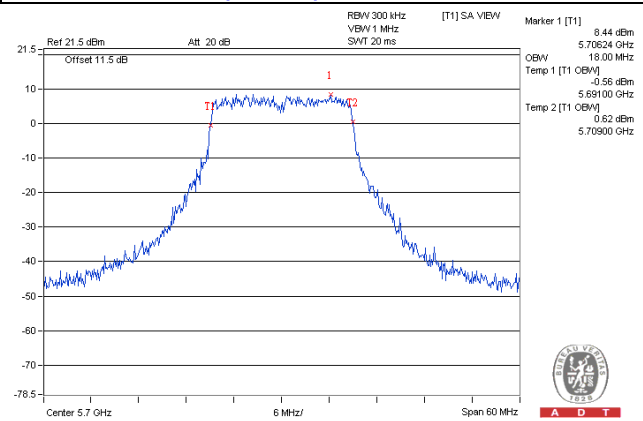

802.11ac (VHT40): Chain 0 / CH54

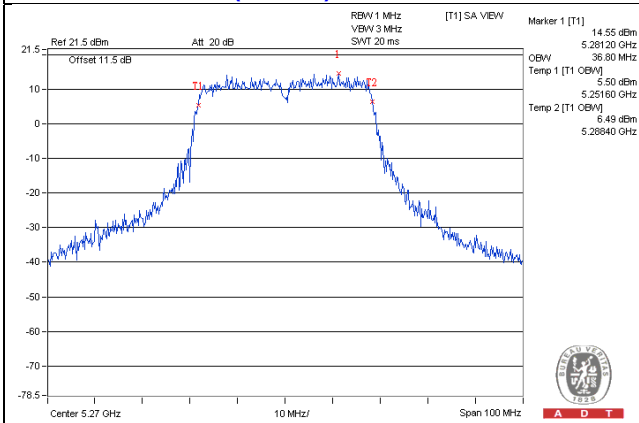

802.11ac (VHT80): Chain 0 / CH58

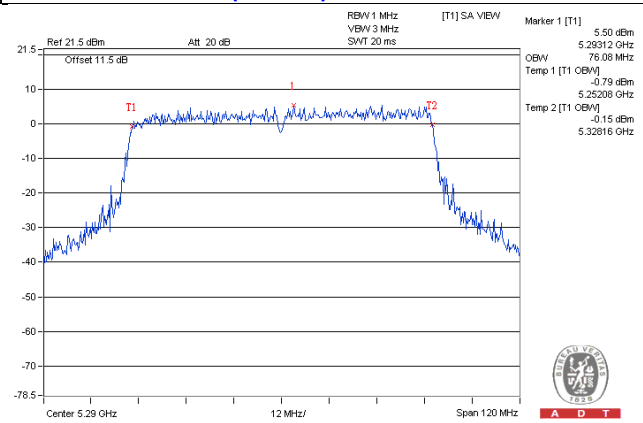

## 4.7 26dB Bandwidth Measurement

### 4.7.1 Test Setup



### 4.7.2 Test Instruments

Refer to section 4.1.2 to get information of above instrument.

### 4.7.3 Test Procedure

1. Set RBW = approximately 1% of the emission bandwidth.
2. Set the VBW > RBW.
3. Detector = Peak.
4. Trace mode = max hold.
5. Measure the maximum width of the emission that is 26 dB down from the peak of the emission. Compare this with the RBW setting of the analyzer. Readjust RBW and repeat measurement as needed until the RBW/EBW ratio is approximately 1%.

### 4.7.4 Deviation from Test Standard

No deviation.

### 4.7.5 EUT Operating Condition

The software provided by client to enable the EUT under transmission condition continuously at lowest, middle and highest channel frequencies individually.

**4.7.6 Test Results (Mode 1 – Chain 0)**
**802.11a**

Channel	Frequency (MHz)	26dB Bandwidth (MHz)
52	5260	21.84
60	5300	23.43
64	5320	22.06
100	5500	21.88
116	5580	22.53
140	5700	22.40

**802.11ac (VHT20)**

Channel	Frequency (MHz)	26dB Bandwidth (MHz)
52	5260	23.24
60	5300	23.01
64	5320	23.21
100	5500	23.07
116	5580	23.48
140	5700	23.06

**802.11ac (VHT40)**

Channel	Frequency (MHz)	26dB Bandwidth (MHz)
54	5270	47.83
62	5310	46.41
102	5510	45.17
110	5550	46.99
134	5670	47.03

**802.11ac (VHT80)**

Channel	Frequency (MHz)	26dB Bandwidth (MHz)
58	5290	88.61
106	5530	87.76
122	5610	90.74

Spectrum Plot of Worst Value

802.11a: CH52

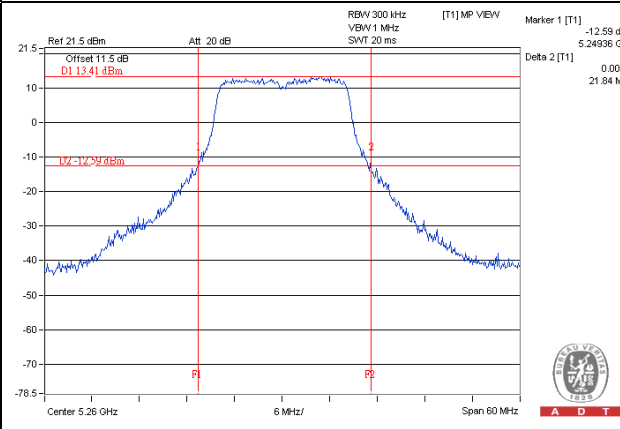

802.11ac (VHT20): CH60

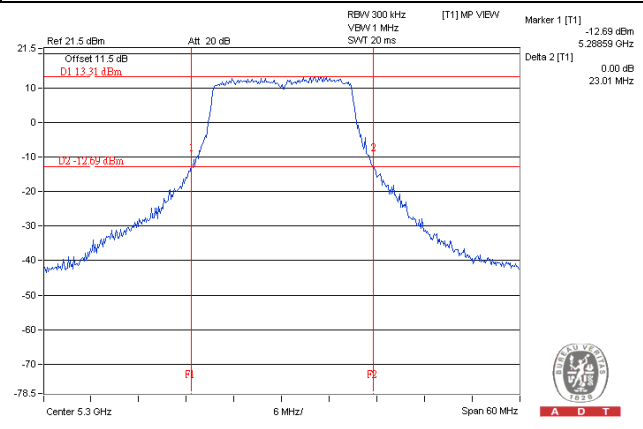

802.11ac (VHT40): CH102

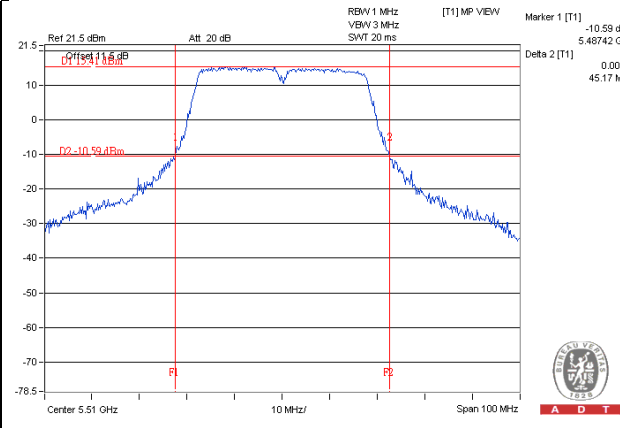

802.11ac (VHT80): CH106

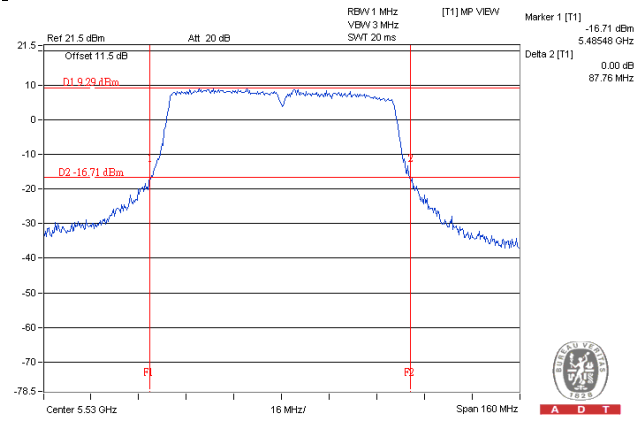

**4.7.7 Test Results (Mode 2 – Chain 1)**
**802.11a**

Channel	Frequency (MHz)	26dB Bandwidth (MHz)
52	5260	22.70
60	5300	22.90
64	5320	22.21
100	5500	22.56
116	5580	22.39
140	5700	22.54

**802.11ac (VHT20)**

Channel	Frequency (MHz)	26dB Bandwidth (MHz)
52	5260	23.23
60	5300	22.92
64	5320	23.39
100	5500	23.22
116	5580	23.89
140	5700	23.04

**802.11ac (VHT40)**

Channel	Frequency (MHz)	26dB Bandwidth (MHz)
54	5270	45.91
62	5310	45.99
102	5510	45.69
110	5550	46.80
134	5670	46.12

**802.11ac (VHT80)**

Channel	Frequency (MHz)	26dB Bandwidth (MHz)
58	5290	87.59
106	5530	88.09
122	5610	86.94

Spectrum Plot of Worst Value

802.11a: CH64

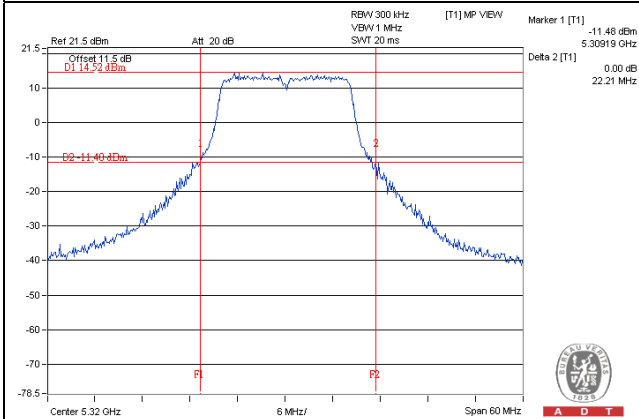

802.11ac (VHT20): CH60

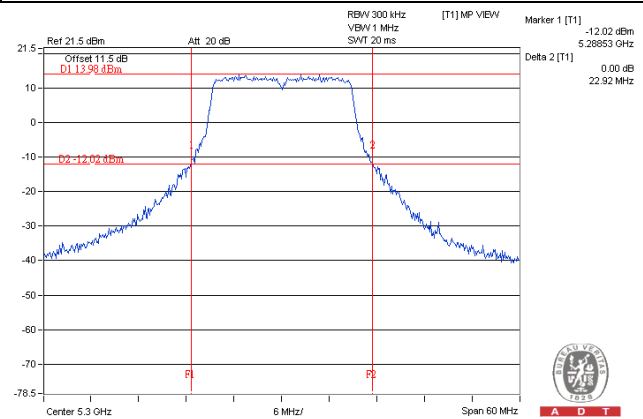

802.11ac (VHT40): CH102

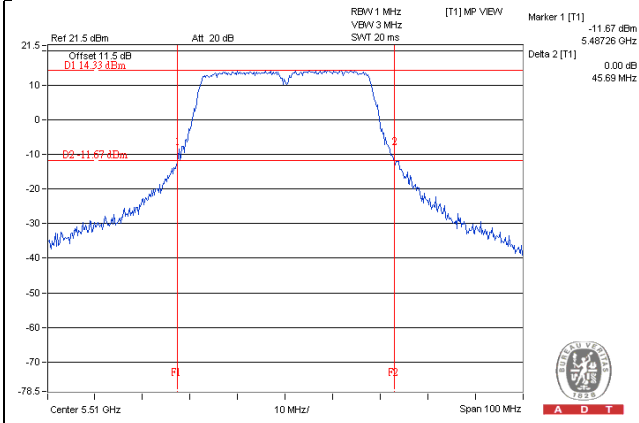

802.11ac (VHT80): CH106

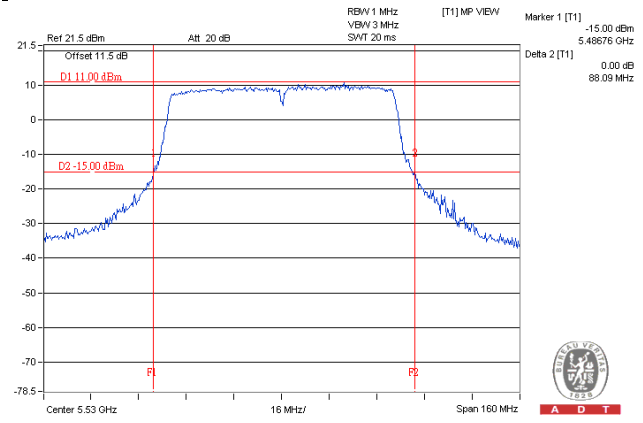

**4.7.8 Test Results (Mode 3 – 2TX)**
**802.11a**

Channel	Frequency (MHz)	26dB Bandwidth (MHz)	
		Chain 0	Chain 1
52	5260	21.84	21.36
60	5300	22.72	21.16
64	5320	22.29	21.86
100	5500	21.74	21.83
116	5580	22.05	22.21
140	5700	21.84	21.67

**802.11ac (VHT20)**

Channel	Frequency (MHz)	26dB Bandwidth (MHz)	
		Chain 0	Chain 1
52	5260	22.84	23.15
60	5300	22.97	22.62
64	5320	23.81	22.90
100	5500	23.08	22.78
116	5580	23.50	22.33
140	5700	23.44	22.60

**802.11ac (VHT40)**

Channel	Frequency (MHz)	26dB Bandwidth (MHz)	
		Chain 0	Chain 1
54	5270	46.08	45.56
62	5310	45.86	44.70
102	5510	45.49	45.27
110	5550	46.71	46.05
134	5670	46.75	44.43

**802.11ac (VHT80)**

Channel	Frequency (MHz)	26dB Bandwidth (MHz)	
		Chain 0	Chain 1
58	5290	86.80	89.26
106	5530	88.21	85.62
122	5610	90.51	86.95

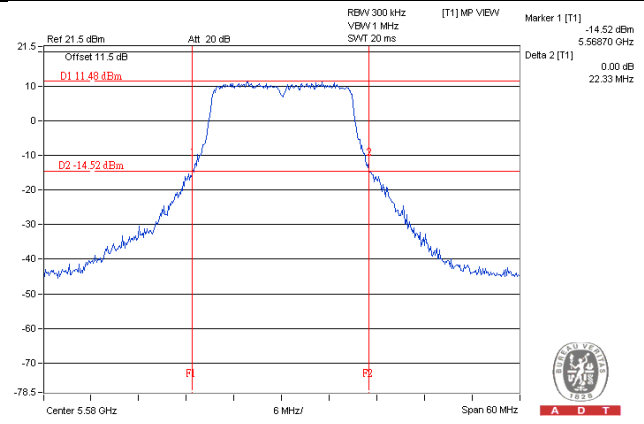
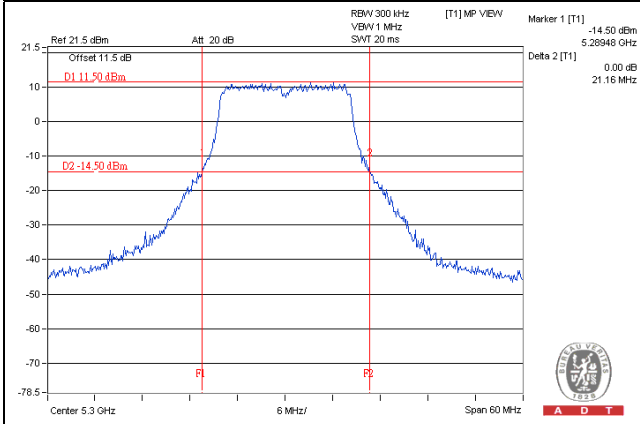
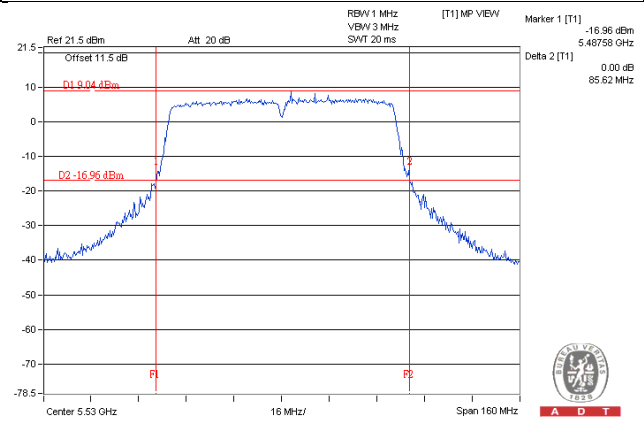
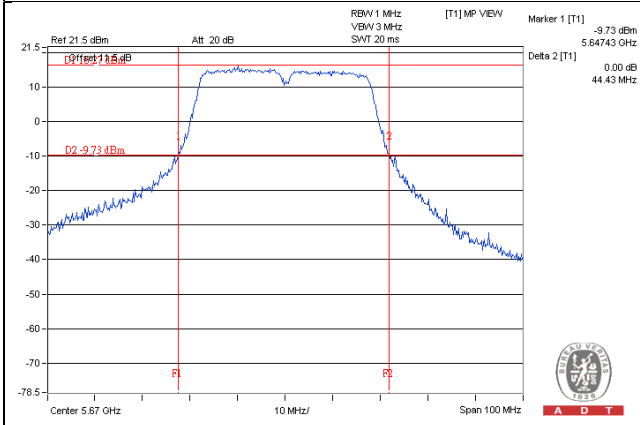
**Spectrum Plot of Worst Value****802.11a: Chain 1 / CH60****802.11ac (VHT20): Chain 1 / CH116****802.11ac (VHT40): Chain 1 / CH134****802.11ac (VHT80): Chain 1 / CH106**



## 5 Pictures of Test Arrangements

Please refer to the attached file (Test Setup Photo).



## Appendix – Information on the Testing Laboratories

We, Bureau Veritas Consumer Products Services (H.K.) Ltd., Taoyuan Branch, were founded in 1988 to provide our best service in EMC, Radio, Telecom and Safety consultation. Our laboratories are accredited and approved according to ISO/IEC 17025.

If you have any comments, please feel free to contact us at the following:

### **Linko EMC/RF Lab**

Tel: 886-2-26052180

Fax: 886-2-26051924

### **Hsin Chu EMC/RF Lab/Telecom Lab**

Tel: 886-3-6668565

Fax: 886-3-6668323

### **Hwa Ya EMC/RF/Safety**

Tel: 886-3-3183232

Fax: 886-3-3270892

**Email:** [service.adt@tw.bureauveritas.com](mailto:service.adt@tw.bureauveritas.com)

**Web Site:** [www.bureauveritas-adt.com](http://www.bureauveritas-adt.com)

The address and road map of all our labs can be found in our web site also.

--- END ---