



MEASUREMENT REPORT

FCC PART 15.407 / RSS-247 WLAN 802.11a/n/ac

FCC ID: 2AD8UFZCWI2A1
IC: 109D-FZCWI2A01
APPLICANT: Nokia Solutions and Networks

Application Type: Certification
Product: Wireless Access Point
Model No.: WI2A-AC200i
Brand Name: NOKIA
FCC Classification: Unlicensed National Information Infrastructure (UNII)
FCC Rule Part(s): Part 15.407
IC Rule(s): RSS-247 Issue 1
Test Procedure(s): ANSI C63.10-2013, KDB 789033 D02v01,
KDB 662911 D01v02r01, KDB 644545 D03v01
Test Date: June 16 ~ August 18, 2015

Reviewed By : Robin Wu
(Robin Wu)

Approved By : Marlin Chen
(Marlin Chen)



The test results relate only to the samples tested.

This equipment has been shown to be capable of compliance with the applicable technical standards as indicated in the measurement report and was tested in accordance with the measurement procedures specified in KDB 789033 D02v01. Test results reported herein relate only to the item(s) tested.

The test report shall not be reproduced except in full without the written approval of MRT Technology (Suzhou) Co., Ltd.

Revision History

Report No.	Version	Description	Issue Date
1506RSU00616	Rev. 01	Initial report	11-10-2015

CONTENTS

Description	Page
§2.1033 General Information	6
1. INTRODUCTION	7
1.1. Scope	7
1.2. MRT Test Location	7
2. PRODUCT INFORMATION	8
2.1. Equipment Description.....	8
2.2. Working Frequencies for this report	10
2.3. Description of Available Antennas.....	12
2.4. Description of Antenna RF Port	13
2.5. Test Mode	13
2.6. Test Software.....	13
2.7. Device Capabilities	14
2.8. Test Configuration	16
2.9. EMI Suppression Device(s)/Modifications.....	16
2.10. Labeling Requirements.....	16
3. DESCRIPTION OF TEST	17
3.1. Evaluation Procedure	17
3.2. AC Line Conducted Emissions	17
3.3. Radiated Emissions	18
4. ANTENNA REQUIREMENTS.....	19
5. TEST EQUIPMENT CALIBRATION DATE	20
6. MEASUREMENT UNCERTAINTY.....	21
7. TEST RESULT	22
7.1. Summary	22
7.2. 26dB Bandwidth Measurement.....	25
7.2.1. Test Limit	25
7.2.2. Test Procedure used.....	25
7.2.3. Test Setting.....	25
7.2.4. Test Setup	25
7.2.5. Test Result.....	26
7.3. 6dB Bandwidth Measurement.....	60
7.3.1. Test Limit	60
7.3.2. Test Procedure used.....	60

7.3.3. Test Setting.....	60
7.3.4. Test Setup	60
7.3.5. Test Result.....	61
7.4. Operation Frequency Range of 26dBc Bandwidth Measurement.....	70
7.4.1. Test Limit	70
7.4.2. Test Procedure used.....	70
7.4.3. Test Setting.....	70
7.4.4. Test Setup	70
7.4.5. Test Result.....	71
7.5. Output Power Measurement.....	74
7.5.1. Test Limit	74
7.5.2. Test Procedure Used	75
7.5.3. Test Setting.....	75
7.5.4. Test Setup	75
7.5.5. Test Result.....	76
7.6. Transmit Power Control	95
7.6.1. Test Limit	95
7.6.2. Test Procedure Used	95
7.6.3. Test Setting.....	95
7.6.4. Test Setup	95
7.6.5. Test Result.....	96
7.7. Power Spectral Density Measurement	102
7.7.1. Test Limit	102
7.7.2. Test Procedure Used	102
7.7.3. Test Setting.....	103
7.7.4. Test Setup	103
7.7.5. Test Result.....	104
7.8. Frequency Stability Measurement.....	187
7.8.1. Test Limit	187
7.8.2. Test Procedure Used	187
7.8.3. Test Setup	187
7.8.4. Test Result.....	188
7.9. Radiated Spurious Emission Measurement	189
7.9.1. Test Limit	189
7.9.2. Test Procedure Used	189
7.9.3. Test Setting.....	189
7.9.4. Test Setup	190
7.9.5. Test Result.....	192
7.10. Radiated Restricted Band Edge Measurement	399

7.10.1. Test Limit	399
7.10.2. Test Result of Radiated Restricted Band Edge	403
7.11. AC Conducted Emissions Measurement.....	811
7.11.1. Test Limit	811
7.11.2. Test Procedure	811
7.11.3. Test Setup	812
7.11.4. Test Result.....	813
8. CONCLUSION.....	815

§2.1033 General Information

Applicant:	Nokia Solutions and Networks
Applicant Address:	Karaportti 3, P.O. Box 226, FI-00045 Nokia Group, Finland
Manufacturer:	Nokia Solutions and Networks
Manufacturer Address:	Karaportti 3, P.O. Box 226, FI-00045 Nokia Group, Finland
Test Site:	MRT Technology (Suzhou) Co., Ltd
Test Site Address:	D8 Building, Youxin Industrial Park, No.2 Tian'edang Rd., Wuzhong Economic Development Zone, Suzhou, China
FCC Registration No.:	809388
IC Registration No.:	11384A
FCC Rule Part(s):	Part 15.247
IC Rule(s):	RSS-247
Model No.:	WI2A-AC200i
Test Device Serial No.:	N/A <input type="checkbox"/> Production <input checked="" type="checkbox"/> Pre-Production <input type="checkbox"/> Engineering
FCC Classification:	Unlicensed National Information Infrastructure (UNII)

Test Facility / Accreditations

Measurements were performed at MRT Laboratory located in Tian'edang Rd., Suzhou, China.

- MRT facility is a FCC registered (MRT Reg. No. 809388) test facility with the site description report on file and has met all the requirements specified in Section 2.948 of the FCC Rules.
- MRT facility is an IC registered (MRT Reg. No. 11384A-1) test laboratory with the site description on file at Industry Canada.
- MRT facility is a VCCI registered (R-4179, G-814, C-4664, T-2206) test laboratory with the site description on file at VCCI Council.
- MRT Lab is accredited to ISO 17025 by the American Association for Laboratory Accreditation (A2LA) under the American Association for Laboratory Accreditation Program (A2LA Cert. No. 3628.01) in EMC, Telecommunications and Radio testing for FCC, Industry Canada, EU and TELEC Rules.



1. INTRODUCTION

1.1. Scope

Measurement and determination of electromagnetic emissions (EMC) of radio frequency devices including intentional and/or unintentional radiators for compliance with the technical rules and regulations of the Federal Communications Commission and the Industry Canada Certification and Engineering Bureau.

1.2. MRT Test Location

The map below shows the location of the MRT LABORATORY, its proximity to the Taihu Lake. These measurement tests were conducted at the MRT Technology (Suzhou) Co., Ltd. Facility located at D8 Building, Youxin Industrial Park, No.2 Tian'edang Rd., Wuzhong Economic Development Zone, Suzhou, China. The detailed description of the measurement facility was found to be in compliance with the requirements of § 2.948 according to ANSI C63.4-2009 on September 30, 2013.



2. PRODUCT INFORMATION

2.1. Equipment Description

Product Name	Wireless Access Point
Model No.	WI2A-AC200i
Brand Name	Nokia
Hardware Version	v2.0
Frequency Range	<p><u>2.4GHz:</u></p> <p>For 802.11b/g/n-HT20: 2412 ~ 2462 MHz</p> <p>For 802.11n-HT40: 2422 ~ 2452 MHz</p> <p><u>5GHz:</u></p> <p>For 802.11a/n-HT20: 5180~5320MHz, 5500~5700MHz, 5745~5825MHz</p> <p>For 802.11ac-VHT20: 5180~5320MHz, 5500~5720MHz, 5745~5825MHz</p> <p>For 802.11n-HT40: 5190~5310MHz, 5510~5670MHz, 5755~5795MHz</p> <p>For 802.11ac-VHT40: 5190~5310MHz, 5510~5710MHz, 5755~5795MHz</p> <p>For 802.11ac-VHT80: 5210MHz, 5290MHz, 5530MHz, 5610MHz, 5690MHz, 5775MHz</p>
Maximum Output Power	<p>802.11a: 26.29dBm</p> <p>802.11n-HT20: 26.09dBm</p> <p>802.11n-HT40: 25.98dBm</p> <p>802.11ac-VHT20: 26.18dBm</p> <p>802.11ac-VHT40: 26.00dBm</p> <p>802.11ac-VHT80: 21.78dBm</p>
Type of Modulation	802.11a/n/ac: OFDM
Components	
Adapter	<p>M/N: DSA-12CA-12 120100</p> <p>Input: 100-240V ~ 50/60Hz, 0.3A</p> <p>OUTPUT: 12Vdc, 1A</p>
POE	<p>M/N: PoE35-54A</p> <p>Input: 100-240V ~ 50/60Hz, 1A</p> <p>OUTPUT: 54Vdc, 0.65A</p>

Note 1: For all of the test mode, two power supplies have been assessed in the spurious emission

test, and showed the worst test data for AC Adpter (DSA-12CA-12 120100) in the test report.

Note 2: The change of the measured voltage at the radio part of the EUT is below $\pm 1\%$, when input voltage from external power supply (AC Adapter & POE Adapter) to the equipment under test, thus the RF test is tested with AC Adapter only.

AC Adapter Voltage	3.30V
POE Adapter Voltage	3.31V

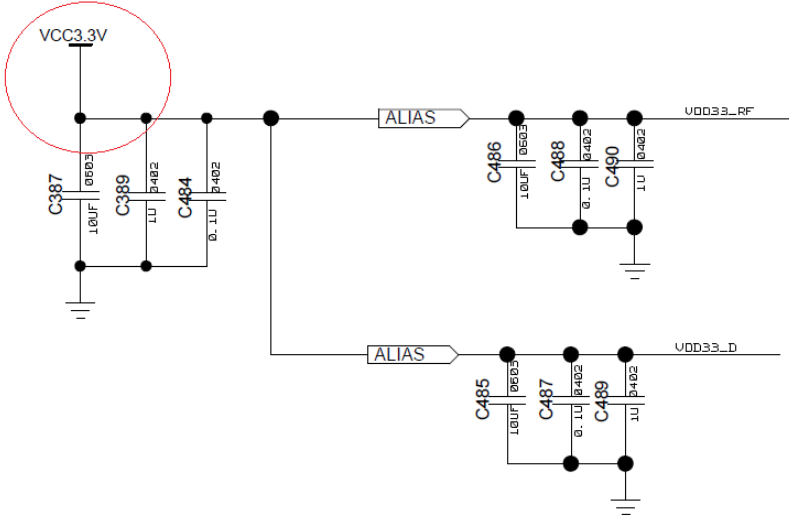

The diagram illustrates the power supply network for the equipment under test. It shows three main power rails: VCC3.3V, VDD33_RF, and VDD33_D. The VCC3.3V rail is highlighted with a red circle. Each rail is connected to a common power source through an 'ALIAS' component. The VCC3.3V rail includes capacitors C387 (10uF), C389 (1uF), and C484 (0.1uF). The VDD33_RF rail includes capacitors C486 (10uF), C488 (0.1uF), and C490 (1uF). The VDD33_D rail includes capacitors C485 (10uF), C487 (0.1uF), and C489 (1uF).

2.2. Working Frequencies for this report

802.11a/n-HT20

Channel	Frequency	Channel	Frequency	Channel	Frequency
36	5180 MHz	40	5200 MHz	44	5220 MHz
48	5240 MHz	52	5260 MHz	56	5280 MHz
60	5300 MHz	64	5320 MHz	100	5500 MHz
104	5520 MHz	108	5540 MHz	112	5560 MHz
116	5580 MHz	120	5600 MHz	124	5620 MHz
128	5640 MHz	132	5660 MHz	136	5680 MHz
140	5700 MHz	149	5745 MHz	153	5765 MHz
157	5785 MHz	161	5805 MHz	165	5825 MHz

802.11ac-VHT20

Channel	Frequency	Channel	Frequency	Channel	Frequency
36	5180 MHz	40	5200 MHz	44	5220 MHz
48	5240 MHz	52	5260 MHz	56	5280 MHz
60	5300 MHz	64	5320 MHz	100	5500 MHz
104	5520 MHz	108	5540 MHz	112	5560 MHz
116	5580 MHz	120	5600 MHz	124	5620 MHz
128	5640 MHz	132	5660 MHz	136	5680 MHz
140	5700 MHz	144	5720 MHz	149	5745 MHz
153	5765 MHz	157	5785 MHz	161	5805 MHz
165	5825 MHz	--	--	--	--

802.11n-HT40

Channel	Frequency	Channel	Frequency	Channel	Frequency
38	5190 MHz	46	5230 MHz	54	5270 MHz
62	5310 MHz	102	5510 MHz	110	5550 MHz
118	5590 MHz	126	5630 MHz	134	5670 MHz
151	5755 MHz	159	5795 MHz	--	--

802.11ac-VHT40

Channel	Frequency	Channel	Frequency	Channel	Frequency
38	5190 MHz	46	5230 MHz	54	5270 MHz
62	5310 MHz	102	5510 MHz	110	5550 MHz
118	5590 MHz	126	5630 MHz	134	5670 MHz
142	5710 MHz	151	5755 MHz	159	5795 MHz

802.11ac-VHT80

Channel	Frequency	Channel	Frequency	Channel	Frequency
42	5210 MHz	58	5290 MHz	106	5530 MHz
122	5610 MHz	138	5690 MHz	155	5775 MHz

Note: The device can't operate in 5600~5650 MHz band in Canada (The frequency of blue font).

2.3. Description of Available Antennas

Antenna Type	Frequency Band (MHz)	Tx Paths	Per Chain Max Antenna Gain (dBi)		Beam Forming Directional Gain (dBi)	CDD Directional Gain (dBi)
			Ant 1	Ant 2		
PCB Antenna	2412 ~2462	2	3.23	2.38	5.83	5.83
	5150 ~ 5250	2	5.40	4.53	7.99	7.99
	5250 ~ 5350	2	5.50	4.81	8.17	8.17
	5470 ~ 5725	2	5.89	5.97	8.94	8.94
	5725 ~ 5850	2	6.00	5.86	8.94	8.94

1. The EUT supports Cyclic Delay Diversity (CDD) technology for 802.11a/b/g mode, and CDD signals are correlated.
2. The EUT supports Beam Forming technology for 802.11n/ac mode, and exclude 802.11b/g mode.

Correlated signals include, but are not limited to, signals transmitted in any of the following modes:

- Unequal Antenna gains, with equal transmit powers. For Antenna gains given by G_1, G_2, \dots, G_N dBi transmit signals are correlated, then
- Directional gain = $10 \cdot \log[(10^{G_1/20} + 10^{G_2/20} + \dots + 10^{G_N/20})^2 / N_{ANT}]$ dBi [Note the “20”s in the denominator of each exponent and the square of the sum of terms; the object is to combine the signal levels coherently.]

For example: 5250 ~ 5350MHz Directional Gain = $10 \cdot \log[(10^{5.50/20} + 10^{4.81/20})^2 / 2] = 8.17$ dBi

2.4. Description of Antenna RF Port

Antenna RF Port				
--	2.4GHz RF Port		5GHz RF Port	
	2.4GHz-1	2.4GHz-2	5GHz-1	5GHz-2
Software Control Port	Ant 1	Ant 2	Ant 1	Ant 2

The photograph shows a green printed circuit board (PCB) with a silver antenna array. Two red circles are drawn around the antenna ports. Red text labels with arrows point to these circles: '2.4GHz & 5GHz Ant Port #1' points to the lower circle, and '2.4GHz & 5GHz Ant Port #2' points to the upper circle. The PCB also has some other components and a small white label with the number '21-15200-240'.

2.5. Test Mode

Test Mode	Mode 1: Transmit by 802.11a
	Mode 2: Transmit by 802.11n-HT20
	Mode 3: Transmit by 802.11n-HT40
	Mode 4: Transmit by 802.11ac-VHT20
	Mode 5: Transmit by 802.11ac-VHT40
	Mode 6: Transmit by 802.11ac-VHT80

2.6. Test Software

The test utility software used during testing was “ART2-GUI Version: 2.3”.

2.7. Device Capabilities

This device contains the following capabilities:

2.4GHz WLAN (DTS) and 5GHz WLAN (NII).

Note: 5GHz (NII) operation is possible in 20MHz, 40MHz and 80MHz channel bandwidths. The maximum achievable duty cycles for all modes were determined based on measurements performed on a spectrum analyzer in zero-span mode with RBW = 8MHz, VBW = 50MHz, and detector = average per the guidance of Section B)2)b) of KDB 789033 D02v01. The RBW and VBW were both greater than 50/T, where T is the minimum transmission duration, and the number of sweep points across T was greater than 100. The duty cycles are as follows:

Test Mode	Duty Cycle
802.11a	96.04 %
802.11n-HT20	93.72 %
802.11n-HT40	91.16 %
802.11ac-VHT20	95.63 %
802.11ac-VHT40	90.35 %
802.11ac-VHT80	82.45 %

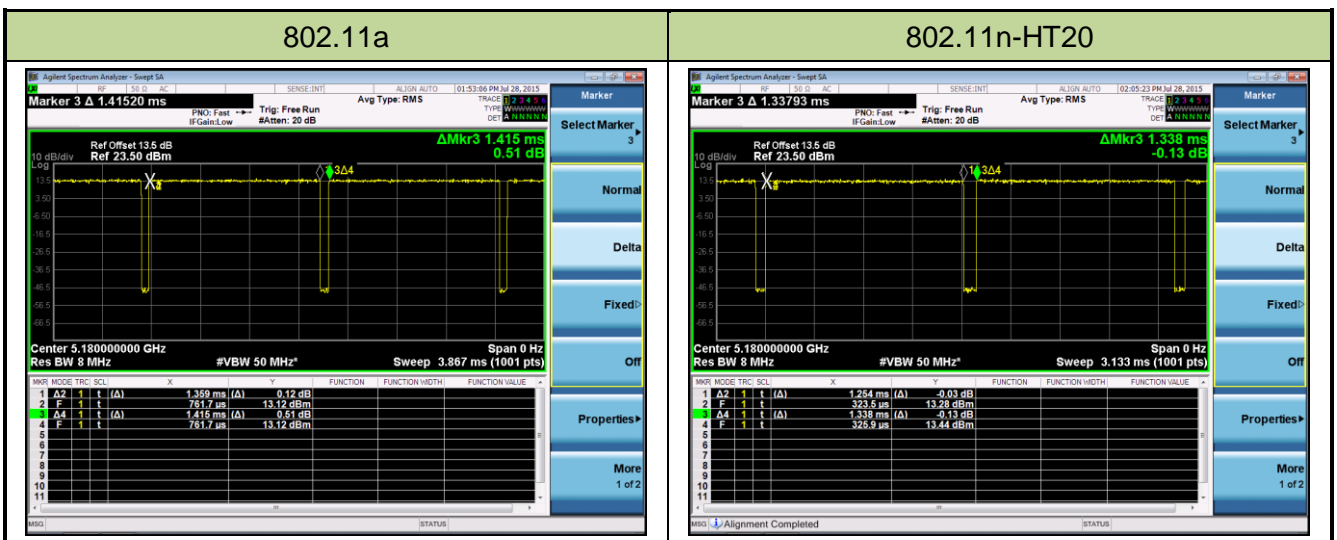

802.11n-HT40

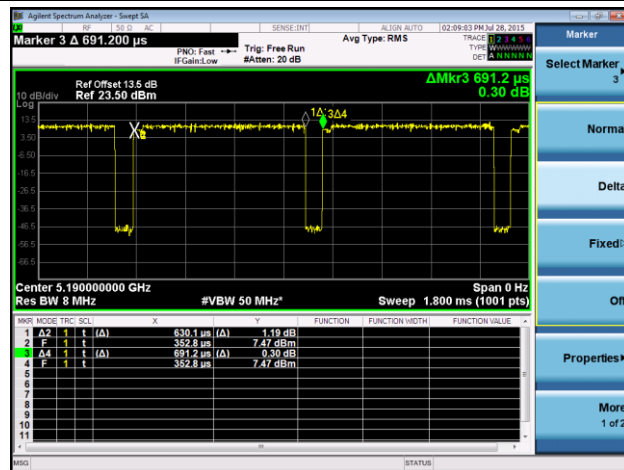

802.11ac-VHT20

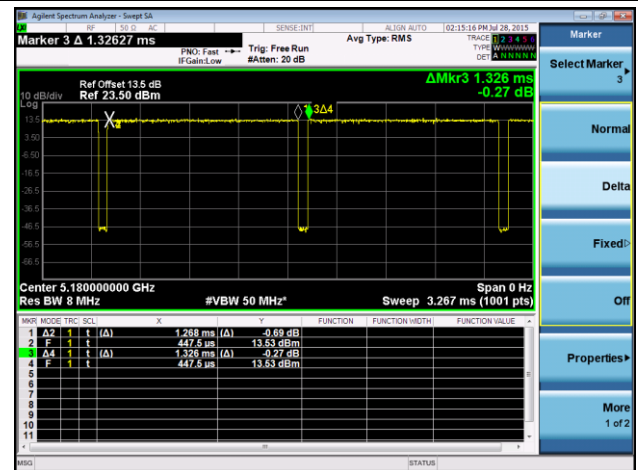

802.11ac-VHT40

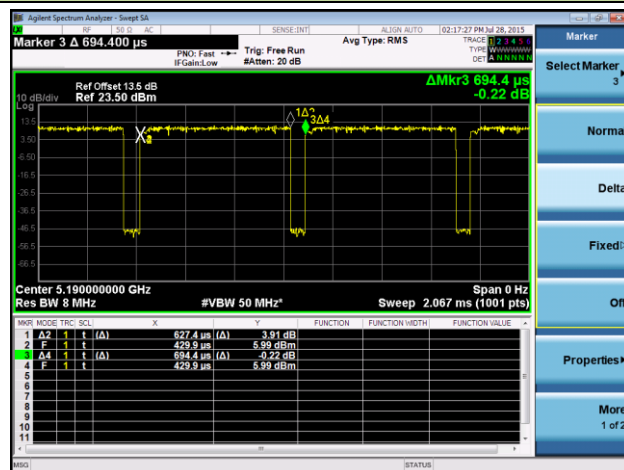

802.11ac-VHT80

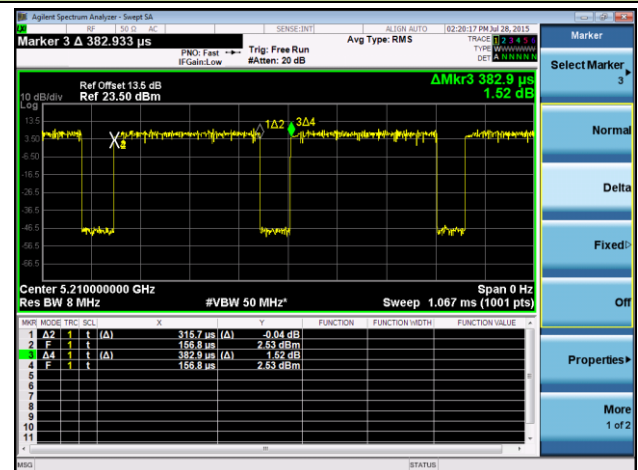

2.8. Test Configuration

The **Wireless Access Point FCC ID: 2AD8UFZCW12A1, Model Number: W12A-AC200i** was tested per the guidance of KDB 789033 D02v01. ANSI C63.10-2013 was used to reference the appropriate EUT setup for radiated spurious emissions testing and AC line conducted testing.

2.9. EMI Suppression Device(s)/Modifications

No EMI suppression device(s) were added and/or no modifications were made during testing.

2.10. Labeling Requirements

Per 2.1074 & 15.19; Docket 95-19

The label shall be permanently affixed at a conspicuous location on the device; instruction manual or pamphlet supplied to the user and be readily visible to the purchaser at the time of purchase.

However, when the device is so small wherein placement of the label with specified statement is not practical, only the trade name and FCC ID must be displayed on the device per Section 15.19(a)(5).

Please see attachment for FCC ID label and label location.

3. DESCRIPTION OF TEST

3.1. Evaluation Procedure

The measurement procedures described in the American National Standard for Testing Unlicensed Wireless Devices (ANSI C63.10-2013), and the guidance provided in KDB 789033 D02v01 were used in the measurement of the **Wireless Access Point FCC ID: 2AD8UFZCW12A1, Model Number: W12A-AC200i.**

Deviation from measurement procedure.....None

3.2. AC Line Conducted Emissions

The line-conducted facility is located inside an 8'x4'x4' shielded enclosure. A 1m x 2m wooden table 80cm high is placed 40cm away from the vertical wall and 80cm away from the sidewall of the shielded room. Two 10kHz-30MHz, 50Ω/50uH Line-Impedance Stabilization Networks (LISNs) are bonded to the shielded room floor. Power to the LISNs is filtered by external high-current high-insertion loss power line filters. These filters attenuate ambient signal noise from entering the measurement lines. These filters are also bonded to the shielded enclosure.

The EUT is powered from one LISN and the support equipment is powered from the second LISN. All interconnecting cables more than 1 meter were shortened to a 1 meter length by non-inductive bundling (serpentine fashion) and draped over the back edge of the test table. All cables were at least 40cm above the horizontal reference ground-plane. Power cables for support equipment were routed down to the second LISN while ensuring that that cables were not draped over the second LISN.

Sufficient time for the EUT, support equipment, and test equipment was allowed in order for them to warm up to their normal operating condition. The RF output of the LISN was connected to the receiver and exploratory measurements were made to determine the frequencies producing the maximum emission from the EUT. The receiver was scanned from 150kHz to 30MHz. The detector function was set to peak mode for exploratory measurements while the bandwidth of the analyzer was set to 9kHz. The EUT, support equipment, and interconnecting cables were arranged and manipulated to maximize each emission. Each emission was also maximized by varying: power lines, the mode of operation or data exchange speed, or support equipment whichever determined the worst-case emission. Once the worst case emissions have been identified, the one EUT cable configuration/arrangement and mode of operation that produced these emissions are used for final measurements on the same test site. The analyzer is set to CISPR quasi-peak and average detectors with a 9kHz resolution bandwidth for final measurements.

An extension cord was used to connect to a single LISN which powered by EUT. The extension cord was calibrated with LISN, the impedance and insertion loss are compliance with the requirements as stated in ANSI C63.10-2013.

Line conducted emissions test results are shown in Section 7.10.

3.3. Radiated Emissions

The radiated test facilities consisted of an indoor 3 meter semi-anechoic chamber used for final measurements and exploratory measurements, when necessary. The measurement area is contained within the semi-anechoic chamber which is shielded from any ambient interference. For measurements above 1GHz absorbers are arranged on the floor between the turn table and the antenna mast in such a way so as to maximize the reduction of reflections. For measurements below 1GHz, the absorbers are removed. A MF Model 210SS turntable is used for radiated measurement. It is a continuously rotatable, remote controlled, metallic turntable and 2 meters (6.56 ft.) in diameter. The turn table is flush with the raised floor of the chamber in order to maintain its function as a ground plane. An 80cm high PVC support structure is placed on top of the turntable.

For all measurements, the spectrum was scanned through all EUT azimuths and from 1 to 4 meter receive antenna height using a broadband antenna from 30MHz up to the upper frequency shown in 15.33(b)(1) depending on the highest frequency generated or used in the device or on which the device operates or tunes. For frequencies above 1GHz, linearly polarized double ridge horn antennas were used. For frequencies below 30MHz, a calibrated loop antenna was used. When exploratory measurements were necessary, they were performed at 1 meter test distance inside the semi-anechoic chamber using broadband antennas, broadband amplifiers, and spectrum analyzers to determine the frequencies and modes producing the maximum emissions. Sufficient time for the EUT, support equipment, and test equipment was allowed in order for them to warm up to their normal operating condition. The test set-up for frequencies below 1GHz was placed on top of the 0.8 meter high, 1 x 1.5 meter table; and test set-up for frequencies 1-40GHz was placed on top of the 1.5 meter high, 1 x 1.5 meter table. The EUT, support equipment, and interconnecting cables were arranged and manipulated to maximize each emission. Appropriate precaution was taken to ensure that all emissions from the EUT were maximized and investigated. The system configuration, clock speed, mode of operation or video resolution, if applicable, turntable azimuth, and receive antenna height was noted for each frequency found.

Final measurements were made in the semi-anechoic chamber using calibrated, linearly polarized broadband and horn antennas. The test setup was configured to the setup that produced the worst case emissions. The spectrum analyzer was set to investigate all frequencies required for testing to compare the highest radiated disturbances with respect to the specified limits. The turntable containing the EUT was rotated through 360 degrees and the height of the receive antenna was varied 1 to 4 meters and stopped at the azimuth and height producing the maximum emission. Each emission was maximized by changing the orientation of the EUT through three orthogonal planes and changing the polarity of the receive antenna, whichever produced the worst-case emissions. According to 3dB Beam-Width of horn antenna, the horn antenna should be always directed to the EUT when rising height.

4. ANTENNA REQUIREMENTS

Excerpt from §15.203 of the FCC Rules/Regulations:

“An intentional radiator antenna shall be designed to ensure that no antenna other than that furnished by the responsible party can be used with the device. The use of a permanently attached antenna or of an antenna that uses a unique coupling to the intentional radiator shall be considered sufficient to comply with the provisions of this section.”

- The antenna of **Wireless Access Point** is **permanently attached**.
- There are no provisions for connection to an external antenna.

Conclusion:

The **Wireless Access Point FCC ID: 2AD8UFZCW12A1, Model Number: W12A-AC200i** unit complies with the requirement of §15.203.

5. TEST EQUIPMENT CALIBRATION DATE

Conducted Emissions – TR1

Instrument	Manufacturer	Type No.	Asset No.	Cali. Interval	Cali. Due Date
EMI Test Receiver	R&S	ESR7	MRTSUE06001	1 year	2015/11/07
Two-Line V-Network	R&S	ENV216	MRTSUE06002	1 year	2015/11/07
Two-Line V-Network	R&S	ENV216	MRTSUE06003	1 year	2015/11/07
Temperature/Humidity Meter	Ouleinuo	N/A	MRTSUE06114	1 year	2015/11/20

Radiated Emissions – AC 1

Instrument	Manufacturer	Type No.	Asset No.	Cali. Interval	Cali. Due Date
Spectrum Analyzer	Agilent	E4447A	MRTSUE06028	1 year	2015/10/09
EMI Test Receiver	R&S	ESR7	MRTSUE06001	1 year	2015/11/07
Preamplifier	Agilent	83017A	MRTSUE06020	1 year	2015/12/13
Preamplifier	Schwarzbeck	BBV9721	MRTSUE06121	1 year	2016/04/15
Loop Antenna	Schwarzbeck	FMZB1519	MRTSUE06025	1 year	2015/11/08
TRILOG Antenna	Schwarzbeck	VULB9162	MRTSUE06022	1 year	2015/11/08
Broad-Band Horn Antenna	Schwarzbeck	BBHA9120D	MRTSUE06023	1 year	2015/11/08
Broadband Horn Antenna	Schwarzbeck	BBHA9170	MRTSUE06024	1 year	2016/01/05
Temperature/Humidity Meter	Ouleinuo	N/A	MRTSUE06115	1 year	2015/11/20

Conducted Test Equipment – TR3

Instrument	Manufacturer	Type No.	Asset No.	Cali. Interval	Cali. Due Date
Spectrum Analyzer	Agilent	N9020A	MRTSUE06106	1 year	2016/04/23
USB Wideband Power Sensor	Boonton	55006	MRTSUE06109	1 year	2015/10/15
Temperature/Humidity Meter	Ouleinuo	N/A	MRTSUE06112	1 year	2015/11/20

Software	Version	Function
e3	V 8.3.5	EMI Test Software

6. MEASUREMENT UNCERTAINTY

Where relevant, the following test uncertainty levels have been estimated for tests performed on the EUT as specified in CISPR 16-4-2. This uncertainty represents an expanded uncertainty expressed at approximately the 95% confidence level using a coverage factor of $k = 2$.

AC Conducted Emission Measurement
Measuring Uncertainty for a Level of Confidence of 95% ($U=2Uc(y)$): 150kHz~30MHz: 3.46dB
Radiated Emission Measurement
Measuring Uncertainty for a Level of Confidence of 95% ($U=2Uc(y)$): 9kHz ~ 1GHz: 4.18dB 1GHz ~ 40GHz: 4.76dB

7. TEST RESULT

7.1. Summary

Company Name: Nokia Solutions and Networks
FCC ID: 2AD8UFZCW12A1
IC: 109D-FZCW12A01
Model No.: W12A-AC200i
Data Rate(s) Tested: 6Mbps ~ 54Mbps (a);
6.5/7.2Mbps ~ 130/144.4Mbps (n-HT20MHz BW);
13.5/15.0Mbps ~ 270/300Mbps (n-HT40MHz BW);
6.5/7.2Mbps ~ 156/173.4Mbps (ac-VHT20MHz BW);
13.5/15.0Mbps ~ 360/400Mbps (ac-VHT40MHz BW);
29.3/32.5Mbps ~ 780/866.6Mbps (ac-VHT80MHz BW)

FCC Section(s)	Test Description	Test Limit	Test Condition	Test Result	Reference
15.407(a)	26dB Bandwidth	N/A	Conducted	Pass	Section 7.2
15.407(e)	6dB Bandwidth	≥ 500kHz		Pass	Section 7.3
15.407(a)(1)(ii), (2), (3)	Maximum Conducted Output Power	≤ 30 dBm U-NII-1 ≤ 24 dBm U-NII-2A ≤ 24 dBm U-NII-2C ≤ 30 dBm U-NII-3		Pass	Section 7.5
15.407(h)(1)	Transmit Power Control	≤ 24 dBm		Pass	Section 7.6
15.407(a)(1)(ii), (2), (3), (5)	Peak Power Spectral Density	≤ 17 dBm/MHz U-NII-1 ≤ 11 dBm/MHz U-NII-2A ≤ 11 dBm/MHz U-NII-2C ≤ 30 dBm/500kHz U-NII-3		Pass	Section 7.7
15.407(g)	Frequency Stability	N/A		Pass	Section 7.8
15.407(b)(1), (2), (3), (4)	Undesirable Emissions	≤ -27dBm/MHz EIRP ≤ -17dBm/MHz EIRP		Radiated	Pass
15.205, 15.209 15.407(b)(5), (6), (7)	General Field Strength Limits (Restricted Bands and Radiated Emission Limits)	Emissions in restricted bands must meet the radiated limits detailed in 15.209	Pass		
15.207	AC Conducted Emissions 150kHz - 30MHz	< FCC 15.207 limits	Line Conducted		Pass

RSS Section(s)	Test Description	Test Limit	Test Condition	Test Result	Reference
RSS-247 §6.2	99% Bandwidth	N/A	Conducted	Pass	Section 7.2
RSS-247 §6.2.4	6dB Bandwidth	>500kHz		Pass	Section 7.3
RSS-247 §6.2.1	Operation Frequency Range of 26dB BW	26dBc frequency range above 5250MHz		Pass	Section 7.4
RSS-247 §6.2.1, §6.2.2, §6.2.3, §6.2.4	Max Conducted Output Power	5250~5250, 5470~5725MHz ≤ 250 mW or 11 + 10 log ₁₀ (99% B) 5725~5850MHz, ≤ 30 dBm		Pass	Section 7.5
	Maximum E.I.R.P	5150~5250MHz ≤ 23 dBm or 10 + 10 log ₁₀ (99% B) 5250~5250, 5470~5725MHz ≤ 30 dBm or 17 + 10 log ₁₀ (99% B)			
RSS-247 §6.2.2, §6.2.3	Transmit Power Control	≤ 24 dBm		Pass	Section 7.6
RSS-247 §6.2.1, §6.2.2, §6.2.3, §6.2.4	Peak Power Spectral Density	5150~5250MHz ≤ 10 dBm/MHz 5250~5250, 5470~5725MHz ≤ 11 dBm/MHz 5725~5850MHz ≤ 30 dBm/500kHz		Pass	Section 7.7
RSS-Gen [8.11]	Frequency Stability	N/A	Pass	Section 7.8	
RSS-247 §6.2.1, §6.2.2, §6.2.3, §6.2.4	Out-of-Band Emissions	≤ -27dBm/MHz EIRP ≤ -17dBm/MHz EIRP	Radiated	Pass	Section 7.9 & 7.10
RSS-247 §6.2.1, §6.2.2, §6.2.3, §6.2.4	General Field Strength Limits (Restricted Bands and Radiated Emission Limits)	Emissions in restricted bands must meet the radiated limits detailed in RSS-Gen [8.9]		Pass	
RSS-Gen [8.8]	AC Conducted Emissions 150kHz - 30MHz	< RSS-Gen [8.8] limits	Line Conducted	Pass	Section 7.11

Notes:

- 1) All channels, modes, and modulations/data rates were investigated among all UNII bands. For radiated emission test, every axis (X, Y, Z) was also verified. The test results shown in the following sections represent the worst case emissions.
- 2) The analyzer plots shown in this section were all taken with a correction table loaded into the analyzer. The correction table was used to account for the losses of the cables and attenuators used as part of the system to connect the EUT to the analyzer at all frequencies of interest.
- 3) All antenna port conducted emissions testing was performed on a test bench with the antenna port of the EUT connected to the spectrum analyzer through calibrated cables and attenuators.
- 4) Test Items “26dB Bandwidth”, “99% Bandwidth”, “6dB Bandwidth” & “Operation Frequency Range of 26dB BW” have been assessed single and MIMO transmission, and showed the worst test data in this report.

7.2. 26dB Bandwidth Measurement

7.2.1. Test Limit

N/A

7.2.2. Test Procedure used

KDB 789033 D02v01 – Section C.1

7.2.3. Test Setting

1. The analyzers' automatic bandwidth measurement capability was used to perform the 26dB bandwidth measurement. The "X" dB bandwidth parameter was set to $X = 26$. The automatic bandwidth measurement function also has the capability of simultaneously measuring the 99% occupied bandwidth. The bandwidth measurement was not influenced by any intermediated power nulls in the fundamental emission.
2. RBW = approximately 1% of the emission bandwidth.
3. VBW $\geq 3 \times$ RBW.
4. Detector = Peak.
5. Trace mode = max hold.

7.2.4. Test Setup

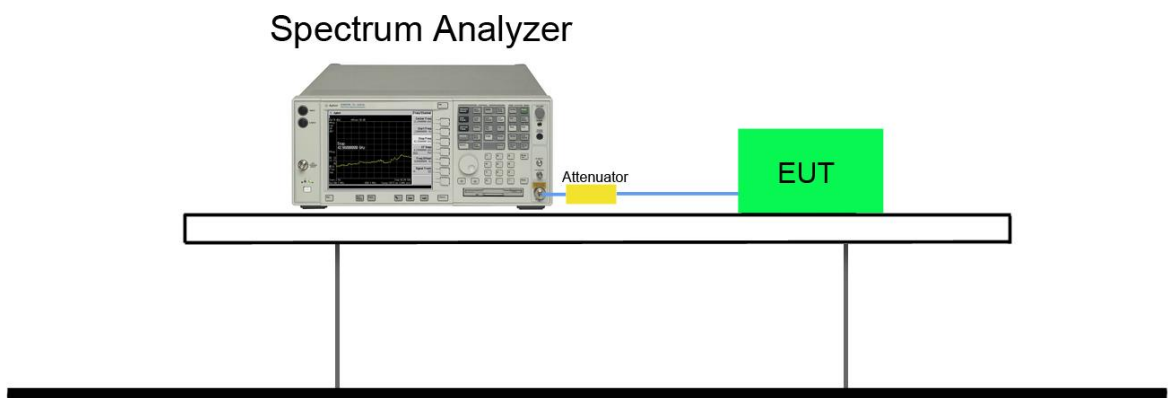

7.2.5. Test Result

Test Mode	Data Rate (Mbps)	Channel No.	Frequency (MHz)	26dB Bandwidth (MHz)	99% Bandwidth (MHz)
Ant 1					
802.11a	6	36	5180	22.11	16.67
802.11a	6	44	5220	21.11	16.72
802.11a	6	48	5240	21.44	16.65
802.11a	6	52	5260	21.90	16.67
802.11a	6	60	5300	21.74	16.65
802.11a	6	64	5320	21.25	16.63
802.11a	6	100	5500	21.77	16.66
802.11a	6	116	5580	20.80	16.65
802.11a	6	120	5600	21.89	16.67
802.11a	6	140	5700	21.42	16.67
802.11a	6	149	5745	22.19	16.66
802.11a	6	157	5785	21.39	16.67
802.11a	6	165	5825	22.19	16.67
802.11n-HT20	6.5	36	5180	22.03	17.78
802.11n-HT20	6.5	44	5220	22.66	17.80
802.11n-HT20	6.5	48	5240	22.80	17.82
802.11n-HT20	6.5	52	5260	24.08	17.83
802.11n-HT20	6.5	60	5300	22.29	17.80
802.11n-HT20	6.5	64	5320	22.55	17.81
802.11n-HT20	6.5	100	5500	22.67	17.80
802.11n-HT20	6.5	116	5580	22.31	17.81
802.11n-HT20	6.5	120	5600	22.86	17.80
802.11n-HT20	6.5	140	5700	23.11	17.79
802.11n-HT20	6.5	149	5745	22.41	17.85
802.11n-HT20	6.5	157	5785	23.11	17.80
802.11n-HT20	6.5	165	5825	22.53	17.80

Test Mode	Data Rate (Mbps)	Channel No.	Frequency (MHz)	26dB Bandwidth (MHz)	99% Bandwidth (MHz)
Ant 1					
802.11n-HT40	13.5	38	5190	44.73	36.47
802.11n-HT40	13.5	46	5230	43.40	36.33
802.11n-HT40	13.5	54	5270	47.61	36.41
802.11n-HT40	13.5	62	5310	45.47	36.33
802.11n-HT40	13.5	102	5510	43.37	36.37
802.11n-HT40	13.5	110	5550	43.25	36.33
802.11n-HT40	13.5	118	5590	45.58	36.44
802.11n-HT40	13.5	134	5670	43.43	36.41
802.11n-HT40	13.5	151	5755	43.99	36.37
802.11n-HT40	13.5	159	5795	45.22	36.39
802.11ac-VHT20	6.5	36	5180	21.95	17.79
802.11ac-VHT20	6.5	44	5220	22.03	17.79
802.11ac-VHT20	6.5	48	5240	22.43	17.83
802.11ac-VHT20	6.5	52	5260	24.31	17.87
802.11ac-VHT20	6.5	60	5300	22.58	17.80
802.11ac-VHT20	6.5	64	5320	23.34	17.77
802.11ac-VHT20	6.5	100	5500	22.52	17.83
802.11ac-VHT20	6.5	116	5580	22.34	17.76
802.11ac-VHT20	6.5	120	5600	22.86	17.80
802.11ac-VHT20	6.5	140	5700	22.65	17.84
802.11ac-VHT20	6.5	144	5720	22.88	17.81
802.11ac-VHT20	6.5	149	5745	22.63	17.82
802.11ac-VHT20	6.5	157	5785	23.15	17.80
802.11ac-VHT20	6.5	165	5825	23.55	17.85

Test Mode	Data Rate (Mbps)	Channel No.	Frequency (MHz)	26dB Bandwidth (MHz)	99% Bandwidth (MHz)
Ant 1					
802.11ac-VHT40	13.5	38	5190	44.11	36.38
802.11ac-VHT40	13.5	46	5230	42.66	36.35
802.11ac-VHT40	13.5	54	5270	45.91	36.39
802.11ac-VHT40	13.5	62	5310	42.81	36.39
802.11ac-VHT40	13.5	102	5510	42.91	36.38
802.11ac-VHT40	13.5	110	5550	42.42	36.31
802.11ac-VHT40	13.5	118	5590	44.55	36.45
802.11ac-VHT40	13.5	134	5670	44.99	36.40
802.11ac-VHT40	13.5	142	5710	43.61	36.31
802.11ac-VHT40	13.5	151	5755	43.10	36.38
802.11ac-VHT40	13.5	159	5795	43.60	36.40
802.11ac-VHT80	29.3	42	5210	85.94	75.81
802.11ac-VHT80	29.3	58	5290	84.78	75.76
802.11ac-VHT80	29.3	106	5530	87.43	75.93
802.11ac-VHT80	29.3	122	5610	90.15	75.99
802.11ac-VHT80	29.3	138	5690	84.85	75.78
802.11ac-VHT80	29.3	155	5775	86.65	75.79

Test Mode	Data Rate (Mbps)	Channel No.	Frequency (MHz)	26dB Bandwidth (MHz)	99% Bandwidth (MHz)
Ant 2					
802.11a	6	36	5180	21.27	16.63
802.11a	6	44	5220	21.71	16.63
802.11a	6	48	5240	21.00	16.64
802.11a	6	52	5260	22.17	16.70
802.11a	6	60	5300	21.35	16.65
802.11a	6	64	5320	21.53	16.65
802.11a	6	100	5500	21.41	16.64
802.11a	6	116	5580	21.51	16.64
802.11a	6	120	5600	21.31	16.66
802.11a	6	140	5700	21.09	16.63
802.11a	6	149	5745	21.09	16.66
802.11a	6	157	5785	21.01	16.66
802.11a	6	165	5825	21.44	16.68
802.11n-HT20	6.5	36	5180	23.69	17.89
802.11n-HT20	6.5	44	5220	22.32	17.81
802.11n-HT20	6.5	48	5240	22.48	17.77
802.11n-HT20	6.5	52	5260	22.56	17.79
802.11n-HT20	6.5	60	5300	22.53	17.83
802.11n-HT20	6.5	64	5320	22.18	17.77
802.11n-HT20	6.5	100	5500	21.91	17.78
802.11n-HT20	6.5	116	5580	23.07	17.81
802.11n-HT20	6.5	120	5600	22.85	17.84
802.11n-HT20	6.5	140	5700	21.56	17.78
802.11n-HT20	6.5	149	5745	22.06	17.80
802.11n-HT20	6.5	157	5785	22.62	17.83
802.11n-HT20	6.5	165	5825	22.37	17.81

Test Mode	Data Rate (Mbps)	Channel No.	Frequency (MHz)	26dB Bandwidth (MHz)	99% Bandwidth (MHz)
Ant 2					
802.11n-HT40	13.5	38	5190	44.95	36.43
802.11n-HT40	13.5	46	5230	44.26	36.41
802.11n-HT40	13.5	54	5270	45.34	36.42
802.11n-HT40	13.5	62	5310	45.35	36.40
802.11n-HT40	13.5	102	5510	42.36	36.31
802.11n-HT40	13.5	110	5550	42.81	36.35
802.11n-HT40	13.5	118	5590	43.97	36.45
802.11n-HT40	13.5	134	5670	44.94	36.37
802.11n-HT40	13.5	151	5755	44.51	36.39
802.11n-HT40	13.5	159	5795	45.34	36.41
802.11ac-VHT20	6.5	36	5180	22.48	17.78
802.11ac-VHT20	6.5	44	5220	22.37	17.80
802.11ac-VHT20	6.5	48	5240	22.57	17.80
802.11ac-VHT20	6.5	52	5260	22.70	17.81
802.11ac-VHT20	6.5	60	5300	22.83	17.78
802.11ac-VHT20	6.5	64	5320	22.04	17.76
802.11ac-VHT20	6.5	100	5500	22.73	17.84
802.11ac-VHT20	6.5	116	5580	22.59	17.83
802.11ac-VHT20	6.5	120	5600	22.35	17.81
802.11ac-VHT20	6.5	140	5700	21.85	17.77
802.11ac-VHT20	6.5	144	5720	22.67	17.76
802.11ac-VHT20	6.5	149	5745	22.08	17.82
802.11ac-VHT20	6.5	157	5785	22.31	17.84
802.11ac-VHT20	6.5	165	5825	22.08	17.82

Test Mode	Data Rate (Mbps)	Channel No.	Frequency (MHz)	26dB Bandwidth (MHz)	99% Bandwidth (MHz)
Ant 2					
802.11ac-VHT40	13.5	38	5190	44.07	36.39
802.11ac-VHT40	13.5	46	5230	43.18	36.36
802.11ac-VHT40	13.5	54	5270	43.91	36.37
802.11ac-VHT40	13.5	62	5310	43.41	36.39
802.11ac-VHT40	13.5	102	5510	42.66	36.31
802.11ac-VHT40	13.5	110	5550	43.15	36.35
802.11ac-VHT40	13.5	118	5590	44.15	36.33
802.11ac-VHT40	13.5	134	5670	43.17	36.31
802.11ac-VHT40	13.5	142	5710	42.53	36.40
802.11ac-VHT40	13.5	151	5755	43.50	36.38
802.11ac-VHT40	13.5	159	5795	44.25	36.44
802.11ac-VHT80	29.3	42	5210	86.04	75.79
802.11ac-VHT80	29.3	58	5290	86.69	75.87
802.11ac-VHT80	29.3	106	5530	84.99	75.54
802.11ac-VHT80	29.3	122	5610	85.70	75.77
802.11ac-VHT80	29.3	138	5690	86.79	75.94
802.11ac-VHT80	29.3	155	5775	85.04	75.71

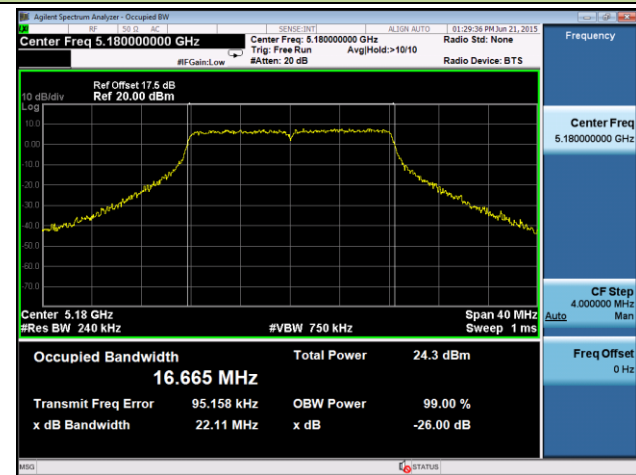
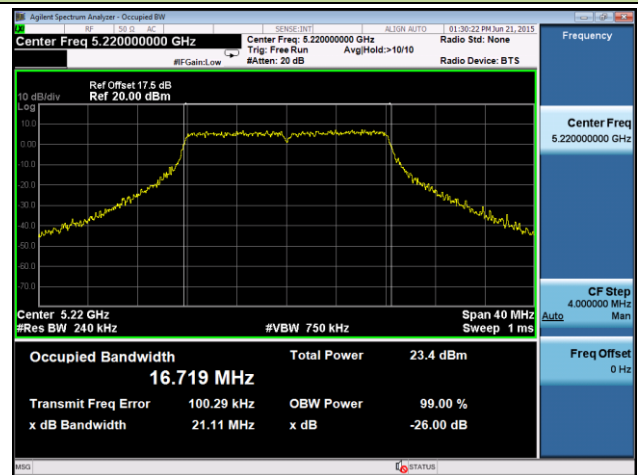
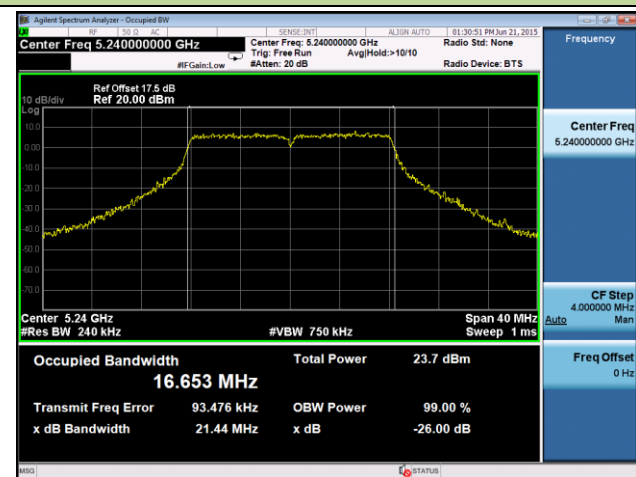
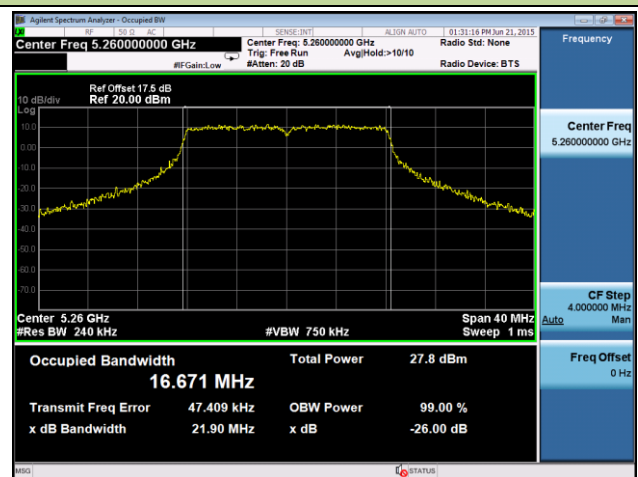
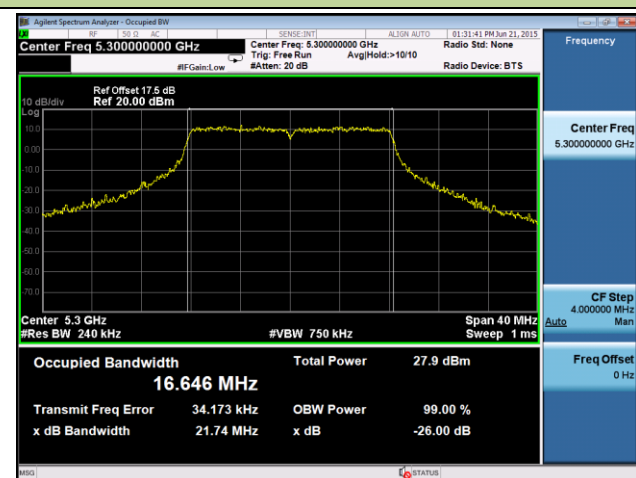
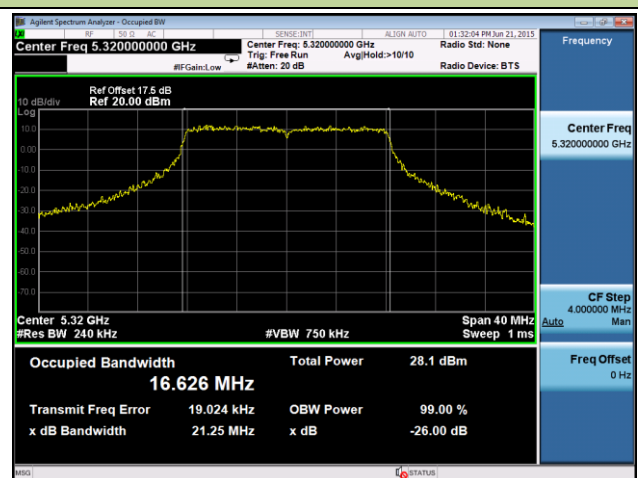
802.11a 26dB Bandwidth & 99% Bandwidth - Ant 1
Channel 36 (5180MHz)

Channel 44 (5220MHz)

Channel 48 (5240MHz)

Channel 52 (5260MHz)

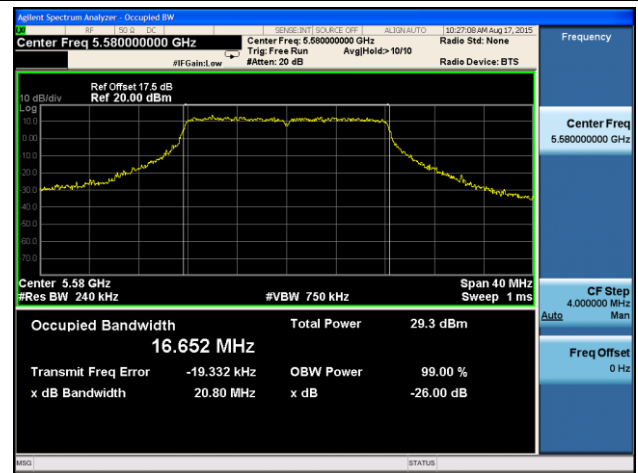
Channel 60 (5300MHz)

Channel 64 (5320MHz)

Channel 100 (5500MHz)



Channel 116 (5580MHz)



Channel 120 (5600MHz)

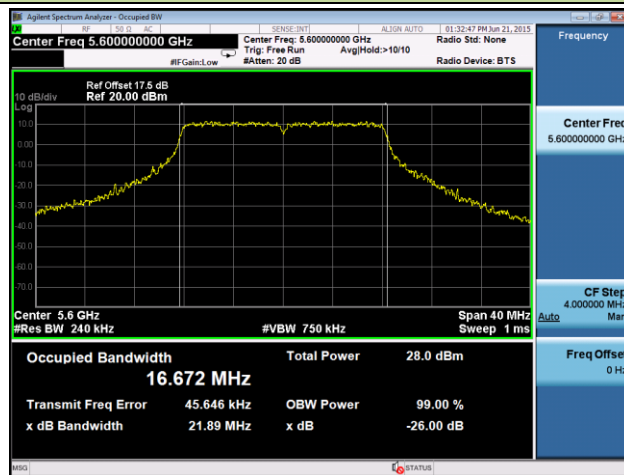

Channel 140 (5700MHz)

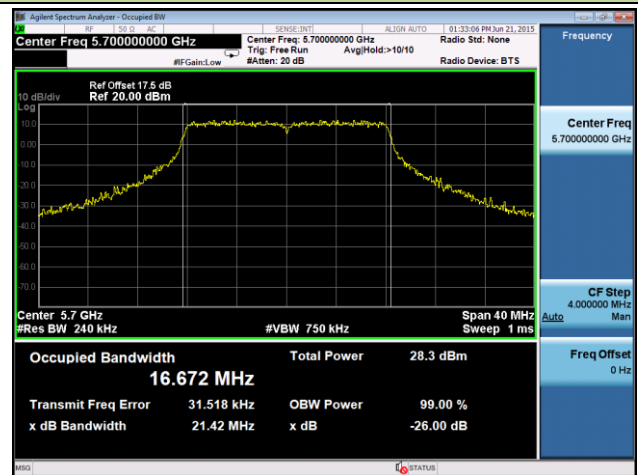

Channel 149 (5745MHz)

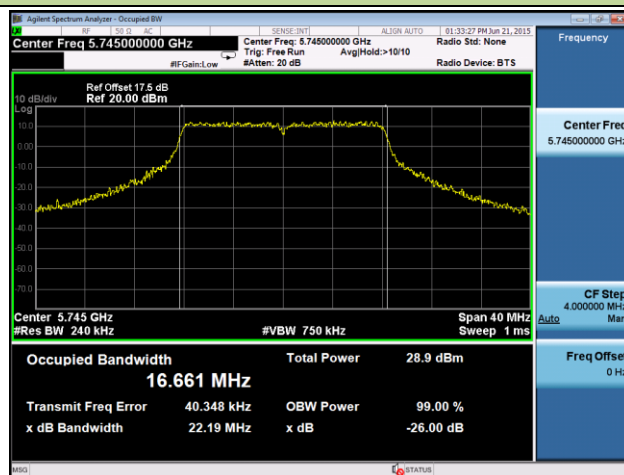

Channel 157 (5785MHz)

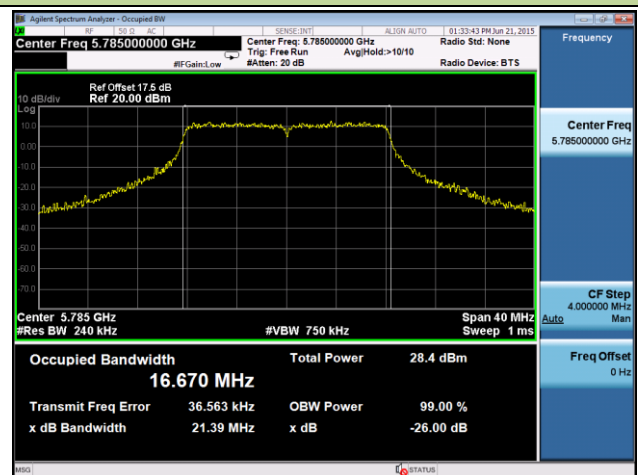

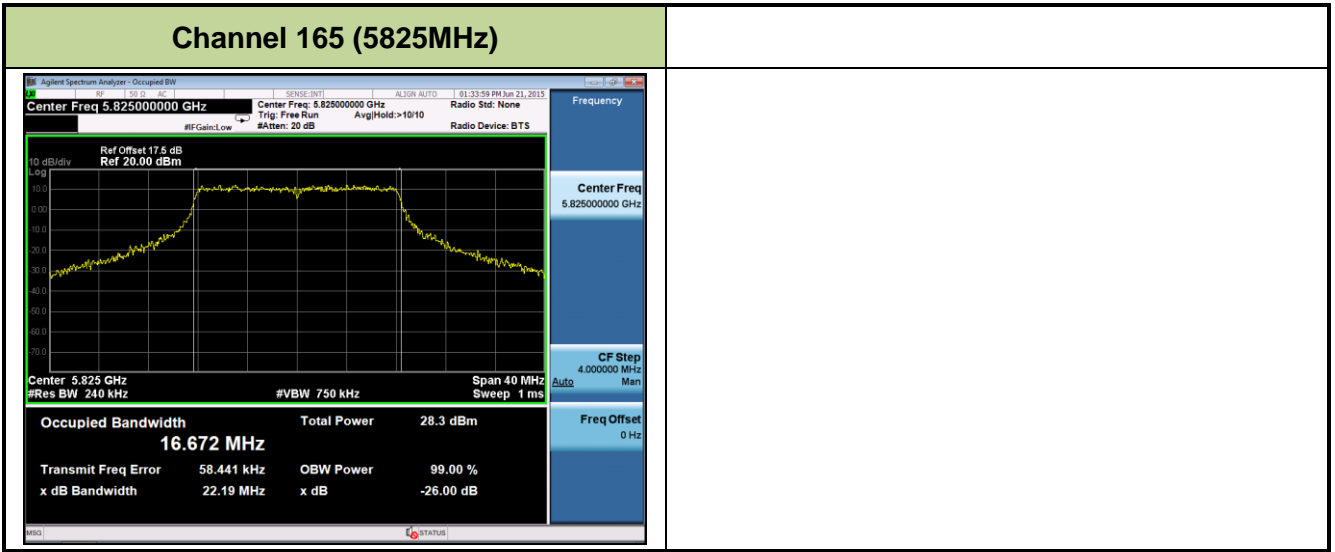

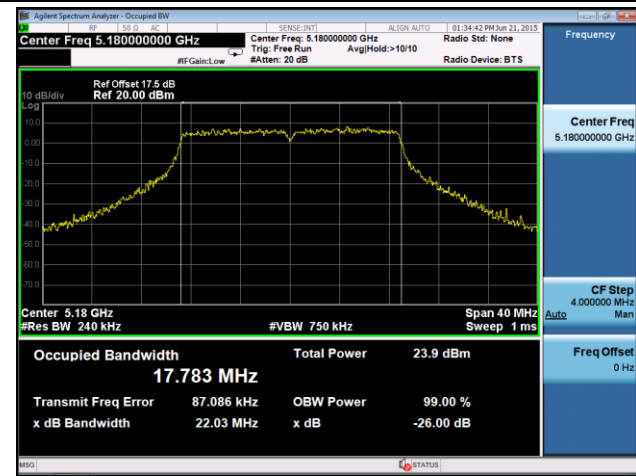
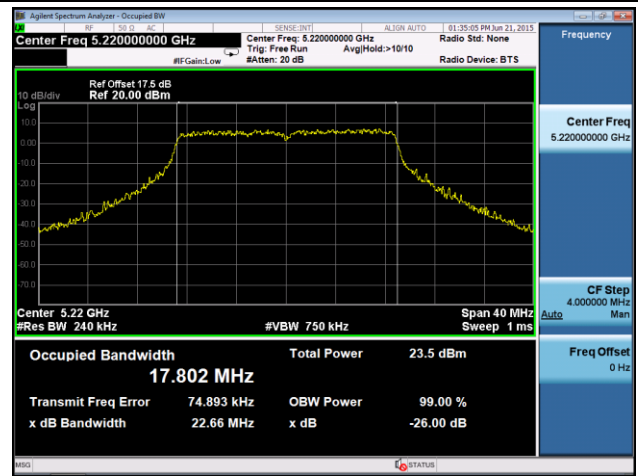
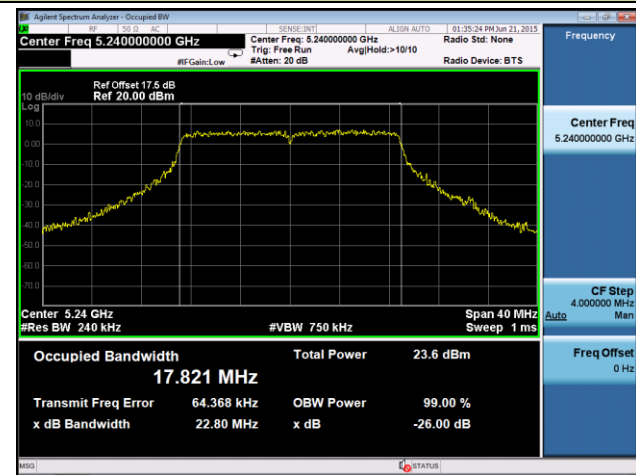
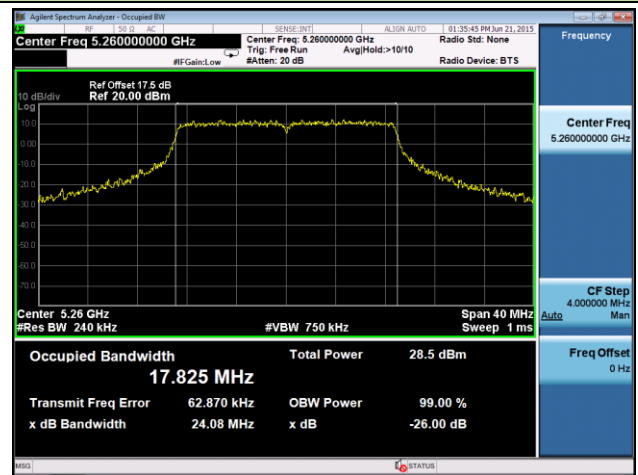
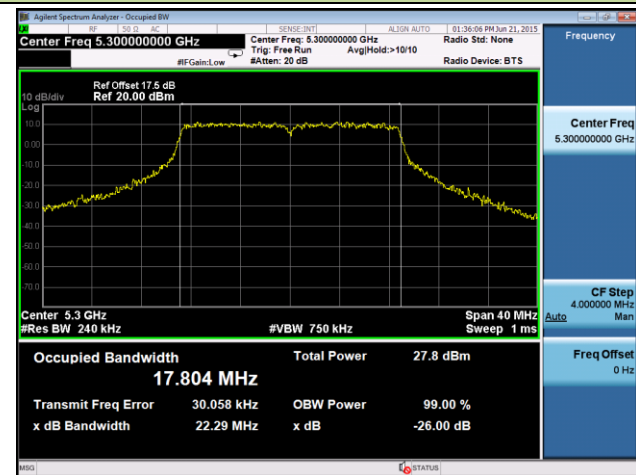
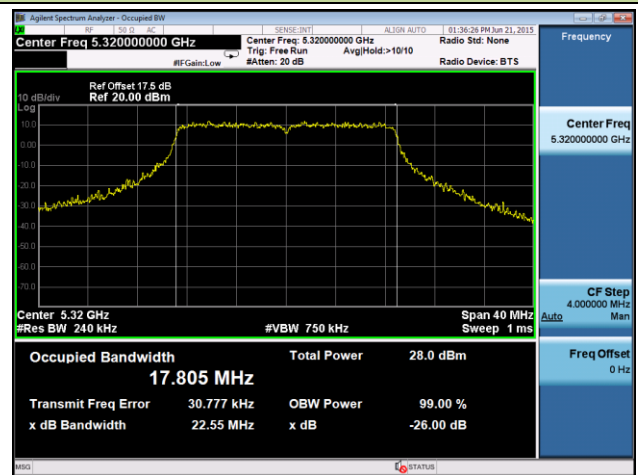
802.11n-HT20 26dB Bandwidth & 99% Bandwidth - Ant 1
Channel 36 (5180MHz)

Channel 44 (5220MHz)

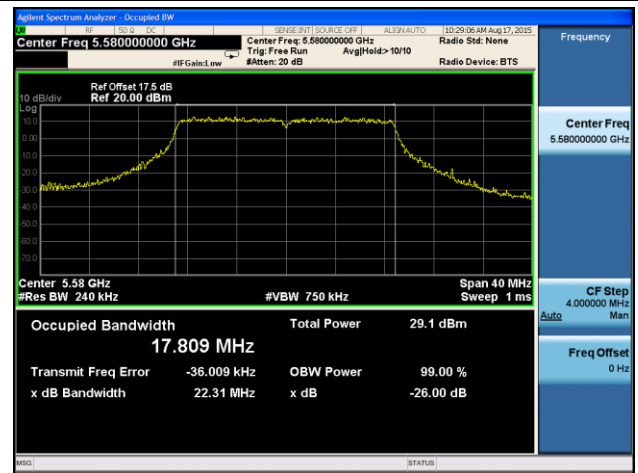
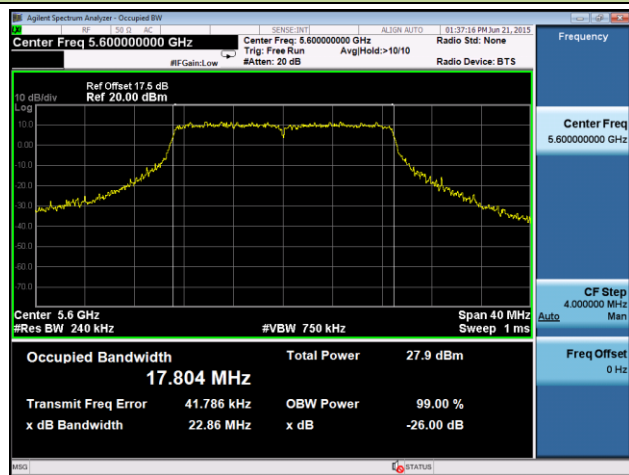
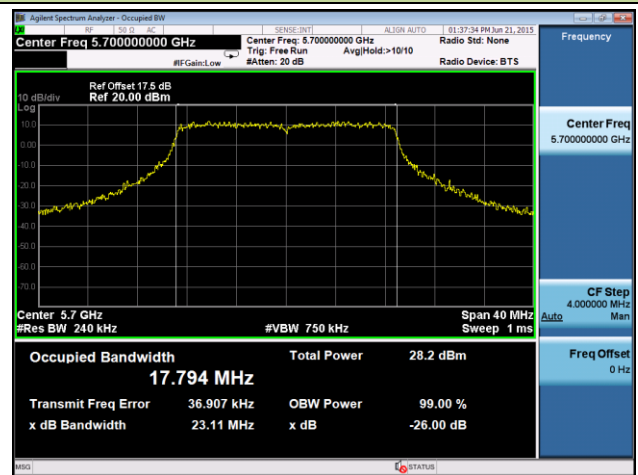
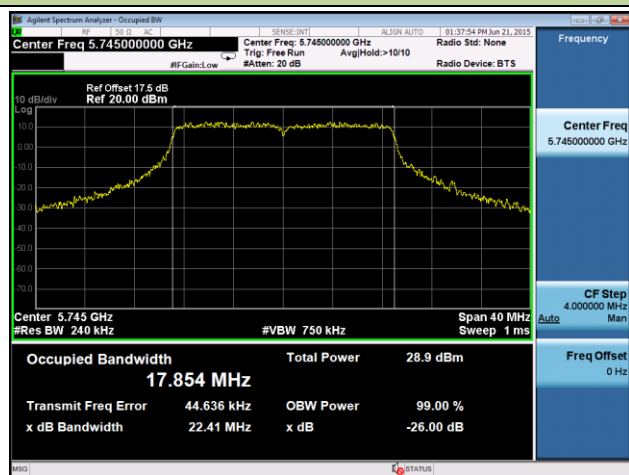
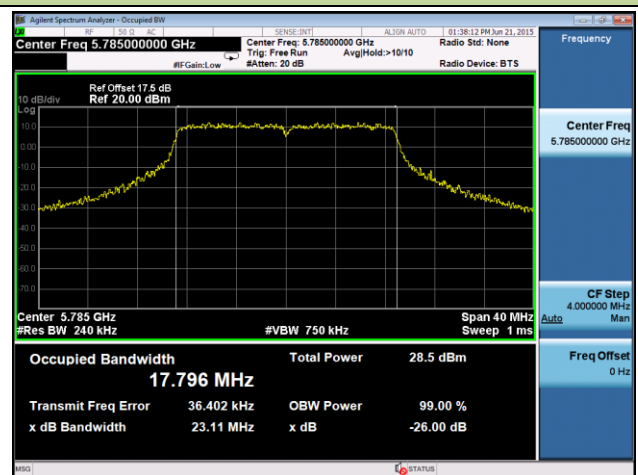
Channel 48 (5240MHz)

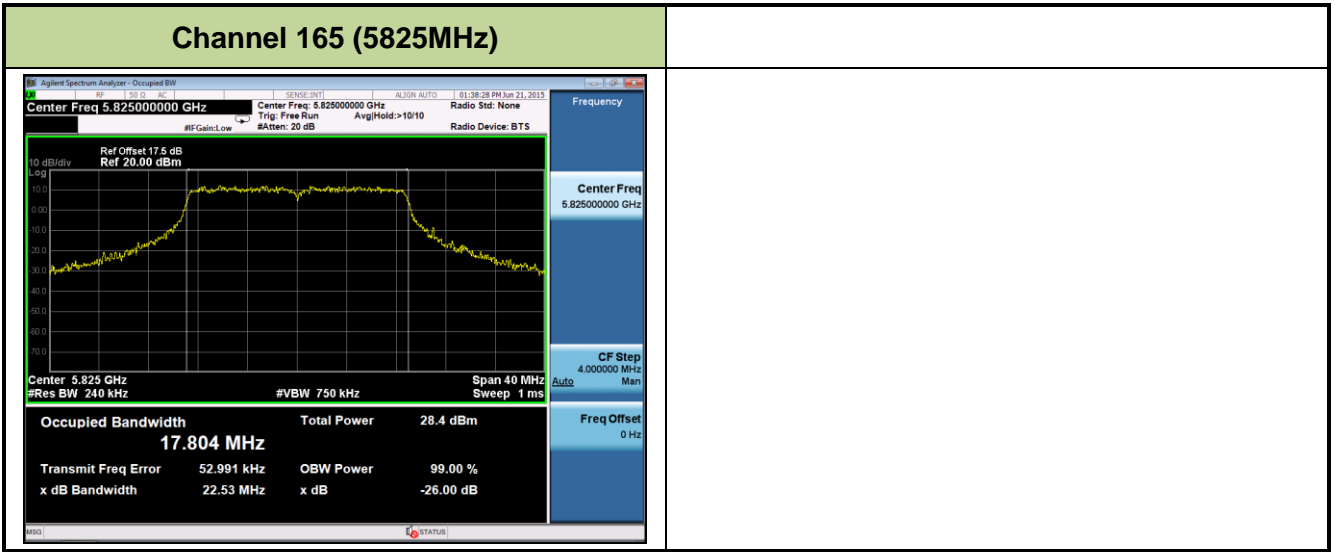
Channel 52 (5260MHz)

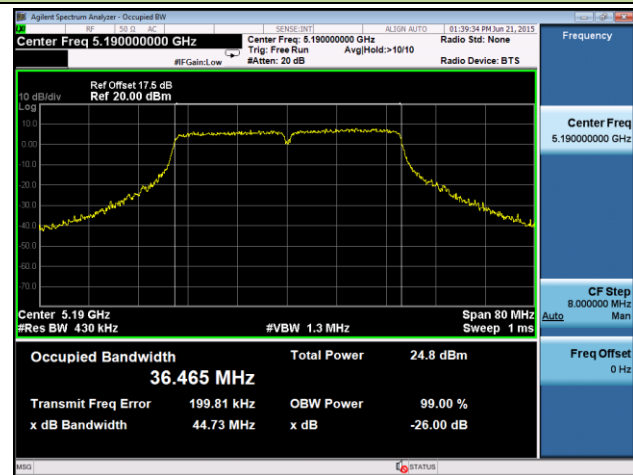
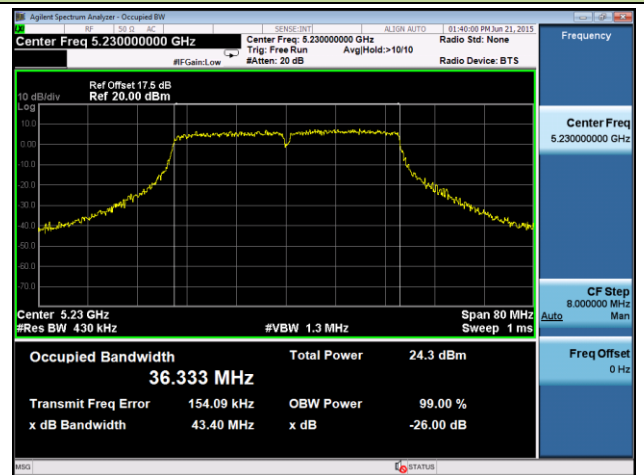
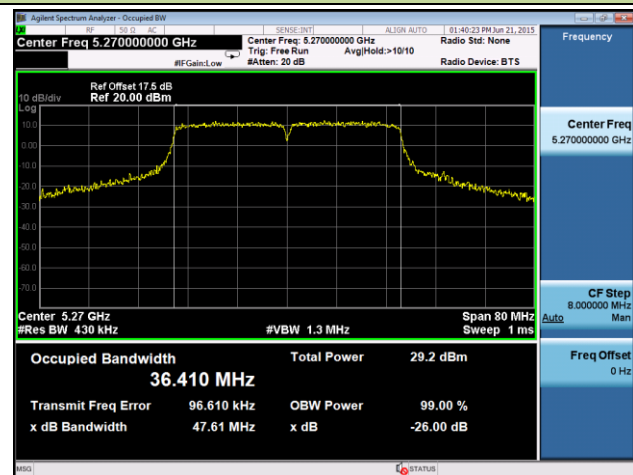
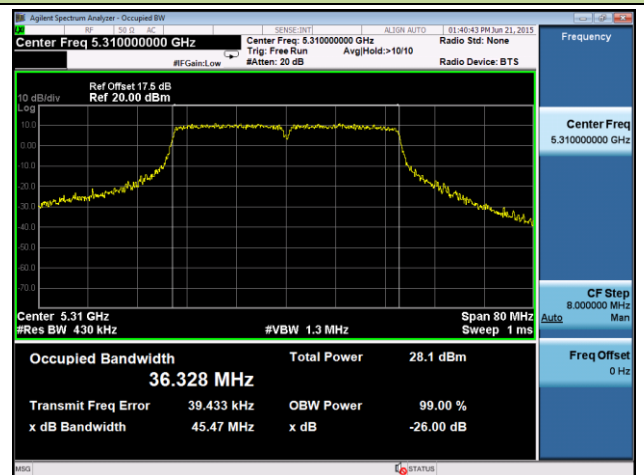
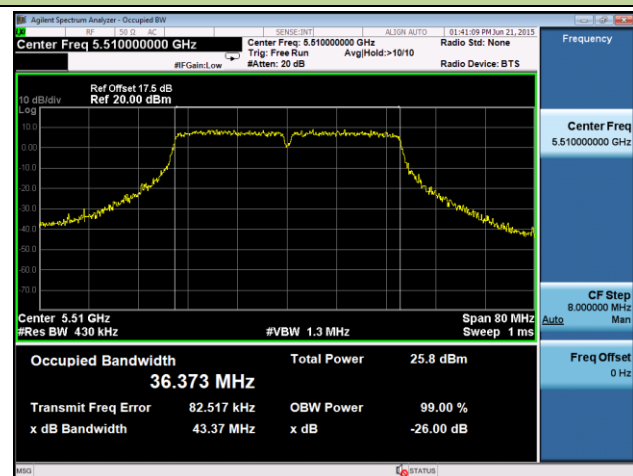
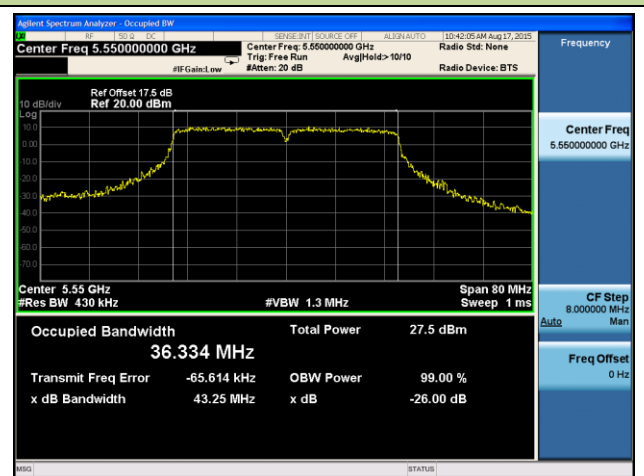
Channel 60 (5300MHz)

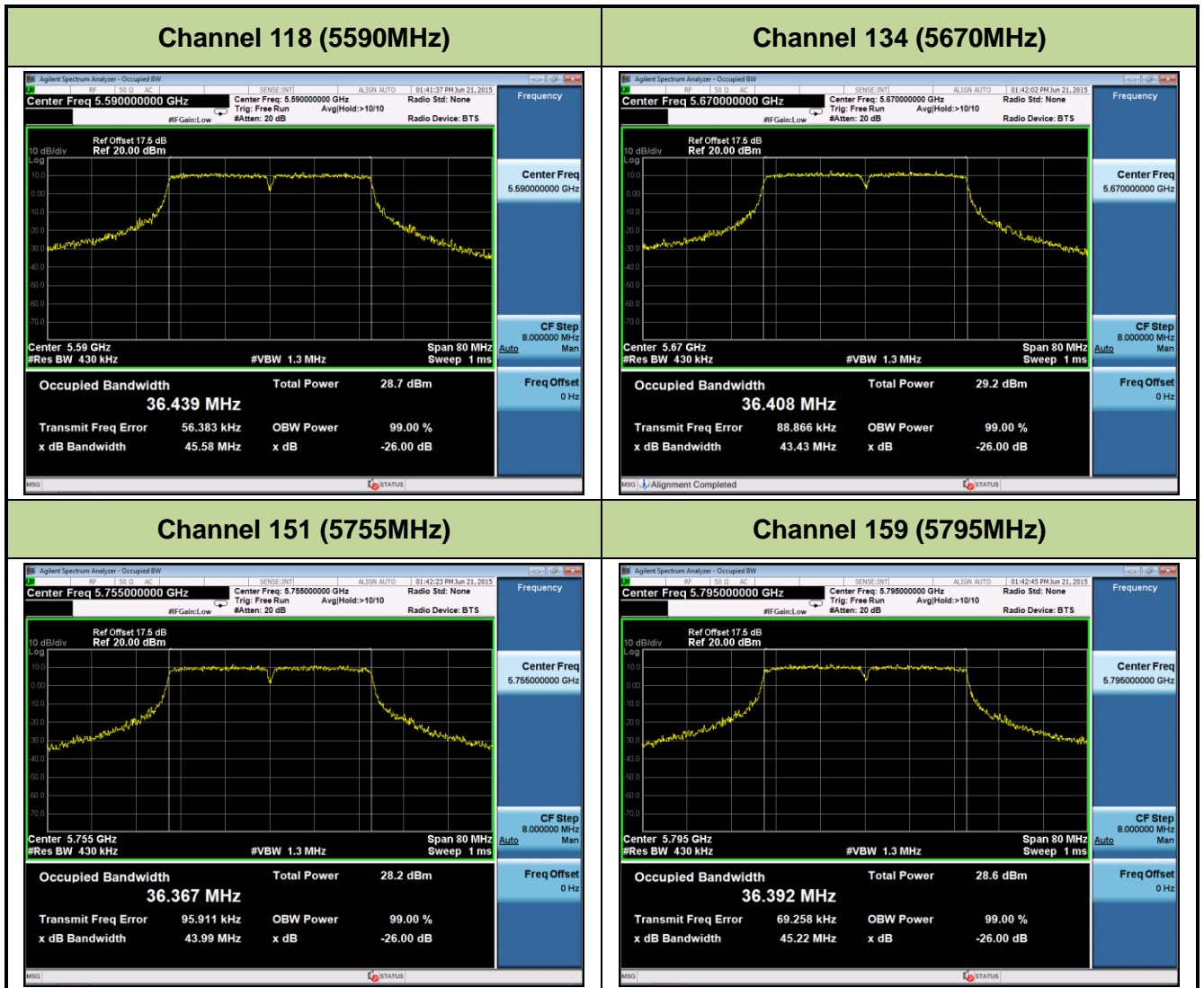
Channel 64 (5320MHz)

Channel 100 (5500MHz)

Channel 116 (5580MHz)

Channel 120 (5600MHz)

Channel 140 (5700MHz)

Channel 149 (5745MHz)

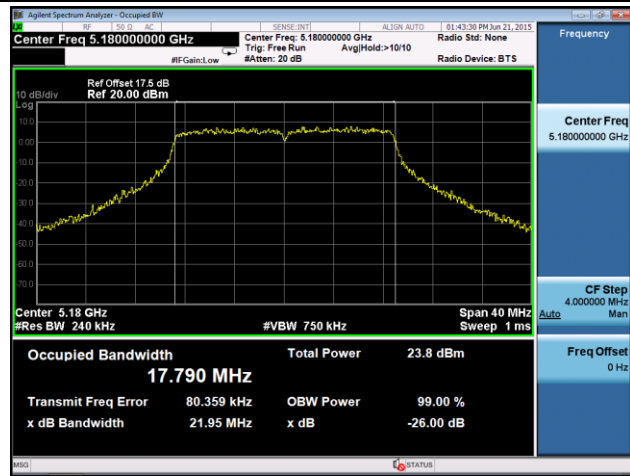
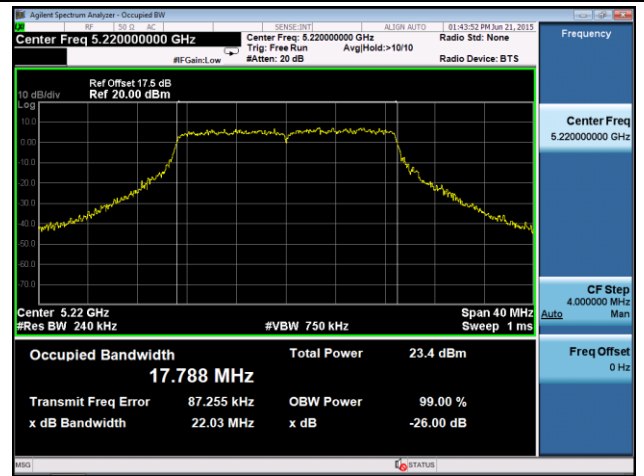
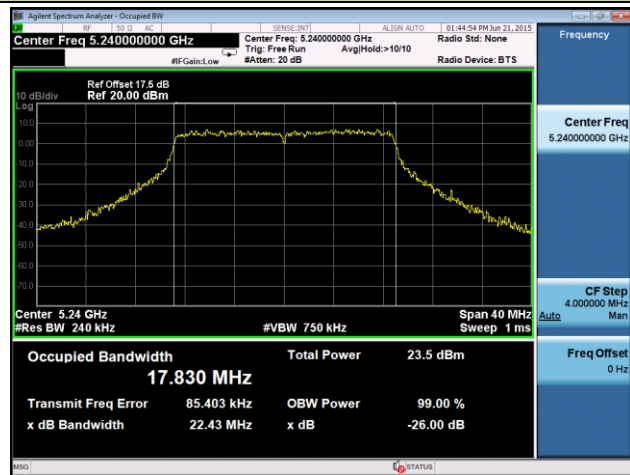
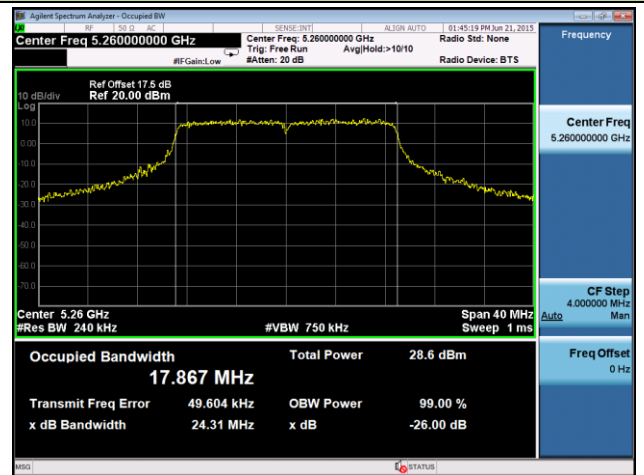
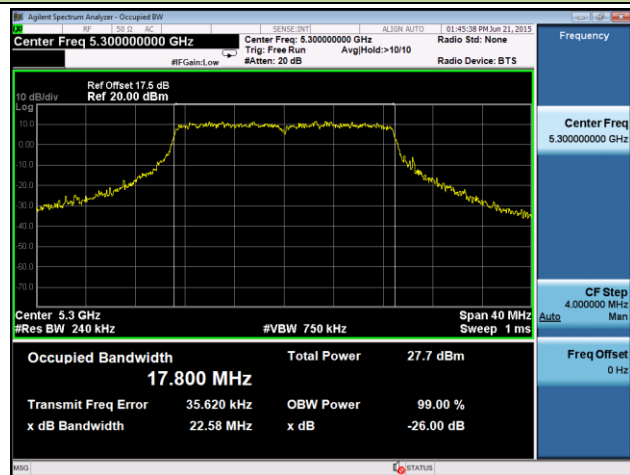
Channel 157 (5785MHz)



802.11n-HT40 26dB Bandwidth & 99% Bandwidth - Ant 1
Channel 38 (5190MHz)

Channel 46 (5230MHz)

Channel 54 (5270MHz)

Channel 62 (5310MHz)

Channel 102 (5510MHz)

Channel 110 (5550MHz)



802.11ac-VHT20 26dB Bandwidth & 99% Bandwidth - Ant 1
Channel 36 (5180MHz)

Channel 44 (5220MHz)

Channel 48 (5240MHz)

Channel 52 (5260MHz)

Channel 60 (5300MHz)

Channel 64 (5320MHz)
