



MEASUREMENT REPORT

FCC PART 15.247 & IC RSS-247 WLAN 802.11b/g/n

FCC ID: 2AD8UFZCWI2A1
IC: 109D-FZCWI2A01
APPLICANT: Nokia Solutions and Networks
Application Type: Certification
Product: Wireless Access Point
Model No.: WI2A-AC200i
Trademark: Nokia
FCC Classification: Digital Transmission System (DTS)
FCC Rule Part(s): Part 15.247
IC Rule(s): RSS-247 Issue 1
Test Procedure(s): ANSI C63.10-2013, KDB 558074 D01v03r03,
KDB 662911 D01v02r01
Test Date: June 16 ~ August 14, 2015

Reviewed By : Robin Wu
(Robin Wu)

Approved By : Marlin Chen
(Marlin Chen)



The test results relate only to the samples tested.

This equipment has been shown to be capable of compliance with the applicable technical standards as indicated in the measurement report and was tested in accordance with the measurement procedures specified in KDB 558074 D01v03r03. Test results reported herein relate only to the item(s) tested.

The test report shall not be reproduced except in full without the written approval of MRT Technology (Suzhou) Co., Ltd.

Revision History

Report No.	Version	Description	Issue Date
1506RSU00611	Rev. 01	Initial report	10-01-2015
1506RSU00611	Rev. 02	Revised the PSD test data	10-23-2015

CONTENTS

Description	Page
§2.1033 General Information.....	5
1. INTRODUCTION.....	6
1.1. Scope.....	6
1.2. MRT Test Location.....	6
2. PRODUCT INFORMATION.....	7
2.1. Equipment Description.....	7
2.2. Working Frequencies.....	8
2.3. Description of Available Antennas.....	9
2.4. Description of Antenna RF Port.....	10
2.5. Test Mode.....	10
2.6. Device Capabilities.....	11
2.7. Test Configuration.....	12
2.8. EMI Suppression Device(s)/Modifications.....	12
2.9. Labeling Requirements.....	12
3. DESCRIPTION of TEST.....	13
3.1. Evaluation Procedure.....	13
3.2. AC Line Conducted Emissions.....	13
3.3. Radiated Emissions.....	14
4. ANTENNA REQUIREMENTS.....	15
5. TEST EQUIPMENT CALIBRATION DATE.....	16
6. MEASUREMENT UNCERTAINTY.....	17
7. TEST RESULT.....	18
7.1. Summary.....	18
7.2. 6dB Bandwidth Measurement.....	20
7.2.1. Test Limit.....	20
7.2.2. Test Procedure used.....	20
7.2.3. Test Setting.....	20
7.2.4. Test Setup.....	20
7.2.5. Test Result.....	21
7.3. Output Power Measurement.....	30
7.3.1. Test Limit.....	30
7.3.2. Test Procedure Used.....	30
7.3.3. Test Setting.....	30

7.3.4.	Test Setup	30
7.3.5.	Test Result of Output Power	31
7.4.	Power Spectral Density Measurement	35
7.4.1.	Test Limit	35
7.4.2.	Test Procedure Used	35
7.4.3.	Test Setting.....	35
7.4.4.	Test Setup	36
7.4.5.	Test Result.....	37
7.5.	Conducted Band Edge and Out-of-Band Emissions	55
7.5.1.	Test Limit	55
7.5.2.	Test Procedure Used	55
7.5.3.	Test Setting.....	55
7.5.4.	Test Setup	56
7.5.5.	Test Result.....	57
7.6.	Radiated Spurious Emission Measurement	74
7.6.1.	Test Limit	74
7.6.2.	Test Procedure Used	74
7.6.3.	Test Setting.....	74
7.6.4.	Test Setup	76
7.6.5.	Test Result.....	78
7.7.	Radiated Restricted Band Edge Measurement	120
7.7.1.	Test Result.....	120
7.8.	AC Conducted Emissions Measurement	216
7.8.1.	Test Limit	216
7.8.2.	Test Setup	216
7.8.3.	Test Result.....	217
8.	CONCLUSION	219

§2.1033 General Information

Applicant:	Nokia Solutions and Networks
Applicant Address:	Karaportti 3, P.O. Box 226, FI-00045 Nokia Group, Finland
Manufacturer:	Nokia Solutions and Networks
Manufacturer Address:	Karaportti 3, P.O. Box 226, FI-00045 Nokia Group, Finland
Test Site:	MRT Technology (Suzhou) Co., Ltd
Test Site Address:	D8 Building, Youxin Industrial Park, No.2 Tian'edang Rd., Wuzhong Economic Development Zone, Suzhou, China
MRT FCC Registration No.:	809388
MRT IC Registration No.:	11384A
FCC Rule Part(s):	Part 15.247
IC Rule(s):	RSS-247 Issue 1
Model No.:	WI2A-AC200i
FCC ID:	2AD8UFZCWI2A1
IC:	109D-FZCWI2A01
Test Device Serial No.:	N/A <input type="checkbox"/> Production <input checked="" type="checkbox"/> Pre-Production <input type="checkbox"/> Engineering

Test Facility / Accreditations

Measurements were performed at MRT Laboratory located in Tian'edang Rd., Suzhou, China.

- MRT facility is a FCC registered (MRT Reg. No. 809388) test facility with the site description report on file and has met all the requirements specified in Section 2.948 of the FCC Rules.
- MRT facility is an IC registered (MRT Reg. No. 11384A-1) test laboratory with the site description on file at Industry Canada.
- MRT facility is a VCCI registered (R-4179, G-814, C-4664, T-2206) test laboratory with the site description on file at VCCI Council.
- MRT Lab is accredited to ISO 17025 by the American Association for Laboratory Accreditation (A2LA) under the American Association for Laboratory Accreditation Program (A2LA Cert. No. 3628.01) in EMC, Telecommunications and Radio testing for FCC, Industry Canada, EU and TELEC Rules.



1. INTRODUCTION

1.1. Scope

Measurement and determination of electromagnetic emissions (EMC) of radio frequency devices including intentional and/or unintentional radiators for compliance with the technical rules and regulations of the Federal Communications Commission and the Industry Canada Certification and Engineering Bureau.

1.2. MRT Test Location

The map below shows the location of the MRT LABORATORY, its proximity to the Taihu Lake. These measurement tests were conducted at the MRT Technology (Suzhou) Co., Ltd. Facility located at D8 Building, Youxin Industrial Park, No.2 Tian'edang Rd., Wuzhong Economic Development Zone, Suzhou, China. The detailed description of the measurement facility was found to be in compliance with the requirements of § 2.948 according to ANSI C63.4-2009 on September 30, 2013.



2. PRODUCT INFORMATION

2.1. Equipment Description

Product Name	Wireless Access Point
Model No.	WI2A-AC200i
Brand Name	Nokia
Hardware Version	v2.0
Wi-Fi Specification	802.11a/b/g/n/ac
Frequency Range	<p><u>2.4GHz:</u> For 802.11b/g/n-HT20: 2412 ~ 2462 MHz For 802.11n-HT40: 2422 ~ 2452 MHz</p> <p><u>5GHz:</u> For 802.11a/n-HT20/ac-VHT20:: 5180~5240MHz, 5745~5825MHz For 802.11n-HT40/ac-VHT40: 5190~5230MHz, 5755~5795MHz For 802.11ac-VHT80: 5210MHz, 5775MHz</p>
2.4GHz Maximum Output Power	802.11b: 26.36dBm 802.11g: 25.49dBm 802.11n-HT20: 25.39dBm 802.11n-HT40: 25.46dBm
Type of Modulation	802.11b: DSSS 802.11g/n: OFDM
Components	
Adapter	M/N: DSA-12CA-12 120100 Input: 100-240V ~ 50/60Hz, 0.3A OUTPUT: 12Vdc, 1A
POE	M/N: PoE35-54A Input: 100-240V ~ 50/60Hz, 1A OUTPUT: 54Vdc, 0.65A

Note 1: For all of the test mode, two power supplies have been assessed in the spurious emission test, and showed the worst test data for AC Adpter (DSA-12CA-12 120100) in the test report.

Note 2: The change of the measured voltage at the radio part of the EUT is below $\pm 1\%$, when input voltage from external power supply (AC Adapter & POE Adapter) to the equipment under test, thus

the RF test is tested with AC Adapter only.

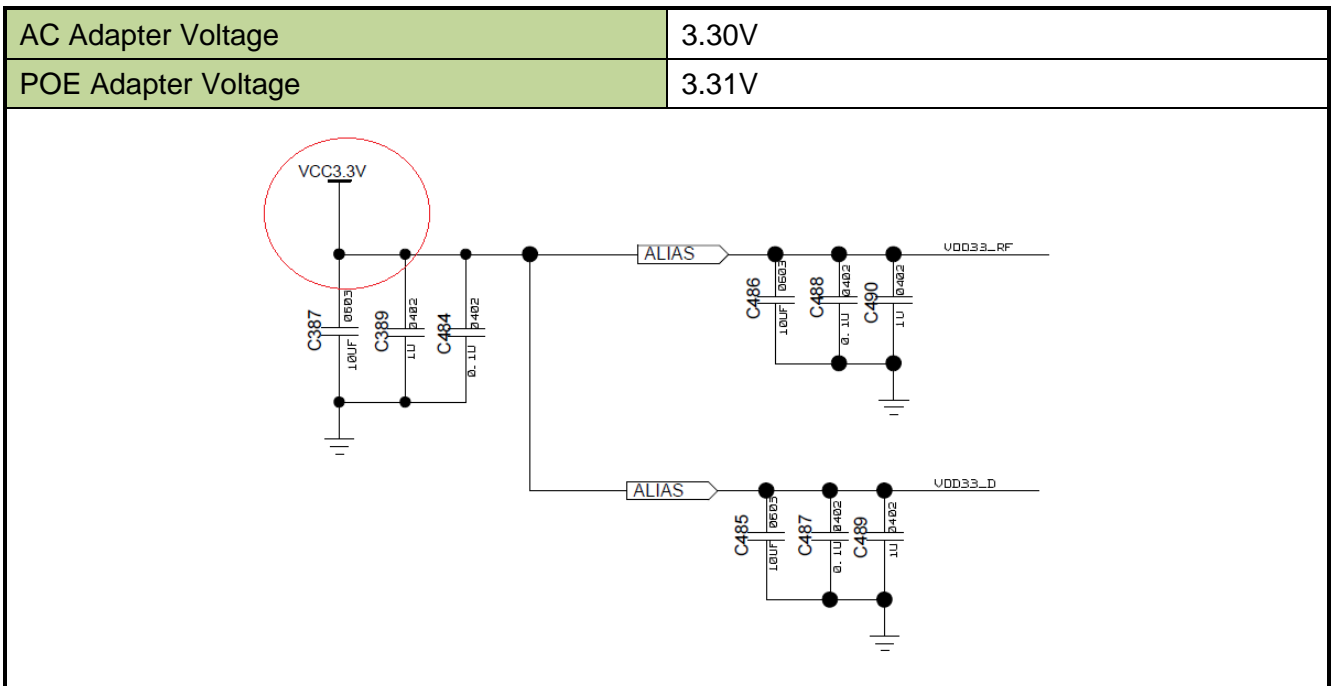

2.2. Working Frequencies for this report

Channel List for 802.11b/g/n-HT20

Channel	Frequency	Channel	Frequency	Channel	Frequency
01	2412 MHz	02	2417 MHz	03	2422 MHz
04	2427 MHz	05	2432 MHz	06	2437 MHz
07	2442 MHz	08	2447 MHz	09	2452 MHz
10	2457 MHz	11	2462 MHz	--	--

Channel List for 802.11n-HT40

Channel	Frequency	Channel	Frequency	Channel	Frequency
03	2422 MHz	04	2427 MHz	05	2432 MHz
06	2437 MHz	07	2442 MHz	08	2447 MHz
09	2452 MHz	--	--	--	--

2.3. Description of Available Antennas

Antenna Type	Frequency Band (MHz)	Tx Paths	Per Chain Max Antenna Gain (dBi)		Beam Forming Directional Gain (dBi)	CDD Directional Gain (dBi)
			Ant 1	Ant 2		
PCB Antenna	2412 ~2462	2	3.23	2.38	5.83	5.83
	5150 ~ 5250	2	5.40	4.53	7.99	7.99
	5725 ~ 5850	2	6.00	5.86	8.94	8.94

- The EUT supports Cyclic Delay Diversity (CDD) technology for 802.11a/b/g mode, and CDD signals are correlated.
- The EUT supports Beam Forming technology for 802.11n/ac mode, and exclude 802.11b/g mode.
Correlated signals include, but are not limited to, signals transmitted in any of the following modes:
 - Unequal Antenna gains, with equal transmit powers. For Antenna gains given by G_1, G_2, \dots, G_N dBi transmit signals are correlated, then
 - Directional gain = $10 \cdot \log\left[\frac{(10^{G_1/20} + 10^{G_2/20} + \dots + 10^{G_N/20})^2}{N_{ANT}}\right]$ dBi [Note the “20”s in the denominator of each exponent and the square of the sum of terms; the object is to combine the signal levels coherently.]
For example: 2.4GHz Directional Gain = $10 \cdot \log\left[\frac{(10^{3.23/20} + 10^{2.38/20})^2}{2}\right] = 5.83$ dBi

2.4. Description of Antenna RF Port

Antenna RF Port				
--	2.4GHz RF Port		5GHz RF Port	
Software Control Port	Ant 1	Ant 2	Ant 1	Ant 2

2.5. Test Mode

Test Mode	Mode 1: Transmit by 802.11b
	Mode 2: Transmit by 802.11g
	Mode 3: Transmit by 802.11n-HT20
	Mode 4: Transmit by 802.11n-HT40

2.6. Device Capabilities

This device contains the following capabilities:

2.4GHz WLAN (DTS).

Note: 2.4GHz WLAN (DTS) operation is possible in 20MHz, and 40MHz channel bandwidths. The maximum achievable duty cycles for all modes were determined based on measurements performed on a spectrum analyzer in zero-span mode with RBW = 8MHz, VBW = 50MHz. The RBW and VBW were both greater than 50/T, where T is the minimum transmission duration, and the number of sweep points across T was greater than 100. The duty cycles are as follows:

Test Mode	Duty Cycle
802.11b	99.51%
802.11g	96.45%
802.11n-HT20	96.21%
802.11n-HT40	94.62%

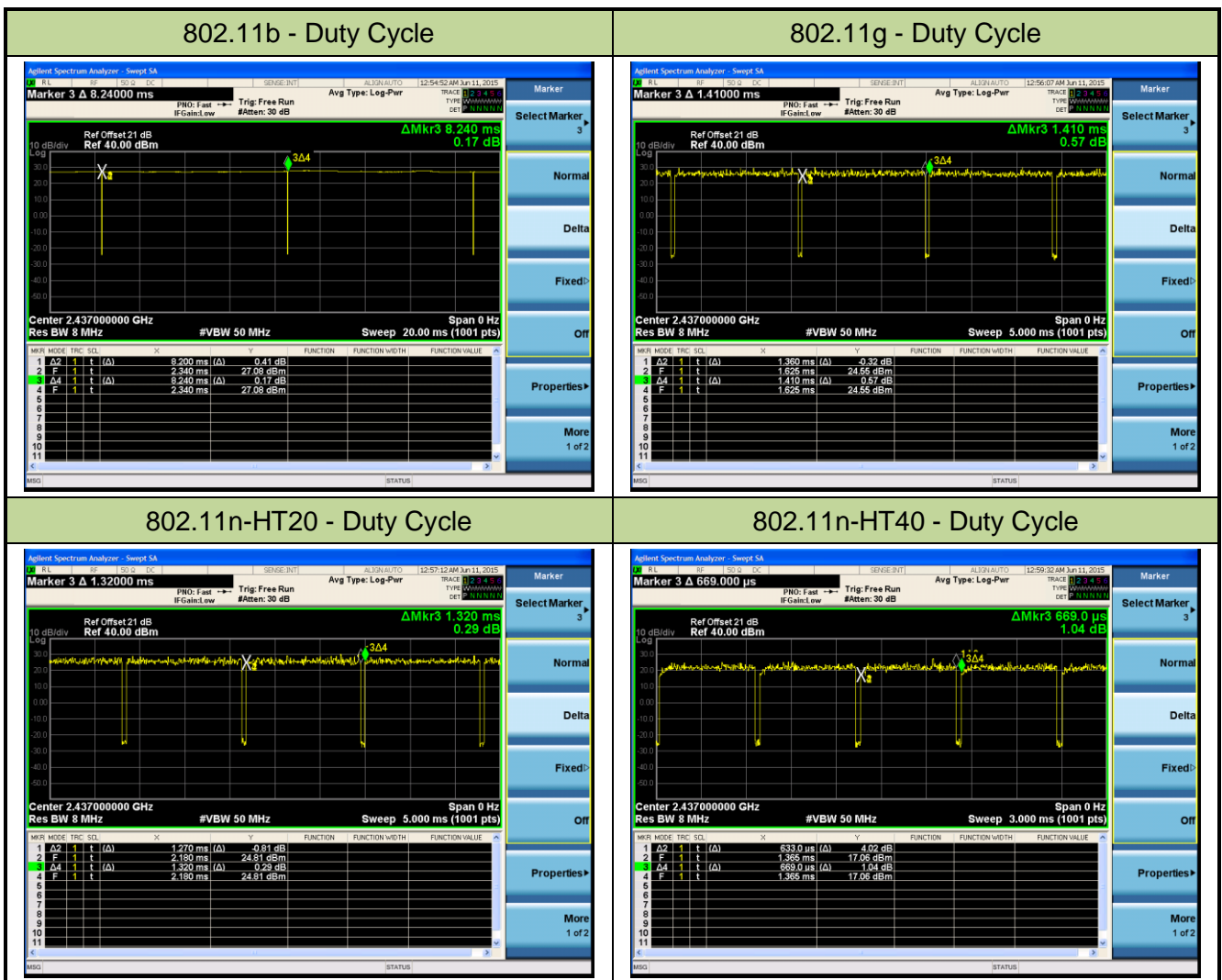

2.7. Test Configuration

The **Wireless Access Point FCC ID: 2AD8UFZCWI2A1, Model Number: WI2A-AC200i** was tested per the guidance of KDB 558074 D01v03r03. ANSI C63.10-2013 was used to reference the appropriate EUT setup for radiated spurious emissions testing and AC line conducted testing.

2.8. EMI Suppression Device(s)/Modifications

No EMI suppression device(s) were added and/or no modifications were made during testing.

2.9. Labeling Requirements

Per 2.1074 & 15.19; Docket 95-19

The label shall be permanently affixed at a conspicuous location on the device; instruction manual or pamphlet supplied to the user and be readily visible to the purchaser at the time of purchase.

However, when the device is so small wherein placement of the label with specified statement is not practical, only the trade name and FCC ID must be displayed on the device per Section 15.19(a)(5).

Please see attachment for FCC ID label and label location.

3. DESCRIPTION of TEST

3.1. Evaluation Procedure

The measurement procedures described in the American National Standard for Testing Unlicensed Wireless Devices (ANSI C63.10-2013), and the guidance provided in KDB 558074 D01v03r03 were used in the measurement of the **Wireless Access Point FCC ID: 2AD8UFZCWI2A1, Model Number: WI2A-AC200i.**

Deviation from measurement procedure.....None

3.2. AC Line Conducted Emissions

The line-conducted facility is located inside an 8'x4'x4' shielded enclosure. A 1m x 2m wooden table 80cm high is placed 40cm away from the vertical wall and 80cm away from the sidewall of the shielded room. Two 10kHz-30MHz, 50Ω/50uH Line-Impedance Stabilization Networks (LISNs) are bonded to the shielded room floor. Power to the LISNs is filtered by external high-current high-insertion loss power line filters. These filters attenuate ambient signal noise from entering the measurement lines. These filters are also bonded to the shielded enclosure.

The EUT is powered from one LISN and the support equipment is powered from the second LISN. All interconnecting cables more than 1 meter were shortened to a 1 meter length by non-inductive bundling (serpentine fashion) and draped over the back edge of the test table. All cables were at least 40cm above the horizontal reference ground-plane. Power cables for support equipment were routed down to the second LISN while ensuring that that cables were not draped over the second LISN.

Sufficient time for the EUT, support equipment, and test equipment was allowed in order for them to warm up to their normal operating condition. The RF output of the LISN was connected to the receiver and exploratory measurements were made to determine the frequencies producing the maximum emission from the EUT. The receiver was scanned from 150kHz to 30MHz. The detector function was set to peak mode for exploratory measurements while the bandwidth of the analyzer was set to 9kHz. The EUT, support equipment, and interconnecting cables were arranged and manipulated to maximize each emission. Each emission was also maximized by varying: power lines, the mode of operation or data exchange speed, or support equipment which determined the worst-case emission. Once the worst case emissions have been identified, the one EUT cable configuration/arrangement and mode of operation that produced these emissions are used for final measurements on the same test site. The analyzer is set to CISPR quasi-peak and average detectors with a 9kHz resolution bandwidth for final measurements.

An extension cord was used to connect to a single LISN which powered by EUT. The extension cord was calibrated with LISN, the impedance and insertion loss are compliance with the requirements as stated in ANSI C63.10-2013.

Line conducted emissions test results are shown in Section 7.8.

3.3. Radiated Emissions

The radiated test facilities consisted of an indoor 3 meter semi-anechoic chamber used for final measurements and exploratory measurements, when necessary. The measurement area is contained within the semi-anechoic chamber which is shielded from any ambient interference. For measurements above 1GHz absorbers are arranged on the floor between the turn table and the antenna mast in such a way so as to maximize the reduction of reflections. For measurements below 1GHz, the absorbers are removed. A MF Model 210SS turntable is used for radiated measurement. It is a continuously rotatable, remote controlled, metallic turntable and 2 meters (6.56 ft.) in diameter. The turn table is flush with the raised floor of the chamber in order to maintain its function as a ground plane. An 80cm high PVC support structure is placed on top of the turntable.

For all measurements, the spectrum was scanned through all EUT azimuths and from 1 to 4 meter receive antenna height using a broadband antenna from 30MHz up to the upper frequency shown in 15.33(b)(1) depending on the highest frequency generated or used in the device or on which the device operates or tunes. For frequencies above 1GHz, linearly polarized double ridge horn antennas were used. For frequencies below 30MHz, a calibrated loop antenna was used. When exploratory measurements were necessary, they were performed at 1 meter test distance inside the semi-anechoic chamber using broadband antennas, broadband amplifiers, and spectrum analyzers to determine the frequencies and modes producing the maximum emissions. Sufficient time for the EUT, support equipment, and test equipment was allowed in order for them to warm up to their normal operating condition. The test set-up for frequencies below 1GHz was placed on top of the 0.8 meter high, 1 x 1.5 meter table; and test set-up for frequencies 1-40GHz was placed on top of the 1.5 meter high, 1 x 1.5 meter table. The EUT, support equipment, and interconnecting cables were arranged and manipulated to maximize each emission. Appropriate precaution was taken to ensure that all emissions from the EUT were maximized and investigated. The system configuration, clock speed, mode of operation or video resolution, if applicable, turntable azimuth, and receive antenna height was noted for each frequency found.

Final measurements were made in the semi-anechoic chamber using calibrated, linearly polarized broadband and horn antennas. The test setup was configured to the setup that produced the worst case emissions. The spectrum analyzer was set to investigate all frequencies required for testing to compare the highest radiated disturbances with respect to the specified limits. The turntable containing the EUT was rotated through 360 degrees and the height of the receive antenna was varied 1 to 4 meters and stopped at the azimuth and height producing the maximum emission. Each emission was maximized by changing the orientation of the EUT through three orthogonal planes and changing the polarity of the receive antenna, which produced the worst-case emissions. According to 3dB Beam-Width of horn antenna, the horn antenna should be always directed to the EUT when rising height.

4. ANTENNA REQUIREMENTS

Excerpt from §15.203 of the FCC Rules/Regulations:

“An intentional radiator antenna shall be designed to ensure that no antenna other than that furnished by the responsible party can be used with the device. The use of a permanently attached antenna or of an antenna that uses a unique coupling to the intentional radiator shall be considered sufficient to comply with the provisions of this section.”

- The antenna of **Wireless Access Point** is **permanently attached**.
- There are no provisions for connection to an external antenna.

Conclusion:

The **Wireless Access Point FCC ID: 2AD8UFZCWI2A1, Model Number: WI2A-AC200i** unit complies with the requirement of §15.203.

5. TEST EQUIPMENT CALIBRATION DATE

Conducted Emissions

Instrument	Manufacturer	Type No.	Asset No.	Cali. Interval	Cali. Due Date
EMI Test Receiver	R&S	ESR7	MRTSUE06001	1 year	2015/11/07
Two-Line V-Network	R&S	ENV216	MRTSUE06002	1 year	2015/11/07
Two-Line V-Network	R&S	ENV216	MRTSUE06003	1 year	2015/11/07
Temperature/Humidity Meter	Ouleinuo	N/A	MRTSUE06114	1 year	2015/11/20

Radiated Emissions

Instrument	Manufacturer	Type No.	Asset No.	Cali. Interval	Cali. Due Date
Spectrum Analyzer	Agilent	E4447A	MRTSUE06028	1 year	2015/10/09
EMI Test Receiver	R&S	ESR7	MRTSUE06001	1 year	2015/11/07
Preamplifier	Agilent	83017A	MRTSUE06020	1 year	2015/12/13
Preamplifier	Schwarzbeck	BBV9721	MRTSUE06121	1 year	2016/04/15
Loop Antenna	Schwarzbeck	FMZB1519	MRTSUE06025	1 year	2015/11/08
TRILOG Antenna	Schwarzbeck	VULB9162	MRTSUE06022	1 year	2015/11/08
Broad-Band Horn Antenna	Schwarzbeck	BBHA9120D	MRTSUE06023	1 year	2015/11/08
Broadband Horn Antenna	Schwarzbeck	BBHA9170	MRTSUE06024	1 year	2016/01/05
Temperature/Humidity Meter	Ouleinuo	N/A	MRTSUE06115	1 year	2015/11/20

Conducted Test Equipment

Instrument	Manufacturer	Type No.	Asset No.	Cali. Interval	Cali. Due Date
Spectrum Analyzer	Agilent	N9020A	MRTSUE06106	1 year	2016/04/23
USB Wideband Power Sensor	Boonton	55006	MRTSUE06109	1 year	2015/10/15
Temperature/Humidity Meter	Ouleinuo	N/A	MRTSUE06112	1 year	2015/11/20

Software	Version	Function
e3	V8.3.5	EMI Test Software

6. MEASUREMENT UNCERTAINTY

Where relevant, the following test uncertainty levels have been estimated for tests performed on the EUT as specified in CISPR 16-4-2. This uncertainty represents an expanded uncertainty expressed at approximately the 95% confidence level using a coverage factor of $k = 2$.

AC Conducted Emission Measurement
Measuring Uncertainty for a Level of Confidence of 95% ($U=2Uc(y)$): 150kHz~30MHz: 3.46dB
Radiated Emission Measurement
Measuring Uncertainty for a Level of Confidence of 95% ($U=2Uc(y)$): 9kHz ~ 1GHz: 4.18dB 1GHz ~ 25GHz: 4.76dB

7. TEST RESULT

7.1. Summary

Product Name: Nokia Solutions and Networks
FCC ID: 2AD8UFZCWI2A1
IC: 109D-FZCWI2A01
Model No.: WI2A-AC200i
FCC Classification: Digital Transmission System (DTS)
Data Rate(s) Tested: 1Mbps ~ 11Mbps (b); 6Mbps ~ 54Mbps (g);
6.5/7.2Mbps ~ 130/144.4Mbps (n-HT20);
13.5/15Mbps ~ 270/300Mbps (n-HT40)

FCC Section(s)	IC Section(s)	Test Description	Test Limit	Test Condition	Test Result	Reference
15.247(a)(2)	RSS-247 [5.2]	6dB Bandwidth	$\geq 500\text{kHz}$	Conducted	Pass	Section 7.2
15.247(b)(3)	RSS-247 [5.4(4)]	Output Power	$\leq 30\text{dBm}$		Pass	Section 7.3
15.247(e)	RSS-247 [5.2]	Power Spectral Density	$\leq 8\text{dBm}/3\text{kHz}$		Pass	Section 7.4
15.247(d)	RSS-247 [5.5]	Band Edge / Out-of-Band Emissions	$\geq 30\text{dBc(Average)}$		Pass	Section 7.5
15.205 15.209	RSS-247 [5.5]	General Field Strength Limits (Restricted Bands and Radiated Emission Limits)	Emissions in restricted bands must meet the radiated limits detailed in 15.209	Radiated	Pass	Section 7.6 & 7.7
15.207	RSS-Gen [8.8]	AC Conducted Emissions 150kHz - 30MHz	< FCC 15.207 limits	Line Conducted	Pass	Section 7.8

Notes:

- 1) All modes of operation and data rates were investigated. For radiated emission test, every axis (X, Y, Z) was also verified. The test results shown in the following sections represent the worst case emissions.
- 2) The analyzer plots shown in this section were all taken with a correction table loaded into the analyzer. The correction table was used to account for the losses of the cables and attenuators used as part of the system to connect the EUT to the analyzer at all frequencies of interest.
- 3) All antenna port conducted emissions testing was performed on a test bench with the antenna port of the EUT connected to the spectrum analyzer through calibrated cables and attenuators.

- 4) Test Items “6dB Bandwidth” & “Band Edge / Out-of-Band Emissions” have been assessed single and MIMO transmission, and showed the worst test data in this report.

7.2. 6dB Bandwidth Measurement

7.2.1. Test Limit

The minimum 6dB bandwidth shall be at least 500 kHz.

7.2.2. Test Procedure used

KDB 558074 D01v03r03 - Section 8.2 Option 2

7.2.3. Test Setting

1. The Spectrum's automatic bandwidth measurement capability was used to perform the 6dB bandwidth measurement. The "X" dB bandwidth parameter was set to $X = 6$. The bandwidth measurement was not influenced by any intermediate power nulls in the fundamental emission.
2. Set RBW = 100 kHz
3. VBW $\geq 3 \times$ RBW
4. Detector = Peak
5. Trace mode = max hold
6. Sweep = auto couple
7. Allow the trace was allowed to stabilize

7.2.4. Test Setup

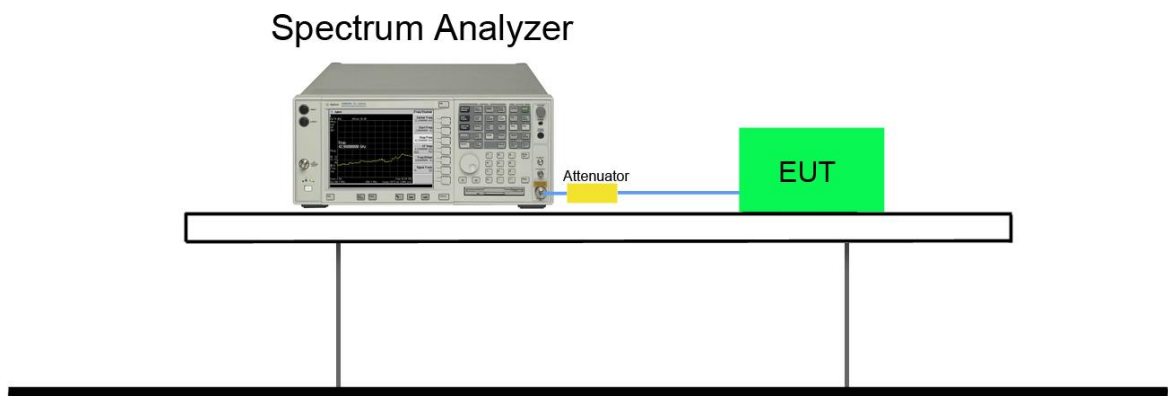

7.2.5. Test Result

Test Mode	Data Rate (Mbps)	Channel No.	Frequency (MHz)	6dB Bandwidth (MHz)	Limit (MHz)	Result
Ant 1						
802.11b	1	01	2412	7.11	≥0.5	Pass
802.11b	1	06	2437	7.11	≥0.5	Pass
802.11b	1	11	2462	7.12	≥0.5	Pass
802.11g	6	01	2412	16.40	≥0.5	Pass
802.11g	6	06	2437	16.41	≥0.5	Pass
802.11g	6	11	2462	16.38	≥0.5	Pass
802.11n-HT20	6.5	01	2412	17.60	≥0.5	Pass
802.11n-HT20	6.5	06	2437	17.61	≥0.5	Pass
802.11n-HT20	6.5	11	2462	17.61	≥0.5	Pass
802.11n-HT40	13.5	03	2422	36.41	≥0.5	Pass
802.11n-HT40	13.5	06	2437	36.09	≥0.5	Pass
802.11n-HT40	13.5	09	2452	35.60	≥0.5	Pass
Ant 2						
802.11b	1	01	2412	7.10	≥0.5	Pass
802.11b	1	06	2437	7.10	≥0.5	Pass
802.11b	1	11	2462	7.58	≥0.5	Pass
802.11g	6	01	2412	16.39	≥0.5	Pass
802.11g	6	06	2437	16.41	≥0.5	Pass
802.11g	6	11	2462	16.38	≥0.5	Pass
802.11n-HT20	6.5	01	2412	17.62	≥0.5	Pass
802.11n-HT20	6.5	06	2437	17.65	≥0.5	Pass
802.11n-HT20	6.5	11	2462	17.62	≥0.5	Pass
802.11n-HT40	13.5	03	2422	36.39	≥0.5	Pass
802.11n-HT40	13.5	06	2437	36.46	≥0.5	Pass
802.11n-HT40	13.5	09	2452	36.33	≥0.5	Pass

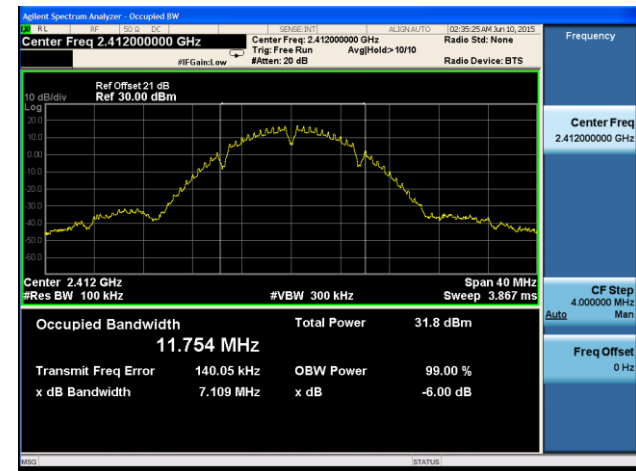
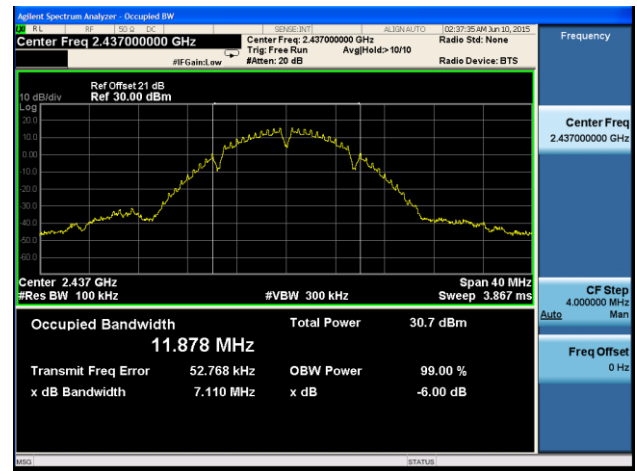
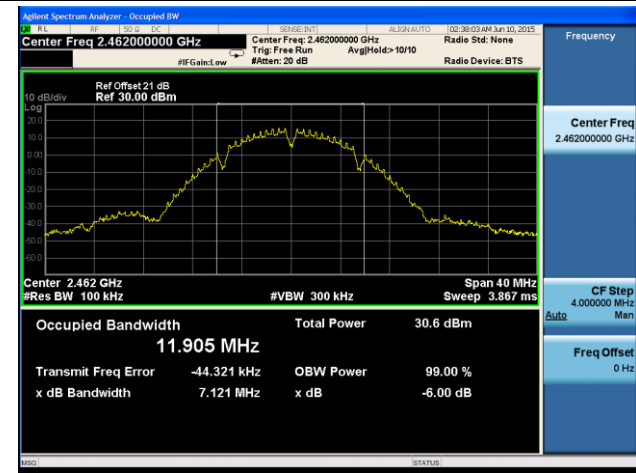
802.11b 6dB Bandwidth - Ant 1
Channel 01 (2412MHz)

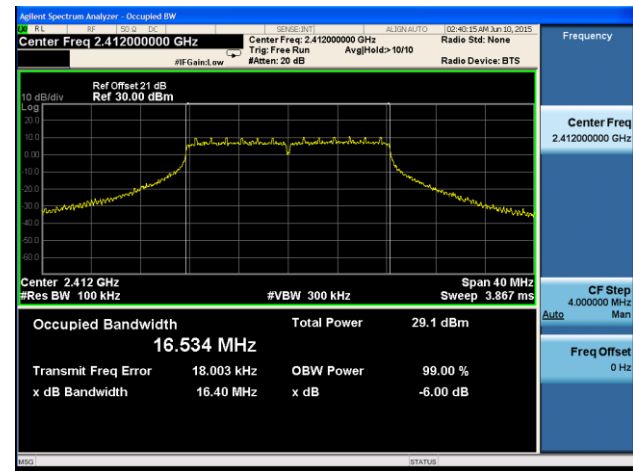
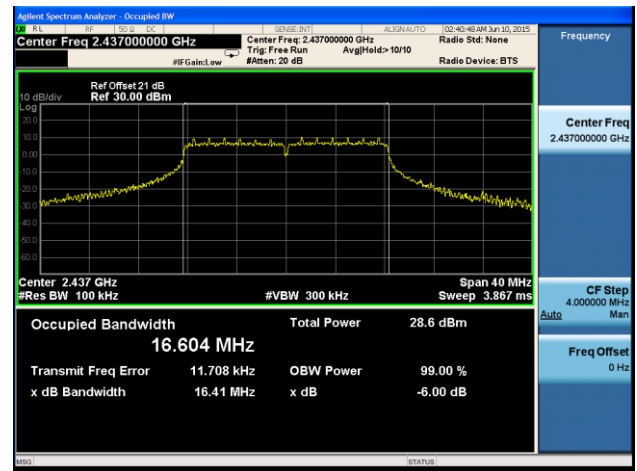
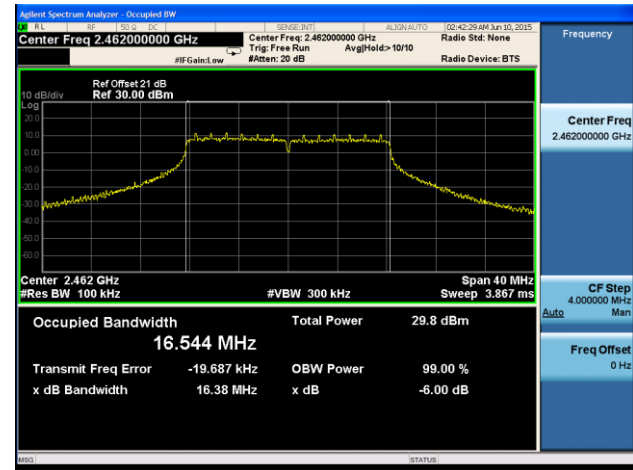
Channel 06 (2437MHz)

Channel 11 (2462MHz)

802.11g 6dB Bandwidth - Ant 1
Channel 01 (2412MHz)

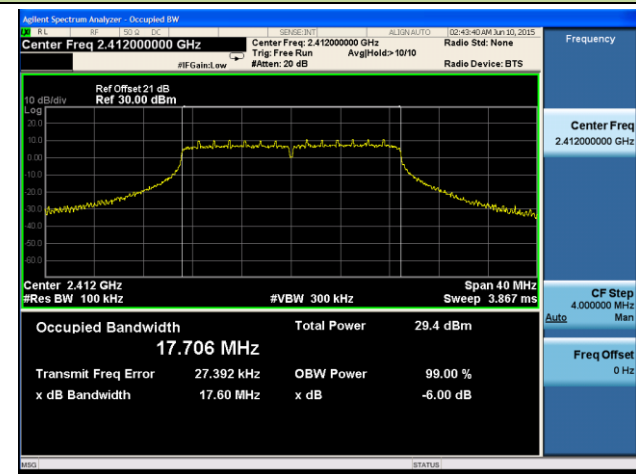
Channel 06 (2437MHz)

Channel 11 (2462MHz)

802.11n-HT20 6dB Bandwidth - Ant 1

Channel 01 (2412MHz)

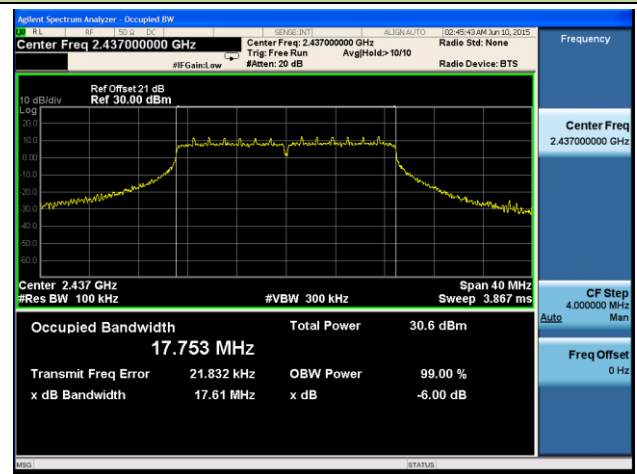

Channel 06 (2437MHz)



Channel 11 (2462MHz)

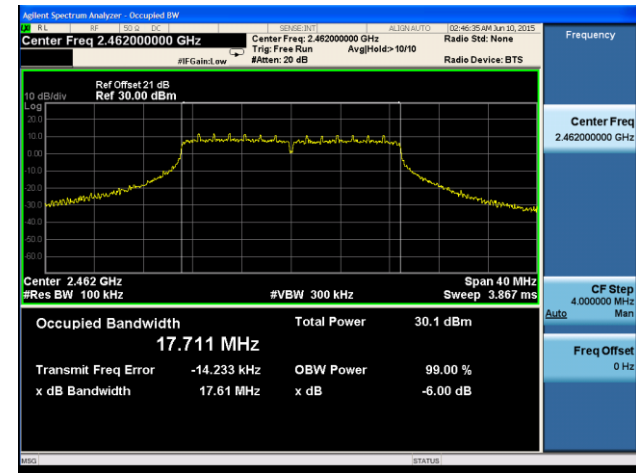

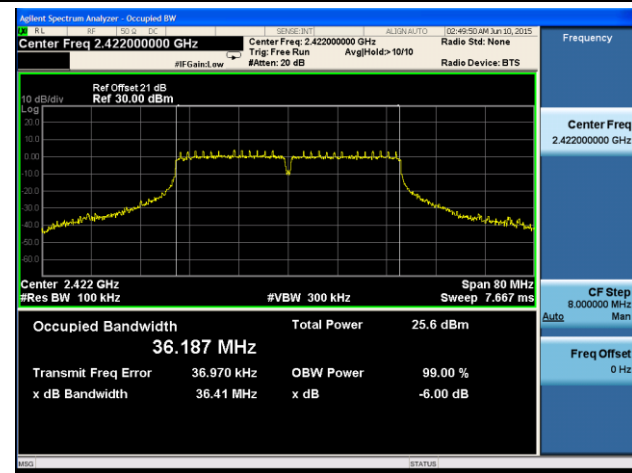
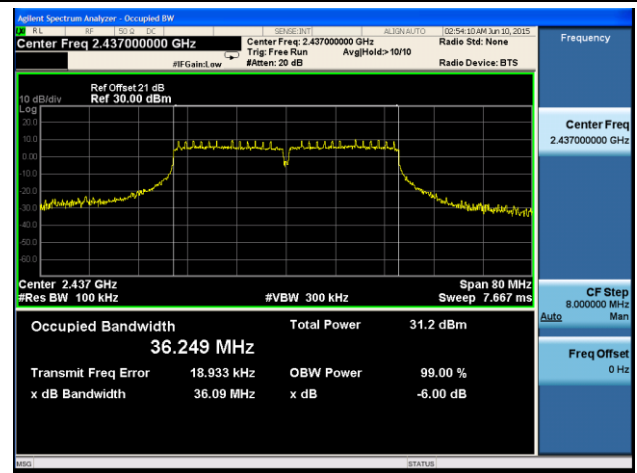
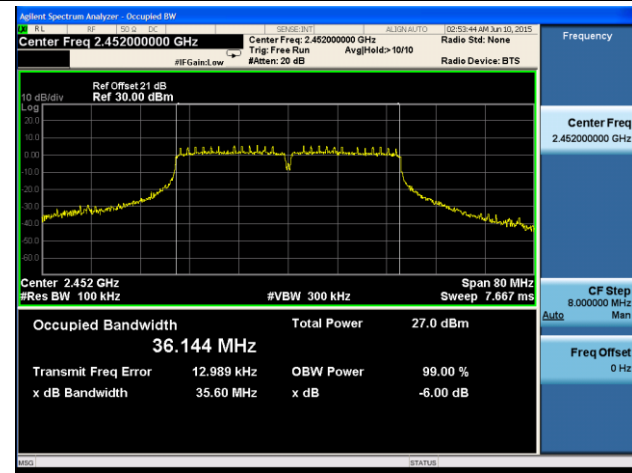
802.11n-HT40 6dB Bandwidth - Ant 1
Channel 03 (2422MHz)

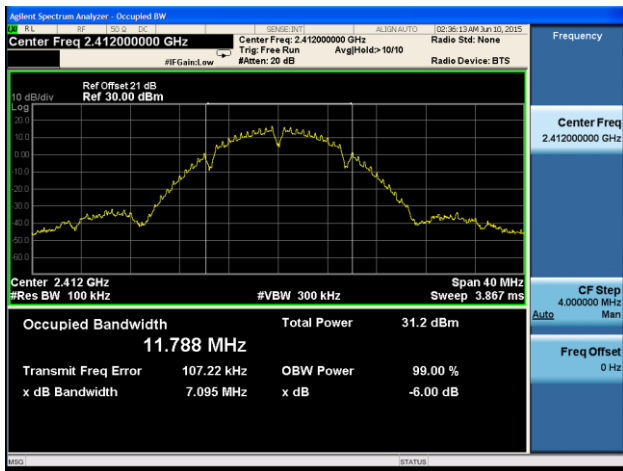
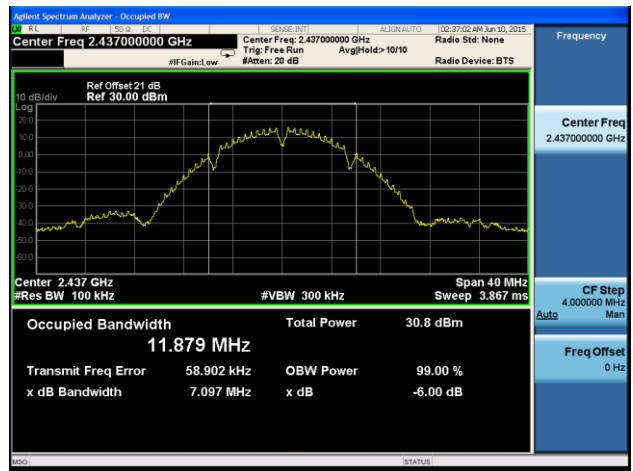
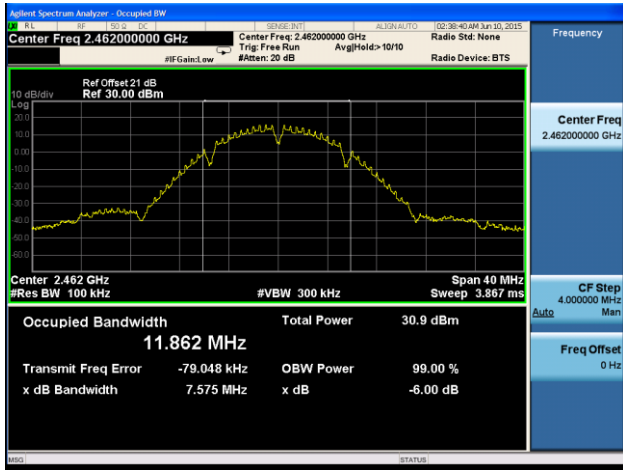
Channel 06 (2437MHz)

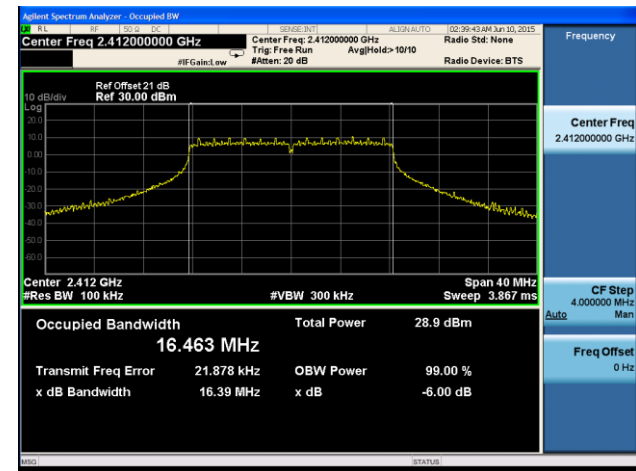
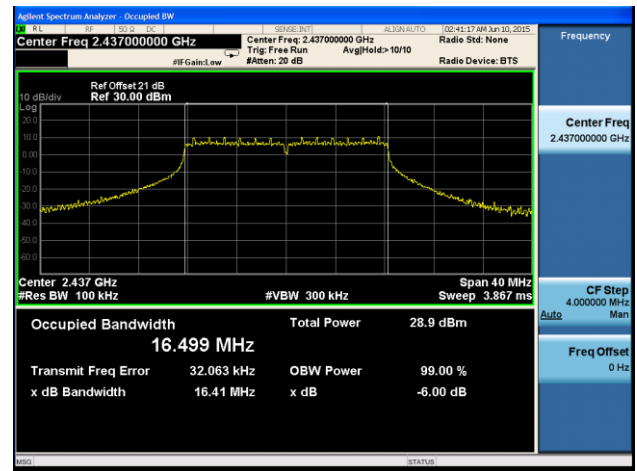
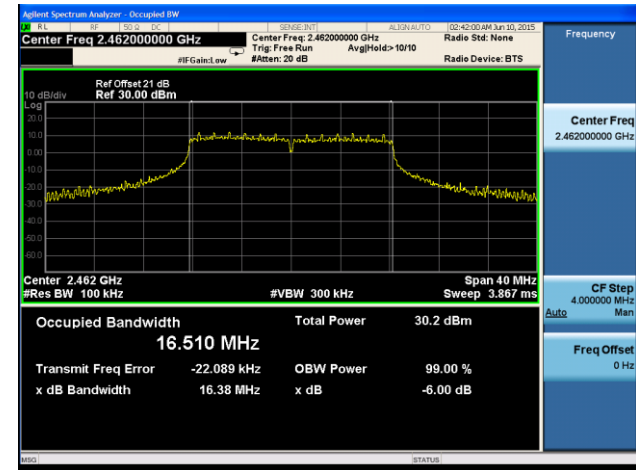
Channel 09 (2452MHz)

802.11b 6dB Bandwidth - Ant 2
Channel 01 (2412MHz)

Channel 06 (2437MHz)

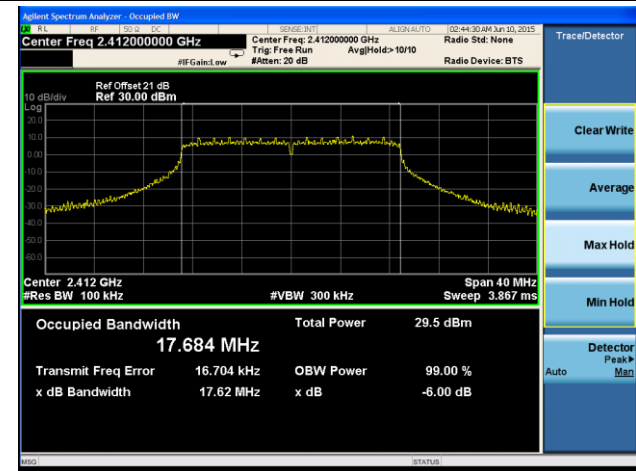
Channel 11 (2462MHz)

802.11g 6dB Bandwidth - Ant 2
Channel 01 (2412MHz)

Channel 06 (2437MHz)

Channel 11 (2462MHz)

802.11n-HT20 6dB Bandwidth - Ant 2

Channel 01 (2412MHz)

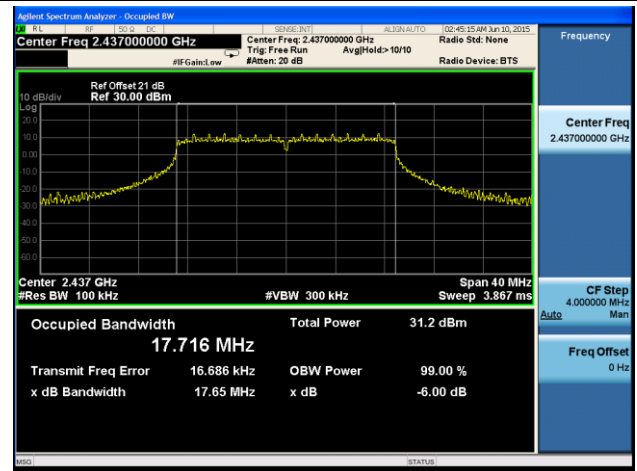

Channel 06 (2437MHz)



Channel 11 (2462MHz)

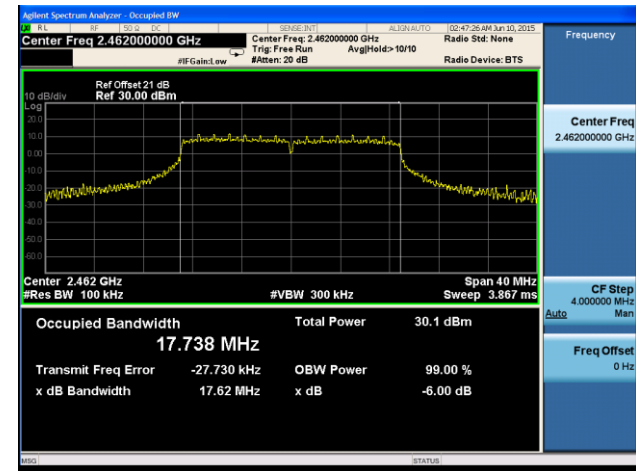

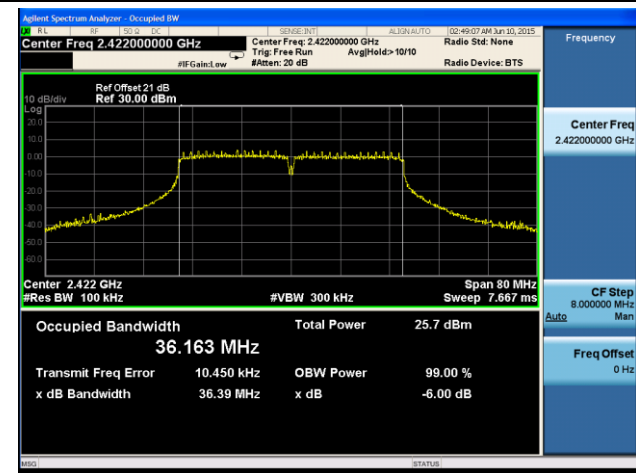
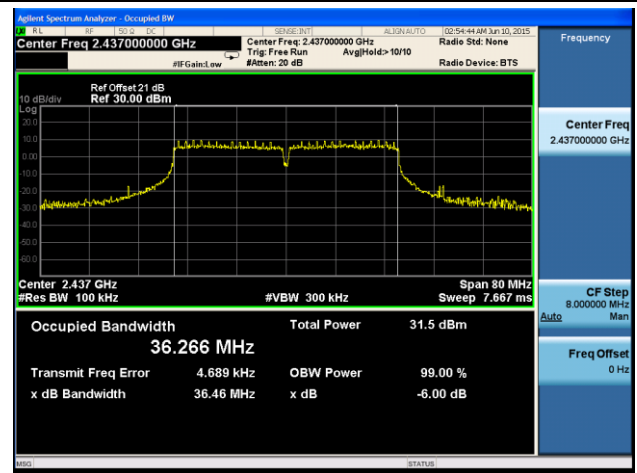
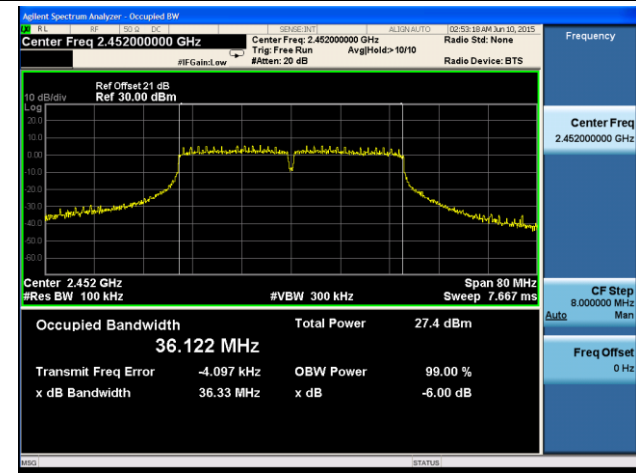
802.11n-HT40 6dB Bandwidth - Ant 2
Channel 03 (2422MHz)

Channel 06 (2437MHz)

Channel 09 (2452MHz)

7.3. Output Power Measurement

7.3.1. Test Limit

The maximum out power shall be less 1 Watt (30dBm).

7.3.2. Test Procedure Used

KDB 558074 D01v03r03 - Section 9.2.3.2 AVGPM-G Average Power Method

7.3.3. Test Setting

Average Power Measurement

Average power measurements were perform only when the EUT was transmitting at its maximum power control level using a broadband power meter with a pulse sensor. The power meter implemented triggering and gating capabilities which were set up such that power measurements were recorded only during the ON time of the transmitter. The trace was averaged over 100 traces to obtain the final measured average power.

7.3.4. Test Setup

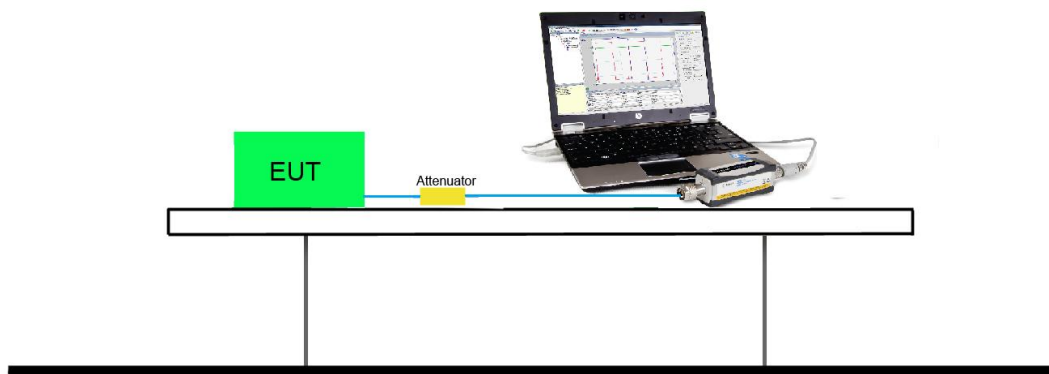

7.3.5. Test Result of Output Power

Power output test was verified over all data rates of each mode shown as below, and then choose the maximum power output (yellow marker) for final test of each channel.

N _{TX}	Data Rate (Mbps)						
	802.11b	802.11g	MCS Index for 802.11n	20MHz Bandwidth		40MHz Bandwidth	
				800ns GI	400ns GI	800ns GI	400ns GI
1	1	6	0	6.5	7.2	13.5	15.0
1	2	9	1	13.0	14.4	27.0	30.0
1	5.5	12	2	19.5	21.7	40.5	45.0
1	11	18	3	26.0	28.9	54.0	60.0
1	--	24	4	39.0	43.3	81.0	90.0
1	--	36	5	52.0	57.8	108.0	120.0
1	--	48	6	58.5	65.0	121.5	135.0
1	--	54	7	65.0	72.2	135.0	150.0
2	--	--	8	13.0	14.4	27.0	30.0
2	--	--	9	26.0	28.9	54.0	60.0
2	--	--	10	39.0	43.3	81.0	90.0
2	--	--	11	52.0	57.8	108.0	120.0
2	--	--	12	78.0	86.7	162.0	180.0
2	--	--	13	104.0	115.6	216.0	240.0
2	--	--	14	117.0	130.0	243.0	270.0
2	--	--	15	130.0	144.0	270.0	300.0

Output power at various data rates for Ant 1:

Test Mode	Bandwidth (MHz)	Channel No.	Frequency (MHz)	Data Rate (Mbps)	Average Power (dBm)
802.11b	20	6	2437	1	22.53
				5.5	22.31
				11	22.01
802.11g	20	6	2437	6	22.73
				24	22.19
				54	21.82
802.11n	20	6	2437	6.5	22.67
				7.2	22.48
				52	22.32
				57.8	22.19
				65	22.02
				72.2	21.75
802.11n	40	6	2437	13.5	22.31
				15	22.18
				54	22.03
				60	21.85
				135	21.58
				150	21.36

Test Result of Average Output Power

Test Mode	Data Rate (Mbps)	Channel No.	Freq. (MHz)	Ant 1 Average Power (dBm)	Ant 2 Average Power (dBm)	Total Average Power (dBm)	Limit (dBm)	Result
Ant 1								
11b	1	1	2412	23.15	--	23.15	≤30	Pass
11b	1	6	2437	22.53	--	22.53	≤30	Pass
11b	1	11	2462	22.43	--	22.43	≤30	Pass
11g	6	1	2412	21.98	--	21.98	≤30	Pass
11g	6	6	2437	22.73	--	22.73	≤30	Pass
11g	6	11	2462	22.67	--	22.67	≤30	Pass
11n-HT20	6.5	1	2412	22.17	--	22.17	≤30	Pass
11n-HT20	6.5	6	2437	22.67	--	22.67	≤30	Pass
11n-HT20	6.5	11	2462	21.50	--	21.50	≤30	Pass
11n-HT40	13.5	3	2422	17.64	--	17.64	≤30	Pass
11n-HT40	13.5	6	2437	22.31	--	22.31	≤30	Pass
11n-HT40	13.5	9	2452	17.19	--	17.19	≤30	Pass
Ant 2								
11b	1	1	2412	--	23.29	23.29	≤30	Pass
11b	1	6	2437	--	22.91	22.91	≤30	Pass
11b	1	11	2462	--	22.43	22.43	≤30	Pass
11g	6	1	2412	--	22.85	22.85	≤30	Pass
11g	6	6	2437	--	22.72	22.72	≤30	Pass
11g	6	11	2462	--	22.38	22.38	≤30	Pass
11n-HT20	6.5	1	2412	--	21.98	21.98	≤30	Pass
11n-HT20	6.5	6	2437	--	22.64	22.64	≤30	Pass
11n-HT20	6.5	11	2462	--	22.45	22.45	≤30	Pass
11n-HT40	13.5	3	2422	--	18.72	18.72	≤30	Pass
11n-HT40	13.5	6	2437	--	22.78	22.78	≤30	Pass
11n-HT40	13.5	9	2452	--	19.55	19.55	≤30	Pass

Test Mode	Data Rate (Mbps)	Channel No.	Freq. (MHz)	Ant 1 Average Power (dBm)	Ant 2 Average Power (dBm)	Total Average Power (dBm)	Limit (dBm)	Result
Ant 1 + 2								
11b	1	1	2412	23.45	23.24	26.36	≤30	Pass
11b	1	6	2437	22.77	22.81	25.80	≤30	Pass
11b	1	11	2462	22.62	22.61	25.63	≤30	Pass
11g	6	1	2412	21.17	20.94	24.07	≤30	Pass
11g	6	6	2437	22.39	22.56	25.49	≤30	Pass
11g	6	11	2462	21.46	21.67	24.58	≤30	Pass
11n-HT20	13	1	2412	20.98	20.84	23.92	≤30	Pass
11n-HT20	13	6	2437	22.35	22.41	25.39	≤30	Pass
11n-HT20	13	11	2462	21.49	21.57	24.54	≤30	Pass
11n-HT40	27	3	2422	16.53	16.24	19.40	≤30	Pass
11n-HT40	27	6	2437	22.20	22.69	25.46	≤30	Pass
11n-HT40	27	9	2452	18.12	18.49	21.32	≤30	Pass

Note: Total Average Power (dBm) = $10 \cdot \log\{10^{(\text{Ant 1 Average Power}/10)} + 10^{(\text{Ant 2 Average Power}/10)}\}$ (dBm).

7.4. Power Spectral Density Measurement

7.4.1. Test Limit

The maximum permissible power spectral density is 8dBm in any 3 kHz band.

7.4.2. Test Procedure Used

KDB 558074 D01v03r03 - Section 10.5 Method AVGPSD

7.4.3. Test Setting

1. Measure the duty cycle (x) of the transmitter output signal
2. Set instrument center frequency to DTS channel center frequency.
3. Set span to at least 1.5 times the OBW.
4. RBW = 3kHz
5. VBW = 10kHz
6. Detector = RMS
7. Ensure that the number of measurement points in the sweep $\geq 2 \times \text{span}/\text{RBW}$.
8. Sweep time = auto couple
9. Don't use sweep triggering. Allow sweep to "free run".
10. Employ trace averaging (RMS) mode over a minimum of 100 traces.
11. Use the peak marker function to determine the maximum amplitude level.
12. Add $10 \log(1/x)$, where x is the duty cycle measured in step (a, to the measured PSD to compute the average PSD during the actual transmission time.

7.4.4. Test Setup

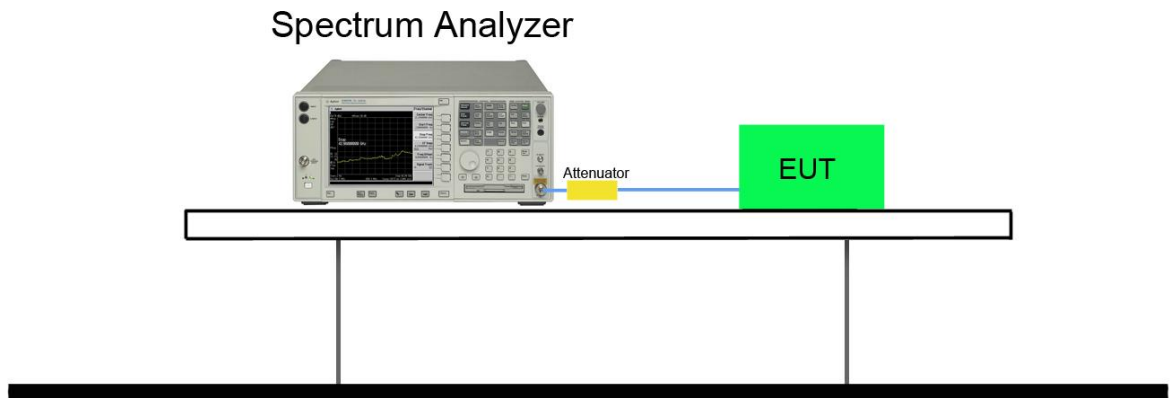

7.4.5. Test Result

Test Mode	Data Rate (Mbps)	Channel No.	Freq. (MHz)	Ant 1 AVGPSD (dBm / 10kHz)	Ant 2 AVGPSD (dBm / 10kHz)	Duty Cycle (%)	Total AVGPSD (dBm / 3kHz)	Limit (dBm / 3kHz)	Result
Ant 1									
11b	1	1	2412	-9.19	--	99.51	-9.19	≤8.0	Pass
11b	1	6	2437	-10.20	--	99.51	-10.20	≤8.0	Pass
11b	1	11	2462	-9.15	--	99.51	-9.15	≤8.0	Pass
11g	6	1	2412	-12.29	--	96.45	-12.13	≤8.0	Pass
11g	6	6	2437	-11.97	--	96.45	-11.81	≤8.0	Pass
11g	6	11	2462	-11.04	--	96.45	-10.88	≤8.0	Pass
11n-HT20	6.5	1	2412	-12.15	--	96.21	-11.98	≤8.0	Pass
11n-HT20	6.5	6	2437	-12.28	--	96.21	-12.11	≤8.0	Pass
11n-HT20	6.5	11	2462	-12.03	--	96.21	-11.86	≤8.0	Pass
11n-HT40	13.5	3	2422	-19.17	--	94.62	-18.93	≤8.0	Pass
11n-HT40	13.5	6	2437	-14.73	--	94.62	-14.49	≤8.0	Pass
11n-HT40	13.5	9	2452	-19.30	--	94.62	-19.06	≤8.0	Pass
Ant 2									
11b	1	1	2412	--	-8.98	99.51	-8.98	≤8.0	Pass
11b	1	6	2437	--	-9.27	99.51	-9.27	≤8.0	Pass
11b	1	11	2462	--	-9.28	99.51	-9.28	≤8.0	Pass
11g	6	1	2412	--	-11.63	96.45	-11.47	≤8.0	Pass
11g	6	6	2437	--	-11.43	96.45	-11.27	≤8.0	Pass
11g	6	11	2462	--	-11.33	96.45	-11.17	≤8.0	Pass
11n-HT20	6.5	1	2412	--	-12.67	96.21	-12.50	≤8.0	Pass
11n-HT20	6.5	6	2437	--	-11.83	96.21	-11.66	≤8.0	Pass
11n-HT20	6.5	11	2462	--	-11.08	96.21	-10.91	≤8.0	Pass
11n-HT40	13.5	3	2422	--	-18.69	94.62	-18.45	≤8.0	Pass
11n-HT40	13.5	6	2437	--	-14.71	94.62	-14.47	≤8.0	Pass
11n-HT40	13.5	9	2452	--	-17.26	94.62	-17.02	≤8.0	Pass

Test Mode	Data Rate (Mbps)	Channel No.	Freq. (MHz)	Ant 1 AVGPSD (dBm / 10kHz)	Ant 2 AVGPSD (dBm / 10kHz)	Duty Cycle (%)	Total AVGPSD (dBm / 3kHz)	Limit (dBm / 3kHz)	Result
Ant 1 + 2									
11b	1	1	2412	-9.19	-9.29	99.51	-6.23	≤8.0	Pass
11b	1	6	2437	-9.94	-9.37	99.51	-6.64	≤8.0	Pass
11b	1	11	2462	-9.26	-10.03	99.51	-6.62	≤8.0	Pass
11g	6	1	2412	-13.47	-13.69	96.45	-10.41	≤8.0	Pass
11g	6	6	2437	-12.37	-11.61	96.45	-8.81	≤8.0	Pass
11g	6	11	2462	-12.05	-12.14	96.45	-8.93	≤8.0	Pass
11n-HT20	13	1	2412	-13.44	-13.29	96.21	-10.19	≤8.0	Pass
11n-HT20	13	6	2437	-12.38	-10.98	96.21	-8.45	≤8.0	Pass
11n-HT20	13	11	2462	-11.78	-12.02	96.21	-8.72	≤8.0	Pass
11n-HT40	27	3	2422	-20.28	-19.77	94.62	-16.77	≤8.0	Pass
11n-HT40	27	6	2437	-14.94	-13.46	94.62	-10.89	≤8.0	Pass
11n-HT40	27	9	2452	-17.54	-17.90	94.62	-14.47	≤8.0	Pass

Note 1: When EUT duty cycle < 98%, the total AVGPSD = $10 \cdot \log\{10^{(\text{Ant 1 AVGPSD}/10)} + 10^{(\text{Ant 2 AVGPSD}/10)}\} + 10 \cdot \log(1/\text{duty cycle})$.

Note 2: When EUT duty cycle > 98%, the total AVGPSD = $10 \cdot \log\{10^{(\text{Ant 1 AVGPSD}/10)} + 10^{(\text{Ant 2 AVGPSD}/10)}\}$.

802.11b AVGPSD - Ant 1

Channel 01 (2412MHz)

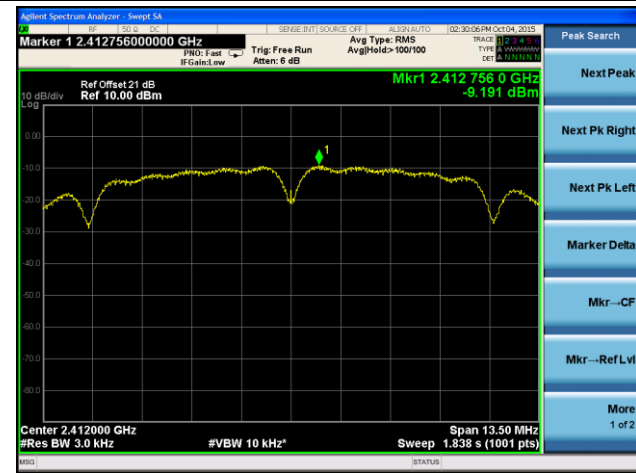

Channel 06 (2437MHz)



Channel 11 (2462MHz)



802.11g AVGPDS - Ant 1

Channel 01 (2412MHz)

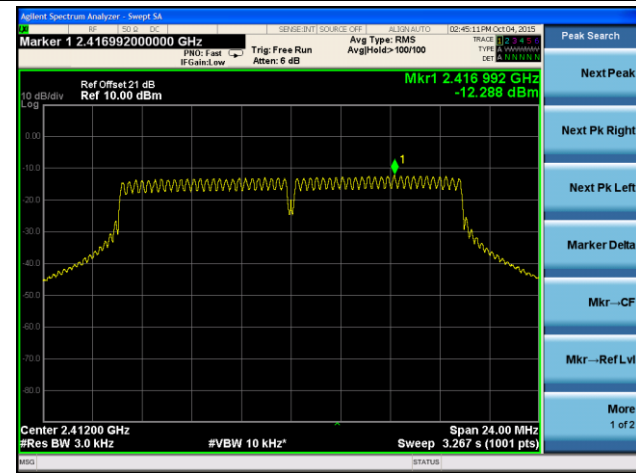

Channel 06 (2437MHz)

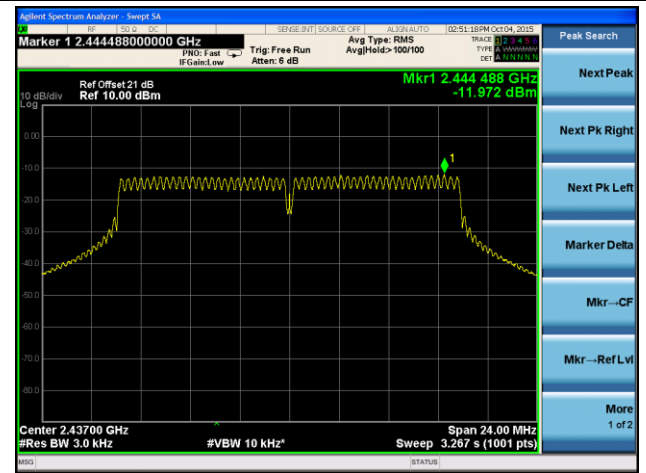

Channel 11 (2462MHz)

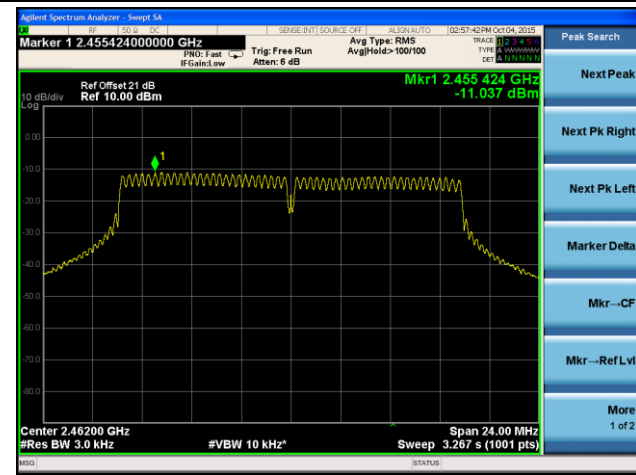

802.11n-HT20 AVGPDS - Ant 1

Channel 01 (2412MHz)

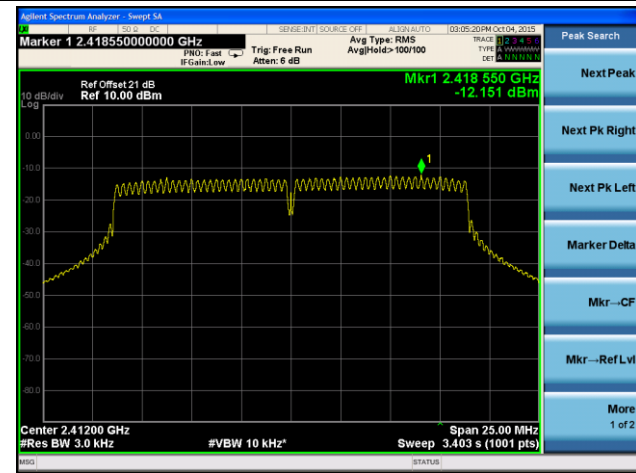

Channel 06 (2437MHz)

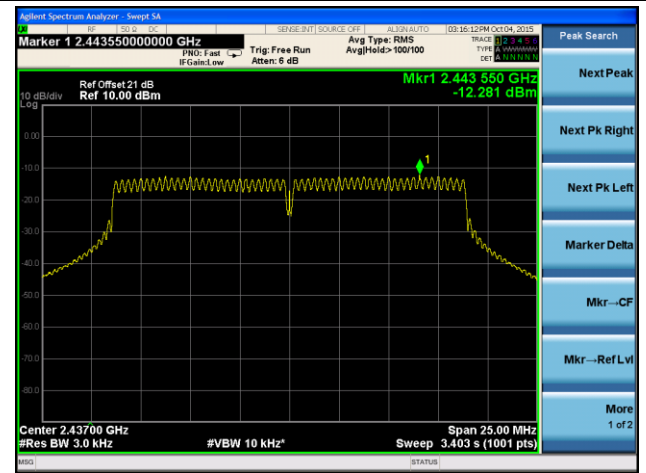

Channel 11 (2462MHz)

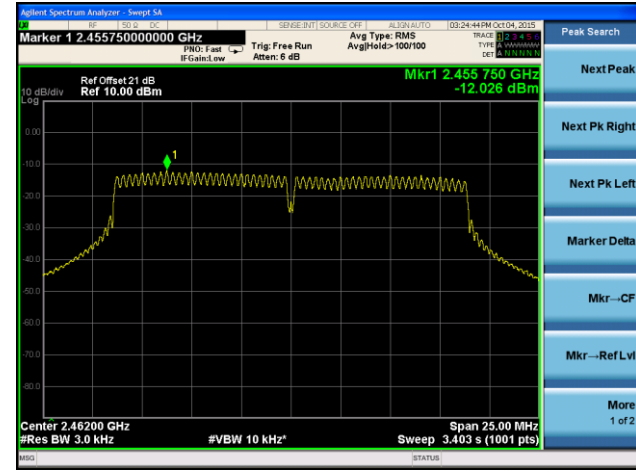

802.11n-HT40 AVGPSD - Ant 1

Channel 03 (2422MHz)

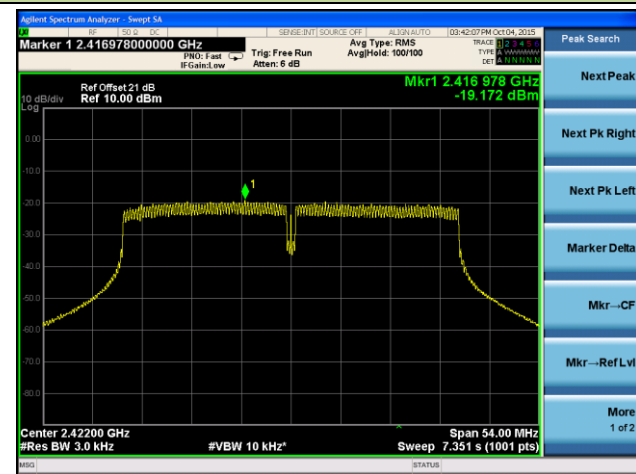

Channel 06 (2437MHz)

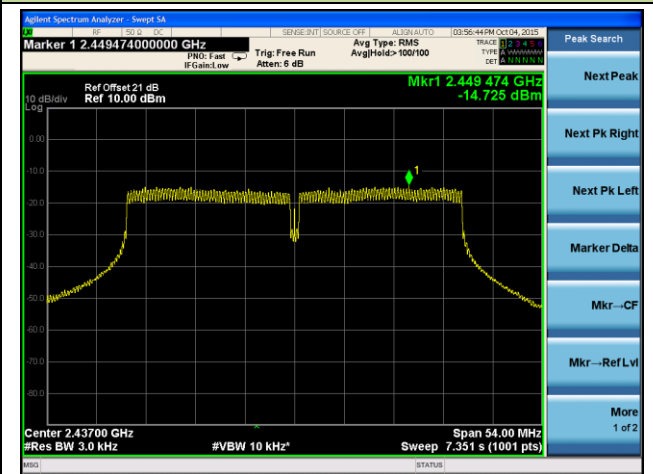

Channel 09 (2452MHz)

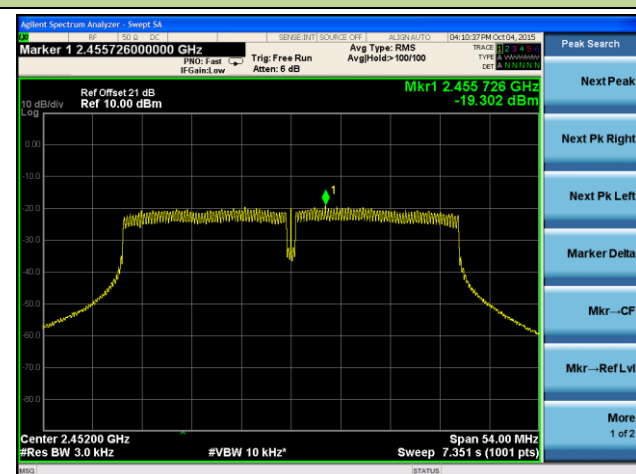

802.11b AVGPDS - Ant 2

Channel 01 (2412MHz)



Channel 06 (2437MHz)

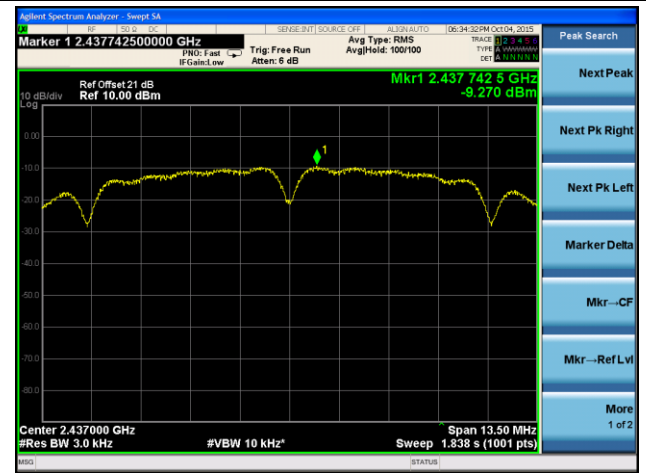

Channel 11 (2462MHz)



802.11g AVGPDS - Ant 2

Channel 01 (2412MHz)

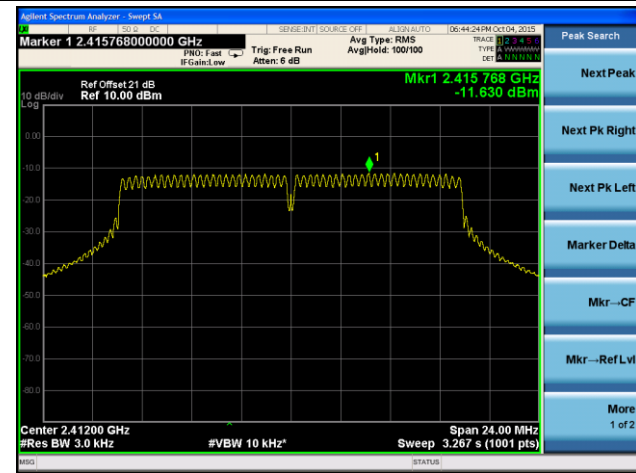

Channel 06 (2437MHz)

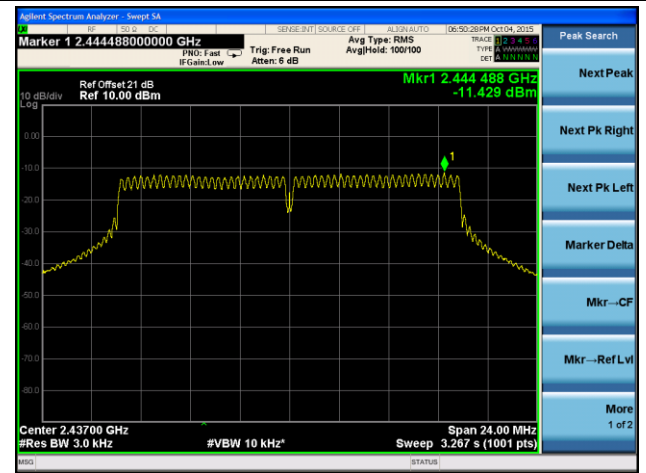

Channel 11 (2462MHz)

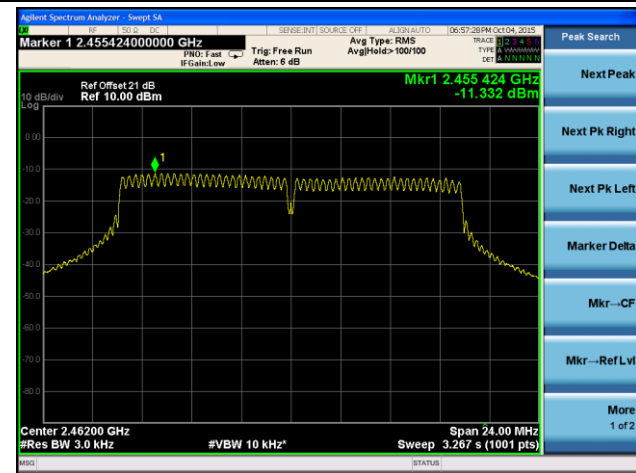

802.11n-HT20 AVGPDS - Ant 2

Channel 01 (2412MHz)

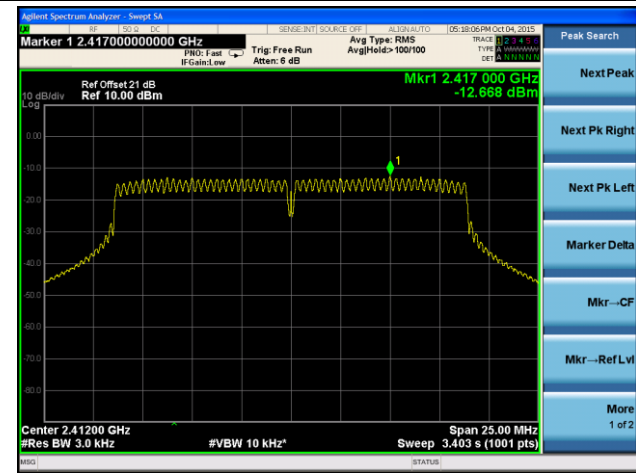

Channel 06 (2437MHz)

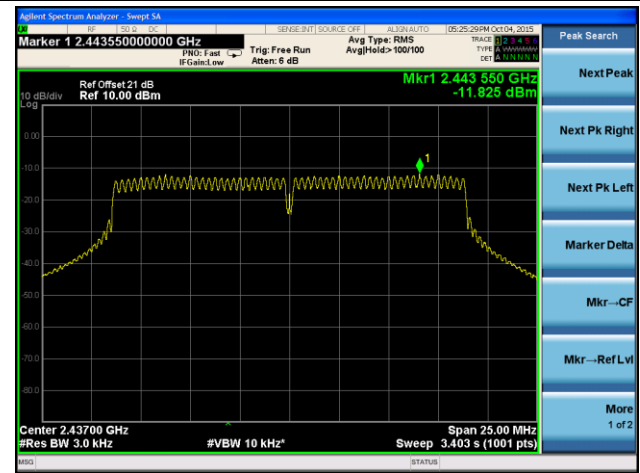

Channel 11 (2462MHz)

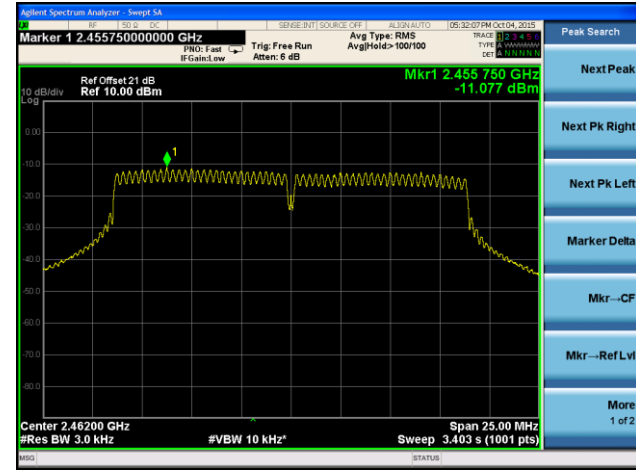

802.11n-HT40 AVGPSD - Ant 2

Channel 03 (2422MHz)

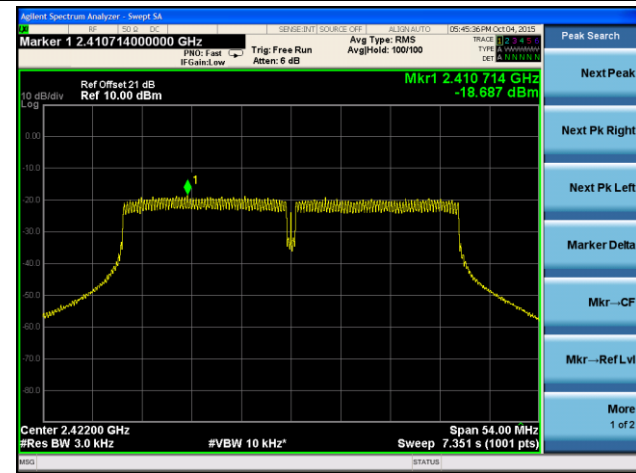

Channel 06 (2437MHz)

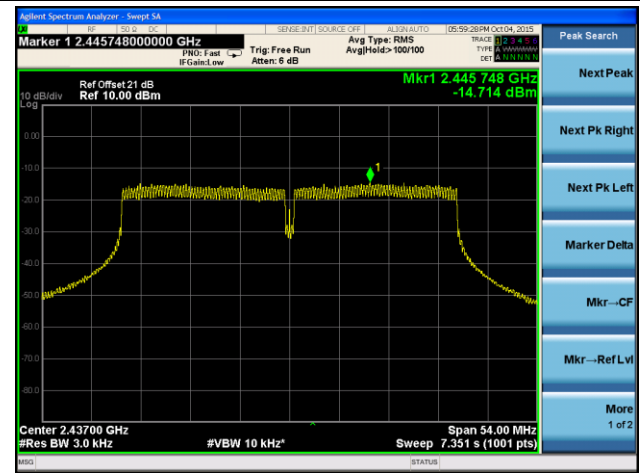

Channel 09 (2452MHz)

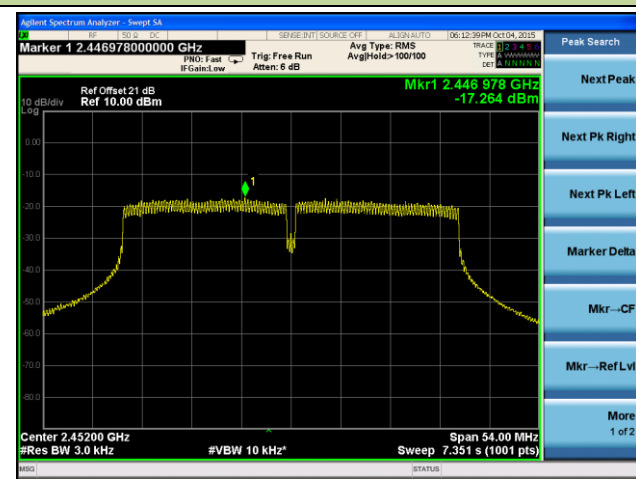

802.11b AVGPDS - Ant 1 / Ant 1 + 2

Channel 01 (2412MHz)



Channel 06 (2437MHz)



Channel 11 (2462MHz)

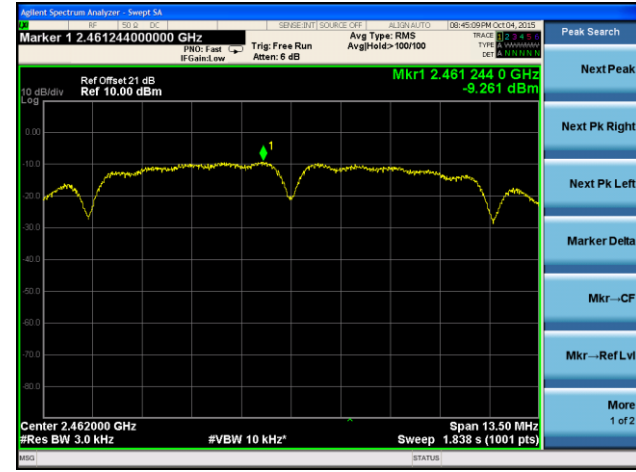

802.11g AVGPDS - Ant 1 / Ant 1 + 2

Channel 01 (2412MHz)

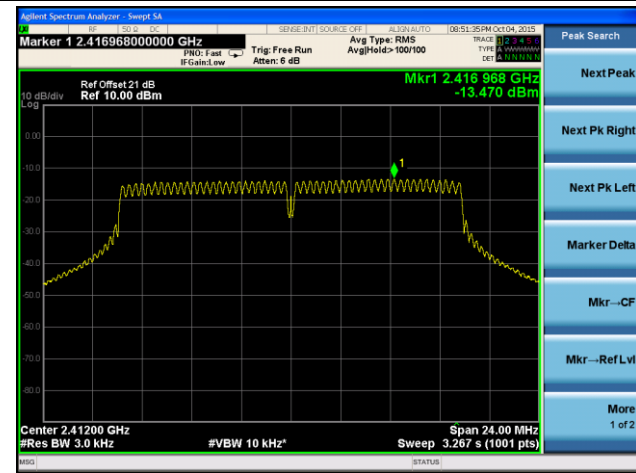

Channel 06 (2437MHz)

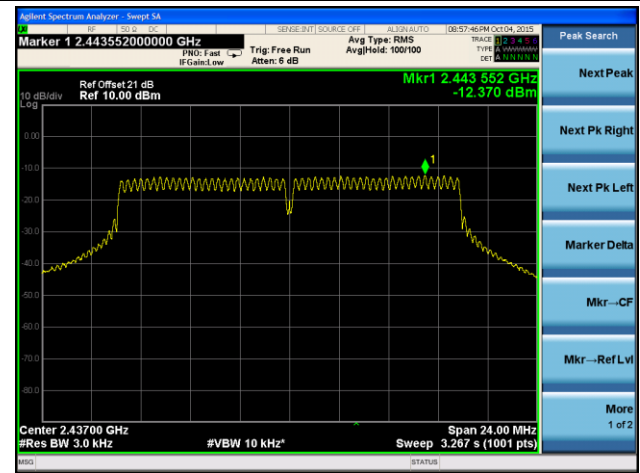

Channel 11 (2462MHz)

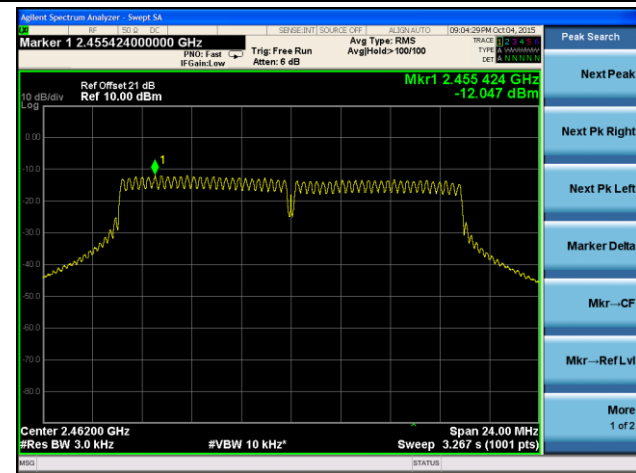

802.11n-HT20 AVGPDS - Ant 1 / Ant 1 + 2

Channel 01 (2412MHz)

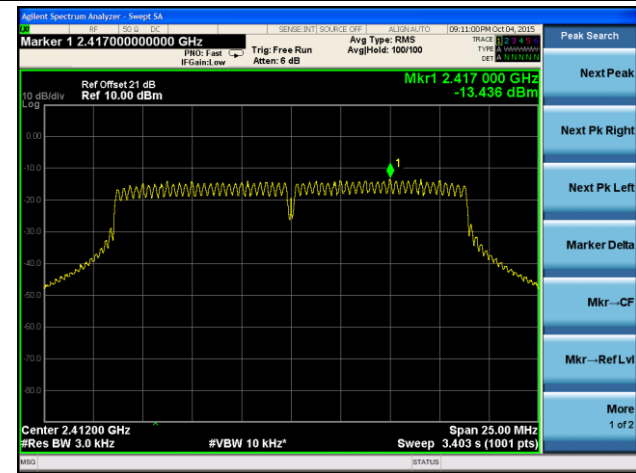

Channel 06 (2437MHz)

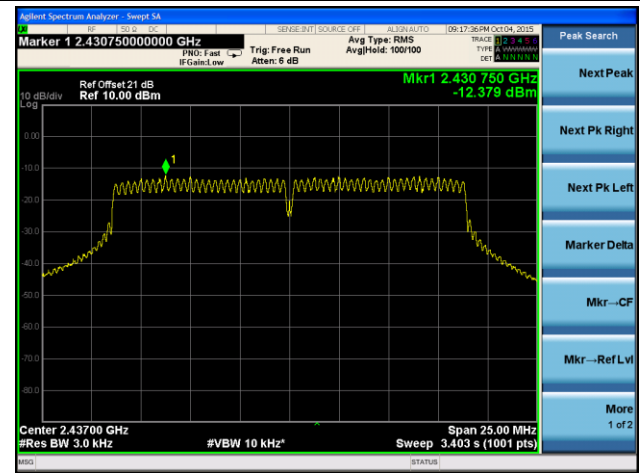

Channel 11 (2462MHz)

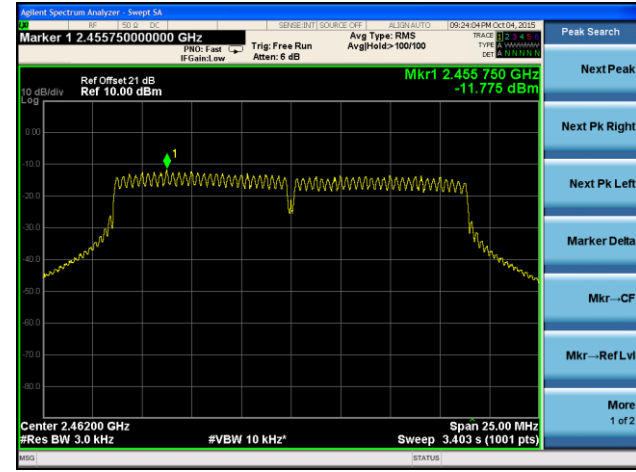

802.11n-HT40 AVGPSD - Ant 1 / Ant 1 + 2

Channel 03 (2422MHz)

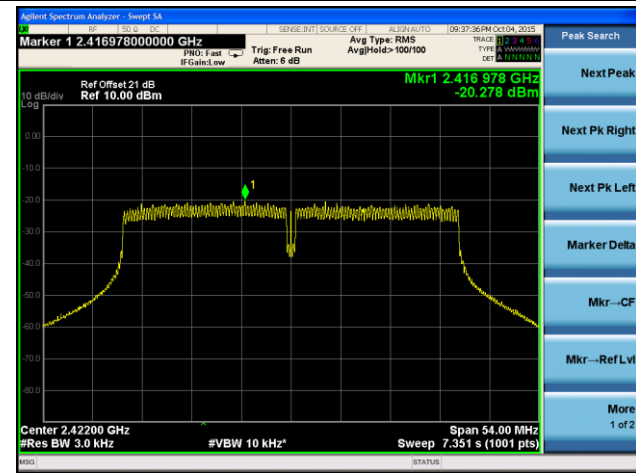

Channel 06 (2437MHz)

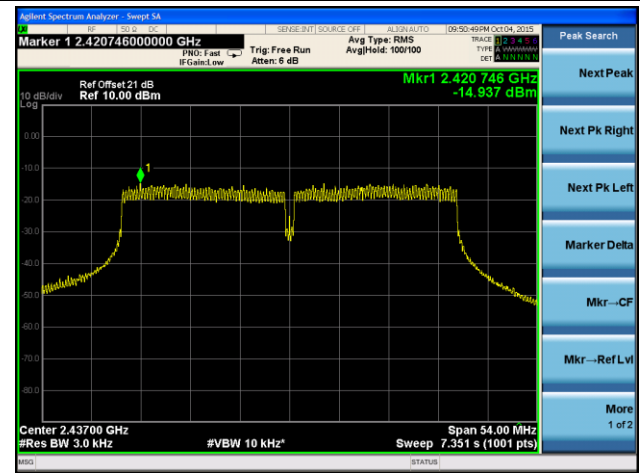

Channel 09 (2452MHz)

