

FCC Test Report

(PART 27)

Report No.: RF161222C05

FCC ID: 2AD8UFW2HBDPM01

Test Model: FW2HBDPM01

Received Date: Dec. 22, 2017

Test Date: Jan. 11, 2017 ~ Jan. 21, 2017

Issued Date: Jan. 26, 2017

Applicant: Nokia Solutions and Networks

Address: 1455 West Shure Drive, Arlington Heights, IL 60004, USA

Issued By: Bureau Veritas Consumer Products Services (H.K.) Ltd., Taoyuan Branch

Lab Address: No. 47-2, 14th Ling, Chia Pau Vil., Lin Kou Dist., New Taipei City, Taiwan
(R.O.C)

Test Location: No. 19, Hwa Ya 2nd Rd, Wen Hwa Tsuen, Kwei Shan Hsiang, Taoyuan
Hsien 333, Taiwan, R.O.C.



This report is for your exclusive use. Any copying or replication of this report to or for any other person or entity, or use of our name or trademark, is permitted only with our prior written permission. This report sets forth our findings solely with respect to the test samples identified herein. The results set forth in this report are not indicative or representative of the quality or characteristics of the lot from which a test sample was taken or any similar or identical product unless specifically and expressly noted. Our report includes all of the tests requested by you and the results thereof based upon the information that you provided to us. You have 60 days from date of issuance of this report to notify us of any material error or omission caused by our negligence, provided, however, that such notice shall be in writing and shall specifically address the issue you wish to raise. A failure to raise such issue within the prescribed time shall constitute your unqualified acceptance of the completeness of this report, the tests conducted and the correctness of the report contents. Unless specific mention, the uncertainty of measurement has been explicitly taken into account to declare the compliance or non-compliance to the specification. The report must not be used by the client to claim product certification, approval, or endorsement by TAF or any government agency

Table of Contents

Release Control Record	3
1 Certificate of Conformity	4
2 Summary of Test Results	5
2.1 Measurement Uncertainty	5
2.2 Test Site and Instruments	6
3 General Information	7
3.1 General Description of EUT	7
3.2 Configuration of System under Test	9
3.2.1 Description of Support Units	9
3.3 Test Mode Applicability and Tested Channel Detail	10
3.4 EUT Operating Conditions	12
3.5 General Description of Applied Standards	12
4 Test Types and Results	13
4.1 Output Power Measurement	13
4.1.1 Limits of Output Power Measurement	13
4.1.2 Test Procedures	13
4.1.3 Test Setup	14
4.1.4 Test Results	15
4.2 Frequency Stability Measurement	18
4.2.1 Limits of Frequency Stability Measurement	18
4.2.2 Test Procedure	18
4.2.3 Test Setup	18
4.2.4 Test Results	19
4.3 Occupied Bandwidth Measurement	23
4.3.1 Limits of Occupied Bandwidth Measurement	23
4.3.2 Test Procedure	23
4.3.3 Test Setup	23
4.3.4 Test Result	24
4.4 Band Edge Measurement	31
4.4.1 Limits of Band Edge Measurement	32
4.4.2 Test Setup	32
4.4.3 Test Procedures	32
4.4.4 Test Results	33
4.5 Peak to Average Ratio	39
4.5.1 Limits of Peak to Average Ratio Measurement	49
4.5.2 Test Setup	49
4.5.3 Test Procedures	49
4.5.4 Test Results	50
4.6 Conducted Spurious Emissions	56
4.6.1 Limits of Conducted Spurious Emissions Measurement	58
4.6.2 Test Setup	58
4.6.3 Test Procedure	58
4.6.4 Test Results	59
4.7 Radiated Emission Measurement	75
4.7.1 Limits of Radiated Emission Measurement	75
4.7.2 Test Procedure	75
4.7.3 Deviation from Test Standard	75
4.7.4 Test Setup	75
4.7.5 Test Results	76
5 Pictures of Test Arrangements	100
Appendix – Information on the Testing Laboratories	101

Release Control Record

Issue No.	Description	Date Issued
RF161222C05	Original Release	Jan. 26, 2017

1 Certificate of Conformity

Product: Nokia FW2H LTE module

Brand: Nokia

Test Model: FW2HBDPM01

Sample Status: ENGINEERING SAMPLE

Applicant: Nokia Solutions and Networks

Test Date: Jan. 11, 2017 ~ Jan. 21, 2017

Standards: FCC Part 27, Subpart C, M

The above equipment has been tested by **Bureau Veritas Consumer Products Services (H.K.) Ltd., Taoyuan Branch**, and found compliance with the requirement of the above standards. The test record, data evaluation & Equipment Under Test (EUT) configurations represented herein are true and accurate accounts of the measurements of the sample's EMC characteristics under the conditions specified in this report.

Prepared by :



Date:

Jan. 26, 2017

Gina Liu / Specialist

Approved by :

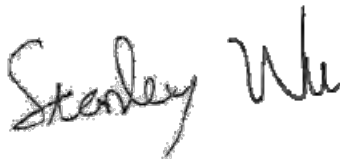

Date:

Jan. 26, 2017

Stanley Wu / Assistant Manager

2 Summary of Test Results

Applied Standard: FCC Part 27 & Part 2			
FCC Clause	Test Item	Result	Remarks
2.1046 27.50(h)	Equivalent Isotropic Radiated Power	Pass	Meet the requirement of limit.
2.1055 27.54	Frequency Stability	Pass	Meet the requirement of limit.
2.1049	Occupied Bandwidth	Pass	Meet the requirement of limit.
--	Peak to Average Ratio	Pass	Meet the requirement of limit.
2.1051 27.53(m)	Band Edge Measurements	Pass	Meet the requirement of limit.
2.1051 27.53(m)	Conducted Spurious Emissions	Pass	Meet the requirement of limit.
2.1053 27.53(m)	Radiated Spurious Emissions	Pass	Meet the requirement of limit. Minimum passing margin is -4.43 dB at 7779.00 MHz.

2.1 Measurement Uncertainty

Where relevant, the following measurement uncertainty levels have been estimated for tests performed on the EUT as specified in CISPR 16-4-2:

Measurement	Frequency	Expanded Uncertainty (k=2) (\pm)
Conducted Emissions at mains ports	150 kHz ~ 30 MHz	2.44 dB
Radiated Emissions up to 1 GHz	30 MHz ~ 200 MHz	2.93 dB
	200 MHz ~ 1000 MHz	2.95 dB
Radiated Emissions above 1 GHz	1 GHz ~ 18 GHz	2.26 dB
	18 GHz ~ 40 GHz	1.94 dB

2.2 Test Site and Instruments

Description & Manufacturer	Model No.	Serial No.	Date of Calibration	Due Date of Calibration
Test Receiver Agilent	N9038A	MY52260177	Jun. 21, 2016	Jun. 20, 2017
Spectrum Analyzer Agilent	N9010A	MY52220314	Dec. 16, 2016	Dec. 15, 2017
Spectrum Analyzer ROHDE & SCHWARZ	FSU43	101261	Dec. 13, 2016	Dec. 12, 2017
BILOG Antenna SCHWARZBECK	VULB9168	9168-472	Dec. 26, 2016	Dec. 27, 2017
HORN Antenna SCHWARZBECK	BBHA 9120 D	9120D-969	Dec. 12, 2016	Dec. 13, 2017
Double Ridge Guide Horn Antenna EMCO	3115	5619	Dec. 26, 2016	Dec. 27, 2017
BILOG Antenna SCHWARZBECK	VULB 9168	9168-153	Dec. 12, 2016	Dec. 13, 2017
HORN Antenna SCHWARZBECK	BBHA 9170	9170-480	Dec. 14, 2016	Dec. 13, 2017
Fixed Attenuator Mini-Circuits	BW-N10W5+	NA	Jul. 08, 2016	Jul. 07, 2017
MXG Vector signal generator Agilent	N5182B	MY53050430	Oct. 19, 2016	Oct. 18, 2017
Preamplifier EMCI	EMC 012645	980115	Oct. 21, 2016	Oct. 20, 2017
Preamplifier EMCI	EMC 184045	980116	Oct. 21, 2016	Oct. 20, 2017
Preamplifier EMCI	EMC 330H	980112	Oct. 21, 2016	Oct. 20, 2017
Power Meter Anritsu	ML2495A	1232002	Sep. 08, 2016	Sep. 07, 2017
Power Sensor Anritsu	MA2411B	1207325	Sep. 08, 2016	Sep. 07, 2017
RF signal cable HUBER+SUHNNER	SUCOFLEX 104	309219/4 2950114	Oct. 21, 2016	Oct. 20, 2017
RF signal cable HUBER+SUHNNER	SUCOFLEX 104	250130/4	Oct. 21, 2016	Oct. 20, 2017
RF Coaxial Cable Worken	8D-FB	Cable-Ch10-01	Oct. 21, 2016	Oct. 20, 2017
Software BV ADT	E3 6.120103	NA	NA	NA
Antenna Tower MF	MFA-440H	NA	NA	NA
Turn Table MF	MFT-201SS	NA	NA	NA
Antenna Tower & Turn Table Controller MF	MF-7802	NA	NA	NA
Temperature & Humidity Chamber Giant Force	GTH-120-40-CP-AR	MAA1306-019	Sep. 02, 2016	Sep. 01, 2017
DC Power Supply	33010D	807748	Oct. 25, 2016	Oct. 24, 2017

- Note: 1. The calibration interval of the above test instruments is 12 months and the calibrations are traceable to NML/ROC and NIST/USA.
2. The test was performed in HwaYa Chamber 10.
3. The horn antenna and preamplifier (model: EMC 184045) are used only for the measurement of emission frequency above 1 GHz if tested.
4. The FCC Site Registration No. is 690701.
5. The IC Site Registration No. is IC7450F-10.

3 General Information

3.1 General Description of EUT

Product	Nokia FW2H LTE module	
Brand	Nokia	
Test Model	FW2HBDPM01	
Status of EUT	ENGINEERING SAMPLE	
Power Supply Rating	12 Vdc from AC power adapter for host equipment 5.0 Vdc from host equipment for this modular	
Modulation Type	QPSK, 16QAM, 64QAM	
Frequency Range	LTE Band 41 (Channel Bandwidth: 10 MHz)	2501.0 ~ 2685.0 MHz
	LTE Band 41 (Channel Bandwidth: 15 MHz)	2503.5 ~ 2682.5 MHz
	LTE Band 41 (Channel Bandwidth: 20 MHz)	2506.0 ~ 2680.0 MHz
	LTE Band 41 (Channel Bandwidth: 20+20 MHz)	2516.0 ~ 2670.0 MHz
Number of Channel	LTE Band 41 (Channel Bandwidth: 10 MHz)	1841
	LTE Band 41 (Channel Bandwidth: 15 MHz)	1791
	LTE Band 41 (Channel Bandwidth: 20 MHz)	1741
	LTE Band 41 (Channel Bandwidth: 20+20 MHz)	1541
Max. EIRP Power	LTE Band 41 (Channel Bandwidth: 10 MHz)	641.21 mW (QPSK)
	LTE Band 41 (Channel Bandwidth: 15 MHz)	683.91 mW (QPSK)
	LTE Band 41 (Channel Bandwidth: 20 MHz)	767.36 mW (QPSK)
	LTE Band 41 (Channel Bandwidth: 20+20 MHz)	903.65 mW (QPSK)
Emission Designator	LTE Band 41 (Channel Bandwidth: 10 MHz)	QPSK: 8M99G7D
		16QAM: 8M99W7D
		64QAM: 8M99W7D
	LTE Band 41 (Channel Bandwidth: 15 MHz)	QPSK: 13M5G7D
		16QAM: 13M5W7D
		64QAM: 13M5W7D
	LTE Band 41 (Channel Bandwidth: 20 MHz)	QPSK: 18M0G7D
		16QAM: 18M0W7D
		64QAM: 18M0W7D
	LTE Band 41 (Channel Bandwidth: 20+20 MHz)	QPSK: 38M1G7D
		16QAM: 38M1W7D
		64QAM: 38M1W7D
Antenna Type	Refer to Note as below	
Antenna Connector	Refer to Note as below	
Accessory Device	N/A	
Data Cable Supplied	N/A	
S/N	Sample A: EB1643A0061	
	Sample B: EB1643A0042	

Note:

1. There is LTE technology used for the EUT, which supports 2496~2690MHz frequency band.
2. The EUT incorporates a MIMO function for LTE mode.

Channel Bandwidth	Modulation	TX & RX configuration	
10MHz	QPSK, 16QAM, 64QAM	2TX	2RX
15MHz	QPSK, 16QAM, 64QAM	2TX	2RX
20MHz	QPSK, 16QAM, 64QAM	2TX	2RX
20+20MHz	QPSK, 16QAM, 64QAM	2TX	2RX

3. The antennas provided to the EUT, please refer to the following table:

Antenna Spec.						
Sample	Antenna No	Brand	Model	Antenna Type	Gain (dBi)	Frequency (MHz)
A	Antenna #1	Galtronics	FW2HBDPM01	Slot Antenna	5.10	2496~2690
	Antenna #3				3.73	2496~2690
B	Antenna #2				2.61	2496~2690
	Antenna #4				4.12	2496~2690

Cable Spec.				
Brand	Model	Connector Type	Cable Loss (dB)	Cable Length (mm)
N/A	N/A	Rihg angle MMCX Plug	Peak gain included	287

4. The above EUT information is declared by manufacturer and for more detailed features description, please refer to the manufacturer's specifications or user's manual.

3.2 Configuration of System under Test

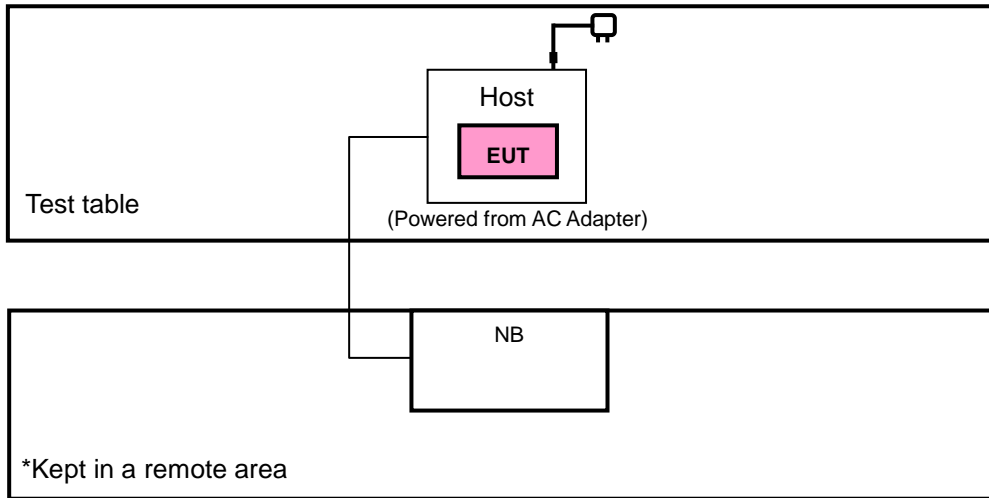

3.2.1 Description of Support Units

The EUT has been tested as an independent unit together with other necessary accessories or support units. The following support units or accessories were used to form a representative test configuration during the tests.

No.	Product	Brand	Model No.	Serial No.	FCC ID
1.	AC Adapter	DVE	DSA-60PFE-12 1 120500	N/A	N/A
2.	Notebook	N/A	N/A	N/A	N/A
3.	Host	Nokia	FW2HHWD	N/A	N/A

No.	Signal Cable Description Of The Above Support Units
1.	1.8m shielded cable with 1 core
2.	N/A
3.	N/A

Note:

1. All power cords of the above support units are non-shielded (1.8m).
2. Item 2 acted as communication partner to transfer data.
3. Item 3 was provided by client.

3.3 Test Mode Applicability and Tested Channel Detail

Pre-Scan has been conducted to determine the worst-case mode from all possible combinations between available modulations, data rates, XYZ axis, and antenna ports.

The worst case was found when positioned as the table below. Following channel(s) was (were) selected for the final test as listed below:

Band	Sample	EIRP	Radiated Emission
LTE Band 41	A	Z-plane	X-axis
	B		Z-axis

LTE Band 41

Test Item	Available Channel	Tested Channel	Channel Bandwidth	Modulation
Output Power	39700 to 41540	39700, 40620, 41540	10 MHz	QPSK
	39725 to 41515	39725, 40620, 41515	15 MHz	QPSK
	39750 to 41490	39750, 40620, 41490	20 MHz	QPSK
	39850 to 41390	39850, 40620, 41390	20+20 MHz	QPSK
Frequency Stability	39700 to 41540	39700, 41540	10 MHz	QPSK
	39725 to 41515	39725, 41515	15 MHz	QPSK
	39750 to 41490	39750, 41490	20 MHz	QPSK
	39850 to 41390	39850, 41390	20+20 MHz	QPSK
Occupied Bandwidth	39700 to 41540	39700, 40620, 41540	10 MHz	QPSK, 16QAM, 64QAM
	39725 to 41515	39725, 40620, 41515	15 MHz	QPSK, 16QAM, 64QAM
	39750 to 41490	39750, 40620, 41490	20 MHz	QPSK, 16QAM, 64QAM
	39850 to 41390	39850, 40620, 41390	20+20 MHz	QPSK, 16QAM, 64QAM
Peak to Average Ratio	39700 to 41540	39700, 40620, 41540	10 MHz	QPSK, 16QAM, 64QAM
	39725 to 41515	39725, 40620, 41515	15 MHz	QPSK, 16QAM, 64QAM
	39750 to 41490	39750, 40620, 41490	20 MHz	QPSK, 16QAM, 64QAM
	39850 to 41390	39850, 40620, 41390	20+20 MHz	QPSK, 16QAM, 64QAM
Band Edge	39700 to 41540	39700, 41540	10 MHz	QPSK
	39725 to 41515	39725, 41515	15 MHz	QPSK
	39750 to 41490	39750, 41490	20 MHz	QPSK
	39850 to 41390	39850, 41390	20+20 MHz	QPSK
Conducted Emission	39700 to 41540	39700, 40620, 41540	10 MHz	QPSK
	39725 to 41515	39725, 40620, 41515	15 MHz	QPSK
	39750 to 41490	39750, 40620, 41490	20 MHz	QPSK
	39850 to 41390	39850, 40620, 41390	20+20 MHz	QPSK
Radiated Emission	39700 to 41540	39700, 40620, 41540	10 MHz	QPSK
	39725 to 41515	39725, 40620, 41515	15 MHz	QPSK
	39750 to 41490	39750, 40620, 41490	20 MHz	QPSK
	39850 to 41390	39850, 40620, 41390	20+20 MHz	QPSK

Note:

- All supported modulation types were evaluated. The worst case emission of QPSK was selected. Therefore, the EIRP power, Frequency Stability, Band Edge, Conducted Emission and Radiated Emission were presented under QPSK mode only.
- For Radiated Emission, EUT has been pre-tested under following test samples, and sample A was the test for 10MHz / 15MHz / 20MHz, and sample B was test for 20+20MHz. For other test items, sample A is chosen for final test.

Sample	Description
A	S/N: EB1643A0061
B	S/N: EB1643A0042

Test Condition:

Test Item	Environmental Conditions	Input Power	Tested By
Output Power	25 deg. C, 65 % RH	120 Vac, 60 Hz	Gavin Wu
Frequency Stability	25 deg. C, 65 % RH	120 Vac, 60 Hz	Will Chen
Occupied Bandwidth	25 deg. C, 65 % RH	120 Vac, 60 Hz	Will Chen
Band Edge	25 deg. C, 65 % RH	120 Vac, 60 Hz	Will Chen
Peak to Average Ratio	25 deg. C, 65 % RH	120 Vac, 60 Hz	Will Chen
Conducuted Emission	25 deg. C, 65 % RH	120 Vac, 60 Hz	Will Chen
Radiated Emission	25 deg. C, 65 % RH	120 Vac, 60 Hz	Gavin Wu

3.4 EUT Operating Conditions

The test setup has been constructed as the normal use condition. Controlling software (provide by manufacturer) has been activated to set the EUT on specific status.

For the actual test configuration, please refer to the related item in this test report (photographs of the test configuration). (If an external ferrite core or similar means is used, describe attachment method etc.)

3.5 General Description of Applied Standards

The EUT is a RF Product. According to the specifications of the manufacturer, it must comply with the requirements of the following standards:

FCC 47 CFR Part 2

FCC 47 CFR Part 27

KDB 971168 D01 Power Meas License Digital Systems v02r02

ANSI/TIA/EIA-603-D 2010

Note: All test items have been performed and recorded as per the above standards.

4 Test Types and Results

4.1 Output Power Measurement

4.1.1 Limits of Output Power Measurement

The radiated peak output power shall be according to the specific rule Part 27.50(h)(2) that “User stations are limited to 2 watts” and 27.50(i) specific that “Peak transmit power must be measure over any interval of continuous transmission using instrumentation calibration in terms of rms-equivalent voltage.”

4.1.2 Test Procedures

EIRP Measurement:

- a. All measurements were done at low, middle and high operational frequency range. RBW and VBW is 10 MHz for LTE mode.
- b. Substitution method is used for E.I.R.P measurement. In the semi-anechoic chamber, EUT placed on the 0.8 m height of Turn Table, rotated the table around 360 degrees to search the maximum radiation power and receiver antenna shall be rotated vertical and horizontal polarization and moved height from 1 m to 4 m to find the maximum polar radiated power. The “Read Value” is the spectrum reading the maximum power value.
- c. The substitution horn antenna is substituted for EUT at the same position and signals generator export the CW signal to the substitution antenna via a tx cable. Rotated the Turn Table and moved receiving antenna to find the maximum radiation power. Adjust output power level of S.G to get a Value of spectrum reading equal to “Read Value“ of step b. Record the power level of S.G.
- d. $EIRP = \text{Output power level of S.G} - \text{TX cable loss} + \text{Antenna gain of substitution horn}.$

Conducted Power Measurement:

For 10 ~ 20MHz

A power sensor was used on the output port of the EUT. A power meter was used to read the response of the power sensor. Record the power level.

For 20+20 MHz

The transmitter output was connected to the spectrum analyzer through an attenuator. The power of the fundamental frequency was measured by spectrum analyzer with RBW=specified reference bandwidth (Often 1MHz).

4.1.3 Test Setup

EIRP / ERP Measurement:

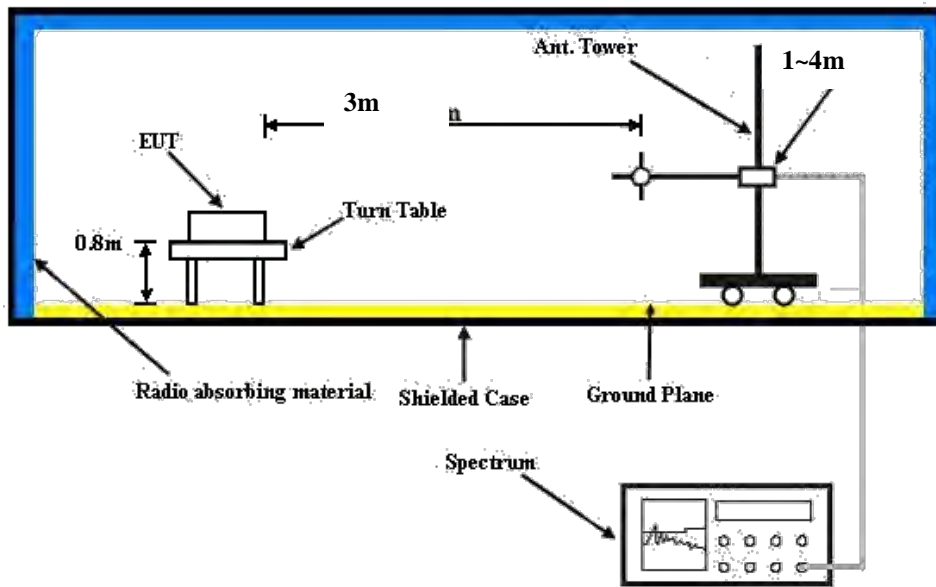

For the actual test configuration, please refer to the attached file (Test Setup Photo).

Conducted Power Measurement:

For 10MHz, 15MHz, 20MHz

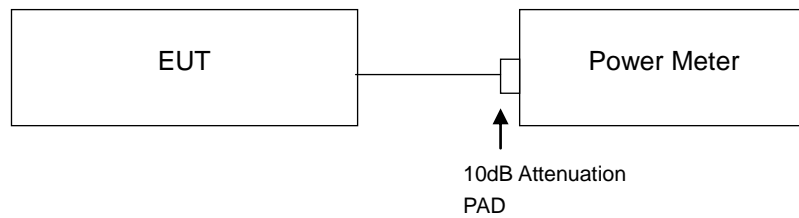

For 20+20MHz

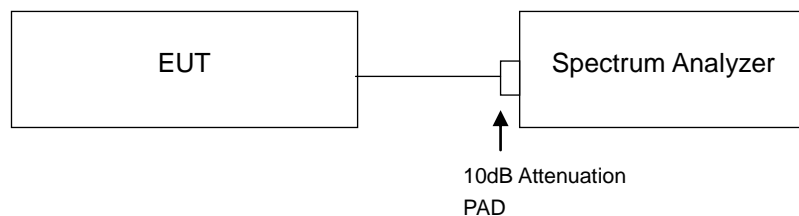

4.1.4 Test Results

Conducted Output Power (dBm)

Band / BW	Ant.	QPSK			16QAM			64QAM		
		Low Ch 39700	Mid Ch 40620	High Ch 41540	Low Ch 39700	Mid Ch 40620	High Ch 41540	Low Ch 39700	Mid Ch 40620	High Ch 41540
		2501.0 MHz	2593.0 MHz	2685.0 MHz	2501.0 MHz	2593.0 MHz	2685.0 MHz	2501.0 MHz	2593.0 MHz	2685.0 MHz
41 / 10M	Ant 0	24.27	24.32	24.45	24.23	24.30	24.42	24.25	24.27	24.39
	Ant 1	23.81	23.92	23.78	23.79	23.89	23.77	23.78	23.90	23.78
	Ant 0+1	27.06	27.13	27.14	27.03	27.11	27.12	27.03	27.10	27.11

Band / BW	Ant.	QPSK			16QAM			64QAM		
		Low Ch 39725	Mid Ch 40620	High Ch 41515	Low Ch 39725	Mid Ch 40620	High Ch 41515	Low Ch 39725	Mid Ch 40620	High Ch 41515
		2503.5 MHz	2593.0 MHz	2682.5 MHz	2503.5 MHz	2593.0 MHz	2682.5 MHz	2503.5 MHz	2593.0 MHz	2682.5 MHz
41 / 15M	Ant 0	24.34	24.33	24.48	24.32	24.30	24.45	24.31	24.29	24.44
	Ant 1	23.81	23.93	23.81	23.78	23.91	23.80	23.75	23.90	23.78
	Ant 0+1	27.09	27.14	27.17	27.07	27.12	27.15	27.05	27.11	27.13

Band / BW	Ant.	QPSK			16QAM			64QAM		
		Low Ch 39750	Mid Ch 40620	High Ch 41490	Low Ch 39750	Mid Ch 40620	High Ch 41490	Low Ch 39750	Mid Ch 40620	High Ch 41490
		2506.0 MHz	2593.0 MHz	2680.0 MHz	2506.0 MHz	2593.0 MHz	2680.0 MHz	2506.0 MHz	2593.0 MHz	2680.0 MHz
41 / 20M	Ant 0	24.35	24.36	24.49	24.33	24.32	24.45	24.32	24.29	24.44
	Ant 1	23.82	23.93	23.84	23.81	23.91	23.82	23.78	23.91	23.81
	Ant 0+1	27.10	27.16	27.19	27.09	27.13	27.16	27.07	27.11	27.15

Band / BW	Ant.	QPSK			16QAM			64QAM		
		Low Ch 39850	Mid Ch 40620	High Ch 41390	Low Ch 39850	Mid Ch 40620	High Ch 41390	Low Ch 39850	Mid Ch 40620	High Ch 41390
		2516.0 MHz	2593.0 MHz	2670.0 MHz	2516.0 MHz	2593.0 MHz	2670.0 MHz	2516.0 MHz	2593.0 MHz	2670.0 MHz
41 / 20M+20M	Ant 0	24.46	24.25	24.44	24.42	24.26	24.41	24.38	24.21	24.40
	Ant 1	24.10	24.17	23.91	24.05	24.11	23.88	24.04	24.14	23.85
	Ant 0+1	27.29	27.22	27.19	27.25	27.20	27.16	27.22	27.19	27.14

EIRP Power (dBm)

LTE Band 41							
Channel Bandwidth: 10 MHz / QPSK							
Plane	Channel	Frequency (MHz)	LVL (dBm)	Correction Factor (dB)	EIRP (dBm)	EIRP (mW)	Polarization (H/V)
Z	39700	2501.0	-18.84	38.98	20.14	103.28	H
	40620	2593.0	-17.12	38.17	21.05	127.35	
	41540	2685.0	-16.52	38.45	21.93	155.96	
	39700	2501.0	-11.87	39.04	27.17	521.19	V
	40620	2593.0	-10.61	38.68	28.07	641.21	
	41540	2685.0	-10.79	38.60	27.81	603.95	

LTE Band 41							
Channel Bandwidth: 15 MHz / QPSK							
Plane	Channel	Frequency (MHz)	LVL (dBm)	Correction Factor (dB)	EIRP (dBm)	EIRP (mW)	Polarization (H/V)
Z	39725	2503.5	-17.87	39.09	21.22	132.43	H
	40620	2593.0	-16.88	38.17	21.29	134.59	
	41515	2682.5	-16.38	38.52	22.14	163.68	
	39725	2503.5	-11.15	39.04	27.89	615.18	V
	40620	2593.0	-10.43	38.68	28.25	668.34	
	41515	2682.5	-10.31	38.66	28.35	683.91	

LTE Band 41							
Channel Bandwidth: 20 MHz / QPSK							
Plane	Channel	Frequency (MHz)	LVL (dBm)	Correction Factor (dB)	EIRP (dBm)	EIRP (mW)	Polarization (H/V)
Z	39750	2506.0	-17.52	39.26	21.74	149.28	H
	40620	2593.0	-16.62	38.17	21.55	142.89	
	41490	2680.0	-15.94	38.71	22.77	189.23	
	39750	2506.0	-11.11	39.33	28.22	663.74	V
	40620	2593.0	-9.83	38.68	28.85	767.36	
	41490	2680.0	-10.15	38.76	28.61	726.11	

LTE Band 41							
Channel Bandwidth: 20MHz+20MHz / QPSK							
Plane	Channel	Frequency (MHz)	LVL (dBm)	Correction Factor (dB)	EIRP (dBm)	EIRP (mW)	Polarization (H/V)
Z	39850	2516.0	-15.78	39.26	23.48	222.84	H
	40620	2593.0	-14.35	38.17	23.82	240.99	
	41390	2670.0	-15.32	38.71	23.39	218.27	
	39850	2516.0	-10.42	39.33	28.91	778.04	V
	40620	2593.0	-9.12	38.68	29.56	903.65	
	41390	2670.0	-9.33	38.76	29.43	877.00	

4.2 Frequency Stability Measurement

4.2.1 Limits of Frequency Stability Measurement

The frequency stability shall be sufficient to ensure that the fundamental emissions stay within the authorized bands of operation.

4.2.2 Test Procedure

- Device is placed at the oven room. The oven room could control the temperatures and humidity. Power warm up is at least 15 min and power applied should perform before recording frequency error.
- EUT is connected the external power supply to control the DC input power. The test voltage range is from minimum to maximum working voltage. Each step shall be record the frequency error rate.
- The temperature range step is 10 degrees in this test items. All temperature levels shall be hold the ± 0.5 °C during the measurement testing. The each temperature step shall be at least 0.5 hours, consider the EUT could be test under the stability condition.

NOTE: The frequency error was recorded frequency error from the communication simulator.

4.2.3 Test Setup

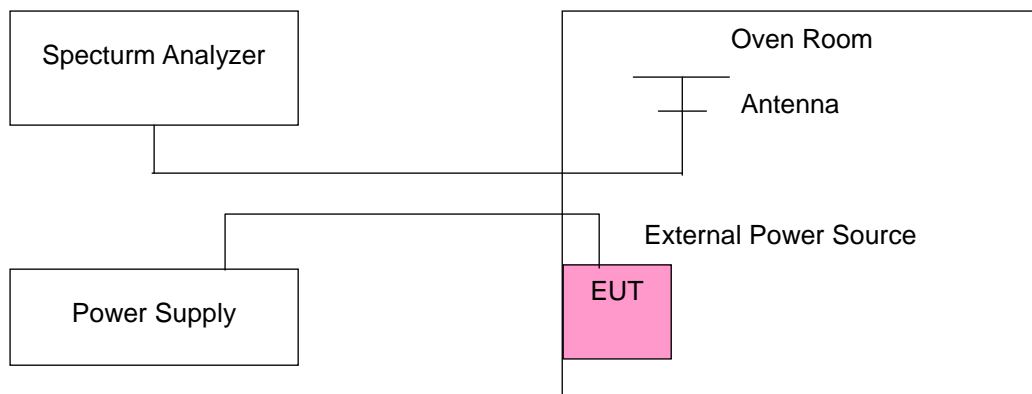

4.2.4 Test Results

Frequency Error vs. Voltage

Voltage (Volts)	LTE Band 41				Limit (ppm)
	Channel Bandwidth: 10 MHz				
	Low Channel		High Channel		
	Frequency (MHz)	Frequency Error (ppm)	Frequency (MHz)	Frequency Error (ppm)	
12.0	2501.000003	0.001	2685.000003	0.001	2.5
10.2	2501.000002	0.001	2685.000002	0.001	2.5
13.8	2501.000001	0.000	2685.000003	0.001	2.5

Frequency Error vs. Temperature

Temp. (°C)	LTE Band 41				Limit (ppm)
	Channel Bandwidth: 10 MHz				
	Low Channel		High Channel		
	Frequency (MHz)	Frequency Error (ppm)	Frequency (MHz)	Frequency Error (ppm)	
-10	2501.000003	0.001	2685.000002	0.001	2.5
0	2501.000002	0.001	2685.000003	0.001	2.5
10	2501.000003	0.001	2685.000003	0.001	2.5
20	2500.999998	-0.001	2684.999999	0.000	2.5
30	2500.999999	-0.001	2684.999997	-0.001	2.5
40	2500.999998	-0.001	2684.999997	-0.001	2.5

Frequency Error vs. Voltage

Voltage (Volts)	LTE Band 41				Limit (ppm)
	Channel Bandwidth: 15 MHz				
	Low Channel		High Channel		
	Frequency (MHz)	Frequency Error (ppm)	Frequency (MHz)	Frequency Error (ppm)	
12.0	2503.500003	0.001	2682.500002	0.001	2.5
10.2	2503.500001	0.000	2682.500004	0.001	2.5
13.8	2503.500002	0.001	2682.500002	0.001	2.5

Frequency Error vs. Temperature

Temp. (°C)	LTE Band 41				Limit (ppm)
	Channel Bandwidth: 15 MHz				
	Low Channel		High Channel		
	Frequency (MHz)	Frequency Error (ppm)	Frequency (MHz)	Frequency Error (ppm)	
-10	2503.500002	0.001	2682.500004	0.001	2.5
0	2503.500002	0.001	2682.500001	0.000	2.5
10	2503.500004	0.002	2682.500003	0.001	2.5
20	2503.499996	-0.002	2682.499999	0.000	2.5
30	2503.499998	-0.001	2682.499997	-0.001	2.5
40	2503.499999	0.000	2682.499997	-0.001	2.5

Frequency Error vs. Voltage

Voltage (Volts)	LTE Band 41				Limit (ppm)
	Channel Bandwidth: 20 MHz				
	Low Channel		High Channel		
	Frequency (MHz)	Frequency Error (ppm)	Frequency (MHz)	Frequency Error (ppm)	
12.0	2506.000002	0.001	2680.000004	0.001	2.5
10.2	2506.000003	0.001	2680.000004	0.001	2.5
13.8	2506.000001	0.000	2680.000003	0.001	2.5

Frequency Error vs. Temperature

Temp. (°C)	LTE Band 41				Limit (ppm)
	Channel Bandwidth: 20 MHz				
	Low Channel		High Channel		
	Frequency (MHz)	Frequency Error (ppm)	Frequency (MHz)	Frequency Error (ppm)	
-10	2506.000003	0.001	2680.000002	0.001	2.5
0	2506.000004	0.001	2680.000002	0.001	2.5
10	2506.000002	0.001	2680.000002	0.001	2.5
20	2505.999996	-0.002	2679.999998	-0.001	2.5
30	2505.999999	-0.001	2679.999997	-0.001	2.5
40	2505.999997	-0.001	2679.999997	-0.001	2.5

Frequency Error vs. Voltage

Voltage (Volts)	LTE Band 41				Limit (ppm)
	Channel Bandwidth: 20+20 MHz				
	Low Channel		High Channel		
	Frequency (MHz)	Frequency Error (ppm)	Frequency (MHz)	Frequency Error (ppm)	
12.0	2516.000004	0.001	2670.000004	0.001	2.5
10.2	2516.000001	0.001	2670.000004	0.001	2.5
13.8	2516.000003	0.001	2670.000002	0.001	2.5

Frequency Error vs. Temperature

Temp. (°C)	LTE Band 41				Limit (ppm)
	Channel Bandwidth: 20+20 MHz				
	Low Channel		High Channel		
	Frequency (MHz)	Frequency Error (ppm)	Frequency (MHz)	Frequency Error (ppm)	
-10	2516.000003	0.001	2670.000001	0.000	2.5
0	2516.000004	0.001	2670.000003	0.001	2.5
10	2516.000002	0.001	2670.000003	0.001	2.5
20	2515.999998	-0.001	2669.999998	-0.001	2.5
30	2515.999998	-0.001	2669.999997	-0.001	2.5
40	2515.999997	-0.001	2669.999998	-0.001	2.5

4.3 Occupied Bandwidth Measurement

4.3.1 Limits of Occupied Bandwidth Measurement

The width of a frequency band such that, below the lower and above the upper frequency limits, the mean powers emitted are each equal to a specified percentage 0.5 % of the total mean power of a given emission.

4.3.2 Test Procedure

- a. The transmitter output was connect to spectrum analyzer through attenuator.
- b. Use OBW measurement function of Spectrum analyzer to measure 99 % occupied bandwidth.

4.3.3 Test Setup

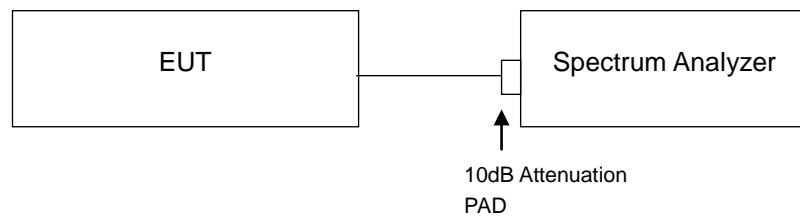

4.3.4 Test Result

Chain 0

LTE Band 41				
Channel Bandwidth: 10 MHz				
Channel	Frequency (MHz)	99 % Occupied Bandwidth (MHz)		
		QPSK	16QAM	64QAM
39700	2501.0	8.99	8.99	8.99
40620	2593.0	8.99	8.99	8.99
41540	2685.0	8.99	8.99	8.99

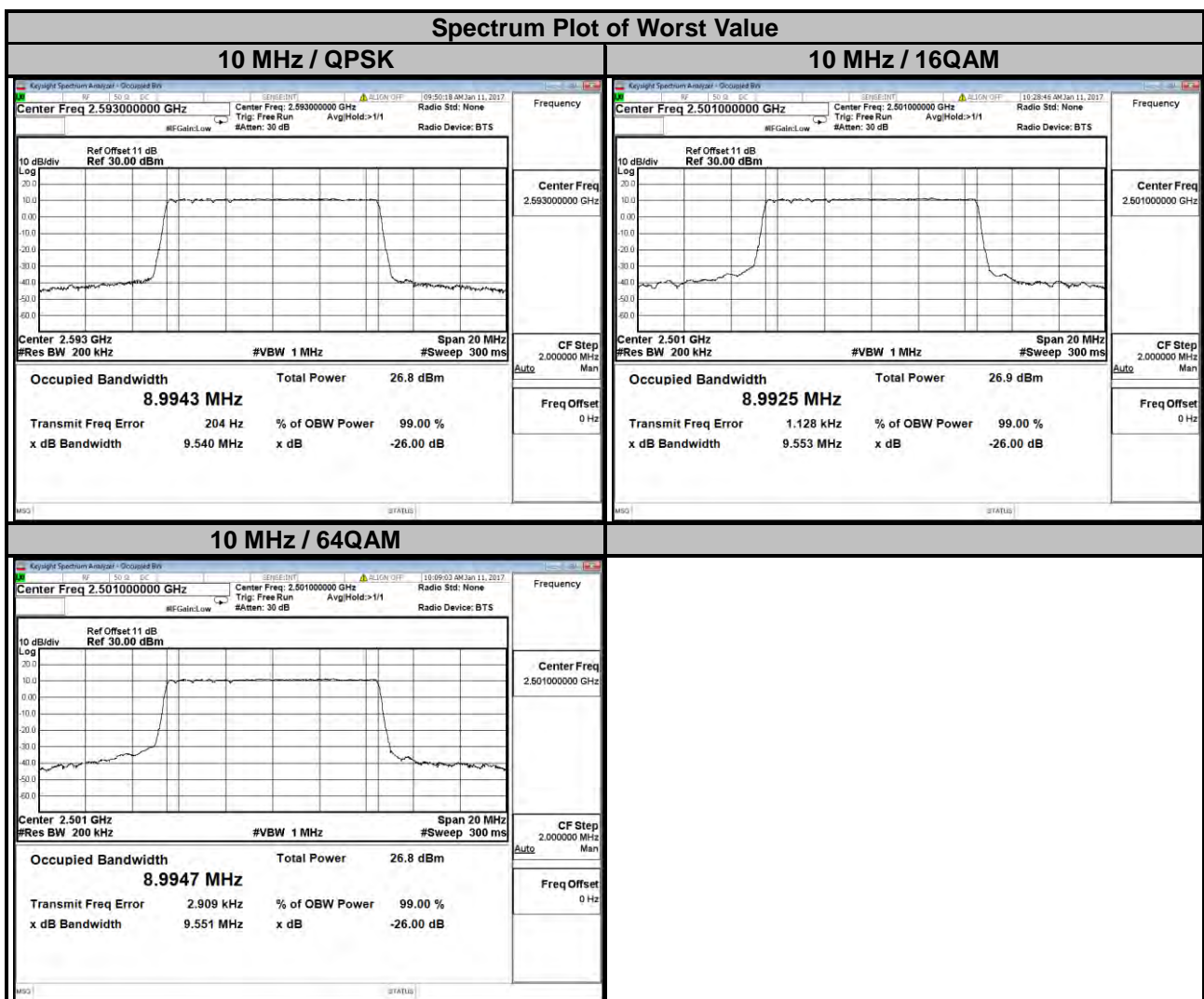

LTE Band 41

Channel Bandwidth: 15 MHz

Channel	Frequency (MHz)	99 % Occupied Bandwidth (MHz)		
		QPSK	16QAM	64QAM
39725	2503.5	13.49	13.49	13.49
40620	2593.0	13.49	13.49	13.49
41515	2682.5	13.49	13.49	13.49

Spectrum Plot of Worst Value

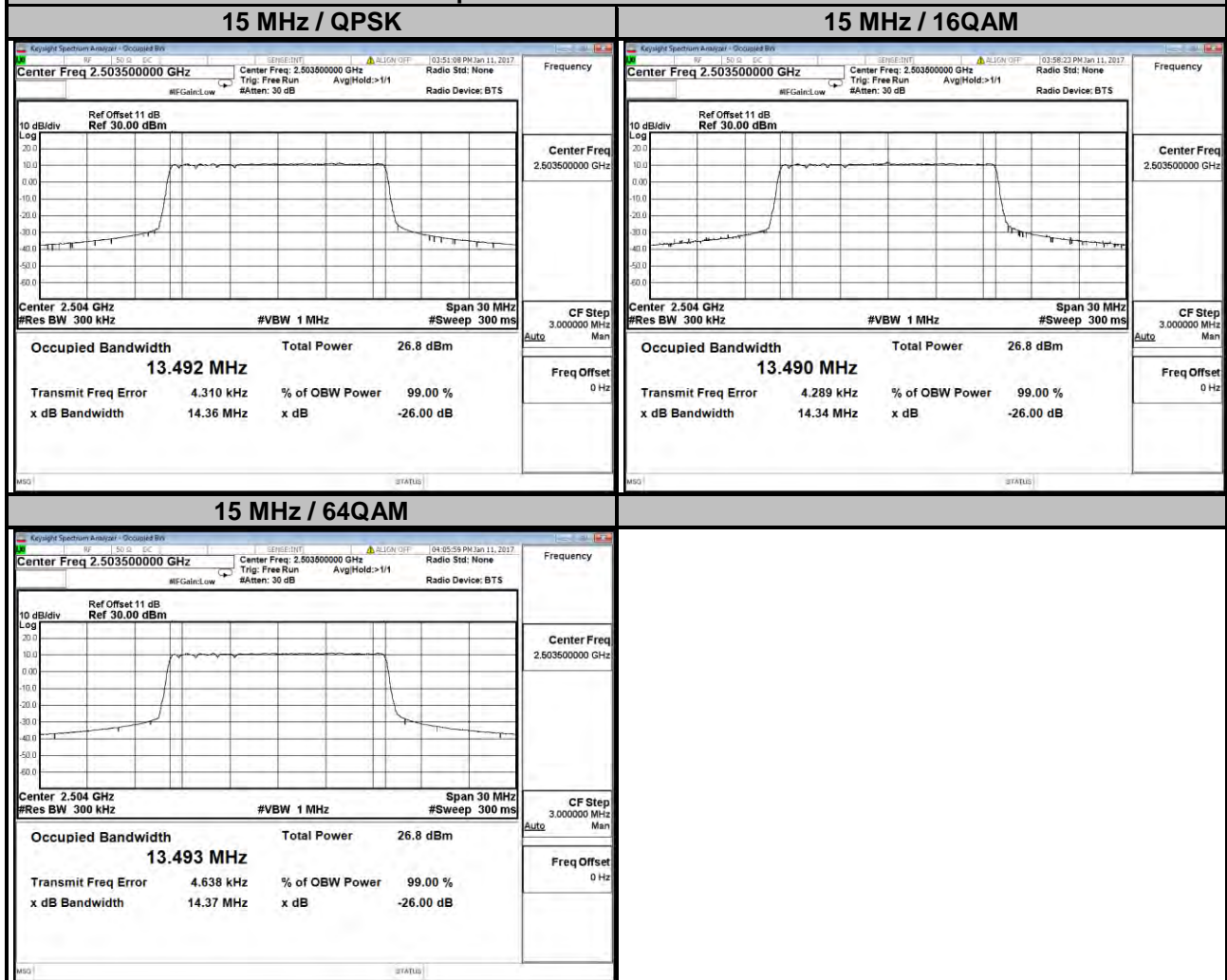

LTE Band 41

Channel Bandwidth: 20 MHz

Channel	Frequency (MHz)	99 % Occupied Bandwidth (MHz)		
		QPSK	16QAM	64QAM
39750	2506.0	17.99	17.99	17.99
40620	2593.0	17.99	17.99	17.99
41490	2680.0	17.99	17.99	17.99

Spectrum Plot of Worst Value

20 MHz / QPSK

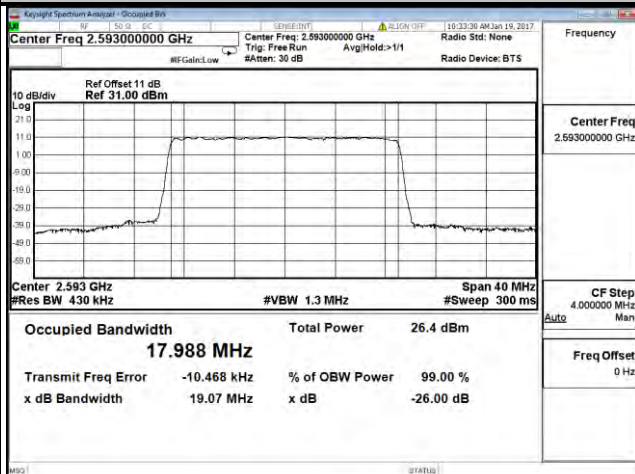

20 MHz / 16QAM

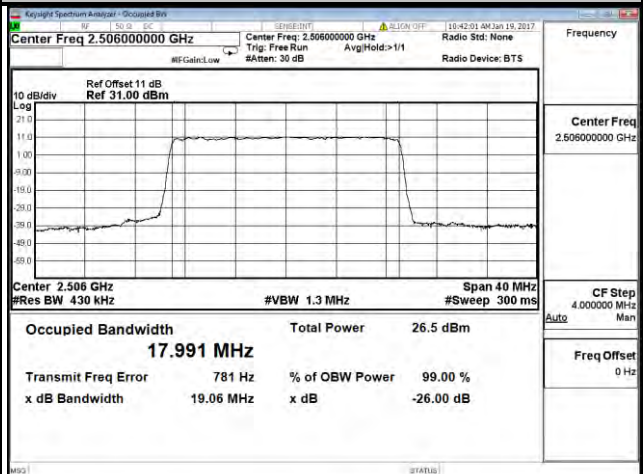

20 MHz / 64QAM

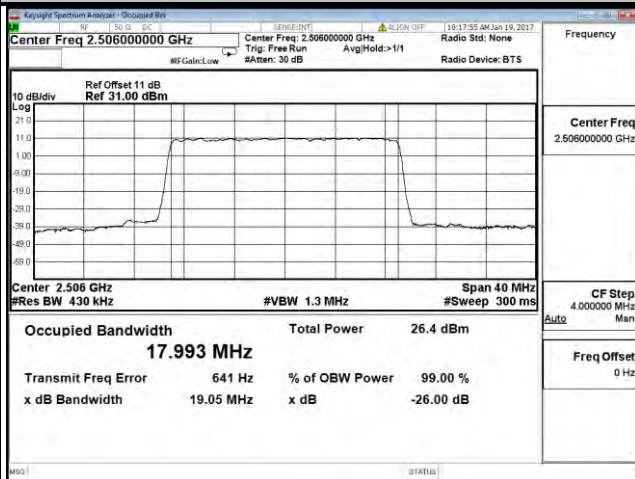

Chain 1

LTE Band 41				
Channel Bandwidth: 10 MHz				
Channel	Frequency (MHz)	99 % Occupied Bandwidth (MHz)		
		QPSK	16QAM	64QAM
39700	2501.0	8.99	8.99	8.99
40620	2593.0	8.99	8.99	8.99
41540	2685.0	8.99	8.99	8.99

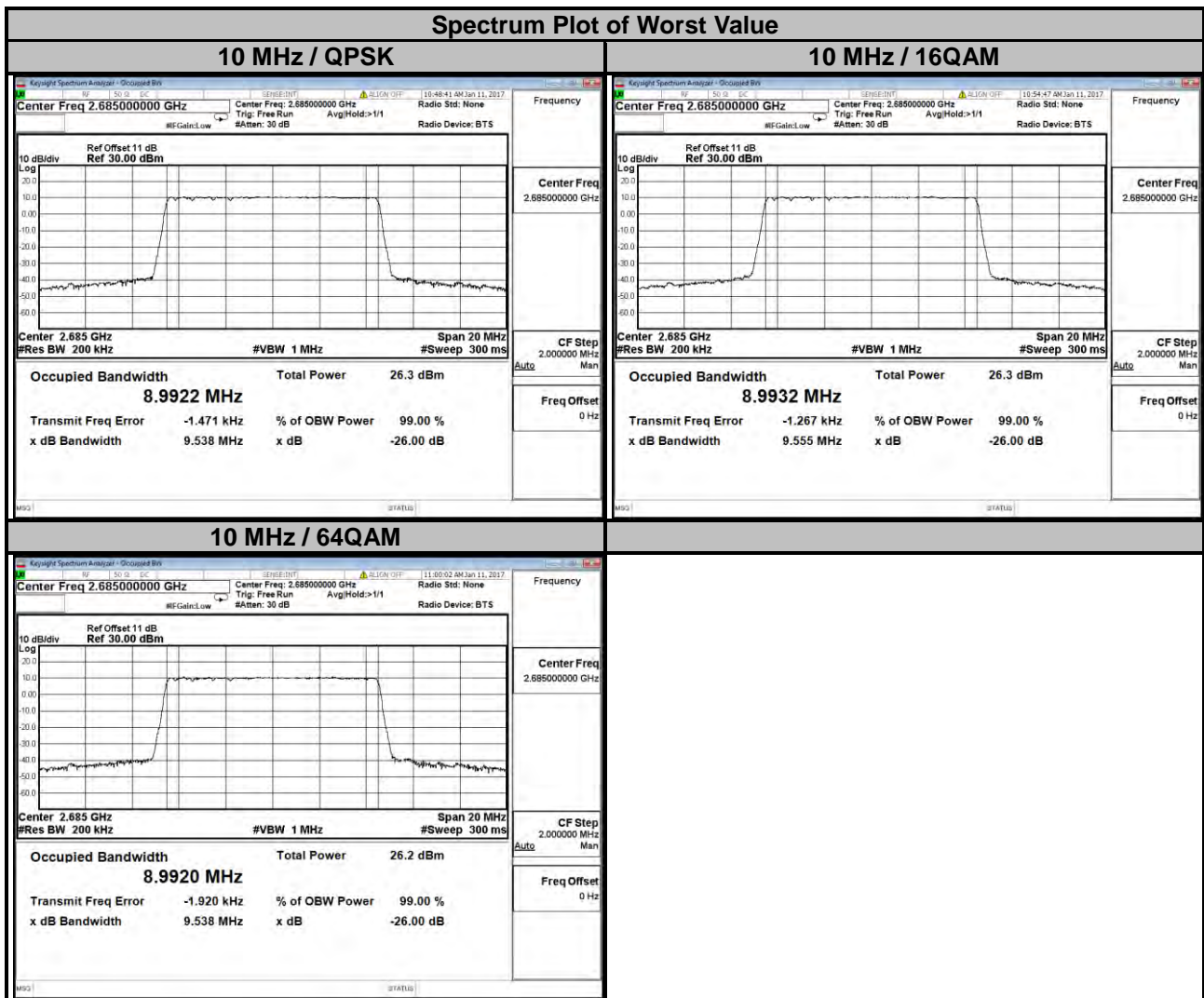

LTE Band 41

Channel Bandwidth: 15 MHz

Channel	Frequency (MHz)	99 % Occupied Bandwidth (MHz)		
		QPSK	16QAM	64QAM
39725	2503.5	13.49	13.49	13.49
40620	2593.0	13.49	13.49	13.49
41515	2682.5	13.49	13.49	13.49

Spectrum Plot of Worst Value

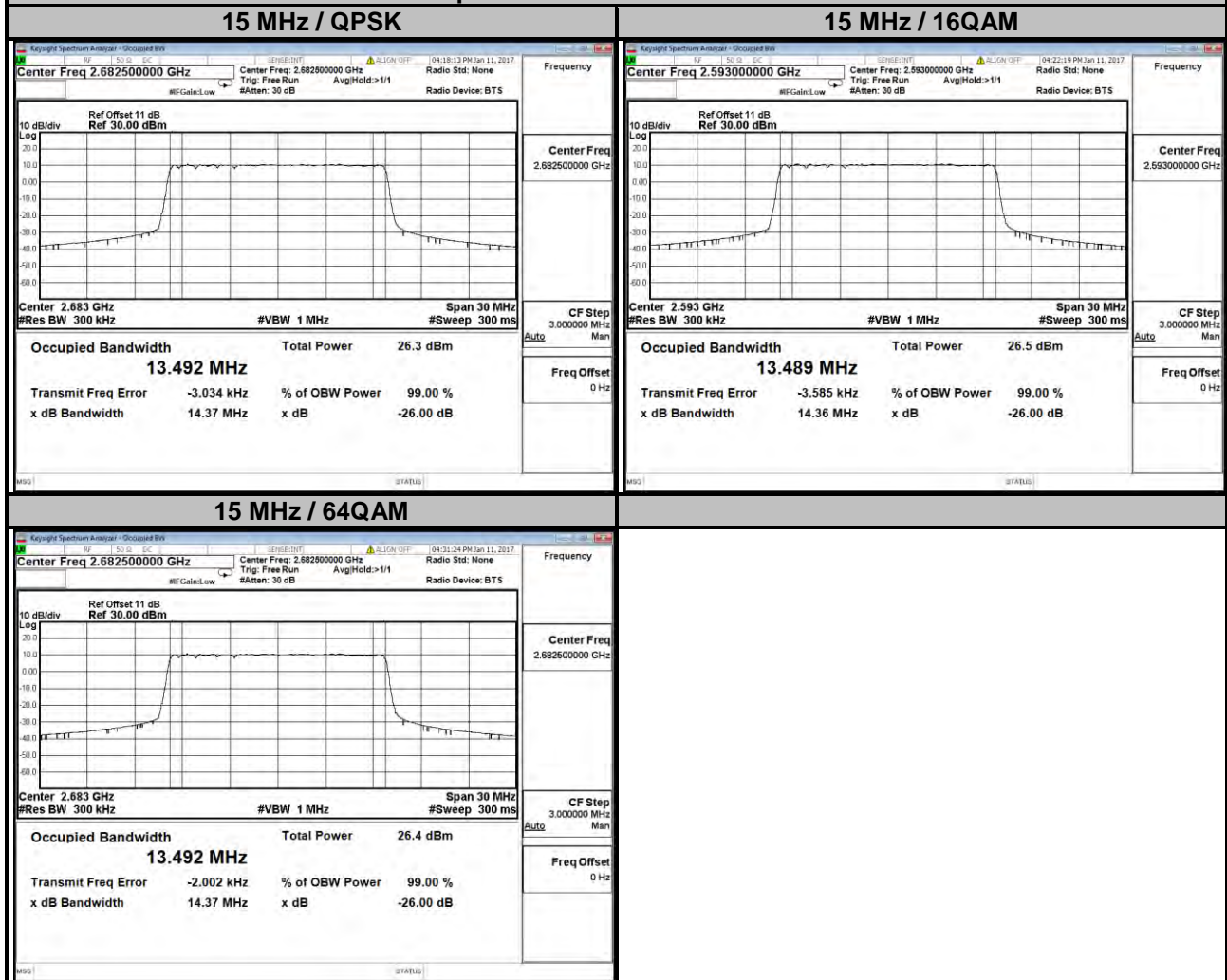

LTE Band 41

Channel Bandwidth: 20 MHz

Channel	Frequency (MHz)	99 % Occupied Bandwidth (MHz)		
		QPSK	16QAM	64QAM
39750	2506.0	17.99	17.99	17.99
40620	2593.0	17.99	17.99	17.99
41490	2680.0	17.99	17.99	17.99

Spectrum Plot of Worst Value

20 MHz / QPSK

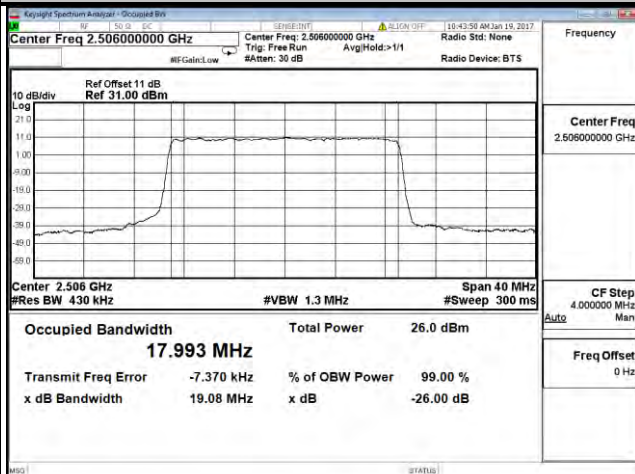

20 MHz / 16QAM

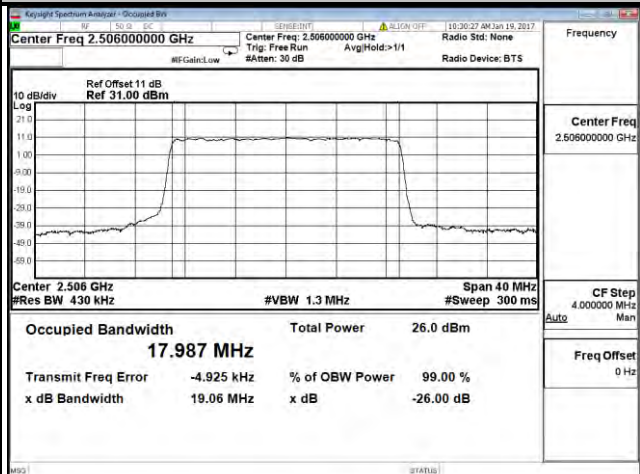

20 MHz / 64QAM

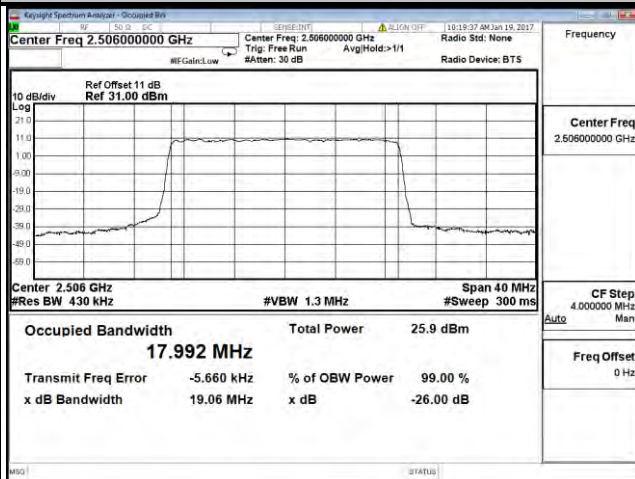

Chain 0

LTE Band 41				
Channel Bandwidth: 20+20 MHz				
Channel	Frequency (MHz)	99 % Occupied Bandwidth (MHz)		
		QPSK	16QAM	64QAM
39850	2516.0	38.08	38.08	38.08
40620	2593.0	38.07	38.06	38.06
41390	2670.0	38.06	38.07	38.06

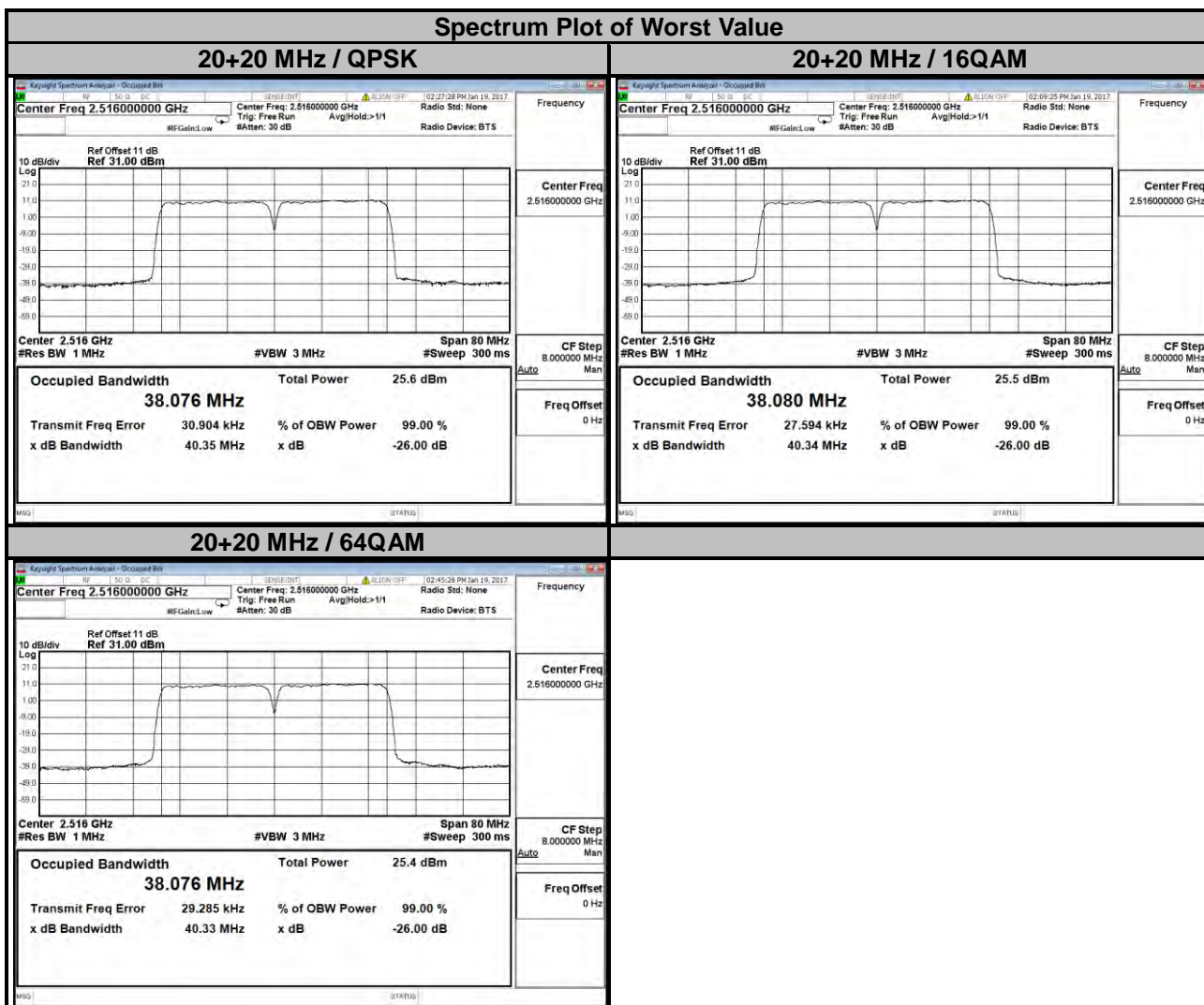

Chain 1

LTE Band 41				
Channel Bandwidth: 20+20 MHz				
Channel	Frequency (MHz)	99 % Occupied Bandwidth (MHz)		
		QPSK	16QAM	64QAM
39850	2516.0	38.09	38.09	38.08
40620	2593.0	38.06	38.06	38.06
41390	2670.0	38.05	38.06	38.06

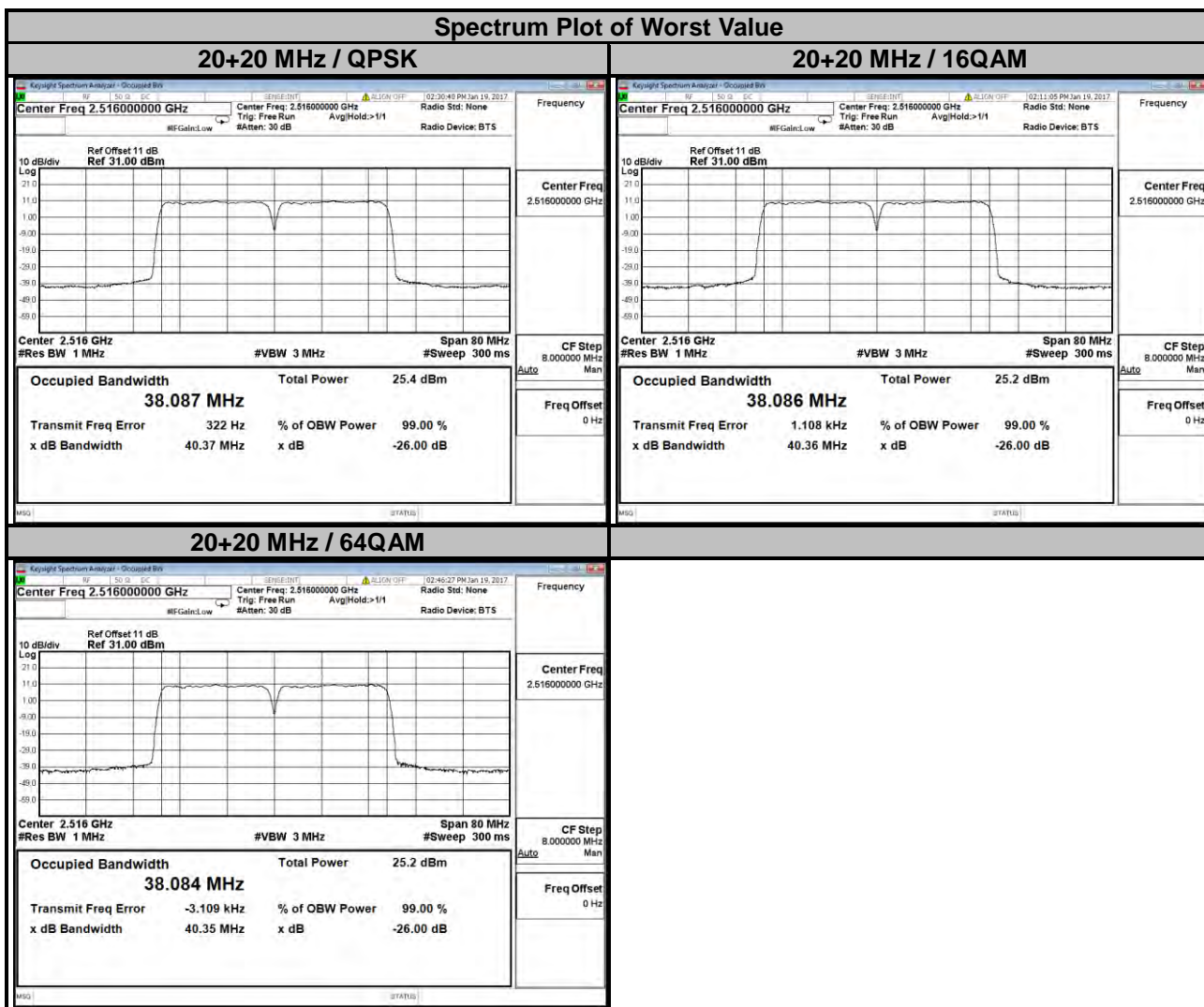

4.4 Band Edge Measurement

4.4.1 Limits of Band Edge Measurement

According to FCC 27.53(m)(4) specified that power of any emission outside of the channel edge must be attenuated below the transmitting power (P) by a factor shall be not less than $40 + 10 \log (P)$ dB on all frequencies between the channel edge and 5 megahertz from the channel edge, $43 + 10 \log (P)$ dB on all frequencies between 5 megahertz and X megahertz from the channel edge, and $55 + 10 \log (P)$ dB on all frequencies more than X megahertz from the channel edge, where X is the greater of 6 megahertz or the actual emission bandwidth. In addition, the attenuation factor shall not be less that $43 + 10 \log (P)$ dB on all frequencies between 2490.5 MHz and 2496 MHz and $55 + 10 \log (P)$ dB at or below 2490.5 MHz. In the 1 MHz bands immediately outside and adjacent to the frequency block a resolution bandwidth of at least two percent may be employed, except when the 1 megahertz band is 2495-2496 MHz, in which case a resolution bandwidth of at least one percent may be employed.

Note:

This device can be implemet MIMO function, so the limit of spurious emissions needs to be reduced by $10\log(\text{Numbers}_{\text{Ant}})$ according to FCC KDB 662911 D01 guidance.

{The limit is adjusted to $-13\text{dBm} - 10*\log(2) = -16.01\text{dBm}$.}

4.4.2 Test Setup

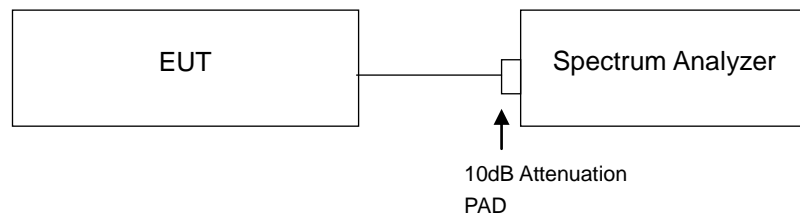

4.4.3 Test Procedures

- The EUT was set up for the maximum peak power with LTE link data modulation. The power was measured with Spectrum Analyzer. All measurements were done at 2 channels (low and high operational frequency range.).
- The center frequency of spectrum is the band edge frequency and span is 8 MHz. RB of the spectrum is 100 kHz (Channel bandwidth 5 MHz & 10 MHz).
- The center frequency of spectrum is the band edge frequency and span is 8 MHz. RB of the spectrum is 150 kHz (Channel bandwidth 15 MHz).
- The center frequency of spectrum is the band edge frequency and span is 8 MHz. RB of the spectrum is 200 kHz (Channel bandwidth 20 MHz).
- The center frequency of spectrum is the band edge frequency and span is 8 MHz. RB of the spectrum is 430 kHz (Channel bandwidth 20+20 MHz).
- Record the max trace plot into the test report.

4.4.4 Test Results

Chain 0

LTE Band 41				
Channel Bandwidth: 10 MHz / QPSK				
Frequency (MHz)	Measurement Value	Limit	Margin	Result
2496.00	-46.27	-16.01	-30.26	Pass
2690.02	-46.76	-16.01	-30.75	Pass

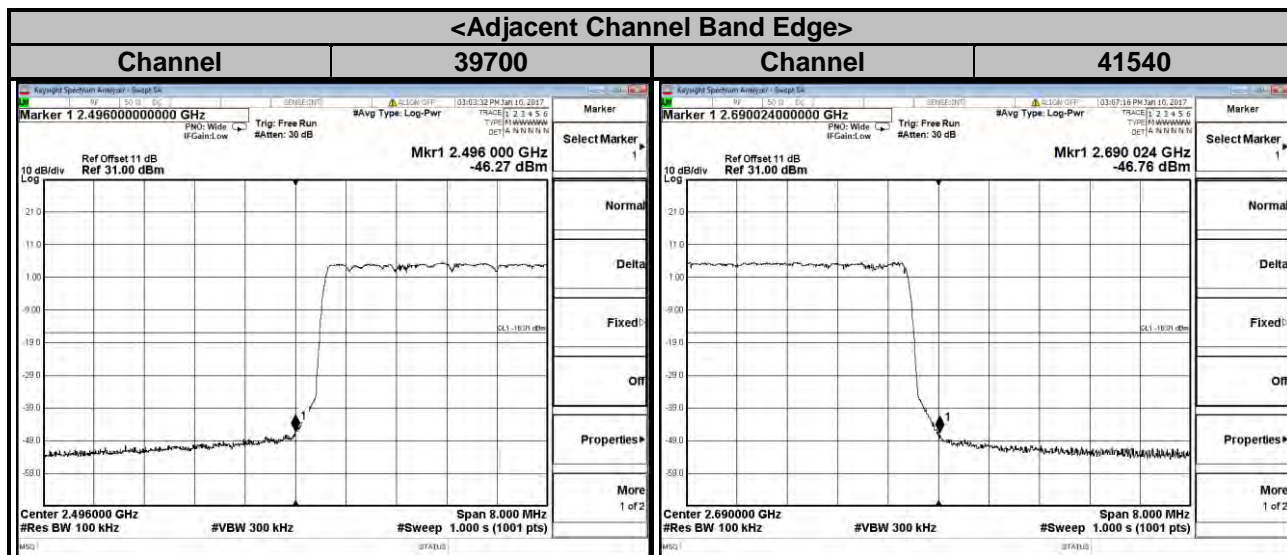

LTE Band 41				
Channel Bandwidth: 10 MHz / QPSK				
Low Channel 39700				
Frequency (MHz)	Measurement Value	Limit	Margin	Result
2489.69	-48.20	-25.00	-23.20	Pass
2496.00	-41.68	-13.00	-28.68	Pass
High Channel 41540				
Frequency (MHz)	Measurement Value	Limit	Margin	Result
2690.00	-38.56	-10.00	-28.56	Pass
2695.00	-47.15	-13.00	-34.15	Pass
2706.15	-52.78	-25.00	-27.78	Pass

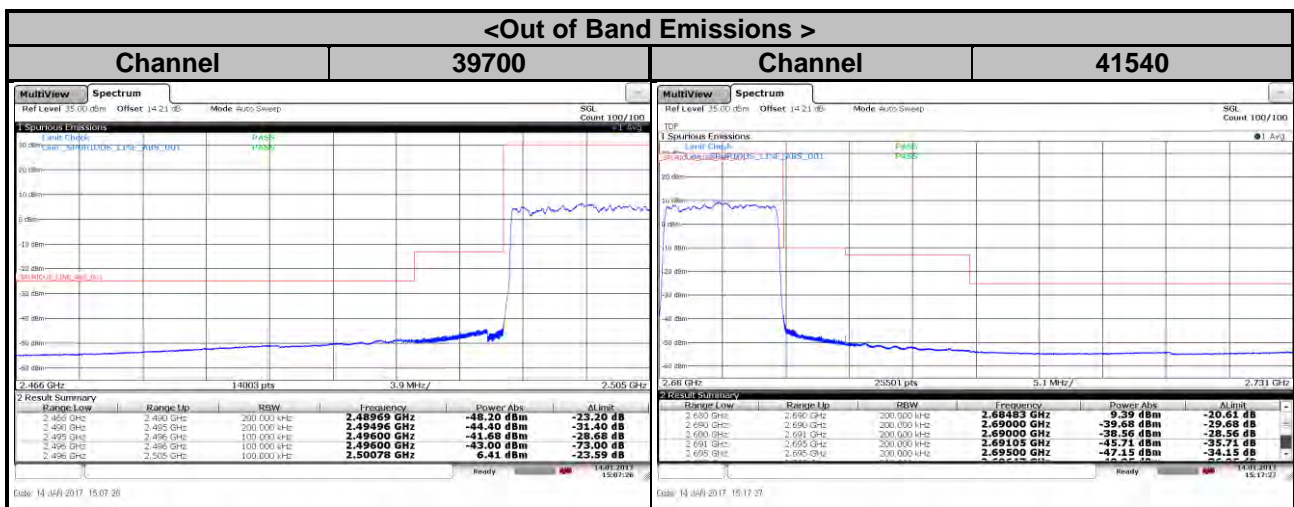

Note: Because the device support MIMO function need to calculate that include 10log (NumbersAnt)
 Setup Loss + cable loss = 11.2 ,
 NumbersAnt = 2 , 10log(2)= 3.01
 Total loss offset = 11.2+3.01=14.21

LTE Band 41				
Channel Bandwidth: 15 MHz / QPSK				
Frequency (MHz)	Measurement Value	Limit	Margin	Result
2495.99	-46.00	-16.01	-29.99	Pass
2690.01	-46.73	-16.01	-30.72	Pass

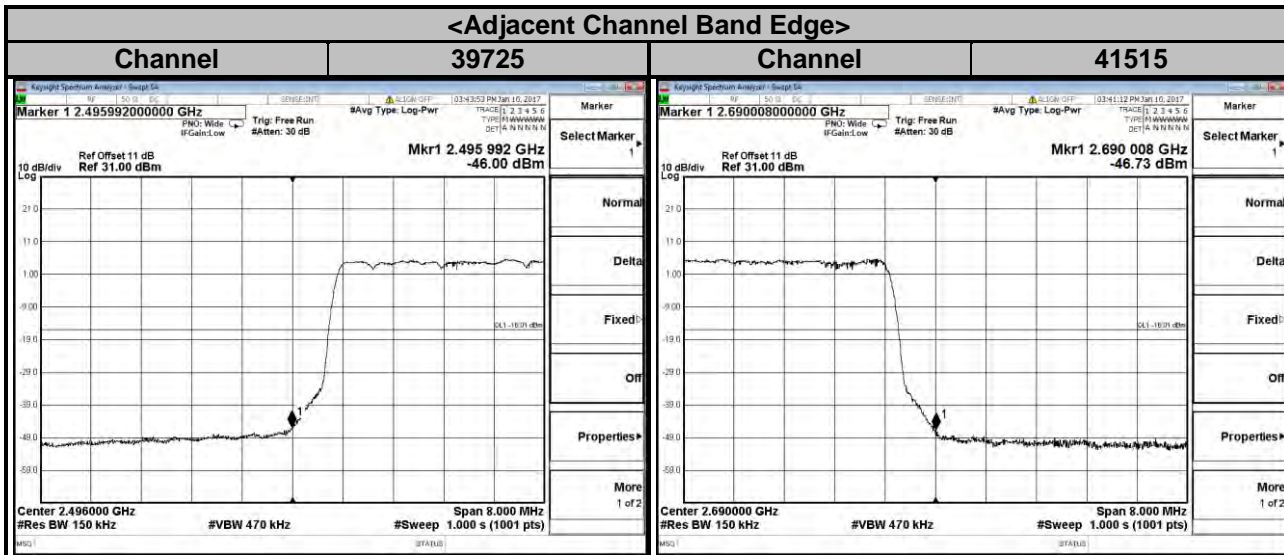

LTE Band 41

Channel Bandwidth: 15 MHz / QPSK

Low Channel 39725

Frequency (MHz)	Measurement Value	Limit	Margin	Result
2490.50	-46.16	-25.00	-21.16	Pass
2495.99	-39.43	-13.00	-26.43	Pass

High Channel 41515

Frequency (MHz)	Measurement Value	Limit	Margin	Result
2690.01	-39.60	-10.00	-29.60	Pass
2695.00	-44.29	-13.00	-31.29	Pass
2706.08	-50.87	-25.00	-25.87	Pass

<Out of Band Emissions >

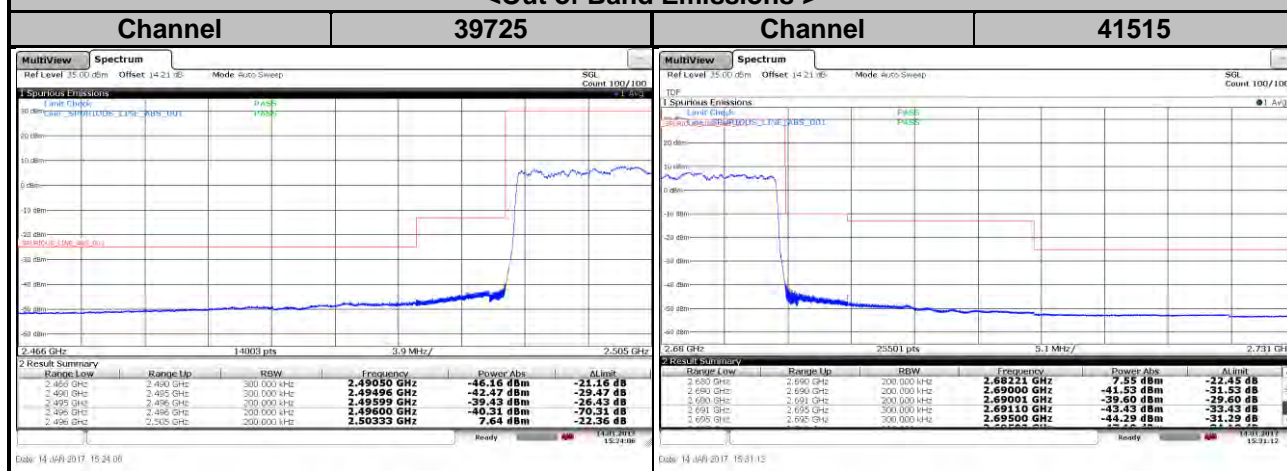

Note: Because the device support MIMO function need to calculate that include 10log (NumbersAnt)
 Setup Loss + cable loss = 11.2 ,
 NumbersAnt = 2 , 10log(2)= 3.01
 Total loss offset = 11.2+3.01=14.21

LTE Band 41				
Channel Bandwidth: 20 MHz / QPSK				
Frequency (MHz)	Measurement Value	Limit	Margin	Result
2495.98	-46.59	-16.01	-30.58	Pass
2690.03	-47.38	-16.01	-31.37	Pass

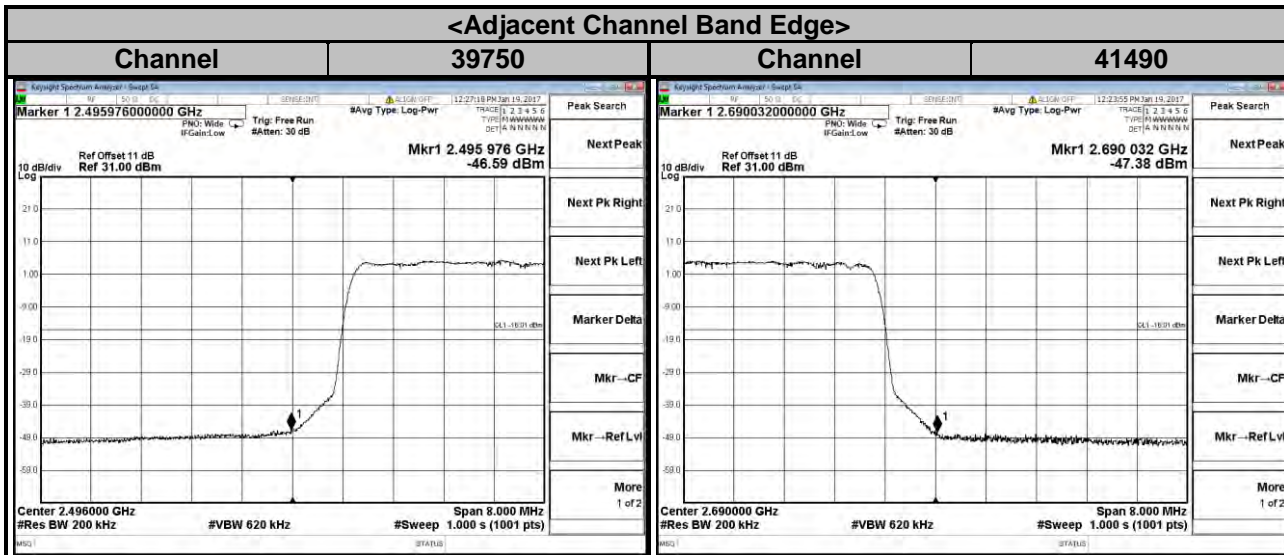

LTE Band 41

Channel Bandwidth: 20 MHz / QPSK

Low Channel 39750

Frequency (MHz)	Measurement Value	Limit	Margin	Result
2488.65	-45.30	-25.00	-20.30	Pass
2496.00	-40.67	-13.00	-27.67	Pass

High Channel 41490

Frequency (MHz)	Measurement Value	Limit	Margin	Result
2690.00	-42.43	-10.00	-32.43	Pass
2695.00	-42.04	-13.00	-29.04	Pass
2705.18	-49.98	-25.00	-24.98	Pass

<Out of Band Emissions >

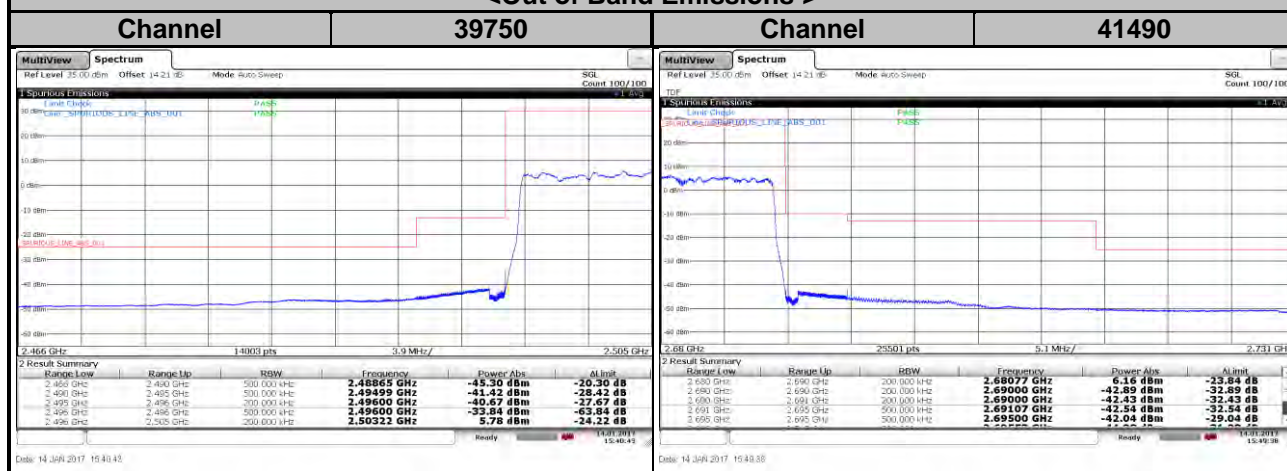

Note: Because the device support MIMO function need to calculate that include 10log (NumbersAnt)
 Setup Loss + cable loss = 11.2 ,
 NumbersAnt = 2 , 10log(2)= 3.01
 Total loss offset = 11.2+3.01=14.21

Chain 1

LTE Band 41				
Channel Bandwidth: 10 MHz / QPSK				
Frequency (MHz)	Measurement Value	Limit	Margin	Result
2495.99	-47.62	-16.01	-31.61	Pass
2690.00	-48.34	-16.01	-32.33	Pass

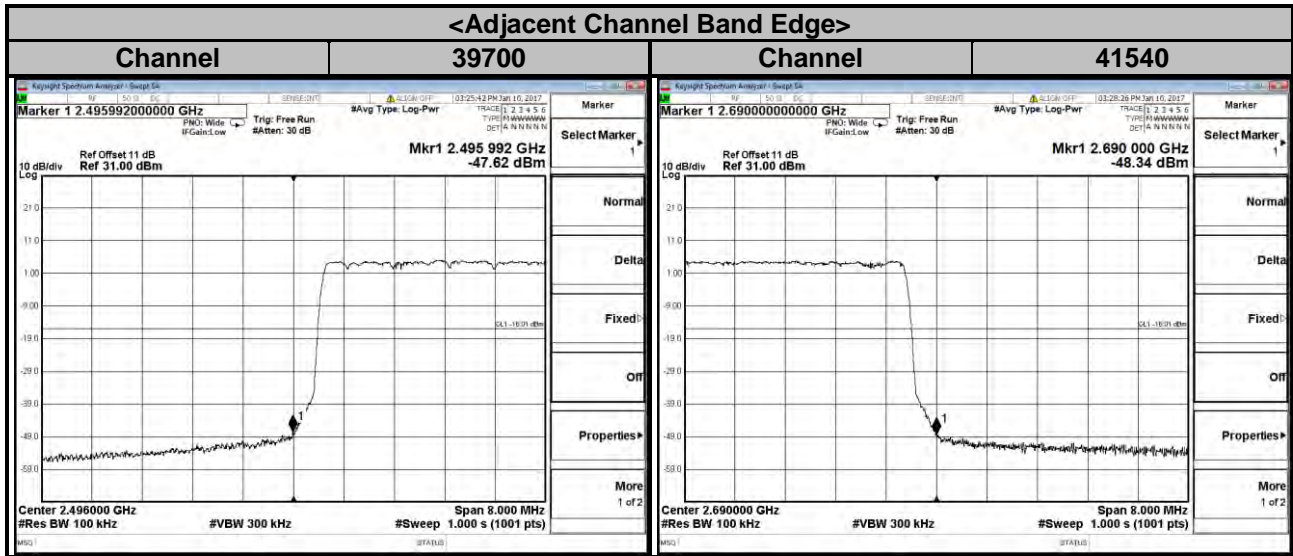

LTE Band 41

Channel Bandwidth: 10 MHz / QPSK

Low Channel 39700

Frequency (MHz)	Measurement Value	Limit	Margin	Result
2490.26	-50.53	-25.00	-25.53	Pass
2495.99	-43.67	-13.00	-30.67	Pass

High Channel 41540

Frequency (MHz)	Measurement Value	Limit	Margin	Result
2690.01	-39.59	-10.00	-29.59	Pass
2695.00	-47.96	-13.00	-34.96	Pass
2705.89	-53.27	-25.00	-28.27	Pass

<Out of Band Emissions >

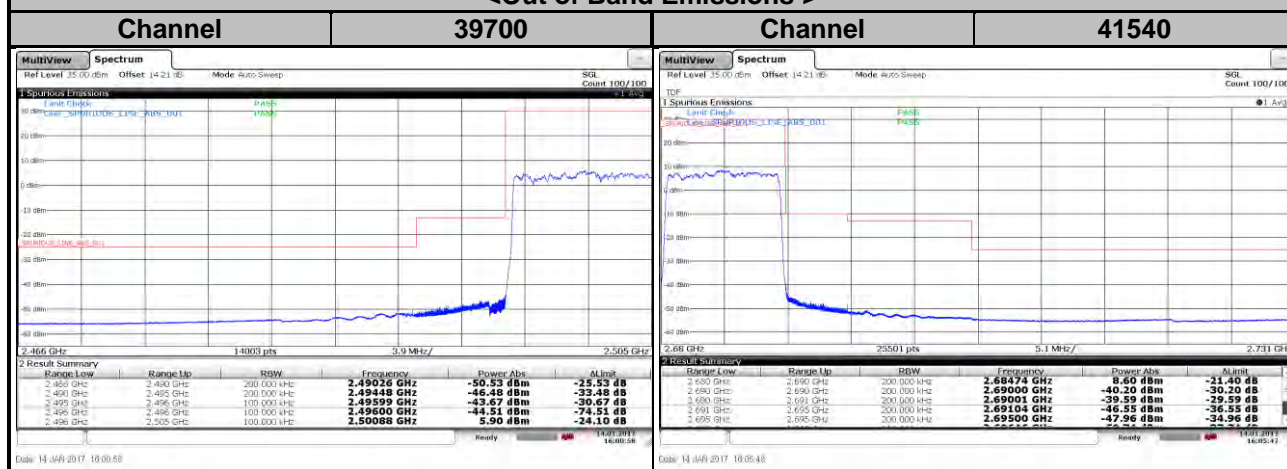

Note: Because the device support MIMO function need to calculate that include 10log (NumbersAnt)
 Setup Loss + cable loss = 11.2 ,
 NumbersAnt = 2 , 10log(2)= 3.01
 Total loss offset = 11.2+3.01=14.21

LTE Band 41				
Channel Bandwidth: 15 MHz / QPSK				
Frequency (MHz)	Measurement Value	Limit	Margin	Result
2495.99	-47.28	-16.01	-31.27	Pass
2690.01	-46.94	-16.01	-30.93	Pass

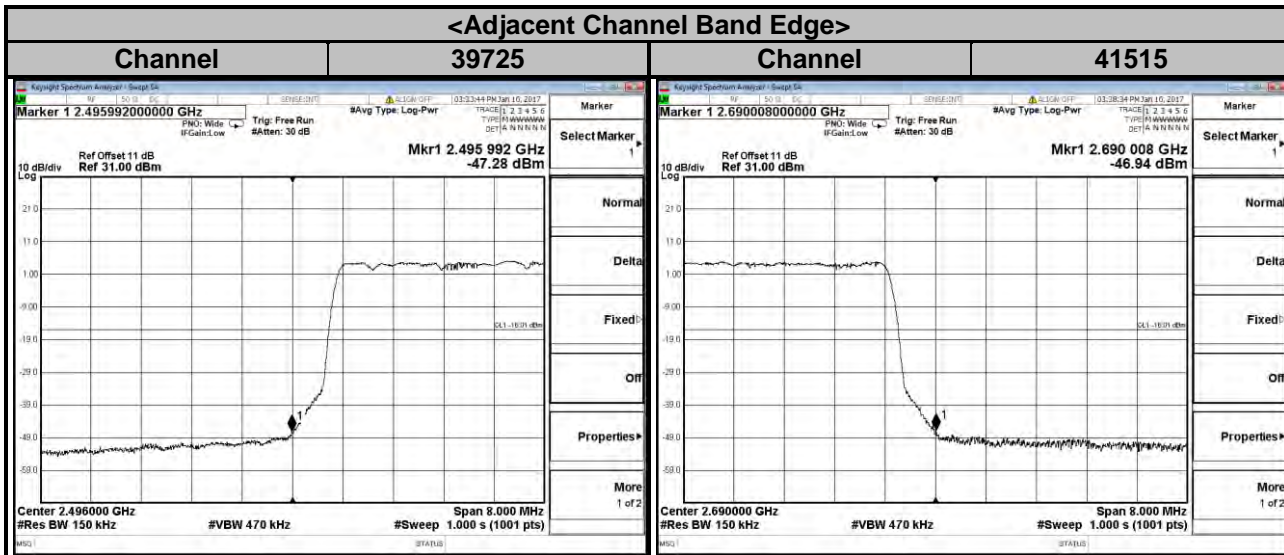

LTE Band 41

Channel Bandwidth: 15 MHz / QPSK

Low Channel 39725

Frequency (MHz)	Measurement Value	Limit	Margin	Result
2490.44	-49.05	-25.00	-24.05	Pass
2496.00	-40.46	-13.00	-27.46	Pass

High Channel 41515

Frequency (MHz)	Measurement Value	Limit	Margin	Result
2690.00	-39.90	-10.00	-29.90	Pass
2695.00	-45.21	-13.00	-32.21	Pass
2706.02	-52.06	-25.00	-27.06	Pass

<Out of Band Emissions >

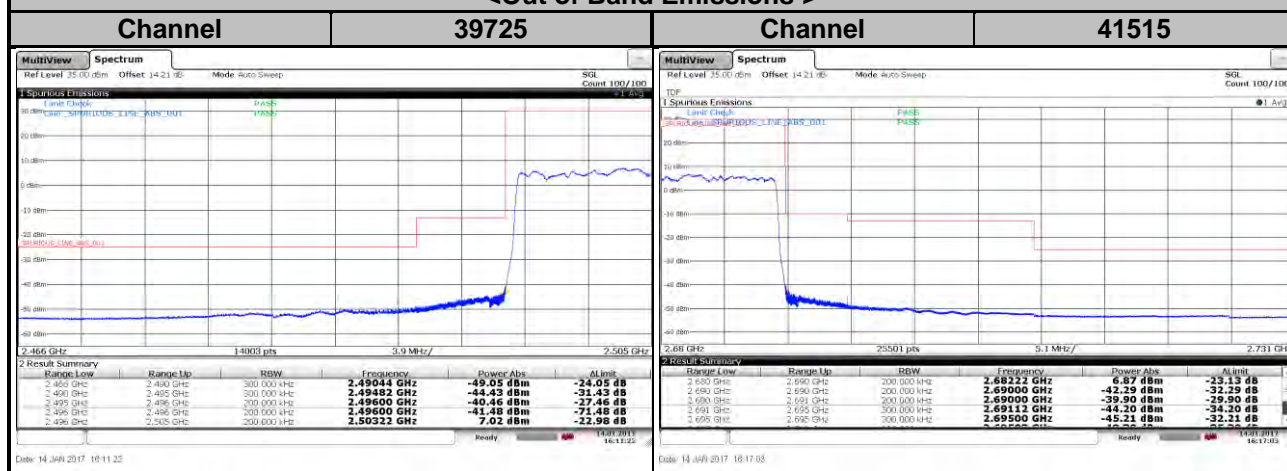

Note: Because the device support MIMO function need to calculate that include 10log (NumbersAnt)
 Setup Loss + cable loss = 11.2 ,
 NumbersAnt = 2 , 10log(2)= 3.01
 Total loss offset = 11.2+3.01=14.21

LTE Band 41				
Channel Bandwidth: 20 MHz / QPSK				
Frequency (MHz)	Measurement Value	Limit	Margin	Result
2495.98	-48.46	-16.01	-32.45	Pass
2690.01	-47.85	-16.01	-31.84	Pass

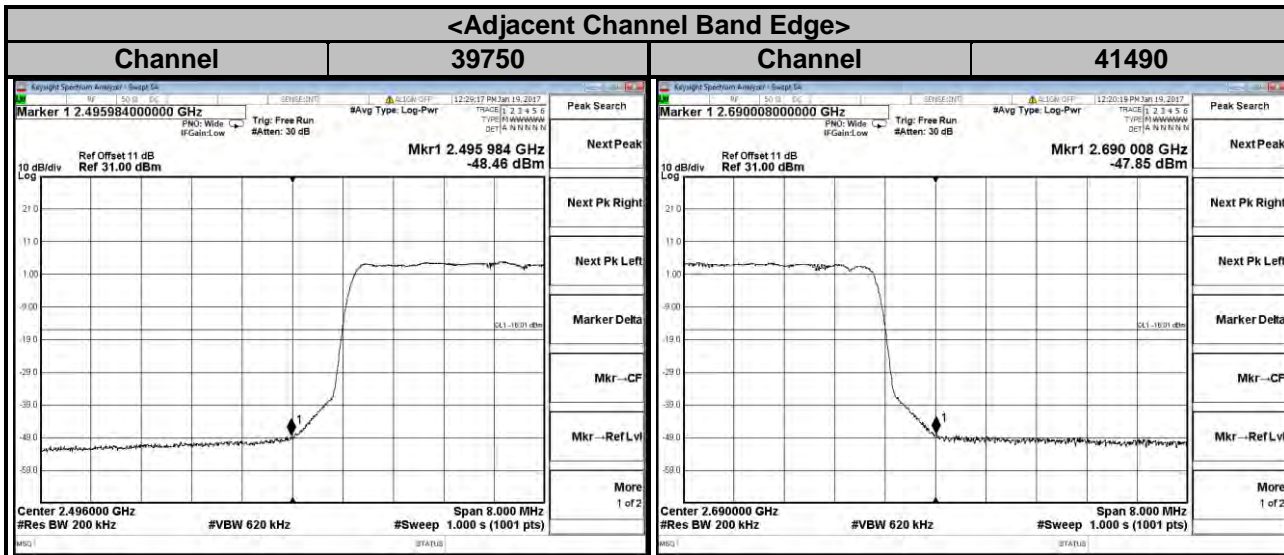

LTE Band 41

Channel Bandwidth: 20 MHz / QPSK

Low Channel 39750

Frequency (MHz)	Measurement Value	Limit	Margin	Result
2490.47	-47.39	-25.00	-22.39	Pass
2496.00	-42.37	-13.00	-29.37	Pass

High Channel 41490

Frequency (MHz)	Measurement Value	Limit	Margin	Result
2690.00	-42.84	-10.00	-32.84	Pass
2695.00	-43.31	-13.00	-30.31	Pass
2705.33	-50.14	-25.00	-25.14	Pass

<Out of Band Emissions >

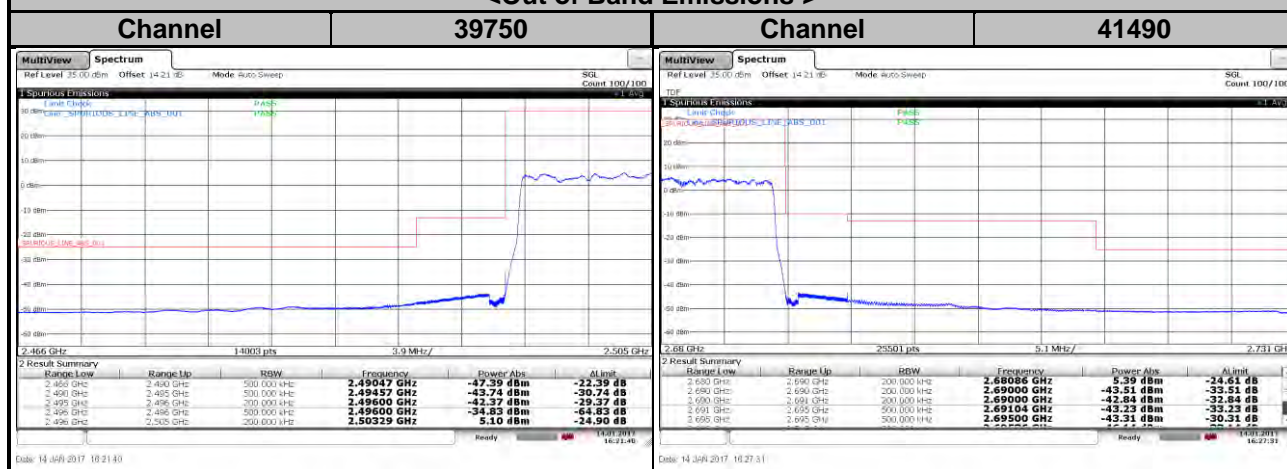

Note: Because the device support MIMO function need to calculate that include 10log (NumbersAnt)
 Setup Loss + cable loss = 11.2 ,
 NumbersAnt = 2 , 10log(2)= 3.01
 Total loss offset = 11.2+3.01=14.21

Chain 0

LTE Band 41				
Channel Bandwidth: 20+20 MHz / QPSK				
Frequency (MHz)	Measurement Value	Limit	Margin	Result
2496.00	-44.36	-16.01	-28.35	Pass
2690.00	-44.79	-16.01	-28.78	Pass

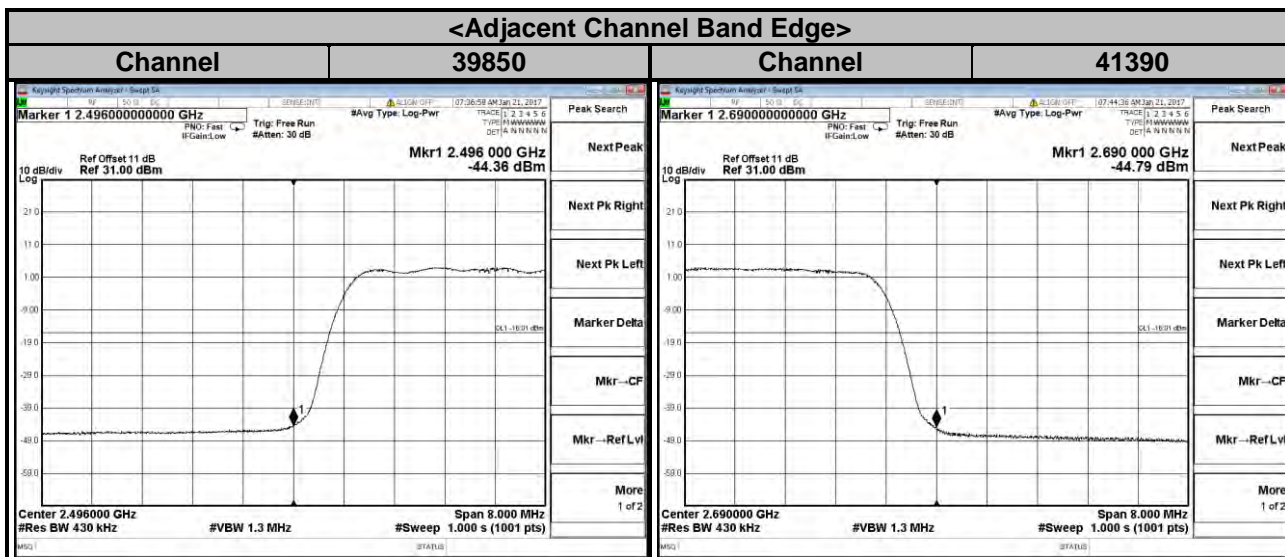

LTE Band 41

Channel Bandwidth: 20+20 MHz / QPSK

Low Channel 39850

Frequency (MHz)	Measurement Value	Limit	Margin	Result
2488.66	-37.44	-25.00	-12.44	Pass
2495.94	-32.14	-13.00	-19.14	Pass

High Channel 41390

Frequency (MHz)	Measurement Value	Limit	Margin	Result
2690.03	-10.06	-10.00	-0.06	Pass
2695.00	-39.65	-13.00	-26.65	Pass
2735.03	-46.37	-25.00	-21.37	Pass

<Out of Band Emissions >

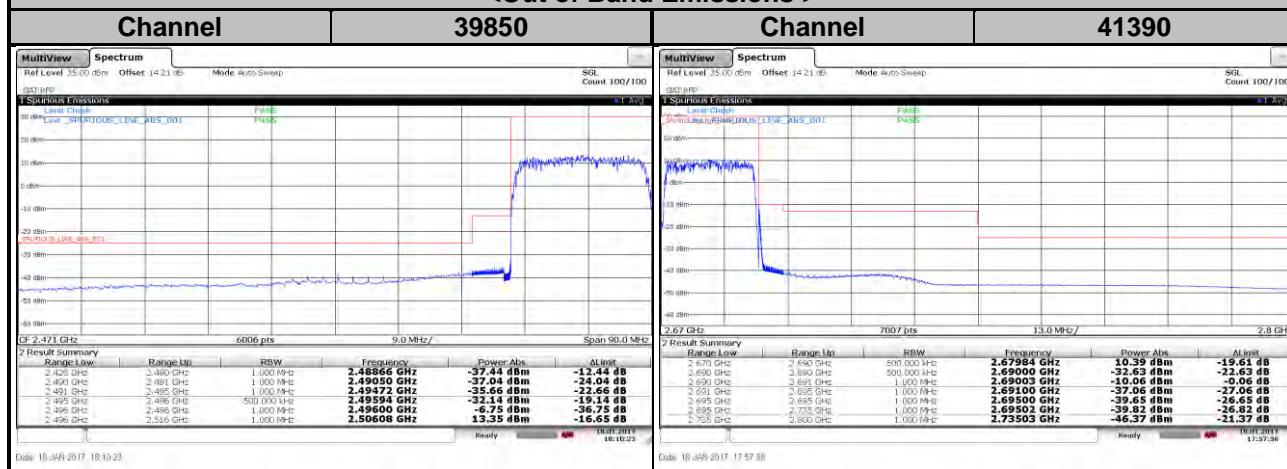

Note: Because the device support MIMO function need to calculate that include 10log (NumbersAnt)
 Setup Loss + cable loss = 11.2 ,
 NumbersAnt = 2 , 10log(2)= 3.01
 Total loss offset = 11.2+3.01=14.21

Chain 1

LTE Band 41				
Channel Bandwidth: 20+20 MHz / QPSK				
Frequency (MHz)	Measurement Value	Limit	Margin	Result
2496.00	-44.77	-16.01	-28.76	Pass
2690.00	-44.97	-16.01	-28.96	Pass

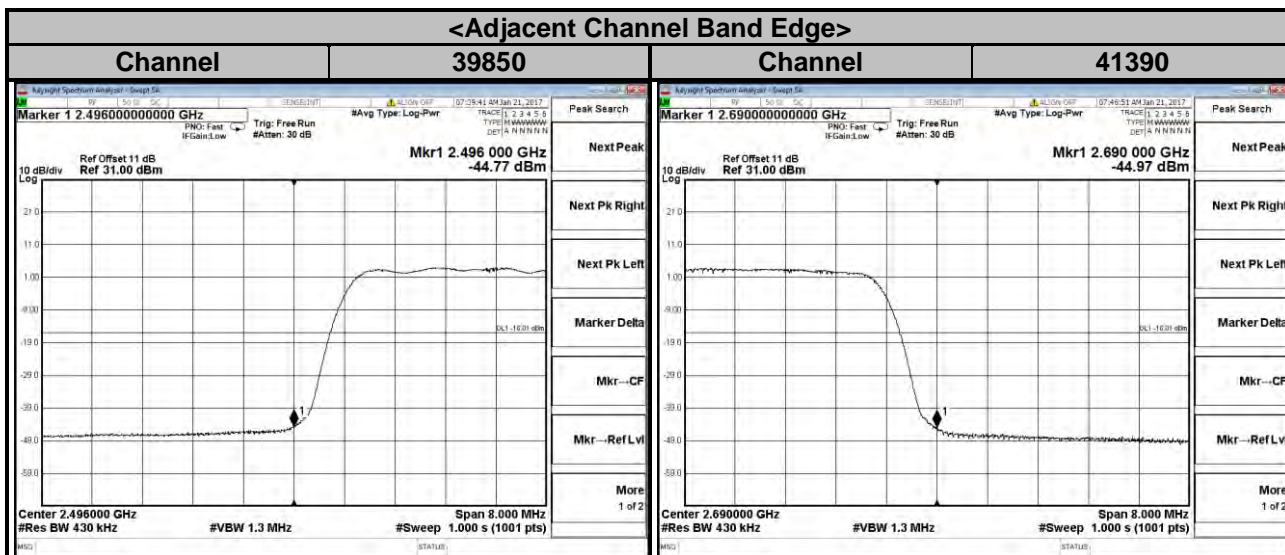

LTE Band 41

Channel Bandwidth: 20+20 MHz / QPSK

Low Channel 39850

Frequency (MHz)	Measurement Value	Limit	Margin	Result
2488.66	-39.10	-25.00	-14.10	Pass
2495.94	-32.22	-13.00	-19.22	Pass

High Channel 41390

Frequency (MHz)	Measurement Value	Limit	Margin	Result
2690.03	-10.10	-10.00	-0.10	Pass
2695.00	-39.72	-13.00	-26.72	Pass
2742.69	-46.37	-25.00	-21.37	Pass

<Out of Band Emissions >

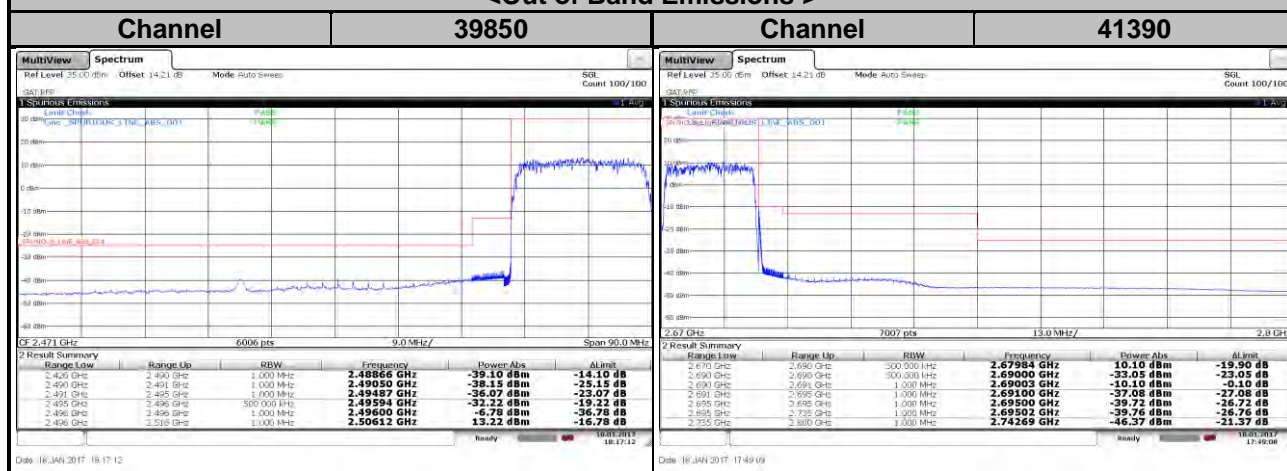

Note: Because the device support MIMO function need to calculate that include 10log (NumbersAnt)
 Setup Loss + cable loss = 11.2 ,
 NumbersAnt = 2 , 10log(2)= 3.01
 Total loss offset = 11.2+3.01=14.21

4.5 Peak to Average Ratio

4.5.1 Limits of Peak to Average Ratio Measurement

In measuring transmissions in this band using an average power technique, the peak to-average ratio (PAR) of the transmission may not exceed 13 dB.

4.5.2 Test Setup

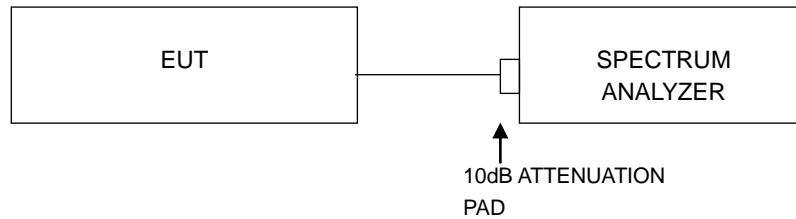

4.5.3 Test Procedures

For 10 ~ 20 MHz

1. Set resolution/measurement bandwidth \geq signal's occupied bandwidth;
2. Set the number of counts to a value that stabilizes the measured CCDF curve;
3. Record the maximum PAPR level associated with a probability of 0.1 %.

For 20+20 MHz

1. The nominal resolution bandwidth (RBW) shall be in the range of 1 to 5 % of the anticipated OBW to measure the total peak power and record as P_{Pk} .
2. The nominal resolution bandwidth (RBW) shall be in the range of 1 to 5 % of the anticipated OBW to measure the total average power and record as P_{Avg} .
3. $PAPR (dB) = P_{Pk} (dBm) - P_{Avg} (dBm)$.

4.5.4 Test Results

Chain 0

LTE Band 41				
Channel Bandwidth: 10 MHz				
Channel	Frequency (MHz)	Peak to Average Ratio (dB)		
		QPSK	16QAM	64QAM
39700	2501.0	8.50	9.08	9.30
40620	2593.0	8.76	8.88	9.18
41540	2685.0	8.69	8.82	9.03

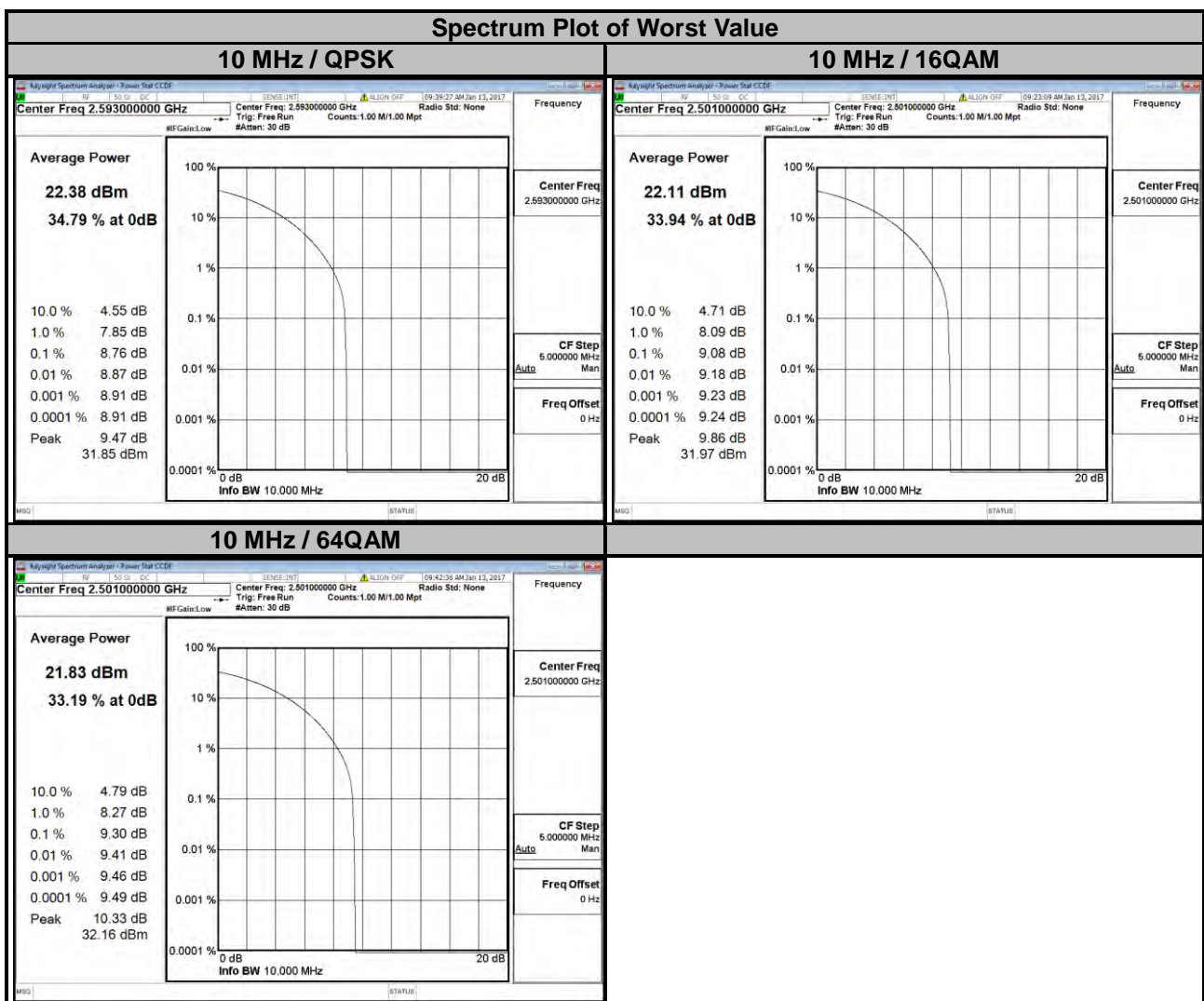

LTE Band 41

Channel Bandwidth: 15 MHz

Channel	Frequency (MHz)	Peak to Average Ratio (dB)		
		QPSK	16QAM	64QAM
39725	2503.5	8.76	8.70	9.24
40620	2593.0	8.38	8.83	8.85
41515	2682.5	8.44	8.56	8.75

Spectrum Plot of Worst Value

15 MHz / QPSK

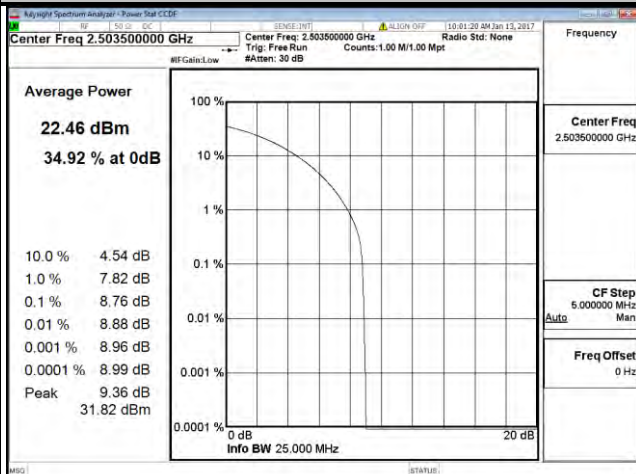

15 MHz / 16QAM

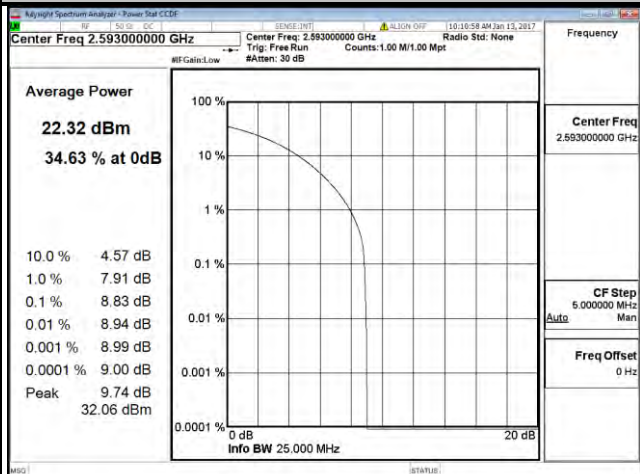

15 MHz / 64QAM

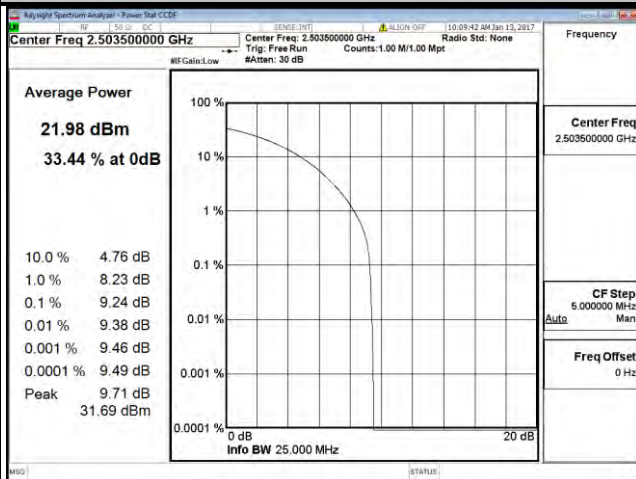

LTE Band 41

Channel Bandwidth: 20 MHz

Channel	Frequency (MHz)	Peak to Average Ratio (dB)		
		QPSK	16QAM	64QAM
39725	2503.5	8.34	8.49	8.64
40620	2593.0	8.64	8.89	9.57
41515	2682.5	8.50	8.56	8.66

Spectrum Plot of Worst Value

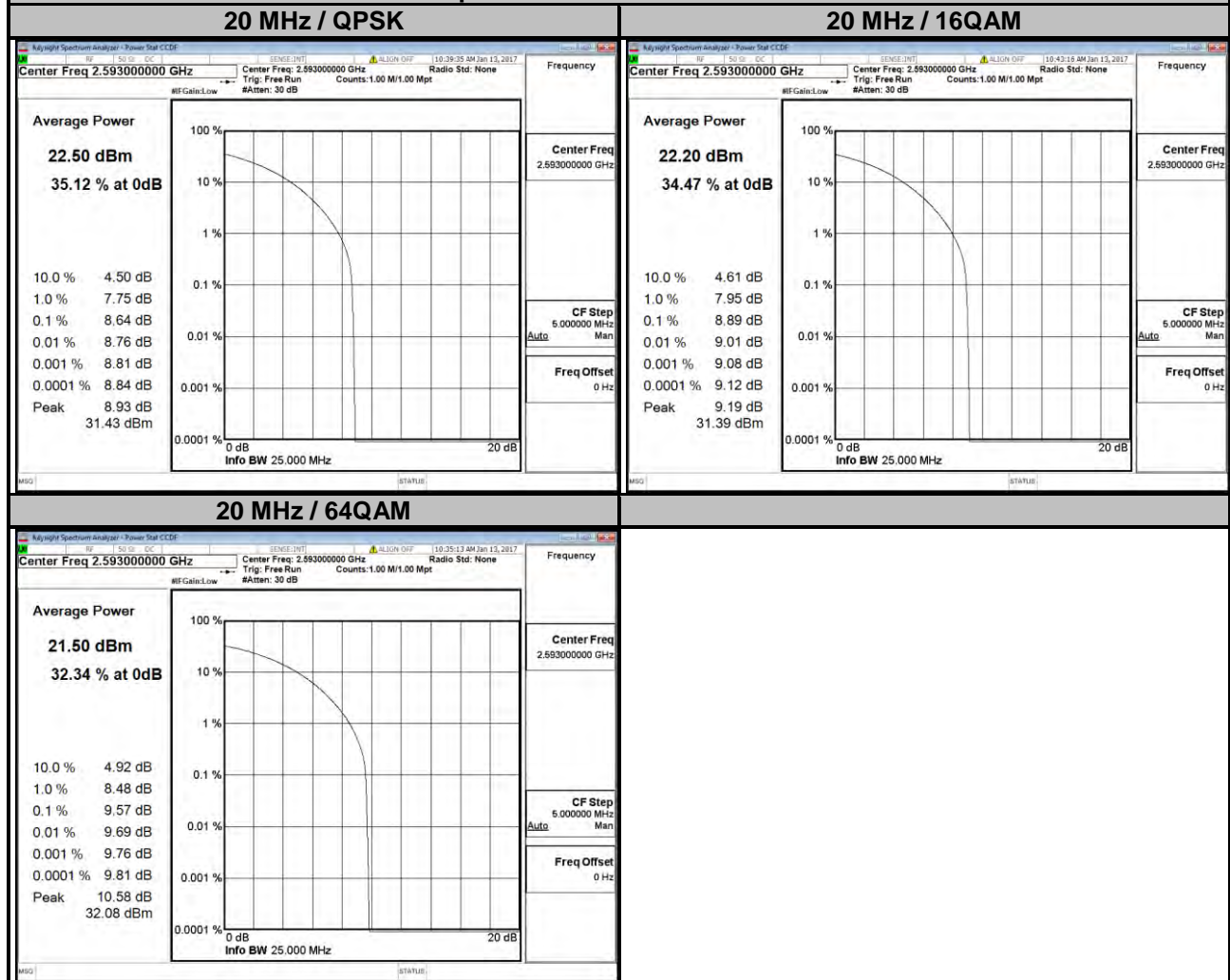

Chain 1

LTE Band 41				
Channel Bandwidth: 10 MHz				
Channel	Frequency (MHz)	Peak to Average Ratio (dB)		
		QPSK	16QAM	64QAM
39700	2501.0	8.46	8.96	9.12
40620	2593.0	8.74	8.88	9.13
41540	2685.0	7.96	8.61	9.33

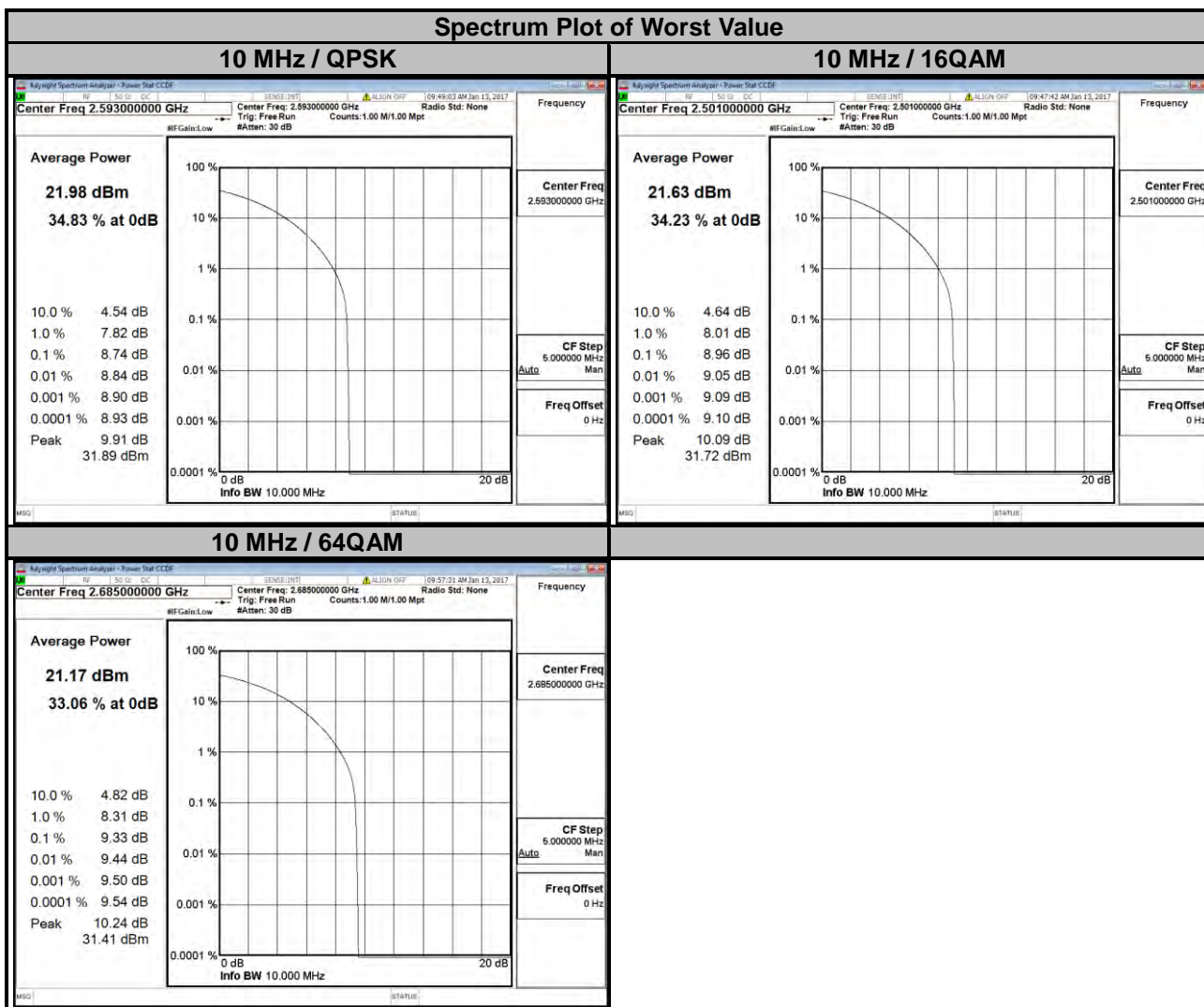

LTE Band 41

Channel Bandwidth: 15 MHz

Channel	Frequency (MHz)	Peak to Average Ratio (dB)		
		QPSK	16QAM	64QAM
39725	2503.5	8.37	8.81	9.37
40620	2593.0	7.60	8.23	8.55
41515	2682.5	7.82	8.71	9.13

Spectrum Plot of Worst Value

15 MHz / QPSK

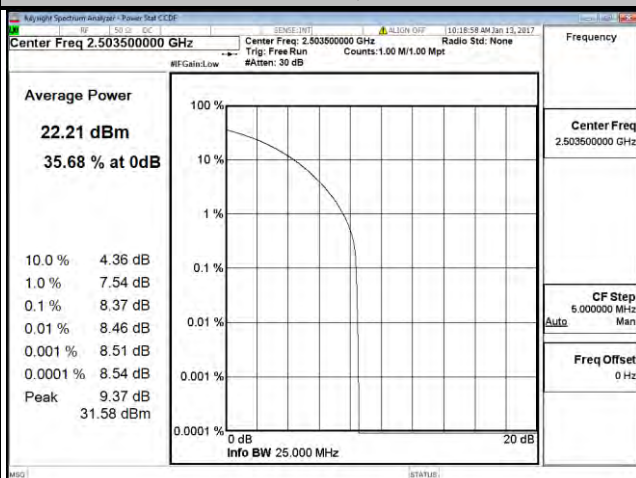

15 MHz / 16QAM

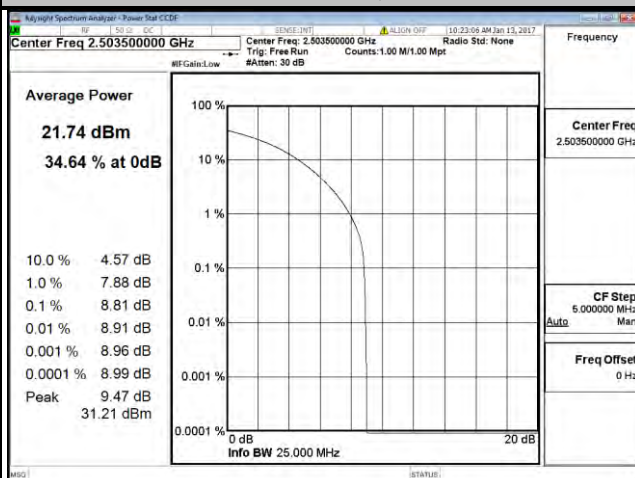

15 MHz / 64QAM

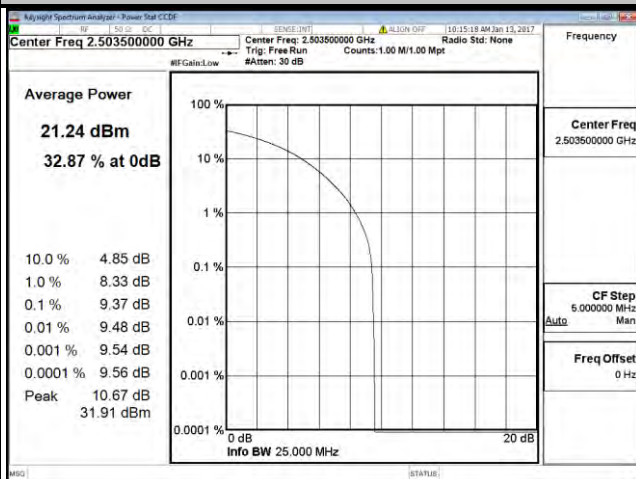

LTE Band 41

Channel Bandwidth: 20 MHz

Channel	Frequency (MHz)	Peak to Average Ratio (dB)		
		QPSK	16QAM	64QAM
39725	2503.5	8.25	8.93	9.56
40620	2593.0	8.34	9.03	9.07
41515	2682.5	8.48	8.71	9.24

Spectrum Plot of Worst Value

20 MHz / QPSK

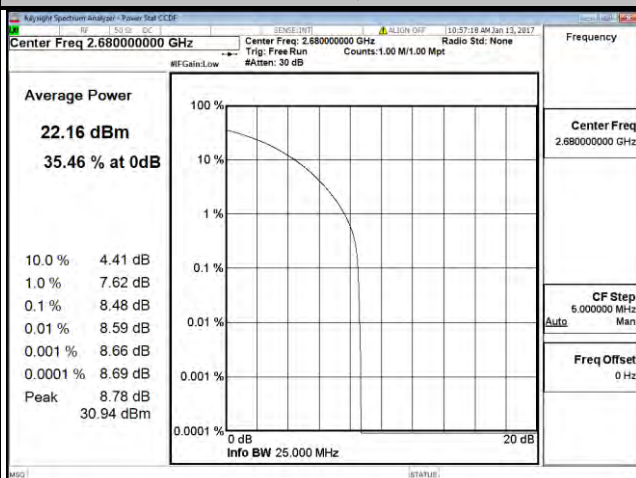

20 MHz / 16QAM

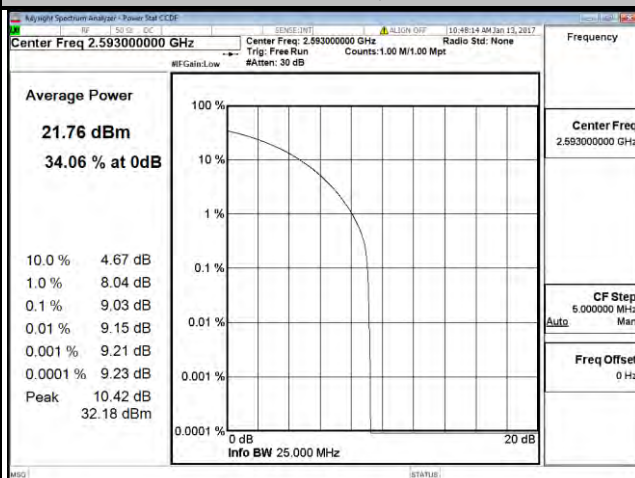

20 MHz / 64QAM

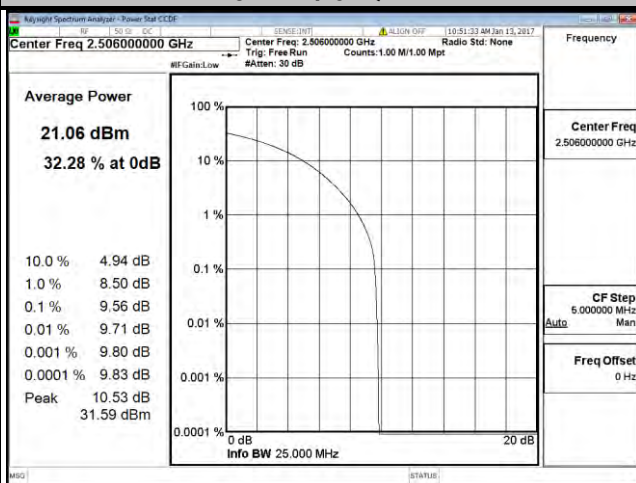

Chain 0

LTE Band 41				
Channel Bandwidth: 20+20 MHz				
Channel	Frequency (MHz)	Peak to Average Ratio (dB)		
		QPSK	16QAM	64QAM
39850	2501.0	6.56	6.67	6.67
40620	2593.0	7.35	7.17	7.25
41390	2685.0	7.36	7.55	7.62

Spectrum Plot of Worst Value
20+20 MHz / QPSK

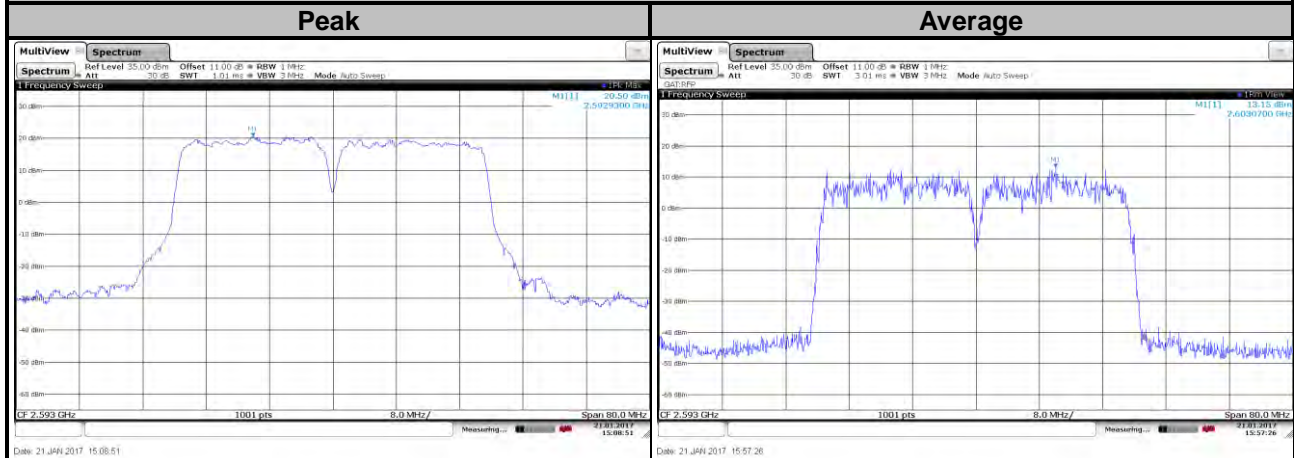

20+20 MHz / 16QAM

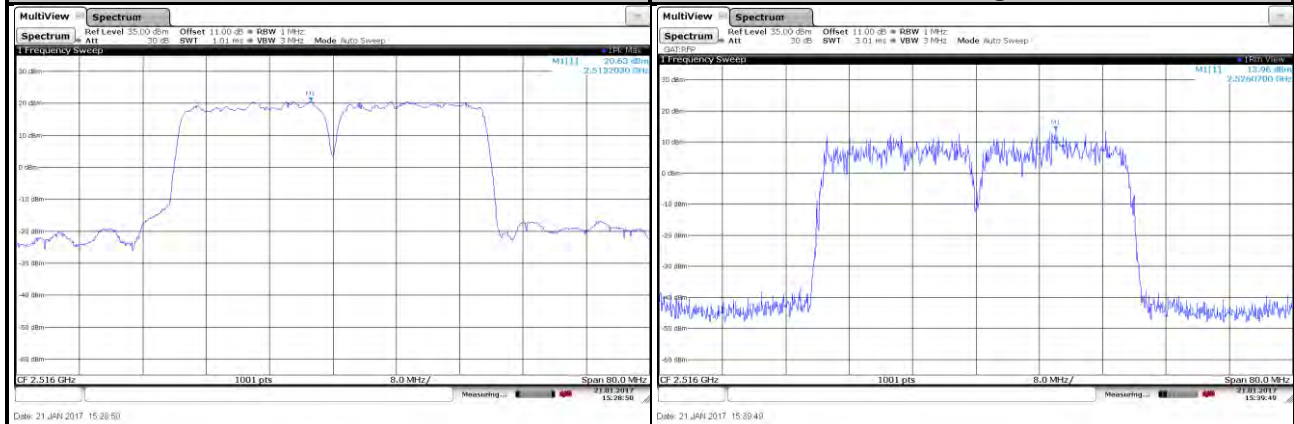

20+20 MHz / 64QAM

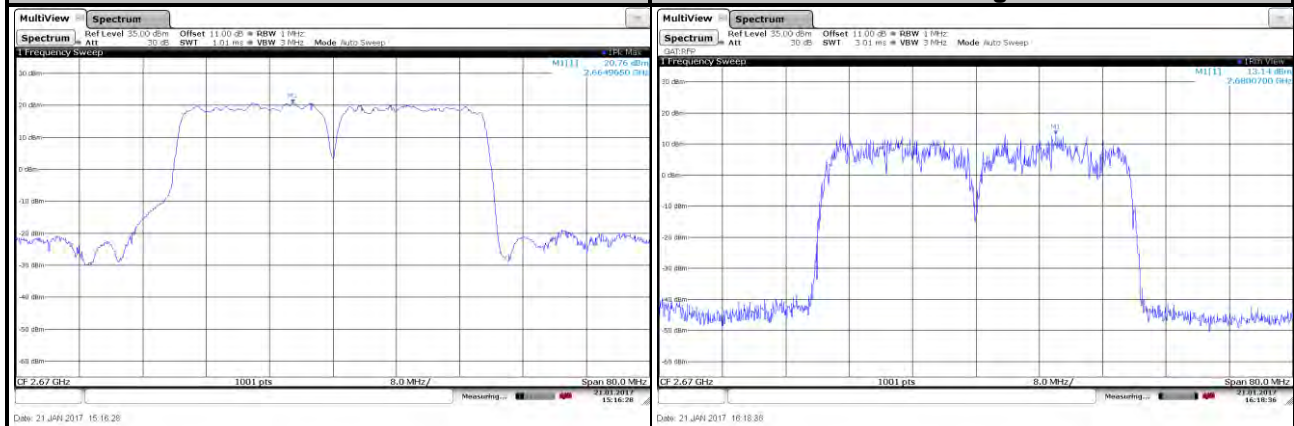

Chain 1

LTE Band 41				
Channel Bandwidth: 20+20 MHz				
Channel	Frequency (MHz)	Peak to Average Ratio (dB)		
		QPSK	16QAM	64QAM
39850	2501.0	7.33	7.43	7.38
40620	2593.0	7.77	7.85	7.65
41390	2685.0	7.34	7.42	7.57

Spectrum Plot of Worst Value
20+20 MHz / QPSK

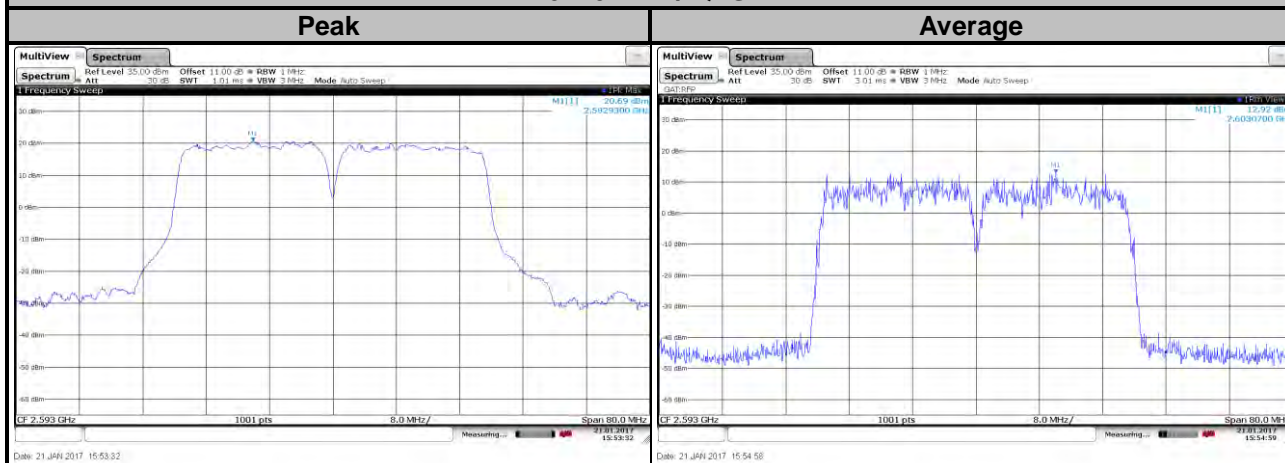

20+20 MHz / 16QAM

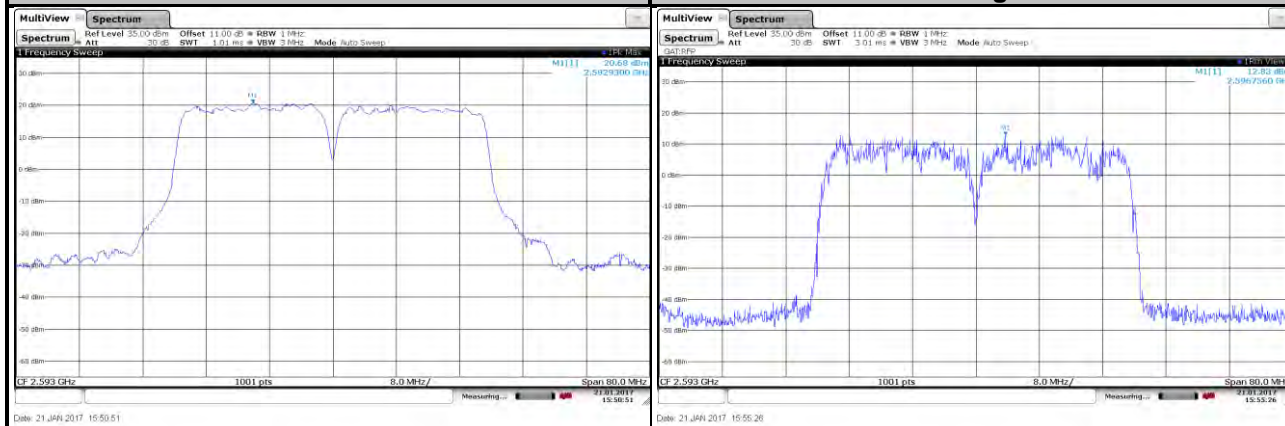

20+20 MHz / 64QAM

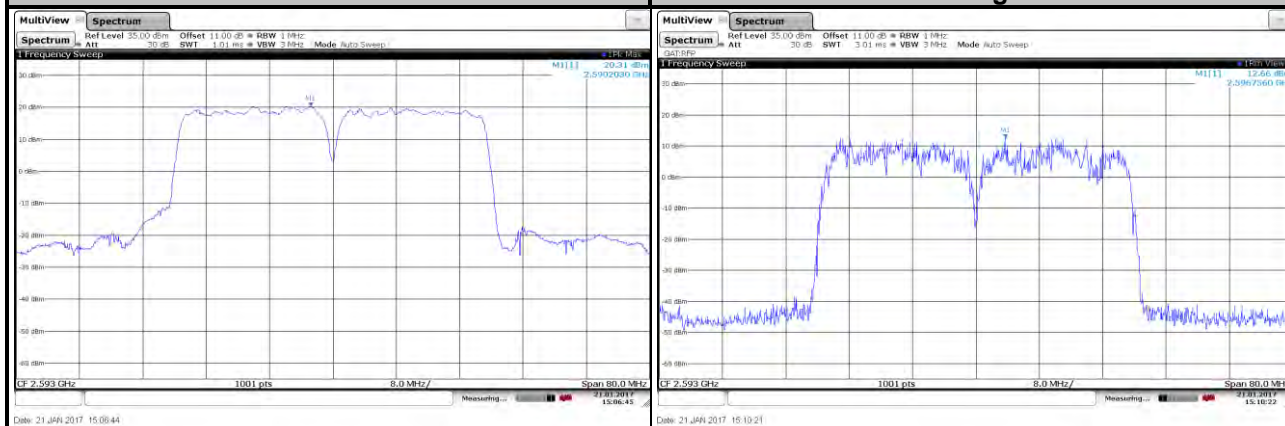

4.6 Conducted Spurious Emissions

4.6.1 Limits of Conducted Spurious Emissions Measurement

The power of any emission outside a licensee's frequency block shall be attenuated below the transmitter power (P) by at least $55 + 10 \log_{10}(P)$ dB. The limit of emission is equal to -25 dBm.

Note:

This device can be implement MIMO function, so the limit of spurious emissions needs to be reduced by $10 \log(\text{Numbers}_{\text{Ant}})$ according to FCC KDB 662911 D01 guidance.

{The limit is adjusted to $-25 \text{dBm} - 10 * \log(2) = -28.01 \text{dBm}$.}

4.6.2 Test Setup

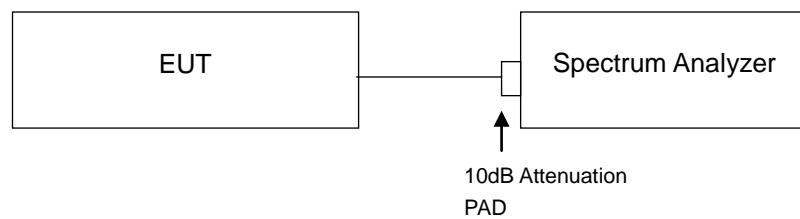

4.6.3 Test Procedure

- The EUT makes a phone call to the communication simulator. All measurements were done at low, middle and high operational frequency range.
- Measuring frequency range is from 30 MHz to 27 GHz for LTE Band 41. 10dB attenuation pad is connected with spectrum. RBW=1MHz and VBW=3MHz are used for conducted emission measurement.

4.6.4 Test Results

Chain 0

LTE Band 41				
Channel Bandwidth: 10 MHz				
Low Channel 39700				
Frequency (MHz)	Measurement Value	Limit	Margin	Result
2640.61	-35.23	-28.01	-7.22	Pass
26680.80	-60.53	-28.01	-32.52	Pass
Mid Channel 40620				
Frequency (MHz)	Measurement Value	Limit	Margin	Result
2791.35	-37.71	-28.01	-9.7	Pass
7781.00	-57.90	-28.01	-29.89	Pass
High Channel 41540				
Frequency (MHz)	Measurement Value	Limit	Margin	Result
2801.74	-36.82	-28.01	-8.81	Pass
26091.60	-60.16	-28.01	-32.15	Pass

LTE Band 41
Channel Bandwidth: 10 MHz
Channel 39700

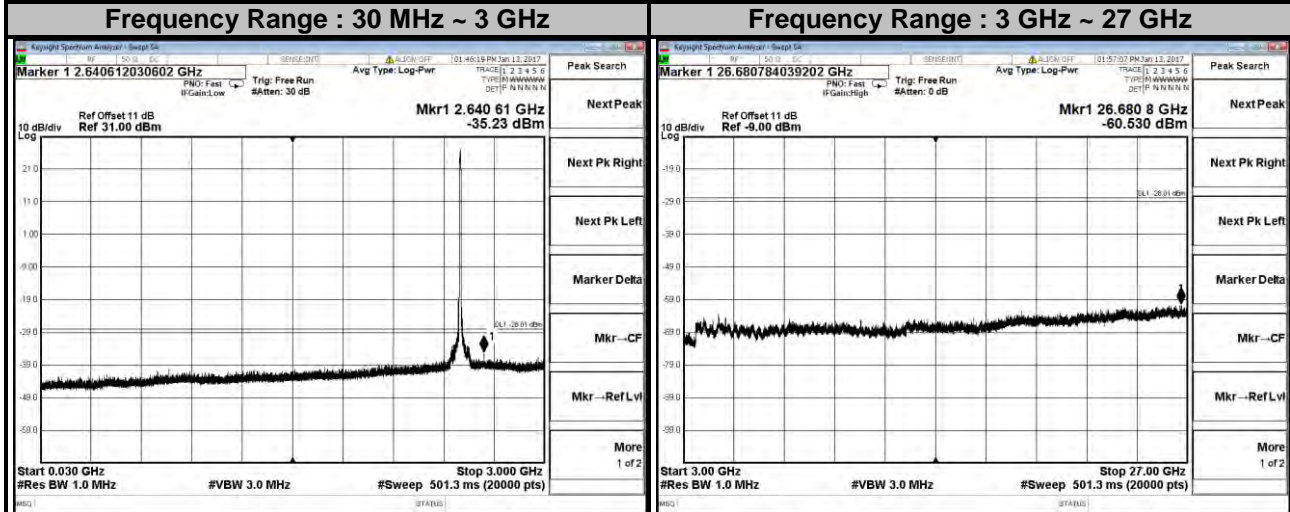

Channel 40620

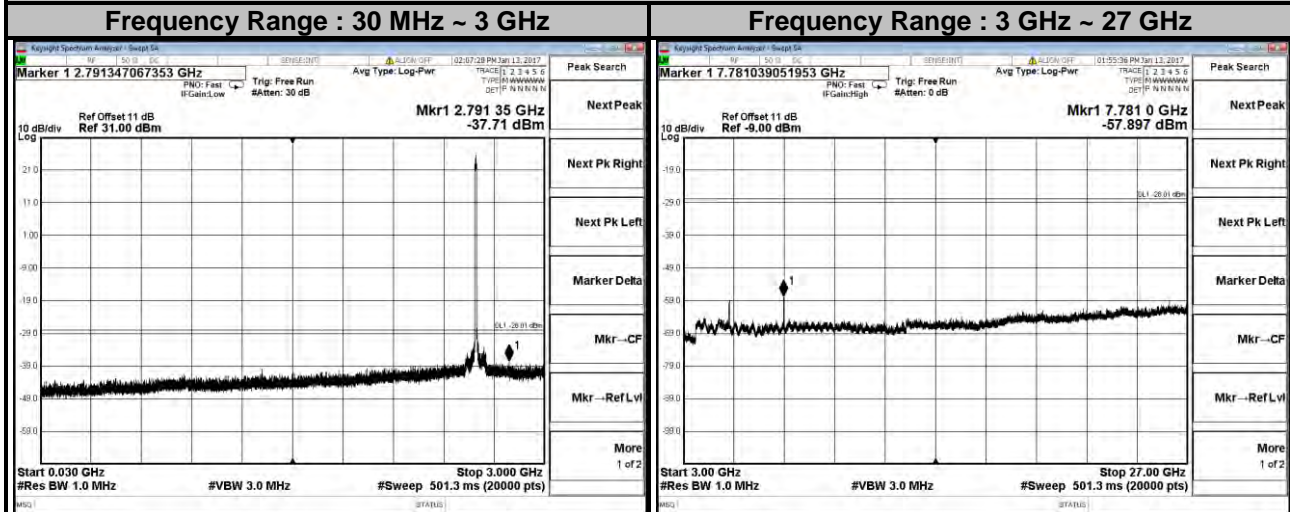

Channel 41540

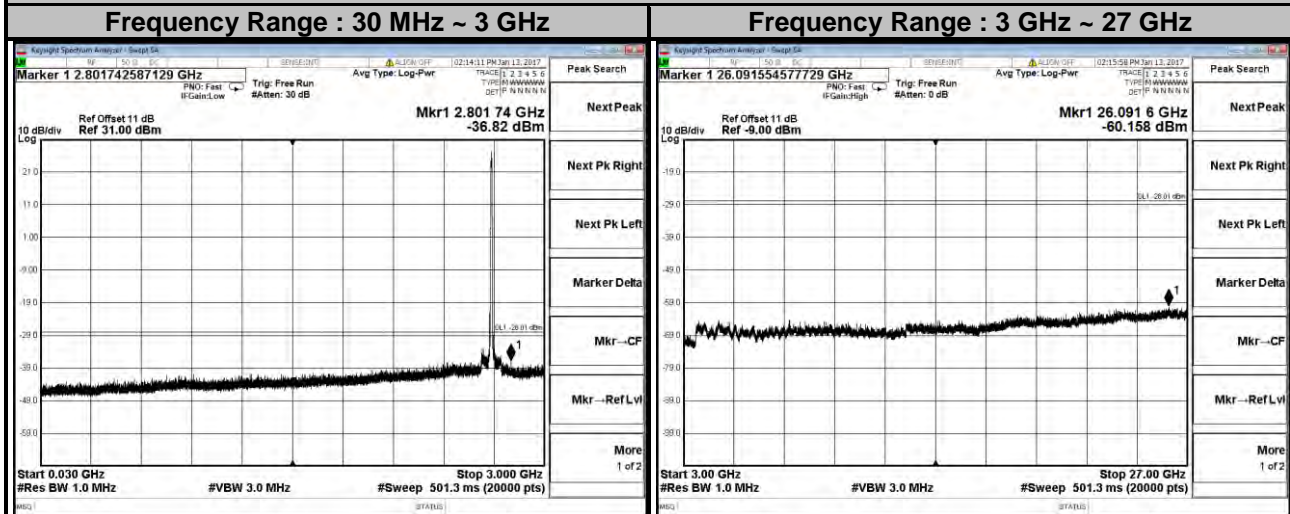

LTE Band 41

Channel Bandwidth: 15 MHz

Low Channel 39725

Frequency (MHz)	Measurement Value	Limit	Margin	Result
2773.53	-36.54	-28.01	-8.53	Pass
26080.80	-60.39	-28.01	-32.38	Pass

Mid Channel 40620

Frequency (MHz)	Measurement Value	Limit	Margin	Result
2844.36	-36.50	-28.01	-8.49	Pass
26392.80	-59.76	-28.01	-31.75	Pass

High Channel 41515

Frequency (MHz)	Measurement Value	Limit	Margin	Result
2924.86	-36.74	-28.01	-8.73	Pass
26150.40	-60.29	-28.01	-32.28	Pass

LTE Band 41
Channel Bandwidth: 15 MHz
Channel 39725

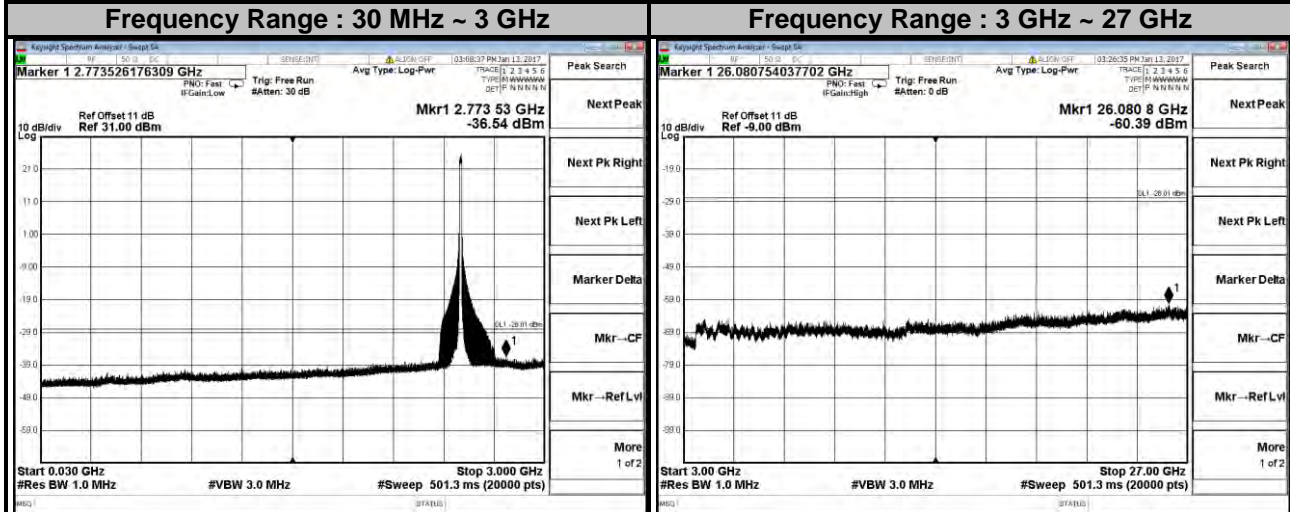

Channel 40620

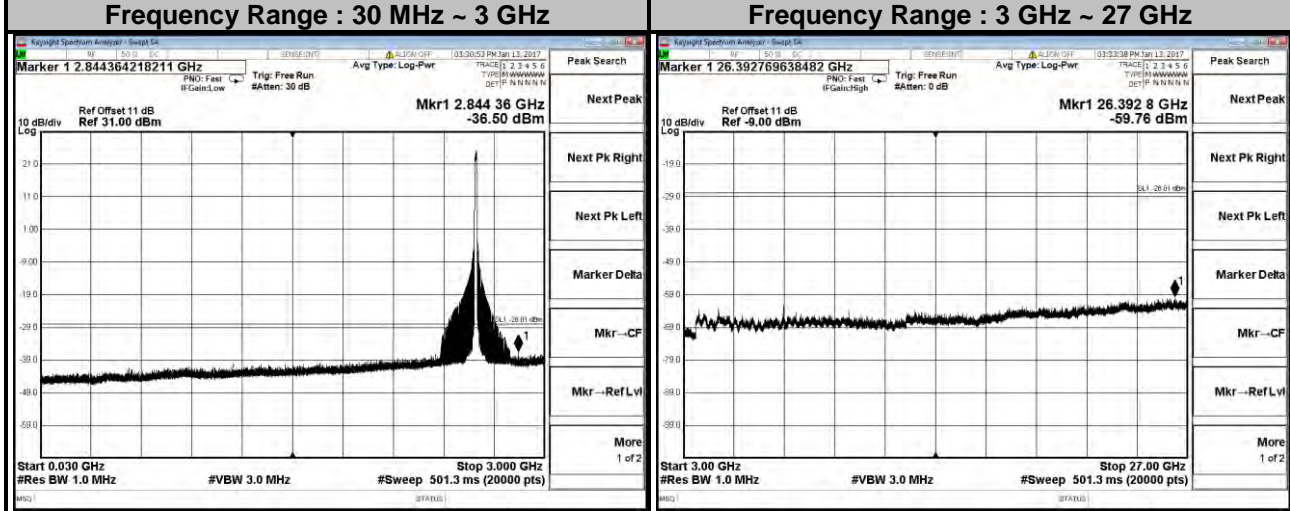

Channel 41515

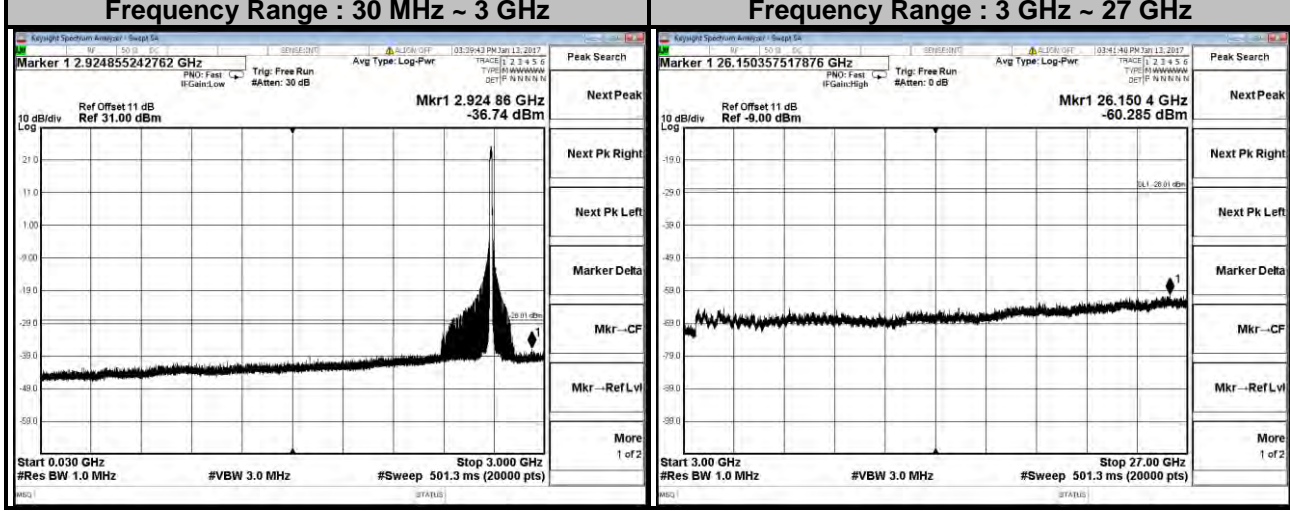

LTE Band 41

Channel Bandwidth: 20 MHz

Low Channel 39750

Frequency (MHz)	Measurement Value	Limit	Margin	Result
2659.18	-36.51	-28.01	-8.5	Pass
25995.50	-60.66	-28.01	-32.65	Pass

Mid Channel 40620

Frequency (MHz)	Measurement Value	Limit	Margin	Result
2822.83	-36.87	-28.01	-8.86	Pass
26116.80	-60.51	-28.01	-32.50	Pass

High Channel 41490

Frequency (MHz)	Measurement Value	Limit	Margin	Result
2957.97	-36.29	-28.01	-8.28	Pass
24389.90	-60.62	-28.01	-32.61	Pass

LTE Band 41

Channel Bandwidth: 20 MHz

Channel 39750

Frequency Range : 30 MHz ~ 3 GHz

Frequency Range : 3 GHz ~ 27 GHz

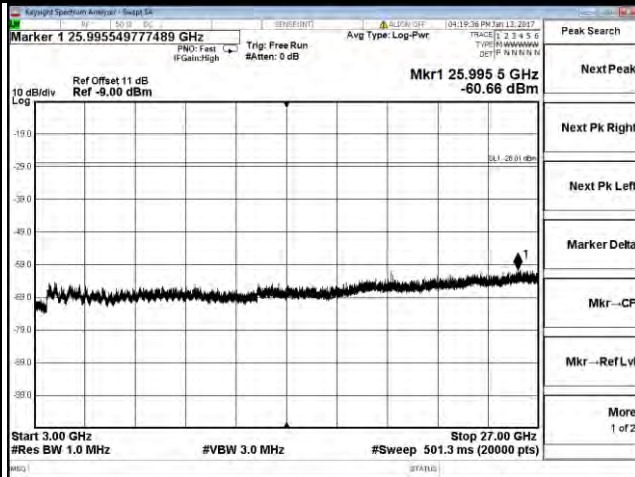
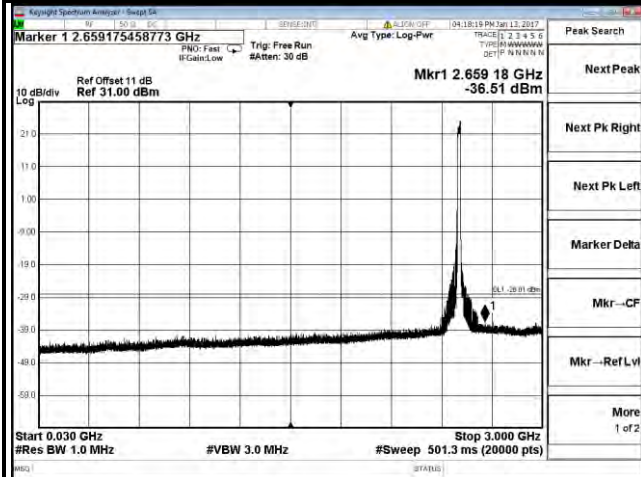

Channel 40620

Frequency Range : 30 MHz ~ 3 GHz

Frequency Range : 3 GHz ~ 27 GHz

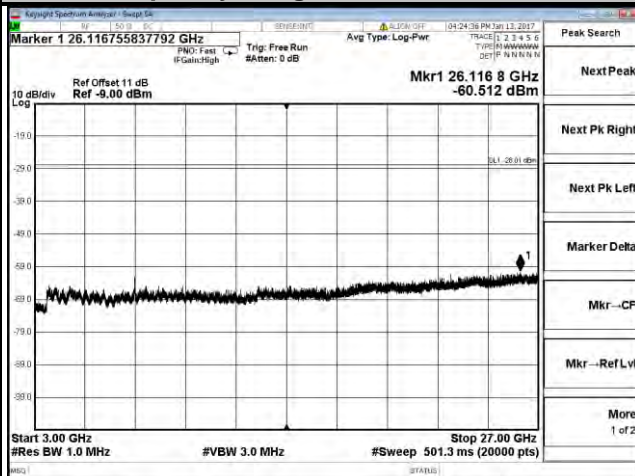
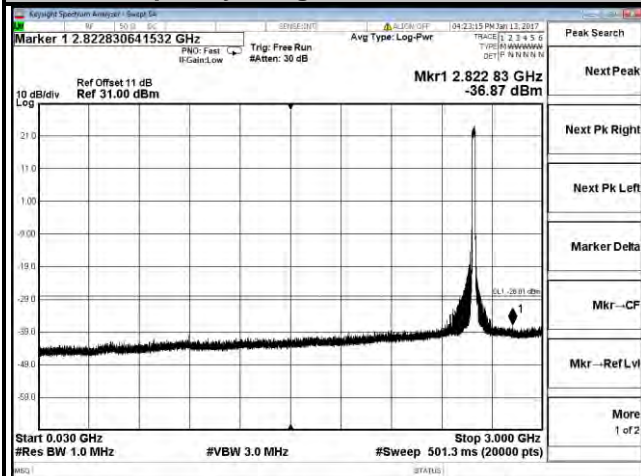

Channel 41490

Frequency Range : 30 MHz ~ 3 GHz

Frequency Range : 3 GHz ~ 27 GHz

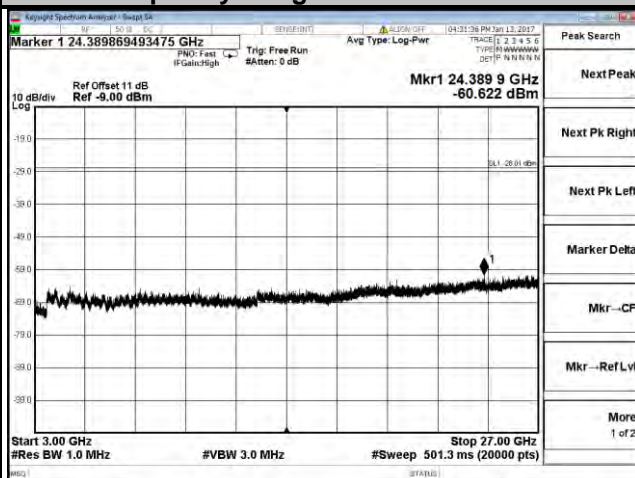
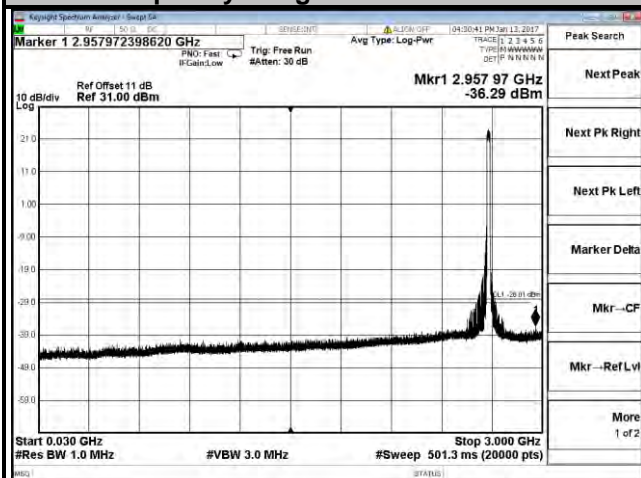

Chain 1

LTE Band 41				
Channel Bandwidth: 10 MHz				
Low Channel 39700				
Frequency (MHz)	Measurement Value	Limit	Margin	Result
2745.76	-36.83	-28.01	-8.82	Pass
26480.40	-60.755	-28.01	-32.745	Pass
Mid Channel 40620				
Frequency (MHz)	Measurement Value	Limit	Margin	Result
2732.09	-36.78	-28.01	-8.77	Pass
7787.00	-59.76	-28.01	-31.75	Pass
High Channel 41540				
Frequency (MHz)	Measurement Value	Limit	Margin	Result
2943.12	-36.58	-28.01	-8.57	Pass
26362.80	-60.07	-28.01	-32.06	Pass

LTE Band 41

Channel Bandwidth: 10 MHz

Channel 39700

Frequency Range : 30 MHz ~ 3 GHz

Frequency Range : 3 GHz ~ 27 GHz

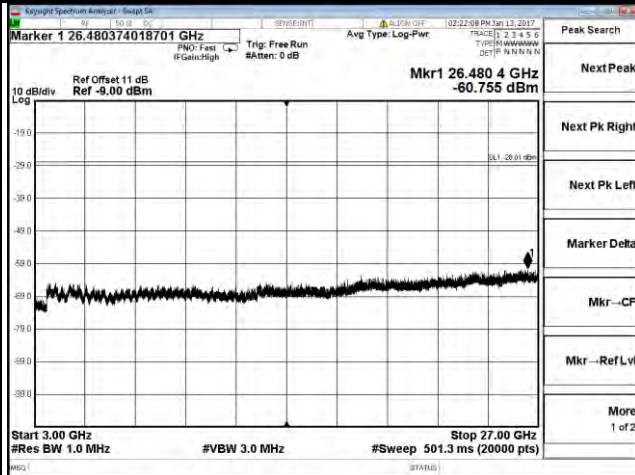
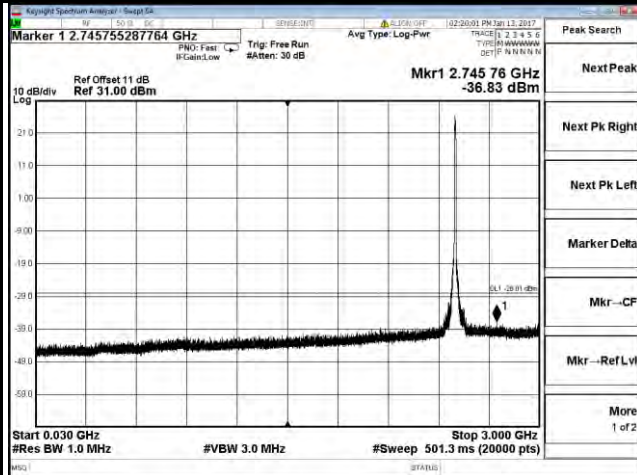

Channel 40620

Frequency Range : 30 MHz ~ 3 GHz

Frequency Range : 3 GHz ~ 27 GHz

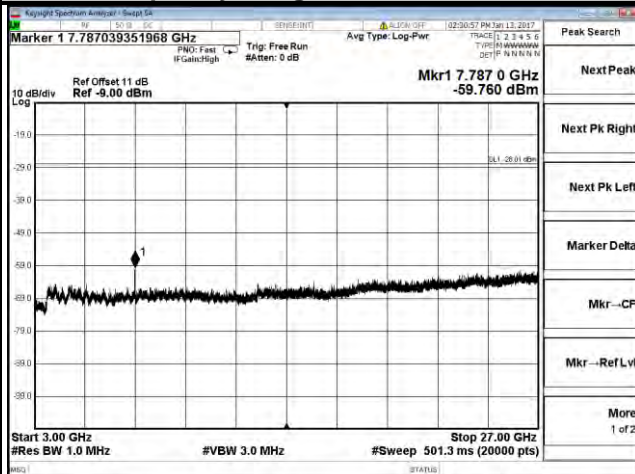
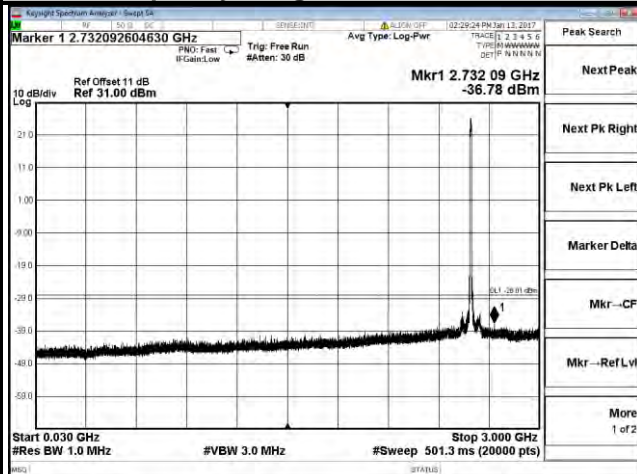

Channel 41540

Frequency Range : 30 MHz ~ 3 GHz

Frequency Range : 3 GHz ~ 27 GHz

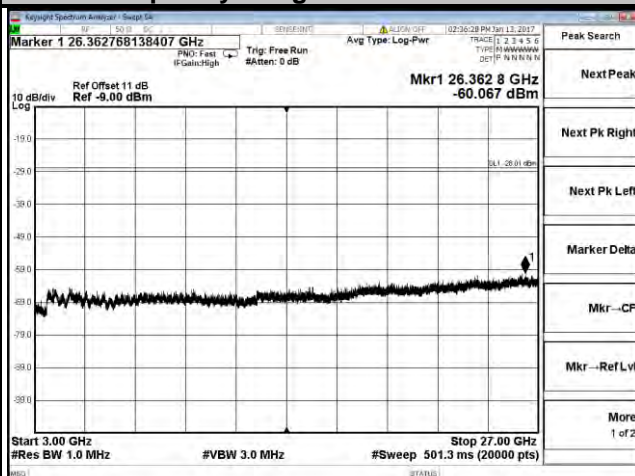
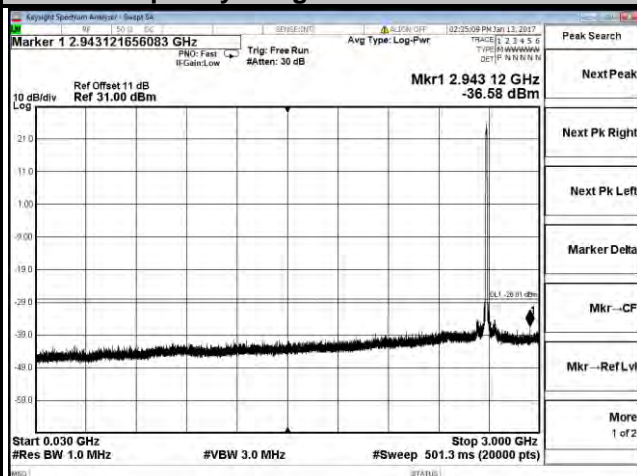

LTE Band 41

Channel Bandwidth: 15 MHz

Low Channel 39725

Frequency (MHz)	Measurement Value	Limit	Margin	Result
2839.31	-36.79	-28.01	-8.78	Pass
26079.60	-60.27	-28.01	-32.26	Pass

Mid Channel 40620

Frequency (MHz)	Measurement Value	Limit	Margin	Result
2967.48	-36.99	-28.01	-8.98	Pass
26023.20	-60.24	-28.01	-32.23	Pass

High Channel 41515

Frequency (MHz)	Measurement Value	Limit	Margin	Result
2963.32	-36.50	-28.01	-8.49	Pass
26796.00	-59.46	-28.01	-31.45	Pass

LTE Band 41
Channel Bandwidth: 15 MHz
Channel 39725

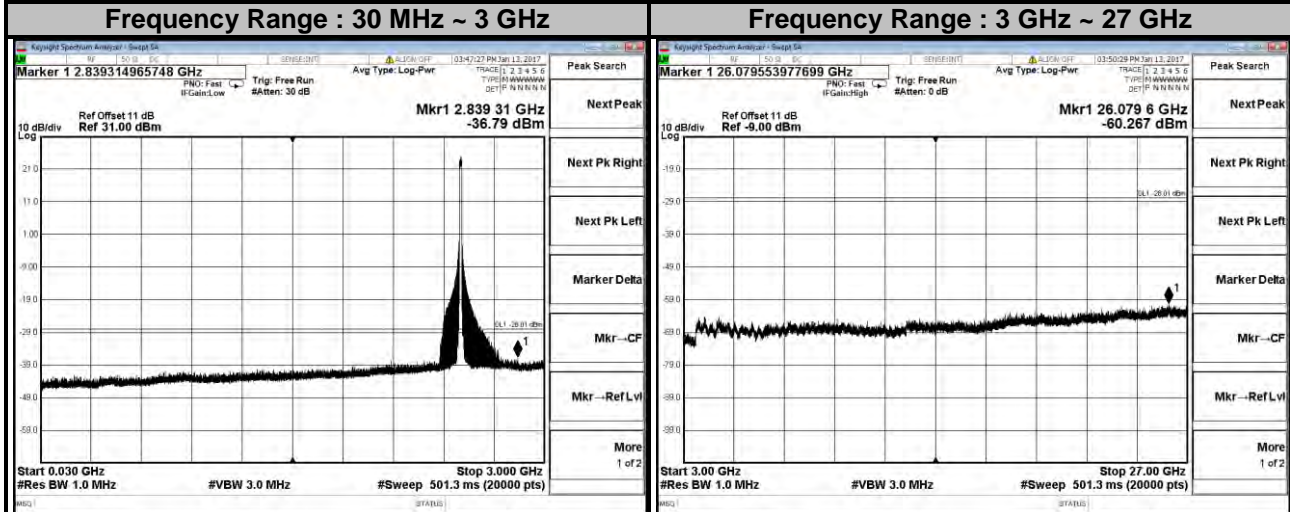

Channel 40620

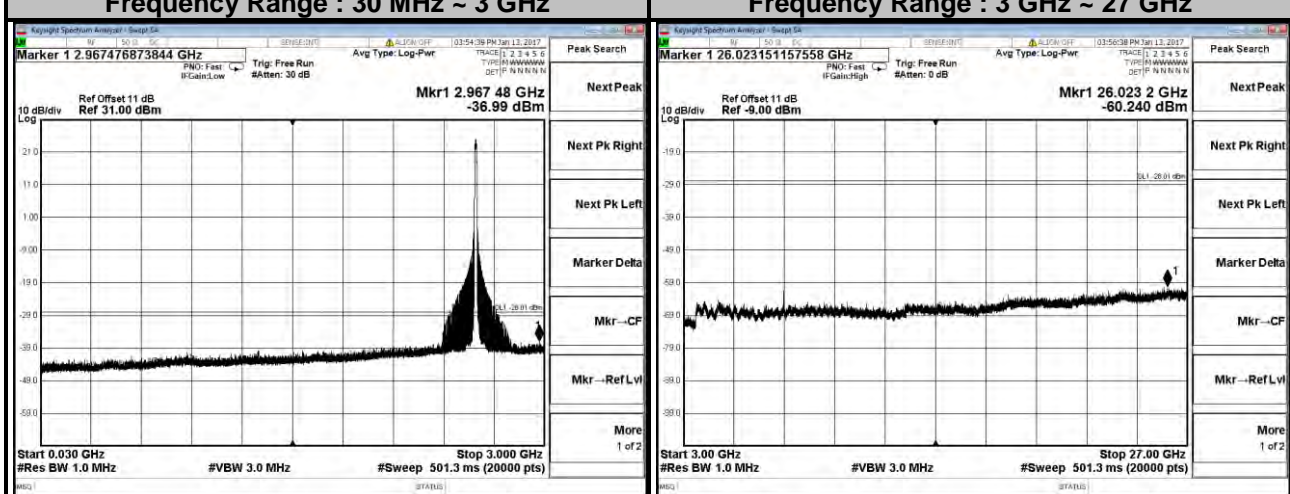

Channel 41515

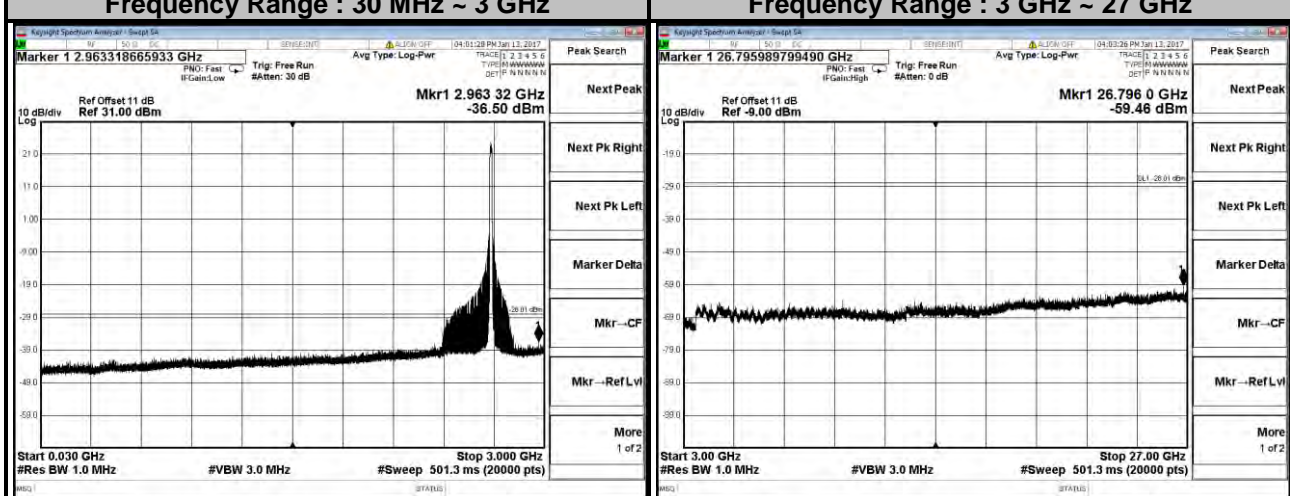

LTE Band 41

Channel Bandwidth: 20 MHz

Low Channel 39750

Frequency (MHz)	Measurement Value	Limit	Margin	Result
2624.13	-35.00	-28.01	-6.99	Pass
26060.40	-60.22	-28.01	-32.21	Pass

Mid Channel 40620

Frequency (MHz)	Measurement Value	Limit	Margin	Result
2763.72	-35.72	-28.01	-7.71	Pass
26440.80	-60.47	-28.01	-32.46	Pass

High Channel 41490

Frequency (MHz)	Measurement Value	Limit	Margin	Result
2926.64	-37.22	-28.01	-9.21	Pass
26432.40	-60.53	-28.01	-32.52	Pass

LTE Band 41
Channel Bandwidth: 20 MHz
Channel 39750

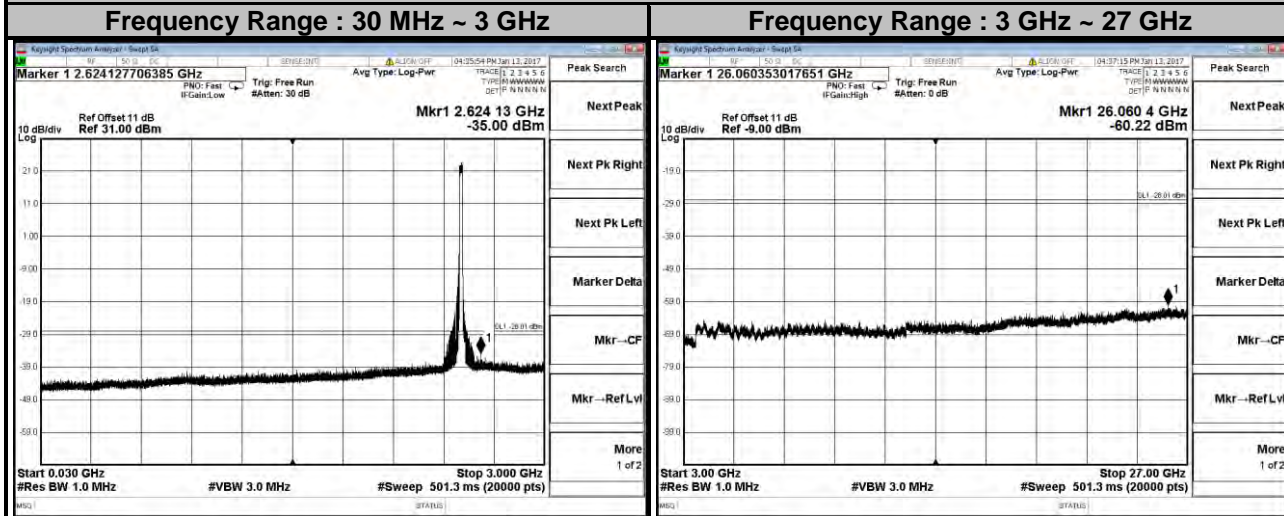

Channel 40620

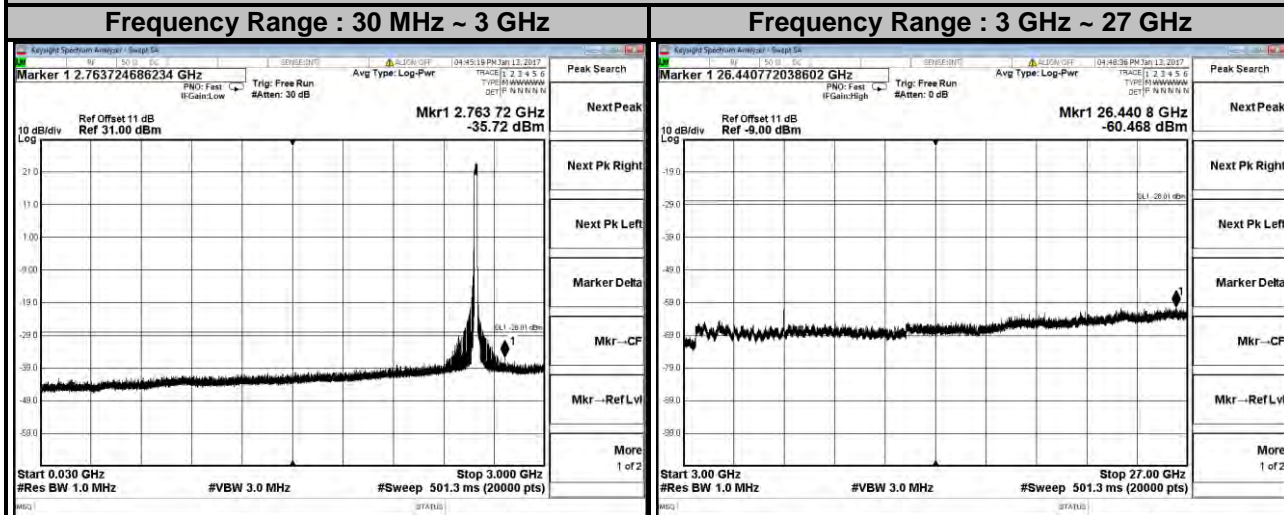

Channel 41490

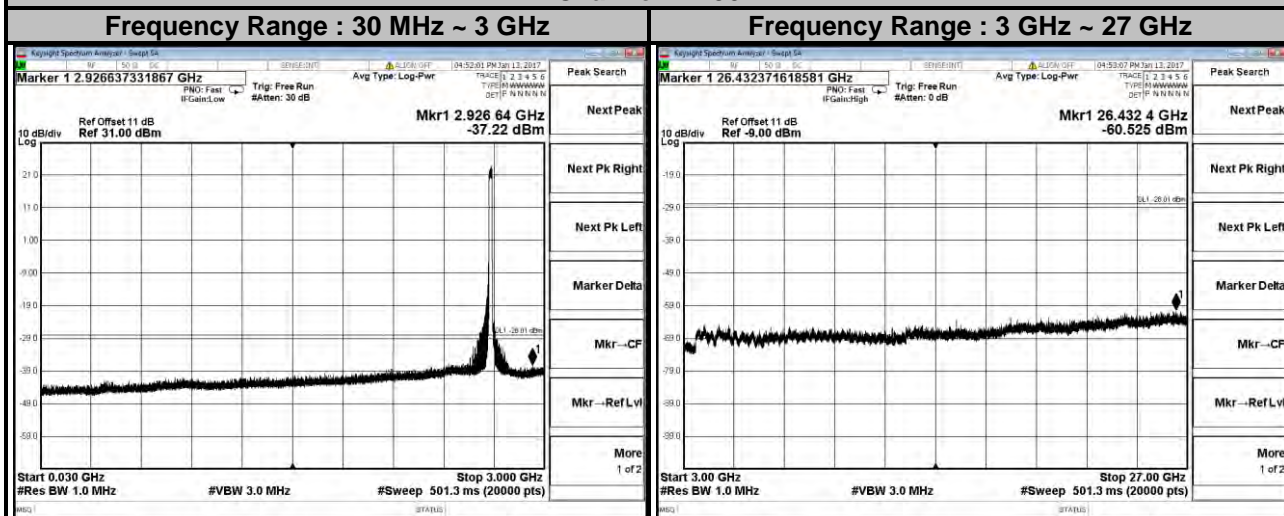

Chain 0

LTE Band 41				
Channel Bandwidth: 20+20 MHz				
Low Channel 39850				
Frequency (MHz)	Measurement Value	Limit	Margin	Result
2732.24	-36.33	-28.01	-8.32	Pass
26690.40	-59.98	-28.01	-31.97	Pass
Mid Channel 40620				
Frequency (MHz)	Measurement Value	Limit	Margin	Result
2754.81	-36.11	-28.01	-8.10	Pass
26107.20	-59.97	-28.01	-31.96	Pass
High Channel 41390				
Frequency (MHz)	Measurement Value	Limit	Margin	Result
2849.71	-36.92	-28.01	-8.91	Pass
26497.20	-59.70	-28.01	-31.69	Pass

LTE Band 41
Channel Bandwidth: 20+20 MHz
Channel 39850

Frequency Range : 30 MHz ~ 3 GHz

Frequency Range : 3 GHz ~ 27 GHz

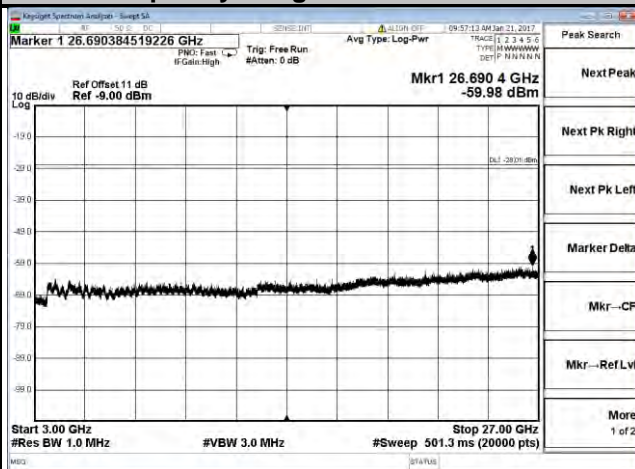
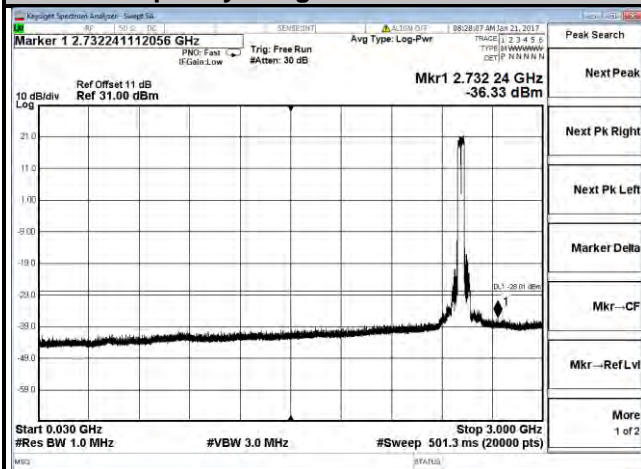

Channel 40620

Frequency Range : 30 MHz ~ 3 GHz

Frequency Range : 3 GHz ~ 27 GHz

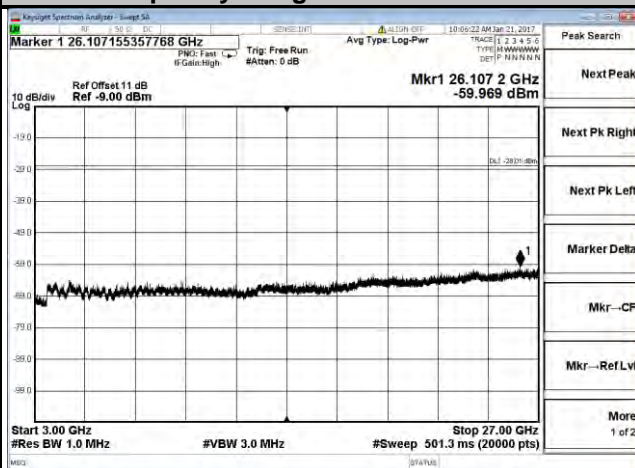
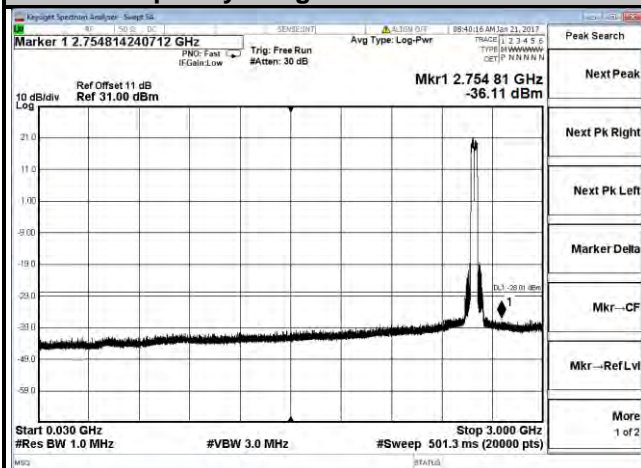

Channel 41390

Frequency Range : 30 MHz ~ 3 GHz

Frequency Range : 3 GHz ~ 27 GHz

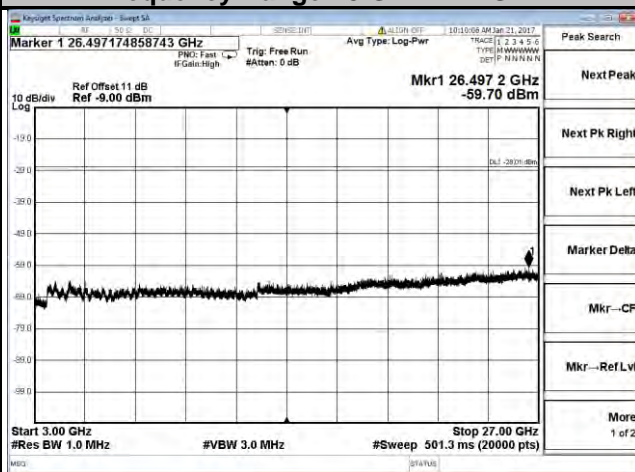
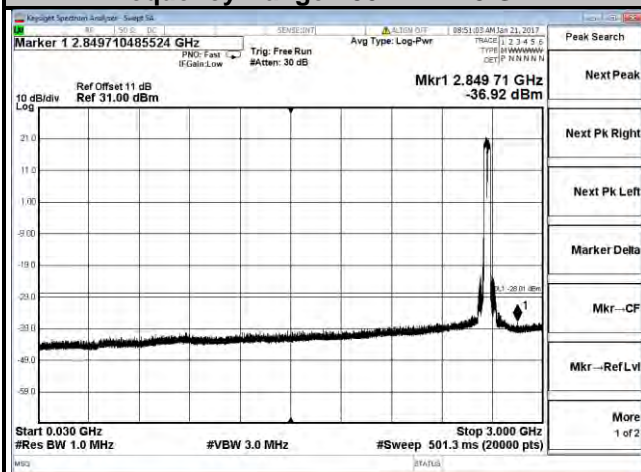

Chain 1

LTE Band 41				
Channel Bandwidth: 20+20 MHz				
Low Channel 39850				
Frequency (MHz)	Measurement Value	Limit	Margin	Result
2698.83	-36.17	-28.01	-8.16	Pass
26029.20	-60.27	-28.01	-32.26	Pass
Mid Channel 40620				
Frequency (MHz)	Measurement Value	Limit	Margin	Result
2813.18	-36.17	-28.01	-8.16	Pass
26118.00	-58.99	-28.01	-30.98	Pass
High Channel 41390				
Frequency (MHz)	Measurement Value	Limit	Margin	Result
2840.21	-36.01	-28.01	-8	Pass
26667.60	-60.47	-28.01	-32.46	Pass

LTE Band 41
Channel Bandwidth: 20+20 MHz
Channel 39850

Frequency Range : 30 MHz ~ 3 GHz

Frequency Range : 3 GHz ~ 27 GHz

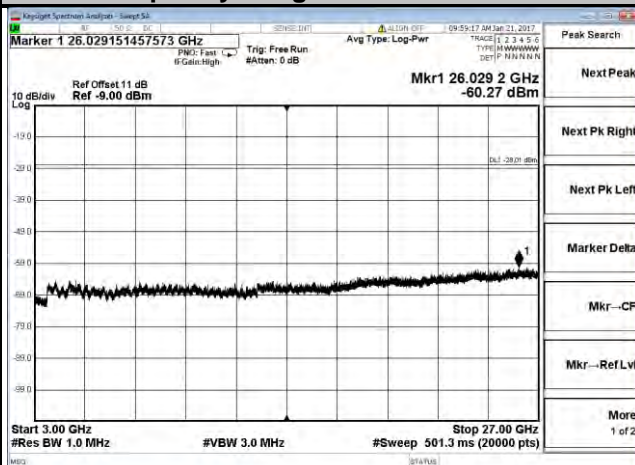
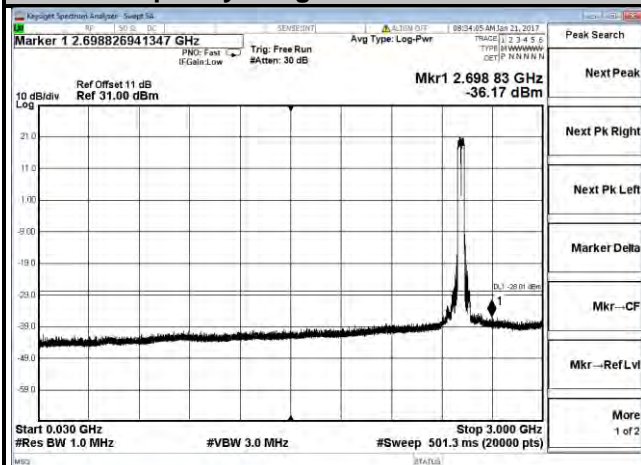

Channel 40620

Frequency Range : 30 MHz ~ 3 GHz

Frequency Range : 3 GHz ~ 27 GHz

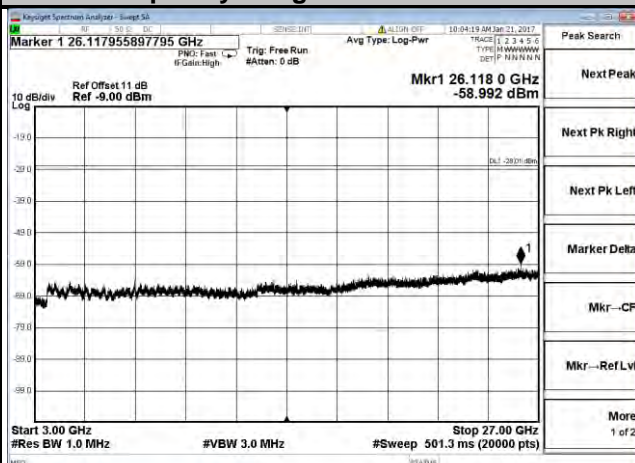
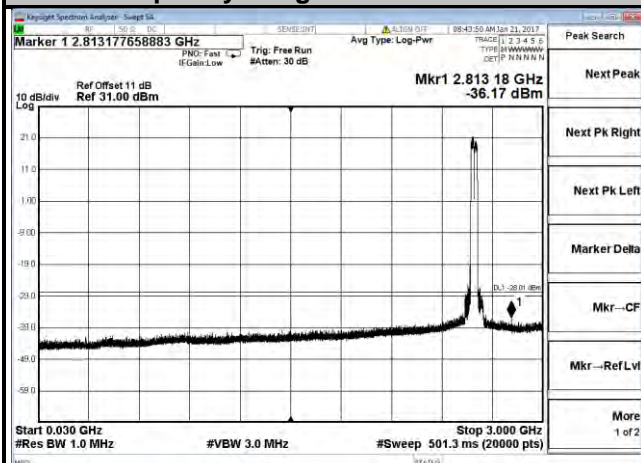

Channel 41390

Frequency Range : 30 MHz ~ 3 GHz

Frequency Range : 3 GHz ~ 27 GHz

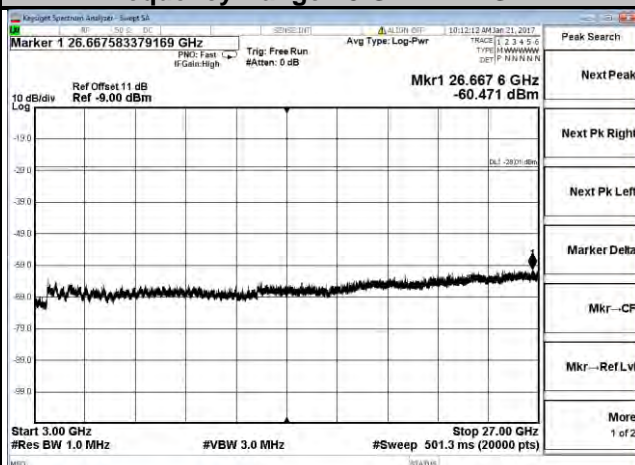
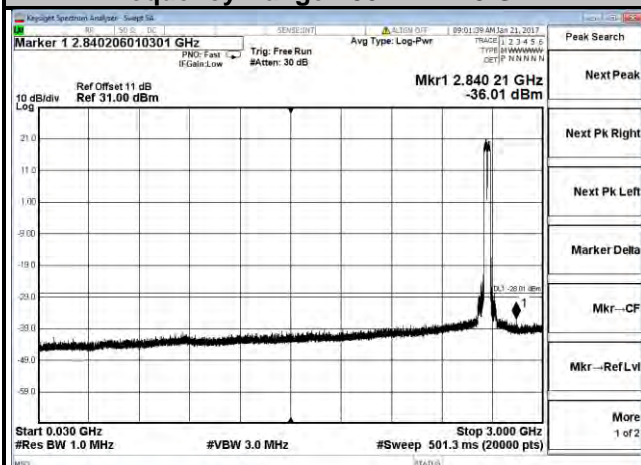

4.7 Radiated Emission Measurement

4.7.1 Limits of Radiated Emission Measurement

The power of any emission outside a licensee's frequency block shall be attenuated below the transmitter power (P) by at least $55 + 10 \log_{10}(P)$ dB. The limit of emission is equal to -25 dBm.

4.7.2 Test Procedure

- Substitution method is used for E.I.R.P measurement. In the semi-anechoic chamber, EUT placed on the 0.8 m height of Turn Table, rotated the table around 360 degrees to search the maximum radiation power and receiver antenna shall be rotated vertical and horizontal polarization and moved height from 1 m to 4 m to find the maximum polar radiated power. The "Read Value" is the spectrum reading the maximum power value.
- The substitution horn antenna is substituted for EUT at the same position and signals generator export the CW signal to the substitution antenna via a TX cable. Rotated the Turn Table and moved receiving antenna to find the maximum radiation power. Adjust output power level of S.G to get a Value of spectrum reading equal to "Read Value" of step a. Record the power level of S.G.
- $EIRP = \text{Output power level of S.G} - \text{TX cable loss} + \text{Antenna gain of substitution horn}$.
- E.R.P power can be calculated form E.I.R.P power by subtracting the gain of dipole, $E.R.P \text{ power} = E.I.P.R \text{ power} - 2.15 \text{ dBi}$.

NOTE: The resolution bandwidth of spectrum analyzer is 1 MHz and the video bandwidth is 3 MHz.

4.7.3 Deviation from Test Standard

No deviation.

4.7.4 Test Setup

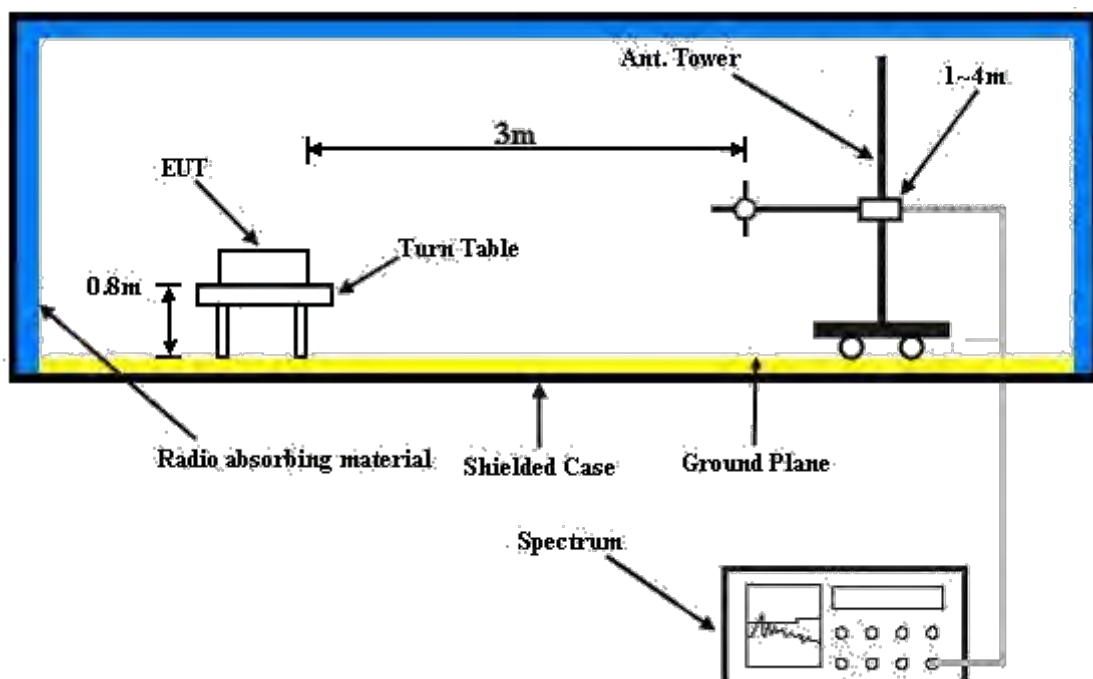

For the actual test configuration, please refer to the attached file (Test Setup Photo).

4.7.5 Test Results

LTE Band 41

Channel Bandwidth: 10 MHz / QPSK

Low Channel

Frequency (MHz)	ERP Final Result (dBm)	Limit(dBm)	Over Limit (dB)	SPA Reading (dBm)	S.G. Power (dBm)	TX Cable loss (dB)	TX Antenna Gain (dBi)	Polarization (H/V)	Result
41.64	-52.50	-25	-27.50	-52.09	-38.4	0.65	-11.3	H	Pass
146.4	-53.00	-25	-28.00	-45.03	-50.95	1.12	1.22	H	Pass
156.1	-53.72	-25	-28.72	-47.78	-52.02	1.15	1.6	H	Pass
279.29	-46.22	-25	-21.22	-39.63	-49.09	1.58	6.6	H	Pass
295.78	-48.05	-25	-23.05	-41.12	-51.06	1.64	6.8	H	Pass
306.45	-52.36	-25	-27.36	-45.45	-55.36	1.66	6.81	H	Pass
5002	-43.23	-25	-18.23	-39.82	-48.08	5.72	10.57	H	Pass
7503	-44.49	-25	-19.49	-49.72	-49.06	6.89	11.46	H	Pass

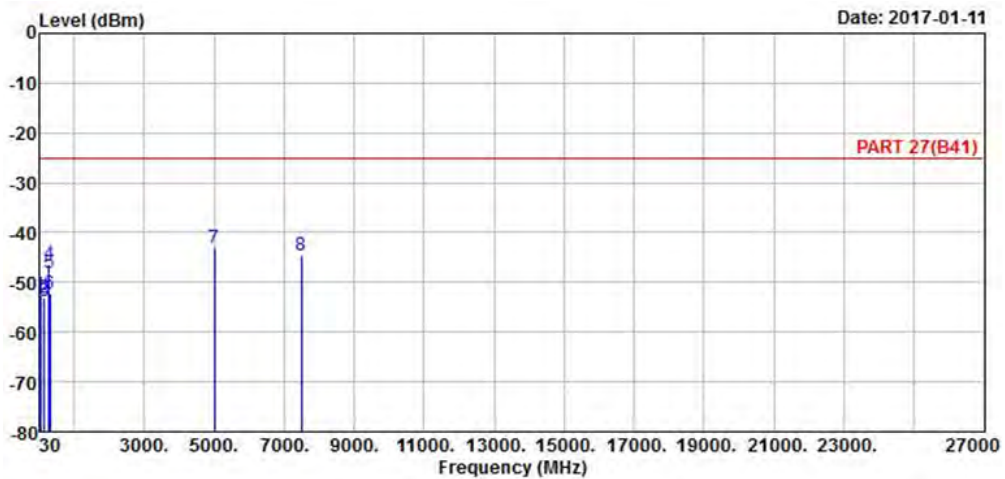

Frequency (MHz)	ERP Final Result (dBm)	Limit(dBm)	Over Limit (dB)	SPA Reading (dBm)	S.G. Power (dBm)	TX Cable loss (dB)	TX Antenna Gain (dBi)	Polarization (H/V)	Result
40.67	-44.38	-25	-19.38	-44.50	-30.28	0.65	-11.3	V	Pass
48.43	-52.23	-25	-27.23	-48.22	-40.58	0.7	-8.8	V	Pass
93.05	-53.38	-25	-28.38	-42.43	-51.26	0.97	1	V	Pass
152.22	-52.84	-25	-27.84	-45.81	-50.79	1.12	1.22	V	Pass
282.2	-53.20	-25	-28.20	-46.55	-56.07	1.58	6.6	V	Pass
299.66	-56.90	-25	-31.90	-49.89	-59.91	1.64	6.8	V	Pass
5002	-40.41	-25	-15.41	-37.00	-45.26	5.72	10.57	V	Pass
7503	-41.18	-25	-16.18	-46.41	-45.75	6.89	11.46	V	Pass

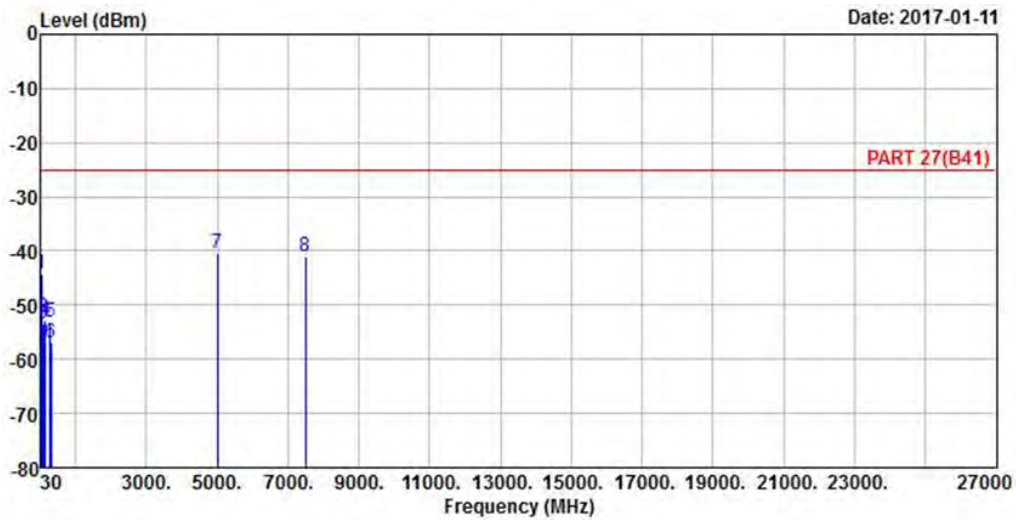

Middle Channel

Frequency (MHz)	ERP Final Result (dBm)	Limit(dBm)	Over Limit (dB)	SPA. Reading (dBm)	S.G. Power (dBm)	TX Cable loss (dB)	TX Antenna Gain (dBi)	Polarization (H/V)	Result
41.64	-53.00	-25	-28.00	-52.59	-38.9	0.65	-11.3	H	Pass
150.28	-51.50	-25	-26.50	-43.92	-49.45	1.12	1.22	H	Pass
160.95	-51.21	-25	-26.21	-46.30	-49.51	1.15	1.6	H	Pass
281.23	-45.30	-25	-20.30	-38.67	-48.17	1.58	6.6	H	Pass
292.87	-46.18	-25	-21.18	-39.31	-49.12	1.61	6.7	H	Pass
309.36	-53.39	-25	-28.39	-46.53	-56.39	1.66	6.81	H	Pass
5186	-51.25	-25	-26.25	-48.52	-56.38	5.72	10.85	H	Pass
7779	-32.67	-25	-7.67	-37.34	-37.22	7.03	11.58	H	Pass

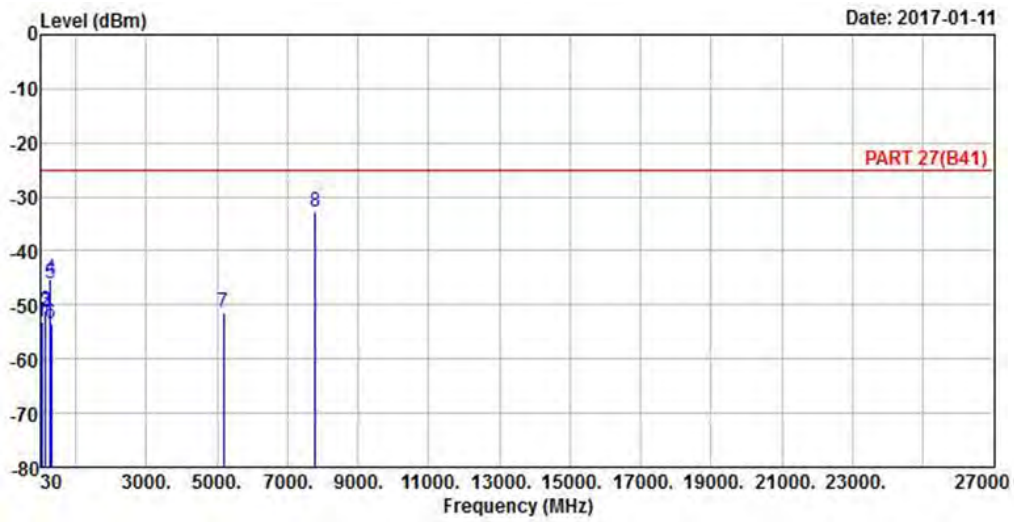

Frequency (MHz)	ERP Final Result (dBm)	Limit(dBm)	Over Limit (dB)	SPA. Reading (dBm)	S.G. Power (dBm)	TX Cable loss (dB)	TX Antenna Gain (dBi)	Polarization (H/V)	Result
40.67	-44.08	-25	-19.08	-44.20	-29.98	0.65	-11.3	V	Pass
46.49	-50.48	-25	-25.48	-47.48	-38.83	0.7	-8.8	V	Pass
146.4	-53.04	-25	-28.04	-45.07	-50.99	1.12	1.22	V	Pass
278.32	-55.33	-25	-30.33	-48.76	-58.2	1.58	6.6	V	Pass
289.96	-53.88	-25	-28.88	-47.07	-56.82	1.61	6.7	V	Pass
299.66	-57.37	-25	-32.37	-50.36	-60.38	1.64	6.8	V	Pass
5186	-49.69	-25	-24.69	-49.96	-54.82	5.72	10.85	V	Pass
7779	-29.43	-25	-4.43	-34.10	-33.98	7.03	11.58	V	Pass

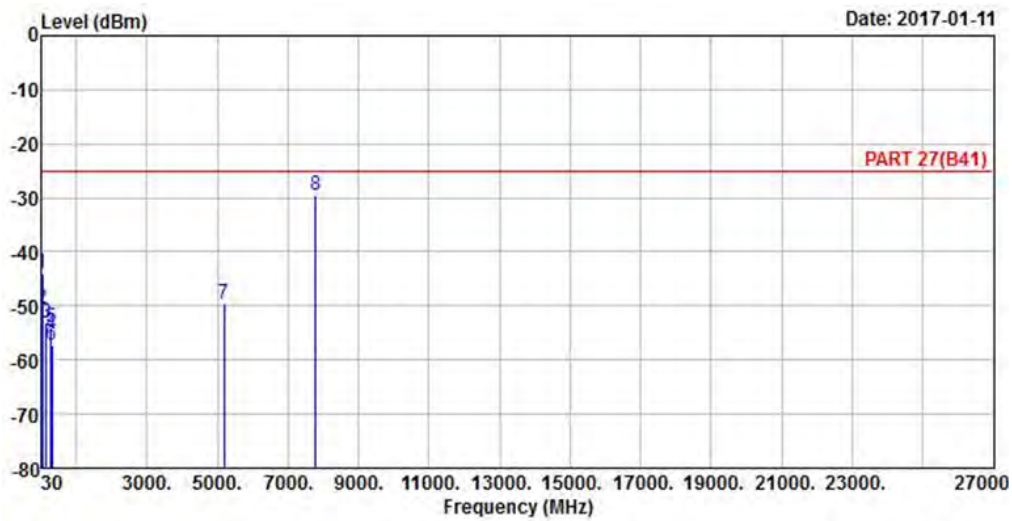

High Channel

Frequency (MHz)	ERP Final Result (dBm)	Limit(dBm)	Over Limit (dB)	SPA. Reading (dBm)	S.G. Power (dBm)	TX Cable loss (dB)	TX Antenna Gain (dBi)	Polarization (H/V)	Result
43.58	-56.56	-25	-31.56	-55.09	-42.46	0.65	-11.3	H	Pass
155.13	-52.18	-25	-27.18	-45.97	-50.48	1.15	1.6	H	Pass
277.35	-48.01	-25	-23.01	-41.46	-51.07	1.55	6.76	H	Pass
284.14	-44.55	-25	-19.55	-37.86	-47.42	1.58	6.6	H	Pass
296.75	-48.03	-25	-23.03	-41.08	-51.04	1.64	6.8	H	Pass
308.39	-53.42	-25	-28.42	-46.54	-56.42	1.66	6.81	H	Pass
5370	-49.57	-25	-24.57	-47.74	-54.65	5.79	10.87	H	Pass
8055	-41.31	-25	-16.31	-46.67	-45.81	7.12	11.62	H	Pass

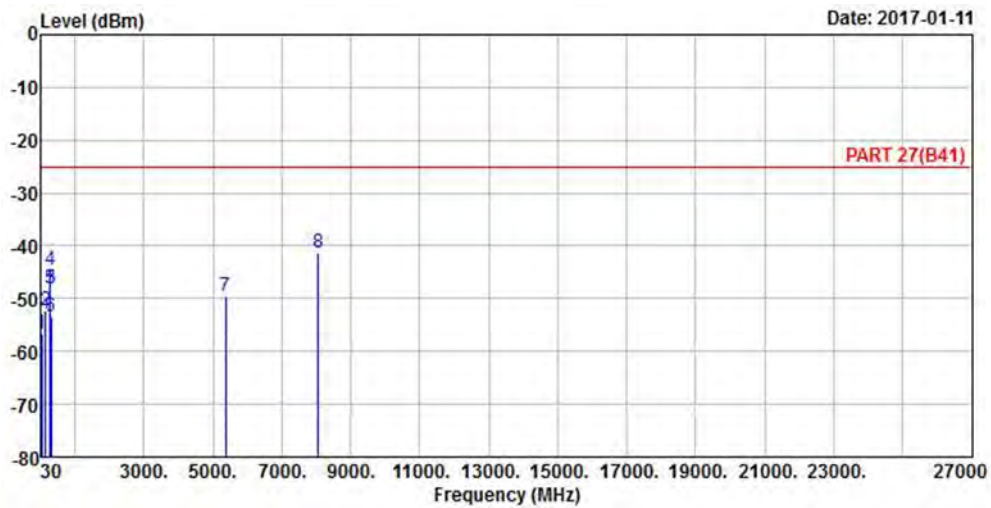

Frequency (MHz)	ERP Final Result (dBm)	Limit(dBm)	Over Limit (dB)	SPA. Reading (dBm)	S.G. Power (dBm)	TX Cable loss (dB)	TX Antenna Gain (dBi)	Polarization (H/V)	Result
43.58	-45.05	-25	-20.05	-43.58	-30.95	0.65	-11.3	V	Pass
93.05	-53.64	-25	-28.64	-42.69	-51.52	0.97	1	V	Pass
152.22	-53.73	-25	-28.73	-46.70	-51.68	1.12	1.22	V	Pass
227.88	-57.73	-25	-32.73	-50.84	-60.91	1.42	6.75	V	Pass
269.59	-57.66	-25	-32.66	-51.27	-60.72	1.55	6.76	V	Pass
288.02	-53.06	-25	-28.06	-46.29	-56	1.61	6.7	V	Pass
5370	-44.48	-25	-19.48	-42.65	-49.56	5.79	10.87	V	Pass
8055	-37.93	-25	-12.93	-43.29	-42.43	7.12	11.62	V	Pass

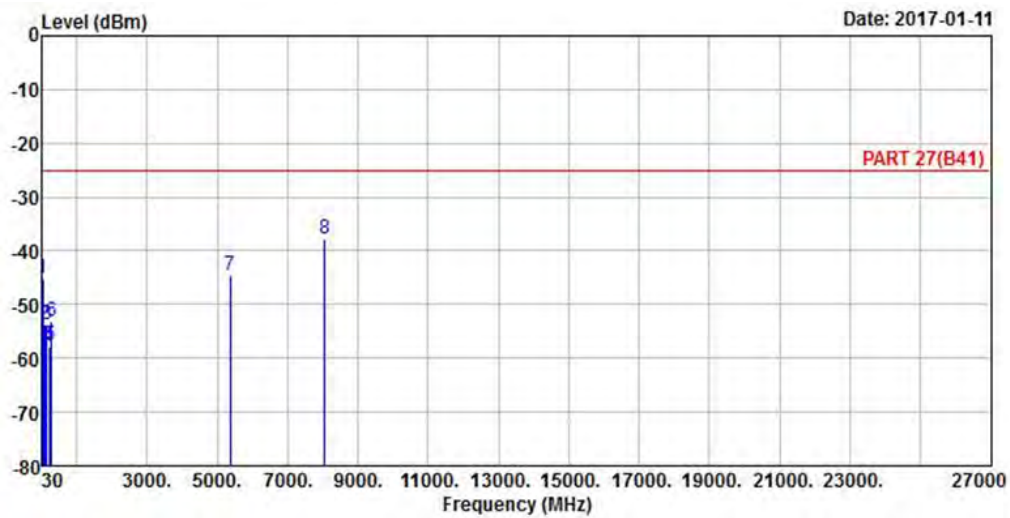

Channel Bandwidth: 15 MHz / QPSK

Low Channel

Frequency (MHz)	ERP Final Result (dBm)	Limit(dBm)	Over Limit (dB)	SPA. Reading (dBm)	S.G. Power (dBm)	TX Cable loss (dB)	TX Antenna Gain (dBi)	Polarization (H/V)	Result
42.61	-53.49	-25	-28.49	-52.55	-39.39	0.65	-11.3	H	Pass
154.16	-50.67	-25	-25.67	-44.19	-48.62	1.12	1.22	H	Pass
172.59	-54.00	-25	-29.00	-47.96	-53.71	1.17	3.03	H	Pass
274.44	-50.09	-25	-25.09	-43.60	-53.15	1.55	6.76	H	Pass
287.05	-45.09	-25	-20.09	-38.34	-48.03	1.61	6.7	H	Pass
298.69	-49.15	-25	-24.15	-42.16	-52.16	1.64	6.8	H	Pass
5007	-46.58	-25	-21.58	-43.26	-51.49	5.69	10.60	H	Pass
7510.5	-43.80	-25	-18.80	-48.95	-48.36	6.92	11.48	H	Pass

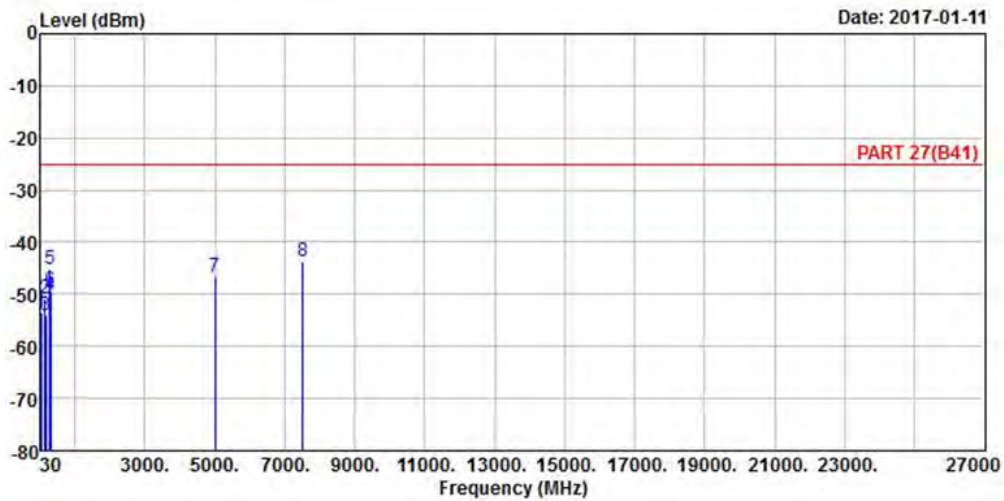

Frequency (MHz)	ERP Final Result (dBm)	Limit(dBm)	Over Limit (dB)	SPA. Reading (dBm)	S.G. Power (dBm)	TX Cable loss (dB)	TX Antenna Gain (dBi)	Polarization (H/V)	Result
39.7	-48.00	-25	-23.00	-48.64	-33.9	0.65	-11.3	V	Pass
45.52	-49.34	-25	-24.34	-46.84	-37.69	0.7	-8.8	V	Pass
94.99	-53.08	-25	-28.08	-42.24	-50.96	0.97	1	V	Pass
149.31	-53.61	-25	-28.61	-45.94	-51.56	1.12	1.22	V	Pass
230.79	-55.71	-25	-30.71	-48.94	-58.89	1.42	6.75	V	Pass
289.96	-54.15	-25	-29.15	-47.34	-57.09	1.61	6.7	V	Pass
5007	-43.36	-25	-18.36	-40.04	-48.27	5.69	10.60	V	Pass
7510.5	-41.72	-25	-16.72	-46.87	-46.28	6.92	11.48	V	Pass

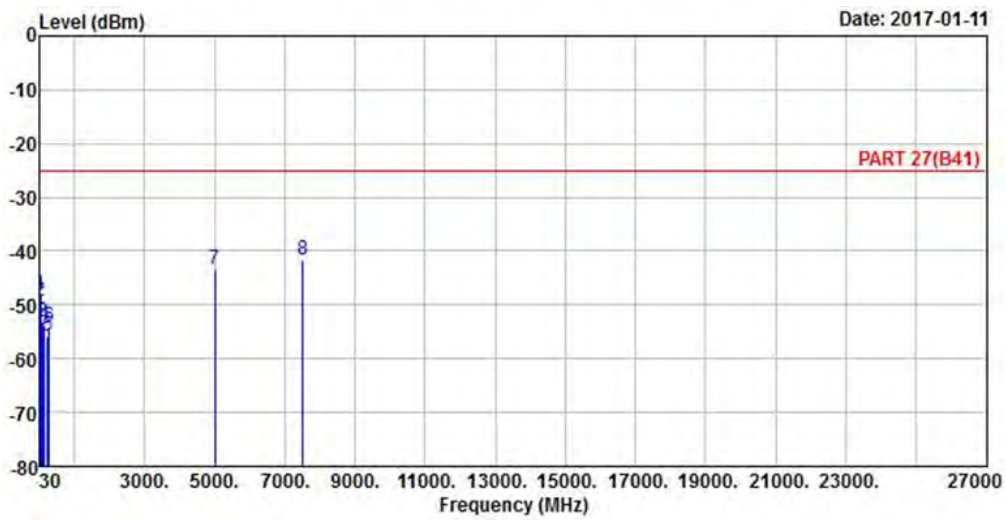

Middle Channel

Frequency (MHz)	ERP Final Result (dBm)	Limit(dBm)	Over Limit (dB)	SPA. Reading (dBm)	S.G. Power (dBm)	TX Cable loss (dB)	TX Antenna Gain (dBi)	Polarization (H/V)	Result
41.64	-52.06	-25	-27.06	-51.65	-37.96	0.65	-11.3	H	Pass
144.46	-51.29	-25	-26.29	-43.13	-48.78	1.16	0.8	H	Pass
154.16	-48.11	-25	-23.11	-41.63	-46.06	1.12	1.22	H	Pass
278.32	-47.77	-25	-22.77	-41.20	-50.64	1.58	6.6	H	Pass
293.84	-47.18	-25	-22.18	-40.29	-50.12	1.61	6.7	H	Pass
304.51	-51.69	-25	-26.69	-44.75	-54.7	1.64	6.8	H	Pass
5186	-50.39	-25	-25.39	-47.66	-55.52	5.72	10.85	H	Pass
7779	-35.76	-25	-10.76	-40.43	-40.31	7.03	11.58	H	Pass

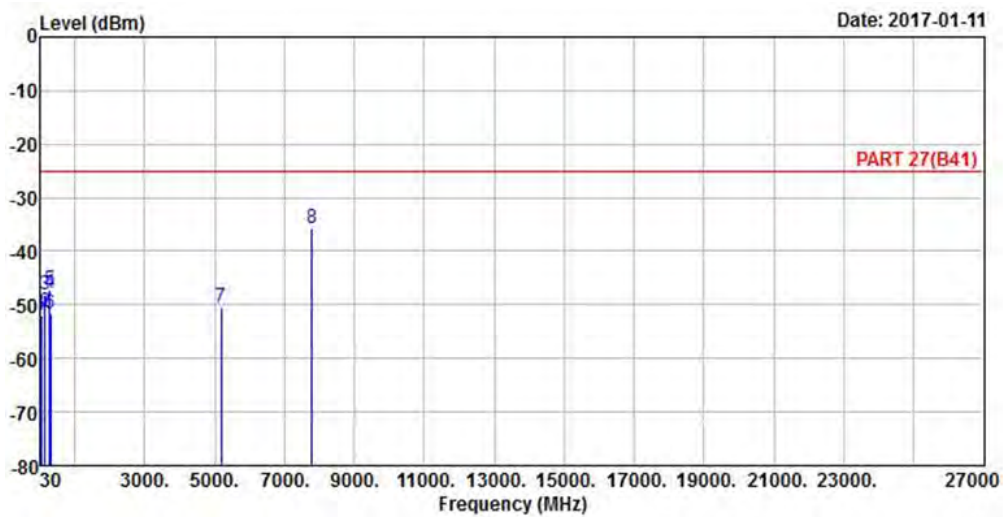

Frequency (MHz)	ERP Final Result (dBm)	Limit(dBm)	Over Limit (dB)	SPA. Reading (dBm)	S.G. Power (dBm)	TX Cable loss (dB)	TX Antenna Gain (dBi)	Polarization (H/V)	Result
39.7	-47.71	-25	-22.71	-47.71	-33.61	0.65	-11.3	V	Pass
45.52	-49.38	-25	-24.38	-46.88	-37.73	0.7	-8.8	V	Pass
94.02	-52.71	-25	-27.71	-41.82	-50.59	0.97	1	V	Pass
149.31	-51.42	-25	-26.42	-43.75	-49.37	1.12	1.22	V	Pass
278.32	-55.50	-25	-30.50	-48.93	-58.37	1.58	6.6	V	Pass
292.87	-55.38	-25	-30.38	-48.51	-58.32	1.61	6.7	V	Pass
5186	-48.80	-25	-23.80	-46.07	-53.93	5.72	10.85	V	Pass
7779	-32.34	-25	-7.34	-37.01	-36.89	7.03	11.58	V	Pass

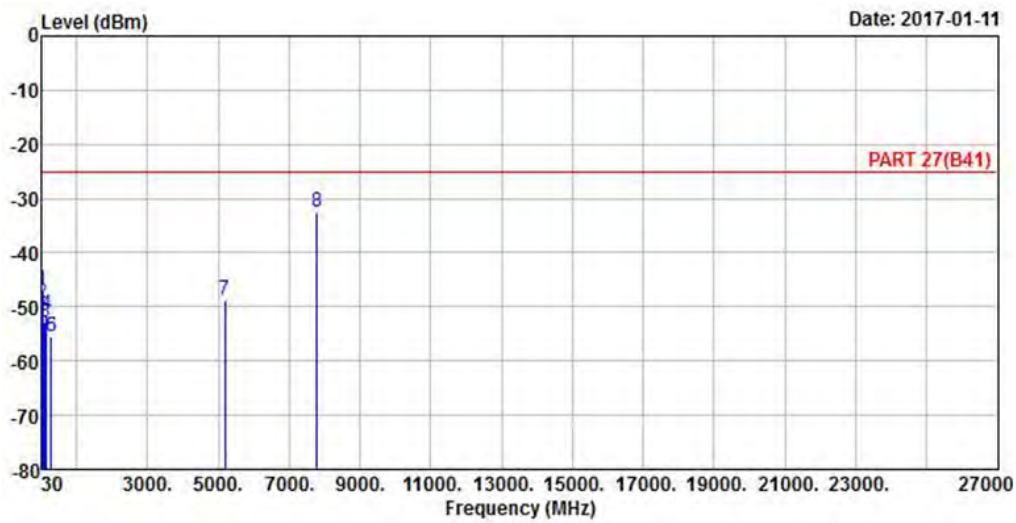

High Channel

Frequency (MHz)	ERP Final Result (dBm)	Limit(dBm)	Over Limit (dB)	SPA. Reading (dBm)	S.G. Power (dBm)	TX Cable loss (dB)	TX Antenna Gain (dBi)	Polarization (H/V)	Result
39.7	-58.44	-25	-33.44	-59.08	-44.34	0.65	-11.3	H	Pass
143.49	-52.91	-25	-27.91	-52.91	-50.4	1.16	0.8	H	Pass
160.95	-50.92	-25	-25.92	-50.92	-49.22	1.15	1.6	H	Pass
179.38	-52.77	-25	-27.77	-52.77	-54	1.22	4.6	H	Pass
273.47	-50.52	-25	-25.52	-50.52	-53.58	1.55	6.76	H	Pass
295.78	-48.15	-25	-23.15	-48.15	-51.16	1.64	6.8	H	Pass
5365	-49.67	-25	-24.67	-47.75	-54.75	5.77	10.85	H	Pass
8047.5	-42.48	-25	-17.48	-47.83	-46.97	7.1	11.59	H	Pass

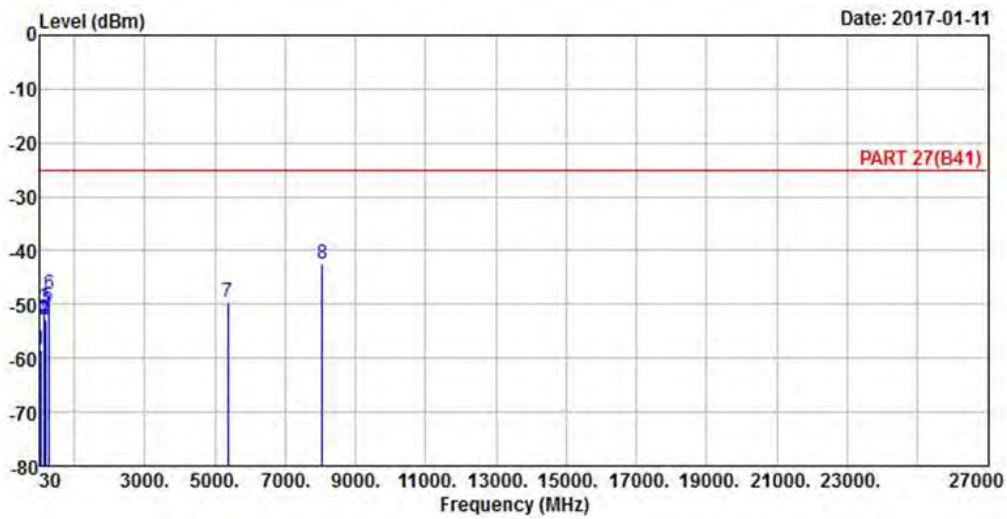

Frequency (MHz)	ERP Final Result (dBm)	Limit(dBm)	Over Limit (dB)	SPA. Reading (dBm)	S.G. Power (dBm)	TX Cable loss (dB)	TX Antenna Gain (dBi)	Polarization (H/V)	Result
43.58	-44.54	-25	-19.54	-43.07	-30.44	0.65	-11.3	V	Pass
95.96	-52.95	-25	-27.95	-42.17	-50.95	1.05	1.2	V	Pass
150.28	-51.26	-25	-26.26	-43.68	-49.21	1.12	1.22	V	Pass
230.79	-59.18	-25	-34.18	-52.41	-62.36	1.42	6.75	V	Pass
286.08	-53.60	-25	-28.60	-46.87	-56.54	1.61	6.7	V	Pass
303.54	-59.11	-25	-34.11	-52.16	-62.12	1.64	6.8	V	Pass
5365	-47.56	-25	-22.56	-45.64	-52.64	5.77	10.85	V	Pass
8047.5	-40.52	-25	-15.52	-45.91	-45.01	7.1	11.59	V	Pass

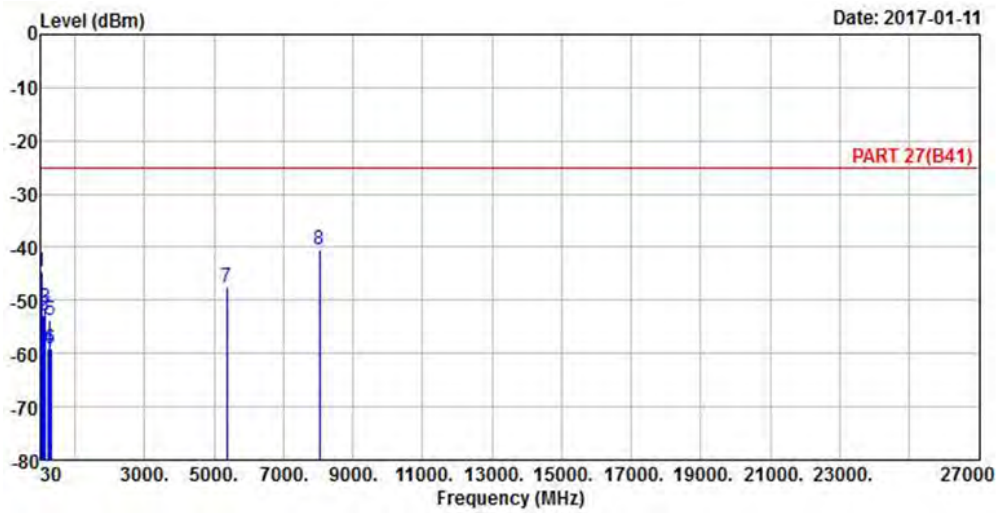

Channel Bandwidth: 20 MHz / QPSK

Low Channel

Frequency (MHz)	ERP Final Result (dBm)	Limit(dBm)	Over Limit (dB)	SPA. Reading (dBm)	S.G. Power (dBm)	TX Cable loss (dB)	TX Antenna Gain (dBi)	Polarization (H/V)	Result
151.25	-49.31	-25	-24.31	-42.01	-47.26	1.12	1.22	H	Pass
154.16	-47.12	-25	-22.12	-40.64	-45.42	1.15	1.6	H	Pass
169.68	-51.04	-25	-26.04	-45.51	-50.75	1.17	3.03	H	Pass
279.29	-47.22	-25	-22.22	-40.63	-50.09	1.58	6.6	H	Pass
290.93	-45.94	-25	-20.94	-39.11	-48.88	1.61	6.7	H	Pass
299.66	-49.80	-25	-24.80	-42.79	-52.81	1.64	6.8	H	Pass
5012	-51.20	-25	-26.20	-47.90	-56.13	5.7	10.63	H	Pass
7518	-45.04	-25	-20.04	-50.20	-49.61	6.94	11.51	H	Pass

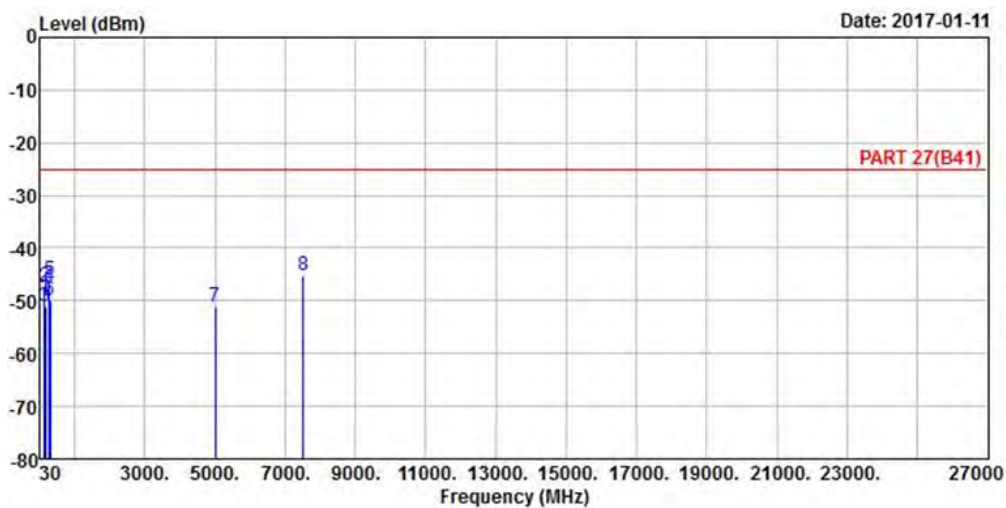

Frequency (MHz)	ERP Final Result (dBm)	Limit(dBm)	Over Limit (dB)	SPA. Reading (dBm)	S.G. Power (dBm)	TX Cable loss (dB)	TX Antenna Gain (dBi)	Polarization (H/V)	Result
40.67	-43.51	-25	-18.51	-43.63	-29.41	0.65	-11.3	V	Pass
91.11	-52.71	-25	-27.71	-41.66	-50.59	0.97	1	V	Pass
154.16	-48.53	-25	-23.53	-42.05	-46.48	1.12	1.22	V	Pass
282.2	-53.76	-25	-28.76	-47.11	-56.63	1.58	6.6	V	Pass
290.93	-54.73	-25	-29.73	-47.90	-57.67	1.61	6.7	V	Pass
299.66	-57.08	-25	-32.08	-50.07	-60.09	1.64	6.8	V	Pass
5012	-50.94	-25	-25.94	-47.64	-55.87	5.7	10.63	V	Pass
7518	-45.08	-25	-20.08	-50.24	-49.65	6.94	11.51	V	Pass

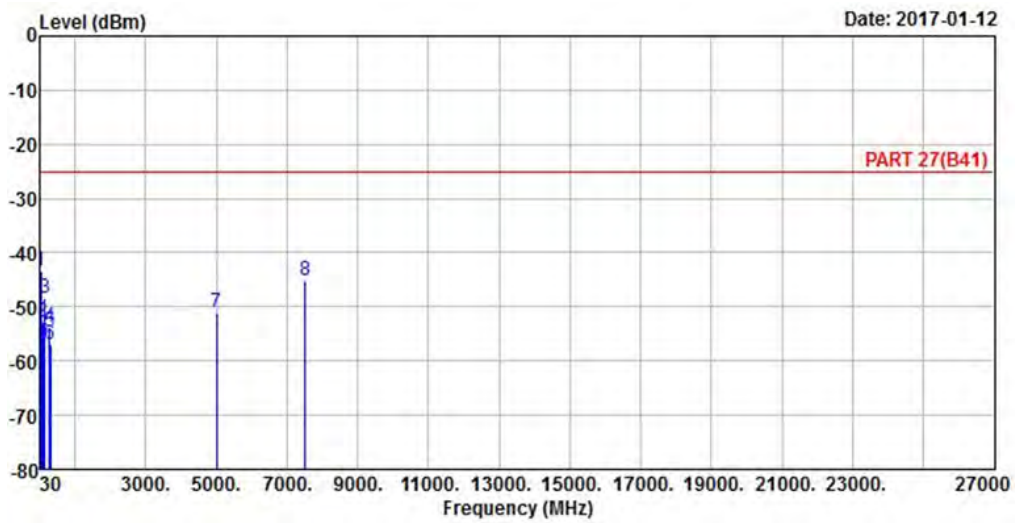

Middle Channel

Frequency (MHz)	ERP Final Result (dBm)	Limit(dBm)	Over Limit (dB)	SPA. Reading (dBm)	S.G. Power (dBm)	TX Cable loss (dB)	TX Antenna Gain (dBi)	Polarization (H/V)	Result
42.61	-53.17	-25	-28.17	-52.23	-39.07	0.65	-11.3	H	Pass
151.25	-48.16	-25	-23.16	-40.86	-46.11	1.12	1.22	H	Pass
159.98	-47.78	-25	-22.78	-42.94	-46.08	1.15	1.6	H	Pass
280.26	-46.29	-25	-21.29	-39.68	-49.16	1.58	6.6	H	Pass
290.93	-45.90	-25	-20.90	-39.07	-48.84	1.61	6.7	H	Pass
306.45	-52.28	-25	-27.28	-45.37	-55.28	1.66	6.81	H	Pass
5186	-50.39	-25	-25.39	-47.66	-55.52	5.72	10.85	H	Pass
7779	-37.65	-25	-12.65	-42.32	-42.20	7.03	11.58	H	Pass

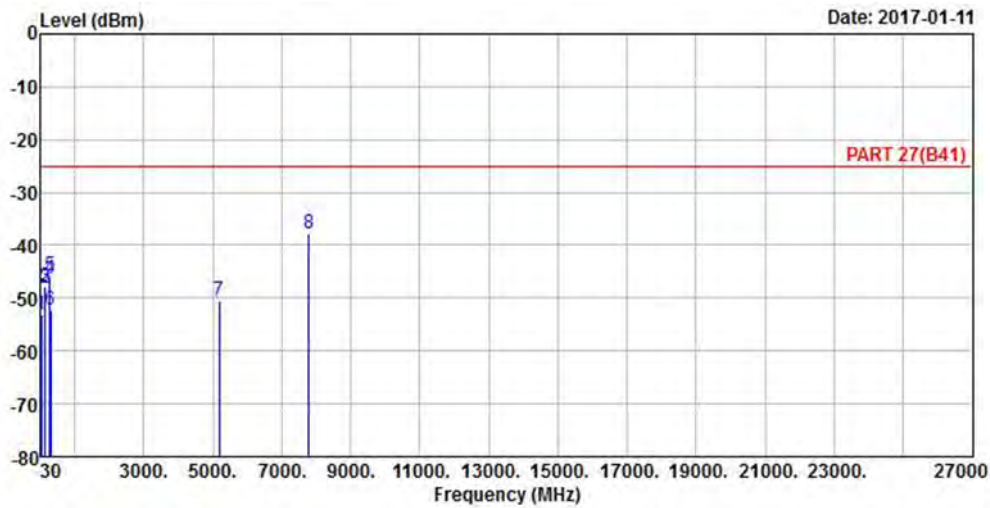

Frequency (MHz)	ERP Final Result (dBm)	Limit(dBm)	Over Limit (dB)	SPA. Reading (dBm)	S.G. Power (dBm)	TX Cable loss (dB)	TX Antenna Gain (dBi)	Polarization (H/V)	Result
41.64	-41.75	-25	-16.75	-41.34	-27.65	0.65	-11.3	V	Pass
92.08	-52.35	-25	-27.35	-41.35	-50.23	0.97	1	V	Pass
152.22	-49.36	-25	-24.36	-42.33	-47.31	1.12	1.22	V	Pass
183.26	-53.19	-25	-28.19	-45.88	-54.42	1.22	4.6	V	Pass
284.14	-53.81	-25	-28.81	-47.12	-56.68	1.58	6.6	V	Pass
292.87	-54.45	-25	-29.45	-47.58	-57.39	1.61	6.7	V	Pass
5186	-50.24	-25	-25.24	-47.51	-55.37	5.72	10.85	V	Pass
7779	-32.81	-25	-7.81	-37.48	-37.36	7.03	11.58	V	Pass

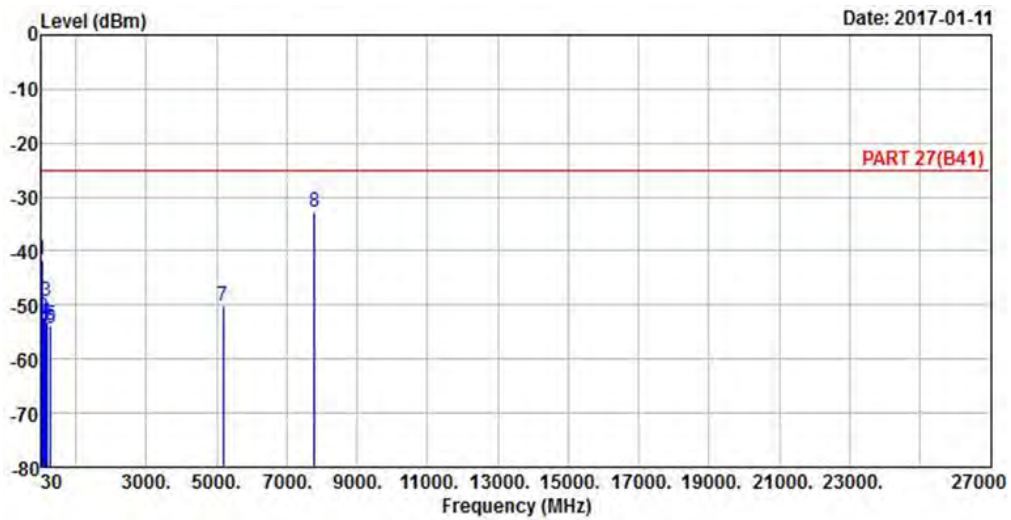

High Channel

Frequency (MHz)	ERP Final Result (dBm)	Limit(dBm)	Over Limit (dB)	SPA. Reading (dBm)	S.G. Power (dBm)	TX Cable loss (dB)	TX Antenna Gain (dBi)	Polarization (H/V)	Result
149.31	-51.41	-25	-26.41	-43.74	-49.36	1.12	1.22	H	Pass
154.16	-47.97	-25	-22.97	-41.49	-46.27	1.15	1.6	H	Pass
174.53	-50.20	-25	-25.20	-43.82	-49.91	1.17	3.03	H	Pass
283.17	-45.54	-25	-20.54	-38.87	-48.41	1.58	6.6	H	Pass
290.93	-45.84	-25	-20.84	-39.01	-48.78	1.61	6.7	H	Pass
297.72	-48.95	-25	-23.95	-41.98	-51.96	1.64	6.8	H	Pass
5360	-50.55	-25	-25.55	-48.63	-55.63	5.74	10.82	H	Pass
8040	-44.69	-25	-19.69	-50.08	-49.18	7.08	11.57	H	Pass

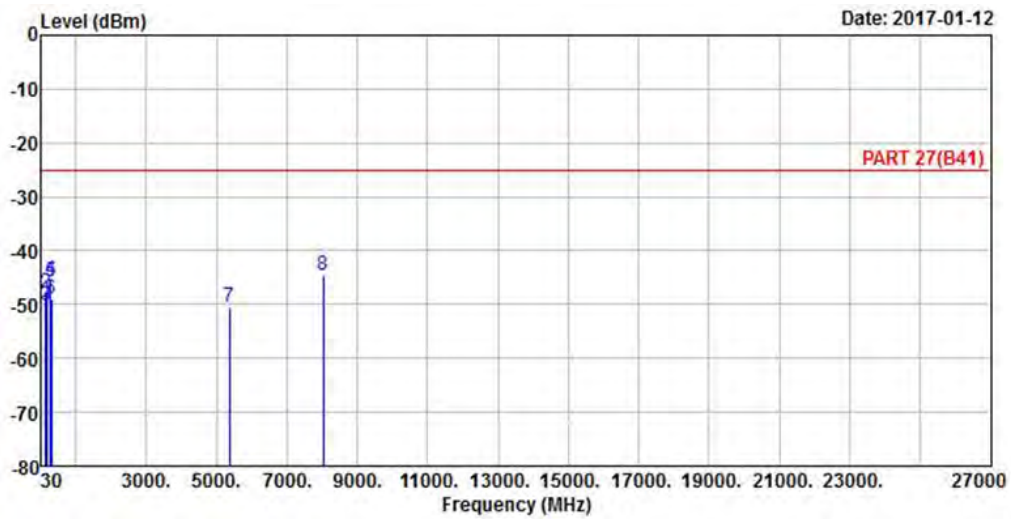

Frequency (MHz)	ERP Final Result (dBm)	Limit(dBm)	Over Limit (dB)	SPA. Reading (dBm)	S.G. Power (dBm)	TX Cable loss (dB)	TX Antenna Gain (dBi)	Polarization (H/V)	Result
41.64	-42.05	-25	-17.05	-41.64	-27.95	0.65	-11.3	V	Pass
44.55	-47.69	-25	-22.69	-45.7	-36.04	0.7	-8.8	V	Pass
152.22	-50.57	-25	-25.57	-43.54	-48.52	1.12	1.22	V	Pass
160.95	-49.87	-25	-24.87	-44.96	-48.17	1.15	1.6	V	Pass
282.2	-53.50	-25	-28.50	-46.85	-56.37	1.58	6.6	V	Pass
296.75	-55.70	-25	-30.70	-48.75	-58.71	1.64	6.8	V	Pass
5360	-46.88	-25	-21.88	-44.96	-51.96	5.74	10.82	V	Pass
8040	-43.61	-25	-18.61	-49.00	-48.10	7.08	11.57	V	Pass

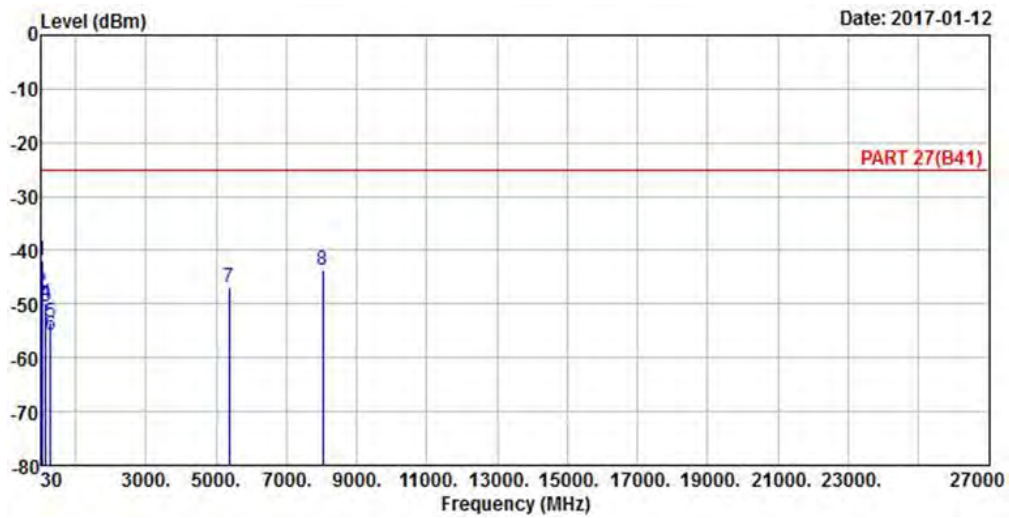

LTE Band 41

Channel Bandwidth: 20+20 MHz / QPSK

Low Channel

Frequency (MHz)	ERP Final Result (dBm)	Limit(dBm)	Over Limit (dB)	SPA. Reading (dBm)	S.G. Power (dBm)	TX Cable loss (dB)	TX Antenna Gain (dBi)	Polarization (H/V)	Result
130.71	-41.18	-25	-16.18	-32.49	-38.69	1.14	0.8	H	Pass
159.6	-38.22	-25	-13.22	-33.38	-36.52	1.15	1.6	H	Pass
199.02	-41.09	-25	-16.09	-33.16	-44.55	1.29	6.9	H	Pass
390.3	-40.13	-25	-15.13	-34.13	-42.99	1.88	6.89	H	Pass
550.6	-46.74	-25	-21.74	-43.93	-48.96	2.18	6.55	H	Pass
660.5	-46.53	-25	-21.53	-45.81	-48.26	2.38	6.26	H	Pass
5032	-51.31	-25	-26.31	-48.05	-56.24	5.7	10.63	H	Pass
7548	-43.72	-25	-18.72	-48.31	-48.29	6.94	11.51	H	Pass

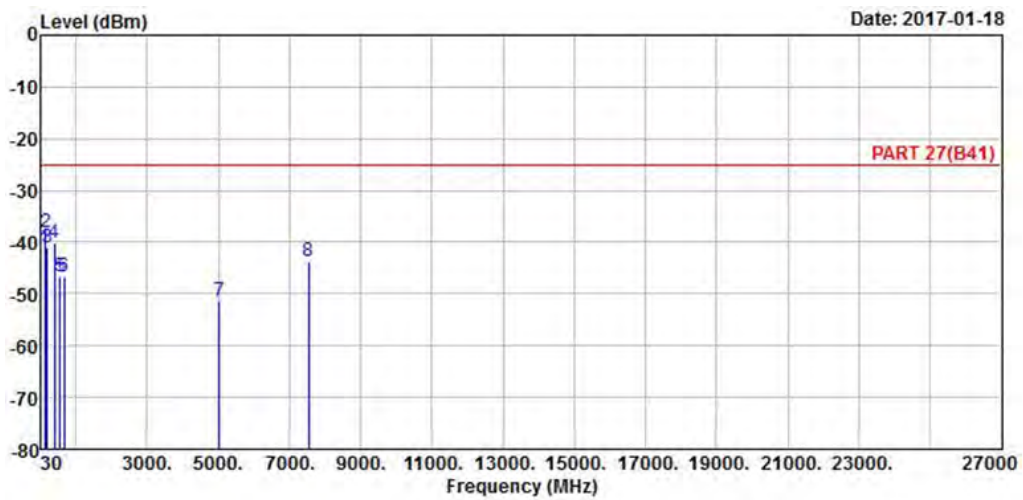

Frequency (MHz)	ERP Final Result (dBm)	Limit(dBm)	Over Limit (dB)	SPA. Reading (dBm)	S.G. Power (dBm)	TX Cable loss (dB)	TX Antenna Gain (dBi)	Polarization (H/V)	Result
38.37	-34.96	-25	-9.96	-35.06	-20.86	0.65	-11.3	V	Pass
130.17	-39.36	-25	-14.36	-30.67	-36.87	1.14	0.8	V	Pass
193.89	-40.67	-25	-15.67	-33.21	-43.01	1.26	5.75	V	Pass
390.3	-41.03	-25	-16.03	-35.03	-43.89	1.88	6.89	V	Pass
490.4	-47.58	-25	-22.58	-42.79	-50.26	2.07	6.9	V	Pass
580	-47.64	-25	-22.64	-46.04	-49.63	2.2	6.34	V	Pass
5032	-50.46	-25	-25.46	-47.20	-55.39	5.7	10.63	V	Pass
7548	-44.14	-25	-19.14	-48.73	-48.71	6.94	11.51	V	Pass

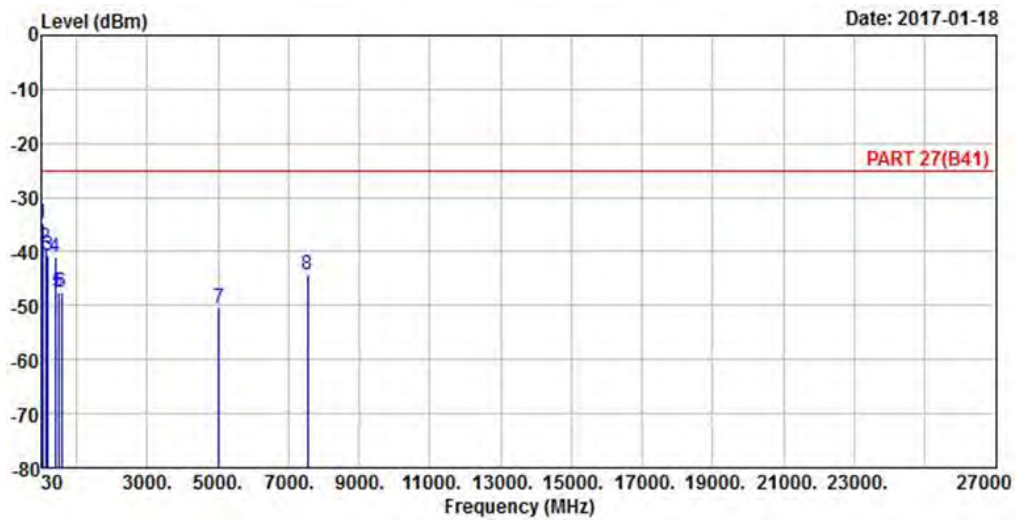

Middle Channel

Frequency (MHz)	ERP Final Result (dBm)	Limit(dBm)	Over Limit (dB)	SPA. Reading (dBm)	S.G. Power (dBm)	TX Cable loss (dB)	TX Antenna Gain (dBi)	Polarization (H/V)	Result
130.17	-38.50	-25	-13.50	-29.81	-36.01	1.14	0.8	H	Pass
160.14	-37.49	-25	-12.49	-32.65	-35.79	1.15	1.6	H	Pass
195.51	-37.36	-25	-12.36	-29.71	-40.82	1.29	6.9	H	Pass
300	-37.20	-25	-12.20	-30.19	-40.21	1.64	6.8	H	Pass
390.3	-40.09	-25	-15.09	-34.09	-42.95	1.88	6.89	H	Pass
549.9	-46.63	-25	-21.63	-43.78	-48.85	2.18	6.55	H	Pass
5186	-51.34	-25	-26.34	-48.57	-56.47	5.72	10.85	H	Pass
7779	-41.51	-25	-16.51	-46.17	-46.06	7.03	11.58	H	Pass

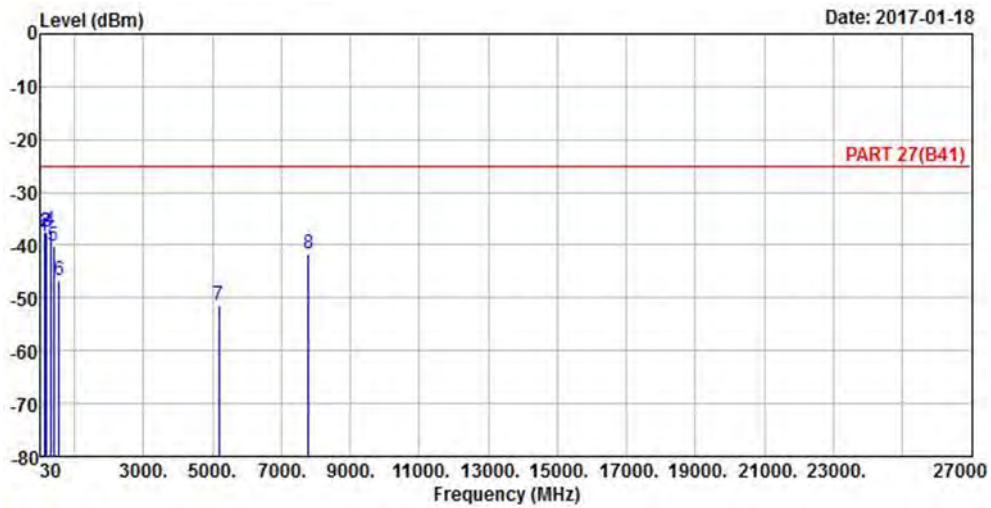

Frequency (MHz)	ERP Final Result (dBm)	Limit(dBm)	Over Limit (dB)	SPA. Reading (dBm)	S.G. Power (dBm)	TX Cable loss (dB)	TX Antenna Gain (dBi)	Polarization (H/V)	Result
39.72	-31.60	-25	-6.60	-32.24	-17.5	0.65	-11.3	V	Pass
130.17	-38.21	-25	-13.21	-29.52	-35.72	1.14	0.8	V	Pass
196.05	-39.94	-25	-14.94	-32.29	-43.4	1.29	6.9	V	Pass
390.3	-41.17	-25	-16.17	-35.17	-44.03	1.88	6.89	V	Pass
580	-46.95	-25	-21.95	-45.35	-48.94	2.2	6.34	V	Pass
740.3	-49.54	-25	-24.54	-50.23	-51.09	2.52	6.22	V	Pass
5186	-50.50	-25	-25.50	-47.73	-55.63	5.72	10.85	V	Pass
7779	-43.40	-25	-18.40	-48.06	-47.95	7.03	11.58	V	Pass

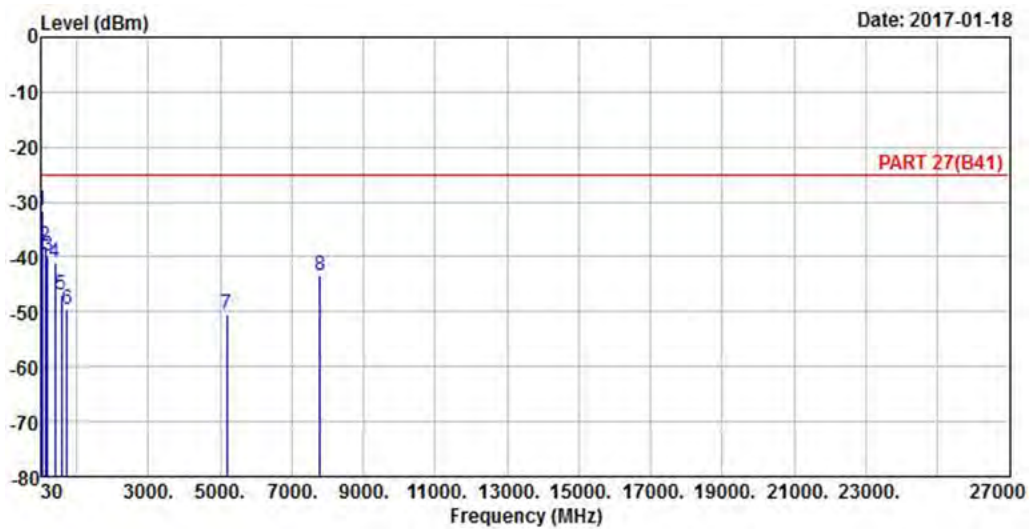

High Channel

Frequency (MHz)	ERP Final Result (dBm)	Limit(dBm)	Over Limit (dB)	SPA. Reading (dBm)	S.G. Power (dBm)	TX Cable loss (dB)	TX Antenna Gain (dBi)	Polarization (H/V)	Result
120.45	-45.44	-25	-20.44	-35.59	-42.93	1.16	0.8	H	Pass
198.48	-39.89	-25	-14.89	-31.96	-43.35	1.29	6.9	H	Pass
230.07	-41.05	-25	-16.05	-34.24	-44.23	1.42	6.75	H	Pass
409.9	-41.47	-25	-16.47	-35.61	-44.29	1.93	6.9	H	Pass
660.5	-46.95	-25	-21.95	-46.23	-48.68	2.38	6.26	H	Pass
740.3	-46.89	-25	-21.89	-47.58	-48.44	2.52	6.22	H	Pass
5340	-49.84	-25	-24.84	-47.82	-54.92	5.74	10.82	H	Pass
8010	-41.43	-25	-16.43	-46.88	-45.92	7.08	11.57	H	Pass

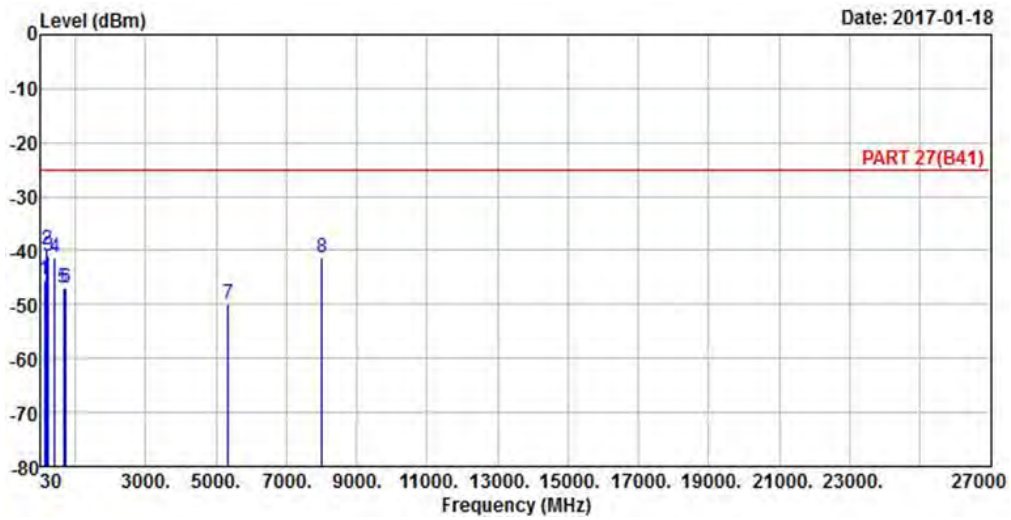

Frequency (MHz)	ERP Final Result (dBm)	Limit(dBm)	Over Limit (dB)	SPA. Reading (dBm)	S.G. Power (dBm)	TX Cable loss (dB)	TX Antenna Gain (dBi)	Polarization (H/V)	Result
38.91	-34.41	-25	-9.41	-34.51	-20.31	0.65	-11.3	V	Pass
130.44	-40.24	-25	-15.24	-31.55	-37.75	1.14	0.8	V	Pass
193.89	-40.49	-25	-15.49	-33.03	-42.83	1.26	5.75	V	Pass
349.7	-40.71	-25	-15.71	-34.47	-43.64	1.77	6.85	V	Pass
491.1	-49.76	-25	-24.76	-44.97	-52.44	2.07	6.9	V	Pass
580.7	-47.02	-25	-22.02	-45.46	-49.01	2.2	6.34	V	Pass
5340	-49.96	-25	-24.96	-47.94	-55.04	5.74	10.82	V	Pass
8010	-43.43	-25	-18.43	-48.88	-47.92	7.08	11.57	V	Pass

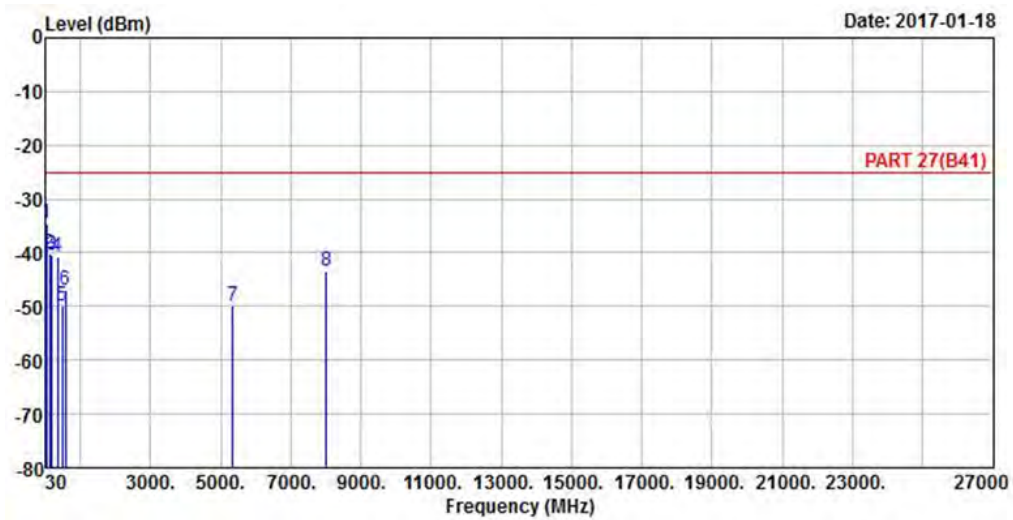

5 Pictures of Test Arrangements

Please refer to the attached file (Test Setup Photo).

Appendix – Information on the Testing Laboratories

We, Bureau Veritas Consumer Products Services (H.K.) Ltd., Taoyuan Branch, were founded in 1988 to provide our best service in EMC, Radio, Telecom and Safety consultation. Our laboratories are accredited and approved according to ISO/IEC 17025.

If you have any comments, please feel free to contact us at the following:

Linko EMC/RF Lab

Tel: 886-2-26052180

Fax: 886-2-26051924

Hsin Chu EMC/RF/Telecom Lab

Tel: 886-3-6668565

Fax: 886-3-6668323

Hwa Ya EMC/RF/Safety

Tel: 886-3-3183232

Fax: 886-3-3270892

Email: service.adt@tw.bureauveritas.com

Web Site: www.bureauveritas-adt.com

The address and road map of all our labs can be found in our web site also.

--- END ---