

EXHIBIT 6**TEST REPORT****SECTION 2.1033(c)(14)**

The data required by Section 2.1046 through 2.1057, inclusive, measured in accordance with the procedures set out in Section 2.1041.

SECTION 2.911 (e)

Technical test data submitted to the TCB and to the Commission shall be signed by the person who performed or supervised the tests. The person signing the test data shall attest to the accuracy of such data. The Commission or TCB may require the person signing the test data to submit a statement showing that they are qualified to make or supervise the required measurements.

Response

Three test reports were attached:

1. RF Test Report on AirScale Micro RRH 2T Band 46 LAA UNII 1/2/3 (AZRB) 1-4 Carriers with BA-AIO3O3T3T3VJX65F-06 & PAS2457-CC1 Antennas (Non-DFS), TR-2019-0082-FCC2-15E RF Non-DFS;
2. RF Test Report on AirScale Micro RRH 2T Band 46 LAA UNII 1/2/3 (AZRB) 4 Carriers (Non-DFS), TR2018-0157-FCC2-15E RF Non-DFS;
3. DFS Test Report on AirScale Micro RRH 2T Band 46 LAA UNII-2 (AZRB) 4 Carriers (DFS), TR2019-0025 FCC 15E DFS.

Global Product Compliance Laboratory
600-700 Mountain Avenue
Room 5B-108
Murray Hill, New Jersey 07974-0636 USA

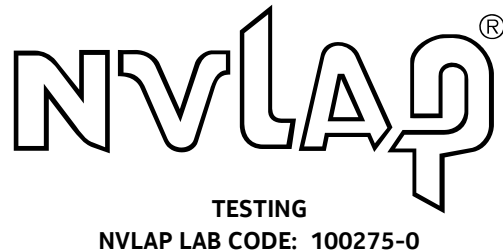

Title 47 Code of Federal Regulations Test Report

Regulation:

FCC Part 2 and 15E

Client:

Nokia Mobile Networks, OY

Product Evaluated:

AirScale Micro RRH 2T Band 46 LAA UNII 1/2/3 (AZRB) 1-4C with BA-AIO3O3T3T3VJX65F-06 & PAS2457-CC1 Antennas (Non-DFS)

Report Number:

TR-2019-0082-FCC2-15E RF Non-DFS

Date Issued:

September 17, 2019

This report shall not be reproduced, in whole or in part without the approval of Nokia Global Product Compliance Laboratory. This report must not be used by the recipient to claim product endorsement by NVLAP or any other agency of the U.S. Government.

Table of Contents

- 1. SYSTEM INFORMATION AND REQUIREMENTS 4**
 - 1.1 INTRODUCTION 5
 - 1.2 PURPOSE AND SCOPE 5
 - 1.3 EUT DETAILS 7
 - 1.4 TEST REQUIREMENTS 10
 - 1.5 STANDARDS & PROCEDURES 10
 - 1.6 EXECUTIVE SUMMARY 12
 - 1.7 TEST CONFIGURATION FOR ALL ANTENNA PORT MEASUREMENTS. 12
 - 1.8 TEST CHANNELS 12
- 2. FCC SECTION 15.407 (A)(1-4) - RF POWER OUTPUT 15**
 - 2.1 RF POWER OUTPUT 15
 - 2.2 MAXIMUM OUTDOOR EIRP 26
- 3. FCC SECTION 15.407(A) (1-3)(5) – PEAK POWER SPECTRUM DENSITY 26**
 - 3.1 PEAK POWER SPECTRUM DENSITY 26
- 4. FCC SECTION 15.407(B) (1-5) - UNWANTED RADIATED OUT-OF-BAND EMISSIONS 38**
 - 4.1 OUT OF BAND EMISSIONS 38
 - 4.2 OUT OF BAND EMISSIONS LIMITS 38
- 5. FCC SECTION 15.407(B) (1-8), 15.205 &15.209 - UNWANTED RADIATED SPURIOUS EMISSIONS 48**
 - 5.1 UNWANTED RADIATED SPURIOUS EMISSIONS 48
 - 5.2 UNWANTED RADIATED SPURIOUS EMISSIONS LIMITS 48
- 6. NVLAP CERTIFICATE OF ACCREDITATION 73**

Revisions

Date	Revision	Section	Change
9/3/2019	0		Initial Release
9/17/2019	r1		Replace Antenna Name Rosenberger with BA-AIO3O3T3T3VJX65F-06 and Laird with PAS24527-CC1; Add a Note for "NA" in the tables of Formal Data on Sections 4.2 and 5.2; Change the unit in the Radiated Emission Limit table in Section 4.2 from "dBm/MHz" to "dBuV/MHz" and change the limit from " Δf " into absolute frequencies.

Nokia Global Product Compliance Laboratories is accredited by the National Voluntary Laboratory Accreditation Program (NVLAP®) for specific services, listed on the Scope of Accreditation, for: Electromagnetic Compatibility and Telecommunications. This laboratory is accredited in accordance with the recognized International Standard ISO/IEC 17025:2005. This accreditation demonstrates technical competence for a defined scope and the operation of a laboratory quality management system (refer to joint ISO-ILAC-IAF Communiqué dated January 2009). NVLAP LAB CODE: 100275-0.

Nokia Global Product Compliance Laboratory represents to the client that the laboratory's accreditation or any of its calibration or test reports in no way constitutes or implies product certification, approval, or endorsement by NVLAP, NIST, or any agency of the federal government.

Prepared By:



Signed: _____ 9/17/2019

Qin Yu
 Compliance Engineer
 q.yu@nokia-bell-labs.com

Approved By:



Signed: _____ 9/17/2019

Raymond Johnson
 Technical Manager
 NVLAP Signatory
 ray.johnson@nokia-bell-labs.com

Reviewed By:



Signed: _____ 9/17/2019

Steve Gordon
 Compliance Engineer
 NVLAP Signatory
 Steve.gordon@nokia-bell-labs.com

1. System Information and Requirements

Equipment Under Test (EUT):	AirScale Micro RRH 2T Band 46 LAA (AZRB) with BA-AIO3O3T3T3VJX65F-06 & PAS2457-CC1 Antennas
FCC ID:	2AD8UAZRBRH1
Serial Number:	AZRB: 1M181319958 (Radiated), 1M181319962 (Conducted)
Hardware Version:	474510A.101
Software Version:	FL18A
Frequency Range:	5170-5250 MHz (UNII-1); 5250-5350 MHz (UNII-2a); 5470-5725 MHz (UNII-2c); 5735-5835 MHz (UNII-3) E-UTRAN Band 46
Type of Equipment:	Intentional Transceiver
GPCL File Numbers:	2019-0082, 2019-0025, 2019-0119, 2019-0002, 2018-0157, 2018-0240
Applicant & Manufacturer:	Nokia Solutions and Networks, OY 2000 W. Lucent Lane Naperville, IL 60563 USA
Test Requirement(s):	Title 47 CFR Parts 2 and 15E (Non-DFS)
Test Standards:	<ul style="list-style-type: none"> Title 47 CFR Parts 2 and 15E KDB 789033 D02, General U-NII Test Procedures New Rules, v02r01, December 2017 KDB 662911 D01 Multiple Transmitter Output v02r01 Oct 2013 ANSI C63.10 (2013)
Measurement Procedure(s):	<ul style="list-style-type: none"> FCC-IC-OB - GPCL Power Measurement, Occupied Bandwidth & Modulation Test Procedure 6-20-2019 FCC-IC-SE - GPCL Spurious Emissions Test Procedure 6-20-2019
Test Date(s):	April/August 2019
Type of Application	C2PC
Test Performed By:	Nokia Global Product Compliance Laboratory 600-700 Mountain Ave. P.O. Box 636 Murray Hill, NJ 07974-0636
Product Engineer(s):	Jeff Webb
Lead Engineer:	Qin Yu
Test Engineer (s):	N. Albrecht, J. Yadav, G. Manuel, M. Soli and E Mitchell
Test Results: The AirScale RRH 2T B46 UNII-1/2/3 (AZRB) with BA-AIO3O3T3T3VJX65F-06 & PAS2457-CC1 Antennas, as tested met the above listed requirements. Report copies and other information not contained in this report are held by either the product engineer or in an identified file at the Global Product Compliance Laboratory in New Providence, NJ.	

1.1 Introduction

This Conformity test report applies to the AirScale Micro RRH 2T B46 UNII-1/2/3 (AZRB) with BA-AIO3O3T3T3VJX65F-06 and PAS2457-CC1 Antennas with 1-4C carriers, hereinafter referred to as the Equipment Under Test (EUT). The non-DFS measurement results for AirScale Micro RRH 2T B46 UNII-1/2/3 (AZRB) with other #1-#7 Antennas and 1-4C carriers are covered under TR2018-0033, TR2018-0099, TR2018-0163, TR2018-0233 FCC RF Non-DFS test reports.

1.2 Purpose and Scope

The purpose of this document is to provide the testing data required for qualifying the EUT with the new directional BA-AIO3O3T3T3VJX65F-06 antenna in compliance with FCC Parts 2 and 15E measured in accordance with the procedures set out in Section 2.1033 (c) (14) of the Rules.

AirScale RRH 2T, B46, 1W, is a low power RRH for small cell deployment. It has been FCC certified under FCC ID: 2AD8UAZRBRH1 in UNII-1/2/3 bands for 1x20MHz, 2x20MHz and 3x20MHz carriers with the following antennas:

UNII Antenna Data from Manufacturers

Ant No	Model Name	Antenna Type/ Size (mm)	Frequency (MHz)	Tx/Rx Port	Max Gain (dBi)	
					Port 1	Port 2
1	AARC	Directional 295(L) × 270(W) × 30(D)	5150 ~ 5850	Tx/Rx 1/2	4.91	4.91
2	FA2RC	Directional 160(L) × 110(W) × 44(D)	5150 ~ 5850	Tx/Rx 1/2	6.0	6.0
3	VVSSP- 360S-F	Omni-Directional 600(L) × 100(R)	5150 ~ 5925	Tx/Rx 1/2	5.1	5.1
4	GQ2410- 06645	Omni-Directional 634(L) × 127.5(R)	5150 ~ 5925	Tx/Rx 1/2	5.9	5.9
5	2205	Directional 198(W) × 24.5(D) × 198(H)	5150 ~ 5925	Tx/Rx 1/2	9.5	9.5
6	GO4806- 06664	Omni-Directional, 1219(L) × 52(D)	5150 ~ 5925	Tx/Rx 1/2	6.0	6.0
7	FA2RA	Omni-Directional , 235(L) × 51(D)	5150 ~ 5850	Tx/Rx 1/2	7.5	7.5

UNII-1/2/3 Antennas Tested In the Previous Filings (with the Highest Gain of Each Type)

Antenna No	Model Name	Antenna Type	Frequency (MHz)	Max Gain (dBi)		Notes
				Port 1	Port 2	
4	GQ2410-06645	Omni-Directional	5150 ~ 5925	5.9	5.9	Original Filing
5	2205	Directional	5150 ~ 5925	9.5	9.5	
6	GO4806-06664	Omni-Directional	5150 ~ 5925	6.0	6.0	C2PC
7	FA2RA	Omni-Directional	5150 ~ 5850	7.5	7.5	C2PC

The BA-AIO3O3T3T3VJX65F-06 antenna is a new directional antenna with 9.5dBi gain. A 9.5dBi directional antenna has previously been authorized (#5). However, this antenna will be used and installed through 1:3 splitter and feedline (cable) of a few feet which has a total path loss no more than 6.5dB. The pathloss effectively reduces the antenna gain or the EUT's RF output power, i.e., the EUT's EIRP power, since the

maximum conducted power of AZRB is capped at 1W. Two transmitting signals from Tx1 and Tx2 are fed into two 1:3 splitters through feedlines and then are connected to the antennas. Other unused ports are terminated.

Similarly, the PAS2457-CC1 antenna is also a new directional antenna with 10.5dBi gain. This antenna is installed with a 33 ft cable from the AZRB to a splitter and then a 2 ft cable from the splitter to the antenna where the pathloss is no more than 8.0dB which effectively reduces the EUT’s EIRP power. The EUT with the PAS2457-CC1 antenna and BA-AIO3O3T3T3VJX65F-06 antenna will have a maximum effective EIRP of 32.4dBm and 33.4dBm, respectively, below the limit allowed by the FCC rules.

BA-AIO3O3T3T3VJX65F-06 & PAS2457-CC1 Antenna Data from Manufacturers

Ant No	Model Name	Antenna Type/ Size (mm)	Frequency (MHz)	Tx/Rx Port	Max Gain (dBi)	
					Port 1	Port 2
8	BA-AIO3O3T3T3VJX65F-06	Directional 608(L) × 350(W) × 138(D)	5150 ~ 5925	Tx/Rx 1/2	9.5	9.5
9	PAS2457-CC1	Directional 545(L) × 138(W) × 38(D)	5150 ~ 5925	Tx/Rx 1/2	10.5	10.5

**Antenna Gains in UNII-1 Band
 in Elevation Angles 30° above the Horizontal Plane for Outdoor EUT**

Antenna No	Model	Antenna Type	Max Gain in Elevation Angle 30° above Horizont (dBi)
1	AARC	Directional	-9.1
2	FA2RC	Directional	-7.0
3	VVSSP-360S-F	Omni-Directional	-9.5
4	GQ2410-06645	Omni-Directional	-11.0
5	2205	Directional	-7.0
6	GO4806-06664	Omni-Directional	-9.0
7	FA2RC	Omni-Directional	-8.0
8	BA-AIO3O3T3T3VJX65F-06	Directional	-4.3
9	PAS2457-CC1	Directional	0.0

Therefore, a Class II permissive change is needed for BA-AIO3O3T3T3VJX65F-06 & PAS2457-CC1 antennas due to new configuration. The non-DFS testing will be mainly performed with BA-AIO3O3T3T3VJX65F-06 antenna.

The conducted power level at 10dBm per port and 13dBm per unit was evaluated for the TPC feature of #5 Galtronics antenna 2205 (9.5dBi) in the original filing, which is 22.5dBm EIRP, 1.5dB lower than the 24dBm EIRP requirement. Therefore, no TPC testing is needed for BA-AIO3O3T3T3VJX65F-06 or PAS2457-CC1 antennas which have more than 6dBi additional cable loss. The EUT can generate much lower power at BA-AIO3O3T3T3VJX65F-06 and PAS2457-CC1 antenna ports with splitter/cable than other antennas without splitter/cable.

1.3 EUT Details

1.3.1 Specifications

Specification Items	Description	
Radio Access Technology	LAA LTE-TDD	
Operation Mode	Master Device, Point to Multipoint	
Modulation Type(s)	QPSK, 16QAM, 64QAM, 256QAM	
Operation Frequency Range	E-UTRAN Band 46: 5170-5250 MHz (UNII-1); 5250-5350 MHz (UNII-2a); 5470-5725 MHz (UNII-2c); 5735-5835 MHz (UNII-3)	
Tx and Rx Signal Bandwidths	5/10/15/20MHz	
Number of Tx and Rx Paths	2TX/2RX	
MIMO	Yes	
Max Conducted RF Power (Splitters and feedlines of BA-AIO3O3T3T3VJX65F-06 and PAS2457-CC1 Ants are included)	5170-5250 MHz (UNII-1)	BA-AIO3O3T3T3VJX65F-06 Ant (9.5dBi Gain): 1x20MHz-3x20MHz: 30dBm total at AZRB ports and 23.9dBm total at antenna ports; 4x20MHz: 29dBm total at AZRB ports and 22.9dBm total at antenna ports PAS2457-CC1 Ant (10.5dBi Gain): 1x20MHz-3x20MHz: 30dBm total at AZRB ports and 21.9dBm total at antenna ports; 4x20MHz: 29dBm total at AZRB ports and 20.9dBm total at antenna port
	5250-5350 MHz & 5470-5725 MHz (UNII-2)	BA-AIO3O3T3T3VJX65F-06 Ant (9.5dBi Gain): 1x20MHz: 25.2dBm total at AZRB ports and 19.1dBm total at antenna ports; 2x20MHz-4X20MHz: 26.6dBm total at AZRB ports and 20.5dBm total at antenna port PAS2457-CC1 Ant (10.5dBi Gain): 1x20MHz: 26.2dBm total at AZRB ports and 18.4dBm total at antenna ports 2x20MHz-4X20MHz: 27.2dBm total at AZRB ports and 19.4dBm total at antenna ports
	5735-5835 MHz (UNII-3)	BA-AIO3O3T3T3VJX65F-06 Ant (9.5dBi Gain): 1x20MHz-3x20MHz: 30dBm total at AZRB ports and 23.9dBm total at antenna ports; 4x20MHz: 29dBm total at AZRB ports and 22.9dBm total at antenna port PAS2457-CC1 Ant (10.5dBi Gain): 1x20MHz-3x20MHz: 30dBm total at AZRB ports and 21.9dBm total at antenna ports; 4x20MHz: 29dBm total at AZRB ports and 20.9dBm total at antenna port
	5170-5250 MHz (UNII-1)	BA-AIO3O3T3T3VJX65F-06 Ant (9.5dBi Gain): 1x20MHz-3x20MHz: 33.4dBm total 4x20MHz: 32.4dBm total

Max Rated EIRP Power		PAS2457-CC1 Ant (10.5dBi Gain): 1x20MHz-3x20MHz: 32.4dBm total 4x20MHz: 31.4dBm		
	5250-5350 MHz & 5470-5725 MHz (UNII-2)	BA-AIO3O3T3T3VJX65F-06 Ant (9.5dBi Gain): 1x20MHz: 28.6dBm total 2x20MHz-4X20MHz: 30dBm total PAS2457-CC1 Ant (10.5dBi Gain): 1x20MHz: 28.9dBm total 2x20MHz-4X20MHz: 29.9dBm total		
	5735-5835 MHz (UNII-3)	BA-AIO3O3T3T3VJX65F-06 Ant (9.5dBi Gain): 1x20MHz-3x20MHz: 33.4dBm total 4x20MHz: 32.4dBm total PAS2457-CC1 Ant (10.5dBi Gain): 1x20MHz-3x20MHz: 32.4dBm total 4x20MHz: 31.4dBm total		
Max OD EIRP at any Elevation Angle above 30° from Horizon	5170-5250 MHz (UNII-1)	≤ 125mW (21 dBm) Outdoor		
Min Conducted Power	50mW (17dBm) per port and 100mW (20dBm) total			
Maxi. Number of Carriers per Port	4x20MHz			
Maxi. Spacing between Carriers in Number of Carriers	N/A			
Deployment Environment	Outdoor			
Environment Temperature Range	-40 °C to +55 °C			
Power Source	DC: -38V to -57V			
	AC (via external AC converter)			
	Minimum	Nominal	Maximum	
	80.0	110.0	276.0	
Antenna	Refer to Section 1.2. No beamforming			

1.3.2 Photographs





1.4 Test Requirements

Each required measurement is listed below:

47 CFR FCC Sections	Description of Tests	Test Required
15.407 (a)(1-4)	Maximum Power Output	Yes
15.407 (a)(1)	Maximum Outdoor EIRP	Yes
15.407 (a)(1-3)(5)	Peak Power Spectrum Density	Yes
15.407 (b)(1-5)(8)	Unwanted Radiated Out-of-Band Emissions	Yes
15.407 (b)(1-8)	Unwanted Radiated Spurious Emissions	Yes

1.5 Standards & Procedures

1.5.1 Standards

- Title 47 Code of Federal Regulations, Federal Communications Commission Part 2.
- Title 47 Code of Federal Regulations, Federal Communications Commission Part 15.

1.5.2 Procedures

1. GPCL FCC-IC-0B and FCC-IC-SE

2. ANSI C63.10 (2013) entitled: “American Nation Standard of Procedures for Compliance Testing of Unlicensed Wireless Devices”, American National Standards Institute, Institute of Electrical and Electronic Engineers, Inc., New York, NY 10017-2394, USA.
3. FCC KDB 789033 D02, General U-NII Test Procedures New Rules, v02r01, December 2017.
4. FCC KDB 662911 D01 Multiple Transmitter Output v02r01 Oct 2013

1.5.3 MEASUREMENT UNCERTAINTY

The results of the calculations to estimate uncertainties for the several test methods and standards are shown in the Table below. These are the worst-case values.

Worst-Case Estimated Measurement Uncertainties

Standard, Method or Procedure	Condition	Frequency MHz	Expanded Uncertainty (k=2)
a. Classical Emissions, (e.g., ANSI C63.4, CISPR 11, 14, 22, etc., using ESHS 30,	Conducted Emissions	0.009 - 30	±3.5 dB
	Radiated Emissions (AR-4 Semi-Anechoic Chamber)	30 MHz – 200MHz H 30 MHz – 200 MHz V 200 MHz – 1000 MHz H 200 MHz – 1000 MHz V 1 GHz - 18 GHz	±5.4 dB ±5.4 dB ±4.7 dB ±4.7 dB ±3.3 dB

Antenna Port Test	Signal Bandwidth	Frequency Range	Expanded Uncertainty (k=2), Amplitude
Occupied Bandwidth, Edge of Band, Conducted Spurious Emissions	10 Hz 100 Hz 10 kHz to 1 MHz 1MHz	9 kHz to 20 MHz 20 MHz to 1 GHz 1 GHz to 10 GHz 10 GHz to 40 GHz:	2.8 dB
RF Power	10 Hz to 20 MHz	50 MHz to 18 GHz	1.4 dB

1.6 Executive Summary

Requirement	Description	Result
47 CFR FCC Parts 2 and 15E		
15.407 (a)(1-4)	Maximum Power Output	COMPLIES
15.407 (a)(1)	Maximum Outdoor EIRP	COMPLIES
15.407 (a)(1-3)(5)	Peak Power Spectrum Density	COMPLIES
15.407 (b)(1-5)(8)	Unwanted Radiated Out-of-Band Emissions	COMPLIES
15.407 (b)(1-8)	Unwanted Radiated Spurious Emissions	COMPLIES

1. **COMPLIES** - Passed all applicable tests.
2. **N/A** – Not Applicable.
3. **NT** – Not Tested.

1.7 Test Configuration for all Antenna Port Measurements.

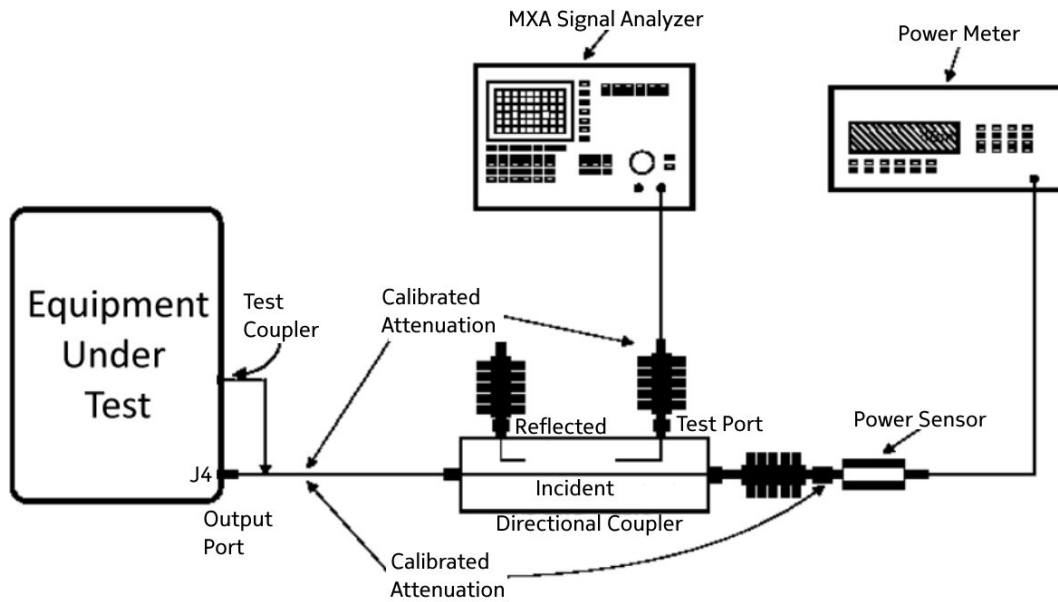

1.8 Test Channels

UNII-1 (5170-5250MHz) Frequency Channel Plan

Channel No.	Freq (MHz)	Bandwidth
36	5180	20MHz
40	5200	
44	5220	
48	5240	
36, 40	5180, 5200	40MHz
44, 48	5220, 5240	60MHz
36, 40, 44	5180, 5200, 5220	
40, 44, 48	5200, 5220, 5240	80 MHz
36, 40, 44, 48	5180, 5200, 5220, 5240	

UNII-2 (5250-5350MHz, 5470-5725MHz) Frequency Channel Plan

Bands	Channel No (Nch)	Freq (MHz)	Ch BW	Frequency Bands
UNII-2a (B46b)	52	5260	20MHz	5250-5350
	56	5280		
	60	5300		
	64	5320		
UNII-2c (B46c)	100	5500	20MHz	5470-5725
	104	5520		
	108	5540		
	112	5560		
	116	5580		
	120	5600		
	124	5620		
	128	5640		
	132	5660		
	136	5680		
	140	5700		
144	5720			
UNII-2a (B46b)	52, 56	5260, 5280	40MHz	5250-5350
	60, 64	5300, 5320		
UNII-2c (B46c)	100, 104	5500, 5520	40MHz	5470-5725
	108, 112	5540, 5560		
	116, 120	5580, 5600		
	124, 128	5620, 5640		
	132, 136	5660, 5680		
	140, 144	5700, 5720		
UNII-2a (B46b)	52, 56, 60	5260, 5280, 5300	60MHz	5250-5350
UNII-2c (B46c)	100, 104, 108	5500, 5520, 5540	60MHz	5470-5725
	112, 116, 120	5560, 5580, 5600		
	124, 128, 132	5620, 5640, 5660		
	136, 140, 144	5680, 5700, 5720		
UNII-2a (B46b)	52, 56, 60, 64	5260, 5280, 5300, 5320	80MHz	5250-5350
UNII-2c (B46c)	100, 104, 108, 112	5500, 5520, 5540, 5560	80MHz	5470-5725
	116, 120, 124, 128	5580, 5600, 5620, 5640		
	132, 136, 140, 144	5660, 5680, 5700, 5720		

5.8GHz UNII-3 (5735 -5835MHz) Frequency Channel Plan

Channel No.	Freq (MHz)	Bandwidth
149	5745	20MHz
153	5765	
157	5785	
161	5805	
165	5825	
149, 153	5745, 5765	40MHz
157, 161	5785, 5805	
161, 165	5805, 5825	
149, 153, 157	5745, 5765, 5785	60MHz
157, 161, 165	5785, 5805, 5825	
149, 153, 157, 161	5745, 5765, 5785, 5805	80MHz
153, 157, 161, 165	5765, 5785, 5805, 5825	

UNII-1 (5170 -5250MHz) Frequency Channels Used for Testing

Channel No.	Freq (MHz)	Bandwidth
36	5180	20MHz
36, 40	5180, 5200	40MHz
36, 40, 44	5180, 5200, 5220	60MHz
36, 40, 44, 48	5180, 5200, 5220, 5240	80 MHz

UNII-2a (5250 -5350MHz) Frequency Channels Used for Testing

Channel No.	Freq (MHz)	Bandwidth
64	5320	20MHz
60, 64	5300, 5320	40MHz
52, 56, 60	5260, 5280, 5300	60MHz
52, 56, 60, 64	5260, 5280, 5300, 5320	80MHz

UNII-2c (5470 -5725MHz) Channels Used for Testing

Channel No.	Freq (MHz)	Bandwidth
100	5500	20MHz
140	5700	
100, 104	5500, 5520	40MHz
100, 104, 108	5500, 5520, 5540	60MHz
100, 104, 108, 112	5500, 5520, 5540, 5560	80MHz

5.8GHz UNII-3 (5735 -5835MHz) Channels Used for Testing

Channel No.	Freq (MHz)	Bandwidth
165	5825	20MHz
161, 165	5805, 5825	40MHz
157, 161, 165	5785, 5805, 5825	60MHz
153, 157, 161, 165	5765, 5785, 5805, 5825	80MHz

2. FCC Section 15.407 (a)(1-4) - RF Power Output

2.1 RF Power Output

This test is a measurement of the total RF power level transmitted at the antenna-transmitting terminal. The product was configured for test as shown in section above and allowed to warm up and stabilize per KDB 789033 D02 and ANSI C63.10.

Transmitter Power Limits at Antenna Ports

Band	Antenna	Max Directional Gain for Total Power (dBi)	Total Power Limit at Ant Port (dBm)
UNII-1	#8	9.5	26.5
UNII-2	#8	9.5	20.5
UNII-3	#8	9.5	26.5
UNII-1	#9	10.5	25.5
UNII-2	#9	10.5	19.5
UNII-3	#9	10.5	25.5

Power measurements were made with an MXA Signal Analyzer.

Maximum Mean RF Power Output for 1x20MHz at Antenna Input Ports (after the Feedlines) of Ant #8 BA-AIO3O3T3T3VJX65F-06 - Power Setting per AZRB port: 27dBm for UNII-1/3 and 22.2dBm for UNII-2

Bands (GHz)	Ch No/ Freq (MHz)	Modulation	Port 1 (dBm)	Port 2 (dBm)	Total Power (dBm)	Power Limit (dBm)	Test Results
UNII-1 (5.17-5.25)	36/5180	Q/16QAM	20.79	20.77	23.79	26.5	Pass
		256QAM	20.89	20.70	23.81	26.5	Pass
UNII-2a (5.25- 5.35)	64/5320	Q/16QAM	16.08	16.07	19.09	20.5	Pass
		256QAM	16.07	16.08	19.09	20.5	Pass
UNII-2c (5.47-5.725)	100/5500	Q/16QAM	16.00	16.05	19.04	20.5	Pass
		256QAM	16.07	16.10	19.10	20.5	Pass
UNII-3 (5.74-5.835)	165/5825	Q/16QAM	20.69	20.71	23.71	26.5	Pass
		256QAM	20.71	20.71	23.72	26.5	Pass

Maximum Mean Combined RF Power Output at AZRB Ports for 5GHz 1x20MHz Carrier (Power Setting per AZRB port: 27dBm for UNII-1/3)

Bands (GHz)	Ch No/ Freq (MHz)	Modulation	Port 1 (dBm)	Port 2 (dBm)	Total Power (dBm)	Pathloss (dB)
UNII-1 (5.17-5.25)	36/5180	Q/16QAM	26.78	26.65	29.73	5.94
		256QAM	26.76	26.78	29.78	5.97
UNII-3 (5.74-5.835)	165/5825	Q/16QAM	26.96	26.88	29.93	6.22
		256QAM	26.99	26.90	29.96	6.24

The maximum output power at the AZRB ports is 30dBm. The pathloss of BA-AIO3O3T3T3VJX65F-06 splitter and feedlines measured with a network analyzer over two ports was 6.48dB (6.65dB and 6.30dB, respectively). The pathloss from the above power measurement is 5.94-6.24dB.

Maximum Mean RF Power Output for 2x20MHz at Antenna Input Ports (after the Feedlines) of Ant #8 BA-AIO3O3T3T3VJX65F-06 - Power Setting per AZRB port: 27dBm for UNII-1/3 & 23.6dBm for UNII-2

Bands (GHz)	Ch No/ Freq (MHz)	Modulation	Port 1 (dBm)	Port 2 (dBm)	Total Power (dBm)	Power Limit (dBm)	Test Results
UNII-1 (5.17-5.25)	36, 40/ 5180, 5200	Q/16QAM	20.76	20.88	23.83	26.5	Pass
		256QAM	20.71	20.82	23.78	26.5	Pass
UNII-2a (5.25-5.35)	56, 60/ 5300, 5320	Q/16QAM	17.44	17.48	20.47	20.5	Pass
		64QAM	17.43	17.48	20.47	20.5	Pass
		256QAM	17.42	17.50	20.47	20.5	Pass
UNII-2c (5.47-5.725)	100, 104/ 5500, 5520	Q/16QAM	17.48	17.48	20.49	20.5	Pass
		64QAM	17.48	17.45	20.48	20.5	Pass
		256QAM	17.49	17.48	20.50	20.5	Pass
UNII-3 (5.74-5.835)	161, 164/ 5805, 5825	Q/16QAM	20.83	20.87	23.86	26.5	Pass
		256QAM	20.84	20.87	23.87	26.5	Pass

Maximum Mean RF Power Output for 3x20MHz at Antenna Input Ports (after the Feedlines) of Ant #8 BA-AIO3O3T3T3VJX65F-06 - Power Setting per AZRB port: 27dBm for UNII-1/3 & 23.6dBm for UNII-2

Bands (GHz)	Ch No/ Freq (MHz)	Modulation	Port 1 (dBm)	Port 2 (dBm)	Total Power (dBm)	Power Limit (dBm)	Test Results
UNII-1 (5.17-5.25)	36, 40, 44/ 5180, 5200, 5220	Q/16QAM	20.89	20.71	23.81	26.5	Pass
		64QAM	20.65	20.90	23.79	26.5	Pass
		256QAM	20.72	20.86	23.80	26.5	Pass
UNII-2a (5.25-5.35)	52, 56, 60/ 5280, 5300, 5320	Q/16QAM	17.44	17.46	20.46	20.5	Pass
		64QAM	17.41	17.42	20.43	20.5	Pass
		256QAM	17.46	17.41	20.45	20.5	Pass
UNII-2c (5.47-5.725)	100, 104, 108/5500, 5520, 5540	Q/16QAM	17.43	17.41	20.43	20.5	Pass
		64QAM	17.49	17.46	20.49	20.5	Pass
		256QAM	17.48	17.47	20.49	20.5	Pass
UNII-3 (5.74-5.835)	157, 161, 165/5785, 5805, 5825	Q/16QAM	20.80	20.88	23.85	26.5	Pass
		64QAM	20.83	20.88	23.87	26.5	Pass
		256QAM	20.79	20.88	23.85	26.5	Pass

Maximum Mean RF Power Output for 4x20MHz at Antenna Input Ports (after the Feedlines) of Ant #8 BA-AIO3O3T3T3VJX65F-06 - Power Setting per AZRB port: 26dBm for UNII-1/3 & 23.6dBm for UNII-2

Bands (GHz)	Ch No/ Freq (MHz)	Modulation	Port 1 (dBm)	Port 2 (dBm)	Total Power (dBm)	Power Limit (dBm)	Test Results
UNII-1 (5.17-5.25)	36, 40, 44, 48/5180 5200, 5220, 5240	Q/16QAM	19.89	19.89	22.90	26.5	Pass
		256QAM	19.81	19.76	22.80	26.5	Pass
UNII-2a (5.25-5.35)	52, 56, 60, 64/ 5260, 5280, 5300, 5320	Q/16QAM	17.44	17.46	20.46	20.5	Pass
		64QAM	17.41	17.46	20.45	20.5	Pass
		256QAM	17.42	17.41	20.43	20.5	Pass
UNII-2c (5.47-5.725)	100, 104, 108, 112/ 5500, 5520, 5540, 5560	Q/16QAM	17.44	17.39	20.43	20.5	Pass
		64QAM	17.50	17.41	20.47	20.5	Pass
		256QAM	17.42	17.50	20.47	20.5	Pass
UNII-3 (5.74-5.835)	153, 157, 161, 165/ 5765, 5785, 5805, 5825	Q/16QAM	19.89	19.87	22.89	26.5	Pass
		256QAM	19.87	19.86	22.88	26.5	Pass

**Maximum Mean RF Power Output for 1x20MHz at Antenna Input Ports (after the Feedlines) of Antenna #9
 PAS2457-CC1 - Power Setting per AZRB port: 27dBm for UNII-1/3 and 23.2dBm for UNII-2**

Bands (GHz)	Ch No/ Freq (MHz)	Modulation	Port 1 (dBm)	Port 2 (dBm)	Total Power (dBm)	Power Limit (dBm)	Test Results
UNII-1 (5.17-5.25)	36/5180	Q/16QAM	18.85	18.92	21.90	25.5	Pass
		256QAM	18.84	18.86	21.86	25.5	Pass
UNII-2a (5.25- 5.35)	64/5320	Q/16QAM	15.32	15.34	18.34	19.5	Pass
		256QAM	15.34	15.30	18.33	19.5	Pass
UNII-2c (5.47-5.725)	100/5500	Q/16QAM	15.35	15.35	18.36	19.5	Pass
		256QAM	15.33	15.35	18.35	19.5	Pass
UNII-3 (5.74-5.835)	165/5825	Q/16QAM	18.84	18.81	21.84	25.5	Pass
		256QAM	18.73	18.77	21.76	25.5	Pass

**Maximum Mean Combined RF Power Output at AZRB Ports for 5GHz 1x20MHz Carrier
 - Power Setting per AZRB port at 27dBm for UNII-1/3**

Bands (GHz)	Ch No/ Freq (MHz)	Modulation	Port 1 (dBm)	Port 2 (dBm)	Total Power (dBm)	Pathloss (dB)
UNII-1 (5.17-5.25)	36/5180	Q/16QAM	26.46	26.39	29.44	7.54
		256QAM	26.42	26.66	29.55	7.69
UNII-3 (5.74-5.835)	165/5825	Q/16QAM	26.68	26.56	29.63	7.79
		256QAM	26.55	26.62	29.60	7.84

The pathloss of PAS2457-CC1 splitter and feedlines measured with a network analyzer was about 7.1-8.0dB. The pathloss from the above power measurement is 7.54-7.84dB.

**Maximum Mean RF Power Output for 2x20MHz at Antenna Input Ports (after the Feedlines) of Antenna #9
 PAS2457-CC1 - Power Setting per AZRB port: 27dBm for UNII-1/3 and 24.2dBm for UNII-2**

Bands (GHz)	Ch No/ Freq (MHz)	Modulation	Port 1 (dBm)	Port 2 (dBm)	Total Power (dBm)	Power Limit (dBm)	Test Results
UNII-1 (5.17-5.25)	36, 40/ 5180, 5200	Q/16QAM	18.82	18.86	21.85	25.5	Pass
		256QAM	18.87	18.80	21.85	25.5	Pass
UNII-2a (5.25-5.35)	60, 64/ 5300, 5320	Q/16QAM	16.32	16.36	19.35	19.5	Pass
		256QAM	16.38	16.35	19.38	19.5	Pass
UNII-2c (5.47-5.725)	100, 104/ 5500, 5520	Q/16QAM	16.34	16.33	19.35	19.5	Pass
		256QAM	16.38	16.38	19.39	19.5	Pass
UNII-3 (5.74-5.835)	161, 164/ 5805, 5825	Q/16QAM	18.80	18.87	21.85	25.5	Pass
		256QAM	18.85	18.86	21.87	25.5	Pass

**Maximum Mean RF Power Output for 4x20MHz at Antenna Input Ports (after the Feedlines) of Antenna #9
 PAS2457-CC1 - Power Setting per AZRB port: 26dBm for UNII-1/3 and 24.2dBm for UNII-2**

Bands (GHz)	Ch No/ Freq (MHz)	Modulation	Port 1 (dBm)	Port 2 (dBm)	Total Power (dBm)	Power Limit (dBm)	Test Results
UNII-1 (5.17-5.25)	36, 40, 44, 48 5180, 5200, 5220, 5240	Q/16QAM	17.81	17.87	20.85	25.5	Pass
		256QAM	17.86	17.87	20.88	25.5	Pass
UNII-2a (5.25-5.35)	52, 56, 60, 64 5260, 5280, 5300, 5320	Q/16QAM	16.35	16.36	19.37	19.5	Pass
		256QAM	16.34	16.33	19.35	19.5	Pass
UNII-2c (5.47-5.725)	100, 104, 108, 112/ 5500, 5520, 5540, 5560	Q/16QAM	16.33	16.39	19.37	19.5	Pass
		256QAM	16.34	16.37	19.37	19.5	Pass
UNII-3 (5.74-5.835)	153, 157, 161, 165/ 5765, 5785, 5805, 5825	Q/16QAM	17.90	17.85	20.89	25.5	Pass
		256QAM	17.87	17.90	20.90	25.5	Pass

**Maximum Total Mean Output Power Measured at Antenna Input Ports for BA-AIO3O3T3T3VJX65F-06
 Antenna #8 with 9.5dBi Gain & 1:3 Splitter & Feedlines - Power Setting per AZRB port: UNII-1/3: 27dBm
 for nx20MHz (n=1-3) & 26dBm for 4x20MHz; UNII-2: 22.2dBm for 1x20MHz and 23.6dBm for mx20MHz
 (m=2-4)**

Bands	Power (dBm) 1x20MHz Carriers	Power (dBm) 2x20MHz & 3x20MHz Carriers	Power (dBm) 4x20MHz Carriers
UNII-1 (5.17-5.25)	23.8	23.8	22.9
UNII-2a (5.25-5.35 GHz)	19.1	20.5	20.5
UNII-2c (5.47-5.725 GHz)	19.1	20.5	20.5
UNII-3 (5.74-5.835)	23.7	23.9	22.9

**Maximum Total Mean Output Power Measured at Antenna Input Ports for PAS2457-CC1 Antenna #9 with
 10.5dBi Gain & 1:3 Splitter & Feedlines - Power Setting per AZRB port: UNII-1/3: 27dBm for nx20MHz
 (n=1-3) & 26dBm for 4x20MHz; UNII-2: 23.2dBm for 1x20MHz and 24.2dBm for mx20MHz (m=2-4)**

Bands	Power (dBm) 1x20MHz Carriers	Power (dBm) 2x20MHz	Power (dBm) 4x20MHz Carriers
UNII-1 (5.17-5.25)	21.9	21.9	20.9
UNII-2a (5.25-5.35 GHz)	18.3	19.4	19.4
UNII-2c (5.47-5.725 GHz)	18.4	19.4	19.4
UNII-3 (5.74-5.835)	21.8	21.9	20.9

2.1.1 Channel RF Power – Plots BA-AIO303T3T3VJX65F-06 Antenna #8

NOTE: Only the plots with the maximum power levels for each band are used in this report. The full suite of raw data resides at the MH, New Jersey location. The RF output power levels displayed below were measured at antenna ports with input feedlines.

Ch_Power_TM3.1a_1C_20MBW_UNII-1_5180_TX1 & TX2 at Antenna Input Port (after the Feedlines) of BA-AIO303T3T3VJX65F-06 #8 Antenna (Total 23.8dBm for Two Ports) - Power Setting: 27dBm per AZRB Port

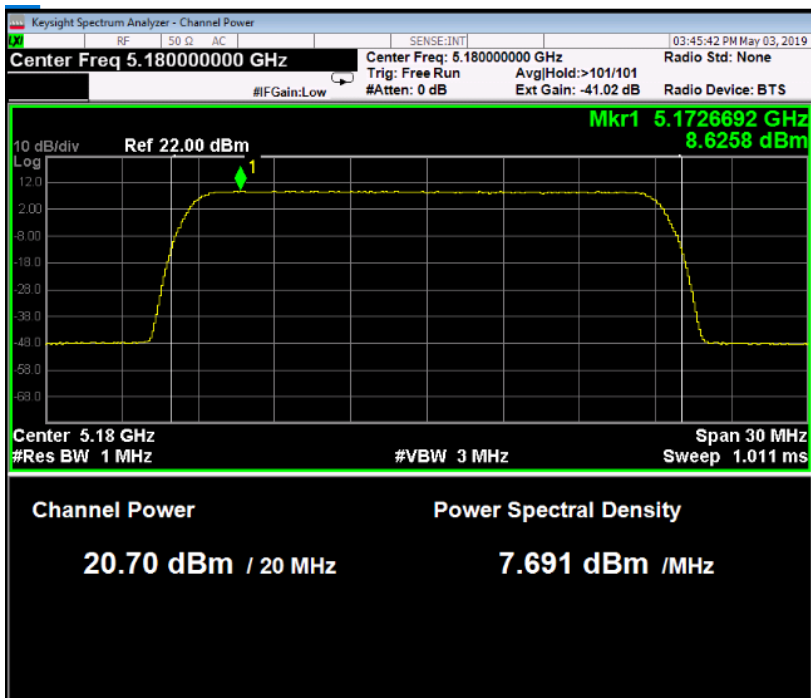
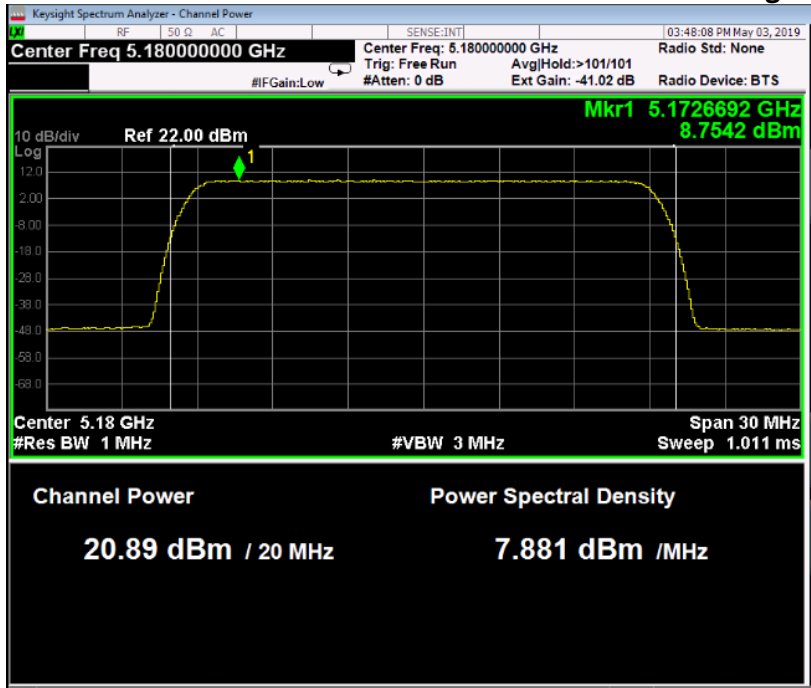

Ch_Power_TM3.1a_2C_2x20MBW_UNII-2_5500/5520_TX1 & TX2 at Antenna Input Port (after the Feedlines) of BA-AIO3O3T3T3VJX65F-06 #8 Ant (Total 20.5dBm for Two Ports)
- Power Setting: 23.6dBm per AZRB Port

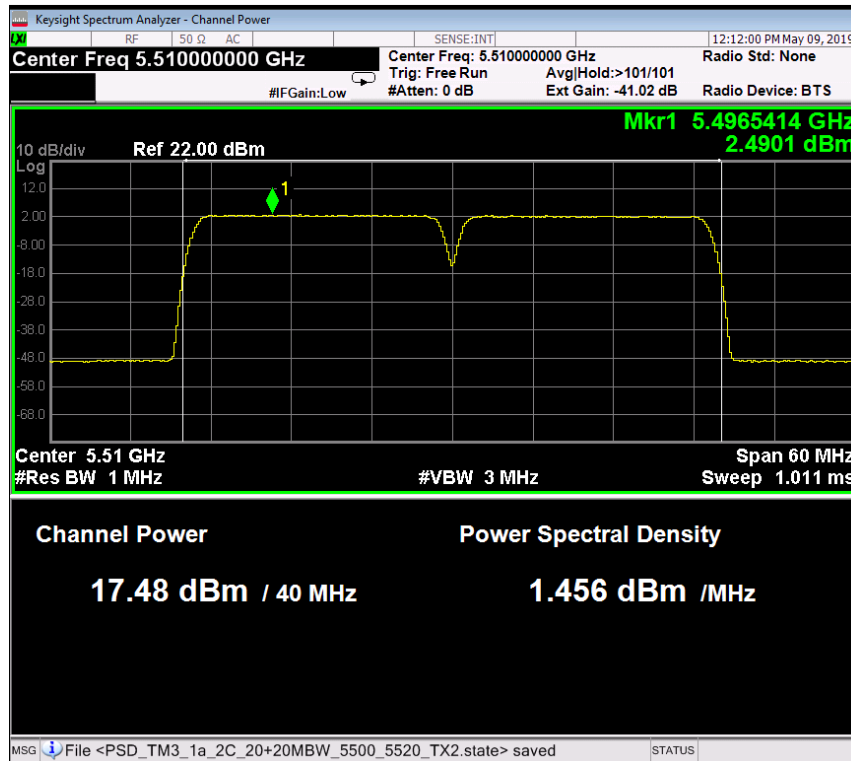
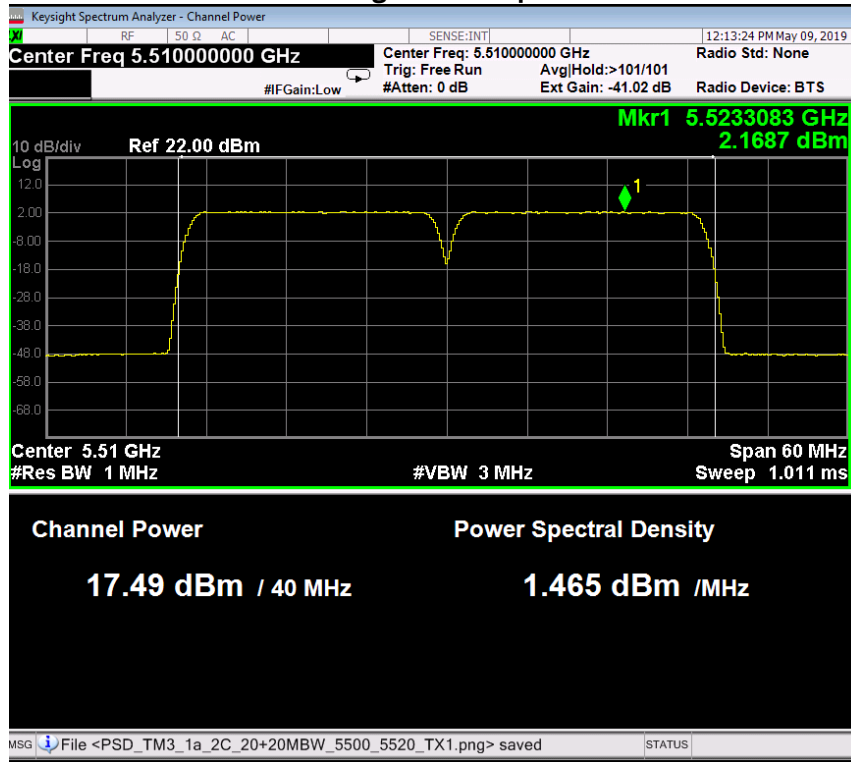

**Ch_Power_TM3.1_3C_3x20MBW_UNII-3_5785/5805/5825_TX1 & TX2 at Antenna Input Port (after the Feedlines) of BA-AIO3O3T3T3VJX65F-06 #8 Ant (Total 23.9dBm for Two Ports)
- Power Setting: 27dBm per AZRB Port**

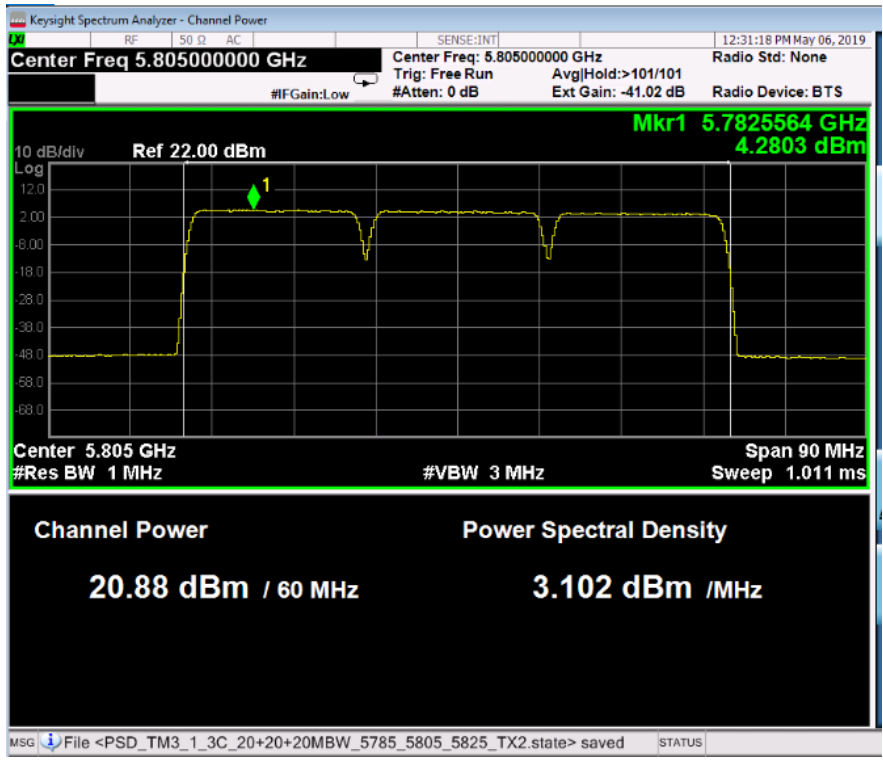
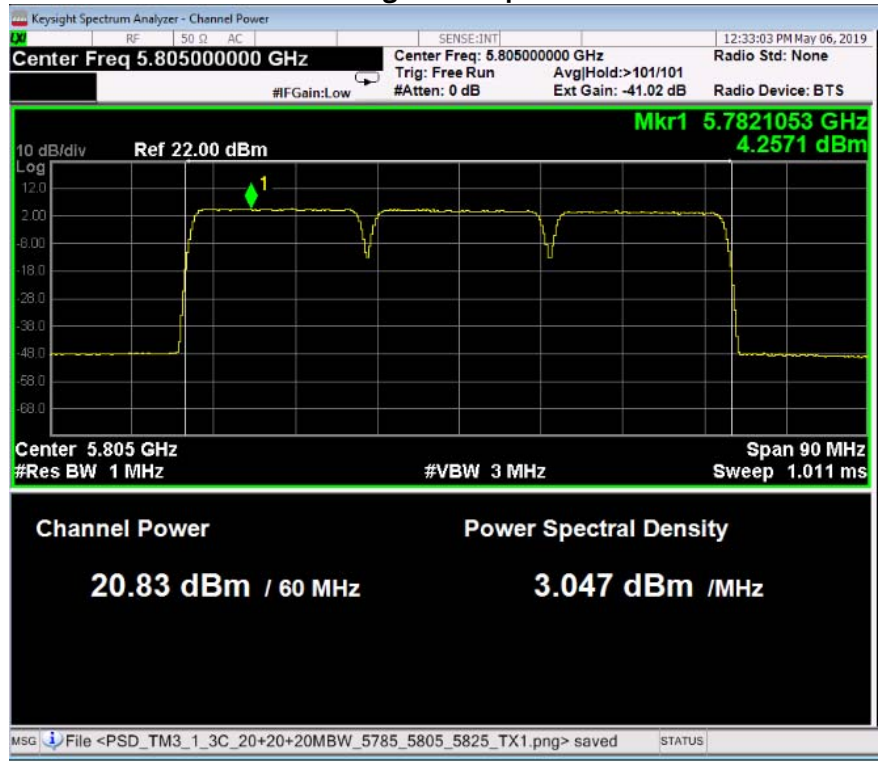

Ch_Power_TM3.2_4C_4x20MBW_UNII-1_5180/5200/5220/5240_TX1 & TX2 at Antenna Input Port (after the Feedlines) of BA-AIO3O3T3T3VJX65F-06 #8 Antenna - Power Setting: 26dBm per AZRB Port

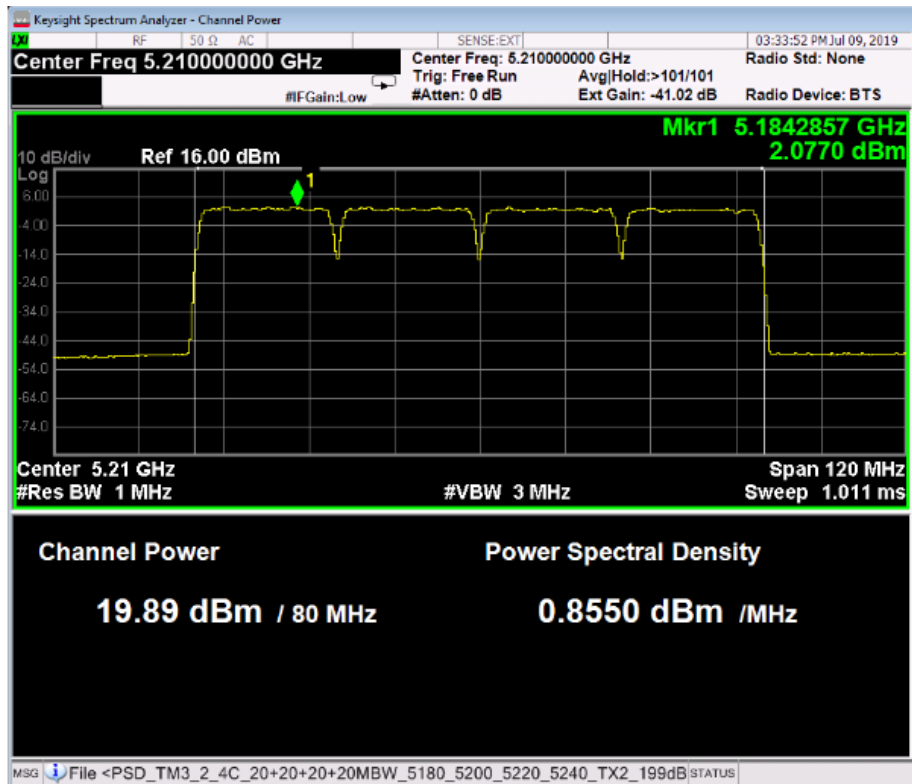
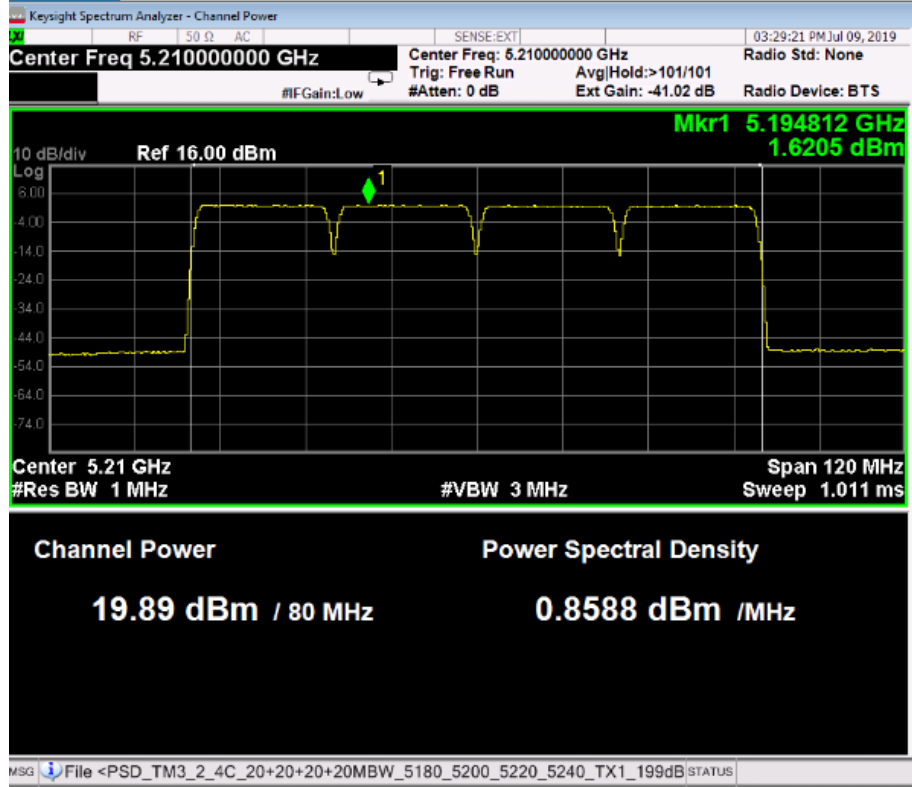

2.1.2 Channel RF Power – Plots PAS2457-CC1 Antenna #9

NOTE: Only the plots with the maximum power output levels for each band are used in this report. The full suite of raw data resides at the MH, New Jersey location. The RF output power levels displayed below were measured at antenna ports with feedlines.

Ch_Power_TM3.2_1C_1x20MBW_UNII-1_5180_TX1 & TX2 at Antenna Input Port (after the Feedlines) of PAS2457-CC1 #9 Antenna (21.90dBm Total for Two Ports) -- Power Setting: 27dBm per AZRB Port

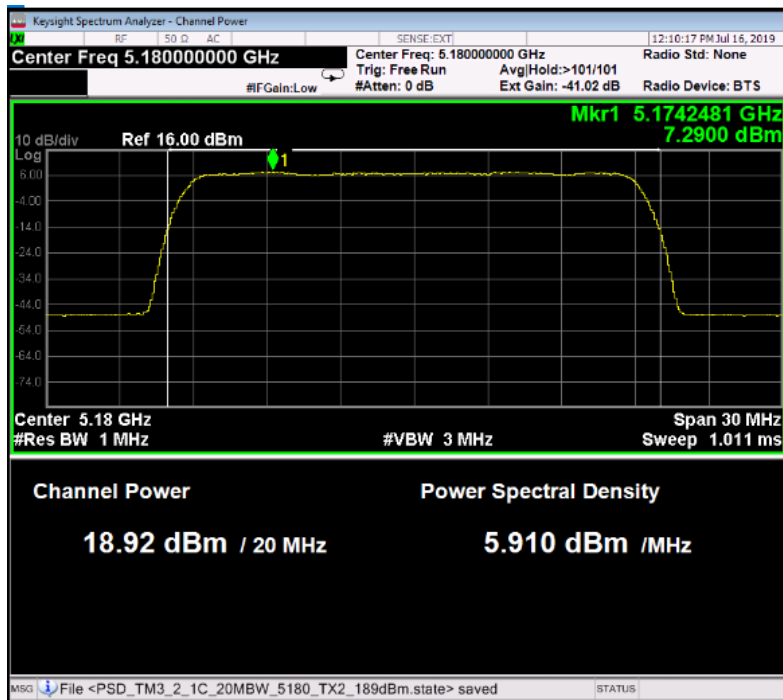
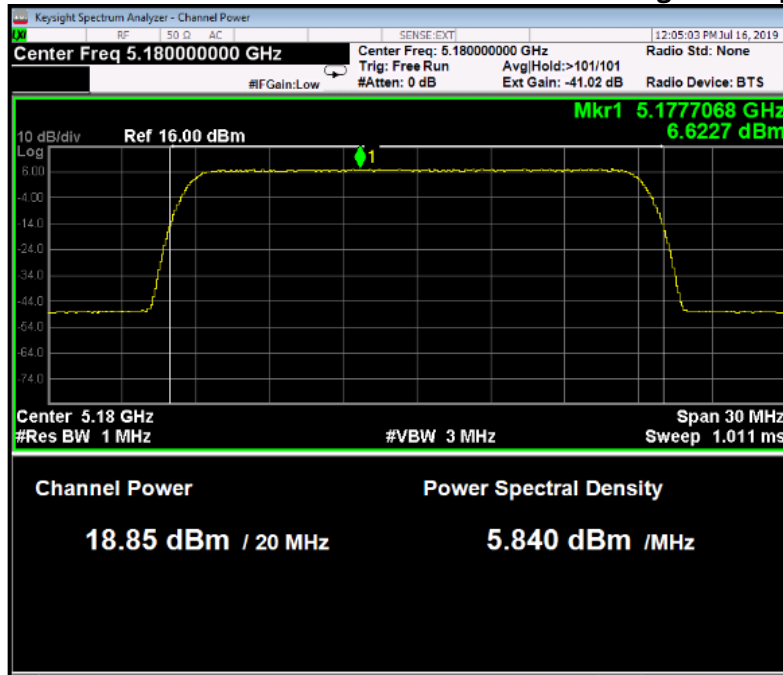

**Ch_Power_TM3.1a_2C_2x20MBW_UNII-2_5500/5520_TX1 & TX2 at Antenna Input Port
(after the Feedlines) of PAS2457-CC1 #9 Antenna (19.39dBm Total for Two Ports)
- Power Setting: 24.2dBm per AZRB Port**

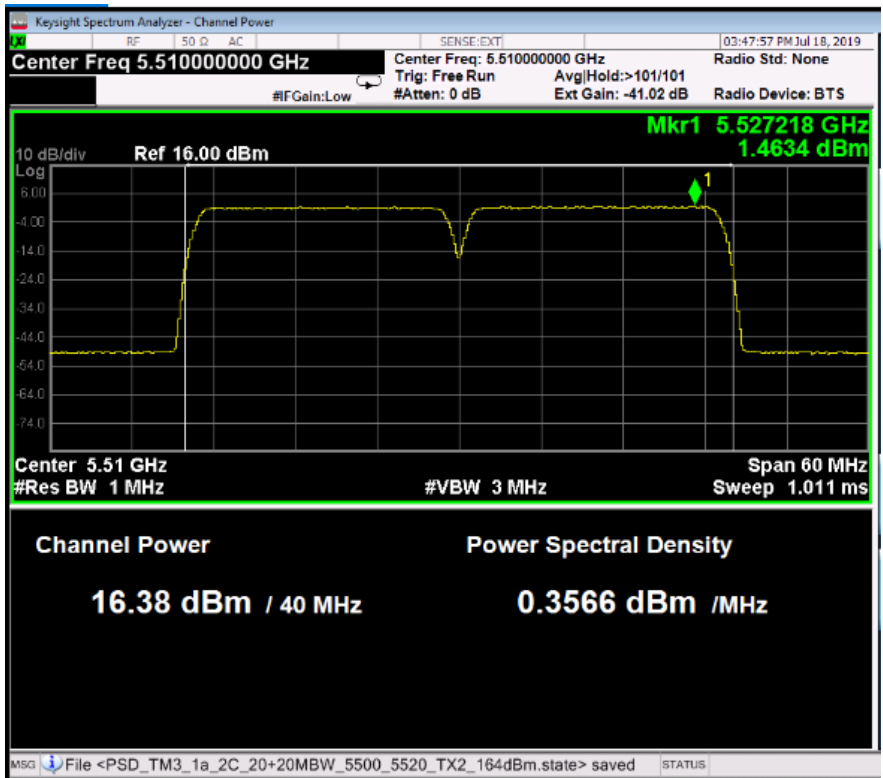
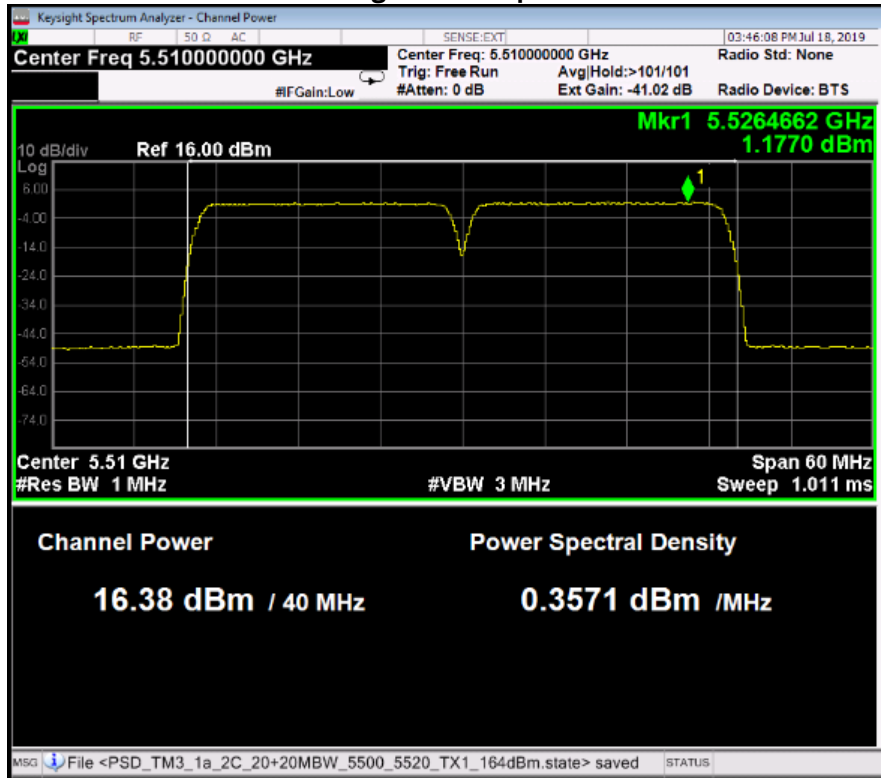

**Ch_Power_TM3.1a_2C_2x20MBW_UNII-3_5805/5825_TX1 & TX2 at Antenna Input Port
(after the Feedlines) of PAS2457-CC1 #9 Antenna (21.90dBm Total for Two Ports)
- Power Setting: 27dBm per AZRB Port**

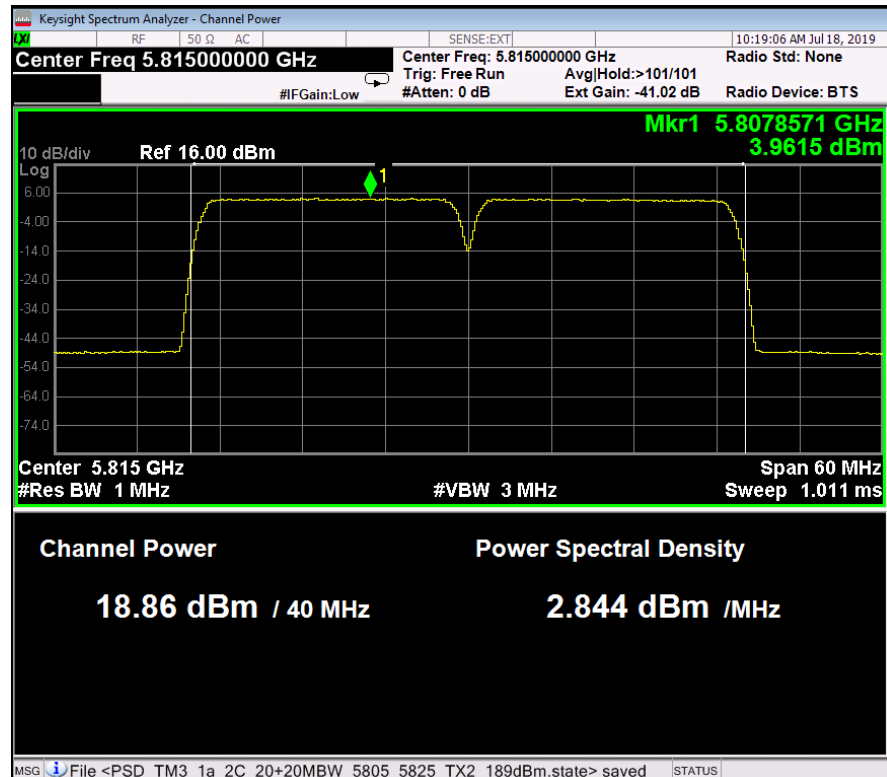
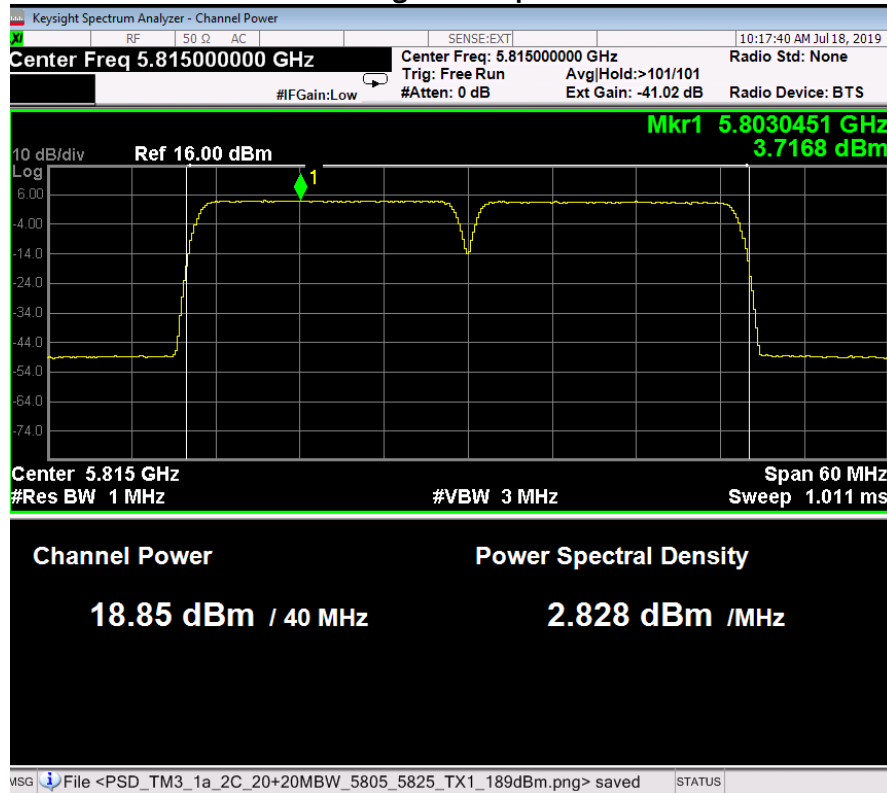

2.2 Maximum Outdoor EIRP

The maximum antenna gains at any elevation angle above 30 degrees as measured from the horizon were provided in Section 1.2. Per KDB 789033 D02 Section II.H.1, for a fixed infrastructure without electrically or mechanically steerable beam antennas, the elevation plane radiation pattern can be used to calculate the maximum EIRP. For MIMO devices, take the maximum gain of each antenna and apply the guidance in KDB 662911 for calculating the overall gain including directional gain for maximum EIRP calculation. Since the EUT does *not* have beamforming function and two signals are *uncorrelated*, the directional antenna gain is the gain of an individual antenna per KDB 662911.

The maximum EIRPs (dBm) of the EUT equipped with the BA-AIO3O3T3T3VJX65F-06 and PAS2457-CC1 antennas in the elevation angle above 30 Degrees in UNII-1 Band (5.15-5.25 GHz) are given in the table below.

**Maximum EIRP (dBm) in the Elevation Angle above 30 Degrees
 in UNII-1 Band (5.15-5.25 GHz)**

Antenna No	Max Power at Each Antenna Port (dBm)	EIRP Limit (dBm)	Allowed Max Antenna Directional Gain above 30° (dBi)	Max Antenna Directional Gain above 30° (dBi)	Results
8	20.9	21	0.1	-4.3	pass
9	18.9	21	2.1	0.0	pass

The maximum EIRP of the EUT equipped with the antennas #8 and #9 at the elevation angles above 30 degrees is less than 21 dBm (125mW) (the limit for an outdoor access point in UNII-1 band) and is in full compliance with the Rules of the Commission.

3. FCC Section 15.407(a) (1-3)(5) – Peak Power Spectrum Density

3.1 Peak Power Spectrum Density

This test is a measurement of the total peak power spectrum density (PPSD), the maximum value of the time average of the PSD measured during a period of continuous transmission at the antenna-transmitting terminals. The product was configured for test as shown in section above and allowed to warm up and stabilize per KDB 789033 D02 and ANSI C63.10.

Transmitter PPSD Limits at Antenna Ports

Band	Antenna	Max Directional Gain for Spectral Density in (dBi)	Total PPSD Limit at Ant Port
UNII-1	#8	9.5	13.5 (dBm/MHz)
UNII-2	#8	9.5	7.5 (dBm/MHz)
UNII-3	#8	9.5	26.5 (dBm/500kHz)
UNII-1	#9	10.5	12.5 (dBm/MHz)
UNII-2	#9	10.5	6.5 (dBm/MHz)
UNII-3	#9	10.5	25.5 (dBm/500kHz)

Power measurements were made with an MXA Signal Analyzer. Only the PPSDs of 1x20MHz carriers were measured for all bands and PPSDs of 2x20MHz were measured for UNII-2 band due to higher power level. The measurement follows the procedures given in KDB 789033 D02. The RBW and VBW were set to 1MHz and 3MHz, respectively. The RMS detector and trace average (≥ 100) were used. The PPSD can be found by using

either the peak search function on the instrument to find the peak of the spectrum or the spectrum analyzer's PSD function.

Maximum Mean Combined PPSD for 1x20MHz Carrier at Antenna Input Ports (after the Feedlines) of Ant #8 BA-AIO3O3T3T3VJX65F-06 - Power Setting per AZRB port: 27dBm for UNII-1/3 & 22.2dBm for UNII-2

Bands (GHz)	Ch No/ Freq (MHz)	Modulation	Port 1 (dBm)	Port 2 (dBm)	Total PPSD (dBm)	PPSD Limit (dBm)	Test Results
UNII-1 (5.17-5.25)	36/5180	Q/16QAM	9.1475	9.0594	12.11	13.5	Pass
		256QAM	8.7542	8.6258	11.70	13.5	Pass
UNII-2a (5.25- 5.35)	64/5320	Q/16QAM	4.3239	4.1798	7.26	7.5	Pass
		256QAM	3.7597	3.9687	6.88	7.5	Pass
UNII-2c (5.47-5.725)	100/5500	Q/16QAM	4.2732	3.9658	7.13	7.5	Pass
		256QAM	3.8899	3.6166	6.77	7.5	Pass
UNII-3 (5.74-5.835)	165/5825	Q/16QAM	8.8760	9.0659	11.98	29.5	Pass
		256QAM	8.6079	8.2531	11.44	29.5	Pass

Maximum Mean Combined PPSD for 5GHz 2x20MHz Carrier at Antenna Input Ports (after the Feedlines) of Antenna #8 BA-AIO3O3T3T3VJX65F-06 - Power Setting per AZRB port: 23.6dBm for UNII-2

Bands (GHz)	Ch No/ Freq (MHz)	Modulation	Port 1 (dBm)	Port 2 (dBm)	Total PPSD (dBm)	PPSD Limit (dBm)	Test Results
UNII-2a (5.25- 5.35)	60, 64/5300, 5320	Q/16QAM	2.4598	3.0155	5.76	7.5	Pass
		64QAM	2.3142	2.4158	5.38	7.5	Pass
		256QAM	2.5686	2.4357	5.51	7.5	Pass
UNII-2c (5.47-5.725)	96, 100/5500, 5520	Q/16QAM	2.8132	3.1029	5.97	7.5	Pass
		64QAM	2.2052	2.3928	5.31	7.5	Pass
		256QAM	2.1687	2.4901	5.34	7.5	Pass

The PPSDs of the AZRB with the feedlines of BA-AIO3O3T3T3VJX65F-06 antenna #8 measured in UNII-1 and UNII-3 are below 12.5dBm/MHz. For the AZRB with PAS2457-CC1 antenna #9, the maximum power setting is 27dBm for 1x20MHz, same as that of with BA-AIO3O3T3T3VJX65F-06 antenna #8. The pathloss of the feedlines of PAS2457-CC1 antenna is 2dB more than that of the BA-AIO3O3T3T3VJX65F-06 antenna. Therefore, the PPSDs of the AZRB with the feedlines of PAS2457-CC1 antenna #9 in UNII-1 and UNII-3 bands shall be below 12.5dBm/MHz limit and their measurement in UNII-1/3 bands can be waived.

Maximum Mean PPSD for 1x20MHz Carrier at Antenna Input Ports (after the Feedlines) of PAS2457-CC1 #9 Antenna - Power Setting per AZRB port: 23.2dBm for UNII-2 (about 15.35 dBm per Antenna Input port)

Bands (GHz)	Ch No/ Freq (MHz)	Modulation	Port 1 (dBm)	Port 2 (dBm)	Total PPSD (dBm)	PPSD Limit (dBm)	Test Results
UNII-2a (5.25- 5.35)	64/5320	Q/16QAM	3.2823	3.1064	6.21	6.5	Pass
		256QAM	3.0351	3.1112	6.08	6.5	Pass
UNII-2c (5.47-5.725)	100/5500	Q/16QAM	3.3351	2.8302	6.10	6.5	Pass
		256QAM	2.8886	2.8895	5.90	6.5	Pass

Maximum Mean PPSD for 2x20MHz Carrier at Antenna Input Ports (after the Feedlines) of PAS2457-CC1 #9 Antenna - Power Setting per AZRB port: 24.2dBm for UNII-2 (about 16.4dBm per Antenna Input Port)

Bands (GHz)	Ch No/ Freq (MHz)	Modulation	Port 1 (dBm)	Port 2 (dBm)	Total PPSD (dBm)	PPSD Limit (dBm)	Test Results
UNII-2a (5.25- 5.35)	60, 64/ 5300, 5320	Q/16QAM	1.6044	1.6803	4.65	6.5	Pass
		256QAM	1.0682	1.4423	4.27	6.5	Pass
UNII-2c (5.47-5.725)	96, 100/ 5500, 5520	Q/16QAM	1.1619	1.7780	4.49	6.5	Pass
		256QAM	1.1770	1.4634	4.33	6.5	Pass

3.1.1 Peak Power Spectrum Density – Plots BA-AIO3O3T3T3VJX65F-06 Antenna #8

NOTE: Only the plots with the maximum levels for each band are used in this report. The full suite of raw data resides at the MH, New Jersey location. The PPSD levels displayed below were measured at antenna ports with feedlines.

Ch_PPST_TM3.2_1C_20MBW_UNII-1_5180_TX1 & TX2_at Antenna Input Port (after the Feedlines) of BA-AIO3O3T3T3VJX65F-06 Antenna #8 - Power Setting: 27dBm per AZRB port

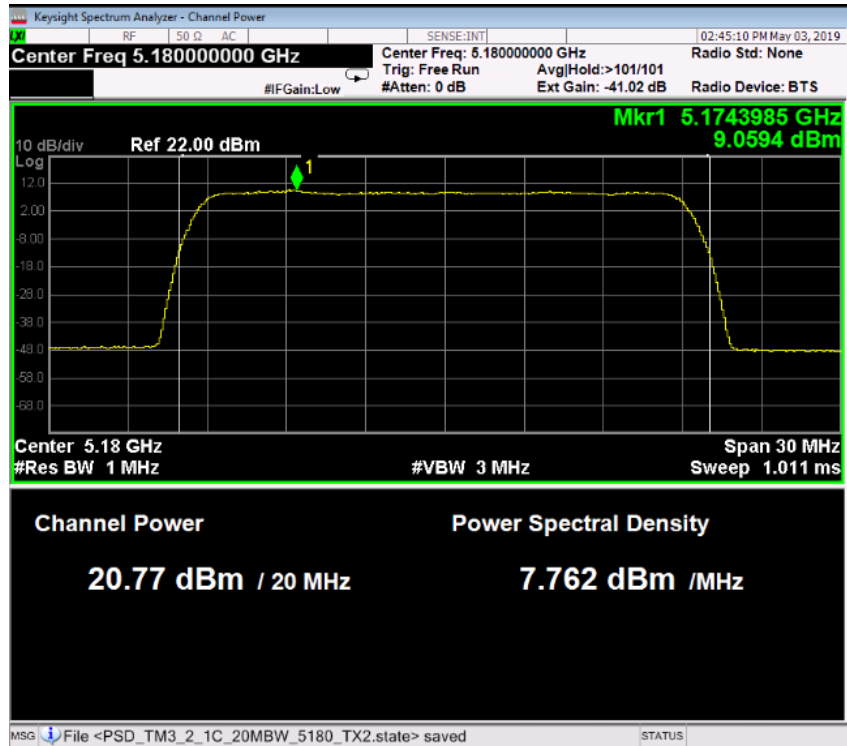
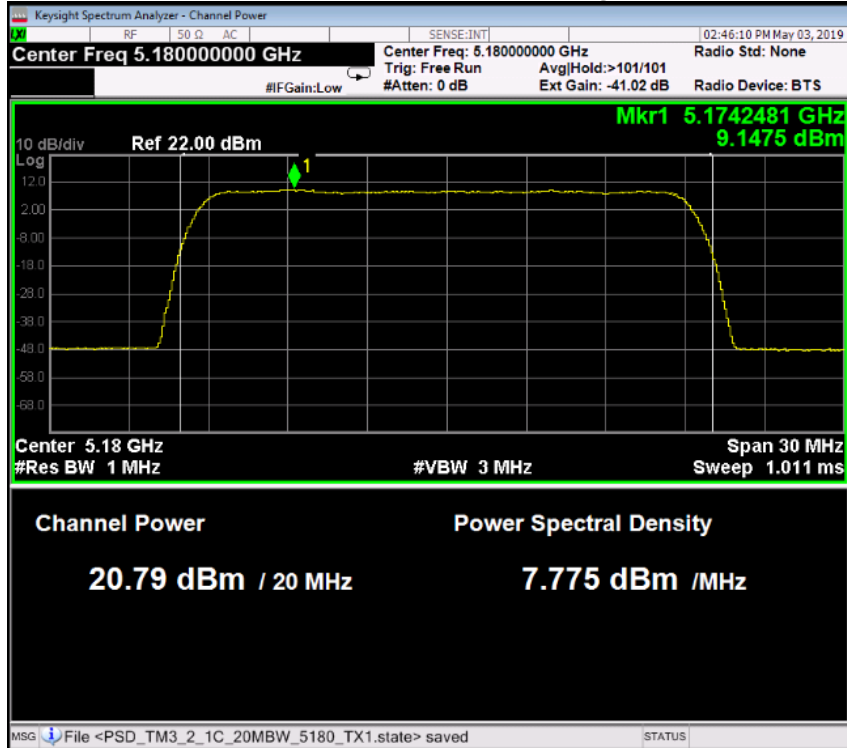

Ch_PPST_T3.2_1C_20MBW_UNII-2_5320_TX1 & TX2 at Antenna Input Port (after the Feedlines) of BA-AIO3O3T3T3VJX65F-06 Antenna #8 - Power Setting: 22.2dBm per AZRB port

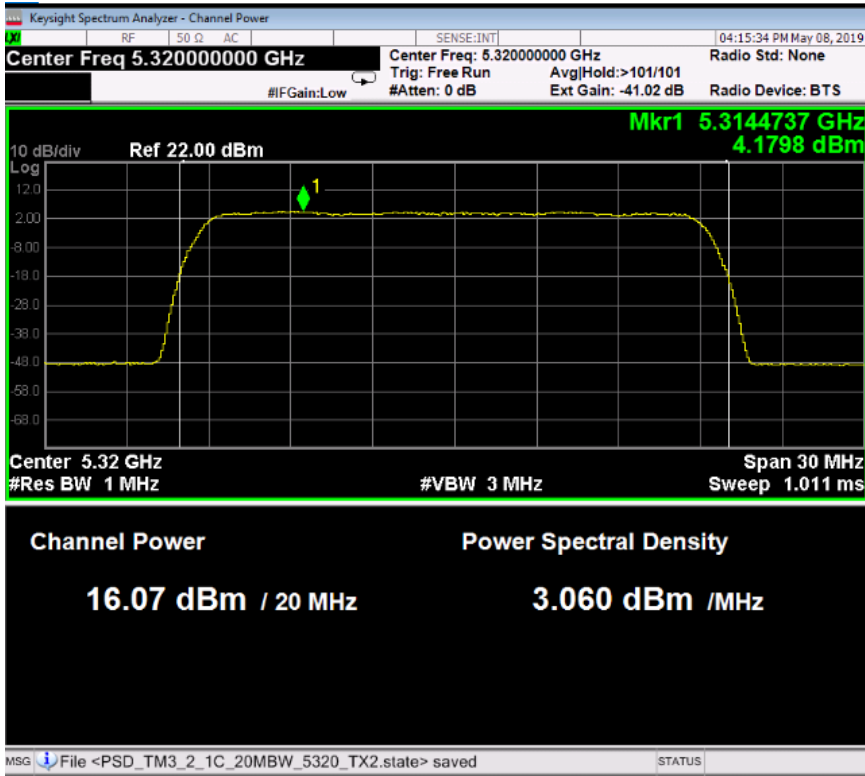
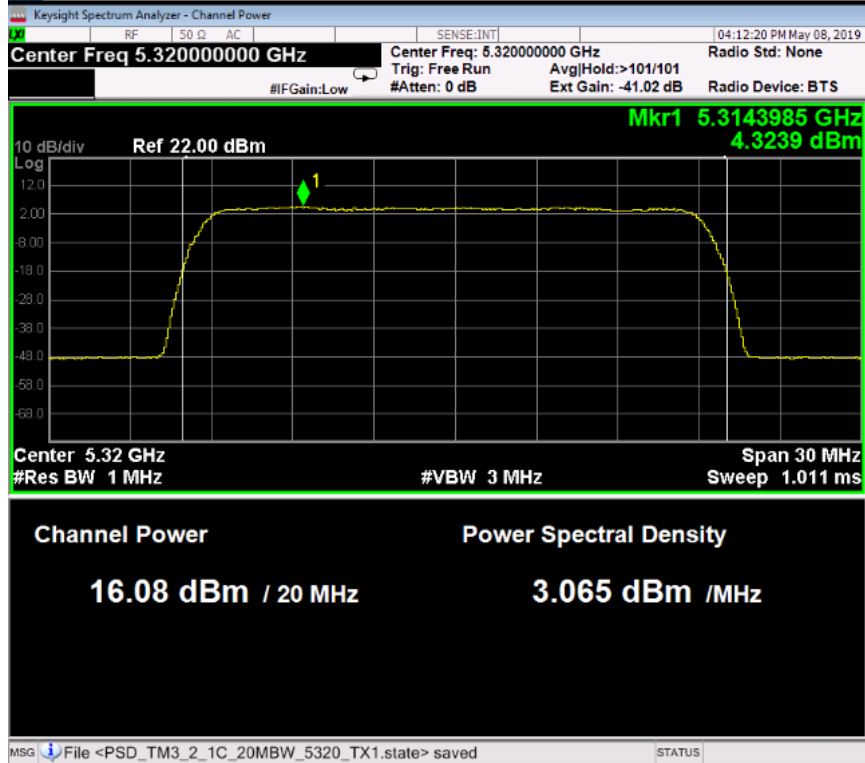

Ch_PP3D_TM3.2_1C_20MBW_UNII-3_5825_TX1 & TX2 at Antenna Input Port (after the Feedlines) of BA-AIO3O3T3T3VJX65F-06 #8 Antenna- Power Setting: 27dBm per AZRB port

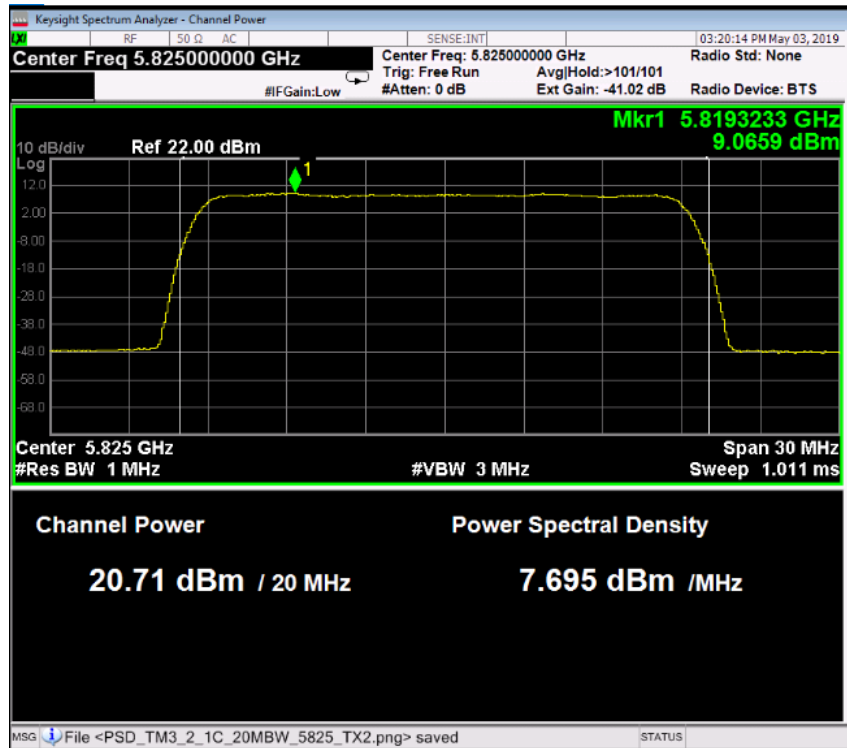
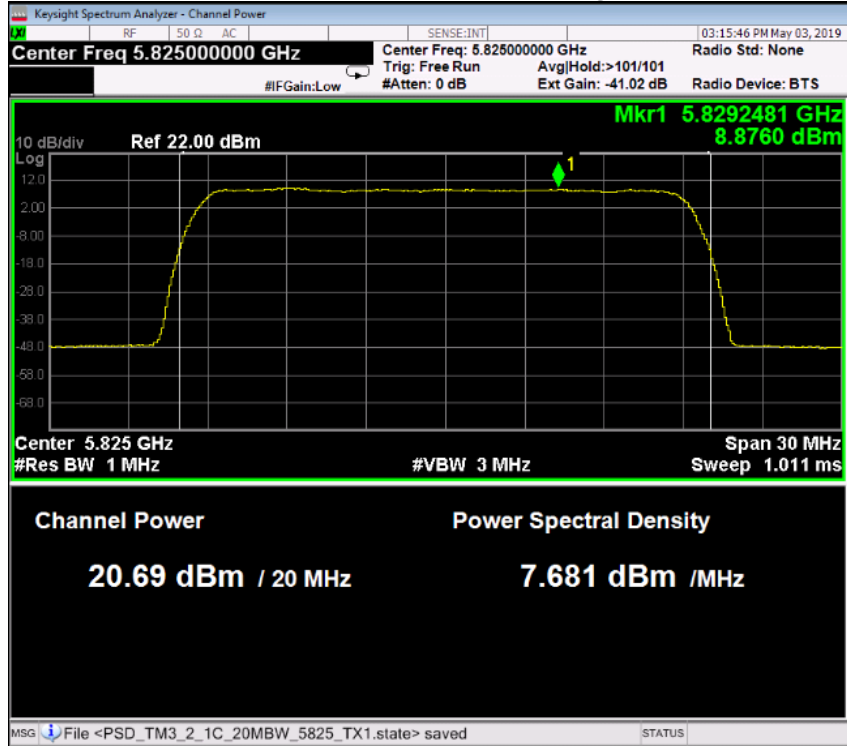

Ch_PPST_TM3.2_2C_2x20MBW_UNII-2_5500/5520_TX1 & TX2 at Antenna Input Port (after the Feedlines)
of BA-AIO3O3T3T3VJX65F-06 Antenna #8 - Power Setting: 23.6dBm per AZRB port

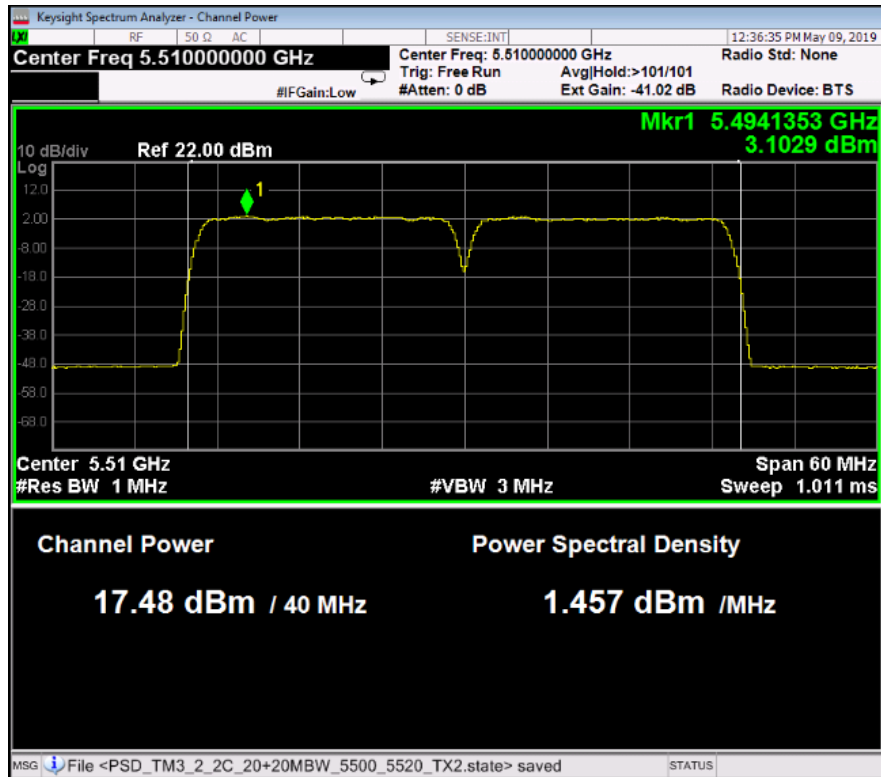
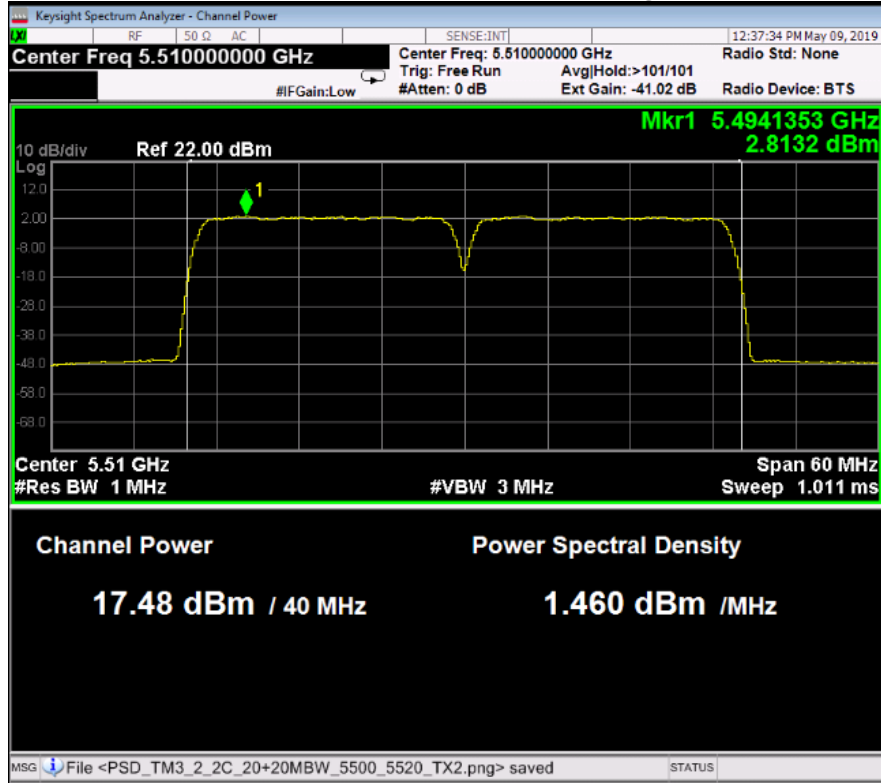

3.1.2 Peak Power Spectrum Density – Plots PAS2457-CC1 Antenna #9

NOTE: Only the plots with the maximum levels for each band are used in this report. The full suite of raw data resides at the MH, New Jersey location. The PPSD levels displayed below were measured at antenna ports with feedlines.

Ch_PPST_TM3.2_1C_1x20MBW_UNII-2_5320_TX1 & TX2_at Antenna Input Port (after the Feedlines) of PAS2457-CC1 Antenna #9 - Power Setting: 23.2dBm per AZRB Port

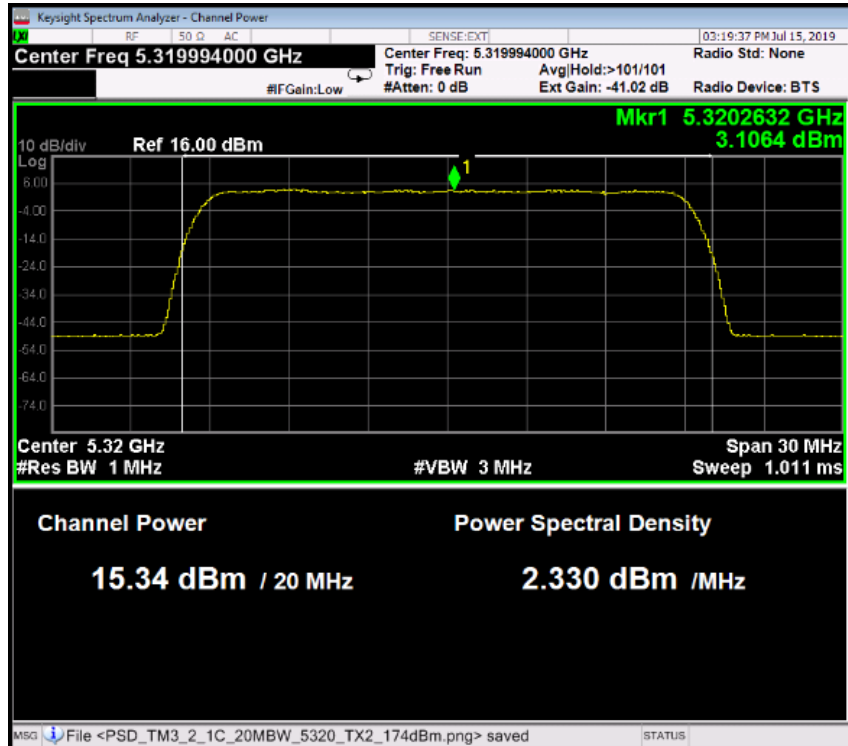
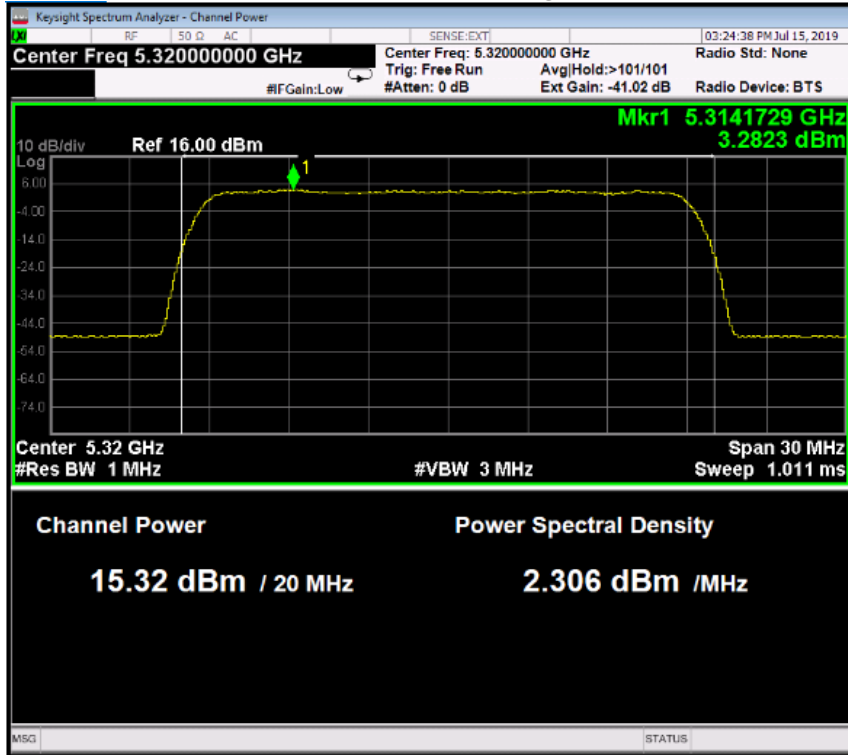

Ch_PPST_TM3.2_2C_2x20MBW_UNII-2_5300/5320_TX1 & TX2_at Antenna Input Port of PAS2457-CC1
Antenna #9 - Power Setting: 24.2dBm per AZRB Port

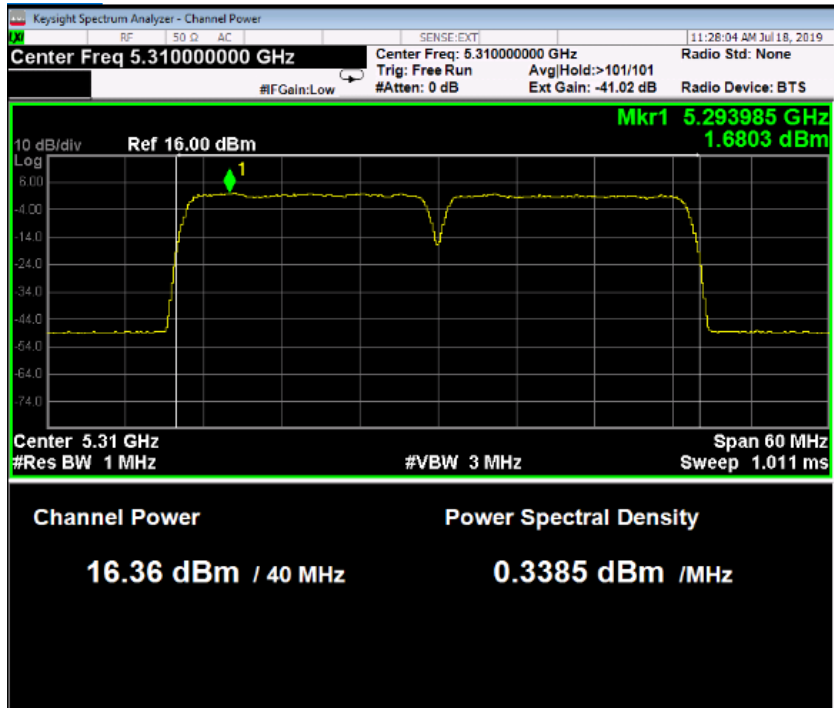
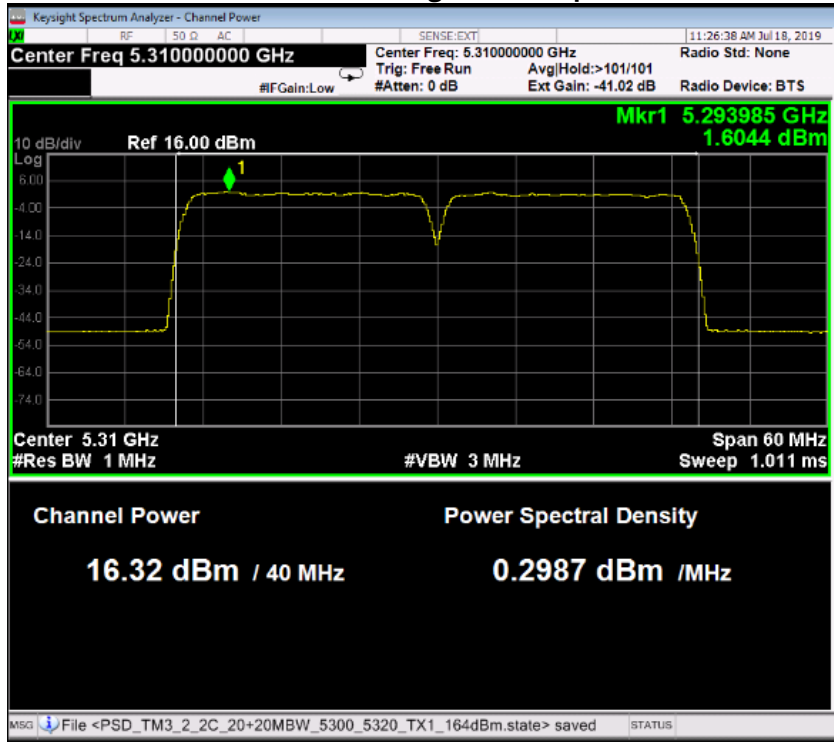

Photographs

AZRB with Feedlines of BA-AIO3O3T3T3VJX65F-06 Antenna

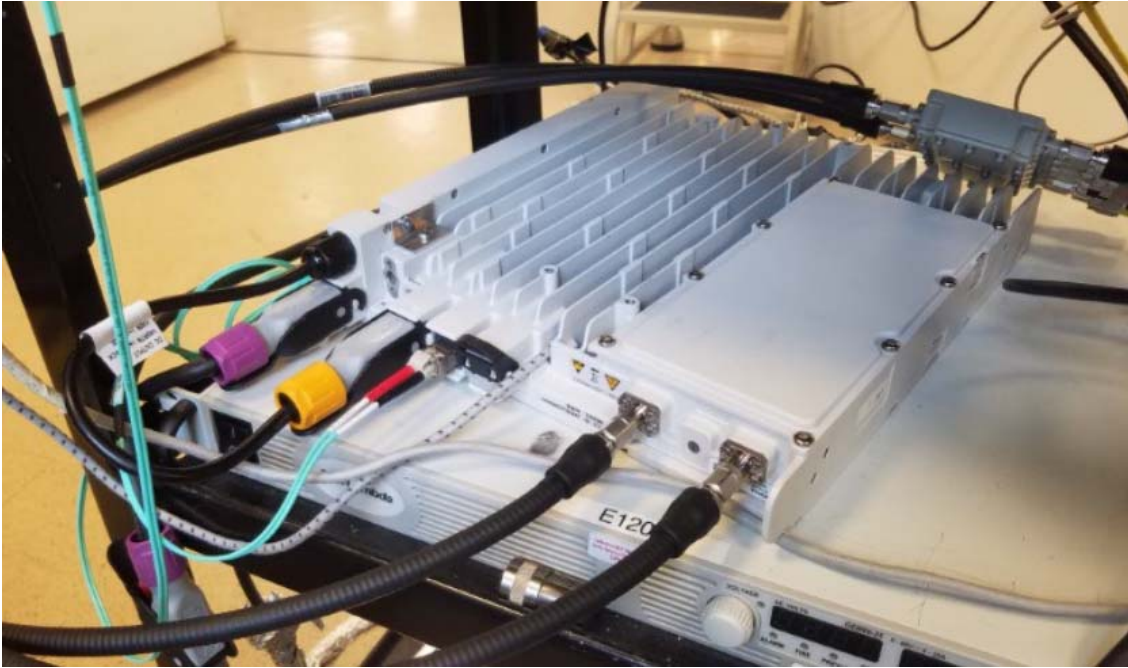

AZRB with Feedlines of PAS2457-CC1 Antenna

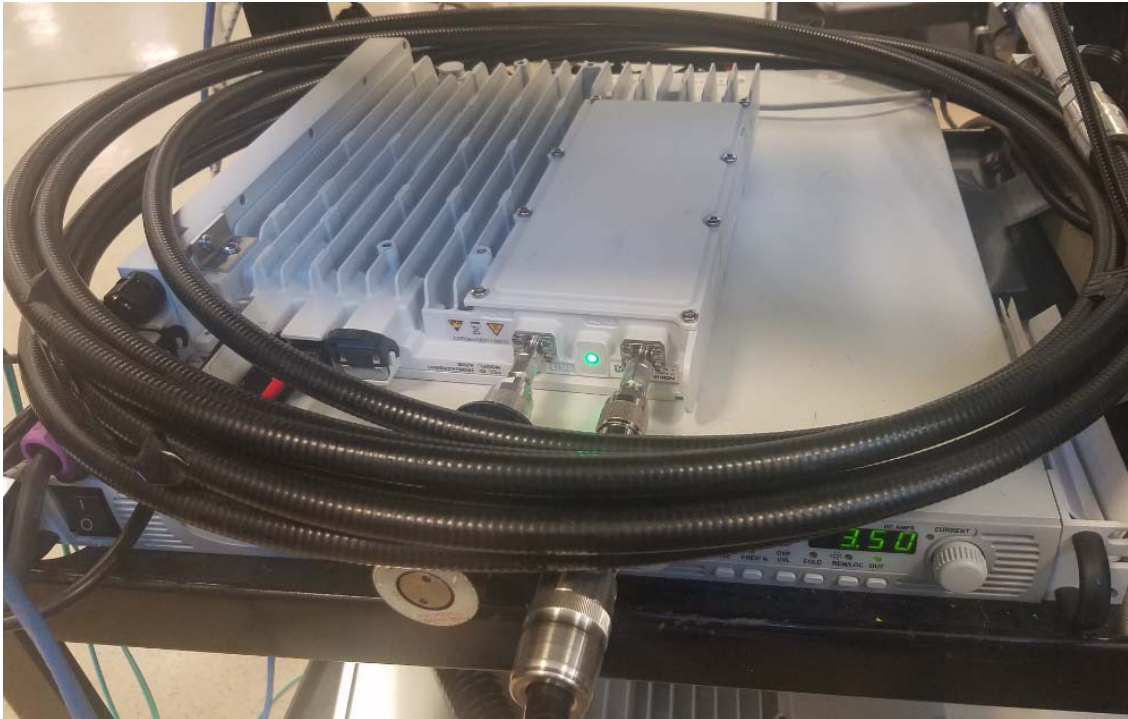

Test Equipment

Asset ID	Manufacturer	Type	Description	Model	Serial	Calibration Date	Calibration Due	Calibration Type
E831	Agilent Technologies	MXA Signal Analyzer	20Hz-26.5GHz	N9020A	MY48011791	2018-02-15	2020-02-15	Requires Calibration
E1155	Weinschel	Attenuator	10dB 25Watt 0.05GHz - 26GHz	74-10-12	1068			Calibration Not Required, Must Be Verified
E1154	Weinschel	Attenuator	30dB 25W 0.05GHz-26GHz	74-30-12	1065			Calibration Not Required, Must Be Verified
	UTIFLEX MICRO-COAX	Cable	UFB142A-0-0720-2G0200/A. MFR65639 227883-001	142A Series 503609-G				Pathloss verified with attenuators
E896	Agilent Technologies	Network Analyzer	10 MHz - 40 GHz	N5230C	MY49000897	2019-01-31	2021-01-31	Requires Calibration

4. FCC Section 15.407(b) (1-5) - Unwanted Radiated Out-of-Band Emissions

4.1 Out of Band Emissions

This test measures the out-of-band emissions, the unwanted emissions outside the band, but near the band edges.

The radiated out of band emissions of the EUT per 15.33 were measured. The recommendations of ANSI C63.10 were followed for the EUT testing setup and cabling. The emissions were maximized by rotating the turntable 360° and moving the receiving antenna height to scan and capture the emissions from the EUT.

4.2 Out of Band Emissions Limits

Per FCC 15.407(b)(1-5), the unwanted emission limits are:

- (1) For transmitters operating in the 5.15-5.25 GHz band: all emissions outside of the 5.15-5.35 GHz band shall not exceed an EIRP of -27 dBm/MHz.
- (2) For transmitters operating in the 5.25-5.35 GHz band: all emissions outside of the 5.15-5.35 GHz band shall not exceed an EIRP of -27 dBm/MHz.
- (3) For transmitters operating in the 5.47-5.725 GHz band: all emissions outside of the 5.47-5.725 GHz shall not exceed an EIRP of -27 dBm/MHz.
- (4) For transmitters operating in the 5.725-5.85 GHz band:

All emissions shall be limited to a level of -27 dBm/MHz at 75 MHz or more above or below the band edge increasing linearly to 10 dBm/MHz at 25 MHz above or below the band edge, and from 25 MHz above or below the band edge increasing linearly to a level of 15.6 dBm/MHz at 5 MHz above or below the band edge, and from 5 MHz above or below the band edge increasing linearly to a level of 27 dBm/MHz at the band edge.
- (5) The emission measurements shall be performed using a minimum resolution bandwidth of 1 MHz. A lower resolution bandwidth may be employed near the band edge, when necessary, provided the measured energy is integrated to show the total power over 1 MHz.
- (6) Unwanted emissions below 1 GHz must comply with the general field strength limits set forth in 15.209.
- (7) The field strength of emissions appearing *within Section 15.205 restricted frequency bands* shall not exceed the limits shown in Section 15.209. Above 1GHz, compliance with the emission limits in Section 15.209 shall be demonstrated based on the *average* value of the measured emissions. The provisions in Section 15.35 apply to these measurements.

Per KDB 789033 D02, for the radiated measurement, the field strength limit is obtained from the EIRP limit by

$$E \text{ (dB}\mu\text{V/m)} = \text{EIRP(dBm)} - 20 * \log(d) + 104.77,$$

where

- E is the field strength in V/m;

- d is the measurement distance in m;
- EIRP is the equivalent isotropically radiated power in W.

At 3m with EIRP = - 27dBm, E = 68.2 dBµV/m.

FCC Part 15.205 (a) Restricted Bands of Operation

MHz	MHz	MHz	GHz
0.090 - 0.110	16.42 - 16.423	399.9 - 410	4.5 - 5.15
0.495 - 0.505	16.69475 - 16.69525	608 - 614	5.35 - 5.46
2.1735 - 2.1905	16.80425 - 16.80475	960 - 1240	7.25 - 7.75
4.125 - 4.128	25.5 - 25.67	1300 - 1427	8.025 - 8.5
4.17725 - 4.17775	37.5 - 38.25	1435 - 1626.5	9.0 - 9.2
4.20725 - 4.20775	73 - 74.6	1645.5 - 1646.5	9.3 - 9.5
6.215 - 6.218	74.8 - 75.2	1660 - 1710	10.6 - 12.7
6.26775 - 6.26825	108 - 121.94	1718.8 - 1722.2	13.25 - 13.4
6.31175 - 6.31225	123 - 138	2200 - 2300	14.47 - 14.5
8.291 - 8.294	149.9 - 150.05	2310 - 2390	15.35 - 16.2
8.362 - 8.366	156.52475 - 156.52525	2483.5 - 2500	17.7 - 21.4
8.37625 - 8.38675	156.7 - 156.9	2690 - 2900	22.01 - 23.12
8.41425 - 8.41475	162.0125 - 167.17	3260 - 3267	23.6 - 24.0
12.29 - 12.293	167.72 - 173.2	3332 - 3339	31.2 - 31.8
12.51975 - 12.52025	240 - 285	3345.8 - 3358	36.43 - 36.5
12.57675 - 12.57725	322 - 335.4	3600 - 4400	Above 38.6
13.36 - 13.41			

FCC 15.407E UNII-2 Out-of-Band Radiated Emission limits

Band (GHz)	Freq Investigated (GHz)	Emission Limits		Detector	RBW (MHz)
		Freq Range (GHz)	Limit (dBµV/MHz)		
5.15-5.25	5.10-5.40	4.5 < f < 5.15 &	54/68.2	ave/pk	1
		5.35 < f < 5.46			
5.25-5.35	5.10-5.40	4.5 < f < 5.15 &	54/68.2	ave/pk	1
		5.35 < f < 5.46			
5.47-5.725	5.40-5.8 (w/o Ch 144)	5.35 < f < 5.46	54/68.2	ave/pk	1
		5.46 < f < 5.47 & 5.725 < f < 7.25	68.2	pk	
	5.40-5.90 (with Ch 144)	5.35 < f < 5.46	54/68.2	ave/pk	
		5.46 < f < 5.47 & 5.85 < f < 7.25	68.2	pk	
5.725-5.85	5.625-5.950	f ≤ 5.650 ¹ & 5.925 ≤ f	68.2	pk	1
		5.650 ≤ f ≤ 5.700 ² & 5.875 ≤ f ≤ 5.925	68.2 to 105.2	pk	
		5.700 ≤ f ≤ 5.720 ³ & 5.855 ≤ f ≤ 5.875	105.2 to 110.8	pk	
		5.720 ≤ f ≤ 5.725 ⁴ & 5.850 ≤ f ≤ 5.855	110.8 to 122.2	pk	

¹: $75^2 \leq \Delta f^1$, where Δf is the frequency away from band edges at 5.725 GHz and 5.85GHz, respectively;

²: $25 \leq \Delta f \leq 75$; ³: $5 \leq \Delta f \leq 25$; ⁴: $0 \leq \Delta f \leq 5$.

NOTE: 1) Only the out-of-band emissions plots which give the minimum emission margin evaluated for 1x20MHz, 3x20MHz and 4x20MHz carriers were used in this report. The full suite of raw data resides at the MH, New Jersey location. 2) "NA" (Not Applicable) in the tables of Formal Data below was due to the fact that only the unwanted emissions in the restricted band above 1GHz are subject to the average 54 dBuV/m limit per FCC 15.205 and 15.209.

4.2.1 Out of Band Emissions – Plots BA-AIO3O3T3T3VJX65F-06 Antenna #8

The out-of-band emissions measured for the EUT equipped with directional antenna BA-AIO3O3T3T3VJX65F-06 #8 are all below the FCC average and/or peak limits required in both the restricted and non-restricted bands.

OOBE_TM3.2_1C_20MBW_UNII-3_5825_30dBm total BA-AIO3O3T3T3VJX65F-06

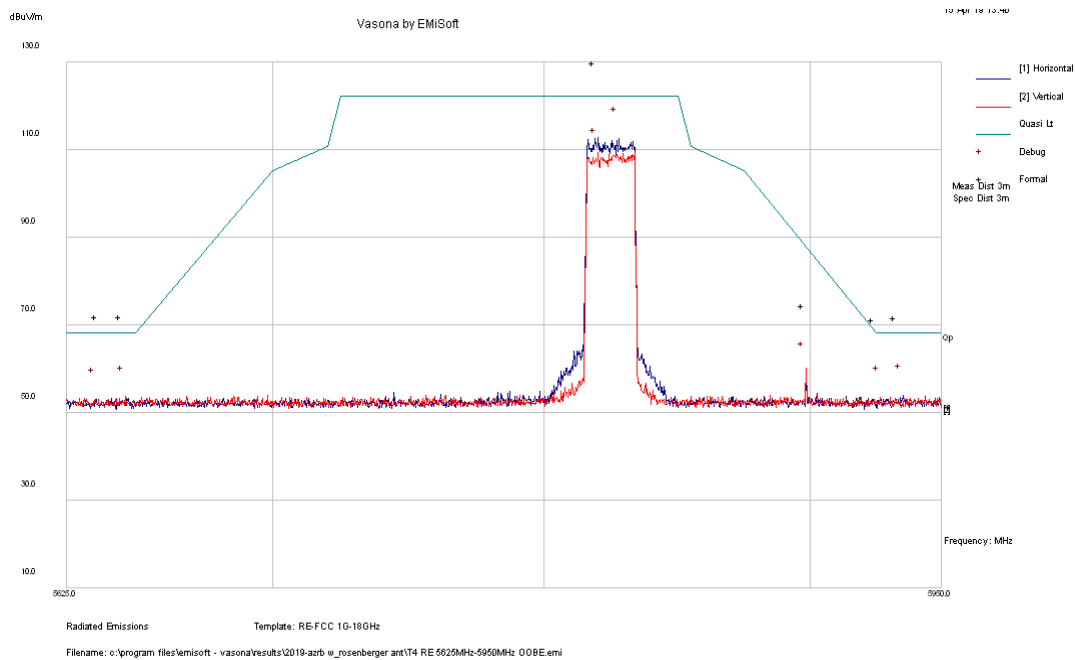

Results Title: RE-FCC 5.625G-5.950GHz OOBE
File Name: c:\program files\emisoft - vasona\results\2019-azrb_w_rosenberger ant\T4 RE 5625MHz-5950MHz OOBE.emi

Test Laboratory: AR4-MH, 24C, 44% 977mB
Test Engineer: GM

Test Software: Vasona by EMISoft, version 2.161
Equipment: Nokia
EUT Details: AZRB PN: 474510A.101, S/N: 1M181319958 with Rosenberger Base Station Antenna PN: BA-AIO3O3T3T3VJX65F-06, SN: RAPAF01183927707, Power Supply Module PN: 474130A.102, S/N: U7182703949, Modulation TM3.2, 27dBm, 1C transmitting @ 5825MHz, 20MHz BW, UNII 3.

Configuration: Powered by 120Vac, Tested to FCC Class B, RE 4950MHz-5550MHz, (OOBE) @ 3-Meters Horn Antenna E1073, ESU IH69, Pre-Amp E1356, 16dB pads-E176+E177. Internal attenuation 0dB, Preview BW (30 kHz RBW/ 3000 KHz VBW); Formal BW (1MHz RBW). Radiated Emissions; FCC Pt15 Class B, 3 Meters

Date: 2019-04-15 13:40:10

FORMAL DATA

Freq. (MHz)	Raw (dBuV)	Cable (dB)	Factor (dB)	Level (dBuV/m)	Emission Type	Pol (H/V)	Ht (cm)	Az (deg)	Limit (dBuV/m)	Margin (dB)	Pass /Fail	Comments
5819.45	103.05	21.59	-1.75	122.89	Peak Max	V	235	355	122.2	0.69	Fail	Tx Exempt
5636.78	45.33	21.52	-1.89	64.96	Peak Max	H	149	328	68.2	-3.24	Pass	
5645.42	45.28	21.52	-1.88	64.92	Peak Max	V	362	41	68.2	-3.28	Pass	
5933.21	44.59	21.63	-1.67	64.56	Peak Max	H	367	56	68.2	-3.64	Pass	
5924.79	44.3	21.63	-1.67	64.25	Peak Max	V	154	17	68.35	-4.1	Pass	
5898.32	47.56	21.62	-1.69	67.48	Peak Max	V	98	0	87.9	-20.42	Pass	

PREVIEW DATA

Freq. (MHz)	Raw (dBuV)	Cable (dB)	Factor (dB)	Level (dBuV/m)	Emission Type	Pol (H/V)	Ht (cm)	Az (deg)	Limit (dBuV/m)	Margin (dB)	Pass /Fail	Comments
5827.9	92.6	21.59	-1.75	112.45	Debug	H	98	360	122.2	-9.75	Pass	
5935.18	33.9	21.64	-1.67	53.87	Debug	H	98	360	68.2	-14.33	Pass	
5819.96	87.7	21.59	-1.75	107.54	Debug	V	98	360	122.2	-14.66	Pass	
5646.33	33.81	21.52	-1.88	53.45	Debug	V	98	360	68.2	-14.75	Pass	
5926.59	33.49	21.63	-1.67	53.45	Debug	V	98	360	68.2	-14.75	Pass	
5635.73	33.24	21.52	-1.89	52.87	Debug	H	98	360	68.2	-15.33	Pass	
5898.39	38.9	21.62	-1.69	58.83	Debug	V	98	360	87.85	-29.02	Pass	

Note: Preview data was measured using a peak detector to identify frequencies of interest for formal measurement. Formal data consist of all frequencies in the preview list within 6 dB of specification limit or the top six frequencies. Failure in preview data does not necessarily constitute failure in formal data.

Oobe_TM3.1a/3.1/3.2_3C_20MBW_UNII-3_5785/5805/5825_30dBm total BA-AIO3O3T3T3VJX65F-06

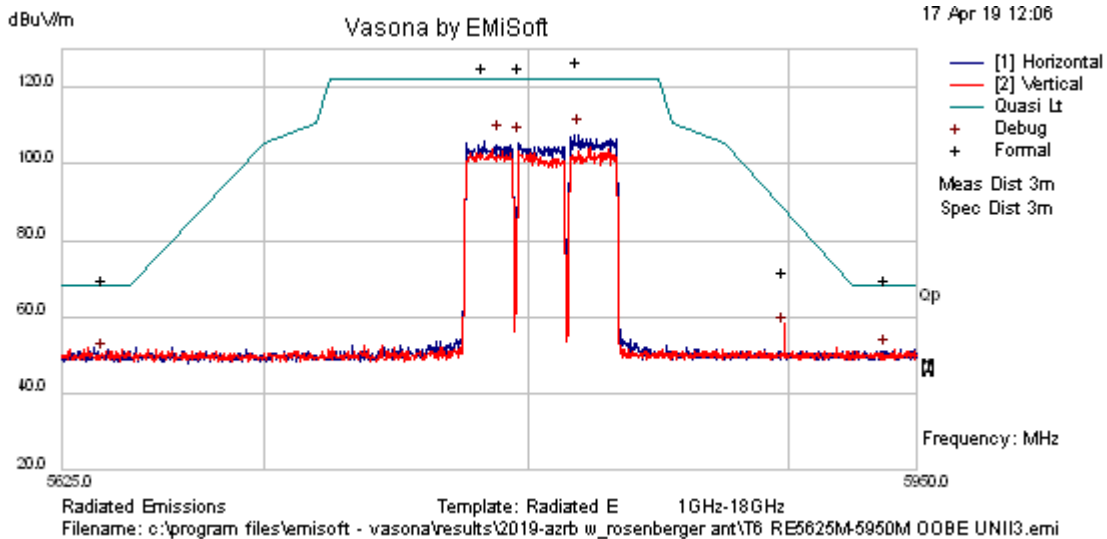

Results Title:	RE 5.625GHz-5.925GHz Oobe UNII-3
File Name:	c:\program files\emisoft - vasona\results\2019-azrb w_rosenberger ant\T5 RE5625M-5950M Oobe UNII3.emi
Test Laboratory:	AR4-MH, 24C, 14% 999mB

Test Engineer:	GM / MJS
Test Software:	Vasona by EMISoft, version 2.161
Equipment:	Nokia
EUT Details:	AZRB PN: 474510A.101, S/N: 1M181319958 with Rosenberger Base Station Antenna PN: BA-AIO3O3T3T3VJX65F-06, SN: RAPAF01183927707, Power Supply Module PN: 474130A.102, S/N: U7182703949, Modulation ETM3.1a/ETM3.1/ETM3.2, 27dBm, 3C transmitting @ 5785MHz, 5805MHz, 5825MHz, 60MHz BW H, UNII 3.
Configuration:	Powered by 120Vac, Tested to FCC Class B, RE 4950MHz-5550MHz, (OOBE) @ 3-Meters Horn Antenna E1073, ESU IH69, Pre-Amp E1356, 16dB pads-E176+E177. Internal attenuation 10dB, Preview BW (30 kHz RBW/ 3000 KHz VBW); Formal BW (1MHz RBW). Radiated Emissions; FCC Pt15 Class B, 3 Meters
Date:	2019-04-16 19:11:23

FORMAL DATA												
Freq. (MHz)	Raw (dBuV)	Cable (dB)	Factor (dB)	Level (dBuV/m)	Emission Type	Pol (H/V)	Ht (cm)	Az (deg)	Limit (dBuV/m)	Margin (dB)	Pass /Fail	Comments
5819.21	102.3	21.59	-1.8	122.09	Peak	H	201	14	122.2	-0.11	Pass	Tx
5783.04	100.81	21.58	-1.83	120.56	Peak	H	217	4	122.2	-1.64	Pass	
5796.58	100.77	21.58	-1.82	120.53	Peak	H	198	13	122.2	-1.67	Pass	
5640.5	45.83	21.52	-1.96	65.39	Peak	H	240	327	68.2	-2.81	Pass	
5937.98	45.11	21.64	-1.7	65.04	Peak	H	129	224	68.2	-3.16	Pass	
5898.41	47.4	21.62	-1.74	67.29	Peak	V	149	357	87.84	-20.55	Pass	

PREVIEW DATA												
Freq. (MHz)	Raw (dBuV)	Cable (dB)	Factor (dB)	Level (dBuV/m)	Emission Type	Pol (H/V)	Ht (cm)	Az (deg)	Limit (dBuV/m)	Margin (dB)	Pass /Fail	Comments
5819.28	87.87	21.59	-1.8	107.66	Debug	H	180	0	122.2	-14.54	Pass	
5789.13	86.31	21.58	-1.83	106.06	Debug	H	180	0	122.2	-16.14	Pass	
5796.58	85.67	21.58	-1.82	105.43	Preview	H	180	0	122.2	-16.77	Pass	
5937.98	30.28	21.64	-1.7	50.21	Debug	H	101	352	68.2	-17.99	Pass	
5640.5	29.35	21.52	-1.96	48.91	Debug	H	101	352	68.2	-19.29	Pass	

Note: Preview data was measured using a peak detector to identify frequencies of interest for formal measurement. Formal data consist of all frequencies in the preview list within 6 dB of specification limit or the top six frequencies. Failure in preview data does not necessarily constitute failure in formal data.

OOBE_TM3.2_4C_20MBW_UNII-3_5765/5785/5805/5825_29dBm total BA-AIO3O3T3T3VJX65F-06

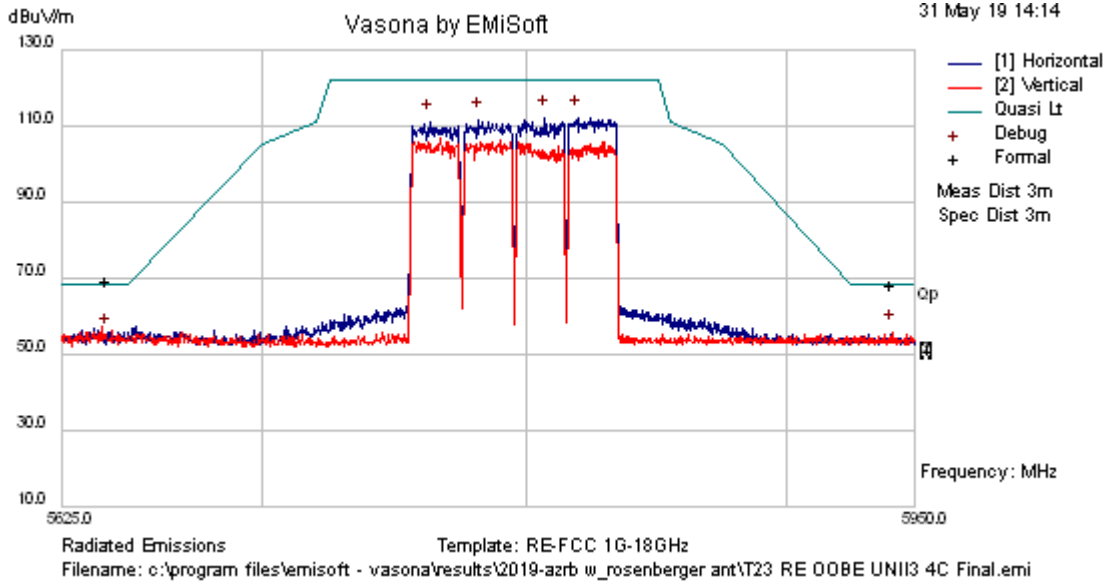

Results Title:	RE-FCC 5.625G-5.95GHz OOBE UNII-3 4C
File Name:	c:\program files\emisoft - vasona\results\2019-azrb w_rosenberger ant\T23 RE OOBE UNII3 4C Final.emi
Test Laboratory:	AR4-MH, 24C, 44% 977mB
Test Engineer:	MJS
Test Software:	Vasona by EMISoft, version 2.161
Equipment:	Nokia
EUT Details:	2019-0082 AZRB PN: 474510A.101, S/N: 1M181319958 with Rosenberger Base Station Antenna PN: BA-AIO3O3T3T3VJX65F-06, SN: RAPAFO1183927707, Power Supply Module PN: 474130A.102, S/N: U7182703949, Modulation ETM3.2, 26dBm, 4C-UNII-3 - Transmitting @ 5765M, 5785M, 5805M, 5825MHz, 80MHz BW L, Powered by 120VAC. Tx Back on, full scan with formals.
Configuration:	Radiated Emissions 5.625GHz - 5.95GHz, OOBE, FCC Class B Limit, Ant E1073, RCVR ESU-1G IH69, Pre-Amp E447, 10dB pad-E177 and 6dB pad- E176, Ref Lvl 130dB, Int attn 10dB, Preview RBW 100kHz Formal RBW 1MHz, 3m measurement distance, straight bore, no tilt.
Date:	2019-05-31 14:14:35

FORMAL DATA												
Freq. (MHz)	Raw (dBuV)	Cable (dB)	Factor (dB)	Level (dBuV/m)	Emission Type	Pol (H/V)	Ht (cm)	Az (deg)	Limit (dBuV/m)	Margin (dB)	Pass /Fail	Comments
5940.77	44.9	21.35	-3.14	63.1	Peak	V	129	199	68.2	-5.1	Pass	
5642.25	46.2	21.11	-3.37	63.94	Peak	H	127	261	68.2	-4.26	Pass	

PREVIEW DATA												
Freq. (MHz)	Raw (dBuV)	Cable (dB)	Factor (dB)	Level (dBuV/m)	Emission Type	Pol (H/V)	Ht (cm)	Az (deg)	Limit (dBuV/m)	Margin (dB)	Pass /Fail	Comments
5819.21	94.13	21.25	-3.23	112.15	Preview	H	180	352	122.2	-10.05	Pass	
5806.82	93.87	21.24	-3.24	111.87	Preview	H	180	0	122.2	-10.33	Pass	

PREVIEW DATA												
Freq. (MHz)	Raw (dBuV)	Cable (dB)	Factor (dB)	Level (dBuV/m)	Emission Type	Pol (H/V)	Ht (cm)	Az (deg)	Limit (dBuV/m)	Margin (dB)	Pass /Fail	Comments
5781.53	93.38	21.22	-3.26	111.34	Preview	H	180	0	122.2	-10.86	Pass	
5762.87	93.29	21.21	-3.28	111.22	Preview	H	180	0	122.2	-10.98	Pass	
5940.77	37.44	21.35	-3.14	55.64	Preview	V	100	264	68.2	-12.56	Pass	
5642.25	36.99	21.11	-3.37	54.73	Debug	H	101	352	68.2	-13.47	Pass	

Note: Preview data was measured using a peak detector to identify frequencies of interest for formal measurement. Formal data consist of all frequencies in the preview list within 6 dB of specification limit or the top six frequencies. Failure in preview data does not necessarily constitute failure in formal data.

4.2.2 Out of Band Emissions – Plots PAS2457-CC1 Antenna #9

OOBE_TM3.2_1C_20MBW_Band 46b_5320_26.5dBm total at AZRB ports_PAS2457-CC1

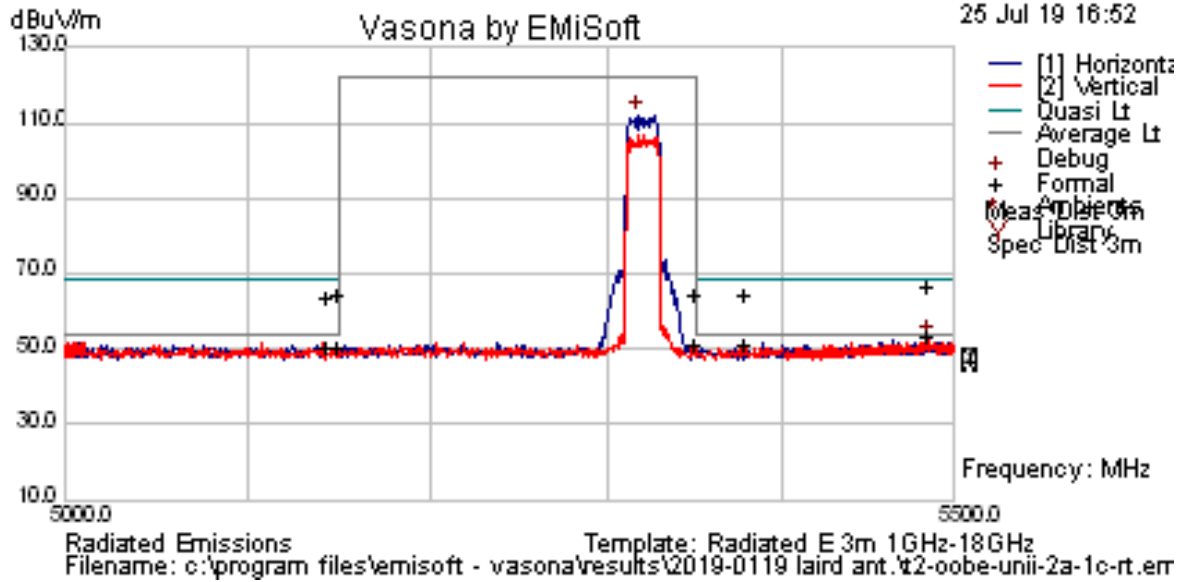

Results Title: Radiated E 5.0GHz-5.5GHz OOBE UNII-2
File Name: c:\program files\emisoft - vasona\results\2019-0119 laird ant.\t2-oobe-unii-2a-1c-rt.emi
Test Laboratory: GPCL AR5-MH 24C, 16%RH, 1008mB
Test Engineer: EEM
Software: Vasona by EMISoft, version 2.161
Equipment: Nokia Networks
EUT Details: AZRB with Laird Directional Panel Antenna. AZRB P/N 2205 B46 LAA-20170916, S/N X61W800212, PSU PN-474130A.102, SNU7182703949, W470003170-00010, Laird Directional Panel Antenna [Ant. PAS24527-CC1, S/N 1850010]; UNII-2A (High), 1 Carrier, 5320M [ETM3.2], 23.5 dBm. Carrier BW= 20 MHz
Configuration: Powered by 120VAC / 60Hz, Horn Antenna E1074, ESU-1G- E954 with 90dBuV Reference Level & Internal Attenuation 0dB, HP Preamp-E447 [Atten. E178+177] 10 dB & 6 dB Pad. Note: Additional 3 dB Pad [E175] was added to the Preamp Output and was accounted for in the Main Transducer Factor File] Preview BW (100 kHz RBW/ 3000 KHz VBW); Formal BW (1MHz RBW). UNII 2A [Single Carrier High OOBE Measurement.]: Project 2019-0119
Date: 2019-07-25 16:52:47

FORMAL DATA

Freq. (MHz)	Raw (dBuV)	Cable (dB)	Factor (dB)	Level (dBuV/m)	Emission Type	Pol (H/V)	Ht (cm)	Az (deg)	Limit (dBuV/m)	Margin (dB)	Pass /Fail	Comments
5486	29.1	23.81	-3.44	49.47	AvgMax	V	100	358	54	-4.53	Pass	NA
5486	42.38	23.81	-3.44	62.75	Peak	V	100	358	68.2	-5.45	Pass	
5350.61	27.39	23.78	-3.55	47.63	AvgMax	H	239	29	54	-6.37	Pass	
5379.42	27.15	23.79	-3.53	47.41	AvgMax	H	190	241	54	-6.59	Pass	
5143.62	27.07	23.73	-3.72	47.09	AvgMax	H	174	2	54	-6.91	Pass	
5149.94	26.94	23.74	-3.71	46.97	AvgMax	H	154	303	54	-7.03	Pass	

**FORMAL
 DATA**

Freq. (MHz)	Raw (dBuV)	Cable (dB)	Factor (dB)	Level (dBuV/m)	Emission Type	Pol (H/V)	Ht (cm)	Az (deg)	Limit (dBuV/m)	Margin (dB)	Pass /Fail	Comments
5142.34	26.89	23.73	-3.72	46.9	AvgMax	H	122	2	54	-7.1	Pass	
5350.61	40.56	23.78	-3.55	60.79	Peak	H	239	29	68.2	-7.41	Pass	
5379.42	40.52	23.79	-3.53	60.78	Peak	H	190	241	68.2	-7.42	Pass	
5149.94	40.46	23.74	-3.71	60.48	Peak	H	154	303	68.2	-7.72	Pass	
5142.34	40.34	23.73	-3.72	60.35	Peak	H	122	2	68.2	-7.85	Pass	
5143.62	40.12	23.73	-3.72	60.13	Peak	H	174	2	68.2	-8.07	Pass	

**PREVIEW
 DATA**

Freq. (MHz)	Raw (dBuV)	Cable (dB)	Factor (dB)	Level (dBuV/m)	Emission Type	Pol (H/V)	Ht (cm)	Az (deg)	Limit (dBuV/m)	Margin (dB)	Pass /Fail	Comments
5486	32.33	23.81	-3.44	52.7	Preview	V	102	0	54	-1.3	Pass	
5317.29	91.8	23.77	-3.58	112	Preview	H	102	0	122	-10	Pass	

Note: Preview data was measured using a peak detector to identify frequencies of interest for formal measurement. Formal data consist of all frequencies in the preview list within 6 dB of specification limit or the top six frequencies. Failure in preview data does not necessarily constitute failure in formal data.

OOBE_TM3.1a_4C_20MBW_Band 46a_5180/5200/5220/5240_29dBm total at AZRB ports_PAS2457-CC1

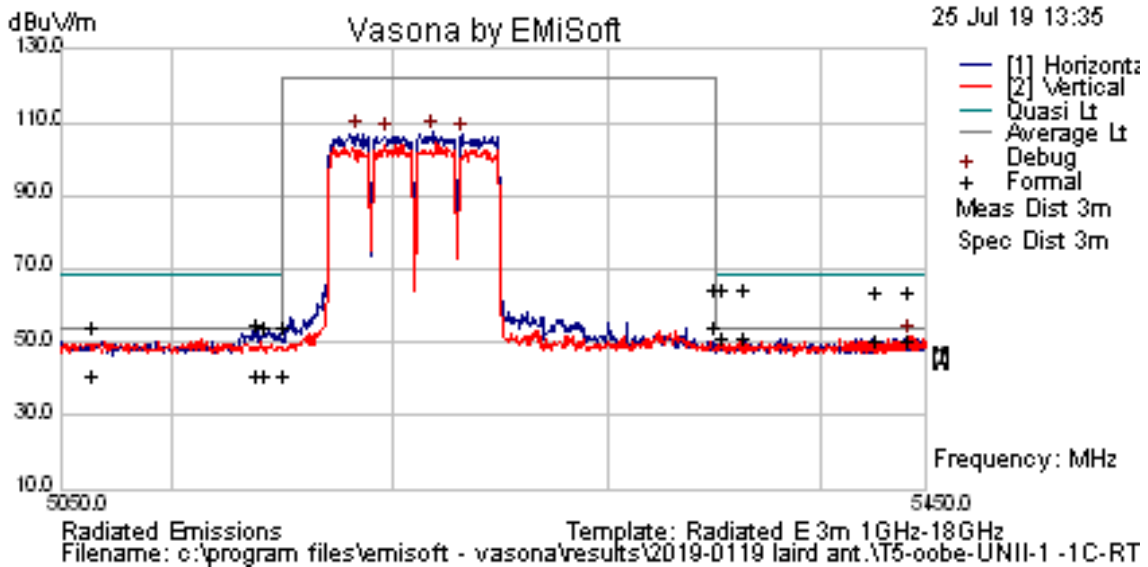

Results Title: Radiated E 3m 5.05GHz-5.45GHz
File Name: c:\program files\emisoft - vasona\results\2019-0119 laird ant.\T2-oobe-unii-2a-1c-rt.emi
Test Laboratory: GPCL AR5-MH 24C, 16%RH, 1008mB
Test Engineer: EEM
Test Software: Vasona by EMISoft, version 2.161
Equipment: Nokia Networks

EUT Details: AZRB with Laird Directional Panel Antenna. AZRB P/N 2205 B46 LAA-20170916, S/N X61W800212, PSU PN-474130A.102, SNU7182703949, W470003170-00010, Laird Directional Panel Antenna [Ant. PAS24527-CC1, S/N 1850010]; UNII-2A, 4C, 26 dBm. Carrier BW= 20 MHz

Configuration: Powered by 120VAC / 60Hz, Horn Antenna E1074, ESU-1G- E954 with 90dBuV Reference Level & Internal Attenuation 0dB, HP Preamp-E447 [Atten. E178+177] 10 dB & 6 dB Pad. Note: Additional 3 dB Pad [E175] was added to the Preamp Output and was accounted for in the Main Transducer Factor File]. Preview BW (100 kHz RBW/ 3000 KHz VBW); Formal BW (1MHz RBW).

Date: 2019-07-25 16:52:47

FORMAL DATA

Freq. (MHz)	Raw (dBuV)	Cable (dB)	Factor (dB)	Level (dBuV/m)	Emission Type	Pol (H/V)	Ht (cm)	Az (deg)	Limit (dBuV/m)	Margin (dB)	Pass /Fail	Comments
5350.03	30.47	23.78	-3.55	50.7	AvgMax	V	121	132	54	-3.3	Pass	
5353.2	27.14	23.78	-3.55	47.38	AvgMax	H	127	227	54	-6.62	Pass	
5364.26	27.1	23.78	-3.54	47.34	AvgMax	V	341	84	54	-6.66	Pass	
5442.71	26.5	23.8	-3.48	46.83	AvgMax	H	103	335	54	-7.17	Pass	
5364.26	40.7	23.78	-3.54	60.95	Peak	H	342	115	68.2	-7.25	Pass	
5427.27	26.4	23.8	-3.49	46.71	AvgMax	H	115	197	54	-7.29	Pass	
5350.03	40.31	23.78	-3.55	60.54	Peak	H	317	30	68.2	-7.66	Pass	
5353.2	40.25	23.78	-3.55	60.48	Peak	H	127	227	68.2	-7.72	Pass	
5427.27	39.8	23.8	-3.49	60.11	Peak	H	115	197	68.2	-8.09	Pass	
5442.71	39.69	23.8	-3.48	60.01	Peak	V	324	358	68.2	-8.19	Pass	
5064.07	17.37	23.72	-3.79	37.3	AvgMax	V	322	360	54	-16.7	Pass	
5138.23	17.19	23.73	-3.72	37.2	AvgMax	H	234	184	54	-16.8	Pass	
5141.73	17.17	23.73	-3.72	37.19	AvgMax	H	161	338	54	-16.81	Pass	
5149.98	17.16	23.74	-3.71	37.18	AvgMax	V	140	0	54	-16.82	Pass	
5138.23	31.07	23.73	-3.72	51.08	Peak	V	150	296	68.2	-17.12	Pass	
5064.07	30.96	23.72	-3.79	50.89	Peak	H	125	169	68.2	-17.31	Pass	
5141.73	30.76	23.73	-3.72	50.77	Peak	V	187	173	68.2	-17.43	Pass	
5149.98	30.66	23.74	-3.71	50.69	Peak	H	364	339	68.2	-17.51	Pass	

PREVIEW DATA

Freq. (MHz)	Raw (dBuV)	Cable (dB)	Factor (dB)	Level (dBuV/m)	Emission Type	Pol (H/V)	Ht (cm)	Az (deg)	Limit (dBuV/m)	Margin (dB)	Pass /Fail	Comments
5442.71	31.19	23.8	-3.48	51.51	Preview	V	102	180	54	-2.49	Pass	
5218.13	87.25	23.75	-3.66	107.34	Preview	H	102	0	122.2	-14.86	Pass	

Note: Preview data was measured using a peak detector to identify frequencies of interest for formal measurement. Formal data consist of all frequencies in the preview list within 6 dB of specification limit or the top six frequencies. Failure in preview data does not necessarily constitute failure in formal data.

5. FCC Section 15.407(b) (1-8), 15.205 & 15.209 - Unwanted Radiated Spurious Emissions

5.1 Unwanted Radiated Spurious Emissions

Spurious Emissions were investigated over the frequency range of 30MHz to the 40GHz per 15.33.

Per KDB 789033 D02 guidance II.G.3.b, “The unwanted emission limits in both the restricted and non-restricted bands are based on radiated measurements; however, as an alternative, antenna-port conducted measurements in conjunction with cabinet emissions tests will be permitted to demonstrate compliance.”

5.2 Unwanted Radiated Spurious Emissions Limits

The Limits of FCC 15.109 Class B, 15.209 and 15.407 were given below, where the conversion between the EIRP and electrical field strength and the restricted bands of operation specified in FCC 15.205(a) were provided in above section. The FCC 15.109 Class B limits are identical to the 15.209 limits between 30MHz and 30GHz for the EUT operating in UNII bands.

FCC 15.109 Class B and 15.209 Radiated Emissions Limits

Frequency (MHz)	Field Strength at 3m (dB uV/m)		RBW (kHz)	Detector
	FCC 15.109 Class B	FCC 15.209		
10 - 30		49.5	9	QP
30 - 88	40	40		
88 - 216	43.5	43.5		
216 - 230	46	46	120	QP
230 - 960	46	46		
960 - 1000	54	54		
1000 - 3000	54	54		Ave.
	74	74	1000	Peak
> 3000 - 5 f_c	54	54		Ave.
	74	74	1000	Peak
5 f_c - 10 f_c / 40GHz		54		Ave.
		74	1000	Peak

Combined Worst Radiated Emission Limits per 15.407 UNII-1/2/3, 15.209 and 15.109 at 3m

Frequency (MHz)	E (dBuV/m)*	RBW (kHz)	Detector
30 - 88	40/63.7	120kHz	QP/Peak
88 - 216	43.5/63.7		
216 - 960	46/63.7		
960 - 1000	54/63.7		
1G - 40G in Restricted Bands	54/68.2	1000	Ave/Peak
1G - 40G in Non-Restricted Bands	68.2	1000	Peak

*Per KDB 789033 D02, the ground reflection 4.7dB was included for frequencies below 1GHz.

The radiated spurious emissions of the EUT with the directional BA-AIO3O3T3T3VJX65F-06 antenna #8 in the frequency range of 1GHz-26GHz was evaluated for 1) 1x20MHz at 5180MHz with Q/16QAM and 30dBm total power and 2) 4x20MHz with Q/16QAM and 29dBm total power configurations.

The recommendations of ANSI C63.10 were followed for EUT testing setup and cabling. The measurement guidance given in KDB 789033 D02 was followed. The emissions were maximized by rotating the turntable 360° and moving the receiving antenna height to scan and capture the emissions from the EUT.

The unwanted radiated spurious emissions measured met the FCC 15.407 and 15.209 requirements for intentional radiators and the FCC 15.109 Class B requirements for unintentional radiators.

NOTES: 1) The plots with the minimum margins in each frequency range evaluated were used in this report. The full suite of raw data resides at the MH, New Jersey location. 2) "NA" (Not Applicable) in the tables of Formal Data below was due to the fact that only the unwanted emissions in the restricted band above 1GHz are subject to the average 54 dBuV/m limit per FCC 15.205 and 15.209.

5.2.1 Radiated Spurious Emissions – Plots BA-AIO3O3T3T3VJX65F-06 Antenna #8

Spurious_TM3.2_1C_20MBW_5180_30dBm, 1-26GHz_BA-AIO3O3T3T3VJX65F-06

(Note: For carrier related emissions, the limit for peak detection is 68.2 dBuV/m; for emissions which are not related to carriers, the limit for peak detection is 74 dBuV/m)

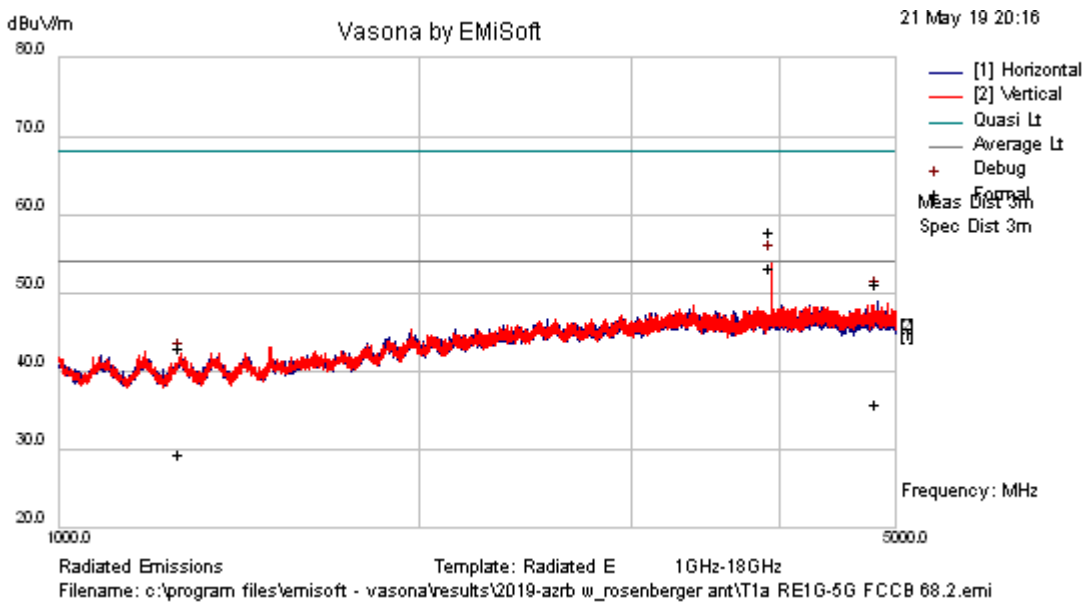

Results Title:	Radiated E 1GHz-18GHz
File Name:	c:\program files\emisoft - vasona\results\2019-azrb_w_rosenberger ant\T1a RE1G-5G FCCB 68.2.emi
Test Laboratory:	AR4-MH, 24C, 44% 977mB
Test Engineer:	GM/MJS
Test Software:	Vasona by EMISoft, version 2.161
Equipment:	Nokia
EUT Details:	AZRB PN: 474510A.101, S/N: 1M181319958 with Rosenberger Base Station Antenna PN: BA-AIO3O3T3T3VJX65F-06, SN: RAPAFO1183927707, Power Supply Module PN: 474130A.102, S/N: U7182703949, Modulation TM3.2, 27dBm, 1C transmitting @ 5180MHz, 20MHz BW.

Configuration:	Powered by 120Vac, Tested to FCC Class B, RE 1.0G-5GHz, @ 3-Meters Horn Antenna E1073, ESU IH69, Pre-Amp E1356, Notch Filter E1365. Internal attenuation 0dB, Preview BW (1000 kHz RBW/ 3000 KHz VBW); Formal BW (1MHz RBW).
Date:	2019-05-21 20:16:49

FORMAL DATA												
Freq. (MHz)	Raw (dBuV)	Cable (dB)	Factor (dB)	Level (dBuV/m)	Emission Type	Pol (H/V)	Ht (cm)	Az (deg)	Limit (dBuV/m)	Margin (dB)	Pass /Fail	Comments
3932.12	48.45	5.2	-3.06	50.59	AvgMax	V	103	0	54	-3.41	Pass	
3932.12	53.05	5.2	-3.06	55.19	Peak	V	103	0	68.2	-13.01	Pass	
4817.95	45.7	5.46	-2.63	48.54	Peak	H	264	223	68.2	-19.66	Pass	
4817.95	30.23	5.46	-2.63	33.06	AvgMax	H	264	223	54	-20.94	Pass	
1261.83	35.17	1.76	-10.1	26.85	AvgMax	H	332	233	54	-27.15	Pass	NA
1261.83	48.67	1.76	-10.1	40.34	Peak	H	332	233	68.2	-27.86	Pass	

PREVIEW DATA

Freq. (MHz)	Raw (dBuV)	Cable (dB)	Factor (dB)	Level (dBuV/m)	Emission Type	Pol (H/V)	Ht (cm)	Az (deg)	Limit (dBuV/m)	Margin (dB)	Pass /Fail	Comments
3931.54	51.61	5.2	-3.06	53.75	Preview	V	100	0	54	-0.25	Pass	
4817.95	46.1	5.46	-2.63	48.93	Preview	H	280	220	54	-5.07	Pass	
1261.83	49.38	1.76	-10.1	41.06	Debug	H	98	352	54	-12.94	Pass	

Note: Preview data was measured using a peak detector to identify frequencies of interest for formal measurement. Formal data consist of all frequencies in the preview list within 6 dB of specification limit or the top six frequencies. Failure in preview data does not necessarily constitute failure in formal data.

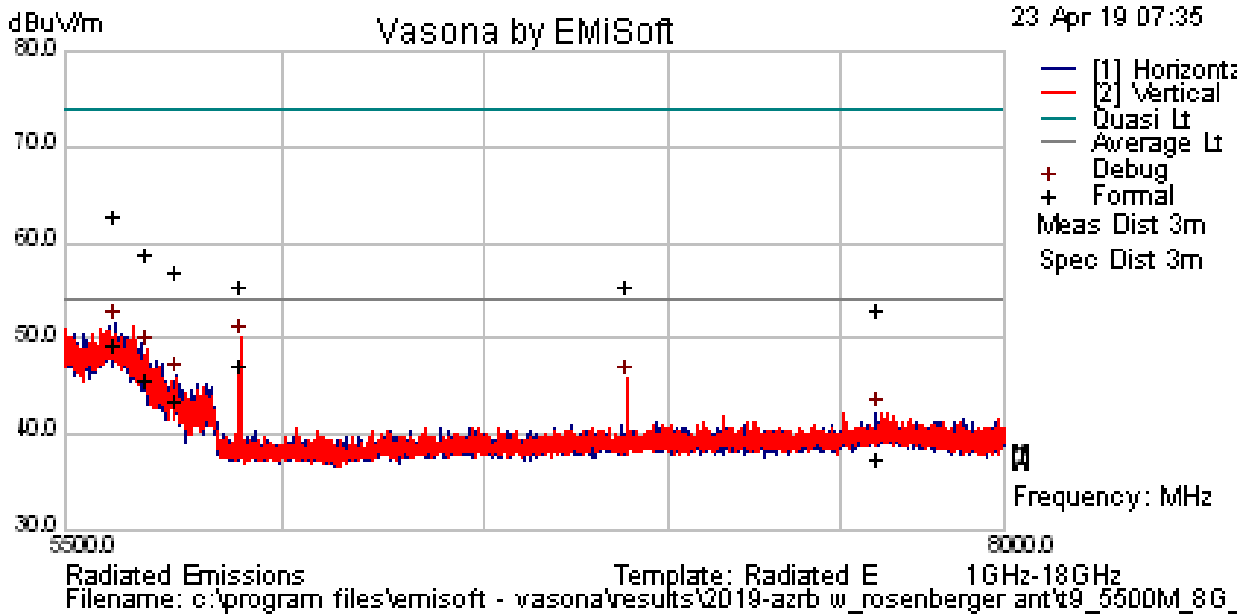

Results Title:	Radiated E 1GHz-18GHz
File Name:	c:\program files\emisoft - vasona\results\2019-azrb w_rosenberger ant\t9_5500M_8G_notch_filt_formal.emi

Test Laboratory:	AR4-MH, 24C, 44% 977mB
Test Engineer:	NPA
Test Software:	Vasona by EMISoft, version 2.161
Equipment:	Nokia
EUT Details:	2019-0082 AZRB PN: 474510A.101, S/N: 1M181319958 with Rosenberger Base Station Antenna PN: BA-AIO3O3T3T3VJX65F-06, SN: RAPAFO1183927707, Power Supply Module PN: 474130A.102, S/N: U7182703949, Modulation ETM3.2, 27dBm, 1C transmitting @ 5180MHz, 20MHz BW L, Powered by 120Vac,
Configuration:	Radiated Emmissions 5.5GHz - 8GHz, FCC Class B Limit, Ant E1073, RCVR ESU IH69, Pre-Amp E1356, Notch Filter E1400 with E1403 factors, Ref Lvl 80dB, Int attn 10dB, Preview RBW 100kHz Formal RBW 1MHz, 3m measurement distance, straight bore, no tilt
Date:	2019-04-23 07:35:02

FORMAL DATA

Freq. (MHz)	Raw (dBuV)	Cable (dB)	Factor (dB)	Level (dBuV/m)	Emission Type	Pol (H/V)	Ht (cm)	Az (deg)	Limit (dBuV/m)	Margin (dB)	Pass /Fail	Comments
5611.3	42.92	6.97	-1.98	47.9	AvgMax	H	167	348	54	-6.1	Pass	*
5898.24	40.41	7.02	-1.74	45.69	AvgMax	V	268	342	54	-8.31	Pass	*
5682.49	39.14	6.98	-1.92	44.2	AvgMax	V	227	28	54	-9.8	Pass	*
5749.67	36.93	6.99	-1.86	42.06	AvgMax	H	241	0	54	-11.94	Pass	*
5611.3	56.23	6.97	-1.98	61.21	Peak	H	167	348	68.2	-6.99	Pass	
5682.49	52.2	6.98	-1.92	57.26	Peak	V	227	28	68.2	-10.94	Pass	
5749.67	50.25	6.99	-1.86	55.38	Peak	H	241	0	68.2	-12.84	Pass	
6881.29	47.6	7.27	-0.87	53.99	Peak	V	142	293	68.2	-14.21	Pass	
5898.24	48.62	7.02	-1.74	53.91	Peak	V	268	342	68.2	-14.29	Pass	
7604.8	44.63	7.78	-1	51.41	Peak	H	351	271	68.2	-16.79	Pass	
7604.8	29.13	7.78	-1	35.91	AvgMax	H	351	271	54	-18.09	Pass	

- Not related to Transmitter.

PREVIEW DATA

Freq. (MHz)	Raw (dBuV)	Cable (dB)	Factor (dB)	Level (dBuV/m)	Emission Type	Pol (H/V)	Ht (cm)	Az (deg)	Limit (dBuV/m)	Margin (dB)	Pass /Fail	Comments
5611.3	46.63	6.97	-1.98	51.61	Preview	H	180	352	54	-2.39	Pass	
5898.32	44.68	7.02	-1.74	49.97	Preview	V	100	352	54	-4.03	Pass	
5682.49	43.77	6.98	-1.92	48.83	Preview	V	200	22	54	-5.17	Pass	
5749.67	40.85	6.99	-1.86	45.98	Preview	H	180	0	54	-8.02	Pass	
6881.72	39.39	7.27	-0.87	45.79	Preview	V	200	0	54	-8.21	Pass	
7604.8	35.46	7.78	-1	42.25	Preview	H	280	198	54	-11.75	Pass	

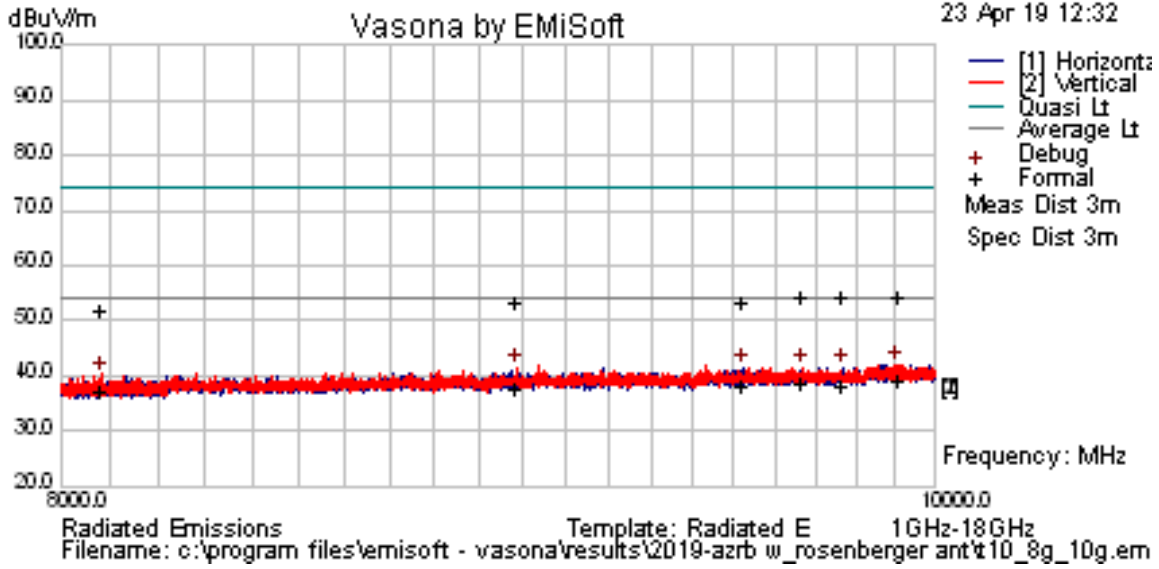

Results Title:	Radiated E 1GHz-18GHz
File Name:	c:\program files\emisoft - vasona\results\2019-azrb w_rosenberger ant\10a_RE8g_10G.emi
Test Laboratory:	AR4-MH, 24C, 44% 977mB
Test Engineer:	GM/MJS
Test Software:	Vasona by EMISoft, version 2.161
Equipment:	Nokia
EUT Details:	2019-0082 AZRB PN: 474510A.101, S/N: 1M181319958 with Rosenberger Base Station Antenna PN: BA-AIO3O3T3T3VJX65F-06, SN: RAPAFO1183927707, Power Supply Module PN: 474130A.102, S/N: U7182703949, Modulation ETM3.2, 27dBm, 1C transmitting @ 5180MHz, 20MHz BW L, Powered by 120Vac,
Configuration:	Radiated Emissions 8GHz - 10GHz, FCC Class B Limit, Ant E1073, RCVR ESU IH69, Pre-Amp E1356, High Pass Filter E1378. Ref Lvl 80dB, Int attn 10dB, Preview RBW 100kHz Formal RBW 1MHz, 3m measurement distance, straight bore, no tilt
Date:	2019-05-21 22:18:04

FORMAL DATA												
Freq. (MHz)	Raw (dBuV)	Cable (dB)	Factor (dB)	Level (dBuV/m)	Emission Type	Pol (H/V)	Ht (cm)	Az (deg)	Limit (dBuV/m)	Margin (dB)	Pass /Fail	Comments
9666.09	45.09	7.08	-0.25	51.93	Peak	V	179	195	68.2	-16.27	Pass	
9906.3	44.62	7.1	0.04	51.76	Peak	V	324	32	68.2	-16.44	Pass	
9766.97	44.76	7.09	-0.13	51.72	Peak	H	213	191	68.2	-16.48	Pass	
9520.15	44.5	7.08	-0.43	51.15	Peak	H	272	229	68.2	-17.05	Pass	
9906.3	29.41	7.1	0.04	36.54	Average	V	324	32	54	-17.46	Pass	NA
8986.06	44.43	7.04	-0.74	50.73	Peak	V	173	133	68.2	-17.47	Pass	
9666.09	29.35	7.08	-0.25	36.18	Average	V	179	195	54	-17.82	Pass	NA
9520.15	29.07	7.08	-0.43	35.71	Average	H	272	229	54	-18.29	Pass	NA
9766.97	28.75	7.09	-0.13	35.71	Average	H	213	191	54	-18.29	Pass	NA
8986.06	29.19	7.04	-0.74	35.5	Average	V	173	133	54	-18.5	Pass	NA
8083.28	43.7	6.64	-1.07	49.27	Peak	V	208	359	68.2	-18.93	Pass	
8083.28	29.44	6.64	-1.07	35.01	Average	V	208	359	54	-18.99	Pass	

PREVIEW DATA												
Freq. (MHz)	Raw (dBuV)	Cable (dB)	Factor (dB)	Level (dBuV/m)	Emission Type	Pol (H/V)	Ht (cm)	Az (deg)	Limit (dBuV/m)	Margin (dB)	Pass /Fail	Comments
9905.27	34.93	7.1	0.04	42.07	Preview	V	280	132	54	-11.93	Pass	
8083.28	34.6	6.64	-1.07	40.17	Debug	V	98	352	54	-13.83	Pass	
8986.06	35.22	7.04	-0.74	41.52	Debug	V	98	352	54	-12.48	Pass	
9666.09	34.7	7.08	-0.25	41.53	Debug	V	98	352	54	-12.47	Pass	
9766.97	34.47	7.09	-0.13	41.43	Debug	H	98	352	54	-12.57	Pass	
9520.15	34.9	7.08	-0.43	41.54	Debug	H	98	352	54	-12.46	Pass	

Note: Preview data was measured using a peak detector to identify frequencies of interest for formal measurement. Formal data consist of all frequencies in the preview list within 6 dB of specification limit or the top six frequencies. Failure in preview data does not necessarily constitute failure in formal data.

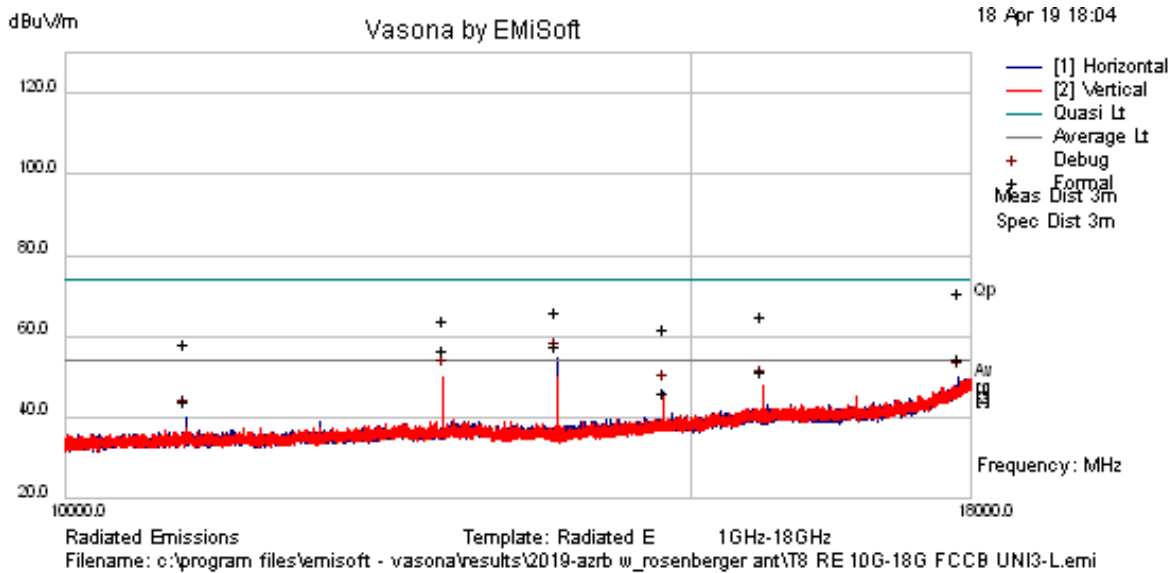

Results Title:	Radiated E 1GHz-18GHz
File Name:	c:\program files\emisoft - vasona\results\2019-azrb w_rosenberger ant\T8a RE 10G-18G FCCB UNI3-L.emi
Test Laboratory:	AR4-MH, 24C, 44% 977mB
Test Engineer:	GM/MJS
Test Software:	Vasona by EMISoft, version 2.161
Equipment:	Nokia
EUT Details:	AZRB PN: 474510A.101, S/N: 1M181319958 with Rosenberger Base Station Antenna PN: BA-AIO3O3T3T3VJX65F-06, SN: RAPAF01183927707, Power Supply Module PN: 474130A.102, S/N: U7182703949, Modulation ETM3.2, 27dBm, 1C transmitting @ 5180MHz, 20MHz BW L,
Configuration:	Powered by 120Vac, Tested to FCC Class B, RE 10GH-18GHz, (OOBE) @ 3-Meters Horn Antenna E1073, ESU IH69, Pre-Amp E1356, HPF E1378. Internal attenuation 10dB, Preview BW (30 kHz RBW/ 3000 KHz VBW); Formal BW (1MHz RBW). Radiated Emissions; FCC Pt15 Class B, 3 Meters
Date:	2019-05-21 22:10:20

FORMAL DATA												
Freq. (MHz)	Raw (dBuV)	Cable (dB)	Factor (dB)	Level (dBuV/m)	Emission Type	Pol (H/V)	Ht (cm)	Az (deg)	Limit (dBuV/m)	Margin (dB)	Pass /Fail	Comments
13762.4	41.27	7.98	4.13	53.38	Average	H	99	324	54	-0.62	Pass	*
12779.5	40.95	7.42	3.95	52.32	Average	V	182	295	54	-1.68	Pass	*
17855.1	44.76	14.54	7.11	66.42	Peak	H	380	12	68.2	-1.78	Pass	
17855.1	28.2	14.54	7.11	49.85	Average	H	380	12	54	-4.15	Pass	
13762.4	49.55	7.98	4.13	61.66	Peak	H	99	324	68.2	-6.54	Pass	
15729	32.62	9.56	4.73	46.91	Average	V	174	313	54	-7.09	Pass	
15729	46.03	9.56	4.73	60.32	Peak	V	174	313	68.2	-7.88	Pass	
12779.5	48.27	7.42	3.95	59.65	Peak	V	182	295	68.2	-8.55	Pass	
14746.1	44.89	8.27	4.45	57.61	Peak	H	168	341	68.2	-10.59	Pass	
14746.1	29.04	8.27	4.45	41.76	Average	H	168	341	54	-12.24	Pass	NA
10813.4	31.05	7.22	1.32	39.58	Average	H	185	234	54	-14.42	Pass	
10813.4	45.01	7.22	1.32	53.55	Peak	H	185	234	68.2	-14.65	Pass	

* Not related to Transmitter on/off

PREVIEW DATA												
Freq. (MHz)	Raw (dBuV)	Cable (dB)	Factor (dB)	Level (dBuV/m)	Emission Type	Pol (H/V)	Ht (cm)	Az (deg)	Limit (dBuV/m)	Margin (dB)	Pass /Fail	Comments
13762.9	42.29	7.98	4.13	54.4	Preview	H	100	0	54	0.4	Fail	
12779.5	38.48	7.42	3.95	49.85	Preview	V	100	225	54	-4.15	Pass	
17855.1	28.16	14.54	7.11	49.81	Preview	H	380	180	54	-4.19	Pass	
15729	33.41	9.56	4.73	47.7	Preview	V	200	315	54	-6.3	Pass	
14745.6	33.61	8.27	4.45	46.32	Preview	H	100	315	54	-7.68	Pass	
10813.4	31.63	7.22	1.32	40.16	Preview	H	100	225	54	-13.84	Pass	

Note: Preview data was measured using a peak detector to identify frequencies of interest for formal measurement. Formal data consist of all frequencies in the preview list within 6 dB of specification limit or the top six frequencies. Failure in preview data does not necessarily constitute failure in formal data.

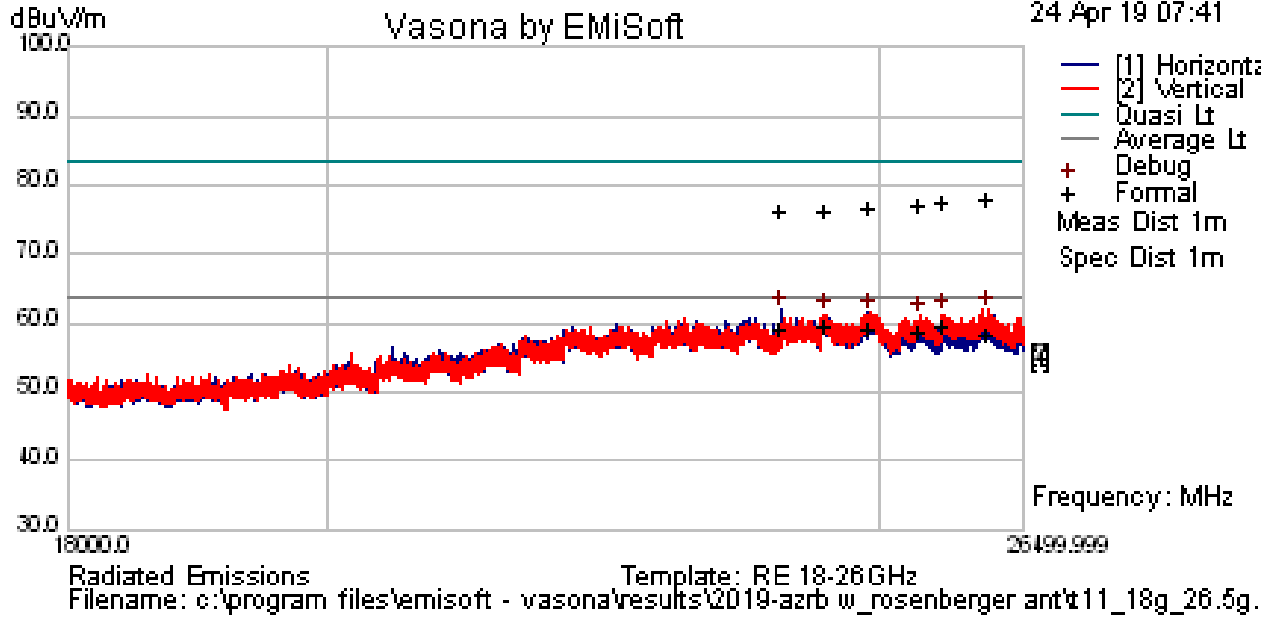

Results Title:	RE 18-26GHz
File Name:	c:\program files\emisoft - vasona\results\2019-azrb w_rosenberger ant\t11_18g_26.5g.emi
Test Laboratory:	AR4-MH, 24C, 44% 977mB
Test Engineer:	JY
Test Software:	Vasona by EMiSoft, version 2.161
Equipment:	Nokia
EUT Details:	2019-0082 AZRB PN: 474510A.101, S/N: 1M181319958 with Rosenberger Base Station Antenna PN: BA-AIO3O3T3T3VJX65F-06, SN: RAPAF01183927707, Power Supply Module PN: 474130A.102, S/N: U7182703949, Modulation ETM3.2, 27dBm, 1C transmitting @ 5180MHz, 20MHz BW L, Powered by 120Vac,
Configuration:	Radiated Emissions 18GHz - 26.5GHz, FCC Class B Limit, Ant E520, RCVR ESU IH69, Pre-Amp E1356, High Pass Filter E1212. Ref Lvl 80dB, Int attn 10dB, Preview RBW 100kHz Formal RBW 1MHz, 1m measurement distance, straight bore, no tilt
Date:	2019-04-24 07:41:42

FORMAL DATA

Freq. (MHz)	Raw (dBuV)	Cable (dB)	Factor (dB)	Level (dBuV/m)	Emission Type	Pol (H/V)	Ht (cm)	Az (deg)	Limit (dBuV/m)	Margin (dB)	Pass /Fail	Comments
24445.5	27.69	17.89	11.94	57.52	AvgMax	H	128	30	63.5	-5.98	Pass	NA
25654.4	26.41	17.6	13.35	57.37	AvgMax	V	166	123	63.5	-6.13	Pass	NA
24034.7	27.19	18.15	11.66	57	AvgMax	H	187	239	63.5	-6.5	Pass	NA
24912.1	27.1	17.6	12.25	56.95	AvgMax	V	154	241	63.5	-6.55	Pass	NA
25404.4	26.08	17.58	12.95	56.62	AvgMax	V	113	248	63.5	-6.88	Pass	NA
26127.5	24.99	17.17	14.17	56.32	AvgMax	V	118	91	63.5	-7.18	Pass	NA
26127.5	44.8	17.17	14.17	76.14	Peak	V	118	91	77.7	-1.56	Pass	
25654.4	44.69	17.6	13.35	75.65	Peak	V	166	123	77.7	-2.05	Pass	
25404.4	44.53	17.58	12.95	75.06	Peak	V	113	248	77.7	-2.64	Pass	
24912.1	44.87	17.6	12.25	74.72	Peak	V	154	241	77.7	-2.98	Pass	
24445.5	44.61	17.89	11.94	74.43	Peak	H	128	30	77.7	-3.27	Pass	

FORMAL DATA

Freq. (MHz)	Raw (dBuV)	Cable (dB)	Factor (dB)	Level (dBuV/m)	Emission Type	Pol (H/V)	Ht (cm)	Az (deg)	Limit (dBuV/m)	Margin (dB)	Pass /Fail	Comments
24034.7	44.42	18.15	11.66	74.23	Peak	H	187	239	77.7	-3.47	Pass	

PREVIEW DATA

Freq. (MHz)	Raw (dBuV)	Cable (dB)	Factor (dB)	Level (dBuV/m)	Emission Type	Pol (H/V)	Ht (cm)	Az (deg)	Limit (dBuV/m)	Margin (dB)	Pass /Fail	Comments
26130.7	30.56	17.16	14.18	61.9	Preview	V	200	242	63.5	-1.6	Pass	
24034.7	31.78	18.15	11.66	61.59	Debug	H	103	352	63.5	-1.91	Pass	
24445.5	31.36	17.89	11.94	61.19	Debug	H	103	352	63.5	-2.31	Pass	
24912.1	31.49	17.6	12.25	61.34	Debug	V	103	352	63.5	-2.16	Pass	
25654.4	30.31	17.6	13.35	61.26	Debug	V	103	352	63.5	-2.24	Pass	
25404.4	30.27	17.58	12.95	60.81	Debug	V	103	352	63.5	-2.69	Pass	

Note: Preview data was measured using a peak detector to identify frequencies of interest for formal measurement. Formal data consist of all frequencies in the preview list within 6 dB of specification limit or the top six frequencies. Failure in preview data does not necessarily constitute failure in formal data.

Spurious_TM3.2_4C_20MBW_5765/5785/5805/5825_29dBm, 30MHz-18GHz_BA-AIO3O3T3T3VJX65F-06

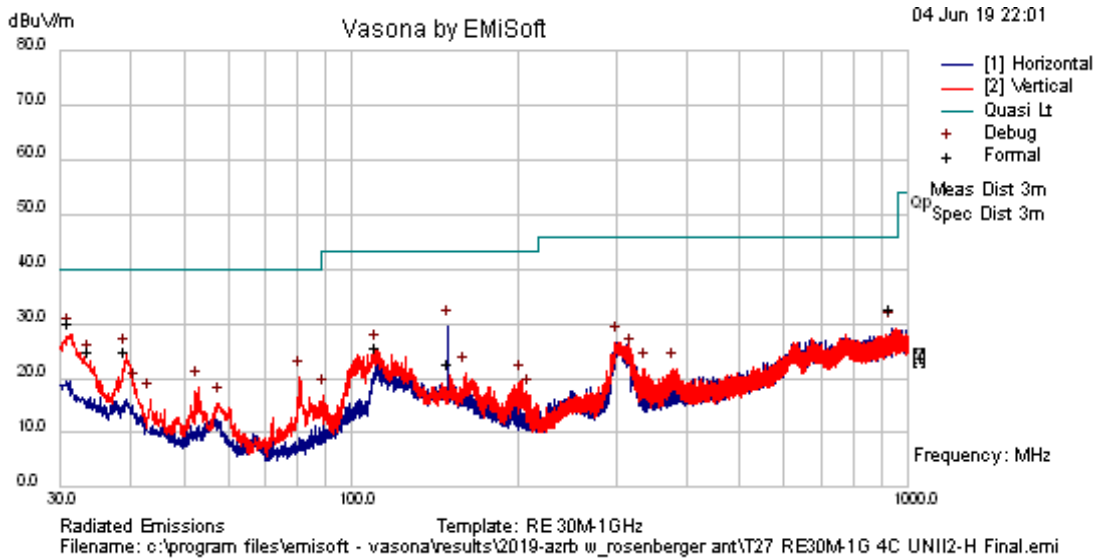

Results Title:	RE 30M-1GHz
File Name:	c:\program files\emisoft - vasona\results\2019-azrb w_rosenberger ant\T27 RE30M-1G 4C UNII2-H Final.emi
Test Laboratory:	AR4-MH, 24C, 44% 977mB
Test Engineer:	MJS
Test Software:	Vasona by EMIsoft, version 2.161
Equipment:	Nokia
EUT Details:	2019-0082 AZRB PN: 474510A.101, S/N: 1M181319958 with Rosenberger Base Station Antenna PN: BA-AIO3O3T3T3VJX65F-06, SN: RAPAFO1183927707, Power Supply Module PN: 474130A.102, S/N: U7182703949, Modulation ETM3.1, ETM3.1a, 26dBm, 4C-UNII-2-H - Transmitting @ 5660M, 5680M, 5700M, 5720MHz, 80MHz BW H, Powered by 120VAC. Tx Back on, full scan with formals.

Configuration :	Radiated Emissions RE 30M-1GHz, FCC Class B Limit, Ant E766 with 4dB pad, RCVR ESU- E954, Pre-Amp E813, Ref Lvl 80dB, Int attn 10dB, Preview RBW default Formal RBW default, 3M measurement distance.
Date:	2019-06-04 22:01:53

FORMAL DATA												
Freq. (MHz)	Raw (dBuV)	Cable (dB)	Factor (dB)	Level (dBuV/m)	Emission Type	Pol (H/V)	Ht (cm)	Az (deg)	Limit (dBuV/m)	Margin (dB)	Pass /Fail	Comments
31.091	36.21	0.5	-9.93	26.78	Peak	V	98	71	40	-13.22	Pass	
935.745	28.81	2.84	-1.94	29.71	Peak	H	118	46	46	-16.29	Pass	
39.186	35.4	0.55	-14.2	21.76	Peak	V	98	344	40	-18.24	Pass	
33.871	32.56	0.52	-11.4	21.65	Peak	V	123	84	40	-18.35	Pass	
111.123	33.2	0.98	-11.8	22.41	Peak	V	274	251	43.5	-21.09	Pass	
149.452	27.47	1.13	-9.15	19.45	Peak	H	180	227	43.5	-24.05	Pass	

PREVIEW DATA												
Freq. (MHz)	Raw (dBuV)	Cable (dB)	Factor (dB)	Level (dBuV/m)	Emission Type	Pol (H/V)	Ht (cm)	Az (deg)	Limit (dBuV/m)	Margin (dB)	Pass /Fail	Comments
31.0769	37.51	0.5	-9.92	28.09	Preview	V	100	0	40	-11.91	Pass	
149.538	37.59	1.13	-9.15	29.57	Preview	H	380	0	43.5	-13.93	Pass	
39.3077	38.03	0.55	-14.3	24.33	Preview	V	100	315	40	-15.67	Pass	
935.846	28.37	2.84	-1.94	29.27	Preview	H	380	270	46	-16.73	Pass	
33.8462	34.1	0.52	-11.4	23.21	Preview	V	100	45	40	-16.79	Pass	
111.154	35.86	0.98	-11.8	25.07	Preview	V	180	270	43.5	-18.43	Pass	
300.923	37.48	1.46	-12.3	26.65	Preview	H	100	315	46	-19.35	Pass	
80.7692	38.33	0.83	-18.8	20.38	Preview	V	100	225	40	-19.62	Pass	
53.0769	36.92	0.64	-19.2	18.39	Preview	V	100	45	40	-21.61	Pass	
319.462	34.56	1.55	-11.9	24.27	Preview	V	180	180	46	-21.73	Pass	
41	32.56	0.56	-15.1	18.05	Preview	V	100	315	40	-21.95	Pass	
160	30.4	1.16	-10.7	20.91	Preview	V	100	315	43.5	-22.59	Pass	
202.154	33.69	1.28	-15.4	19.56	Preview	V	100	315	43.5	-23.94	Pass	
43.3846	31.65	0.58	-16.2	16.05	Preview	V	100	270	40	-23.95	Pass	
338.308	31.65	1.64	-11.5	21.79	Preview	V	180	135	46	-24.21	Pass	
380.077	30.17	1.81	-10.4	21.61	Preview	V	180	135	46	-24.39	Pass	
57.9231	34.71	0.68	-20	15.35	Preview	V	100	90	40	-24.65	Pass	
208.692	31	1.29	-15.3	16.96	Preview	V	100	315	43.5	-26.54	Pass	
89.1538	32.99	0.88	-16.9	16.92	Preview	V	100	315	43.5	-26.58	Pass	

Note: Preview data was measured using a peak detector to identify frequencies of interest for formal measurement. Formal data consist of all frequencies in the preview list within 6 dB of specification limit or the top six frequencies. Failure in preview data does not necessarily constitute failure in formal data.

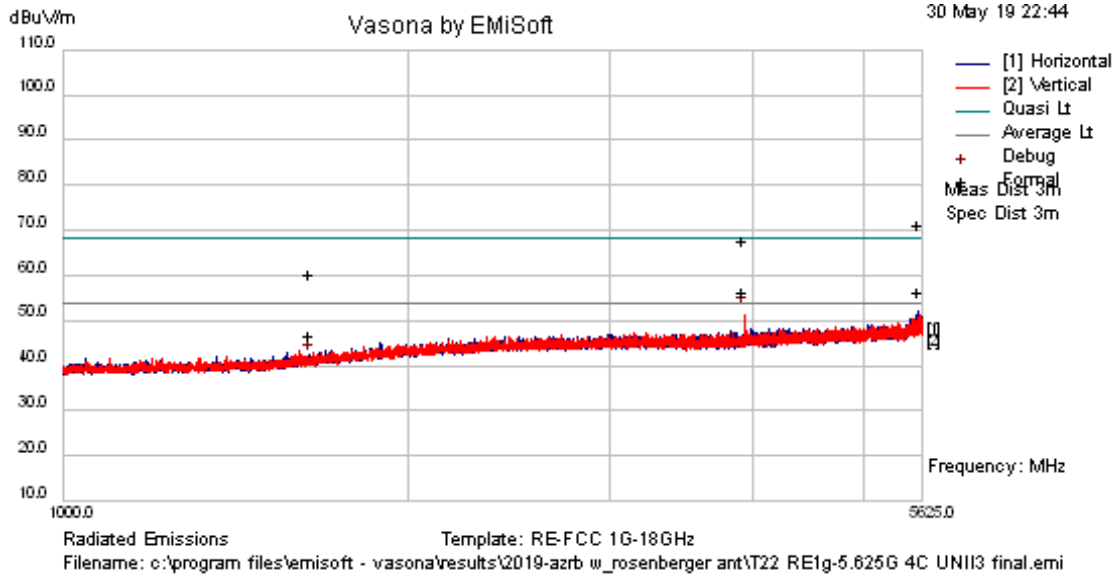

Results Title:	RE-FCC 1G-18GHz
File Name:	c:\program files\emisoft - vasona\results\2019-azrb w_rosenberger ant\T22 RE1g-5.625G 4C UNII3 final.emi
Test Laboratory:	AR4-MH, 24C, 44% 977mB
Test Engineer:	MJS
Test Software:	Vasona by EMISoft, version 2.161
Equipment:	Nokia
EUT Details:	2019-0082 AZRB PN: 474510A.101, S/N: 1M181319958 with Rosenberger Base Station Antenna PN: BA-AIO3O3T3T3VJX65F-06, SN: RAPAF01183927707, Power Supply Module PN: 474130A.102, S/N: U7182703949, Modulation ETM3.2, 26dBm, 4C-UNII-3 - Transmitting @ 5765M, 5785M, 5805M, 5825MHz, 80MHz BW L, Powered by 120VAC. Tx Back on, full scan with formals.
Configuration:	Radiated Emissions 1GHz - 5.625GHz, FCC Class B Limit, Ant E1073, RCVR ESU-1G IH69, Pre-Amp E447, 10dB pad-E177 and 6dB pad- E176, Ref Lvl 110dB, Int attn 10dB, Preview RBW 30kHz Formal RBW 1MHz, 3m measurement distance, straight bore, no tilt.
Date:	2019-05-30 22:44:19

FORMAL DATA												
Freq. (MHz)	Raw (dBuV)	Cable (dB)	Factor (dB)	Level (dBuV/m)	Emission Type	Pol (H/V)	Ht (cm)	Az (deg)	Limit (dBuV/m)	Margin (dB)	Pass /Fail	Comments
5582.63	49.29	21.07	-3.42	66.94	Peak	H	201	344	68.2	-1.26	Pass	
3932.17	37	19.72	-4.71	52.01	Average	V	147	0	54	-1.99	Pass	
5582.63	34.31	21.07	-3.42	51.96	Average	H	201	344	54	-2.04	Pass	NA
3932.17	48.28	19.72	-4.71	63.3	Peak	V	147	0	68.2	-4.9	Pass	
1647.35	33.99	18.47	-9.94	42.52	Average	H	224	317	54	-11.48	Pass	NA
1647.35	47.47	18.47	-9.94	56	Peak	H	224	317	68.2	-12.2	Pass	

PREVIEW DATA												
Freq. (MHz)	Raw (dBuV)	Cable (dB)	Factor (dB)	Level (dBuV/m)	Emission Type	Pol (H/V)	Ht (cm)	Az (deg)	Limit (dBuV/m)	Margin (dB)	Pass /Fail	Comments
5582.63	34.33	21.07	-3.42	51.98	Preview	H	200	352	54	-2.02	Pass	
3932.18	36.15	19.72	-4.71	51.16	Preview	V	100	0	54	-2.84	Pass	
1647.35	32.34	18.47	-9.94	40.87	Debug	H	101	352	54	-13.13	Pass	

Note: Preview data was measured using a peak detector to identify frequencies of interest for formal measurement. Formal data consist of all frequencies in the preview list within 6 dB of specification limit or the top six frequencies. Failure in preview data does not necessarily constitute failure in formal data.

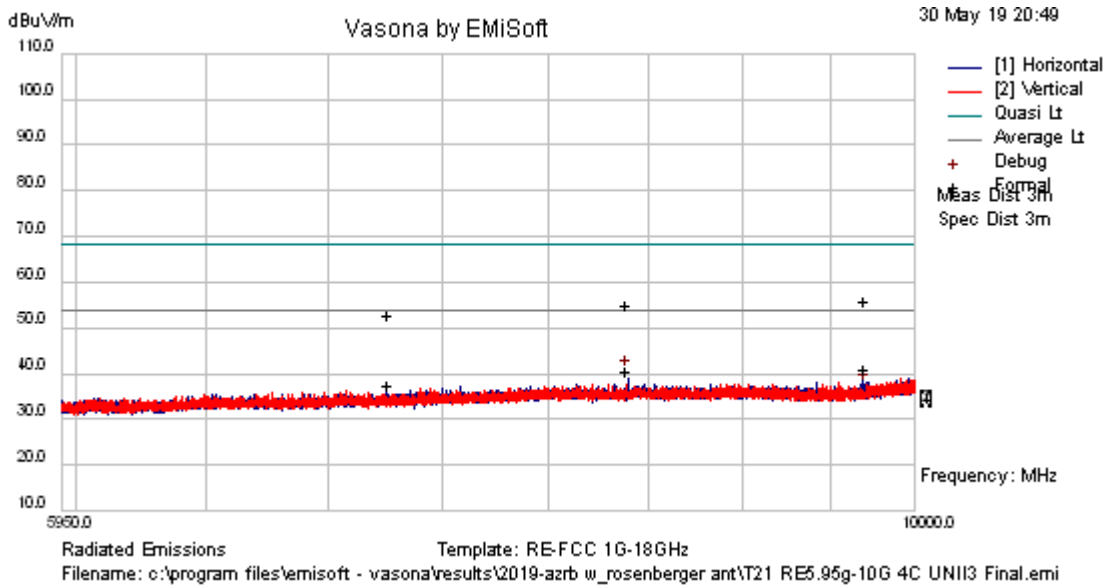

Results Title:	RE-FCC 1G-18GHz
File Name:	c:\program files\emisoft - vasona\results\2019-azrb w_rosenberger ant\T21 RE5.95g-10G 4C UNII3 Final.emi
Test Laboratory:	AR4-MH, 24C, 44% 977mB
Test Engineer:	MJS
Test Software:	Vasona by EMISoft, version 2.161
Equipment:	Nokia
EUT Details:	2019-0082 AZRB PN: 474510A.101, S/N: 1M181319958 with Rosenberger Base Station Antenna PN: BA-AIO3O3T3T3VJX65F-06, SN: RAPAFO1183927707, Power Supply Module PN: 474130A.102, S/N: U7182703949, Modulation ETM3.2, 26dBm, 4C-UNII-3 - Transmitting @ 5765M, 5785M, 5805M, 5825MHz, 80MHz BW L, Powered by 120VAC. Tx Back on, full scan with formals.
Configuration:	Radiated Emissions 5.95GHz - 10GHz, FCC Class B Limit, Ant E1073, RCVR ESU-1G IH69, Pre-Amp E447, E1212-HPF, Ref Lvl 110dB, Int attn 10dB, Preview RBW 30kHz Formal RBW 1MHz, 3m measurement distance, straight bore, no tilt.
Date:	2019-05-30 20:49:30

FORMAL DATA												
Freq. (MHz)	Raw (dBuV)	Cable (dB)	Factor (dB)	Level (dBuV/m)	Emission Type	Pol (H/V)	Ht (cm)	Az (deg)	Limit (dBuV/m)	Margin (dB)	Pass /Fail	Comments
9708.4	46.01	7.84	-2.15	51.7	Peak	H	379	277	68.2	-16.5	Pass	
9708.4	30.9	7.84	-2.15	36.59	Average	H	379	277	54	-17.41	Pass	NA
8399.23	44.88	8.66	-2.78	50.77	Peak	H	368	178	68.2	-17.43	Pass	
8399.23	30.19	8.66	-2.78	36.08	Average	H	368	178	54	-17.92	Pass	
7266.54	44.23	7.19	-2.66	48.77	Peak	V	307	106	68.2	-19.43	Pass	
7266.54	28.71	7.19	-2.66	33.24	Average	V	307	106	54	-20.76	Pass	

PREVIEW DATA												
Freq. (MHz)	Raw (dBuV)	Cable (dB)	Factor (dB)	Level (dBuV/m)	Emission Type	Pol (H/V)	Ht (cm)	Az (deg)	Limit (dBuV/m)	Margin (dB)	Pass /Fail	Comments
8399.23	33.11	8.66	-2.78	38.99	Preview	H	300	264	54	-15.01	Pass	
9708.4	30.31	7.84	-2.15	36	Debug	H	101	352	54	-18	Pass	
7266.54	28.82	7.19	-2.66	33.35	Debug	V	101	352	54	-20.65	Pass	

Note: Preview data was measured using a peak detector to identify frequencies of interest for formal measurement. Formal data consist of all frequencies in the preview list within 6 dB of specification limit or the top six frequencies. Failure in preview data does not necessarily constitute failure in formal data.

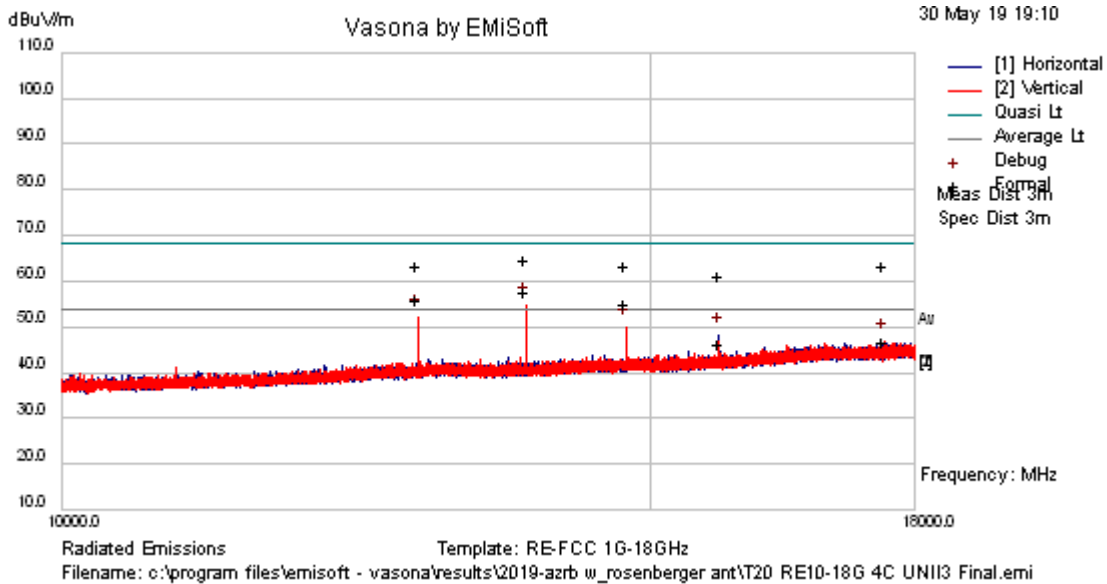

Results Title:	RE-FCC 1G-18GHz
File Name:	c:\program files\emisoft - vasona\results\2019-azrb w_rosenberger ant\T20 RE10-18G 4C UNII3 Final.emi
Test Laboratory:	AR4-MH, 24C, 44% 977mB
Test Engineer:	MJS
Test Software:	Vasona by EMISoft, version 2.161
Equipment:	Nokia

EUT Details:	2019-0082 AZRB PN: 474510A.101, S/N: 1M181319958 with Rosenberger Base Station Antenna PN: BA-AIO3O3T3T3VJX65F-06, SN: RAPAFO1183927707, Power Supply Module PN: 474130A.102, S/N: U7182703949, Modulation ETM3.2, 26dBm, 4C-UNII-3 - Transmitting @ 5765M, 5785M, 5805M, 5825MHz, 80MHz BW L, Powered by 120VAC. Tx Back on, full scan with formals.
Configuration:	Radiated Emissions 10GHz - 18GHz, FCC Class B Limit, Ant E1073, RCVR ESU-1G IH69, Pre-Amp E447, E1212-HPF, Ref Lvl 110dB, Int attn 10dB, Preview RBW 30kHz Formal RBW 1MHz, 3m measurement distance, straight bore, no tilt.
Date:	2019-05-30 19:10:54

FORMAL DATA												
Freq. (MHz)	Raw (dBuV)	Cable (dB)	Factor (dB)	Level (dBuV/m)	Emission Type	Pol (H/V)	Ht (cm)	Az (deg)	Limit (dBuV/m)	Margin (dB)	Pass /Fail	Comments
13762.6	41.79	9.57	2.1	53.45	Average	V	100	310	54	-0.55	Pass	
12779.5	40.84	9.25	1.7	51.79	Average	V	110	248	54	-2.21	Pass	
14745.6	38.67	9.78	2.29	50.73	Average	V	132	328	54	-3.27	Pass	
13762.6	48.73	9.57	2.1	60.4	Peak	V	100	310	68.2	-7.8	Pass	
14745.6	47.09	9.78	2.29	59.15	Peak	V	132	328	68.2	-9.05	Pass	
12779.5	48.19	9.25	1.7	59.14	Peak	V	110	248	68.2	-9.06	Pass	
17611.6	44.41	10.22	4.5	59.12	Peak	V	201	183	68.2	-9.08	Pass	
15728.6	44.65	9.89	2.4	56.93	Peak	H	264	239	68.2	-11.27	Pass	
17611.6	27.91	10.22	4.5	42.62	Average	V	201	183	54	-11.38	Pass	
15728.6	29.61	9.89	2.4	41.9	Average	H	264	239	54	-12.1	Pass	

PREVIEW DATA

Freq. (MHz)	Raw (dBuV)	Cable (dB)	Factor (dB)	Level (dBuV/m)	Emission Type	Pol (H/V)	Ht (cm)	Az (deg)	Limit (dBuV/m)	Margin (dB)	Pass /Fail	Comments
13762.9	42.9	9.57	2.1	54.57	Preview	V	100	308	54	0.57	Fail	
12779.5	41.31	9.25	1.7	52.26	Preview	V	100	220	54	-1.74	Pass	
14745.6	37.76	9.78	2.29	49.82	Preview	V	100	352	54	-4.18	Pass	
15729	35.8	9.89	2.4	48.09	Preview	H	100	0	54	-5.91	Pass	
17611.6	32.21	10.22	4.5	46.93	Preview	V	200	220	54	-7.07	Pass	

Note: Preview data was measured using a peak detector to identify frequencies of interest for formal measurement. Formal data consist of all frequencies in the preview list within 6 dB of specification limit or the top six frequencies. Failure in preview data does not necessarily constitute failure in formal data.

5.2.2 Radiated Spurious Emissions – Plots PAS2457-CC1 Antenna #9

Spurious_TM3.2_1C_20MBW_5180_29dBm at AZRB, 30-26GHz_PAS2457-CC1

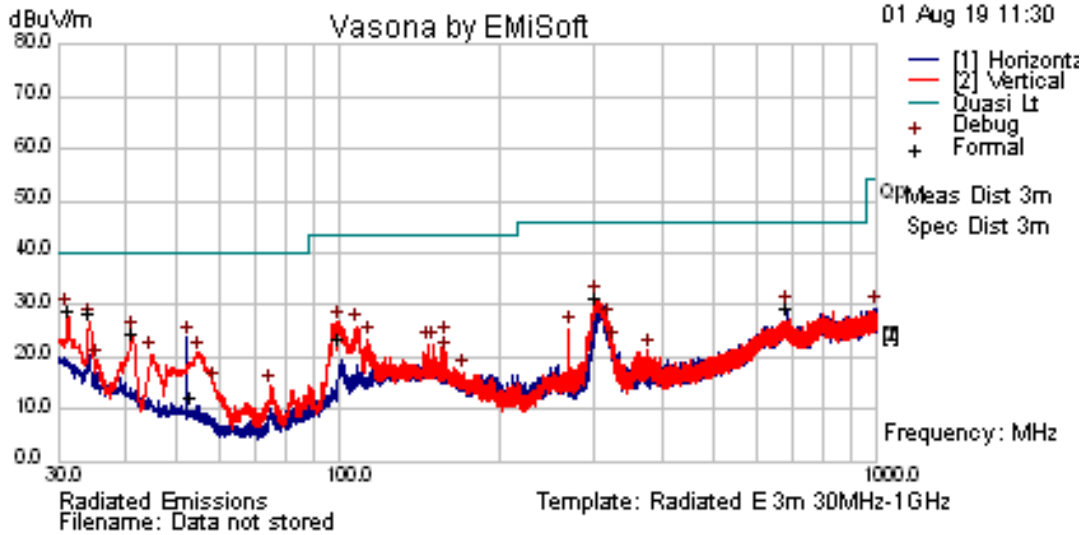

Results Title:	Radiated E 3m 30MHz-1GHz
File Name:	c:\program files\emisoft - vasona\results\2019-0119 laird ant.\re-tT5 - 30- 1GHz unii-1-1c.emi
Test Laboratory:	GPCL AR5-MH 24C, 16%RH, 1008mB
Test Engineer:	EEM/CP
Test Software:	Vasona by EMISoft, version 2.161
Equipment:	Nokia Networks
EUT Details:	AZRB with Laird Directional Panel Antenna. AZRB P/N 2205 B46 LAA-20170916, S/N X61W800212, PSU PN-474130A.102, SNU7182703949, W470003170-00010, Laird Directional Panel Antenna [Ant. PAS24527-CC1, S/N 1850010] Laird Directional Panel Antenna [Ant. PAS24527-CC1, S/N 1850010] Laird Directional Panel Antenna [Ant. PAS24527-CC1, S/N 1850010] UNII-1 (High), 1 Carrier, 5180M [ETM3.2], 26dBm. Carrier BW= 20 MHz
Configuration :	Powered by 120VAC / 60Hz, Horn Antenna E530, ESU E954 with 90dBuV Reference Level & Internal Attenuation 10dB, Sonoma 310N Preamp-E507; Bi-Log Ant. SAS-521 [E602]. Preview BW (100 kHz RBW/ 300 KHz VBW); Formal BW (120kHz RBW). FCC Part 15 Class B. RE Spurious Emissions. Project 2019-0119 [Freq. Range: 30 Mhz -1 GHz]
Date:	2019-08-01 11:42:12

FORMAL DATA

Freq. (MHz)	Raw (dBuV)	Cable (dB)	Factor (dB)	Level (dBuV/m)	Emission Type	Pol (H/V)	Ht (cm)	Az (deg)	Limit (dBuV/m)	Margin (dB)	Pass /Fail	Comments
31.189	35.8	0.61	-9.89	26.53	Quasi Max	V	127	133	40	-13.47	Pass	
34.321	36.69	0.62	-11.5	25.81	Quasi Max	V	100	324	40	-14.19	Pass	
301.654	38.55	1.51	-11.1	28.99	Quasi Max	V	125	198	46	-17.01	Pass	
41.308	36.61	0.63	-15.2	22.07	Quasi Max	V	113	251	40	-17.93	Pass	
681.006	28.44	2.2	-3.39	27.25	Quasi Max	H	144	273	46	-18.75	Pass	
99.6923	34.31	0.88	-14.2	20.96	Quasi Max	V	199	283	43.5	-22.54	Pass	
52.949	28.9	0.65	-19.8	9.76	Quasi Max	H	215	360	40	-30.24	Pass	

**PREVIEW
DATA**

Freq. (MHz)	Raw (dBuV)	Cable (dB)	Factor (dB)	Level (dBuV/m)	Emission Type	Pol (H/V)	Ht (cm)	Az (deg)	Limit (dBuV/m)	Margin (dB)	Pass /Fail	Comments
31.1538	38.34	0.61	-9.87	29.08	Preview	V	102	0	40	-10.92	Pass	
34.2308	37.66	0.62	-11.5	26.83	Preview	V	102	0	40	-13.17	Pass	
300.692	40.74	1.51	-11	31.24	Preview	V	102	0	46	-14.76	Pass	
41.3846	39.03	0.63	-15.2	24.45	Preview	V	102	315	40	-15.55	Pass	
52.1538	42.55	0.65	-19.6	23.65	Preview	H	290	180	40	-16.35	Pass	
681.538	30.5	2.2	-3.41	29.29	Preview	H	390	135	46	-16.71	Pass	
99.6923	40.08	0.88	-14.2	26.73	Preview	V	202	225	43.5	-16.77	Pass	
107.923	37.84	0.92	-12.8	25.99	Preview	V	102	180	43.5	-17.51	Pass	
318.923	37.56	1.54	-12.1	26.98	Preview	V	102	180	46	-19.02	Pass	
55	40.52	0.66	-20.4	20.79	Preview	V	102	225	40	-19.21	Pass	
44.6154	36.7	0.63	-16.7	20.61	Preview	V	102	270	40	-19.39	Pass	
157.077	32.81	1.14	-10.4	23.6	Preview	V	102	45	43.5	-19.9	Pass	
113.231	34.35	0.95	-11.9	23.39	Preview	V	102	0	43.5	-20.11	Pass	
268.615	37.17	1.45	-13.2	25.43	Preview	V	390	180	46	-20.57	Pass	
35.3846	30.7	0.62	-12	19.28	Preview	V	102	270	40	-20.72	Pass	
149.769	30.6	1.11	-9.23	22.49	Preview	V	102	45	43.5	-21.01	Pass	
146.769	30.67	1.1	-9.33	22.44	Preview	V	102	45	43.5	-21.06	Pass	
157.615	29.98	1.14	-10.4	20.69	Preview	V	102	45	43.5	-22.81	Pass	
324.538	33.44	1.55	-12.5	22.54	Preview	V	202	0	46	-23.46	Pass	
998.686	28.33	2.82	-1.77	29.38	Preview	H	102	225	54	-24.62	Pass	
377	31.04	1.63	-11.5	21.13	Preview	V	202	0	46	-24.87	Pass	
58.6923	35.38	0.68	-21.1	14.93	Preview	V	102	180	40	-25.07	Pass	
74.6923	33.79	0.75	-20.2	14.31	Preview	V	102	180	40	-25.69	Pass	
171.231	28.47	1.19	-12.5	17.18	Preview	V	102	90	43.5	-26.32	Pass	

Note: Preview data was measured using a peak detector to identify frequencies of interest for formal measurement. Formal data consist of all frequencies in the preview list within 6 dB of specification limit or the top six frequencies. Failure in preview data does not necessarily constitute failure in formal data.

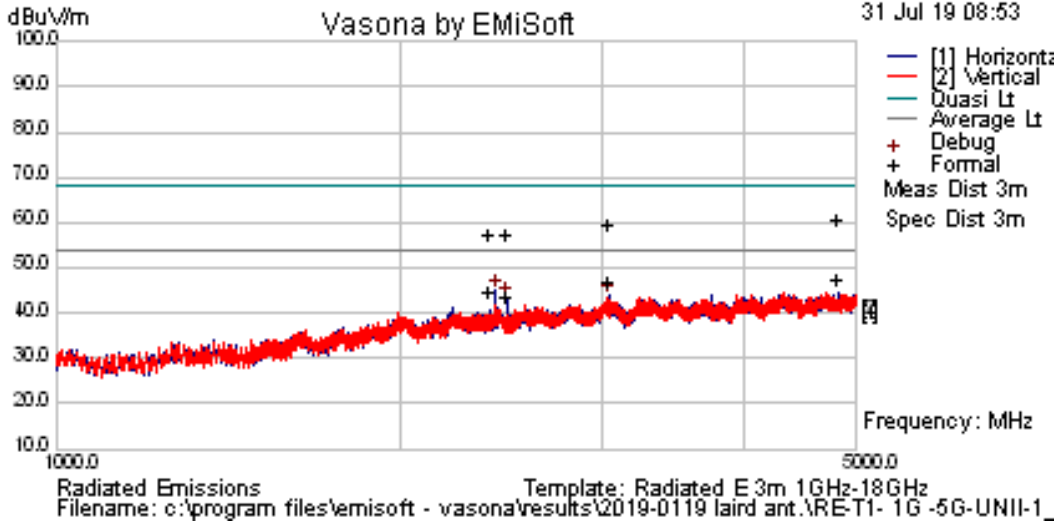

Results Title:	Radiated E 3m 1GHz-18GHz
File Name:	c:\program files\emisoft - vasona\results\2019-0119 laird ant.\RE-T1- 1G -5G-UNII-1_1 Carrier.emi
Test Laboratory:	GPCL AR5-MH 24C, 16%RH, 1008mB
Test Engineer:	EEM
Test Software:	Vasona by EMISoft, version 2.161
Equipment:	Nokia Networks
EUT Details:	AZRB with Laird Directional Panel Antenna. AZRB P/N 2205 B46 LAA-20170916, S/N X61W800212, PSU PN-474130A.102, SNU7182703949, W470003170-00010, Laird Directional Panel Antenna [Ant. PAS24527-CC1, S/N 1850010] Laird Directional Panel Antenna [Ant. PAS24527-CC1, S/N 1850010] Laird Directional Panel Antenna [Ant. PAS24527-CC1, S/N 1850010] UNII-1 (High) , 1 Carrier, 5180M [ETM3.2], 26dBm. Carrier BW= 20 MHz
Configuration :	Powered by 120VAC / 60Hz, Horn Antenna E1074, ESU-1G- E954 with 90dBuV Reference Level & Internal Attenuation 0dB, HP Preamp-E447 [Atten. E178+177] 10 dB & 6 dB Pad. Preview BW (30 kHz RBW/ 3000 KHz VBW); Formal BW (1MHz RBW). FCC Part 15 Class B. RE Spurious Emissions. Project 2019-0119 [Freq. Range: 1 GHz - 5.0GHz)
Date:	2019-07-31 08:53:07

FORMAL DATA

Freq. (MHz)	Raw (dBuV)	Cable (dB)	Factor (dB)	Level (dBuV/m)	Emission Type	Pol (H/V)	Ht (cm)	Az (deg)	Limit (dBuV/m)	Margin (dB)	Pass /Fail	Comments
4829.21	28.22	20.57	-3.91	44.88	AvgMax	H	394	38	54	-9.12	Pass	
3043.41	31.04	19.41	-6.11	44.35	AvgMax	H	227	297	54	-9.65	Pass	NA
4829.21	41.44	20.57	-3.91	58.1	Peak	H	394	38	68.2	-10.1	Pass	
3043.41	43.9	19.41	-6.11	57.2	Peak	H	227	297	68.2	-11	Pass	
2397.52	29.15	19.05	-6.39	41.81	AvgMax	H	122	210	54	-12.19	Pass	NA
2477.63	28.25	19.1	-6.19	41.17	AvgMax	H	180	140	54	-12.83	Pass	NA
2397.52	42.27	19.05	-6.39	54.94	Peak	H	122	210	68.2	-13.26	Pass	
2477.63	41.67	19.1	-6.19	54.58	Peak	H	180	140	68.2	-13.62	Pass	

PREVIEW DATA

Freq. (MHz)	Raw (dBuV)	Cable (dB)	Factor (dB)	Level (dBuV/m)	Emission Type	Pol (H/V)	Ht (cm)	Az (deg)	Limit (dBuV/m)	Margin (dB)	Pass /Fail	Comments
2425.6	32.25	19.07	-6.32	45	Preview	H	290	180	54	-9	Pass	
4829.21	28.03	20.57	-3.91	44.69	Preview	H	390	315	54	-9.31	Pass	
3045.84	30.51	19.42	-6.1	43.82	Preview	H	102	90	54	-10.18	Pass	
2479.59	30.49	19.1	-6.18	43.41	Preview	H	190	270	54	-10.59	Pass	

Note: Preview data was measured using a peak detector to identify frequencies of interest for formal measurement. Formal data consist of all frequencies in the preview list within 6 dB of specification limit or the top six frequencies. Failure in preview data does not necessarily constitute failure in formal data.

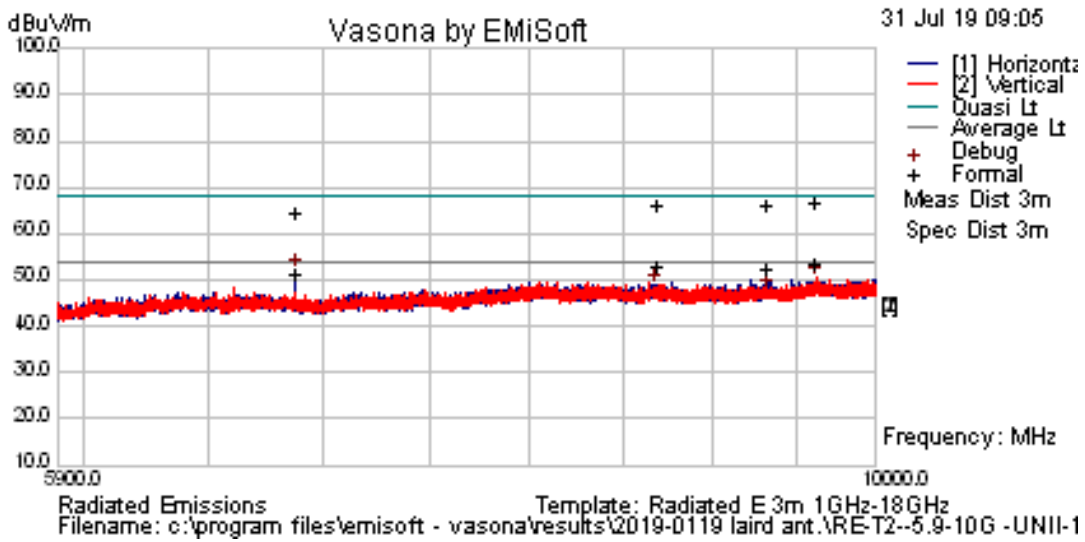

Results Title:	Radiated E 3m 1GHz-18GHz
File Name:	c:\program files\emisoft - vasona\results\2019-0119 laird ant.\RE-T2--5.9-10G -UNII-1_1.emi
Test Laboratory:	GPCL AR5-MH 24C, 16%RH, 1008mB
Test Engineer:	EEM
Test Software:	Vasona by EMISoft, version 2.161
Equipment:	Nokia Networks
EUT Details:	AZRB with Laird Directional Panel Antenna. AZRB P/N 2205 B46 LAA-20170916, S/N X61W800212, PSU PN-474130A.102, SNU7182703949, W470003170-00010, Laird Directional Panel Antenna [Ant. PAS24527-CC1, S/N 1850010] Laird Directional Panel Antenna [Ant. PAS24527-CC1, S/N 1850010] Laird Directional Panel Antenna [Ant. PAS24527-CC1, S/N 1850010] UNII-1 (High), 1 Carrier, 5180M [ETM3.2], 26dBm. Carrier BW= 20 MHz
Configuration :	Powered by 120VAC / 60Hz, Horn Antenna E1074, ESU-1G- E954 with 90dBuV Reference Level & Internal Attenuation 0dB, HP Preamp-E447 [Atten. E178+177] 10 dB & 6 dB Pad. Preview BW (30 kHz RBW/ 3000 KHz VBW); Formal BW (1MHz RBW). . FCC Part 15 Class B. RE Spurious Emissions. Project 2019-0119 [Freq. Range: 5.9GHz - 10GHz)
Date:	2019-07-31 09:05:54

FORMAL DATA

Freq. (MHz)	Raw (dBuV)	Cable (dB)	Factor (dB)	Level (dBuV/m)	Emission Type	Pol (H/V)	Ht (cm)	Az (deg)	Limit (dBuV/m)	Margin (dB)	Pass /Fail	Comments
9628.79	30.13	22.85	-2.24	50.73	AvgMax	V	380	65	54	-3.27	Pass	NA
8697.08	29.79	22.98	-2.65	50.12	AvgMax	H	249	44	54	-3.88	Pass	NA
9339.54	29.47	22.95	-2.45	49.97	AvgMax	H	232	172	54	-4.03	Pass	
9628.79	43.52	22.85	-2.24	64.12	Peak	V	380	65	68.2	-4.08	Pass	
9339.54	43.23	22.95	-2.45	63.73	Peak	H	232	172	68.2	-4.47	Pass	
8697.08	43.36	22.98	-2.65	63.7	Peak	H	249	44	68.2	-4.5	Pass	
6881.27	29.93	21.29	-2.57	48.65	AvgMax	H	203	342	54	-5.35	Pass	NA
6881.27	43.01	21.29	-2.57	61.73	Peak	H	203	342	68.2	-6.47	Pass	

PREVIEW DATA

Freq. (MHz)	Raw (dBuV)	Cable (dB)	Factor (dB)	Level (dBuV/m)	Emission Type	Pol (H/V)	Ht (cm)	Az (deg)	Limit (dBuV/m)	Margin (dB)	Pass /Fail	Comments
6881.72	33.41	21.29	-2.57	52.14	Preview	H	102	315	54	-1.86	Pass	
9628.79	29.8	22.85	-2.24	50.41	Preview	V	302	315	54	-3.59	Pass	
9339.54	27.22	22.95	-2.45	47.72	Debug	H	100	325	54	-6.28	Pass	
8681.37	28.54	22.98	-2.65	48.87	Debug	H	100	325	54	-5.13	Pass	

Note: Preview data was measured using a peak detector to identify frequencies of interest for formal measurement. Formal data consist of all frequencies in the preview list within 6 dB of specification limit or the top six frequencies. Failure in preview data does not necessarily constitute failure in formal data.

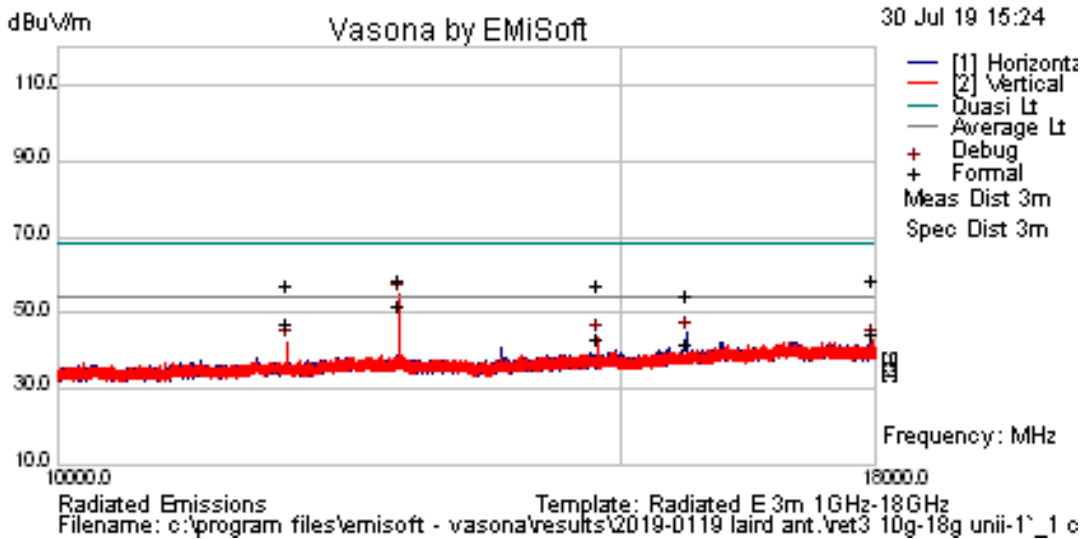

Results Title:	Radiated E 3m 1GHz-18GHz
File Name:	c:\program files\emisoft - vasona\results\2019-0119 laird ant.\ret3 10G-18G unii-1`_1 Carrier.emi
Test Laboratory:	GPCL AR5-MH 24C, 16%RH, 1008mB
Test Engineer:	EEM
Test Software:	Vasona by EMISoft, version 2.161

Equipment:	Nokia Networks
EUT Details:	AZRB with Laird Directional Panel Antenna. AZRB P/N 2205 B46 LAA-20170916, S/N X61W800212, PSU PN-474130A.102, SNU7182703949, W470003170-00010, Laird Directional Panel Antenna [Ant. PAS24527-CC1, S/N 1850010] Laird Directional Panel Antenna [Ant. PAS24527-CC1, S/N 1850010] Laird Directional Panel Antenna [Ant. PAS24527-CC1, S/N 1850010] UNII-1 (High), 1 Carrier, 5180M [ETM3.2], 26dBm. Carrier BW= 20 MHz
Configuration :	Powered by 120VAC / 60Hz, Horn Antenna E1074, ESU-1G- E954 with 90dBuV Reference Level & Internal Attenuation 0dB, HP Preamp-E447, E1212 5GHz High Pass Filter. Preview BW (30 kHz RBW/ 3000 KHz VBW); Formal BW (1MHz RBW). FCC Part 15 Class B . RE Spurious Emissions. Project 2019-0119 [Freq. Range: 10GHz - 18GHz)
Date:	2019-07-30 15:24:41

FORMAL DATA

Freq. (MHz)	Raw (dBuV)	Cable (dB)	Factor (dB)	Level (dBuV/m)	Emission Type	Pol (H/V)	Ht (cm)	Az (deg)	Limit (dBuV/m)	Margin (dB)	Pass /Fail	Comments
12779.5	37.55	8.95	1.77	48.27	AvgMax	V	100	285	54	-5.73	Pass	*
11796.8	35.43	8.71	-0.05	44.09	AvgMax	V	168	0	54	-9.91	Pass	
17965.5	26.46	10.66	4.15	41.27	AvgMax	V	304	259	54	-12.73	Pass	
12779.5	44.74	8.95	1.77	55.46	Peak	V	100	285	68.2	-12.74	Pass	
17965.5	40.62	10.66	4.15	55.43	Peak	V	304	259	68.2	-12.77	Pass	
14745.6	42.49	9.53	2.19	54.2	Peak	V	211	0	68.2	-14	Pass	
14745.6	28.21	9.53	2.19	39.93	AvgMax	V	211	0	54	-14.07	Pass	NA
11796.8	45.2	8.71	-0.05	53.86	Peak	V	168	0	68.2	-14.34	Pass	
15729	26.42	9.89	2.11	38.42	AvgMax	H	329	358	54	-15.58	Pass	
15729	39.44	9.89	2.11	51.44	Peak	H	329	358	68.2	-16.76	Pass	

*not related to carrier ON/OFF

PREVIEW DATA

Freq. (MHz)	Raw (dBuV)	Cable (dB)	Factor (dB)	Level (dBuV/m)	Emission Type	Pol (H/V)	Ht (cm)	Az (deg)	Limit (dBuV/m)	Margin (dB)	Pass /Fail	Comments
12779.5	44.1	8.95	1.77	54.82	Preview	V	102	270	54	0.82	Fail	
15729	32.79	9.89	2.11	44.79	Preview	H	102	45	54	-9.21	Pass	
14745.6	32.03	9.53	2.19	43.74	Preview	V	102	0	54	-10.26	Pass	
17965.5	27.81	10.66	4.15	42.62	Preview	V	102	270	54	-11.38	Pass	
11796.8	33.53	8.71	-0.05	42.19	Preview	V	202	0	54	-11.81	Pass	

Note: Preview data was measured using a peak detector to identify frequencies of interest for formal measurement. Formal data consist of all frequencies in the preview list within 6 dB of specification limit or the top six frequencies. Failure in preview data does not necessarily constitute failure in formal data.

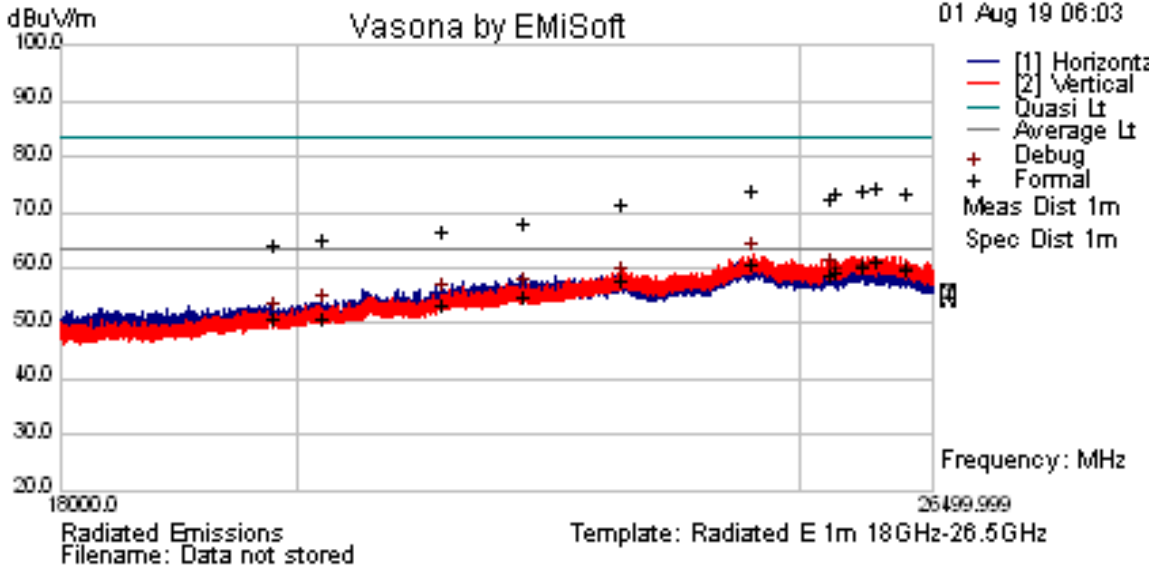

Results Title:	Radiated E 1m 18GHz-26.5GHz
File Name:	c:\program files\emisoft - vasona\results\2019-0119 laird ant.\RE-T4 - 18G-26.5G-UNII-1-1C.emi
Test Laboratory:	GPCL AR5-MH 24C, 16%RH, 1008mB
Test Engineer:	EEM/CP
Test Software:	Vasona by EMISoft, version 2.161
Equipment:	Nokia Networks
EUT Details:	AZRB with Laird Directional Panel Antenna. AZRB P/N 2205 B46 LAA-20170916, S/N X61W800212, PSU PN-474130A.102, SNU7182703949, W470003170-00010, Laird Directional Panel Antenna [Ant PAS24527-CC1, S/N 1850010] Laird Directional Panel Antenna [Ant. PAS24527-CC1, S/N 1850010] Laird Directional Panel Antenna [Ant. PAS24527-CC1, S/N 1850010] UNII-1 (High), 1 Carrier, 5180M [ETM3.2], 26dBm. Carrier BW= 20 MHz
Configuration :	Powered by 120VAC / 60Hz, Horn Antenna E530, ESU-1G- E954 with 90dBuV Reference Level & Internal Attenuation 0dB, HP Preamp-E447 Preview BW (100 kHz RBW/ 3000 KHz VBW); Formal BW (1MHz RBW). FCC Part 15 Class B. RE Spurious Emissions. Project 2019-0119 [Freq. Range: 18GHz-26.5GHz]
Date:	2019-08-01 06:05:56

FORMAL DATA

Freq. (MHz)	Raw (dBuV)	Cable (dB)	Factor (dB)	Level (dBuV/m)	Emission Type	Pol (H/V)	Ht (cm)	Az (deg)	Limit (dBuV/m)	Margin (dB)	Pass /Fail	Comments
25865.2	30.06	17.62	11.01	58.69	AvgMax	V	173	175	63.5	-4.81	Pass	NA
24474.3	30.76	17.87	9.67	58.3	AvgMax	V	188	188	63.5	-5.2	Pass	NA
25709.8	29.44	17.61	10.87	57.91	AvgMax	V	160	191	63.5	-5.59	Pass	NA
26202.2	28.67	16.9	11.72	57.3	AvgMax	V	174	182	63.5	-6.2	Pass	NA
25397.7	28.9	17.58	10.56	57.05	AvgMax	V	150	122	63.5	-6.45	Pass	NA
25346.2	28.37	17.58	10.51	56.47	AvgMax	V	138	237	63.5	-7.03	Pass	NA
23109.1	27.99	17.93	9.44	55.36	AvgMax	V	182	221	63.5	-8.14	Pass	
22112.3	26.58	16.81	9.24	52.62	AvgMax	V	119	56	63.5	-10.88	Pass	
25865.2	43.52	17.62	11.01	72.16	Peak	V	173	175	77.7	-5.54	Pass	

**FORMAL
DATA**

Freq. (MHz)	Raw (dBuV)	Cable (dB)	Factor (dB)	Level (dBuV/m)	Emission Type	Pol (H/V)	Ht (cm)	Az (deg)	Limit (dBuV/m)	Margin (dB)	Pass /Fail	Comments
25709.8	43.26	17.61	10.87	71.73	Peak	V	160	191	77.7	-5.97	Pass	
24474.3	44.03	17.87	9.67	71.57	Peak	V	188	188	77.7	-6.13	Pass	
25397.7	42.86	17.58	10.56	71.01	Peak	V	150	122	77.7	-6.69	Pass	
26202.2	42.33	16.9	11.72	70.96	Peak	V	174	182	77.7	-6.74	Pass	
21322.8	26.18	15.37	9.41	50.96	AvgMax	V	115	114	63.5	-12.54	Pass	
25346.2	42.06	17.58	10.51	70.15	Peak	V	138	237	77.7	-7.55	Pass	
23109.1	41.6	17.93	9.44	68.97	Peak	V	182	221	77.7	-8.73	Pass	
19796.8	26.86	13.25	8.38	48.49	AvgMax	V	104	81	63.5	-15.01	Pass	NA
20238	26.09	13.74	8.61	48.44	AvgMax	V	107	314	63.5	-15.06	Pass	NA
22112.3	39.56	16.81	9.24	65.61	Peak	V	119	56	77.7	-12.09	Pass	
21322.8	39.57	15.37	9.41	64.35	Peak	V	115	114	77.7	-13.35	Pass	
20237.3	40.55	13.74	8.61	62.9	Peak	V	104	317	77.7	-14.8	Pass	
19796.8	40.26	13.25	8.38	61.89	Peak	V	104	81	77.7	-15.81	Pass	

**PREVIEW
DATA**

Freq. (MHz)	Raw (dBuV)	Cable (dB)	Factor (dB)	Level (dBuV/m)	Emission Type	Pol (H/V)	Ht (cm)	Az (deg)	Limit (dBuV/m)	Margin (dB)	Pass /Fail	Comments
24474.3	34.67	17.87	9.67	62.2	Preview	V	200	176	63.5	-1.3	Pass	
26202.2	29.35	16.9	11.72	57.98	Debug	V	101	355	63.5	-5.52	Pass	
25865.2	30.31	17.62	11.01	58.94	Debug	V	101	355	63.5	-4.56	Pass	
25709.8	30.03	17.61	10.87	58.5	Debug	V	101	355	63.5	-5	Pass	
23109.1	30.3	17.93	9.44	57.67	Debug	V	101	355	63.5	-5.83	Pass	
22112.3	29.86	16.81	9.24	55.91	Debug	V	101	355	63.5	-7.59	Pass	
19796.8	29.82	13.25	8.38	51.45	Debug	V	101	355	63.5	-12.05	Pass	
21322.8	30.29	15.37	9.41	55.07	Debug	V	101	355	63.5	-8.43	Pass	
25397.7	29.66	17.58	10.56	57.81	Debug	V	101	355	63.5	-5.69	Pass	
25346.2	31.22	17.58	10.51	59.31	Debug	V	101	355	63.5	-4.19	Pass	
20238	30.48	13.74	8.61	52.82	Debug	V	101	355	63.5	-10.68	Pass	

Note: Preview data was measured using a peak detector to identify frequencies of interest for formal measurement. Formal data consist of all frequencies in the preview list within 6 dB of specification limit or the top six frequencies. Failure in preview data does not necessarily constitute failure in formal data.

Photographs





Test Equipment

Asset ID	Manufacturer	Type	Description	Model	Serial	Calibration Date	Calibration Due	Calibration Type
E1073	ETS Lindgren	Horn Antenna	Double-Ridged Waveguide Horn 1-18 GHz	3117	00135198	2017-06-09	2019-08-09	Requires Calibration
E1321	Extech	Data Logger	Barometric Pressure/Humidity/Temperature Datalogger	SD700	A075782	2018-11-07	2020-11-07	Requires Calibration
E1365	GPCL	Notch Filter	LAA Notch Filter	1P	Q4971A01			Calibration Not Required, must be Verified
E1356	Hewlett Packard	Pre-Amplifier	Pre-Amplifier 1-26.5GHz	8449B	3008A01353	2018-09-10	2020-09-10	Requires Calibration
EH69	Rohde & Schwarz	Test Receiver	EMI 20Hz - 40GHz -155 dBm +30 dBm	ESU40	100247	2018-05-22	2020-05-22	Requires Calibration
E588	Sunol Sciences	System Controller		SC99V	32802-1			Calibration Not Required
E1328	A-Info	Horn Antenna	26.5-40GHz WR28 dB	LB-28-25-C2-KF	J202023250	2018-10-16	2021-10-16	Requires Calibration
E766	A.H. Systems Inc.	Biological Antenna	25 - 2000 MHz	SAS-521-2	457	2019-02-13	2021-02-13	Requires Calibration
E447	Hewlett Packard	Pre-Amplifier	Preamplifier 1-26.5 GHz	8449B	3008A01384	2018-04-10	2020-04-10	Requires Calibration

Asset ID	Manufacturer	Type	Description	Model	Serial	Calibration Date	Calibration Due	Calibration Type
E1212	RLC Electronics Inc	High Pass Filter	High Pass Filter 10-30 GHz	F-19414	1444002			Calibration Not Required, Must Be Verified
E954	Rohde & Schwarz	Test Receiver	EMI 20Hz - 40GHz -155 dBm +30 dBm	ESU40	100246	2018-09-11	2020-09-11	Requires Calibration
E813	Sonoma Instrument	Amplifier	9kHz-1GHz	310N	186750	2018-09-14	2020-09-14	Requires Calibration
E177	Weinschel	Attenuator	10 dB, 18GHz 2 watt	2-10	BC0304	2018-06-26	2020-06-26	Requires Calibration
E176	Weinschel	Attenuator	6 dB, 2 Watt DC-12.5 GHz	2-6	BC0255	2018-06-29	2020-06-29	Requires Calibration
E520	EMC Test Systems	Horn Antenna	Double Ridged Horn 18-40 GHz	3116	2537	2018-08-09	2020-08-09	Requires Calibration

6. NVLAP Certificate of Accreditation

United States Department of Commerce
National Institute of Standards and Technology

NVLAP[®]

Certificate of Accreditation to ISO/IEC 17025:2005

NVLAP LAB CODE: 100275-0

Nokia, Global Product Compliance Lab
Murray Hill, NJ

*is accredited by the National Voluntary Laboratory Accreditation Program for specific services,
listed on the Scope of Accreditation, for:*

Electromagnetic Compatibility & Telecommunications

*This laboratory is accredited in accordance with the recognized International Standard ISO/IEC 17025:2005.
This accreditation demonstrates technical competence for a defined scope and the operation of a laboratory quality
management system (refer to joint ISO-ILAC-IAF Communiqué dated January 2009).*

2018-09-05 through 2019-09-30

Effective Dates





For the National Voluntary Laboratory Accreditation Program