

Global Product Compliance Laboratory
600-700 Mountain Avenue
Room 5B-108
Murray Hill, New Jersey 07974-0636 USA

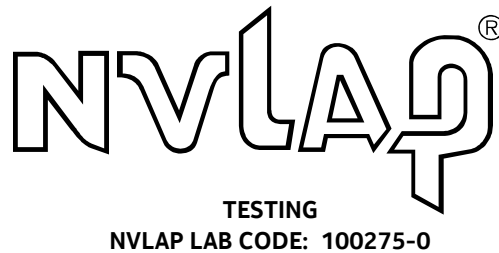

Title 47 Code of Federal Regulations Test Report

Regulation:

Title 47 CFR FCC Part 25

Client:

NOKIA SOLUTIONS AND NETWORKS, OY

Product Evaluated:

AirScale Micro RRH AWHKB 4T4R B24 8W

Report Number:

TR-2022-0083-FCC25

Date Issued:

September 15, 2022

This report shall not be reproduced, in whole or in part without the approval of Nokia Global Product Compliance Laboratory. This report must not be used by the recipient to claim product certification, approval, or endorsement by NVLAP, NIST, or any agency of the U.S. Government.

Table of Contents

- 1. SYSTEM INFORMATION AND REQUIREMENTS 4**
 - 1.1 INTRODUCTION 5
 - 1.2 PURPOSE AND SCOPE 5
 - 1.3 EUT DETAILS 5
 - 1.4 TEST REQUIREMENTS..... 7
 - 1.5 TEST STANDARDS & MEASUREMENT PROCEDURES 7
 - 1.6 MEASUREMENT UNCERTAINTY 8
 - 1.7 EXECUTIVE SUMMARY..... 8
 - 1.8 TEST CONFIGURATIONS..... 9
- 2. FCC SECTION 2.1046 - RF POWER OUTPUT 11**
 - 2.1 RF POWER OUTPUT..... 11
 - 2.2 EIRP COMPLIANCE 19
 - 2.3 POWER SPECTRAL DENSITY 20
 - 2.4 PEAK-TO-AVERAGE POWER RATIO (PAPR) 25
- 3. FCC SECTION 2.1047 - MODULATION CHARACTERISTICS 28**
 - 3.1 MODULATION CHARACTERISTICS 28
- 4. FCC SECTION 2.1049 – OCCUPIED BANDWIDTH/EDGE OF BAND EMISSIONS 30**
 - 4.1 OCCUPIED BANDWIDTH..... 30
 - 4.2 EDGE OF BAND EMISSIONS 33
- 5. FCC SECTION 2.1051 - SPURIOUS EMISSIONS AT TRANSMIT ANTENNA PORT..... 39**
 - 5.1 SECTION 2.1051 SPURIOUS EMISSIONS AT ANTENNA TERMINALS..... 39
 - 5.2 REQUIRED LIMIT 40
 - 5.3 SPURIOUS EMISSIONS AT ANTENNA TERMINALS RESULTS 41
 - 5.4 SPURIOUS EMISSIONS PLOTS..... 42
- 6. SECTION 2.1053 - MEASUREMENT REQUIRED: FIELD STRENGTH OF SPURIOUS RADIATION 55**
 - 6.1 SPURIOUS RADIATION AND RADIATED EMISSIONS REQUIREMENTS. 55
 - 6.2 FIELD STRENGTH OF SPURIOUS RADIATION RESULTS: 56
- 7. FCC SECTION 2.1055 - MEASUREMENT OF FREQUENCY STABILITY..... 63**
 - 7.1 AC VERSION 63
 - 7.2 DC VERSION..... 72
- 8. PHOTOGRAPHS 80**
- 9. TEST EQUIPMENT 83**
- 10. NVLAP CERTIFICATE OF ACCREDITATION 85**

Revisions

Date	Revision	Section	Change
8/15/2022	0		Initial Release
9/15/2022	1	1.3.1, 1.7.1, 6.1	Revised to include changes due to 25.253(b) emission requirement.
		4.2.1.3, 5.4.3	Added for meeting 25.253(b) emission requirement.
12/19/2022	2	4.2.1.1 & 4.2.1.3	Corrected wrong TM in titles to TM3.2 for 5MHz NR plot in 4.2.1.1 and 5M LTE+5M NR in 4.2.1.3

Nokia Global Product Compliance Laboratories is accredited by the National Voluntary Laboratory Accreditation Program (NVLAP®) for specific services, listed on the Scope of Accreditation, for: Electromagnetic Compatibility and Telecommunications. This laboratory is accredited in accordance with the recognized International Standard ISO/IEC 17025:2017. This accreditation demonstrates technical competence for a defined scope and the operation of a laboratory quality management system (refer to joint ISO-ILAC-IAF Communiqué dated January 2009). NVLAP LAB CODE: 100275-0.

Nokia Global Product Compliance Laboratory represents to the client that the laboratory's accreditation or any of its calibration or test reports in no way constitutes or implies product certification, approval, or endorsement by NVLAP, NIST, or any agency of the U.S. Government.

Prepared By: 
 Signed: _____ 9/15/2022
 Ann Chang
 Compliance Engineer
 NVLAP Signatory
 ann.chang@nokia-bell-labs.com

Reviewed By: 
 Signed: _____ 9/15/2022
 Qin Yu
 EMC Engineer
 NVLAP Signatory
 q.yu@nokia-bell-labs.com

Reviewed By: 
 Signed: _____ 9/15/2022
 Steve Gordon
 EMC Engineer
 NVLAP Signatory
 steve.gordon@nokia-bell-labs.com

Approved By: 
 Signed: _____ 9/15/2022
 Raymond Johnson
 Technical Manager
 NVLAP Signatory
 ray.johnson@nokia-bell-labs.com

1. System Information and Requirements

Report copies and other information not contained in this report are held by either the product engineer or in an identified file at the Global Product Compliance Laboratory in Murray-Hill, NJ.

Equipment Under Test (EUT):	AirScale Micro RRH AWHKB 4T4R B24 8W
Serial Number:	EB2219R1868 (Radio/RE) / EB2219R1872 (Frequency Stability)
FCC ID:	2AD8UAWHKB01
Hardware Version:	476086A.X22 (Radio/ RE) / 476086A.X22 (Frequency Stability)
Software Version:	SBTS22R4
Frequency Range:	1526 - 1536 MHz
GPCL Project Number:	2022-0083
Manufacturer:	NOKIA SOLUTIONS AND NETWORKS OY KARAKAARI 7, FI-02610 ESPOO FINLAND
Applicant:	Nokia Solutions and Networks, OY 200 Lucent Lane Naperville, Illinois 60563
Test Requirement(s):	Title 47 CFR Part25
Test Standards:	Refer to Section 1.5.1
Measurement Procedure(s):	Refer to Section 1.5.2
Test Date(s):	7/13/2022 – 9/15/2022
Test Performed By:	Nokia Global Product Compliance Laboratory 600-700 Mountain Ave. P.O. Box 636 Murray Hill, NJ 07974-0636 Test Site Number: US5302
Product Engineer(s):	Jeff Webb
Lead Engineer:	Steve Gordon
Test Engineer (s):	Greg Manuel, Jaideep Yadav
Test Results: The EUT, <i>as tested</i> met the above listed Test Requirements. The decision rule employed is binary (Pass/Fail) based on the measured values without accounting for Measurement Uncertainty or any Guard Band. The measured values obtained during testing were compared to a value given in the referenced regulation or normative standard. Report copies and other information not contained in this report are held by either the product engineer or in an identified file at the Global Product Compliance Laboratory in New Providence, NJ.	

1.1 Introduction

This Conformity test report applies to the **Nokia AirScale Micro RRH AWHKB 4T4R B24 8W**, hereinafter referred to as the Equipment Under Test (EUT).

1.2 Purpose and Scope

AirScale AWHKB is a variant of 5G/LTE Micro Remote Radio Head (mRRH), operating in B24/n24 with 1526-1536MHz (DL) and 1627.5-1637.5 MHz/1646.5-1656.5 MHz (UL). It supports LTE and NR technologies, 5MHz and 10MHz carriers and 4xMIMOs with 2W per port. AWHKB requires a new FCC certification filing.

This document is to provide the testing data required for qualifying the EUT in compliance with FCC Part 25 measured in accordance with the procedures set out in Section 2.1033 (c) (14) of the Rules.

1.3 EUT Details

1.3.1 Specifications

Specification Items	Description
Product	AirScale Micro RRH AWHKB 4T4R B24
Radio Type	Intentional Transceiver
Power Type	AC & DC
Modulation	QPSK, 16QAM, 64QAM and 256QAM
Operating Frequency Range	1526 – 1536 MHz
Channel Bandwidth	5 & 10 MHz
Maximum Conducted Power	Up to 4x1W for 1x5MHz carrier (30 dBm per port) and 4x1.26W for 1x10MHz or 2x5MHz (31dBm per port) *
Maximum EIRP	10W
Operating Mode	4T4R
Software Version	SBTS22R4
Hardware Version	476086A_X22
Antenna(s)	Refer to Section 1.3.2

*The EUT capacity is 4x2W (33dBm per port). The maximum conducted output power levels allowed will be reduced based on the antennas used and the maximum EIRP 10W limit.

1.3.2 EIRP/ PSD Compliance and Antenna Information.

The product does not incorporate integrated antennas. Externally mounted antennas must be connected to the unit and mounted remotely. This product requires Certified Professional Installation.

25.253(d)(8) specified that applicants for an ancillary terrestrial component in these bands must demonstrate that ATC base stations shall not exceed a peak antenna gain of 16 dBi.

The information on the antennas to be used with the EUT is given below:

Table 3.2.1 Antenna Data from Manufacturers

Ant	Ant Type	Max Gain in Tx Band (dBi)
1	Directional, $\pm 45^\circ$ Cross-polarized	16.0

1.3.3 Photographs

Serial Number

Radio / RE Unit



Frequency Stability



1.4 Test Requirements

Each required measurement is listed below:

47 CFR FCC Sections	Description of Tests	Test Required
2.1046, FCC O&A 20-48 III(H)(2), 25.253(d)(1)(2)	RF Power Output , PSD	Yes
2.1047	Modulation Characteristics	Yes
2.1049, FCC O&A 20-48 III(H)(3), 25.202(f),	(a) Occupied Bandwidth (b) Out-of-Band Emissions	Yes
2.1051, FCC O&A 20-48 III(H)(2), 25.202(f),	Spurious Emissions at Antenna Terminals	Yes
2.105325.202(f), 15 Class B	Field Strength of Spurious Radiation	Yes
2.1055, 25.202(d)	Measurement of Frequency Stability	Yes

1.5 Test Standards & Measurement Procedures

1.5.1 Test Standards

- Title 47 Code of Federal Regulations, Federal Communications Commission Part 2.
- Title 47 Code of Federal Regulations, Federal Communications Commission Part 25.
- FCC 20-48 Order and Authorization, April 19, 2020.
- KDB 273109 D01 Equipment Authorization Guidance for Part 25 Transceivers v02r02 2011.
- KDB 971168 D01 Power Measurement License Digital Systems v03r01 April 9, 2018.
- KDB 662911 D01 Multiple Transmitter Output v02r01 Oct 2013.
- FCC KDB 662911 D02 MIMO with Cross-Polarized Antenna (October 25, 2011) - MIMO with Cross-Polarized Antenna.
- FCC KDB 662911 D03 MIMO with Cross-Polarized Antenna (October 13, 2020) - Provision to Allow Measurement of Directional Gain of Multi-Antenna Systems for Compliance Verification.
- ANSI C63.26-2015, American National Standard for Compliance Testing of Transmitters Used in Licensed Radio Services.
- ANSI C63.4-2014, American National Standard for Methods of Measurement of Radio-Noise Emissions from Low-Voltage Electrical and Electronic Equipment in the Range of 9 kHz to 40 GHz.
- ANSI/TIA/EIA-603-E (2016) - Commercial Mobile Services (FCC Licensed Radio Service Equipment) in 47 CFR FCC Parts 22 (cellular), 24, 25 (below 3 GHz), and 27.

1.5.2 Measurement Procedures

- FCC-IC-OB - GPCL Power Measurement, Occupied Bandwidth & Modulation Test Procedure 6-20-2019
- FCC-IC-SE - GPCL Spurious Emissions Test Procedure 6-20-2019

1.6 MEASUREMENT UNCERTAINTY

The results of the calculations to estimate uncertainties for the several test methods and standards are shown in the Table below. These are the worst-case values.

Worst-Case Estimated Measurement Uncertainties

Standard, Method or Procedure	Condition	Frequency MHz	Expanded Uncertainty (k=2)
a. Classical Emissions, (e.g., ANSI C63.4, CISPR 11, 14, 32, etc., using ESHS 30,	Conducted Emissions	0.009 - 30	±3.5 dB
	Radiated Emissions (AR-6 Semi-Anechoic Chamber)	30 MHz – 200MHz H 30 MHz – 200 MHz V 200 MHz – 1000 MHz H 200 MHz – 1000 MHz V 1 GHz - 18 GHz	±5.1 dB ±5.1 dB ±4.7 dB ±4.7 dB ±3.3 dB

Antenna Port Test	Signal Bandwidth	Frequency Range	Expanded Uncertainty (k=2), Amplitude
Occupied Bandwidth, Edge of Band, Conducted Spurious Emissions	10 Hz	9 kHz to 20 MHz	1.78 dB
	100 Hz	20 MHz to 1 GHz	
	10 kHz to 1 MHz	1 GHz to 10 GHz	
	1MHz	10 GHz to 40 GHz:	
RF Power	10 Hz to 20 MHz	50 MHz to 18 GHz	0.5 dB

1.7 Executive Summary

Requirement 47 CFR FCC Parts 2 and 96	Description of Tests	Result
2.1046, FCC O&A 20-48 III(H)(2), 25.253(d)(1)(2)	RF Power Output, PSD	COMPLIES
2.1047	Modulation Characteristics	COMPLIES
2.1049, FCC O&A 20-48 III(H)(3), 25.202(f), 25.253(b)	(a) Occupied Bandwidth (b) Out-of-Band Emissions	COMPLIES
2.1051, FCC O&A 20-48 III(H)(2), 25.202(f), 25.253(b)	Spurious Emissions at Antenna Terminals	COMPLIES
2.1053, 25.202(f), 25.253(b), Class B	Field Strength of Spurious Radiation	COMPLIES
2.1055, 25.202(d)	Measurement of Frequency Stability	COMPLIES

1. **COMPLIES** - Passed all applicable tests.
2. **N/A** – Not Applicable.
3. **NT** – Not Tested.

1.8 Test Configurations

Test Setup for all Antenna Port Measurements

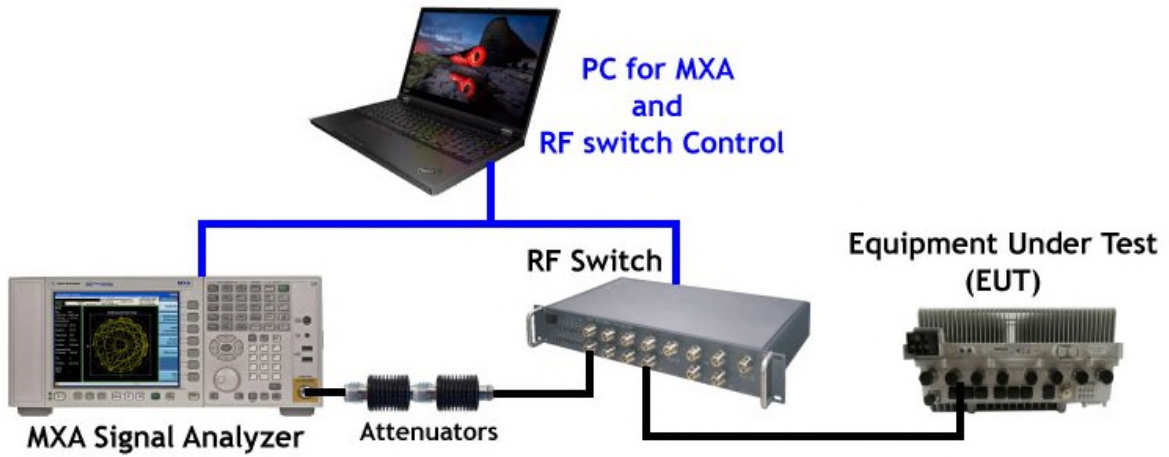

Test Setup for Frequency Stability

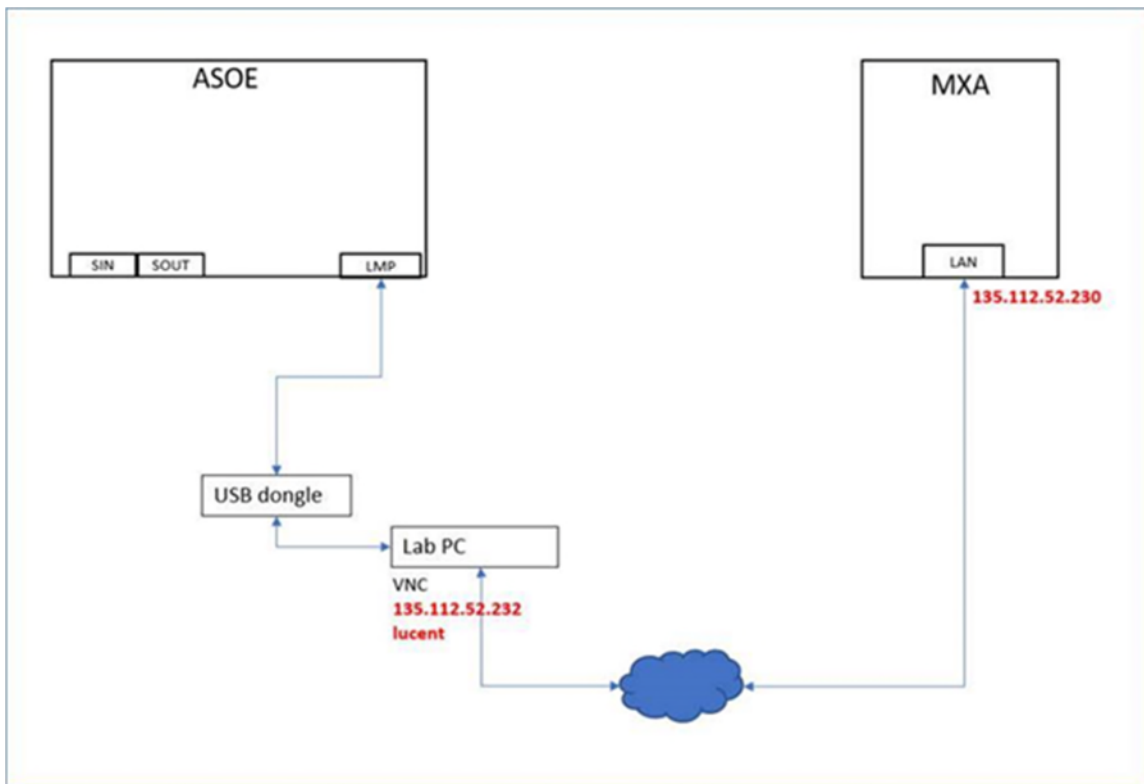
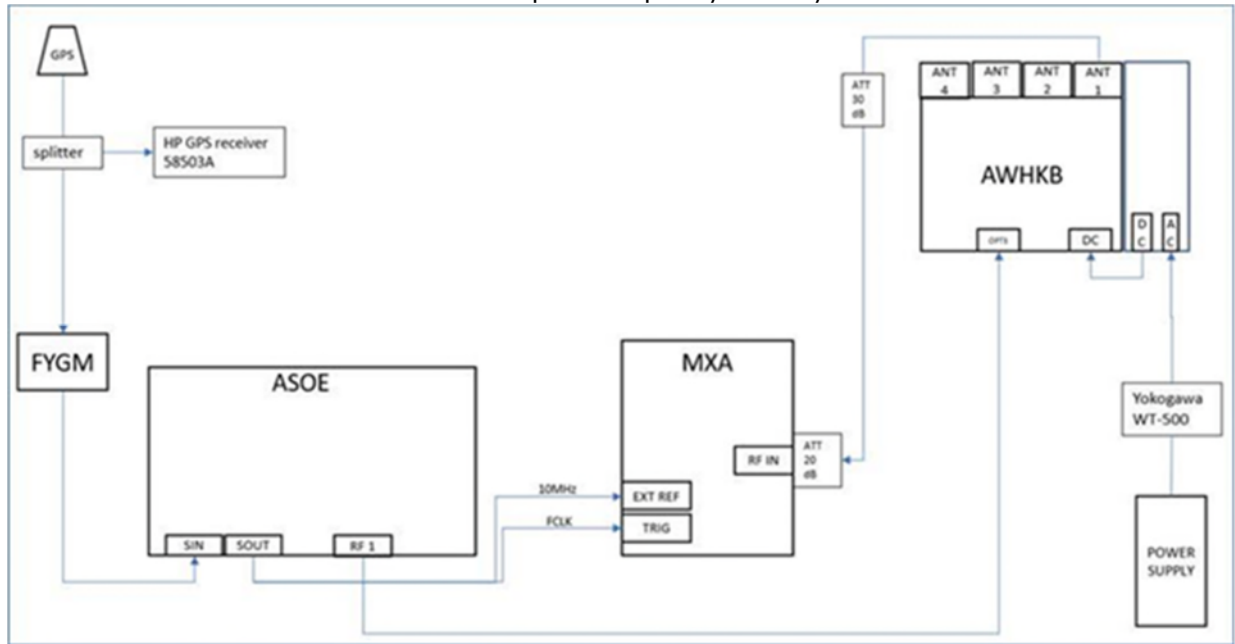

2. FCC Section 2.1046 - RF Power Output

2.1 RF Power Output

This test is a measurement of the total RF power level transmitted at the antenna-transmitting terminal. The product was allowed to warm up and stabilize per KDB 971168 D01 and ANSI C63.26.

The RF power measurements were done under the following power setting per port:

- LTE (5 & 10 MHz BW); 33dBm
- 5G-NR (5 & 10 MHz BW); 33, 27.5, and 24.5 dBm
- 5G-NR+ LTE (5+5 MHz BW); 33dBm

The power is under digital control. The product is designed to operate under FCC 20-48 O&A, Part 25 rules for Band 24.

Under FCC 20-48 O&A the product is limited to the maximum EIRP of 9.8 dBW or 10W.

The unit is supplied with externally mounted $\pm 45^\circ$ Cross-polarized directional antennas with a maximum gain up to 16.0 dBi.

The conducted output power levels tested were the maximum power supported and the real power output in the field will be reduced based on the antennas used and the maximum EIRP 10W limit.

2.1.1 RF Power Output Measurements

Power measurements of the LTE and NR transmit signal were conducted with an MXA Signal analyzer per KDB 971168 D01 using the gated RF Channel Power Function.

2.1.2 RF Power Output Results

Table 2.1a - RF Power - 1C LTE 33dBm

Channel Power -5 MHz				Channel Power -10 MHz	
Test Model 3.1 Modulation 64QAM Channel Frequency 1528.5 MHz		Test Model 3.1a Modulation 256QAM Channel Frequency 1533.5 MHz		Test Model 3.1 Modulation 64QAM Channel Frequency 1531 MHz	
TX Port	(dBm)	TX Port	(dBm)	TX Port	(dBm)
1	33.23	1	33.50	1	33.52
2	33.00	2	32.95	2	32.88
3	33.03	3	33.13	3	33.08
4	32.85	4	32.94	4	32.84
Total Power (dBm)	39.05	Total Power (dBm)	39.16	Total Power (dBm)	39.11
Total Power (W)	8.04	Total Power (W)	8.23	Total Power (W)	8.15

Table 2.1b - RF Power - 1C 5G-NR 33dBm

Channel Power -5 MHz				Channel Power -10 MHz	
Test Model 3.1 Modulation 64QAM Channel Frequency 1528.5 MHz		Test Model 3.1a Modulation 256QAM Channel Frequency 1533.5 MHz		Test Model 3.1 Modulation 64QAM Channel Frequency 1531 MHz	
TX Port	(dBm)	TX Port	(dBm)	TX Port	(dBm)
1	33.24	1	33.24	1	33.26
2	32.86	2	33.03	2	32.96
3	32.76	3	33.03	3	33.22
4	32.62	4	32.82	4	33.02
Total Power (dBm)	38.9	Total Power (dBm)	39.05	Total Power (dBm)	39.14
Total Power (W)	7.76	Total Power (W)	8.04	Total Power (W)	8.20

Table 2.1c - RF Power - 1C 5G-NR 27.5dBm

Channel Power -5 MHz				Channel Power -10 MHz	
Test Model 3.2 Modulation QPSK/16QAM Channel Frequency 1528.5 MHz		Test Model 3.1a Modulation 256QAM Channel Frequency 1533.5 MHz		Test Model 3.1 Modulation 64QAM Channel Frequency 1531 MHz	
TX Port	(dBm)	TX Port	(dBm)	TX Port	(dBm)
1	27.50	1	27.40	1	27.75
2	27.08	2	27.16	2	27.47
3	27.16	3	27.23	3	27.62
4	27.04	4	27.01	4	27.41
Total Power (dBm)	33.22	Total Power (dBm)	33.22	Total Power (dBm)	33.59
Total Power (W)	2.10	Total Power (W)	2.10	Total Power (W)	2.28

Table 2.1d - RF Power - 1C 5G-NR 24.5dBm

Channel Power -5 MHz				Channel Power -10 MHz	
Test Model 3.1 Modulation 64QAM Channel Frequency 1528.5 MHz		Test Model 3.1a Modulation 256QAM Channel Frequency 1533.5 MHz		Test Model 3.1 Modulation 64QAM Channel Frequency 1531 MHz	
TX Port	(dBm)	TX Port	(dBm)	TX Port	(dBm)
1	24.99	1	24.50	1	24.62
2	24.62	2	24.35	2	24.35
3	24.64	3	24.36	3	24.51
4	24.40	4	24.08	4	24.49
Total Power (dBm)	30.69	Total Power (dBm)	30.35	Total Power (dBm)	30.51
Total Power (W)	1.17	Total Power (W)	1.08	Total Power (W)	1.13

Table 2.1e - RF Power - 2C 5G-NR+LTE 33dBm

Channel Power - NR+LTE / 5+5 MHz	
Test Model 3.1a Modulation 256QAM Channel Frequency 1528.5 +1533.5 MHz	
TX Port	(dBm)
1	33.59
2	33.11
3	34.25
4	33.42
Total Power (dBm)	39.63
Total Power (W)	9.19

2.1.3 Maximum RF Conducted Output Power Plots

RF Power - 1C LTE 33dBm

Test Model 3.1
Modulation 64QAM
Channel Frequency 1528.5 MHz
TX1, 5MHz BW

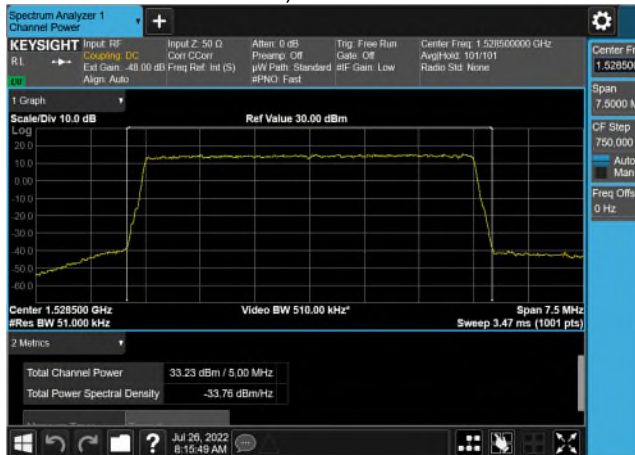

Test Model 3.1a
Modulation 256QAM
Channel Frequency 1533.5 MHz
TX1, 5MHz BW

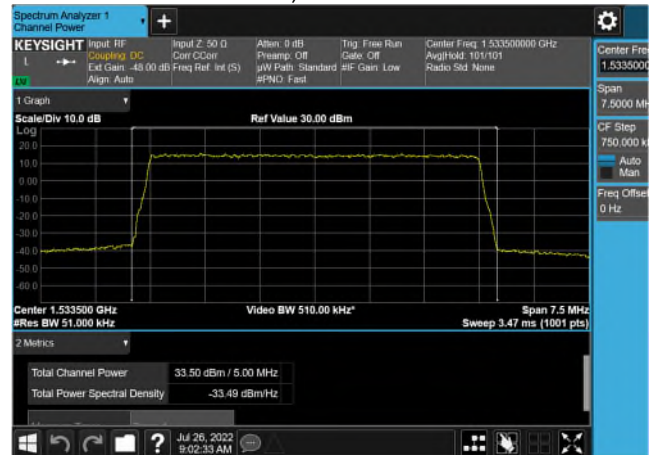

Test Model 3.1
Modulation 64QAM
Channel Frequency 1531 MHz
TX1, 10MHz BW

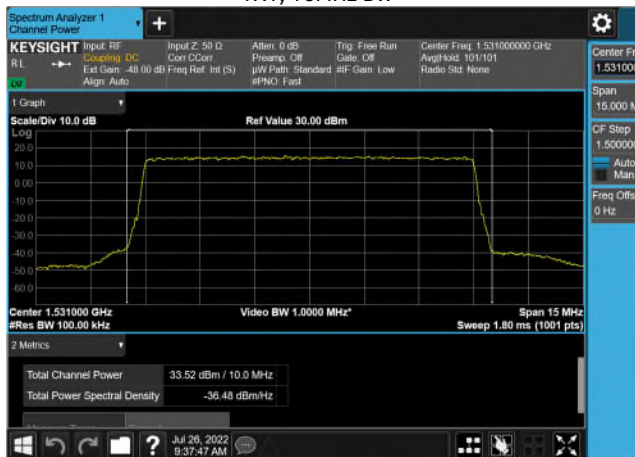

RF Power - 1C 5G-NR 33dBm

Test Model 3.1
Modulation 64QAM
Channel Frequency 1528.5 MHz
TX1, 5MHz BW

Test Model 3.1a
Modulation 256QAM
Channel Frequency 1533.5 MHz
TX1, 5MHz BW



Test Model 3.1
Modulation 64QAM
Channel Frequency 1531 MHz
TX1, 10MHz BW

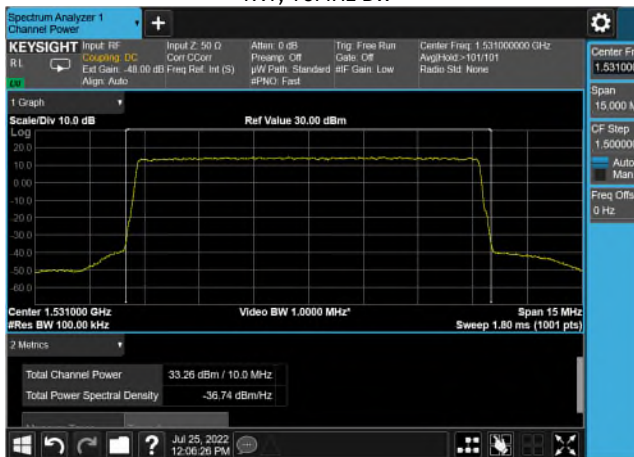

RF Power - 1C 5G-NR 27.5dBm

Test Model 3.2
Modulation QPSK/16QAM
Channel Frequency 1528.5 MHz
TX1, 5MHz BW

Test Model 3.1a
Modulation 256QAM
Channel Frequency 1533.5 MHz
TX1, 5MHz BW

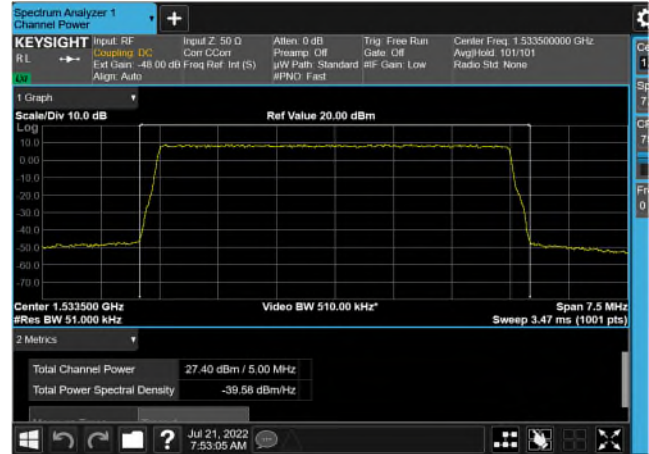
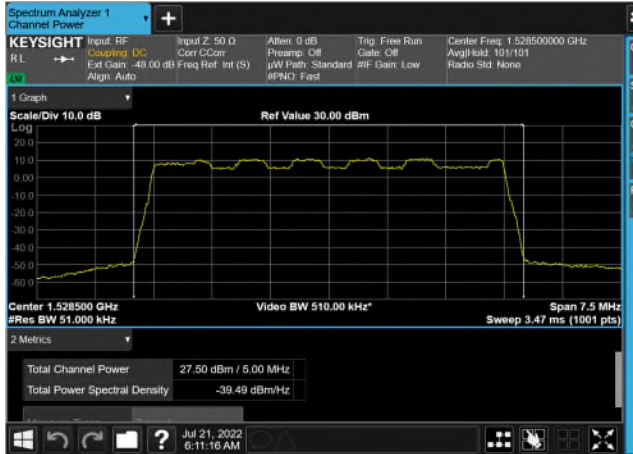

Test Model 3.1
Modulation 64QAM
Channel Frequency 1531 MHz
TX1, 10MHz BW

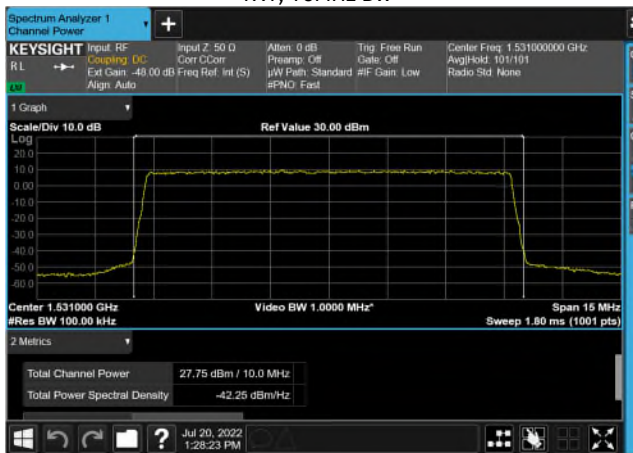

RF Power - 1C 5G-NR 24.5dBm

Test Model 3.1
Modulation 64QAM
Channel Frequency 1528.5 MHz
TX1, 5MHz BW



Test Model 3.1a
Modulation 256QAM
Channel Frequency 1533.5 MHz
TX1, 5MHz BW

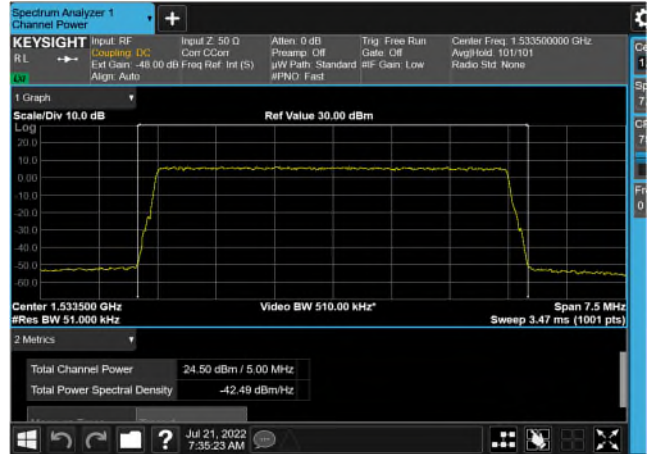

Test Model 3.1
Modulation 64QAM
Channel Frequency 1531 MHz
TX1, 10MHz BW

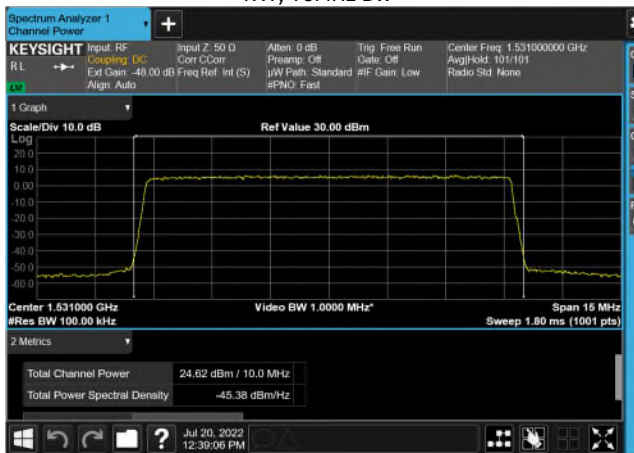

RF Power - 2C 5G-NR+LTE 33dBm

Test Model 3.1a

Modulation 256QAM

Channel Frequency 1528.5 +1533.5 MHz

TX3, 5+5 MHz BW

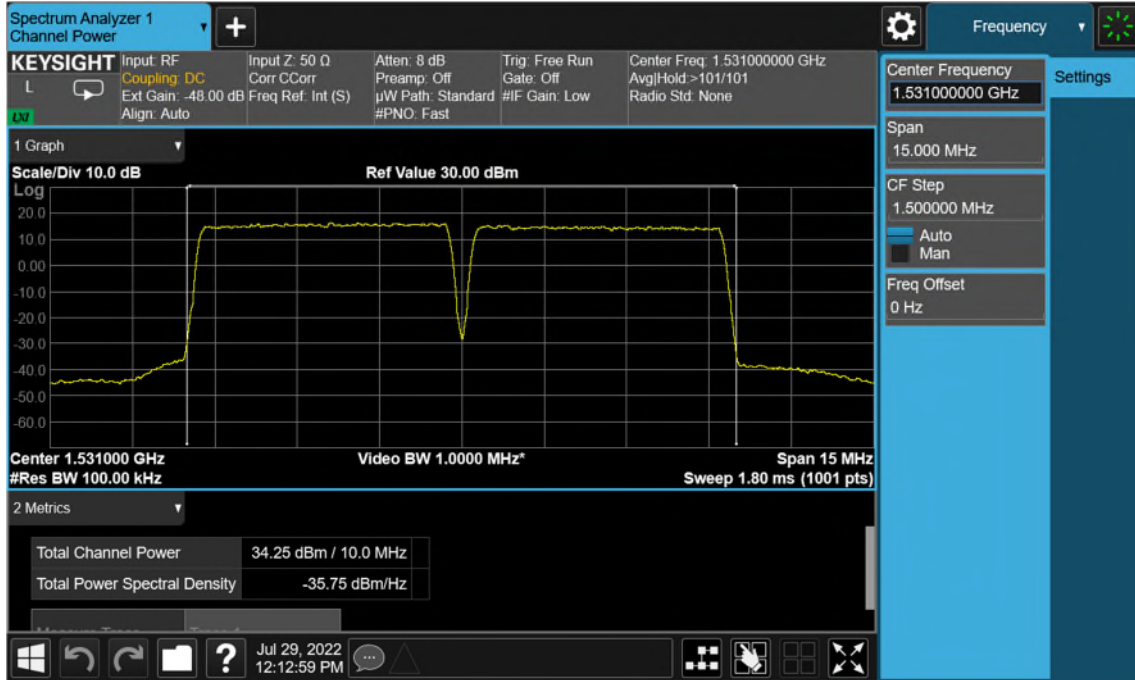

2.2 EIRP Compliance

Under FCC 20-48 O&A, the product is limited to the maximum EIRP of 9.8 dBW or 10W. Compliance with the EIRP requirements is tabulated in Table 2.2 below.

In the event the antenna gain path loss is less than what listed in the table, the output power setting will be reduced in order to stay within the EIRP limits for the band.

Table 2.2 Effective Isotropically Radiated Power (EIRP) Compliance

Output Power Setting	Maximum Total 4x MIMO Transmit Power	EIRP Limit	Maximum Permissible Antenna Gain + Pathloss*	EIRP Compliance
dBm	dBm	dBm	dB	Pass/Fail
33	39.63	39.8	0.17	Pass
27.5	33.59	39.8	6.21	Pass
24.5	30.69	39.8	9.11	Pass

- If Maximum Antenna Gain and Installation Pathloss (Cabling loss) exceeds this value, the product Output Power Setting must be reduced for compliance to be maintained.
- With a 16dBi antenna, the maximum allowed transmit power at the antenna terminal is 23.8dBm total or 17.8dBm per port.

2.3 Power Spectral Density

The Power Spectral Density (PSD) of the EUT was measured per KDB 971168 D01 the Channel Power Measurement feature of the MXA Analyzer. The signal bandwidths, modulations and transmit channels identified in Table 2.3 were evaluated.

47CFR 25.253(d)(1)(2) specified that:

(d) Applicants for an ancillary terrestrial component in these bands must demonstrate that ATC base stations shall not:

(1) Exceed a peak EIRP of $31.9 - 10 \cdot \log(\text{number of carriers})$ dBW/200kHz, per sector, for each carrier in the 1525-1541.5 MHz and 1547.5-1559 MHz frequency bands.

(2) Exceed an EIRP in any direction toward the physical horizon (not to include man-made structures) of $26.9 - 10 \cdot \log(\text{number of carriers})$ dBW/200 kHz, per sector, for each carrier in the 1525-1541.5 MHz and 1547.5-1559 MHz frequency bands.

No of Carriers	Peak EIRP PSD Limit		EIRP PSD Horizontal Direction Limit	
	dBW/200kHz	dBm/200kHz	dBW/200kHz	dBm/200kHz
1C	31.9	61.9	26.9	56.9
2C	28.9	58.9	23.9	53.9

With the maximum 16dBi antenna gain and 4xMIMO, the above limits will be revised by:

$$-16 \text{ dBi} - 10 \cdot \log(4) + 10 \cdot \log(1000\text{kHz}/200\text{kHz}) = -22 + 7 = -15 \text{ dB}$$

No of Carriers	Maximum Conducted PSD Limit per Port
	dBm/MHz
1C	41.9
2C	38.9

2.3.1 Results

The maximum Power Spectral Density (PSD) of the EUT measured at its antenna transmitting terminals were measured to be 27.49 dBm/MHz plus 6.02 dBm adjustment for 4 ports. The measured values are in Table 2.3 below.

Table 2.3 Power Spectral Density Results

# of Carriers	Test Model	Modulation	TX Port	Channel Frequency MHz	Signal BW MHz	Radio Access Technology	Power dBm	PSD (PK Ave) dBm/MHz
1	3.1	64QAM	1	1528.5	5	LTE	33	26.93
1	3.1a	256QAM	1	1533.5	5	LTE	33	26.17
1	3.1	64QAM	1	1531	10	LTE	33	24.68
1	3.2	QPSK/16QAM	1	1528.5	5	5G-NR	33	27.49
1	3.1a	256QAM	1	1533.5	5	5G-NR	33	27.24
1	3.2	QPSK/16QAM	1	1528.5	5	5G-NR	27.5	21.42
1	3.1a	256QAM	1	1533.5	5	5G-NR	27.5	21.24
1	3.1	64QAM	1	1531	10	5G-NR	27.5	18.45
1	3.1	64QAM	1	1528.5	5	5G-NR	24.5	18.69
1	3.1a	256QAM	1	1533.5	5	5G-NR	24.5	18.04
1	3.1	64QAM	1	1531	10	5G-NR	24.5	15.4
2	1.1	QPSK	1	1528.5+1533.5	5+5	5G-NR+LTE	33	24.47

2.3.2 Power Spectral Density Plots

PSD – 1C LTE 33dBm
Test Model 3.1
Modulation 64QAM
Channel Frequency 1528.5 MHz
TX1, 5MHz BW



PSD – 2C 5G-NR+LTE 33dBm
Test Model 3.1a
Modulation 256QAM
Channel Frequency 1528.5 +1533.5 MHz
5+5 MHz BW



PSD - 1C 5G-NR

33dBm
Test Model 3.1
Modulation 64QAM
Channel Frequency 1528.5 MHz
TX1, 5MHz BW

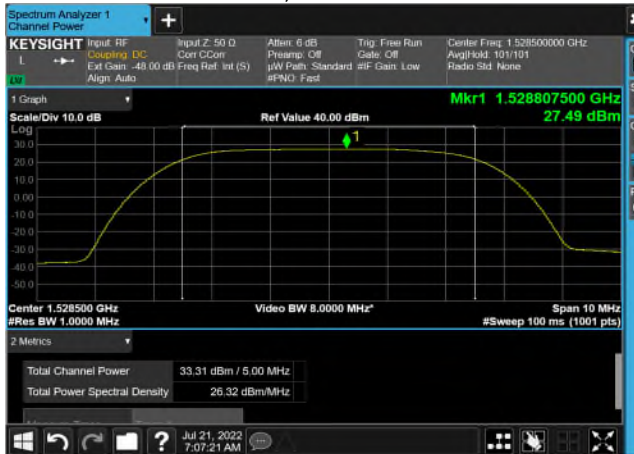

27.5dBm
Test Model 3.2
Modulation QPSK/16QAM
Channel Frequency 1528.5 MHz
TX1, 5MHz BW

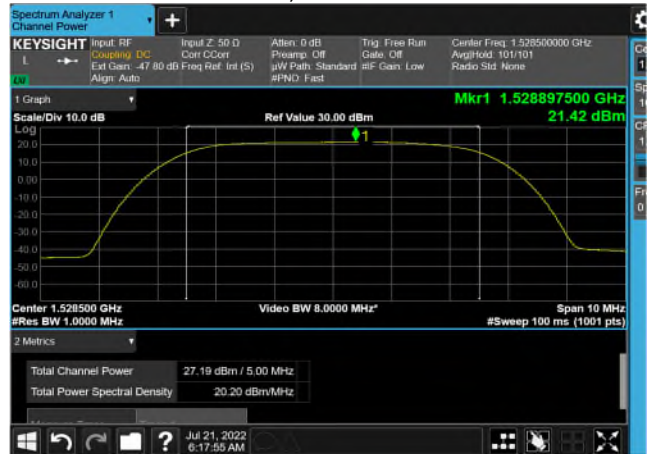

24.5dBm
Test Model 3.1
Modulation 64QAM
Channel Frequency 1528.5 MHz
TX1, 5MHz BW

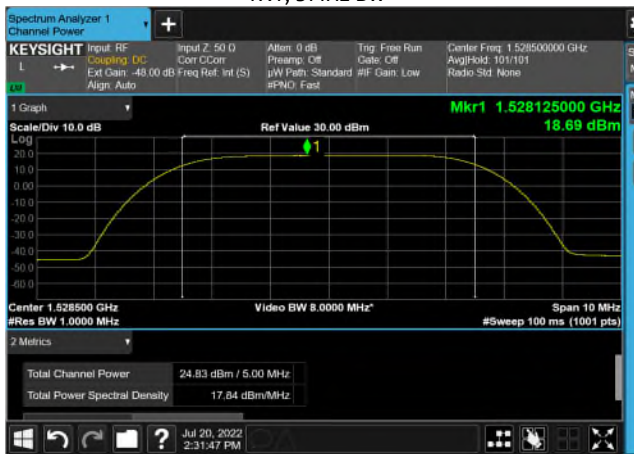

PSD – 2C 5G-NR+LTE 33dBm
Test Model 3.1a
Modulation 256QAM
Channel Frequency 1528.5 +1533.5 MHz
5+5 MHz BW



2.4 Peak-to-Average Power Ratio (PAPR)

The Peak-to-Average Power Ratio (PAPR) of the EUT was measured per KDB 971168 D01 using the Power Complementary Cumulative Distribution Function (CCDF) feature of the MXA Analyzer. The PAPR measurements are tabulated in Table 2.4.

Often it is expected that the transmitter’s peak-to-average power ratio (PAPR) shall not exceed 13 dB for more than 0.1% of the time using a signal corresponding to the highest PAPR during periods of continuous transmission. The maximum PAPR value for each measured configuration is given in Table 2.4.

The data presented in this section is for information only.

2.4.1 Peak-to-Average Power Ratio Results:

The maximum Peak-to-Average Power Ratio (PAPR) of the EUT measured at its antenna transmitting terminals was measured to be 8.38dB maximum, which is in full compliance with the requirement to not exceed 13 dB as specified by the FCC. The representative data sets exact values are listed in Table 2.4 below.

Table 2.4 Peak to Average Power Ratio

# of Carriers	Test Model	Modulation	TX Port	Channel Frequency MHz	Signal BW MHz	Radio Access Technology	Power dBm	PAR at 0.1% Limit - 13 dB
1	3.1	64QAM	1	1528.5	5	LTE	33	8.2
1	3.1a	256QAM	1	1533.5	5	LTE	33	8.22
1	3.1	64QAM	1	1531	10	LTE	33	8.24
1	3.2	QPSK/16QAM	1	1528.5	5	5G-NR	33	8.22
1	3.1a	256QAM	1	1533.5	5	5G-NR	33	8.29
1	3.1	64QAM	1	1531	10	5G-NR	33	8.11
1	3.2	QPSK/16QAM	1	1528.5	5	5G-NR	27.5	8.26
1	3.1a	256QAM	1	1533.5	5	5G-NR	27.5	8.38
1	3.1	64QAM	1	1531	10	5G-NR	27.5	8.3
1	3.1	64QAM	1	1528.5	5	5G-NR	24.5	8.33
1	3.1a	256QAM	1	1533.5	5	5G-NR	24.5	8.38
1	3.1	64QAM	1	1531	10	5G-NR	24.5	8.29
2	1.1	QPSK	1	1528.5+1533.5	5+5	5G-NR+LTE	33	8.02

2.4.2 Peak-to-Average Power Ratio Plots

5G-NR 27.5 dBm
Test Model 3.1a
Modulation 256QAM
Channel Frequency 1533.5 MHz
5 MHz BW

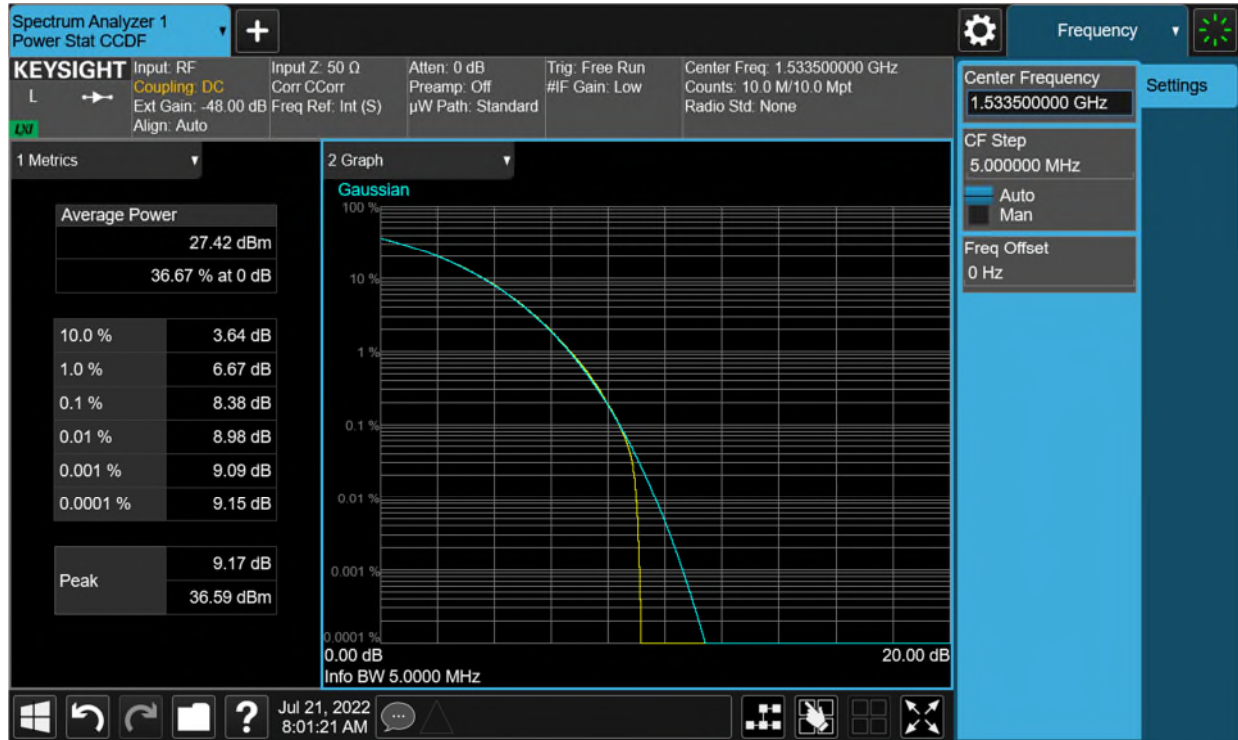

5G-NR 24.5 dBm
Test Model 3.1a
Modulation 256QAM
Channel Frequency 1533.5 MHz
5 MHz BW



3. FCC Section 2.1047 - Modulation Characteristics

3.1 Modulation Characteristics

The RF signal at the antenna port was demodulated and verified for correctness of the modulation signal used before each test was performed.

3.1.1 Modulation Characteristics – Plots

**Modulation QPSK TM1.1
Center Frequency 1531 MHz, LTE, 10MHz BW**

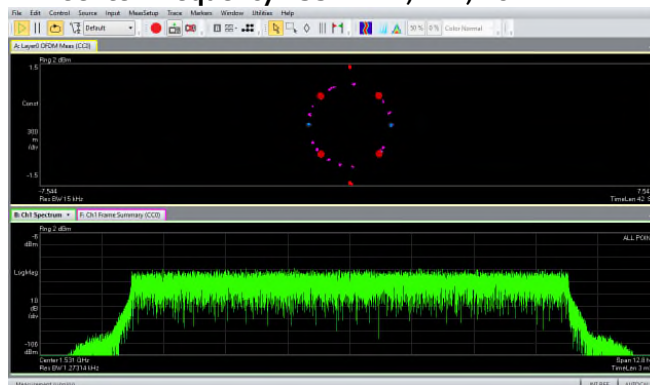

**Modulation 64QAM TM3.1
Center Frequency 1531MHz, LTE, 10 MHz BW**

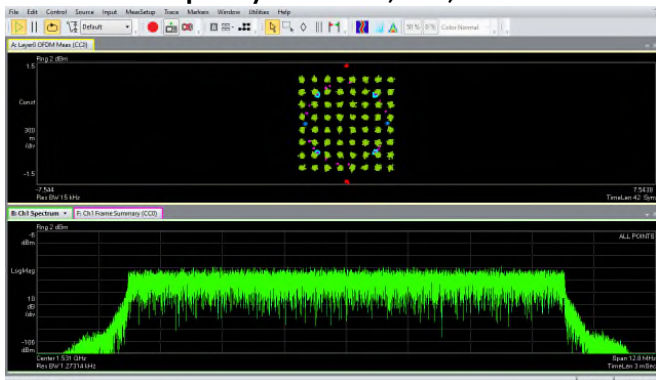

Center Frequency 1533.5MHz, 5G-NR, 5 MHz BW

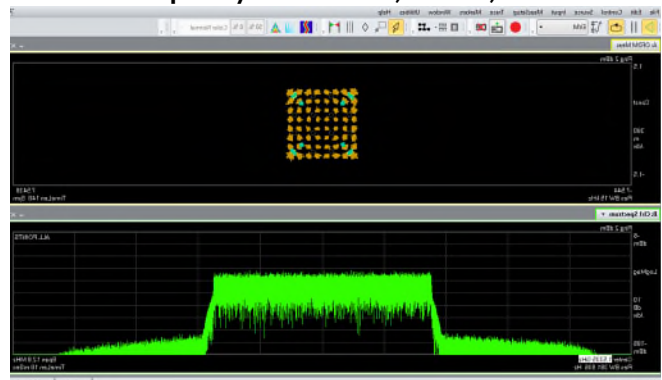

Modulation 256QAM TM3.1a

Center Frequency 1531MHz, LTE, 10 MHz BW

Center Frequency 1533.5MHz, 5G-NR, 5 MHz BW

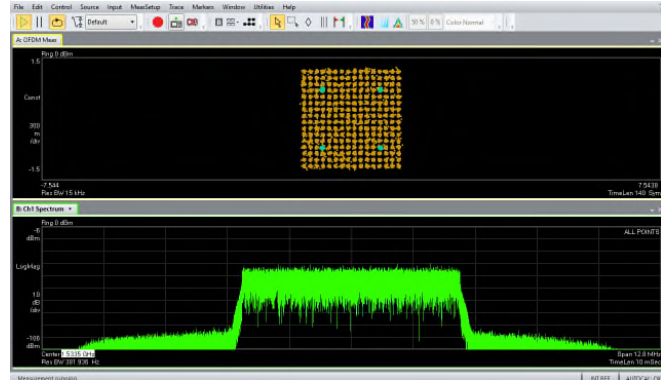
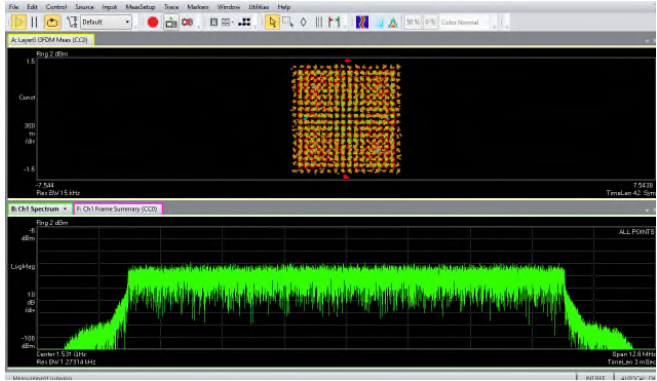

Modulation QPSK/16QAM TM3.2

Center Frequency 1531MHz, LTE, 10 MHz BW

Center Frequency 1533.5MHz, 5G-NR, 5 MHz BW

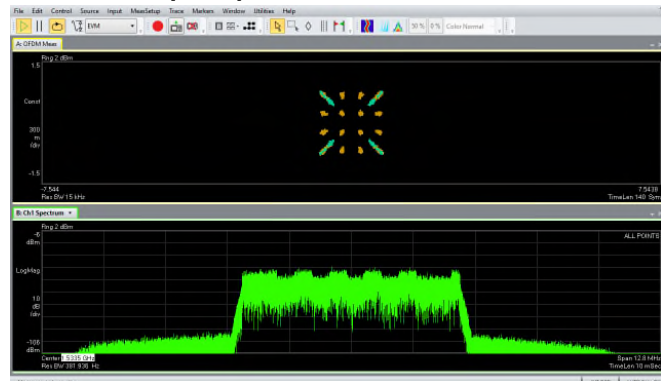
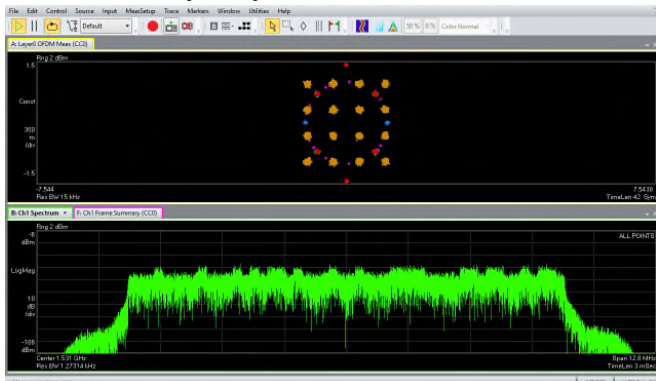

4. FCC Section 2.1049 – Occupied Bandwidth/Edge of Band Emissions

4.1 Occupied Bandwidth

In 47CFR 2.1049 the FCC requires:

“The occupied bandwidth, that is the frequency bandwidth such that, below its lower and above its upper frequency limits, the mean powers radiated are each equal to 0.5 percent of the total mean power radiated by a given emission shall be measured under the following conditions as applicable.”

This required measurement is the 99% Occupied Bandwidth, also called the designated signal bandwidth and needs to be within the parameters of the products specified emissions designator. During these measurements it is customary to evaluate the Edge of Band emissions at block/band edges.

The transmitted signal occupied bandwidth was measured using a Keysight MXA Signal Analyzer. All emissions were within the parameters as required.

4.1.1 Occupied Bandwidth (Signal Bandwidth) Results

The 99% occupied bandwidth and -26 dB relative bandwidth were measured with an Agilent/Keysight MXA signal analyzer for the emission designators. The results are tabulated in Table 4.1 and example plots are in section 4.1.2.

Table 4.1: Occupied Bandwidth

# of Carriers	Test Model	Modulation	TX Port	Channel Frequency MHz	Signal BW MHz	Radio Access Technology	Power dBm	99% Occupied BW MHz	26dB BW MHz
1	3.1	64QAM	1	1528.5	5	LTE	33	4.4731	4.773
1	3.1a	256QAM	1	1533.5	5	LTE	33	4.4765	4.77
1	3.1	64QAM	1	1531	10	LTE	33	8.9281	9.452
1	3.2	QPSK/16QAM	1	1528.5	5	5G-NR	33	4.4808	4.725
1	3.1a	256QAM	1	1533.5	5	5G-NR	33	4.4485	4.753
1	3.1	64QAM	1	1531	10	5G-NR	33	9.2678	9.721
1	3.2	QPSK/16QAM	1	1528.5	5	5G-NR	27.5	4.4735	4.738
1	3.1a	256QAM	1	1533.5	5	5G-NR	27.5	4.4619	4.761
1	3.1	64QAM	1	1531	10	5G-NR	27.5	9.2418	9.731
1	3.1	64QAM	1	1528.5	5	5G-NR	24.5	4.4636	4.75
1	3.1a	256QAM	1	1533.5	5	5G-NR	24.5	4.4634	4.746
1	3.1	64QAM	1	1531	10	5G-NR	24.5	9.2743	9.717
2	1.1	QPSK	1	1528.5+1533.5	5+5	5G-NR+LTE	33	9.4225	9.827

4.1.2 Occupied Bandwidth – Plots

1C – LTE 5MHz
Test Model 3.1
Modulation 64QAM
Channel Frequency 1528.5 MHz

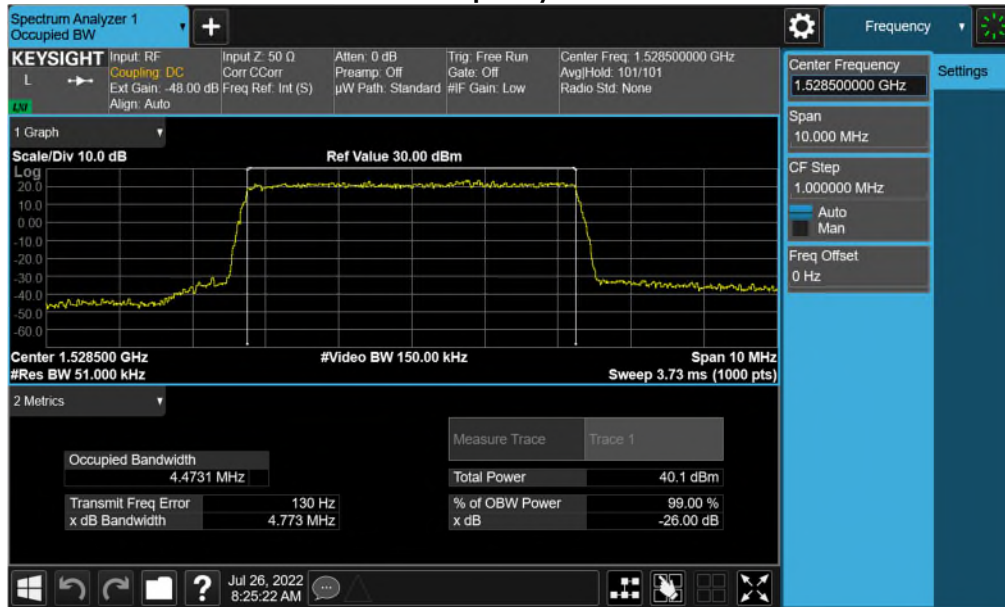

1C – 5G-NR 33dBm 5MHz
Test Model 1.1
Modulation QPSK
Channel Frequency 1528.5 MHz

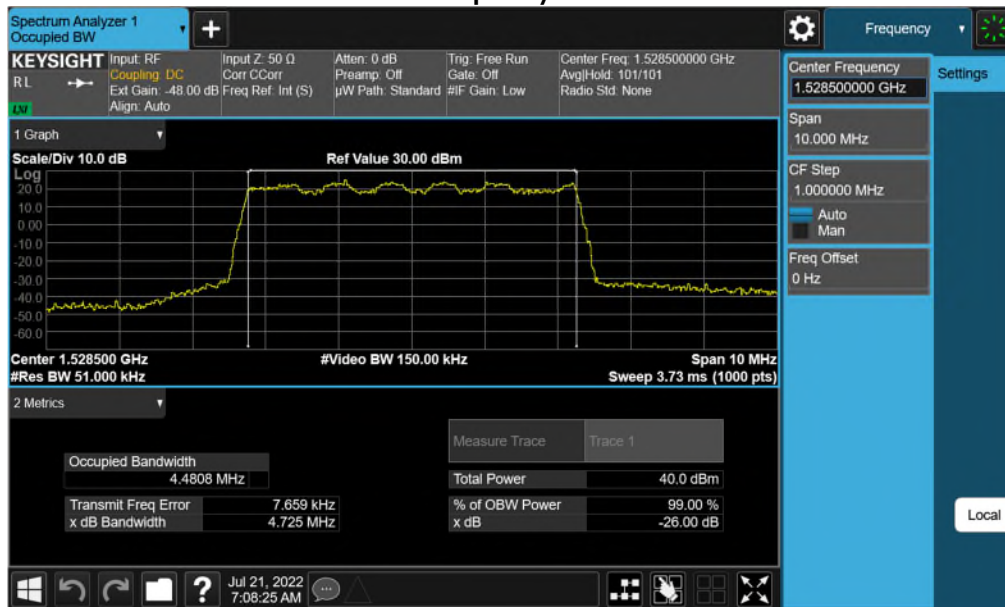

2C – 5G NR+LTE
Test Model 3.1
Modulation 64QAM
Channel Frequency 1528.5+1533.5 MHz

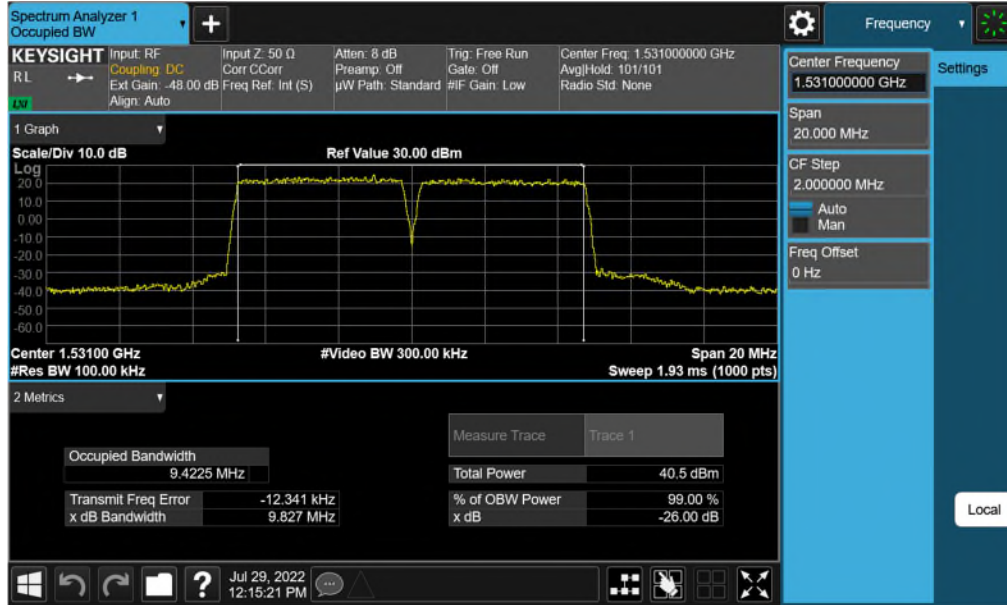

4.2 Edge of Band Emissions

FCC 20-48 O&A specified out-of-emissions limits for ATC (Ancillary Terrestrial Component) base stations in Section III(H)(3) as below:

EIRP limit

- (i) -55 dBm/MHz in the 1541-1559 MHz and 1610-1650 MHz frequency ranges;
- (ii) -70 dBm/MHz in the 1559-1610 MHz frequency range.

Discrete Emissions

- (i) -82 dBm/2 kHz in the 1541-1559 MHz frequency range;
- (ii) -80 dBm/700 Hz in the 1559-1610 MHz frequency range;
- (iii) -65 dBm/700 Hz in the 1610-1650 MHz frequency range.

47CFR 25.202(f) specified that the mean power of emissions shall be attenuated below the mean output power of the transmitter in accordance with the schedule set forth in paragraphs (f)(1) through (f)(4).

- (1) In any 4 kHz band, the center frequency of which is removed from the assigned frequency by more than 50 percent up to and including 100 percent of the authorized bandwidth: 25 dB;
- (2) In any 4 kHz band, the center frequency of which is removed from the assigned frequency by more than 100 percent up to and including 250 percent of the authorized bandwidth: 35 dB;
- (3) In any 4 kHz band, the center frequency of which is removed from the assigned frequency by more than 250 percent of the authorized bandwidth: An amount equal to 43 dB plus 10 times the logarithm (to the base 10) of the transmitter power in watts;
- (4) In any event, when an emission outside of the authorized bandwidth causes harmful interference, the Commission may, at its discretion, require greater attenuation than specified in paragraphs (f) (1), (2) and (3) of this section.

Per KDB 662911 D02, for correlated signals with cross-polarization, the combined EIRPs will meet the EIRP limits. For 4xMIMO, the adjustment for port limit is $10\log(4) = 6.02$.

Table 4.2(a) FCC 20-48 O&A Emission Limits

Frequency Range	EIRP Emission Limits	Conducted Limits per Port*
1541-1559, 1610-1650	-55 dBm/MHz	-61.5 dBm/MHz
1559-1610	-70 dBm/MHz	-76.5 dBm/MHz
1541-1559	-82 dBm/2kHz	-88.5 dBm/2kHz
1559-1610	-80 dBm/700 Hz	-86.5 dBm/700 Hz
1610-1650	-65 dbm/700 hz	-71.5 dBm/700 Hz

*Assuming zero antenna gain here.

Table 4.2(b) 25.202(f) Emission Limits for 33dBm/Per Port

BW (MHz)	f _c Carrier (MHz)	Emission Limits Per Port (in 4kHz)								
		Δf from f _c 50% -100% BW			Δf from f _c 100% -250% BW			Δf from f _c >250% BW		
		f (MHz)	dBc	dBm	f (MHz)	dBc	dBm	f (MHz)	dBc	dBm
5	1528.5	1523.5-1526	-25	-23	1516-1523.5	-35	-33	<1516	-21.1	-19
	1526-1531	1531-1533.5			1533.5-1541			>1541		
	1533.5	1528.5-1531	-25	-23	1521-1528.5	-35	-33	<1521	-21.1	-19
	1531-1536	1536-1538.5			1538.5-1541			>1546		
10	1531	1521-1526	-25	-26	1506-1521	-35	-36	<1506	-18	-19
	1526-1536	1536-1541			>1556					

47CFR 25.253(b) specified that ATC base stations shall not exceed an out-of-channel emissions measurement of -57.9 dBW/MHz at the edge of a MSS (Mobile-Satellite Service) licensee's authorized and *internationally coordinated* MSS frequency assignment. It is equal to -27.9dBm/MHz total and -33.9dBm/MHz per port.

The Edge of Band emissions of the EUT at the external antenna connector (EAC) were measured using a Keysight MXA Signal Analyzer. The RF power level was continuously measured using a RF broadband power meter. The RF output from the EAC port to signal analyzer was reduced (to an amplitude usable by the signal analyzer) by using a calibrated attenuator and test coupler. The path attenuation was offset on the display and the signal for the carrier was adjusted to the corrected RF power level for the resolution bandwidth used for the transmit signal. All mask values were adjusted based upon the designated signal bandwidth and measurement bandwidths.

4.2.1 Edge of Band Emissions - Plots

4.2.1.1 25.202(f) Emission Compliance

The minimum margin is 18.51dB. All of the measured data met the 25.202(f) requirements. The spurious emissions of the EUT transmitting at 33dBm output power per port (maximum available power) met the requirements. Therefore, the spurious emissions of the EUT meet the 25.202(f) requirements.

Edge of Band Emission - 1C LTE

Test Model 3.1 Modulation 64QAM
 Channel Frequency 1528.5 MHz
 TX1, 5MHz BW Narrow Mask

Test Model 3.1a Modulation 256QAM
 Channel Frequency 1533.5 MHz
 TX1, 5MHz BW Narrow Mask



Test Model 3.1 Modulation 64QAM
 Channel Frequency 1531 MHz
 TX1, 10MHz BW

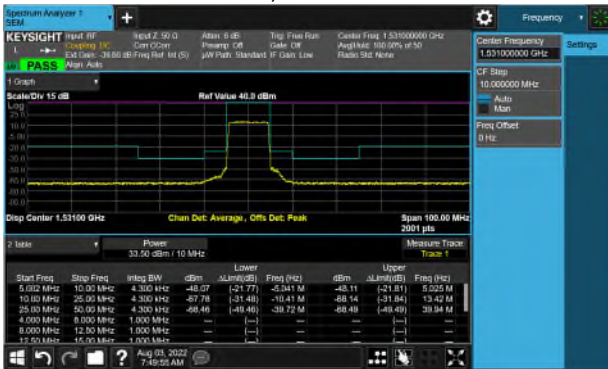

Edge of Band Emission - 1C 5G-NR 33dBm

Test Model 3.2 Modulation QPSK+16QAM
 Channel Frequency 1528.5 MHz
 TX1, 5MHz BW Narrow Mask

Test Model 3.1a Modulation 256QAM
 Channel Frequency 1533.5 MHz
 TX1, 5MHz BW Narrow Mask



Test Model 3.1 Modulation 64QAM
 Channel Frequency 1531 MHz
 TX1, 10MHz BW



Edge of Band Emission - 2C 5G-NR+LTE

Test Model 3.1a
 Modulation 256QAM
 Channel Frequency 1528.5 +1533.5 MHz
 TX3, 5+5 MHz BW

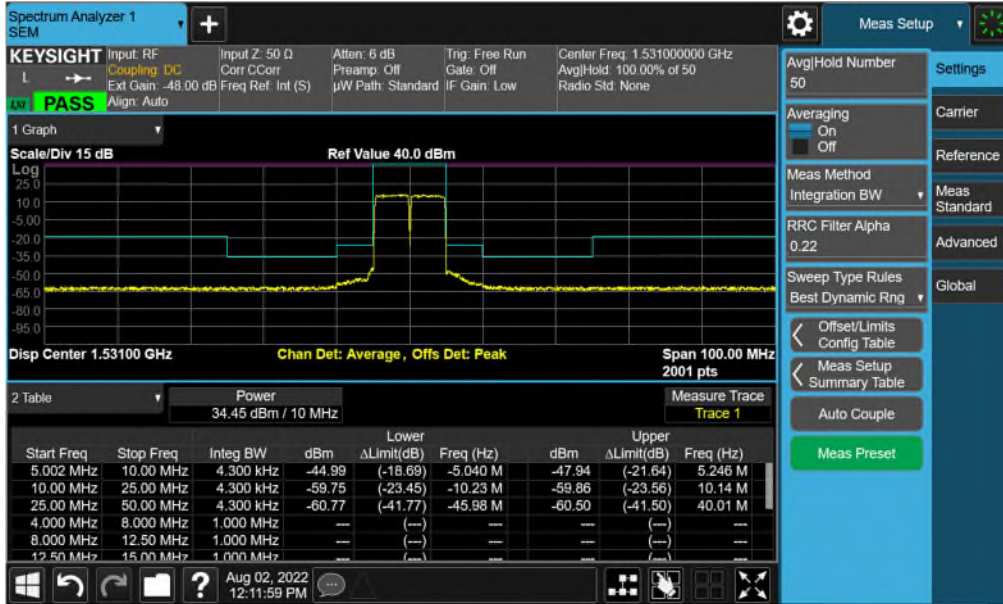

4.2.1.2 FCC 20-48 O&A Emission Compliance

See Section 5.4.1.

4.2.1.3 25.253(b) Emission Compliance

The out-of-band emissions were evaluated for 25.253(b) requirements for the following configurations:

- 1) LTE 5MHz: 64QAM, 1528.5MHz & 256QAM, 1533.5MHz, 30dBm Tx power per port
- 2) LTE 10MHz: 64QAM, 1531MHz, 31dBm Tx power per port
- 3) NR 5MHz: 64QAM, 1528.5MHz & 256QAM, 1533.5MHz, 30dBm Tx power per port
- 4) NR 10MHz: 64QAM, 1531MHz, 31dBm Tx power per port
- 5) 5MHz LTE 1528.5MHz + 5MHz 1533.5MHz NR QPSK/16QAM, 31 dBm Tx power per port.

The out-of-band emissions of the EUT measured for the above configurations met the 25.253(b) requirements.

Only plots with lowest margin for each channel bandwidth are used in this report. The full suite of raw data resides at the MH, New Jersey location.

Edge of Band Emission - 1C 5MHz LTE
 Test Model 3.1a, Modulation 256QAM, 30dBm per Port
 TX1, Channel Frequency 1533.5 MHz

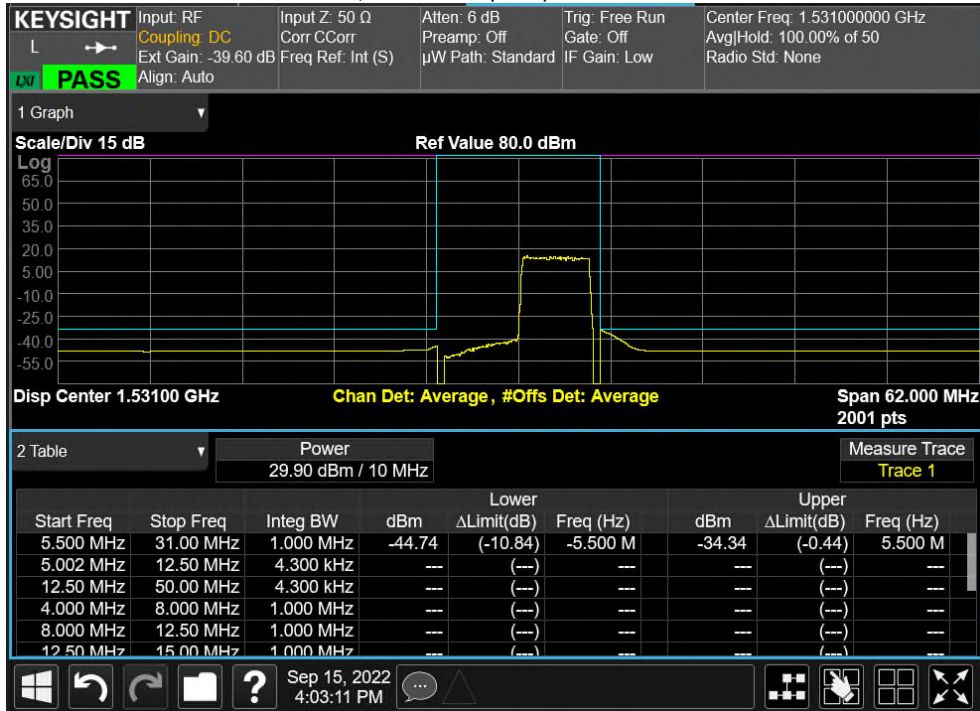

Edge of Band Emission - 1C 10MHz LTE
 Test Model 3.1, Modulation 64QAM, 30dBm per Port
 TX1, Channel Frequency 1531 MHz

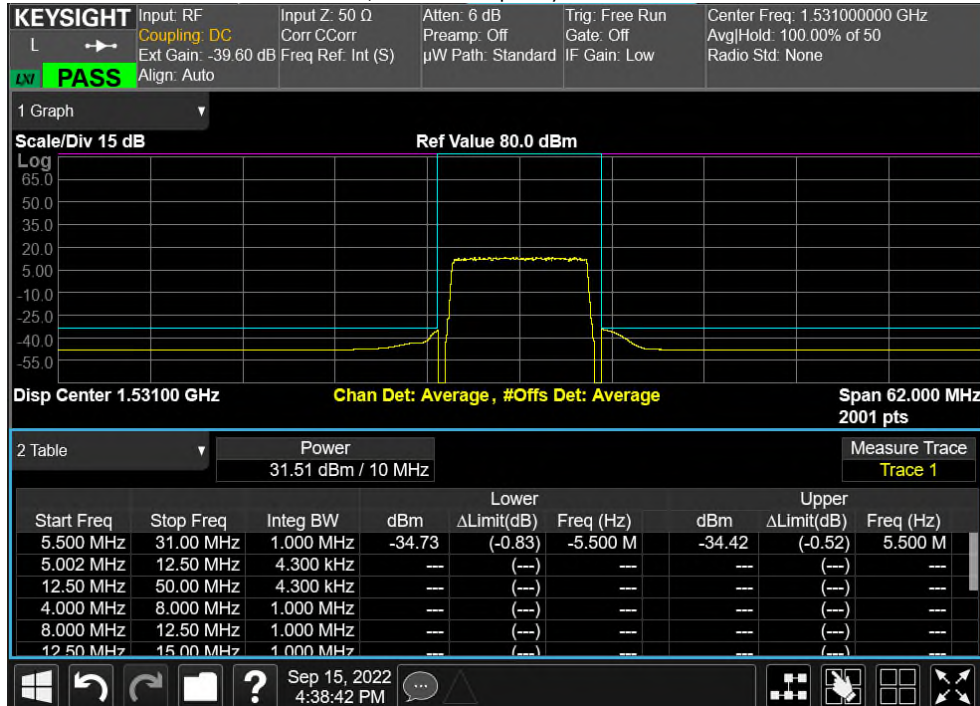

Edge of Band Emission - 2C 5MHz LTE + 5MHz NR
 Test Model 3.2, Modulation QPSK/16QAM, 31dBm per port
 TX1, Channel Frequency 1531 MHz

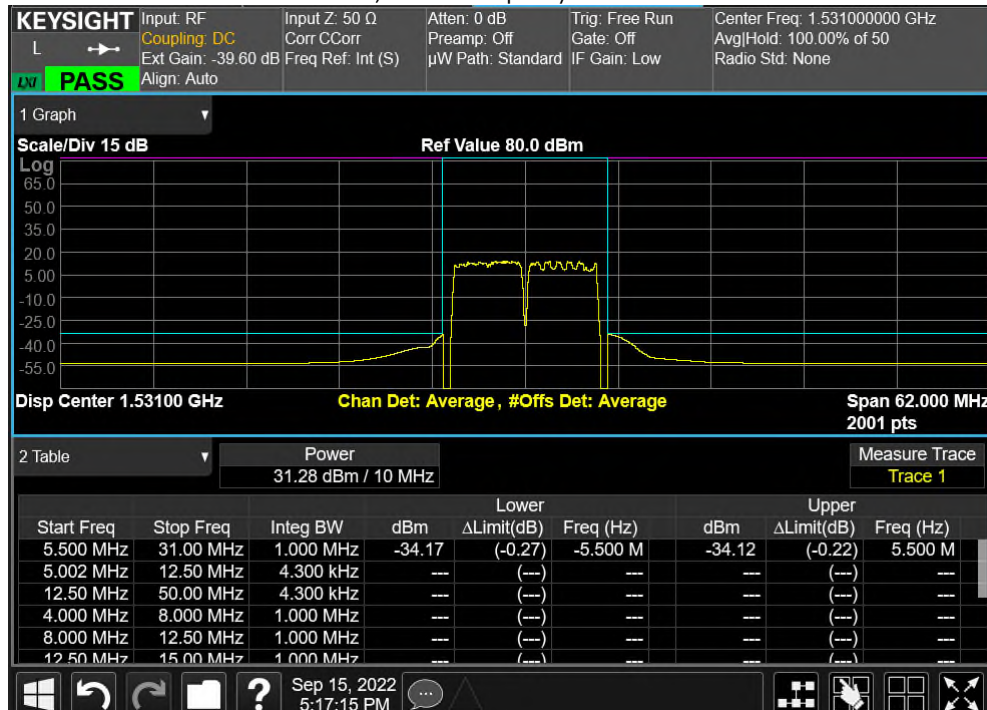

5. FCC Section 2.1051 - Spurious Emissions at Transmit Antenna Port

This test measures the emissions of spurious signals which may come from harmonic, parasitic, intermodulation and frequency conversion products and are outside the necessary bandwidth but excludes Edge-of-Band emissions.

5.1 Section 2.1051 Spurious Emissions at Antenna Terminals

Spurious Emissions at the antenna terminals were investigated per 47CFR Section 2.1057(a)(1) over the frequency range of 10 MHz to 16 GHz which is beyond the 10th harmonic of the carrier frequency. A test coupler which incorporates a low intermod broadband RF attenuator was used to reduce the transceiver’s amplitude to a level usable by the spectrum analyzer. The test configuration is shown in Figure 4.4.1 which documents the test set up used for the measurements. In this set up the complete RF test path was calibrated over the 10 MHz-16 GHz range.

The spurious measurements were made using an MXA Signal Analyzer. These measurements are performed in compliance with ANSI C63.26 and our ISO17025 process. The measurement meets the ANSI C63.26 requirements in paragraphs 5.2.4.4.1 and 5.7 which requires that the number of points in the sweep be > 2 × Span/RBW. The MXA signal analyzer measurements examine the 10 MHz to 16 GHz range.

Measurements were performed for all of the test configurations in Table 5.1 and these matches the test configurations used for Occupied Bandwidth / Edge of Band Emissions, RF Power and modulation.

5.2 Required Limit

The required emission limitation specified in FCC 20-48 O&A Section III H(3) and 47CFR 25.202(f) was applied to these tests.

The emission limits were given in Section 4.2.

5.3 Spurious Emissions at Antenna Terminals Results

Over the required frequency spectrum investigated for the EUT, no reportable out-of-block spurious emissions were detected. The measurement results demonstrate that the subject of the application is in full compliance with the Rules of the Commission.

Table 5.1a: Spurious Emissions at Antenna Terminals

# of Carriers	Test Model	Modulation	TX Port	Channel Frequency MHz	Signal BW MHz	Radio Access Technology	Power dBm	Conducted Spurious Emissions Results
1	3.1	64QAM	1	1528.5	5	LTE	33	Pass
1	3.1a	256QAM	1	1533.5	5	LTE	33	Pass
1	3.1	64QAM	1	1531	10	LTE	33	Pass
1	3.2	QPSK/16QAM	1	1528.5	5	5G-NR	33	Pass
1	3.1a	256QAM	1	1533.5	5	5G-NR	33	Pass
1	3.1	64QAM	1	1531	10	5G-NR	33	Pass
1	3.2	QPSK/16QAM	1	1528.5	5	5G-NR	27.5	Pass
1	3.1a	256QAM	1	1533.5	5	5G-NR	27.5	Pass
1	3.1	64QAM	1	1531	10	5G-NR	27.5	Pass
1	3.1	64QAM	1	1528.5	5	5G-NR	24.5	Pass
1	3.1a	256QAM	1	1533.5	5	5G-NR	24.5	Pass
1	3.1	64QAM	1	1531	10	5G-NR	24.5	Pass
2	1.1	QPSK	1	1528.5+1533.5	5+5	5G-NR+LTE	33	Pass

Table 5.1b: Discrete Spurious Emissions at Antenna Terminals

# of Carriers	Test Model	Modulation	TX Port	Channel Frequency MHz	Signal BW MHz	Radio Access Technology	Power dBm	Discrete Conducted Spurious Emissions Results
1	3.1	64QAM	1	1528.5	5	LTE	33	Pass
1	3.1a	256QAM	1	1533.5	5	LTE	33	Pass
1	3.1	64QAM	1	1531	10	LTE	33	Pass
1	3.2	QPSK/16QAM	1	1528.5	5	5G-NR	33	Pass
1	3.1a	256QAM	1	1533.5	5	5G-NR	33	Pass
1	3.1	64QAM	1	1531	10	5G-NR	33	Pass
2	1.1	QPSK	1	1528.5+1533.5	5+5	5G-NR+LTE	33	Pass

5.4 Spurious Emissions Plots

NOTE: Only plots with lowest margin in each frequency range are used in this report. The full suite of raw data resides at the MH, New Jersey location.

5.4.1 FCC 20-48 O&A Emission (1541-1650MHz) Compliance

The spurious emissions in the frequency range of 1541-1650MHz were evaluated first at the antenna port with 33dBm power per port for LTE and NR 5MHz, 10MHz and 5MHz LTE + 5MHz NR carriers. All the limits in the plot are conducted limits per port by assuming 0dBi antenna gain. The maximum allowed antenna gain is 16dBi. *If the minimum margin is larger than 16dB, the spurious emissions of the EUT in this frequency range meet the requirements for any transmit power.* For the frequency ranges where the minimum margins are less than 16dB due to high noise floor, the spurious emissions are to be reevaluated at a lower transmit power. For 16 dBi antenna gain, the maximum allowed transmit power is 17.8 dBm per port. If the spurious emissions meet the requirements with the transmit power at 17.8dBm per port or higher, the EUT is in compliance with the FCC 20-48 O&A emission requirements.

At 33dBm output power per port, the antenna gain plus path loss needs to be less than 0.78dB with 39.8 dBm EIRP power limit and 4MIMO. Therefore, the minimum margin for 33 dBm per port and 4MIMO needs to be at least 0.78dB. The emissions in the frequency range of 1610-1650MHz have more than 24dB margin. Hence, the emissions in 1541-1559MHz and 1559-1610MHz were reevaluated at 24.5dBm power per port.

Power Setting per Port (Tx1)	Freq Range (MHz)	Margin (Measured)		Conducted Limit Per Port with 0 dBi Ant Gain	Min Margin Required (dB)	Compliance
		dB	RBW			
33dBm	1541 -1559	9.1	1MHz	-61dBm/MHz	0.78	Y
	1559-1610	8.0	1MHz	-76dBm/MHz		Y
	1610 -1650	24.2	1MHz	-61dBm/MHz		Y
	1541 -1559	6.8	2kHz	-88dBm/2kHz		Y
	1559-1610	17.0	750Hz	-86dBm/700Hz		Y
	1610 -1650	31.12	2kHz	-71dBm/700Hz		Y

Note: the following configurations were evaluated for the above frequency ranges: 1) LTE 5MHz: 64QAM, 1528.5MHz & 256QAM, 1533.5MHz, 2) LTE 10MHz: 64QAM, 1531MHz, 3) NR 5MHz: 64QAM, 1528.5MHz & 256QAM, 1533.5MHz, 4) NR 10MHz: 64QAM, 1531MHz, 5) 5MHz LTE 1528.5MHz + 5MHz 1533.5MHz NR 256QAM.

With the EUT power at 24.5dBm per port, the antenna gain plus path loss needs to be less than 9.3dB with 39.8 dBm EIRP power limit and 4MIMO. Therefore, the minimum margin for 24.5 dBm power per port and 4MIMO needs to be at least 9.3dB.

Power Setting per Port	Freq Range (MHz)	Margin (Measured)		Conducted Limit Per Port with 0 dBi Ant Gain	Min Margin Required (dB)	Compliance
		dB	RBW			
24.5dBm	1541 -1559	24.81	1MHz	-61dBm/MHz	9.3	Y
	1559-1610	21.81	1MHz	-76dBm/MHz		Y
	1541 -1559	17.99	2kHz	-88dBm/2kHz		Y

Note: the following configurations were evaluated for the above frequency ranges: 1) LTE 5MHz: 256QAM, 1533.5MHz, 2) NR 5MHz: 64QAM, 1528.5MHz, 3) NR 10MHz: 64QAM, 1531MHz, 4) 5MHz LTE 1528.5MHz + 5MHz 1533.5MHz NR 256QAM.

The minimum margin is 17.99dB with the EUT transmitting at 24.5dBm per port. As a result, the spurious emissions of the EUT transmitting at 24.5dBm per port or lower met the FCC 20-48 O&A spurious and discrete spurious emissions requirements.

5.4.1.1 Spurious Emissions with 1MHz RBW

# of Carriers	Test Model	Modulation	TX Port	Channel Frequency MHz	Signal BW MHz	Radio Access Technology	Power dBm
1	3.1	64QAM	1	1531	10	LTE	33

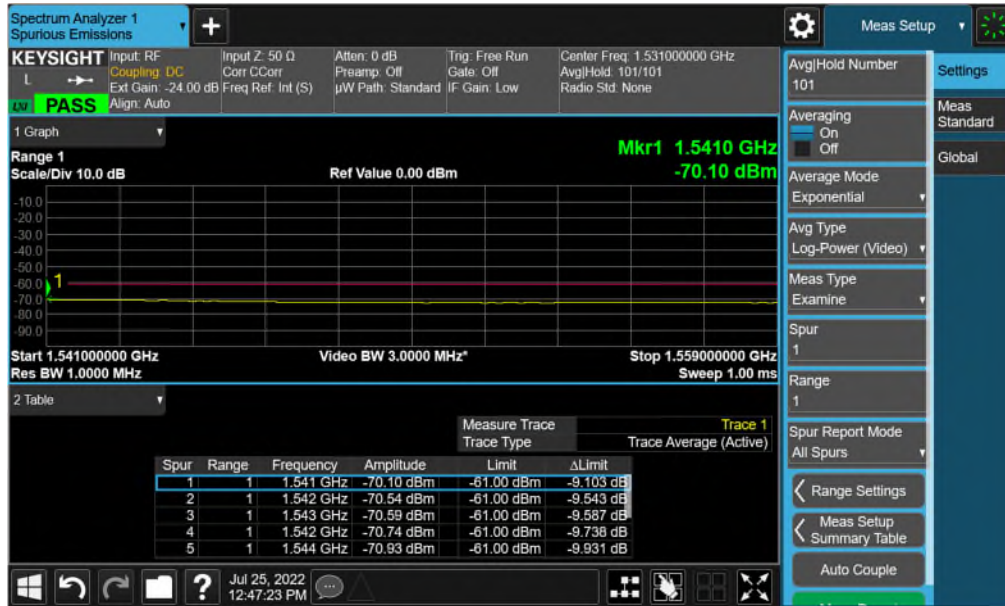

1.559GHz – 1.61GHz

# of Carriers	Test Model	Modulation	TX Port	Channel Frequency MHz	Signal BW MHz	Radio Access Technology	Power dBm
1	3.2	QPSK/16QAM	1	1528.5	5	5G-NR	33

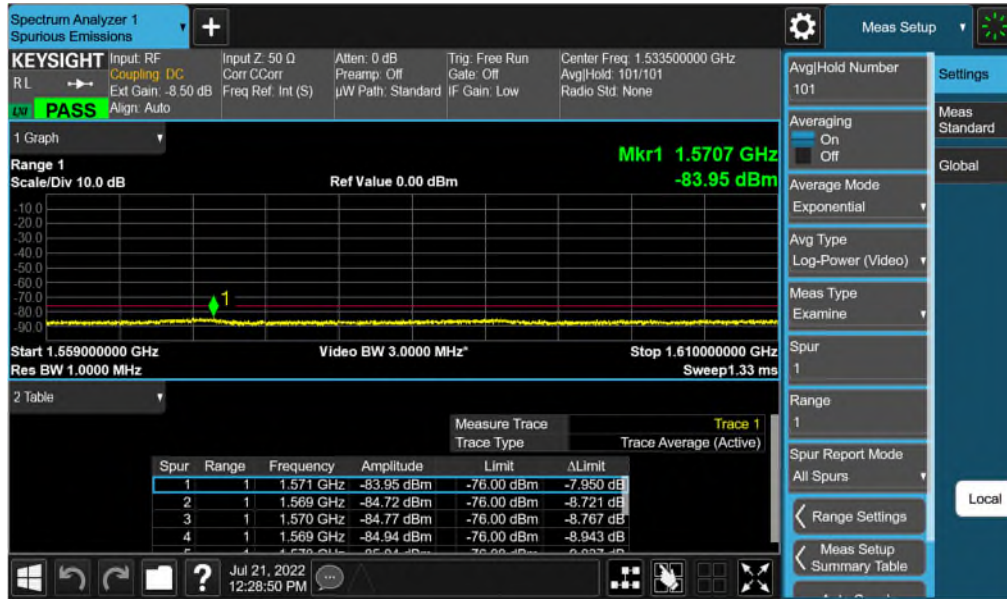

1.61GHz – 1.65GHz

# of Carriers	Test Model	Modulation	TX Port	Channel Frequency MHz	Signal BW MHz	Radio Access Technology	Power dBm
1	3.1a	256QAM	1	1533.5	5	5G-NR	33

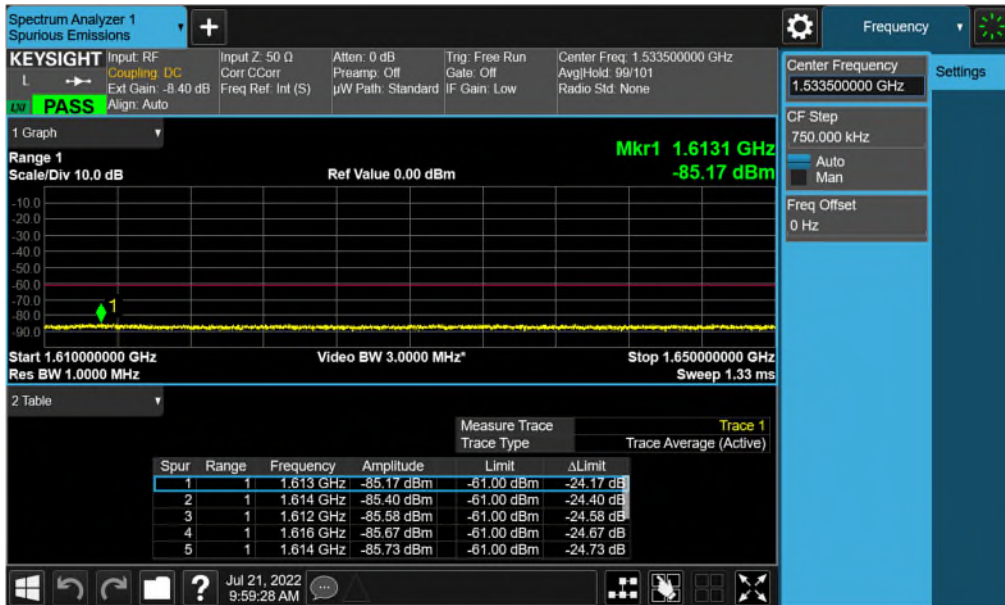

1.541GHz – 1.559GHz

# of Carriers	Test Model	Modulation	TX Port	Channel Frequency MHz	Signal BW MHz	Radio Access Technology	Power dBm
2	3.1a	256QAM	1	1528.5+1533.5	5+5	LTE+NR	24.5



1.559GHz – 1.610GHz

# of Carriers	Test Model	Modulation	TX Port	Channel Frequency MHz	Signal BW MHz	Radio Access Technology	Power dBm
1	3.1	64QAM	1	1531	10	LTE	24.5

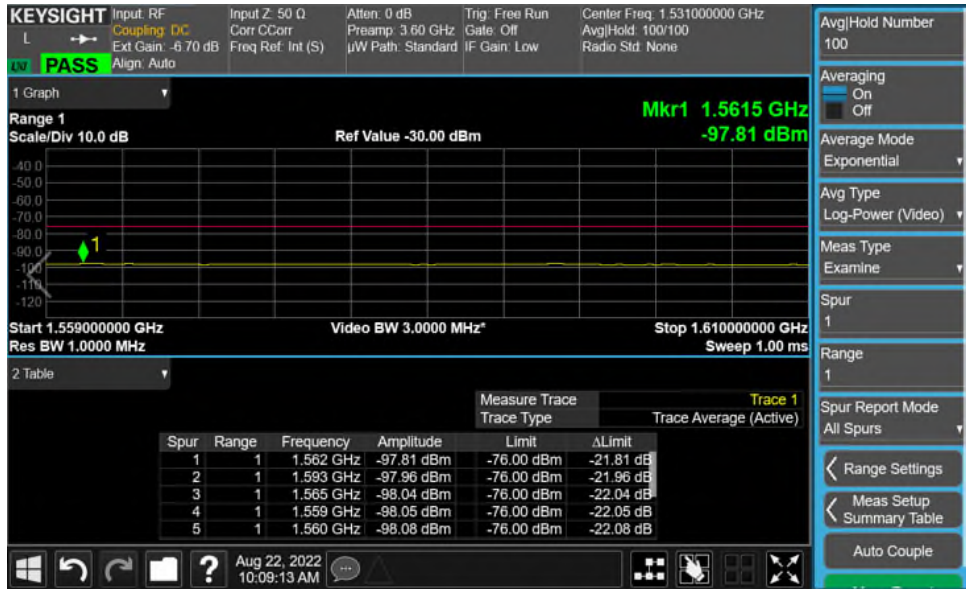

5.4.1.2 Discrete Spurious Emissions Plots

1.541 GHz – 1.559 GHz

# of Carriers	Test Model	Modulation	TX Port	Channel Frequency MHz	Signal BW MHz	Radio Access Technology	Power dBm
1	3.1a	256QAM	1	1533.5	5	LTE	33

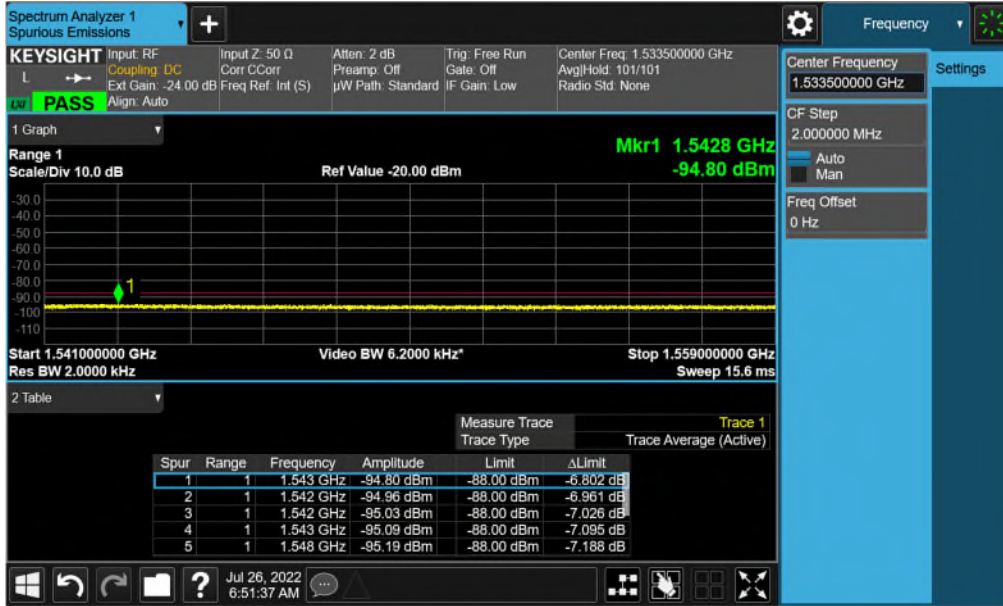

1.559 GHz – 1.610 GHz

# of Carriers	Test Model	Modulation	TX Port	Channel Frequency MHz	Signal BW MHz	Radio Access Technology	Power dBm
1	3.1a	256QAM	1	1533.5	5	LTE	33

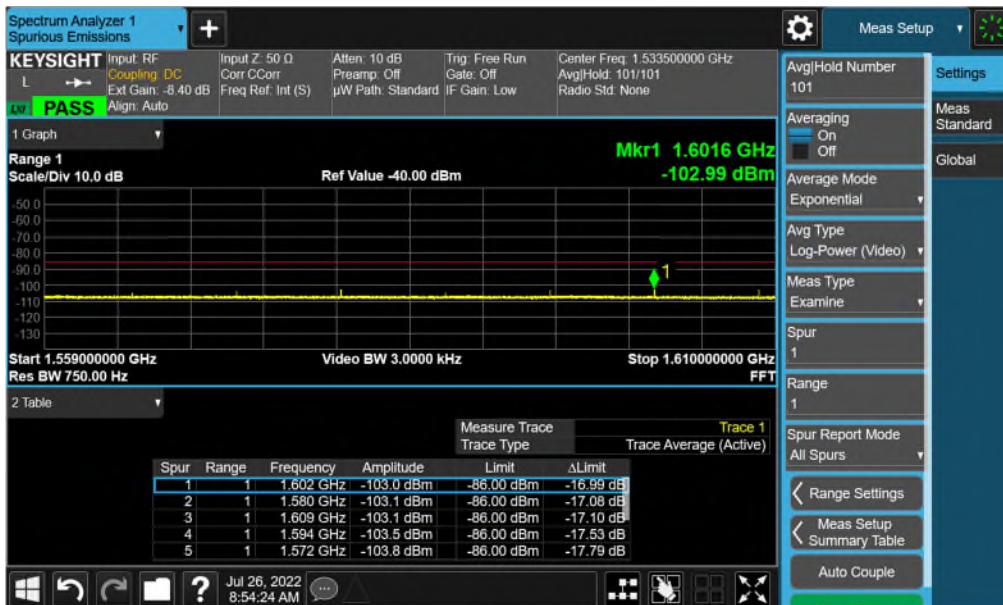

1.610 GHz – 1.650 GHz

# of Carriers	Test Model	Modulation	TX Port	Channel Frequency MHz	Signal BW MHz	Radio Access Technology	Power dBm
1	3.1a	256QAM	1	1533.5	5	LTE	33

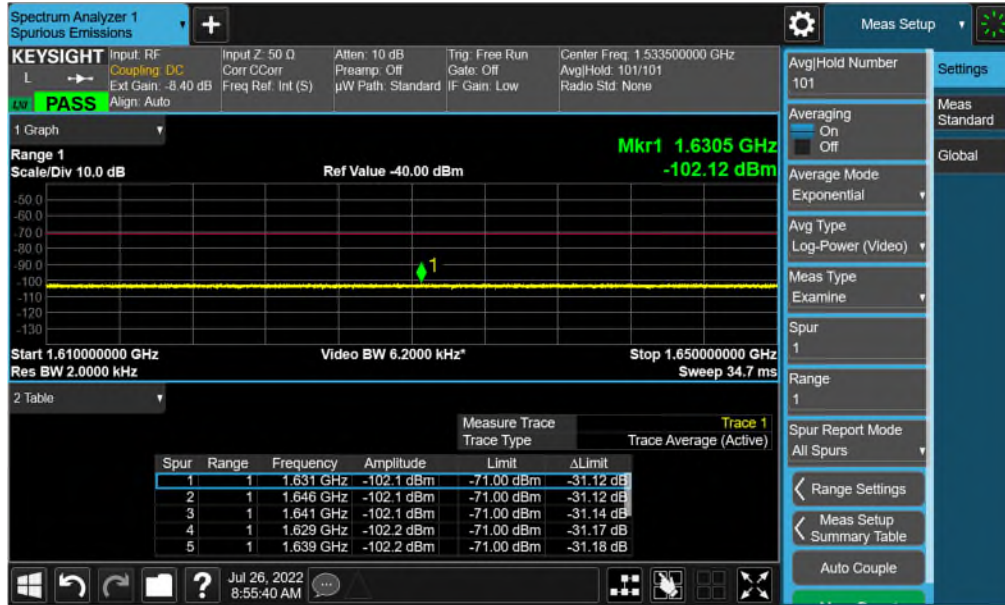

1.541GHz – 1.559GHz

# of Carriers	Test Model	Modulation	TX Port	Channel Frequency MHz	Signal BW MHz	Radio Access Technology	Power dBm
1	3.1	64QAM	1	1531	10	LTE	24.5

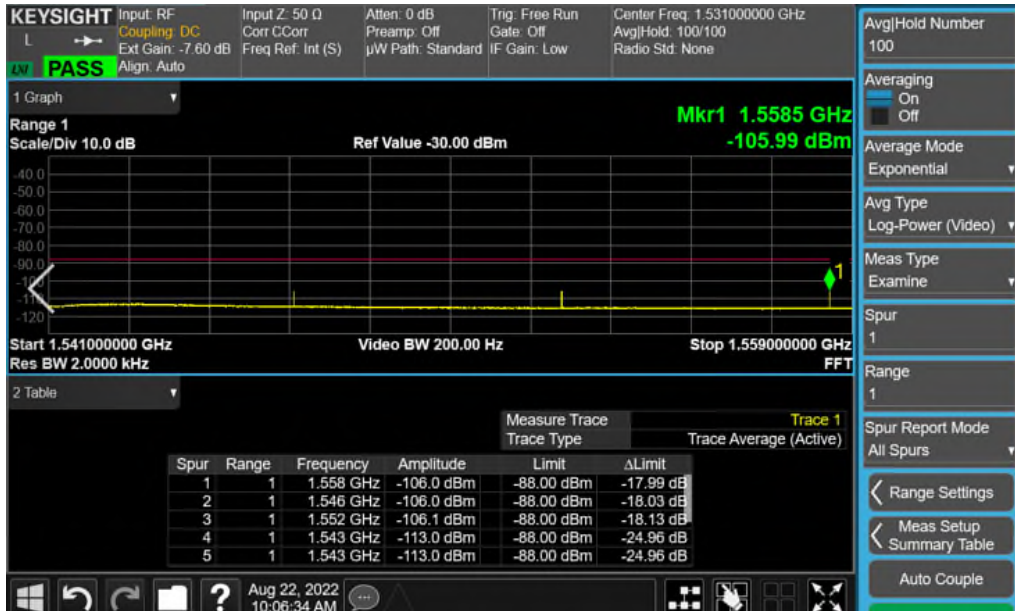

5.4.2 25.202(f) Emission (9kHz – 16GHz) Compliance

The unwanted emissions near the band edges were provided in Section 4.2. The unwanted emissions between 1541-1650MHz were provided in Section 5.4.1 where the limits there are much tighter than that of 25.202(f).

The emissions below 1.48GHz have more than 20dB margins and their plots were presented here for information only.

# of Carriers	Test Model	Modulation	TX Port	Channel Frequency MHz	Signal BW MHz	Radio Access Technology	Power dBm
1	3.1a	256QAM	1	1533.5	5	5G-NR	27.5

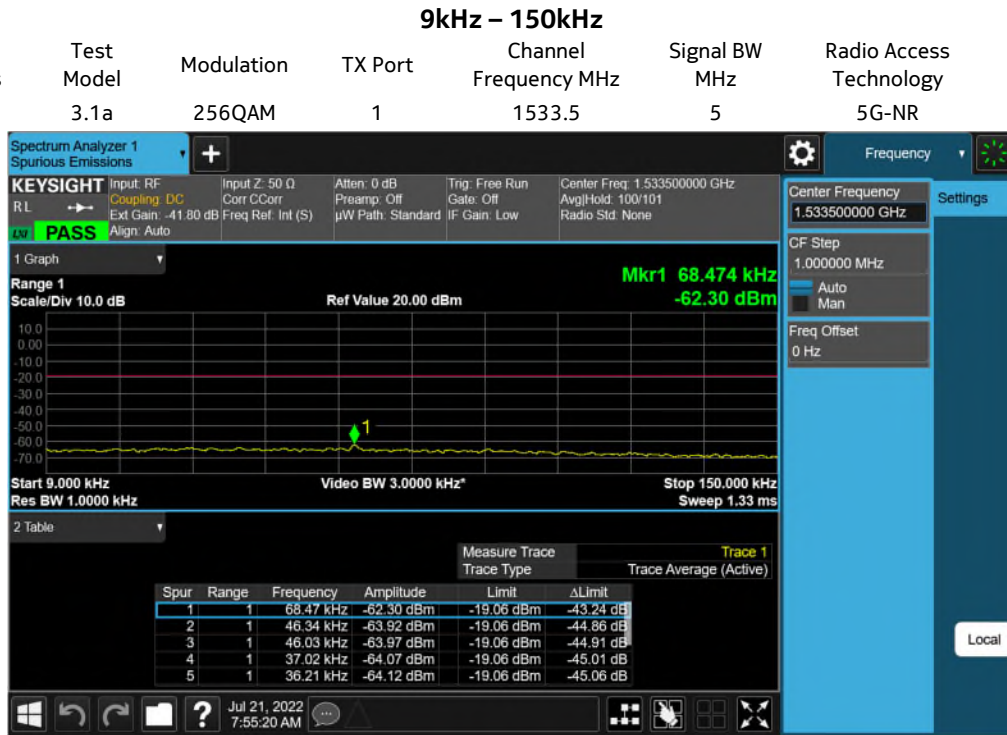

# of Carriers	Test Model	Modulation	TX Port	Channel Frequency MHz	Signal BW MHz	Radio Access Technology	Power dBm
2	1.1	QPSK	1	1528.5+1533.5	5+5	5G-NR+LTE	33

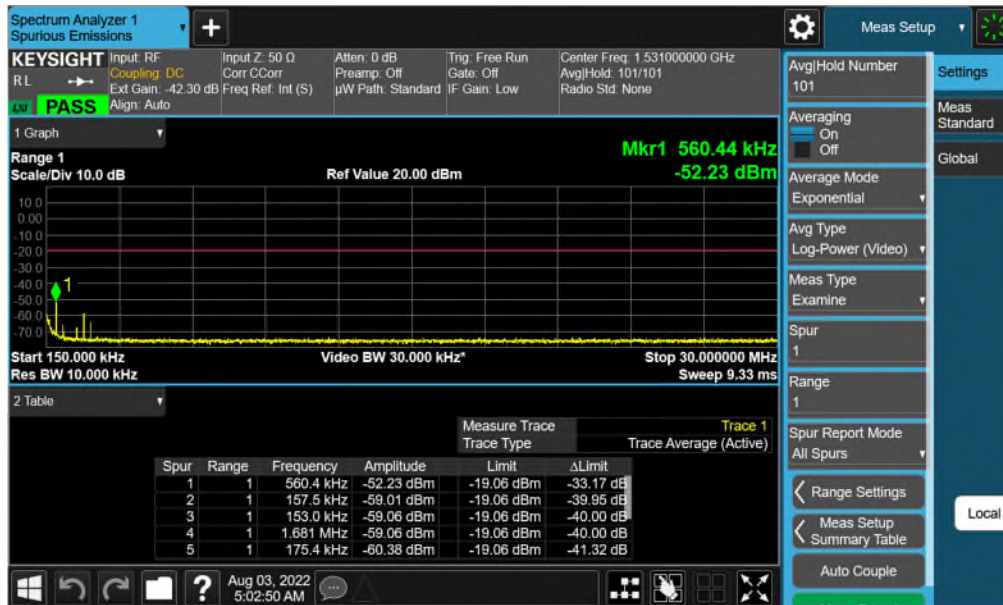

# of Carriers	Test Model	Modulation	TX Port	Channel Frequency MHz	Signal BW MHz	Radio Access Technology	Power dBm
1	3.1a	256QAM	1	1533.5	5	LTE	33

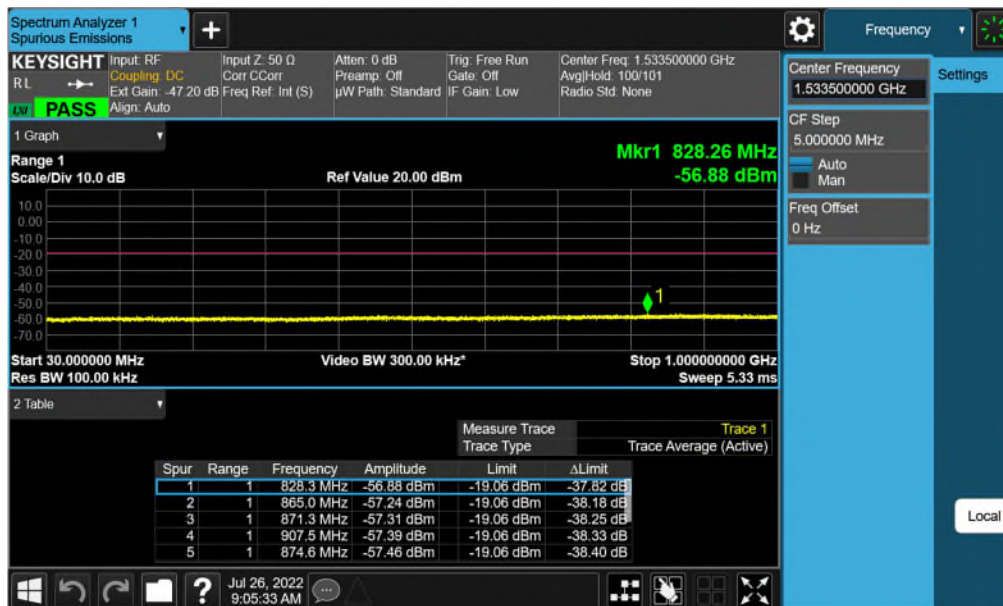

1GHz – 1.48GHz

# of Carriers	Test Model	Modulation	TX Port	Channel Frequency MHz	Signal BW MHz	Radio Access Technology	Power dBm
1	3.1	64QAM	1	1531	10	5G-NR	24.5

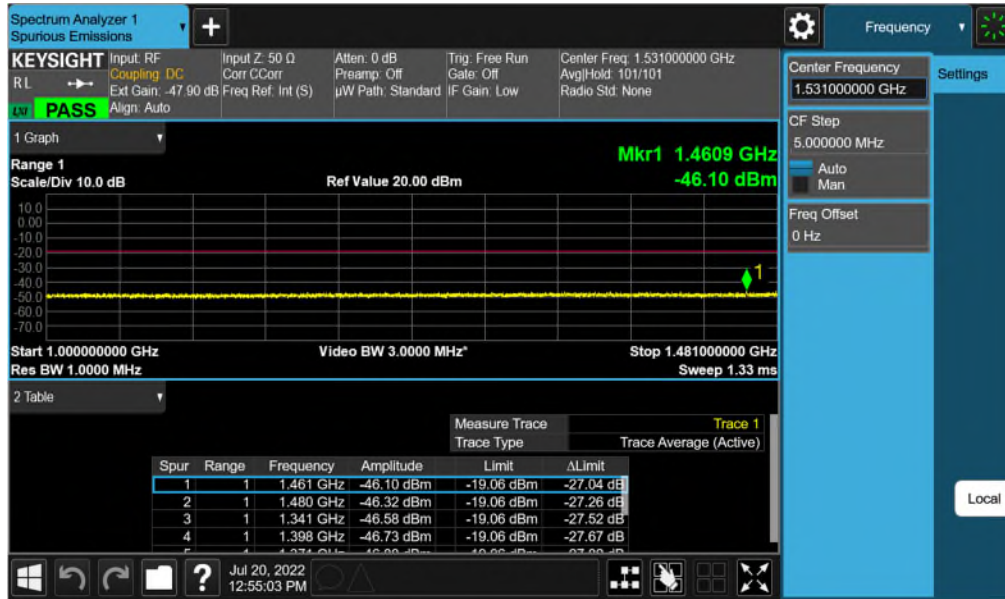

1.581GHz – 10GHz

# of Carriers	Test Model	Modulation	TX Port	Channel Frequency MHz	Signal BW MHz	Radio Access Technology	Power dBm
1	3.1	64QAM	1	1531	10	5G-NR	33

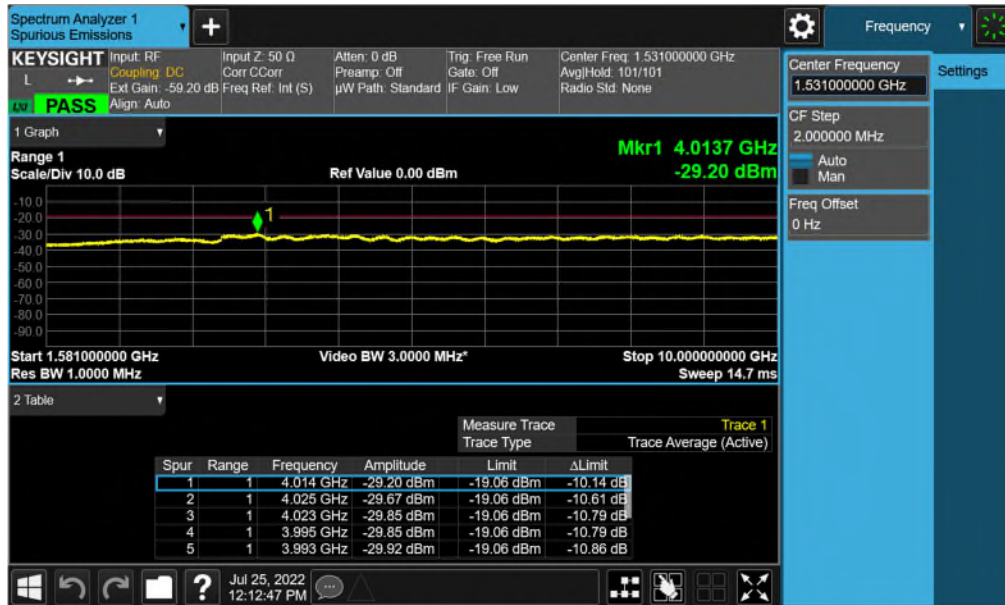

10GHz – 16GHz

# of Carriers	Test Model	Modulation	TX Port	Channel Frequency MHz	Signal BW MHz	Radio Access Technology	Power dBm
2	1.1	QPSK	1	1528.5+1533.5	5+5	5G-NR+LTE	33

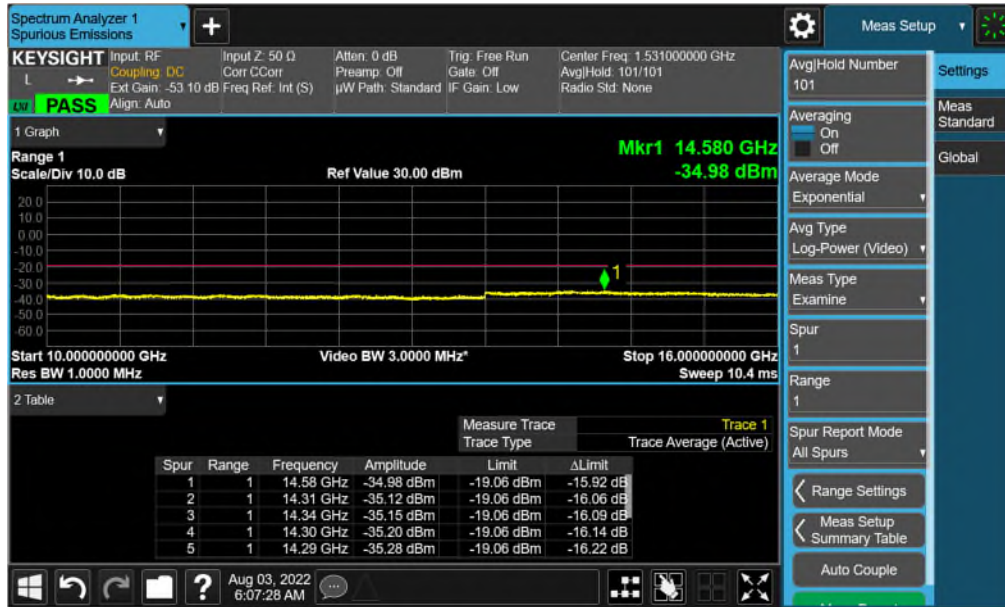

5.4.3 25.253(b) Emissions (9kHz – 16GHz) Compliance

The emission limit of 25.253(b) is -27.9dBm/MHz total or -33.9dBm/MHz per port. The spurious emission limit of 25.202(f) is -13dBm/4kHz total or -19dBm/4kHz per port which is equal to 5dBm/MHz per port. The difference between 25.202(f) and 25.253(b) spurious limits is 38.9dB

The FCC 20-48 O&A requirements in the frequency range of 1541-1650MHz are more stringent than that of 25.253(b). Therefore, the emissions in the frequency range of 1541-1650MHz are complied with 25.253(b) requirements and no additional tests are needed in this frequency range.

The spurious emissions have been evaluated for 25.202(f) requirements with a Tx power of 33dBm per port for the following configurations:

- 1) LTE 5MHz: 64QAM, 1528.5MHz & 256QAM, 1533.5MHz,
- 2) LTE 10MHz: 64QAM, 1531MHz,
- 3) NR 5MHz: 64QAM, 1528.5MHz & 256QAM, 1533.5MHz,
- 4) NR 10MHz: 64QAM, 1531MHz,
- 5) 5MHz LTE 1528.5MHz + 5MHz 1533.5MHz NR 256QAM.

The minimum margins from the above tests for 25.202(f) met the requirements of 25.253(b) in the frequency ranges of 30M-1GHz and 10-16GHz with 33dBm Tx power per port, where the worst emission in the frequency range of 30MHz-1GHz was -56.88dBm/100kHz which is equal to -46.88dBm/MHz (12.98 dB above 25.253(b) limit) and the worst emission in the frequency range of 10GHz-16GHz was -34.98dBm/MHz (1.08 dB above 25.253(b) limit). Therefore, the emissions in the frequency range of 30-1GHz MHz and 10-16GHz were not reevaluated for 25.253(b).

The worst emission from the above tests for 25.202(f) in the frequency range of 9kHz-30MHz is only 1.78dB above the 25.253(b) requirement due to high noise floor in the test setup. Therefore, only two configurations, 5MHz LTE carrier at 1533.5MHz and 5MHz LTE+5MHz NR, were reevaluated in 9kHz-30MHz.

The spurious emissions were evaluated for 25.253(b) requirements for the following configurations in the frequency range of 1-1.5GHz:

- 1) LTE 5MHz: 64QAM, 1528.5MHz & 256QAM, 1533.5MHz, 30dBm Tx power per port
- 2) LTE 10MHz: 64QAM, 1531MHz, 31dBm Tx power per port
- 3) NR 5MHz: 64QAM, 1528.5MHz, 30dBm Tx power per port
- 4) NR 10MHz: 64QAM, 1531MHz, 31dBm Tx power per port
- 5) 5MHz LTE 1528.5MHz + 5MHz 1533.5MHz NR 256QAM, 31 dBm Tx power per port.

The spurious emissions were evaluated for 25.253(b) requirements for the following configurations in the frequency range of 1.65GHz-10GHz:

- 1) LTE 5MHz: 64QAM, 1528.5MHz & 256QAM, 1533.5MHz, 30dBm per port
- 3) NR 5MHz: 64QAM, 1528.5MHz & 256QAM, 1533.5MHz, 30dBm per port
- 4) NR 10MHz: 64QAM, 1531MHz, 31dBm per port
- 5) 5MHz LTE 1528.5MHz + 5MHz 1533.5MHz NR 256QAM, 31 dBm per port.

The spurious emissions of the EUT measured for the above configurations met the 25.253(b) requirements. Only plots with lowest margin in each frequency range are used in this report. The full suite of raw data resides at the MH, New Jersey location. The plots in the frequency range of 30G-1GHz and 10G-16GHz were given in Section 5.4.2.

9kHz – 150kHz

# of Carriers	Test Model	Modulation	TX Port	Channel Frequency MHz	Signal BW MHz	Radio Access Technology	Power dBm
2	3.2	QPSK	1	1528+1533.5	5+5	LTE + 5G-NR	33.5

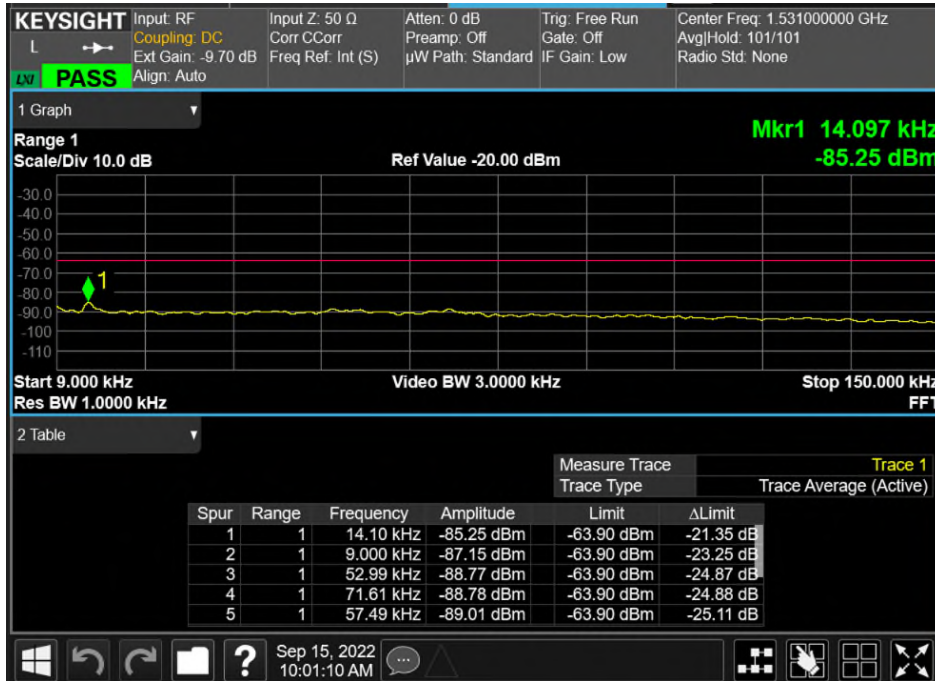

150kHz – 30MHz

# of Carriers	Test Model	Modulation	TX Port	Channel Frequency MHz	Signal BW MHz	Radio Access Technology	Power dBm
2	3.2	QPSK	1	1528+1533.5	5+5	LTE + 5G-NR	33.5

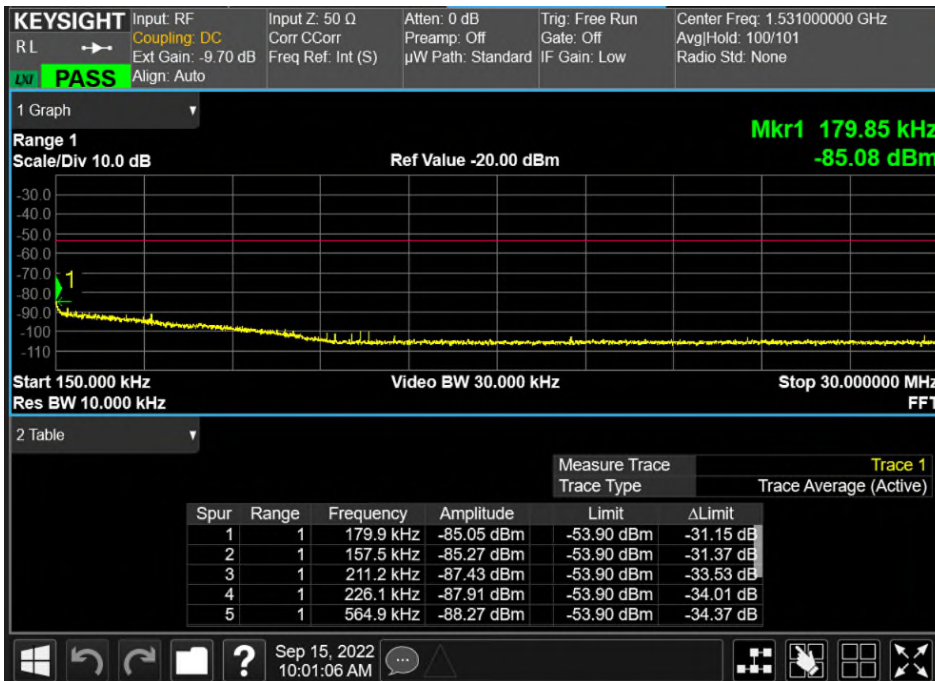

1GHz – 1.5GHz

# of Carriers	Test Model	Modulation	TX Port	Channel Frequency MHz	Signal BW MHz	Radio Access Technology	Power dBm
2	3.1a	256QAM	1	1528+1533.5	5+5	LTE + 5G-NR	31.3

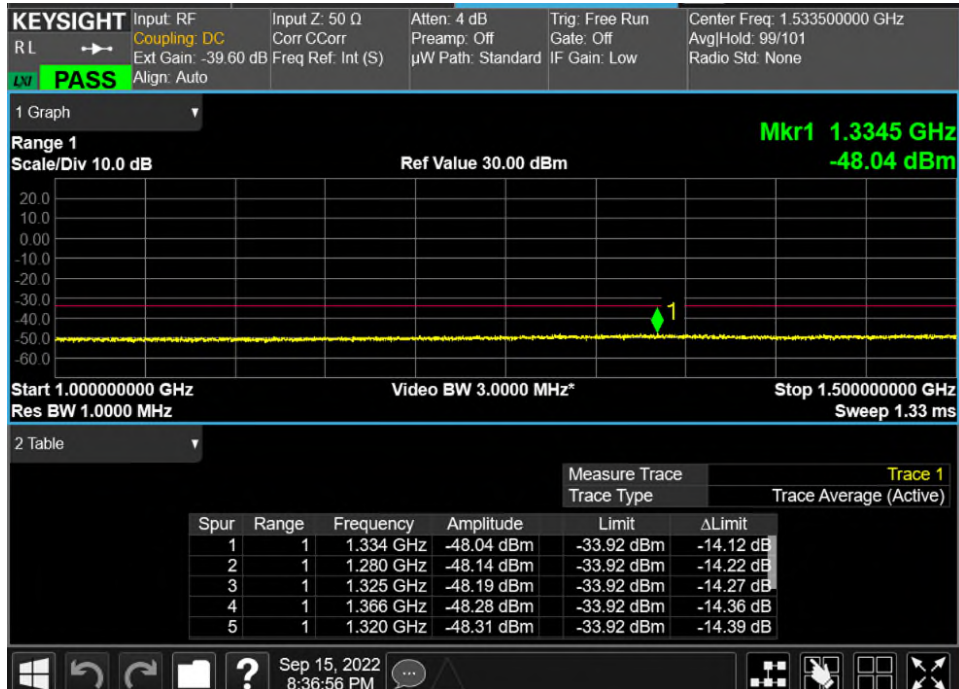

165GHz – 10GHz

# of Carriers	Test Model	Modulation	TX Port	Channel Frequency MHz	Signal BW MHz	Radio Access Technology	Power dBm
2	3.1a	256QAM	1	1528+1533.5	5+5	LTE + 5G-NR	31.3

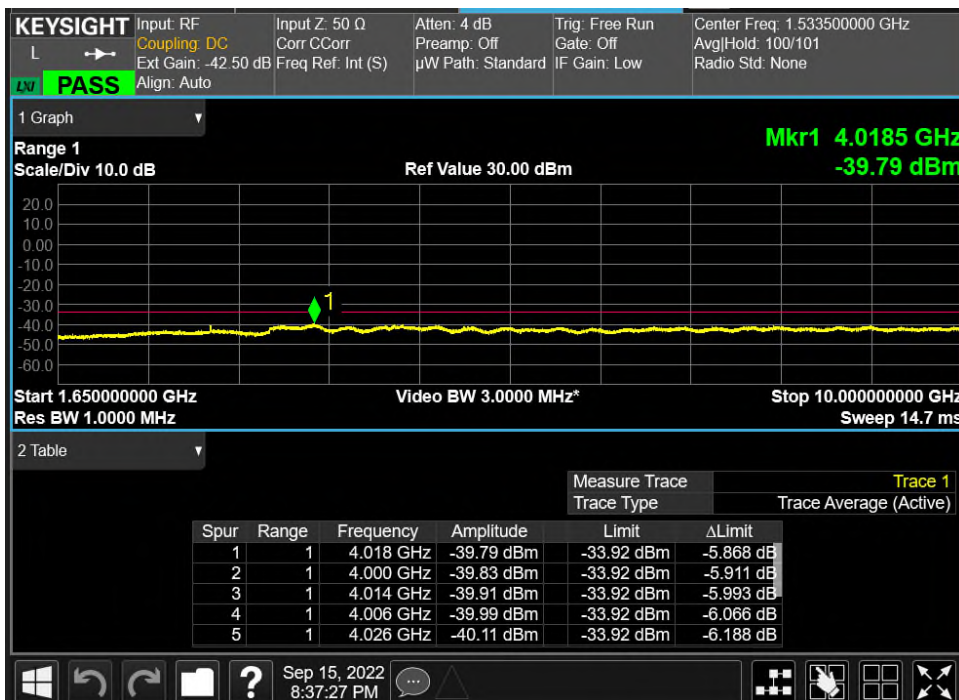

6. Section 2.1053 - Measurement Required: Field Strength of Spurious Radiation

The field strength measurements of radiated spurious emissions were made in a FCC registered 3-meter semi-anechoic chamber AR-5, (FCC Registration Number: 395774) NVLAP Lab Code: 100275-0 and IC (Filing Number: 6933F-5) which is maintained by Nokia Bell Labs in Murray Hill, New Jersey.

6.1 Spurious Radiation and Radiated Emissions Requirements.

This product meets Parts 2,15 and 25 requirements. FCC Part 15 Class B require emissions to be below 54.5 dBuV/m at 3m.

47CFR 25.202(f) specified that the mean power limit for the spurious emissions which are two bandwidths away from the channel edges is -13dBm/4kHz. 47CFR 25.253(b) specified that the mean power limit for the out-of-channel emissions is -27.9dBm/MHz.

The requirements for the levels of spurious radiation as a function of the level of the unmodulated carrier is calculated as the field produced by an ideal dipole excited by the transmitter output power according to the following relation taken from Reference Data for Radio Engineers, page 676, 4th edition, IT&T Corp.

$$E = [(30 * EIRP)^{1/2}] / R,$$

$$E \text{ (dB}\mu\text{V/m)} = \text{EIRP (dBm)} - 20 \log d \text{ (m)} + 104.77,$$

where:

E = Field Intensity in Volts/meter

EIRP = Transmitted Power in Watts

R = Measurement distance in meters

At 3m and -13dBm/4kHz EIRP,

$$E = 82.23 \text{ dB}\mu\text{V/m/4kHz} = 106.2 \text{ dB}\mu\text{V/m/MHz}.$$

At 3m and -27.9dBm/MHz EIRP,

$$E = 67.3 \text{ dB}\mu\text{V/m/MHz} = 57.3 \text{ dBm/100kHz}.$$

The non-report level is 47.3 dB μ V/m/MHz or 37.3 dB μ V/m/100kHz. The FCC Part 15 Class B limit is 54 dB μ V/m above 1GHz. The worst peak-to-average ratio is 8.38dB at 0.1%. The FCC Part 15 Class B requirement is more stringent.

The field strength of radiated spurious emissions measured was determined by

$$E \text{ (dB}\mu\text{V/m)} = V_{\text{meas}} \text{ (dB}\mu\text{V)} + \text{Cable Loss (dB)} + \text{Antenna Factor (dBi/m)}.$$

Field strength measurements of radiated spurious emissions were made in the 3m semi-anechoic chamber, AR-5 as detailed above. The recommendations of ANSI C63.4 and ANSI C63.26 were followed for EUT testing setup, cabling, and measurement approach and procedures. All the measurement equipment used, including antennas, was calibrated in accordance with ISO 9001 process. The EUT setup diagram is given in section 6.2.

The spectrum from 30MHz to 16GHz, the tenth harmonic of the carrier, was searched for spurious radiation. Measurements were made using both horizontally and vertically polarized broadband antennas. Per FCC regulations, the comparison of the emissions directly to the limit is appropriately made using the substitution

method. However, both FCC and ANSI C63.26 accept using the field strength radiated measurement for limits specified in power without requiring substitution method for a licensed Tx.

6.2 Field Strength of Spurious Radiation Results:

This product meets Part 25 Requirements. For the Title 47CFR section 25.202(f) and 2.1053 test, the field strength of any spurious radiation, measured at 3m, is required to be less than 82.2dB μ V/m/4kHz or 58.2 dB μ V/m/MHz. Emissions equal to or less than 38.23 dB μ V/m/MHz are not reportable and may be verified using field strength measurements with broadband antennas.

Over the out of band spectrum investigated from 30 MHz to beyond the tenth harmonic of the carrier (16GHz), no reportable spurious emissions were detected. Additionally, from 30 MHz to beyond the tenth harmonic of the carrier (16GHz), all non-transmit carrier emissions were below 54.5 dB μ V/m. This demonstrates that the AWHKB 5G AirScale Micro RRH 4T4R B24, complies with FCC Part 15 Class B, and FCC Sections 2.1053, 25.202(f) and 2.1057 of the Rules.

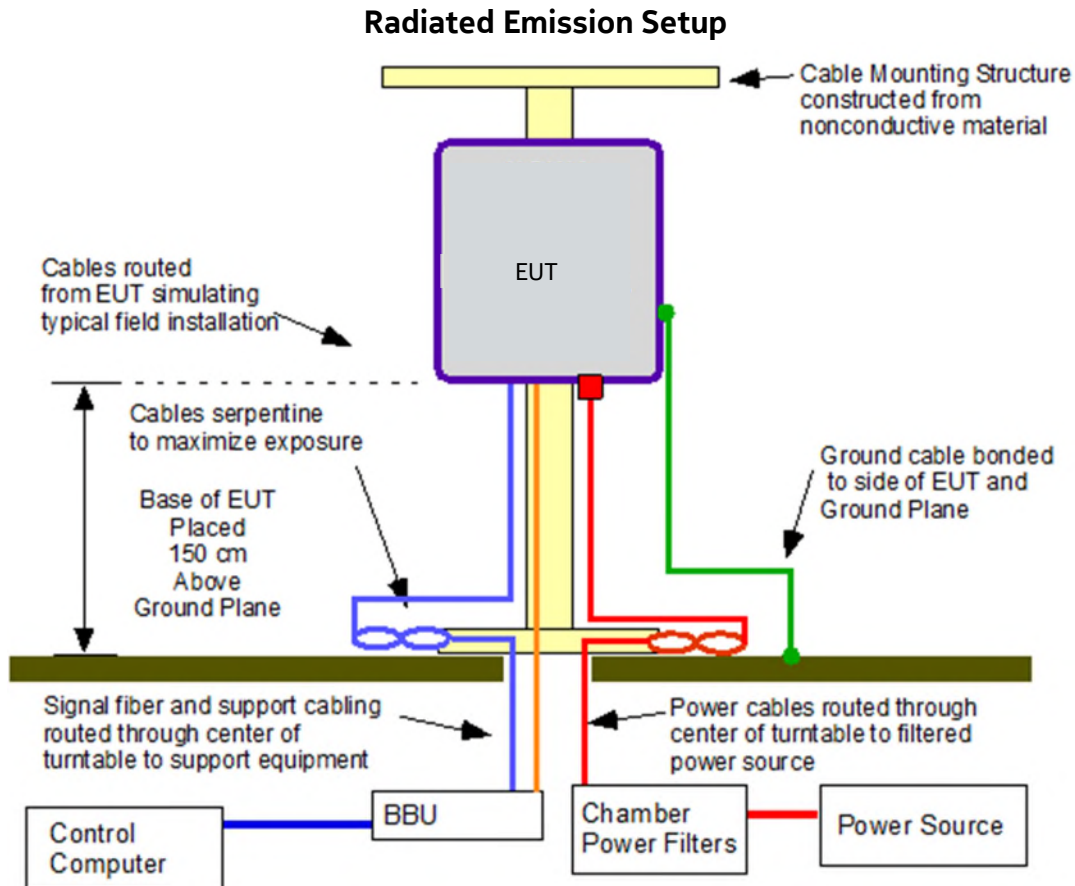

6.2.1 Transmitter Measurements of Radiated Spurious Emissions Plots

RE 30MHz – 1GHz

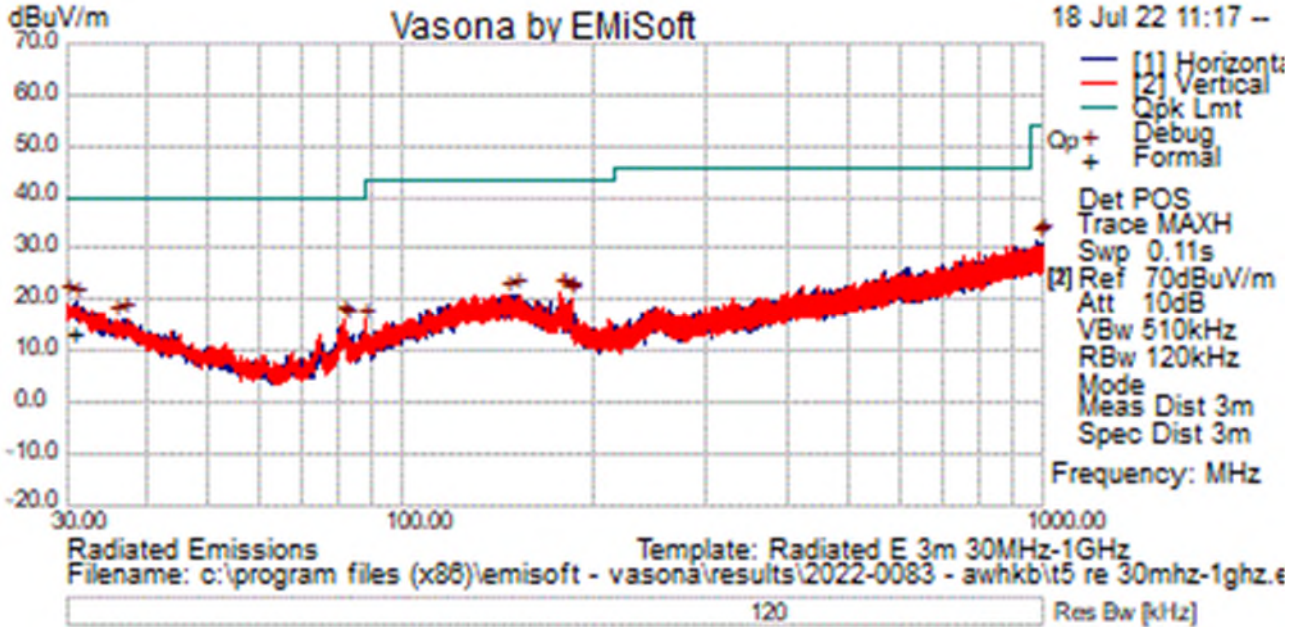

Test Information

Results Title	Radiated E 3m 30MHz-1GHz
File Name	t5b re 30mhz-1ghz.emi
Test Laboratory	MH-AR6; 48%RH, 24C, 1001hPa.
Test Engineer	GM
Test Software	Vasona by EMiSoft, version 6.061
Equipment	Nokia
EUT Details	2022-0083 - AWHKB, 1531MHz, ETM1.1, 10MHZ BW, 33dBm
Configuration	FCC Pt.15-B/ICES/GR1089, RE 30MHz-1GHz FCC B 3 meter distance. 0dB Int Attn, RBW: 120KHz, VBW: 300KHz. MXE E1218, PA E507, Bilog EI43, RF cables AR6 1-1a
Date	2022-07-19 09:23:31

Formal Data

Freq. (MHz)	Raw (dBuV)	Cable (dB)	Factor (dB)	Level (dBuV/m)	Emission Type	Pol (H/V)	Ht (cm)	Az (deg)	Limit (dBuV/m)	Margin (dB)	Pass/Fail	Comments
30.512	22.50	0.69	-9.61	13.58	QuasiMax	H	196	308	40.00	-26.42	Pass	

Preview Data

Freq. (MHz)	Raw (dBuV)	Cable (dB)	Factor (dB)	Level (dBuV/m)	Emission Type	Pol (H/V)	Ht (cm)	Az (deg)	Limit (dBuV/m)	Margin (dB)	Pass/Fail	Comments
30.064667	29.14	0.69	-9.36	20.47	Debug	H	100	315	40.00	-19.53	Pass	
998.577333	30.89	4.07	-2.54	32.41	Debug	V	100	270	54.00	-21.59	Pass	
176.987333	33.74	1.51	-13.41	21.84	Debug	V	100	135	43.50	-21.66	Pass	
151.153	29.72	1.38	-9.29	21.81	Debug	V	100	315	43.50	-21.69	Pass	
183.195333	33.55	1.54	-14.11	20.98	Debug	V	100	180	43.50	-22.52	Pass	

Freq. (MHz)	Raw (dBuV)	Cable (dB)	Factor (dB)	Level (dBuV/m)	Emission Type	Pol (H/V)	Ht (cm)	Az (deg)	Limit (dBuV/m)	Margin (dB)	Pass/Fail	Comments
37.081	29.58	0.66	-13.14	17.10	Debug	V	300	45	40.00	-22.90	Pass	
80.763333	34.33	0.89	-18.92	16.30	Debug	H	180	0	40.00	-23.70	Pass	
31.034667	28.81	0.69	-9.91	19.59	Debug	H	100	135	40.00	-20.41	Pass	
177.116667	33.39	1.51	-13.42	21.48	Debug	V	100	180	43.50	-22.02	Pass	
984.835667	30.19	4.03	-2.69	31.54	Debug	H	100	45	54.00	-22.46	Pass	
145.915	28.89	1.35	-9.25	20.98	Debug	H	200	135	43.50	-22.52	Pass	
183.583333	32.99	1.55	-14.15	20.39	Debug	V	100	180	43.50	-23.11	Pass	
35.820	28.10	0.67	-12.46	16.30	Debug	V	200	315	40.00	-23.70	Pass	
81.442333	33.78	0.89	-18.77	15.90	Debug	V	100	135	40.00	-24.10	Pass	
87.682667	32.22	0.94	-17.34	15.82	Debug	V	100	180	40.00	-24.18	Pass	
998.614	21.74	4.07	-2.54	23.27	Peak	V	240	49	54.00	-30.73	Pass	
176.713	27.02	1.51	-13.38	15.15	Peak	V	129	166	43.50	-28.35	Pass	
151.450	22.22	1.38	-9.34	14.26	Peak	V	192	64	43.50	-29.24	Pass	
183.167	29.59	1.54	-14.10	17.03	Peak	V	103	175	43.50	-26.47	Pass	
36.891	22.42	0.66	-13.04	10.04	Peak	V	365	189	40.00	-29.96	Pass	

Note: Preview data was measured using a peak detector to identify frequencies of interest for formal measurement. Formal data consist of all frequencies in the preview list within 6 dB of specification limit or the top six frequencies. Failure in preview data does not necessarily constitute failure in formal data.

RE 1GHz – 10GHz

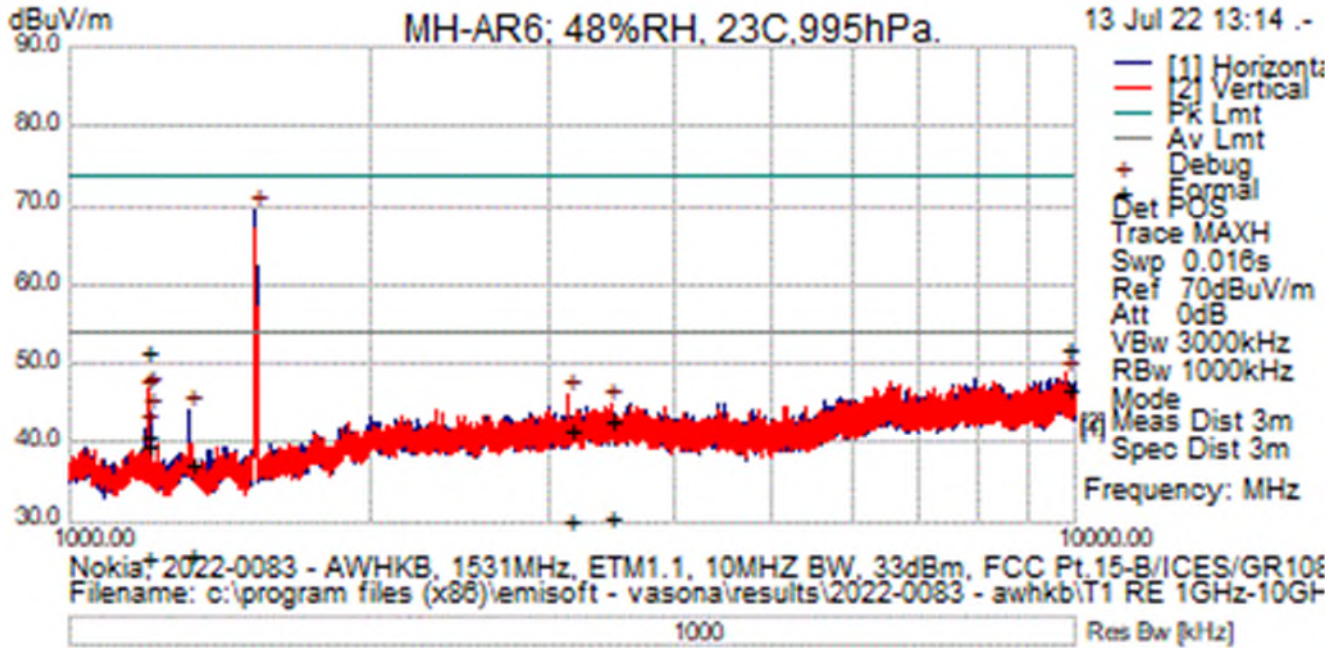

Test Information

Results Title	Radiated E 3m 1-18GHz
File Name	T1 RE 1GHz-10GHz.emi
Test Laboratory	MH-AR6; 48%RH, 23C,995hPa.
Test Engineer	GM
Test Software	Vasona by EMISoft, version 6.061
Equipment	Nokia
EUT Details	2022-0083 - AWHKB, 1531MHz, ETM1.1, 10MHZ BW, 33dBm
Configuration	FCC Pt.15-B/ICES/GR1089, RE 1GHz-10GHz FCC B 3 meter distance. 0dB Int Attn, RBW: 1MHz, VBW: 3MHz. MXE E1218, PA E11356, Horn E1074, RF cables AR5 Direct
Date	2022-07-13 13:15:13

Formal Data

Freq. (MHz)	Raw (dBuV)	Cable (dB)	Factor (dB)	Level (dBuV/m)	Emission Type	Pol (H/V)	Ht (cm)	Az (deg)	Limit (dBuV/m)	Margin (dB)	Pass/Fail	Comments
9830.590	41.96	5.70	-0.87	46.80	AvgMax	V	108	275	54.00	-7.20	Pass	
1199.978	49.26	1.76	-11.11	39.92	AvgMax	V	208	183	54.00	-14.08	Pass	
9830.590	47.33	5.70	-0.87	52.16	PeakMax	V	108	275	74.00	-21.84	Pass	
1199.978	61.10	1.76	-11.11	51.76	PeakMax	V	208	183	74.00	-22.24	Pass	
3459.100	31.49	3.23	-4.11	30.62	AvgMax	H	293	193	54.00	-23.38	Pass	
3138.400	31.57	3.01	-4.52	30.06	AvgMax	V	240	265	54.00	-23.94	Pass	
1319.427	34.73	1.86	-10.80	25.79	AvgMax	H	254	37	54.00	-28.21	Pass	
1198.600	34.76	1.76	-11.11	25.42	AvgMax	V	232	324	54.00	-28.58	Pass	
3459.100	43.72	3.23	-4.11	42.84	PeakMax	H	293	193	74.00	-31.16	Pass	
3138.400	43.09	3.01	-4.52	41.58	PeakMax	V	240	265	74.00	-32.42	Pass	
1198.600	50.18	1.76	-11.11	40.83	PeakMax	V	232	324	74.00	-33.17	Pass	
1319.427	46.32	1.86	-10.80	37.39	PeakMax	H	254	37	74.00	-36.61	Pass	

Preview Data

Freq. (MHz)	Raw (dBuV)	Cable (dB)	Factor (dB)	Level (dBuV/m)	Emission Type	Pol (H/V)	Ht (cm)	Az (deg)	Limit (dBuV/m)	Margin (dB)	Pass/Fail	Comments
1533.100	77.52	2.01	-10.05	69.48	Debug	H	280	315	54.00	15.48	Fail	
9830.500	43.98	5.70	-0.87	48.81	Debug	V	100	270	54.00	-5.19	Pass	
1201.000	56.11	1.76	-11.10	46.77	Debug	V	200	180	54.00	-7.23	Pass	
1198.600	55.72	1.76	-11.11	46.37	Debug	V	200	180	54.00	-7.63	Pass	
3138.400	47.68	3.01	-4.52	46.17	Debug	V	300	180	54.00	-7.83	Pass	
3459.100	45.90	3.23	-4.11	45.03	Debug	H	380	315	54.00	-8.97	Pass	
1319.500	53.13	1.86	-10.80	44.19	Debug	H	380	270	54.00	-9.81	Pass	
1207.900	53.14	1.77	-11.08	43.82	Debug	H	100	135	54.00	-10.18	Pass	
1191.700	51.11	1.76	-11.13	41.74	Debug	H	180	45	54.00	-12.26	Pass	

Note: Preview data was measured using a peak detector to identify frequencies of interest for formal measurement. Formal data consist of all frequencies in the preview list within 6 dB of specification limit or the top six frequencies. Failure in preview data does not necessarily constitute failure in formal data.

RE 10GHz – 18GHz

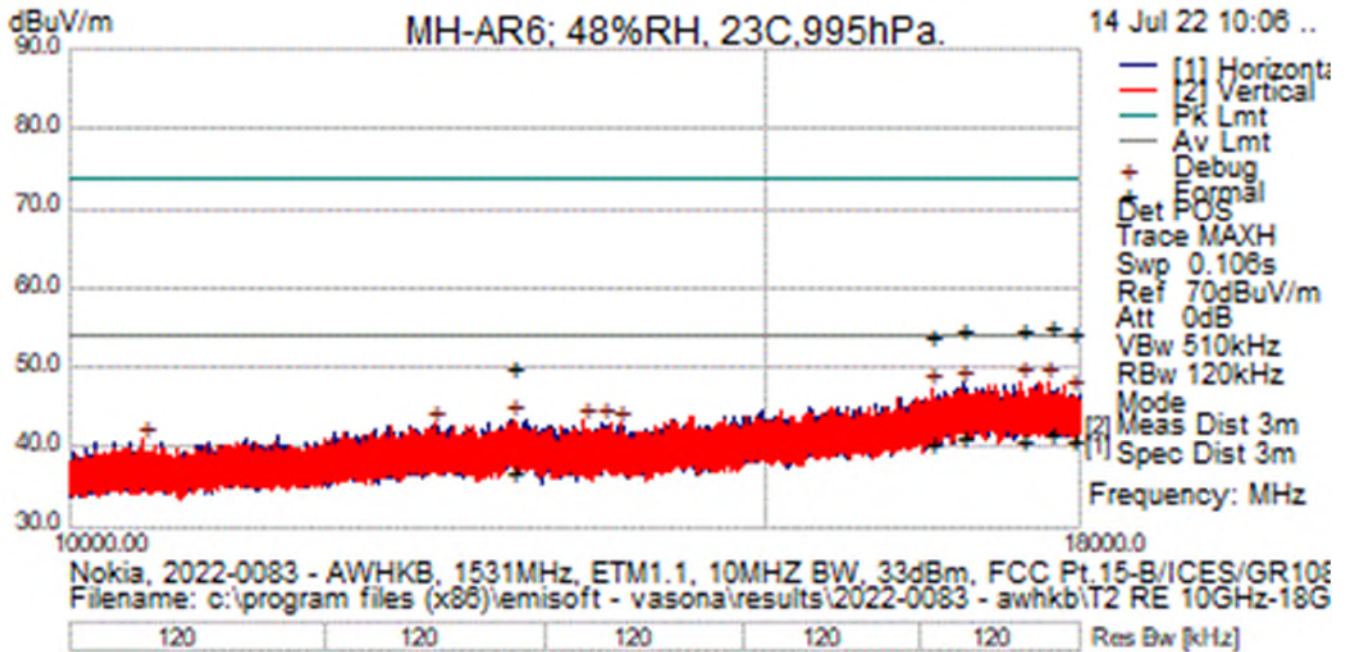

Test Information

Results Title	Radiated E 3m 1-18GHz
File Name	T2 RE 10GHz-18GHz.emi
Test Laboratory	MH-AR6; 48%RH, 23C,995hPa.
Test Engineer	GM
Test Software	Vasona by EMISoft, version 6.061
Equipment	Nokia
EUT Details	2022-0083 - AWHKB, 1531MHz, ETM1.1, 10MHz BW, 33dBm
Configuration	FCC Pt.15-B/ICES/GR1089, RE 10GHz-18GHz FCC B 3 meter distance. 0dB Int Attn, RBW: 1MHz, VBW: 3MHz. MXE E1218, PA E11356, Horn E1074, RF cables AR5 Direct
Date	2022-07-14 11:24:29

Formal Data

Freq. (MHz)	Raw (dBuV)	Cable (dB)	Factor (dB)	Level (dBuV/m)	Emission Type	Pol (H/V)	Ht (cm)	Az (deg)	Limit (dBuV/m)	Margin (dB)	Pass/Fail	Comments
17686.372	26.55	8.27	6.93	41.75	AvgMax	V	171	2	54.00	-12.25	Pass	
16832.053	26.23	8.06	7.12	41.41	AvgMax	H	221	267	54.00	-12.59	Pass	
17402.560	25.86	8.20	7.01	41.07	AvgMax	V	233	57	54.00	-12.93	Pass	
17915.893	25.61	8.32	7.03	40.96	AvgMax	H	163	197	54.00	-13.04	Pass	
16519.307	26.66	7.99	5.99	40.64	AvgMax	V	295	15	54.00	-13.36	Pass	
12946.560	26.10	6.95	3.90	36.95	AvgMax	H	366	48	54.00	-17.05	Pass	
17686.372	39.91	8.27	6.93	55.11	PeakMax	V	171	2	74.00	-18.89	Pass	
17402.560	39.49	8.20	7.01	54.70	PeakMax	V	233	57	74.00	-19.30	Pass	
16832.053	39.45	8.06	7.12	54.63	PeakMax	H	221	267	74.00	-19.37	Pass	
17915.893	39.10	8.32	7.03	54.45	PeakMax	H	163	197	74.00	-19.55	Pass	
16519.307	40.06	7.99	5.99	54.03	PeakMax	V	295	15	74.00	-19.97	Pass	
12946.560	39.34	6.95	3.90	50.19	PeakMax	H	366	48	74.00	-23.81	Pass	

Preview Data

Freq. (MHz)	Raw (dBuV)	Cable (dB)	Factor (dB)	Level (dBuV/m)	Emission Type	Pol (H/V)	Ht (cm)	Az (deg)	Limit (dBuV/m)	Margin (dB)	Pass/Fail	Comments
17402.560	33.00	8.20	7.01	48.22	Debug	V	300	0	54.00	-5.78	Pass	
17683.947	32.93	8.27	6.93	48.12	Debug	V	100	270	54.00	-5.88	Pass	
16831.253	32.71	8.06	7.12	47.89	Debug	H	280	0	54.00	-6.11	Pass	
16519.307	33.29	7.99	5.99	47.26	Debug	V	100	225	54.00	-6.74	Pass	
17915.893	31.19	8.32	7.03	46.54	Debug	H	280	135	54.00	-7.46	Pass	
12946.560	32.60	6.95	3.90	43.46	Debug	H	280	0	54.00	-10.54	Pass	
13489.813	32.42	7.11	3.72	43.25	Debug	V	100	45	54.00	-10.75	Pass	
13646.507	32.27	7.15	3.67	43.09	Debug	H	180	270	54.00	-10.91	Pass	
12367.040	33.54	6.72	2.55	42.81	Debug	V	300	135	54.00	-11.19	Pass	
13786.613	31.99	7.19	3.63	42.81	Debug	V	300	225	54.00	-11.19	Pass	
10444.800	34.68	5.94	0.22	40.83	Debug	V	100	180	54.00	-13.17	Pass	

Note: Preview data was measured using a peak detector to identify frequencies of interest for formal measurement. Formal data consist of all frequencies in the preview list within 6 dB of specification limit or the top six frequencies. Failure in preview data does not necessarily constitute failure in formal data.

7. FCC Section 2.1055 - Measurement of Frequency Stability

FCC Part 25 specified frequency tolerance for earth stations in 25.202(d) which requires the frequency tolerance to be within 10ppm.

7.1 AC Version

Testing was performed from 8-02-2022 through 8-03-2022 on the radio, which was located in the T-07 Thermal chamber of the Global Product Compliance Laboratory (GPCL) test facility located in Building 4, Room 4-280, Murray Hill, NJ, by Joe Bordonaro from GPCL

The temperatures to which the UUT were subjected ranged from a high temperature of +50°C system ambient to a low temperature of -30°C system ambient with measurements recorded at 10C increments.

Transmit frequency error measures the deviation between the actual transmit frequency and the assigned frequency. The transmit frequency error in this case was measured by capturing the transmitted signal using a receiving antenna and then cabling it to an MXA signal analyzer. The system level frequency stability testing resulted in compliance with established design criteria.

Frequency Block Tested AWHKB 1531MHz RRH (CF = 1531MHz)

Baseline Measurement at +25°C

Transmit Frequency Deviation at +25°C at 100% of Nominal Voltage, 120VAC	
Time (minutes)	Transmit Carrier Deviation (Hz)
0	-56.64 mHz
0.5	443.99 mHz
1.0	791.271 mHz
1.5	67.251 mHz
2.0	-837.7 mHz
2.5	-525.3 mHz
3.0	1.1318 Hz
FCC SPECIFICATION	1531 MHz (±0.05ppm) ±0.05ppm = ± 75.65Hz
FCC RESULT	Pass

Transmit Frequency Deviation at +50°C at 100% of Nominal Voltage, 120VAC	
Time (minutes)	Transmit Carrier Deviation (Hz)
0	314.65 mHz
0.5	-713.9 mHz
1.0	682.05 mHz
1.5	221.14 mHz
2.0	-293.7 mHz
2.5	-1.3142 Hz
3.0	221.84 mHz
FCC SPECIFICATION	1531 MHz (±0.05ppm) ±0.05ppm = ± 75.65Hz
FCC RESULT	Pass

Transmit Frequency Deviation at +40°C at 100% of Nominal Voltage, 120VAC	
Time (minutes)	Transmit Carrier Deviation (Hz)
0	-289.6 mHz
0.5	224.66 mHz
1.0	-1.6633
1.5	-1.0047
2.0	458.96 mHz
2.5	70.842 mHz
3.0	139.35 mHz
FCC SPECIFICATION	1531 MHz (±0.05ppm) ±0.05ppm = ± 75.65Hz
FCC RESULT	Pass

Transmit Frequency Deviation at +30°C at 100% of Nominal Voltage, 120VAC	
Time (minutes)	Transmit Carrier Deviation (Hz)
0	-524.8mHz
0.5	471.46 mHz
1.0	230.76 mHz
1.5	998.97 mHz
2.0	-83.06 mHz
2.5	-481.5mHz
3.0	-183.8 mHz
FCC SPECIFICATION	1531 MHz (±0.05ppm) ±0.05ppm = ± 75.65Hz
FCC RESULT	Pass

Transmit Frequency Deviation at +20°C at 100% of Nominal Voltage, 120VAC	
Time (minutes)	Transmit Carrier Deviation (Hz)
0	1.7438
0.5	-414.6 mHz
1.0	241.81 mHz
1.5	-1.0420
2.0	-1.3153
2.5	-125.9 mHz
3.0	-485.7 mHz
FCC SPECIFICATION	1531 MHz (±0.05ppm) ±0.05ppm = ± 75.65Hz
FCC RESULT	Pass

Transmit Frequency Deviation at +10°C at 100% of Nominal Voltage, 120VAC	
Time (minutes)	Transmit Carrier Deviation (Hz)
0	-21.04 mHz
0.5	234.67 mHz
1.0	193.28 mHz
1.5	87.518 mHz
2.0	472.37 mHz
2.5	-332.1 mHz
3.0	-483.7 mHz
FCC SPECIFICATION	1531 MHz (±0.05ppm) ±0.05ppm = ± 75.65Hz
FCC RESULT	Pass

Transmit Frequency Deviation at 0°C at 100% of Nominal Voltage, 120VAC	
Time (minutes)	Transmit Carrier Deviation (Hz)
0	226.30 mHz
0.5	482.60 mHz
1.0	-537.4 mHz
1.5	328.47 mHz
2.0	546.21 mHz
2.5	-397.8 mHz
3.0	-965.4 mHz
FCC SPECIFICATION	1531 MHz (±0.05ppm) ±0.05ppm = ± 75.65Hz
FCC RESULT	Pass

Transmit Frequency Deviation at -10°C at 100% of Nominal Voltage, 120VAC	
Time (minutes)	Transmit Carrier Deviation (Hz)
0	1.1009
0.5	-88.72 mHz
1.0	-304.9 mHz
1.5	211.65 mHz
2.0	576.22 mHz
2.5	-1.3069
3.0	80.425 mHz
FCC SPECIFICATION	1531 MHz (±0.05ppm) ±0.05ppm = ± 75.65Hz
FCC RESULT	Pass

Transmit Frequency Deviation at -20°C at 100% of Nominal Voltage, 120VAC	
Time (minutes)	Transmit Carrier Deviation (Hz)
0	318.90 mHz
0.5	-352.1 mHz
1.0	791.21 mHz
1.5	-582.0 mHz
2.0	-81.86 mHz
2.5	86.057 mHz
3.0	1.0464
FCC SPECIFICATION	1531 MHz (±0.05ppm) ±0.05ppm = ± 75.65Hz
FCC RESULT	Pass

Transmit Frequency Deviation at -30°C at 100% of Nominal Voltage, 120VAC	
Time (minutes)	Transmit Carrier Deviation (Hz)
0	120.34 mHz
0.5	444.18 mHz
1.0	-393.9 mHz
1.5	44.974 mHz
2.0	500.27 mHz
2.5	791.72 mHz
3.0	1.2829
FCC SPECIFICATION	1531 MHz (±0.05ppm) ±0.05ppm = ± 75.65Hz
FCC RESULT	Pass

Upon return to +25°C.

Transmit Frequency Deviation at +25°C at 100% of Nominal Voltage, 120VAC	
Time (minutes)	Transmit Carrier Deviation (Hz)
0	-177.1 mHz
0.5	1.0340
1.0	90.158 mHz
1.5	334.17 mHz
2.0	279.70 mHz
2.5	1.0093
3.0	-464.5 mHz
FCC SPECIFICATION	1531 MHz (±0.05ppm) ±0.05ppm = ± 75.65Hz
FCC RESULT	Pass

Transmit Frequency Deviation at +25°C at 103% of Nominal Voltage, 123.6VAC	
Time (minutes)	Transmit Carrier Deviation (Hz)
0	-184.7 mHz
0.5	-10.80 mHz
1.0	-480.0 mHz
1.5	795.39 mHz
2.0	-481.90 mHz
2.5	75.813 mHz
3.0	-957.8 mHz
938 MHz (±0.05ppm) ±0.05ppm = ±46.9Hz	1531 MHz (±0.05ppm) ±0.05ppm = ± 75.65Hz
FCC RESULT	Pass

Transmit Frequency Deviation at +25°C at 106% of Nominal Voltage, 127.2VAC	
Time (minutes)	Transmit Carrier Deviation (Hz)
0	625.33 mHz
0.5	500.4 mHz
1.0	154.06 mHz
1.5	-742.1 mHz
2.0	290.49 mHz
2.5	-482.9 mHz
3.0	1.0834
FCC SPECIFICATION	1531 MHz (±0.05ppm) ±0.05ppm = ± 75.65Hz
FCC RESULT	Pass

Transmit Frequency Deviation at +25°C at 109% of Nominal Voltage, 130.8VAC	
Time (minutes)	Transmit Carrier Deviation (Hz)
0	181.15 mHz
0.5	-234.5 mHz
1.0	1.0644
1.5	631.98 mHz
2.0	397.94 mHz
2.5	-342.5 mHz
3.0	44.875 mHz
FCC SPECIFICATION	1531 MHz (±0.05ppm) ±0.05ppm = ± 75.65Hz
FCC RESULT	Pass

Transmit Frequency Deviation at +25°C at 112% of Nominal Voltage, 134.4VAC	
Time (minutes)	Transmit Carrier Deviation (Hz)
0	224.86 mHz
0.5	-920.2 mHz
1.0	-154.6 mHz
1.5	-583.9 mHz
2.0	791.81 mHz
2.5	-79.45 mHz
3.0	357.1 mHz
FCC SPECIFICATION	1531 MHz (±0.05ppm) ±0.05ppm = ± 75.65Hz
FCC RESULT	Pass

Transmit Frequency Deviation at +25°C at 115% of Nominal Voltage, 138VAC	
Time (minutes)	Transmit Carrier Deviation (Hz)
0	-59.86 mHz
0.5	-190.2 mHz
1.0	117.90 mHz
1.5	1.0992
2.0	718.60 mHz
2.5	558.17 mHz
3.0	-117.0 mHz
FCC SPECIFICATION	1531 MHz (±0.05ppm) ±0.05ppm = ± 75.65Hz
FCC RESULT	Pass

Transmit Frequency Deviation at +25°C at 100% of Nominal Voltage, 120VAC	
Time (minutes)	Transmit Carrier Deviation (Hz)
0	-465.1 mHz
0.5	577.81 mHz
1.0	591.20 mHz
1.5	328.91 mHz
2.0	909.52 mHz
2.5	-83.61 mHz
3.0	649.21 mHz
FCC SPECIFICATION	1531 MHz (±0.05ppm) ±0.05ppm = ± 75.65Hz
FCC RESULT	Pass

Transmit Frequency Deviation at +25°C at -3% of Nominal Voltage, 116.4VAC	
Time (minutes)	Transmit Carrier Deviation (Hz)
0	-329.6 mHz
0.5	889.56 mHz
1.0	-382.2 mHz
1.5	734.52 mHz
2.0	-259.3 mHz
2.5	721.04 mHz
3.0	-337.0 mHz
FCC SPECIFICATION	1531 MHz (±0.05ppm) ±0.05ppm = ± 75.65Hz
FCC RESULT	Pass

Transmit Frequency Deviation at +25°C at -6% of Nominal Voltage, 112.8VAC	
Time (minutes)	Transmit Carrier Deviation (Hz)
0	-4.611 mHz
0.5	-837.1 mHz
1.0	434.36 mHz
1.5	-368.2 mHz
2.0	211.06 mHz
2.5	289.30 mHz
3.0	673.21 mHz
FCC SPECIFICATION	1531 MHz (±0.05ppm) ±0.05ppm = ± 75.65Hz
FCC RESULT	Pass

Transmit Frequency Deviation at +25°C at -9% of Nominal Voltage, 109.2VAC	
Time (minutes)	Transmit Carrier Deviation (Hz)
0	-233.9 mHz
0.5	215.89 mHz
1.0	29.030 mHz
1.5	225.52 mHz
2.0	78.214 mHz
2.5	434.39 mHz
3.0	-70.59 mHz
FCC SPECIFICATION	1531 MHz (±0.05ppm) ±0.05ppm = ± 75.65Hz
FCC RESULT	Pass

Transmit Frequency Deviation at +25°C at -12% of Nominal Voltage, 105.6VAC	
Time (minutes)	Transmit Carrier Deviation (Hz)
0	-187.1 mHz
0.5	379.07 mHz
1.0	508.17 mHz
1.5	-394.4 mHz
2.0	-628.2 mHz
2.5	760.96 mHz
3.0	-510.7 mHz
FCC SPECIFICATION	1531 MHz (±0.05ppm) ±0.05ppm = ± 75.65Hz
FCC RESULT	Pass

Transmit Frequency Deviation at +25°C at -15% of Nominal Voltage, 102VAC	
Time (minutes)	Transmit Carrier Deviation (Hz)
0	667.43 mHz
0.5	878.69 mHz
1.0	712.48 mHz
1.5	-520.2 mHz
2.0	675.41 mHz
2.5	1.3091
3.0	168.09 mHz
FCC SPECIFICATION	1531 MHz (±0.05ppm) ±0.05ppm = ± 75.65Hz
FCC RESULT	Pass

Chamber Plot

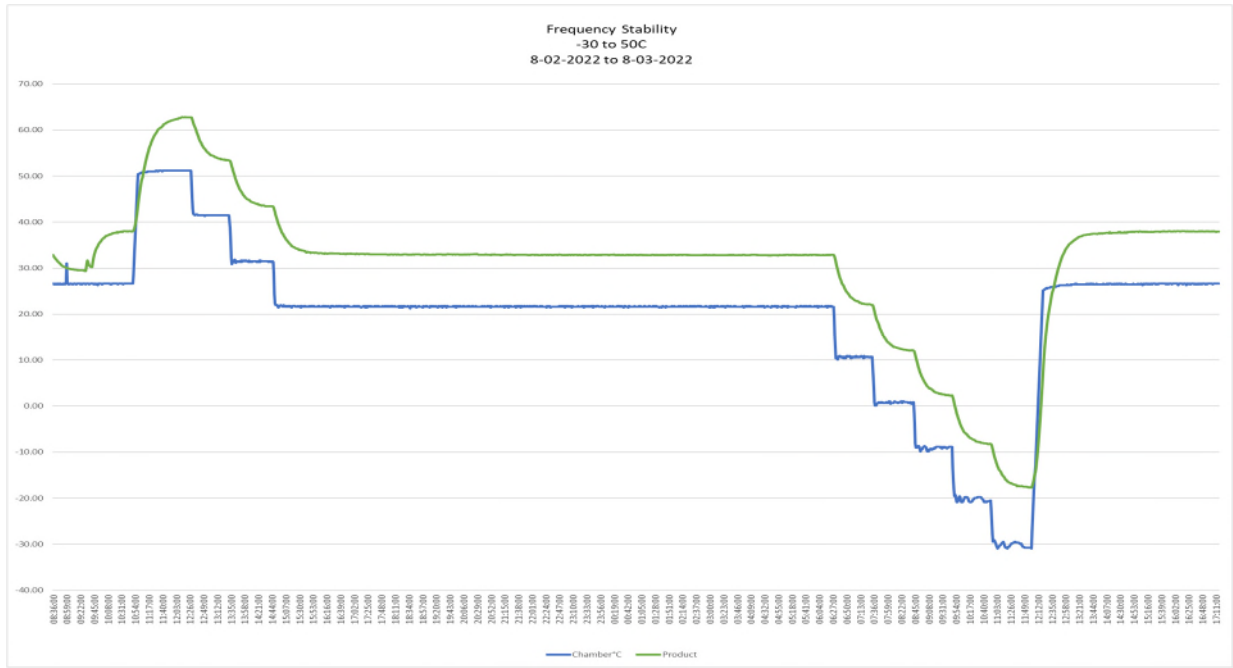

7.2 DC Version

Frequency Stability testing was completed on AWHKB 5G AirScale Micro RRH 4T4R B24 - Ligado Unit with Center Frequency 1531 MHz. Testing was performed from 7/28/2022 through 8/01/2022 on the radio, which was located in the T07 Thermal chamber of the Global Product Compliance Laboratory (GPCL) test facility located in Building 4, Room 4-280, Murray Hill, NJ, by Joe Bordonaro from GPCL.

The temperatures to which the UUT were subjected ranged from a high temperature of +50°C system ambient to a low temperature of -30°C system ambient with measurements recorded at 10C increments

Frequency Stability performance was verified by measuring Frequency Tolerance using an MXA Signal Analyzer. Frequency Tolerance is a measurement of the difference between the actual transmit frequency and the assigned frequency (1531 MHz).

Frequency Block Tested: AWHKB 1531MHz RRH (CF = 1531MHz)

Baseline Measurement at +25°C

Transmit Frequency Deviation at +25°C at 100% of Nominal Voltage, -48VDC	
Time (minutes)	Transmit Carrier Deviation (Hz)
0	16.681
0.5	17.658
1.0	16.857
1.5	15.974
2.0	17.208
2.5	16.197
3.0	17.280
FCC SPECIFICATION	1531 MHz (±0.05ppm) ±0.05ppm = ±75.65Hz
FCC RESULT	PASS

Transmit Frequency Deviation at +50°C at 100% of Nominal Voltage, -48VDC	
Time (minutes)	Transmit Carrier Deviation (Hz)
0	17.830
0.5	16.184
1.0	17.083
1.5	18.093
2.0	16.077
2.5	17.428
3.0	16.926
FCC SPECIFICATION	1531 MHz (±0.05ppm) ±0.05ppm = ±75.65Hz
FCC RESULT	PASS

Transmit Frequency Deviation at +40°C at 100% of Nominal Voltage, -48VDC	
Time (minutes)	Transmit Carrier Deviation (Hz)
0	17.842
0.5	16.120
1.0	17.814
1.5	15.951
2.0	17.871
2.5	17.044
3.0	16.357
FCC SPECIFICATION	1531MHz (±0.05ppm) ±0.05ppm = ±75.65Hz
FCC RESULT	PASS

Transmit Frequency Deviation at +30°C at 100% of Nominal Voltage, -48VDC	
Time (minutes)	Transmit Carrier Deviation (Hz)
0	17.817
0.5	16.288
1.0	17.431
1.5	16.455
2.0	17.411
2.5	17.280
3.0	16.866
FCC SPECIFICATION	1531 MHz (±0.05ppm) ±0.05ppm = ±75.65Hz
FCC RESULT	PASS

Transmit Frequency Deviation at +20°C at 100% of Nominal Voltage, -48VDC	
Time (minutes)	Transmit Carrier Deviation (Hz)
0	16.842
0.5	17.665
1.0	16.744
1.5	17.447
2.0	16.286
2.5	15.863
3.0	16.893
FCC SPECIFICATION	1531 MHz (±0.05ppm) ±0.05ppm = ±75.65Hz
FCC RESULT	PASS

Transmit Frequency Deviation at +10°C at 100% of Nominal Voltage, -48VDC	
Time (minutes)	Transmit Carrier Deviation (Hz)
0	17.838
0.5	16.677
1.0	16.839
1.5	16.369
2.0	17.221
2.5	16.656
3.0	17.057
FCC SPECIFICATION	1531 MHz (±0.05ppm) ±0.05ppm = ±75.65Hz
FCC RESULT	PASS

Transmit Frequency Deviation at 0°C at 100% of Nominal Voltage, -48VDC	
Time (minutes)	Transmit Carrier Deviation (Hz)
0	16.507
0.5	16.169
1.0	15.819
1.5	16.824
2.0	16.965
2.5	17.502
3.0	16.620
FCC SPECIFICATION	1531 MHz (±0.05ppm) ±0.05ppm = ±75.65Hz
FCC RESULT	PASS

Transmit Frequency Deviation at -10°C at 100% of Nominal Voltage, -48VDC	
Time (minutes)	Transmit Carrier Deviation (Hz)
0	16.224
0.5	17.938
1.0	16.851
1.5	16.836
2.0	17.627
2.5	16.730
3.0	15.771
FCC SPECIFICATION	1531 MHz (±0.05ppm) ±0.05ppm = ±75.65Hz
FCC RESULT	PASS

Transmit Frequency Deviation at -20°C at 100% of Nominal Voltage, -48VDC	
Time (minutes)	Transmit Carrier Deviation (Hz)
0	15.986
0.5	16.363
1.0	16.017
1.5	15.571
2.0	16.600
2.5	17.054
3.0	16.529
FCC SPECIFICATION	1531 MHz (±0.05ppm) ±0.05ppm = ±75.65Hz
FCC RESULT	PASS

Transmit Frequency Deviation at -30°C at 100% of Nominal Voltage, -48VDC	
Time (minutes)	Transmit Carrier Deviation (Hz)
0	16.137
0.5	17.477
1.0	16.607
1.5	17.173
2.0	16.294
2.5	15.724
3.0	17.235
FCC SPECIFICATION	1531 MHz (±0.05ppm) ±0.05ppm = ±75.65Hz
FCC RESULT	PASS

Upon return to +25°C.

Transmit Frequency Deviation at +25°C at 100% of Nominal Voltage, -48VDC	
Time (minutes)	Transmit Carrier Deviation (Hz)
0	15.615
0.5	16.352
1.0	16.336
1.5	17.769
2.0	17.847
2.5	17.000
3.0	16.928
FCC SPECIFICATION	1531 MHz (±0.05ppm) ±0.05ppm = ±75.65Hz
FCC RESULT	PASS

Transmit Frequency Deviation at +25°C at 103% of Nominal Voltage, -49.44VDC	
Time (minutes)	Transmit Carrier Deviation (Hz)
0	16.658
0.5	16.361
1.0	17.049
1.5	16.040
2.0	16.511
2.5	16.744
3.0	17.059
FCC SPECIFICATION	1531 MHz (±0.05ppm) ±0.05ppm = ±75.65Hz
FCC RESULT	PASS

Transmit Frequency Deviation at +25°C at 106% of Nominal Voltage, -50.88VDC	
Time (minutes)	Transmit Carrier Deviation (Hz)
0	15.730
0.5	17.870
1.0	16.345
1.5	15.076
2.0	15.534
2.5	16.443
3.0	16.893
FCC SPECIFICATION	1531 MHz (±0.05ppm) ±0.05ppm = ±75.65Hz
FCC RESULT	PASS

Transmit Frequency Deviation at +25°C at 109% of Nominal Voltage, -52.32VDC	
Time (minutes)	Transmit Carrier Deviation (Hz)
0	16.645
0.5	16.824
1.0	17.623
1.5	16.614
2.0	17.429
2.5	16.602
3.0	16.112
FCC SPECIFICATION	1531 MHz (±0.05ppm) ±0.05ppm = ±75.65Hz
FCC RESULT	PASS

Transmit Frequency Deviation at +25°C at 112% of Nominal Voltage, -53.76VDC	
Time (minutes)	Transmit Carrier Deviation (Hz)
0	16.594
0.5	17.215
1.0	17.533
1.5	16.943
2.0	16.623
2.5	17.222
3.0	15.935
FCC SPECIFICATION	1531 MHz (±0.05ppm) ±0.05ppm = ±75.65Hz
FCC RESULT	PASS

Transmit Frequency Deviation at +25°C at 115% of Nominal Voltage, -55.20VDC	
Time (minutes)	Transmit Carrier Deviation (Hz)
0	17.034
0.5	16.160
1.0	16.665
1.5	18.727
2.0	16.576
2.5	17.075
3.0	16.785
FCC SPECIFICATION	1531 MHz (±0.05ppm) ±0.05ppm = ±75.65Hz
FCC RESULT	PASS

Transmit Frequency Deviation at +25°C at 100% of Nominal Voltage, -48.0VDC	
Time (minutes)	Transmit Carrier Deviation (Hz)
0	16.936
0.5	17.323
1.0	16.156
1.5	17.127
2.0	15.389
2.5	17.025
3.0	16.778
FCC SPECIFICATION	1531 MHz (±0.05ppm) ±0.05ppm = ±75.65Hz
FCC RESULT	PASS

Transmit Frequency Deviation at +25°C at -3% of Nominal Voltage, -46.56VDC	
Time (minutes)	Transmit Carrier Deviation (Hz)
0	16.575
0.5	16.958
1.0	16.089
1.5	17.587
2.0	16.537
2.5	17.637
3.0	16.036
FCC SPECIFICATION	1531 MHz (±0.05ppm) ±0.05ppm = ±75.65Hz
FCC RESULT	PASS

Transmit Frequency Deviation at +25°C at -6% of Nominal Voltage, -45.12VDC	
Time (minutes)	Transmit Carrier Deviation (Hz)
0	16.094
0.5	16.905
1.0	15.988
1.5	16.817
2.0	16.467
2.5	17.640
3.0	16.536
FCC SPECIFICATION	1531 MHz (±0.05ppm) ±0.05ppm = ±75.65Hz
FCC RESULT	PASS

Transmit Frequency Deviation at +25°C at -9% of Nominal Voltage, -43.68VDC	
Time (minutes)	Transmit Carrier Deviation (Hz)
0	16.357
0.5	17.189
1.0	16.772
1.5	15.604
2.0	16.370
2.5	16.332
3.0	17.613
FCC SPECIFICATION	1531 MHz (±0.05ppm) ±0.05ppm = ±75.65Hz
FCC RESULT	PASS

Transmit Frequency Deviation at +25°C at -12% of Nominal Voltage, -42.24VDC	
Time (minutes)	Transmit Carrier Deviation (Hz)
0	15.837
0.5	16.936
1.0	16.078
1.5	16.592
2.0	16.174
2.5	17.941
3.0	16.716
FCC SPECIFICATION	1531 MHz (±0.05ppm) ±0.05ppm = ±75.65Hz
FCC RESULT	PASS

Transmit Frequency Deviation at +25°C at -15% of Nominal Voltage, -40.80VDC	
Time (minutes)	Transmit Carrier Deviation (Hz)
0	16.729
0.5	16.943
1.0	15.934
1.5	18.042
2.0	16.188
2.5	17.846
3.0	16.381
FCC SPECIFICATION	1531 MHz (±0.05ppm) ±0.05ppm = ±75.65Hz
FCC RESULT	PASS

Chamber Plot

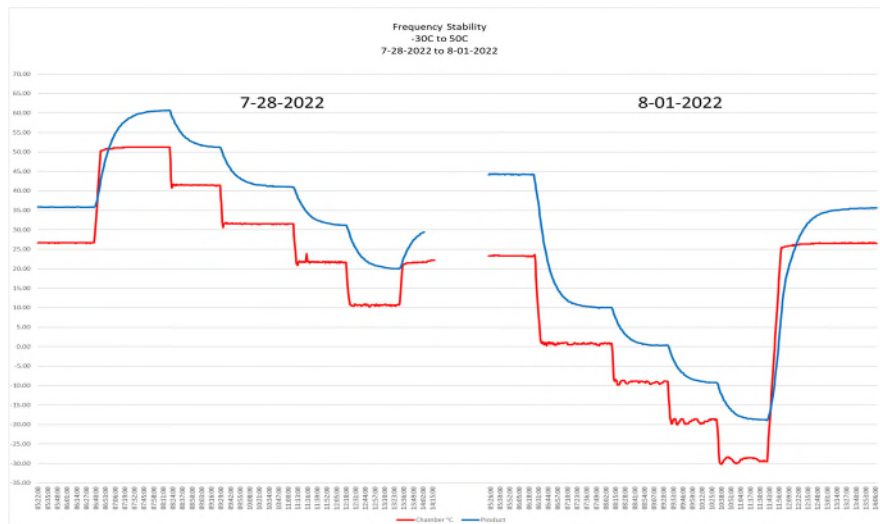

Radiated Emission Test

30MHz- 1GHz



1GHz – 18GHz

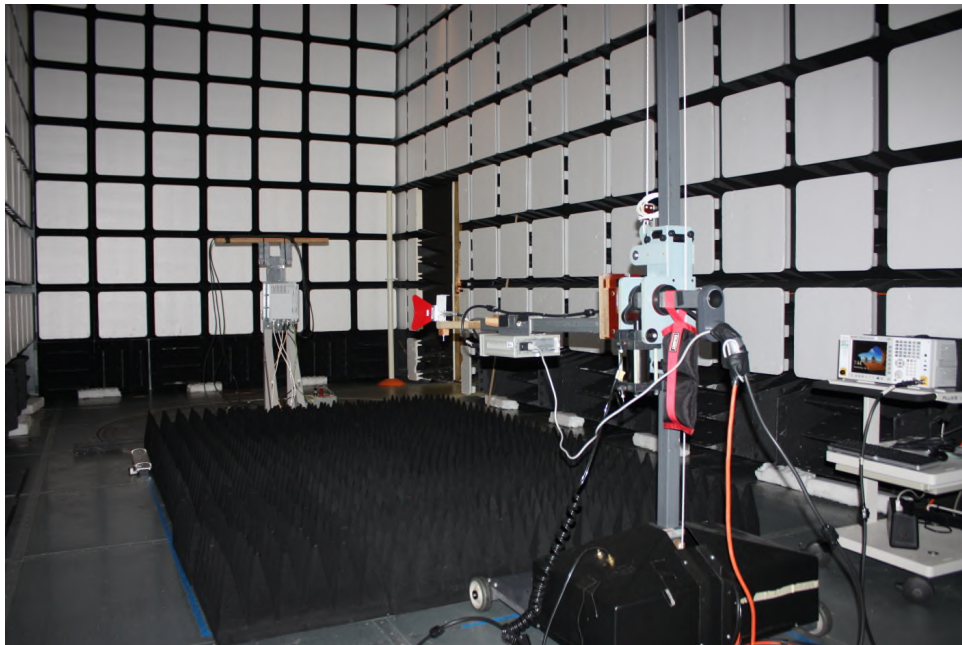

Frequency Stability Test



9. Test Equipment

Radio Test Equipment

Asset ID	Manufacturer	Type	Description	Model	Serial	Calibration Date	Calibration Due
E896	Agilent Technologies	Network Analyzer	10 MHz - 40 GHz	N5230C	MY49000897	2021-03-03	2023-03-03
E1271	K & L Microwave	Filter, Band Reject		3TNF-1000/2000-N/N	1	CNR-V	CNR-V
E1338	KeySight Technologies	MXA Signal Analyzer		N9020B	MY57430927	2021-01-07	2023-01-07
E1156	Weinschel	Attenuator	10dB 0.05GHz-26GHz 25W	74-10-12	1069	CNR-V	CNR-V
E1154	Weinschel	Attenuator	30dB 25W 0.05GHz-26GHz	74-30-12	1065	CNR-V	CNR-V
Customer Provide Equipment							
	Utiflex Micro-coax	RF Cable		MFR6 64639 858616-001	UFB142A-Q-0760-2002G0	CNR-V	CNR-V
	Mini Circuit	RF Switch		ZTS-8SP8T-63	1170228003	CNR	CNR
	Mini Circuit	RF Switch		RCM-202	0211020002	CNR	CNR
	K & L Microwave	Filter, Band Reject		3TNF-1000/2000-N/N	2	CNR-V	CNR-V
	MCE/Weinschel	Attenuator	6dB 25W DC-18GHz	6430-6-34 LIM	BN3225	CNR-V	CNR-V

CNR: Calibration Not Required

CNR-V: Calibration Not Required, Must Be Verified

Test Dates: 7/20/2022 – 8/3/2022, 9/15/2022

Radiated Emission Test Equipment

Asset ID	Manufacturer	Type	Description	Model	Serial	Calibration Date	Calibration Due
EIH43	A.H. Systems Inc.	Biological Antenna	25 - 2000 MHz	SAS-521-2	511	2021-09-09	2023-09-09
E1527	ETS Lindgren	Horn Antenna	Double Ridged Horn 10-40 GHz	3116C	00227823	2020-08-13	2022-08-13
E1074	ETS Lindgren	Horn Antenna	Double-Ridged Waveguide Horn 1-18 GHz	3117	00135194	2021-08-03	2023-08-03
E1356	Hewlett Packard	Pre-Amplifier	Pre-Amplifier 1-26.5GHz	8449B	3008A01353	2020-10-21	2022-10-21
E1218	KeySight Technologies	EMI Receiver	MXE EMI Receiver 44 GHz	N9038A	MY54130037	2021-12-29	2023-12-29
E1529	Micro-Coax	Cable	1-40 GHz, 2.92 (m)+2.92 (m), 237 inch., armor, 90 degree bent	UFB142A-0-2370-2002G0	SFC235841	CNR-V	CNR-V
E1528	Micro-Coax	Cable	1-40 GHz, 2.92 (m)+2.92 (m), 36 inch., armor, 90 degree bent	UFB142A-Q-0360-2002G0	SFC235840	CNR-V	CNR-V
E1387	Miteq	Pre-Amplifier	18 GHz-40 GHz, 45dBm	TTA1840-35-HG	2034	2020-08-28	2022-08-28
E507	Sonoma Instrument Co.	Amplifier	9KHz-1GHz	310	185794	2020-10-20	2022-10-20
E1187	Starrett	Tape Measure	30m Precision Tape Measure	530-30cm	13504222	CNR	CNR

CNR-V: Calibration Not Required, Must Be Verified

CNR: Calibration Not Required

Test Dates: 7/13/2022 – 7/19/2022

Frequency Stability Test Equipment

Asset ID	Manufacturer	Description	Model	Serial	Calibration Date	Calibration Due
TH529-T07	Envirotronics	Controller	Envirotronics Solutions Plus	SP000841	2021-03-08	2023-03-08
TH-T07	Envirotronics	Thermal Chamber	N/A	0999-4721	2020-09-18	2022-09-18
TH303	Yokogawa	Power Analyzer	WT500	91L222240	2021-12-10	2023-12-10
TH089	Yokogawa	Data Logger	GP10	S5U909019	2021-02-25	2023-02-25
EIH74	KeySight Technologies	MXA Signal Analyzer	N9020B	MY57120303	2020-12-21	2022-12-21

Test Dates: 7/28/2022 – 8/3/2022

10. NVLAP Certificate of Accreditation

United States Department of Commerce
National Institute of Standards and Technology

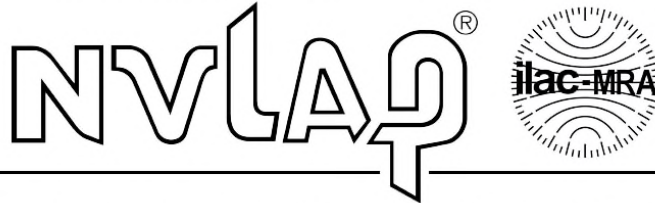

Certificate of Accreditation to ISO/IEC 17025:2017

NVLAP LAB CODE: 100275-0

Nokia, Global Product Compliance Lab
Murray Hill, NJ

*is accredited by the National Voluntary Laboratory Accreditation Program for specific services,
listed on the Scope of Accreditation, for:*

Electromagnetic Compatibility & Telecommunications

*This laboratory is accredited in accordance with the recognized International Standard ISO/IEC 17025:2017.
This accreditation demonstrates technical competence for a defined scope and the operation of a laboratory quality
management system (refer to joint ISO-ILAC-IAF Communique dated January 2009).*

2021-09-24 through 2022-09-30
Effective Dates



[Handwritten Signature]

For the National Voluntary Laboratory Accreditation Program