

5G NR Emission Bandwidth - QPSK

Bottom Channel

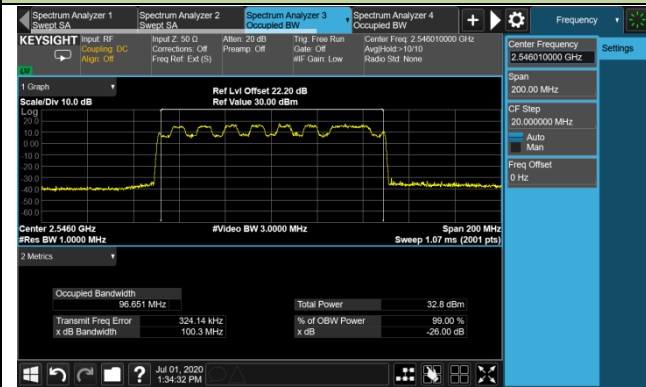

Middle Channel

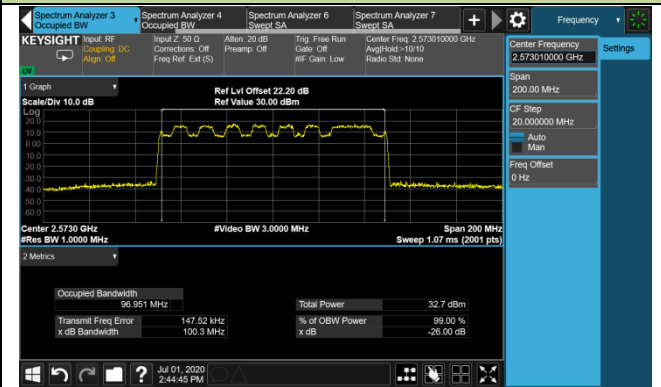

Top Channel

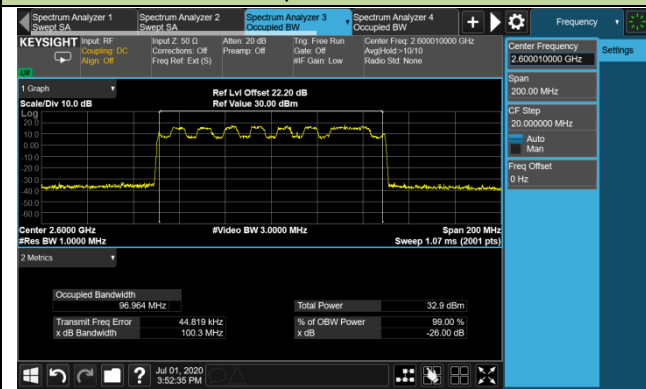

5G NR Emission Bandwidth - 16QAM

Bottom Channel

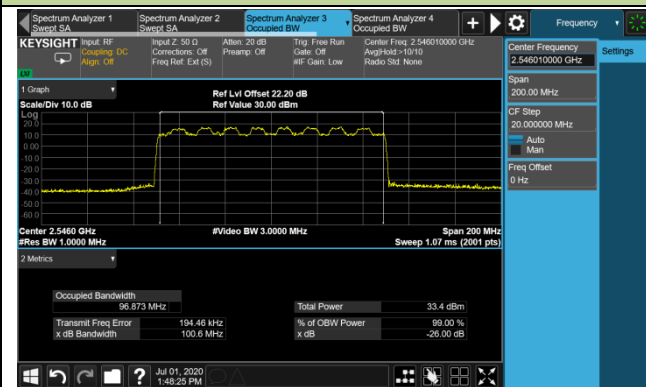

Middle Channel

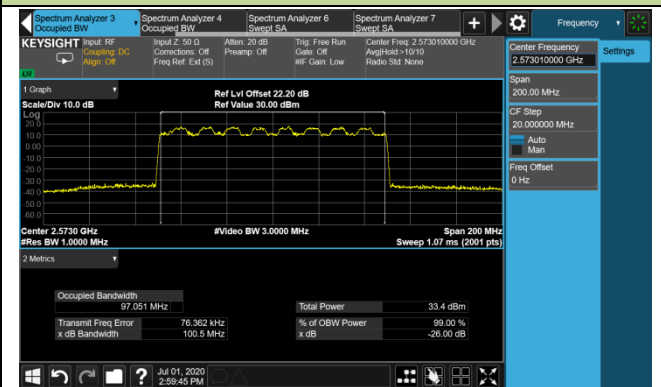

Top Channel

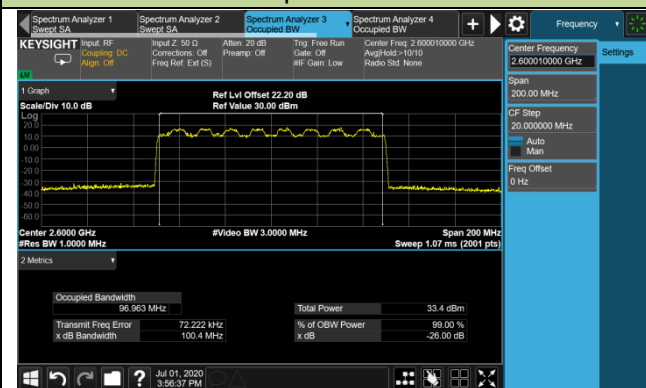

5G NR Emission Bandwidth - 64QAM

Bottom Channel

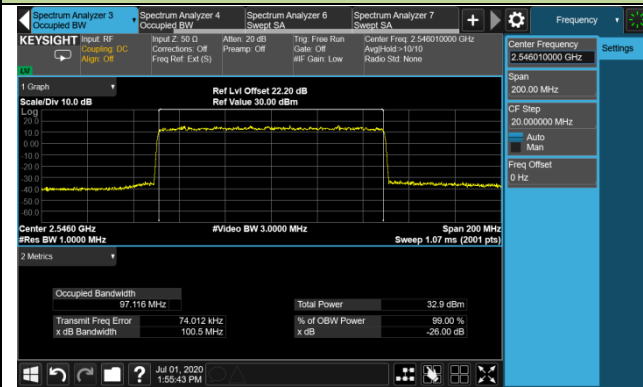

Middle Channel

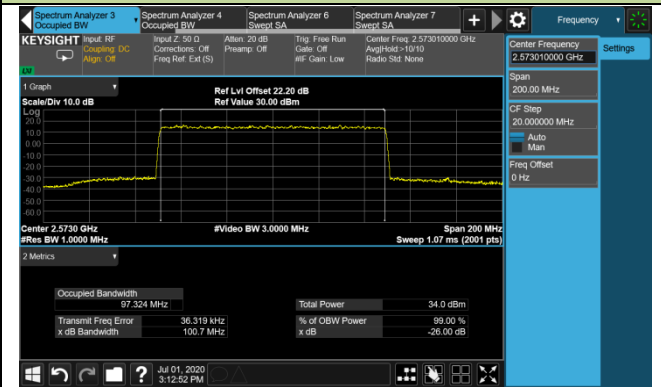

Top Channel

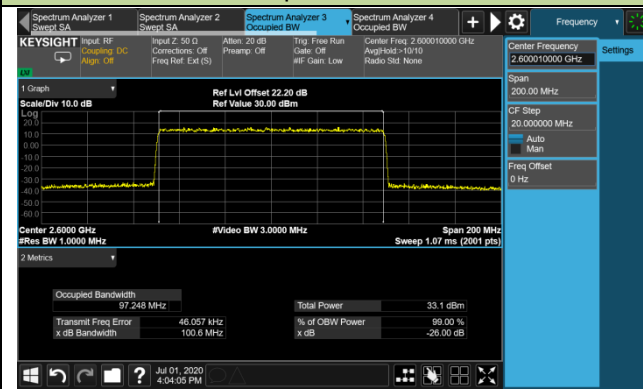

5G NR Emission Bandwidth - 256QAM

Bottom Channel

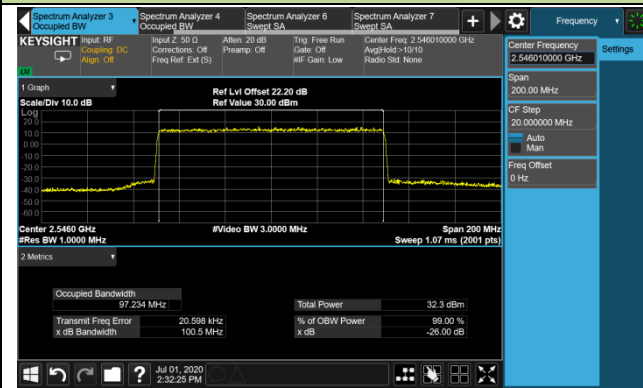

Middle Channel

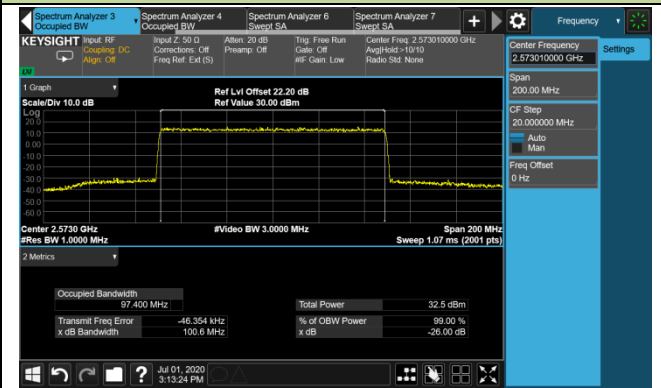

Top Channel

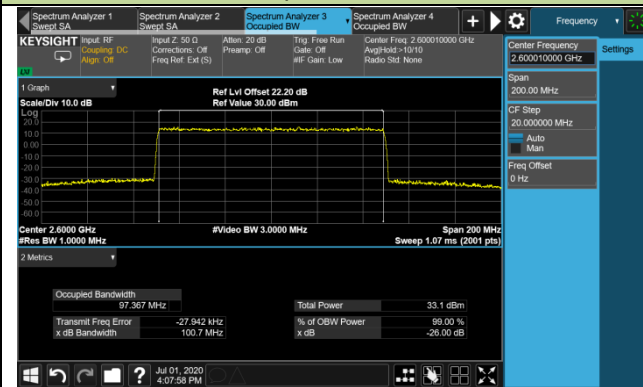

LTE Emission Bandwidth - QPSK

Bottom Channel

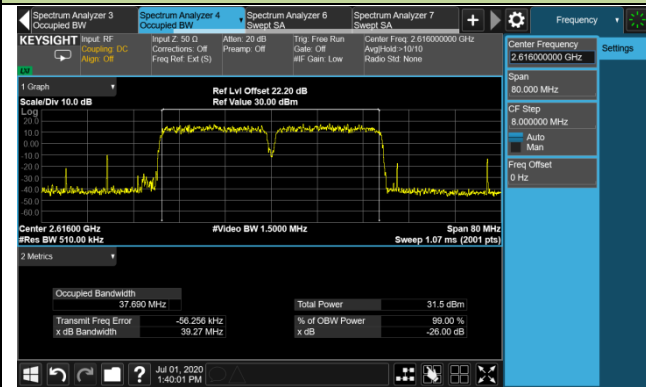

Middle Channel

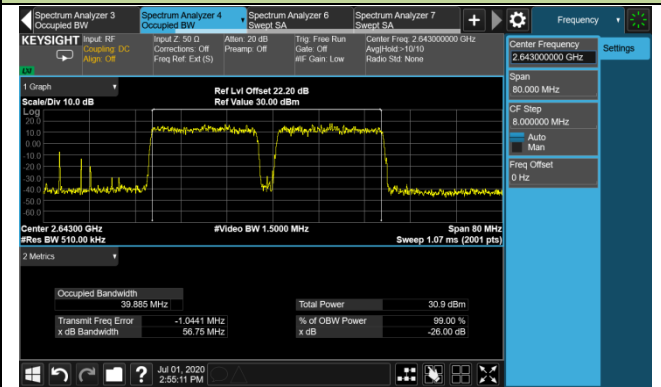

Top Channel

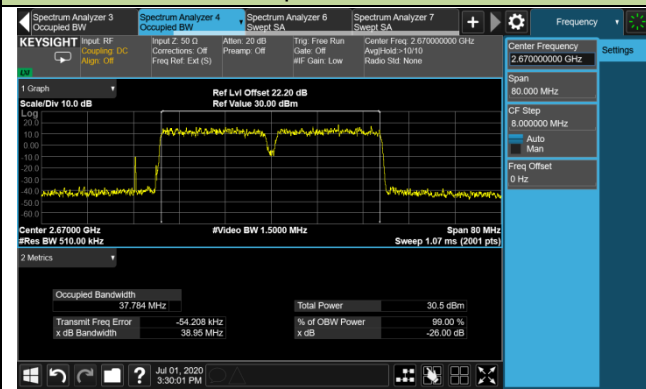

LTE Emission Bandwidth - 16QAM

Bottom Channel

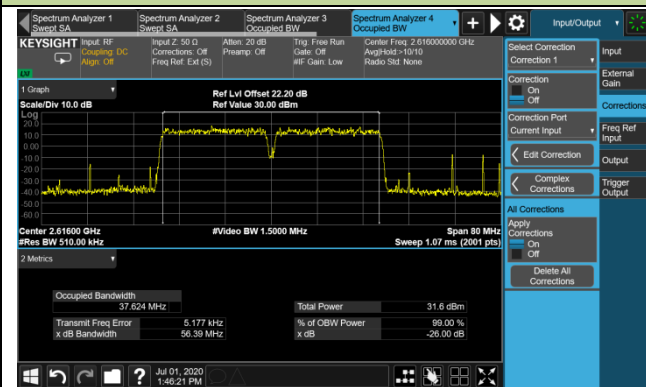

Middle Channel

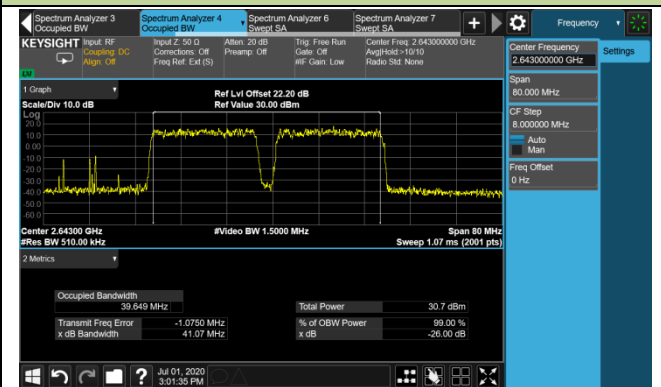

Top Channel

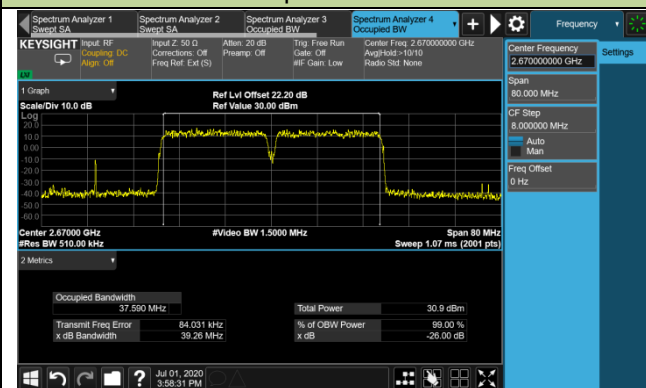

LTE Emission Bandwidth - 64QAM

Bottom Channel

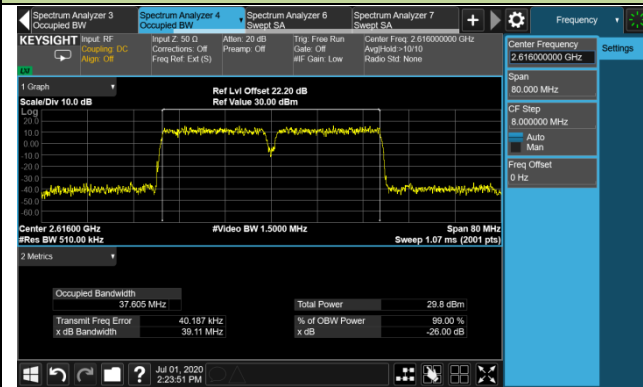

Middle Channel

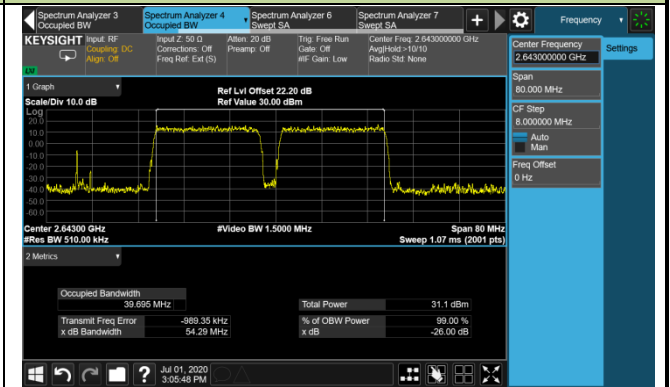

Top Channel

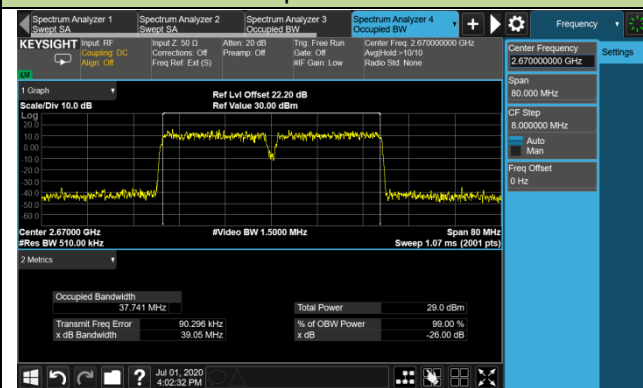

LTE Emission Bandwidth - 256QAM

Bottom Channel

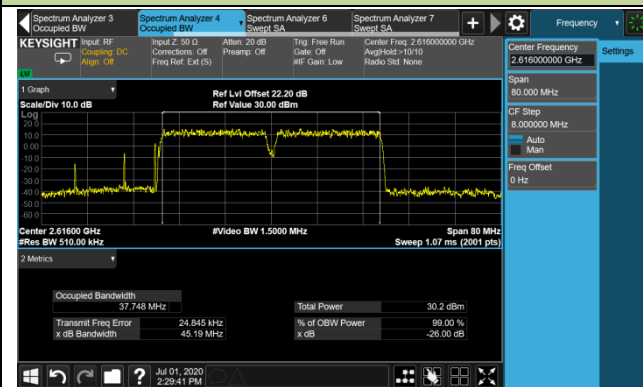

Middle Channel

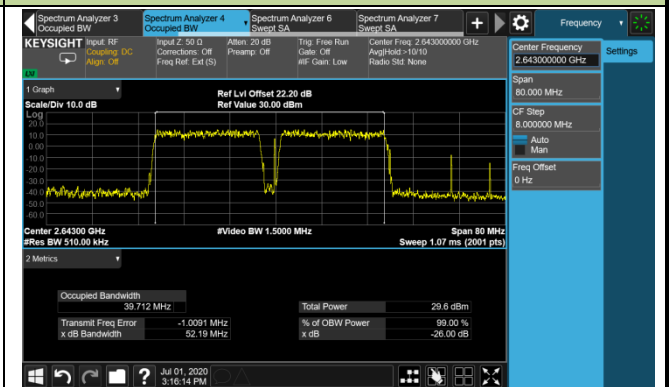

Top Channel

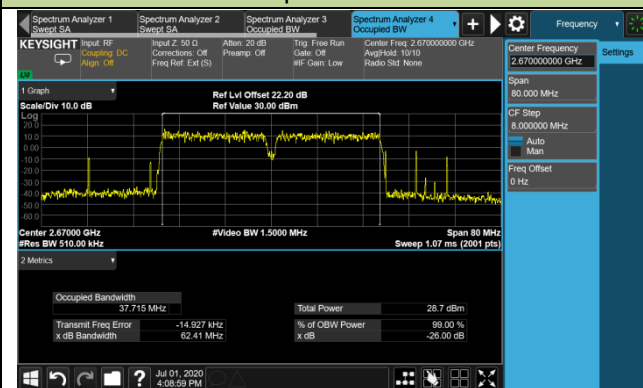

Product	AirScale Indoor Radio ASiR 5G-pRRH	Test Engineer	Kevin Ker
Test Site	SR2	Test Date	2020/07/01
Test Configuration	5G NR 100MHz + LTE 20 + 20 + 20MHz		
Test Channel	Bottom Channel: 5G NR 2546.01MHz, LTE 2606 + 2626 + 2646MHz Middle Channel: 5G NR 2563.02MHz, LTE 2623 + 2643 + 2663MHz Top Channel: 5G NR 2580MHz, LTE 2640 + 2660 + 2680MHz		

Modulation	Frequency (MHz)	Bandwidth (MHz)	26dB Bandwidth (MHz)		Total 26dB Bandwidth (MHz)	99% Bandwidth (MHz)		Total 99% Bandwidth (MHz)
			5G NR	LTE		5G NR	LTE	
Ant 0 / Ant 0+1 (5G NR) + Ant 3 / Ant 2+3 (LTE)								
QPSK	Bottom	100+60	100.4	65.95	166.35	96.70	57.62	154.32
	Middle	100+60	100.4	59.55	159.95	96.96	57.67	154.63
	Top	100+60	100.4	59.44	159.84	96.93	57.49	154.42
16QAM	Bottom	100+60	100.6	68.19	168.79	96.72	57.59	154.31
	Middle	100+60	100.4	71.04	171.44	96.82	57.43	154.25
	Top	100+60	100.4	59.64	160.04	97.01	57.44	154.45
64QAM	Bottom	100+60	100.5	64.53	165.03	96.99	57.52	154.51
	Middle	100+60	100.4	59.31	159.71	97.24	57.29	154.53
	Top	100+60	100.5	62.60	163.10	97.15	57.69	154.84
256QAM	Bottom	100+60	100.5	59.30	159.80	97.19	57.49	154.68
	Middle	100+60	100.4	60.13	160.53	97.39	57.72	155.11
	Top	100+60	100.5	67.49	167.99	97.43	57.57	155.00

5G NR Emission Bandwidth - QPSK

Bottom Channel

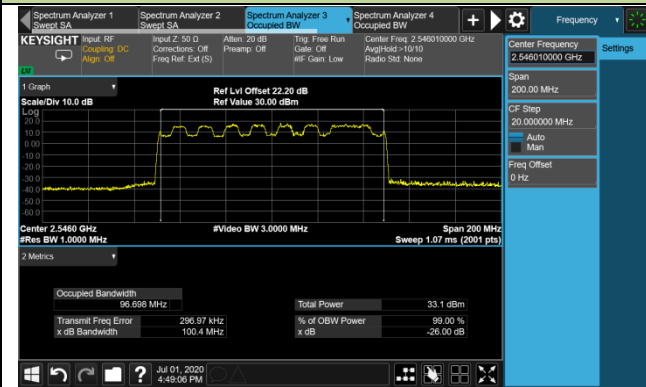

Middle Channel

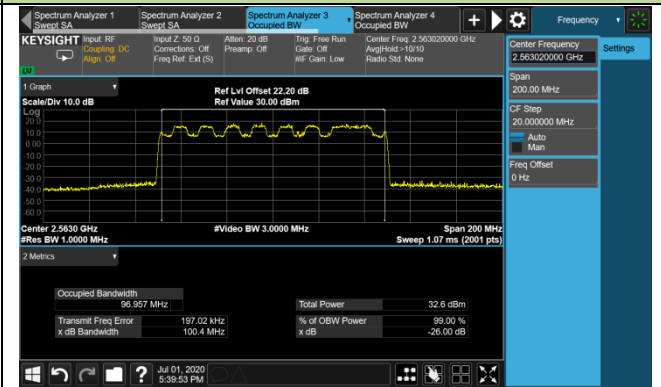

Top Channel

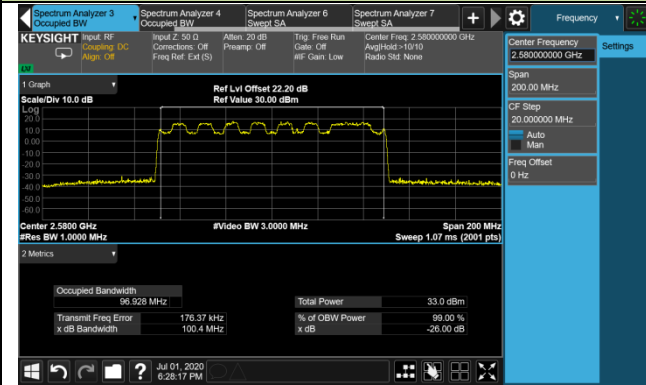

5G NR Emission Bandwidth - 16QAM

Bottom Channel

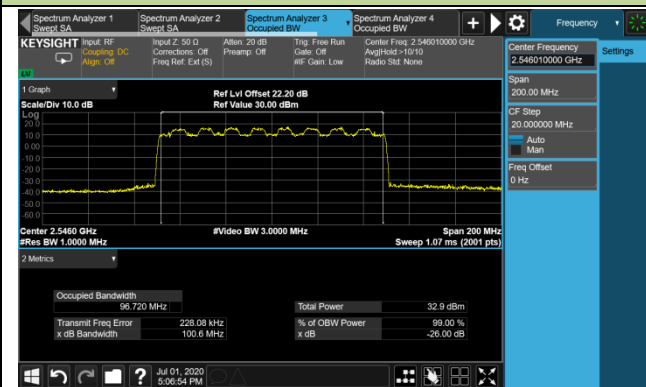

Middle Channel

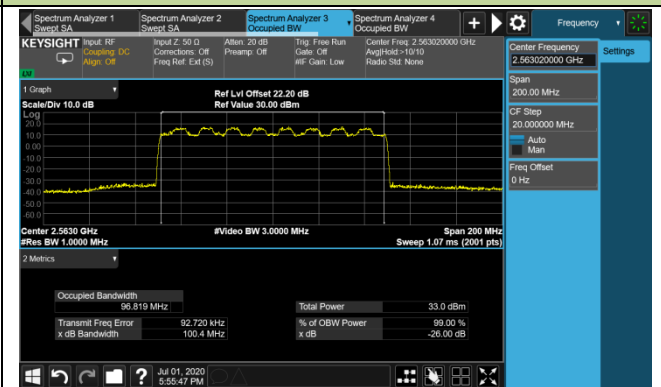

Top Channel

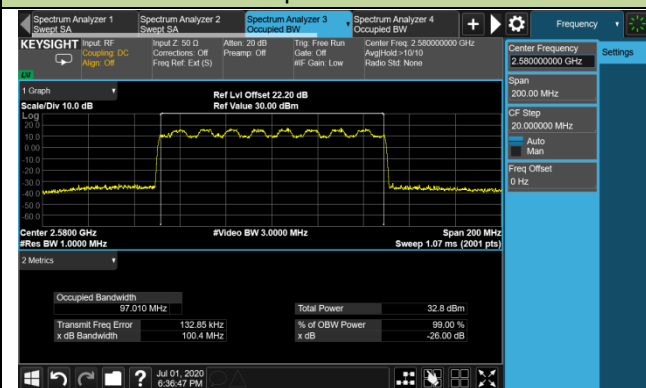

5G NR Emission Bandwidth - 64QAM

Bottom Channel

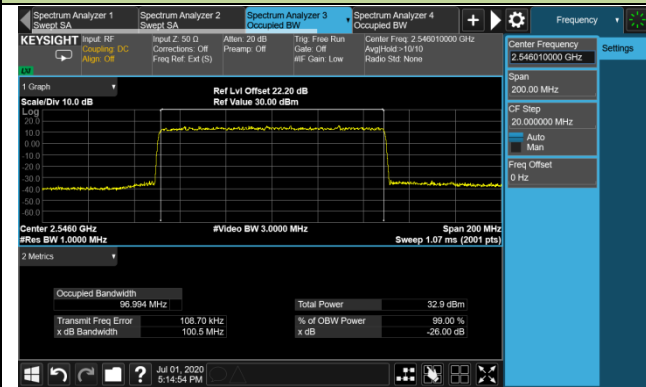

Middle Channel

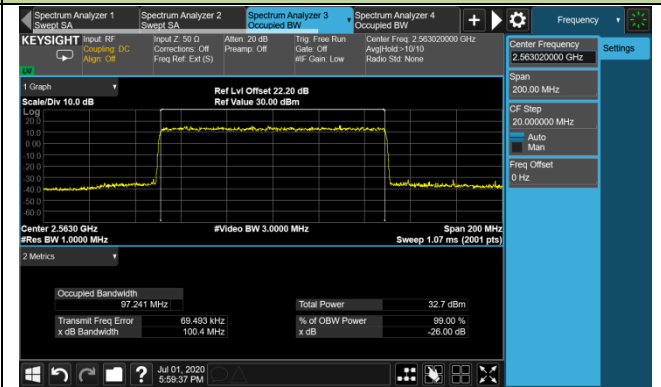

Top Channel

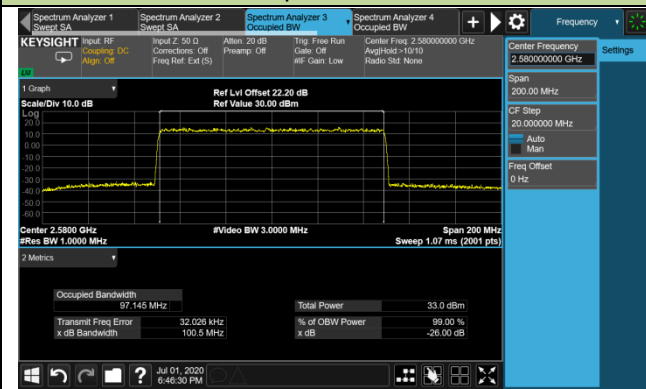

5G NR Emission Bandwidth - 256QAM

Bottom Channel

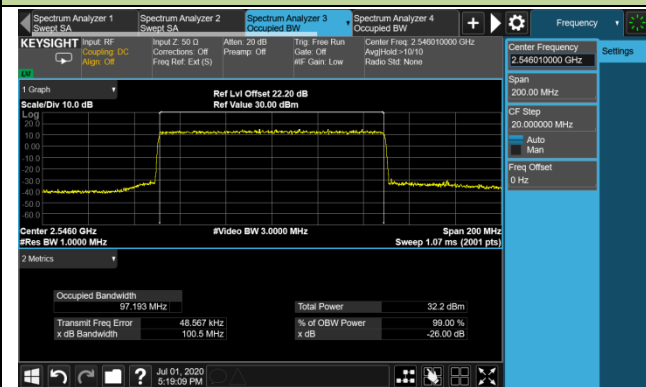

Middle Channel

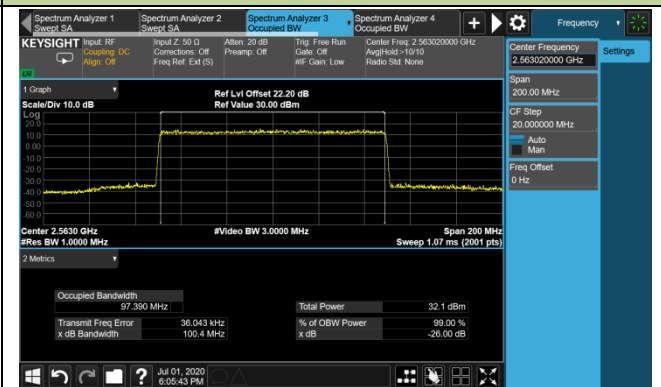

Top Channel

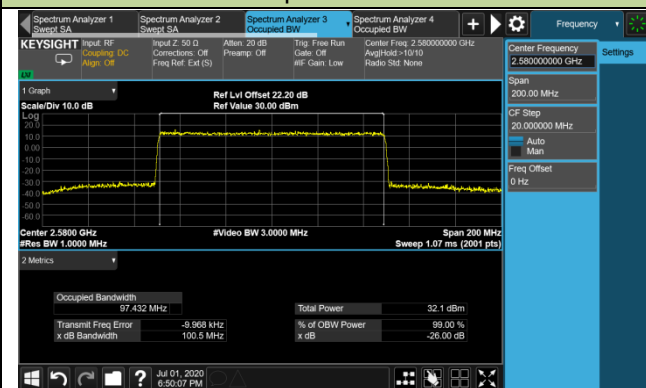

LTE Emission Bandwidth - QPSK

Bottom Channel

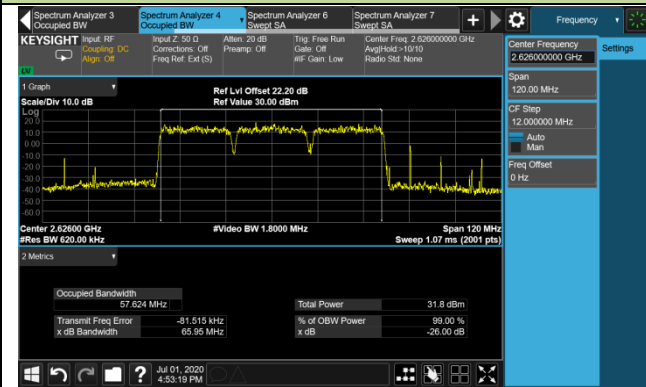

Middle Channel

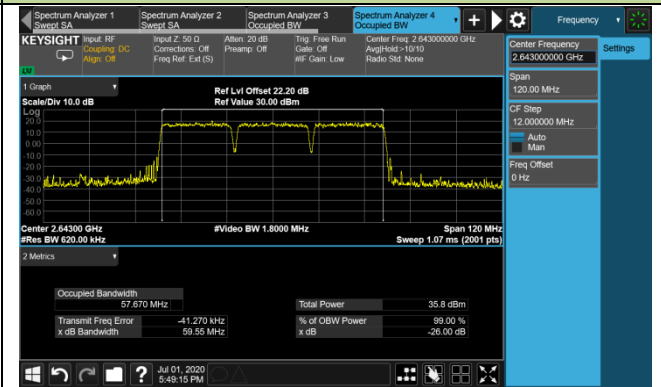

Top Channel

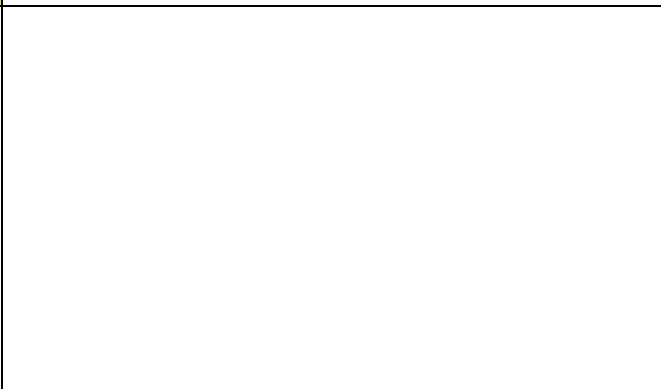
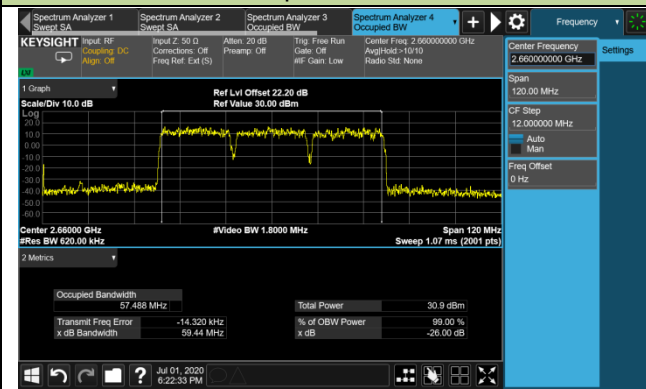

LTE Emission Bandwidth - 16QAM

Bottom Channel

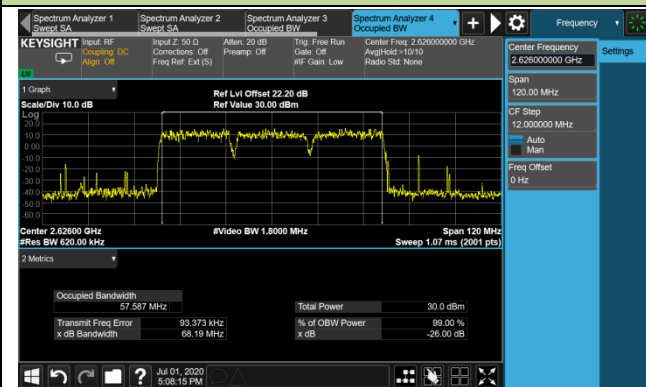

Middle Channel

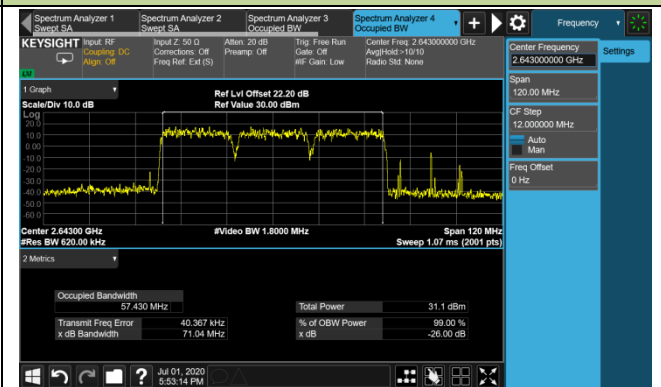

Top Channel

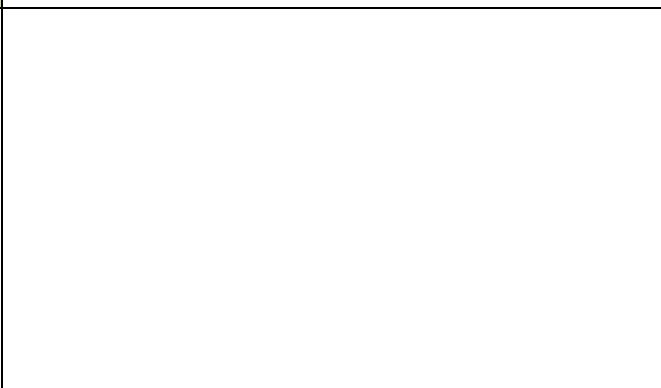
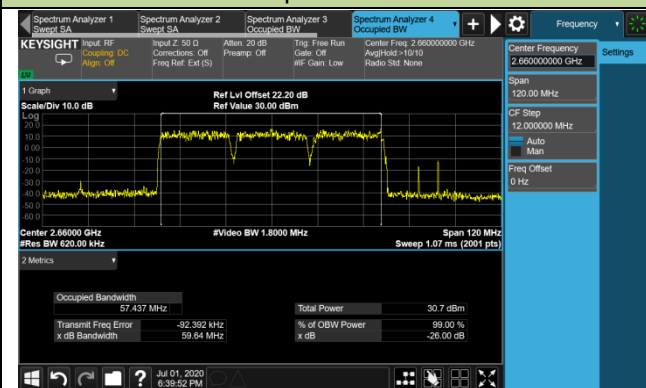

LTE Emission Bandwidth - 64QAM

Bottom Channel

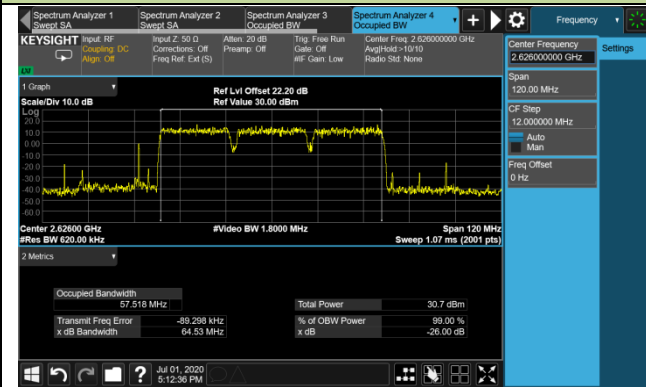

Middle Channel

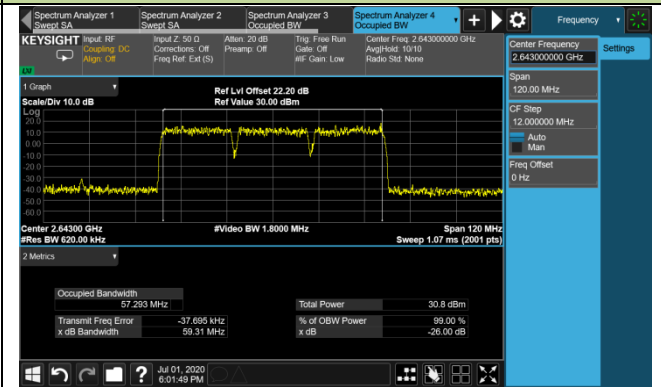

Top Channel

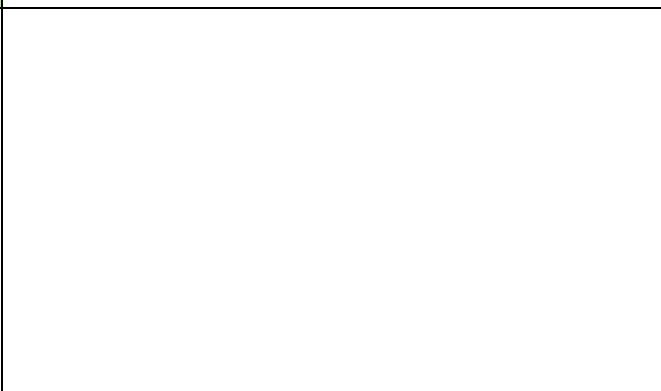
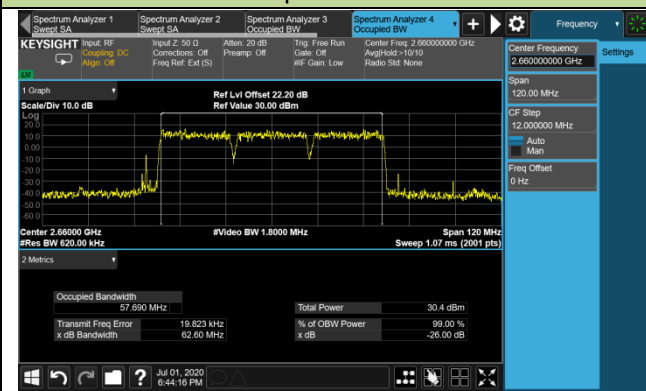

LTE Emission Bandwidth - 256QAM

Bottom Channel

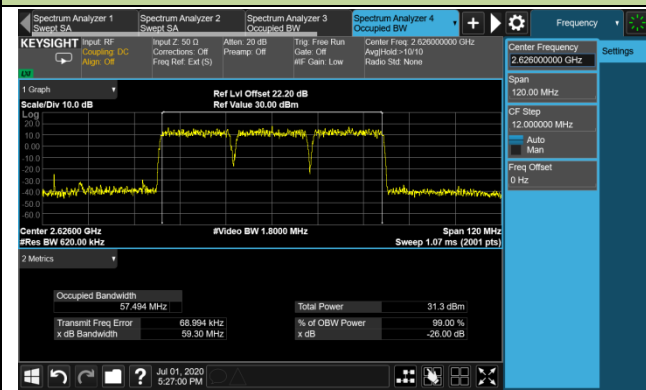

Middle Channel

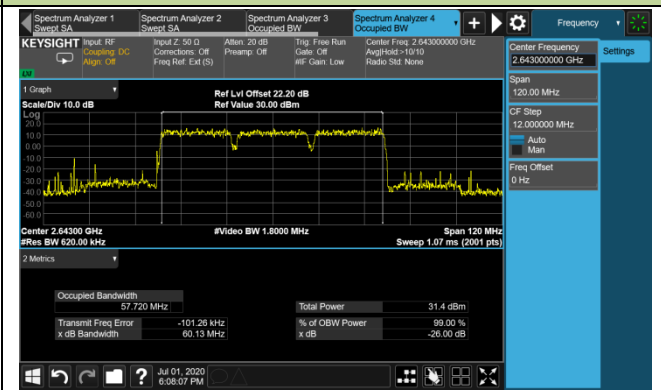

Top Channel

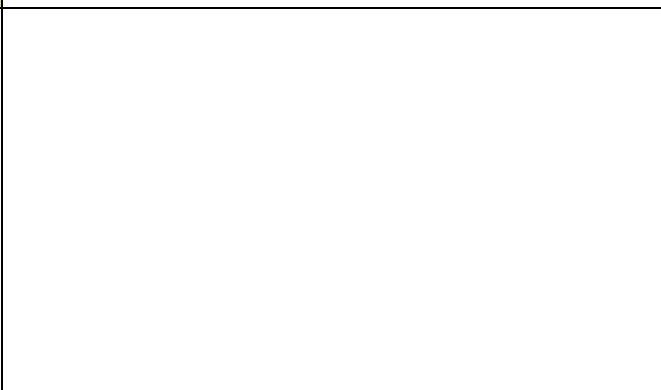
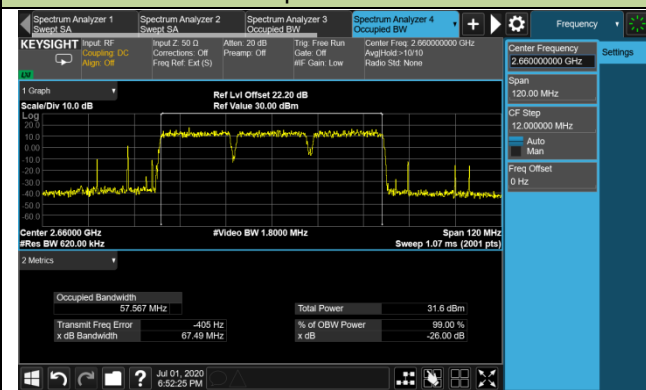

5.4. Frequency Stability Measurement

5.4.1. Test Limit

N/A

5.4.2. Test Procedures Used

KDB 971168 D01v03r01 - Section 9

ANSI C63.26-2015 - Section 5.6

5.4.3. Test Setting

Frequency Stability Under Temperature Variations:

The equipment under test was connected to an external AC or DC power supply and input rated voltage. RF output was connected to a frequency counter or spectrum analyzer via feed through attenuators. The EUT was placed inside the temperature chamber. Set the spectrum analyzer RBW low enough to obtain the desired frequency resolution and measure EUT 20°C operating frequency as reference frequency. Turn EUT off and set the chamber temperature to highest. After the temperature stabilized for approximately 30 minutes recorded the frequency. Repeat step measure with 10°C decreased per stage until the lowest temperature reached.

Frequency Stability Under Voltage Variations:

Set chamber temperature to 20°C. Use a variable AC power supply / DC power source to power the EUT and set the voltage to rated voltage. Set the spectrum analyzer RBW low enough to obtain the desired frequency resolution and recorded the frequency.

Reduce the input voltage to specify extreme voltage variation ($\pm 15\%$) and endpoint (If a product is specified to operate over a range of input voltage then the -15% variation is applied to the lowermost voltage and the $+15\%$ is applied to the uppermost voltage), record the maximum frequency change.

5.4.4. Test Setup

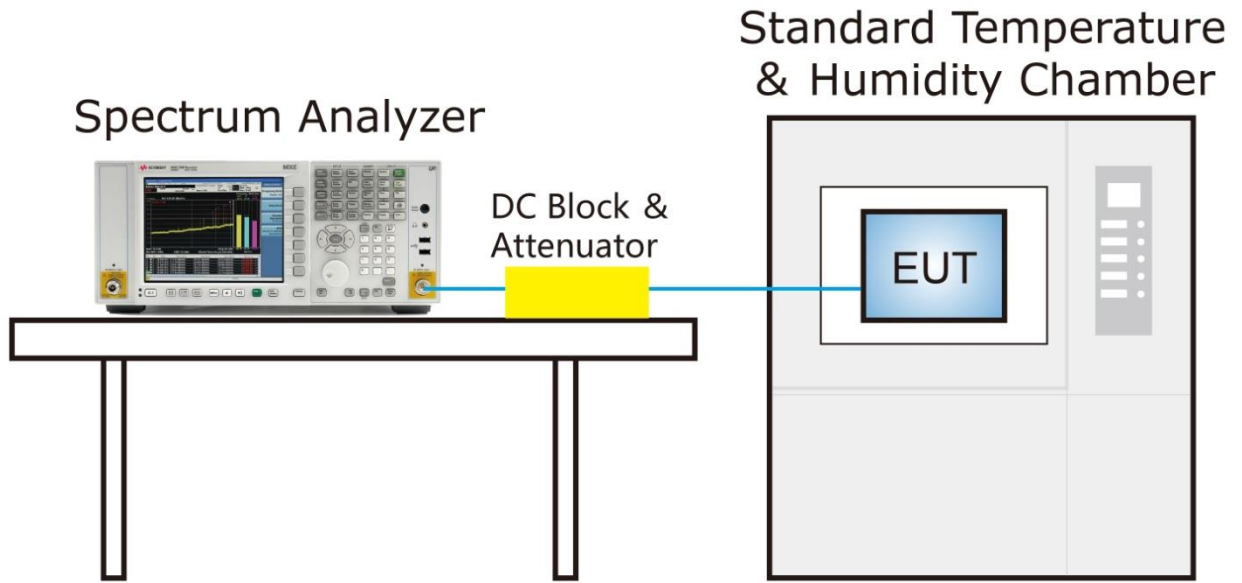

5.4.5. Test Result

Product	AirScale Indoor Radio ASiR 5G-pRRH	Test Engineer	Kevin Ker
Test Site	SR2	Test Date	2020/07/03
Test Configuration	5G NR 40MHz, 2592.99MHz		

Voltage (%)	Power (VDC)	Temp (°C)	Frequency Tolerance (ppm)
100%	54V	0	-0.1056
		+ 10	-0.1039
		+ 20 (Ref)	-0.1074
		+ 30	-0.1063
		+ 40	-0.1037
115%	57V	+ 20	-0.1045
85%	52V	+ 20	-0.1072

5.5. Band Edge Measurement

5.5.1. Test Limit

For all fixed digital user stations, the attenuation factor shall be not less than $43 + 10 \log (P)$ dB at the channel edge.

This device can be implement MIMO function, so the limit of spurious emissions needs to be reduced by $10 \cdot \log(\text{Numbers}_{\text{Ant}})$ according to FCC KDB 662911 D01 guidance.

The UUT can operate in either 2*2 MIMO mode. The 2*2 MIMO limit is applied in this test report and is adjusted to $-13 \text{ dBm} - 10 \cdot \log (2) = -16.01 \text{ dBm}$.

5.5.2. Test Procedure Used

KDB 971168 D01v03r01 - Section 6.1

ANSI C63.26-2015 - Section 5.7.1

5.5.3. Test Setting

1. Set the analyzer frequency to low or high channel.
1. RBW = The nominal RBW shall be in the range of 1% of the anticipated OBW;
2. VBW $\geq 3 \cdot$ RBW
3. Sweep time = auto
4. Detector = power averaging (rms)
5. Set sweep trigger to "free run."
6. Trace average at least 100 traces in power averaging (rms) mode if sweep is set to auto-couple.

To accurately determine the average power over the on and off time of the transmitter, it can be necessary to increase the number of traces to be averaged above 100, or if using a manually configured sweep time, increase the sweep time.

5.5.4. Test Setup

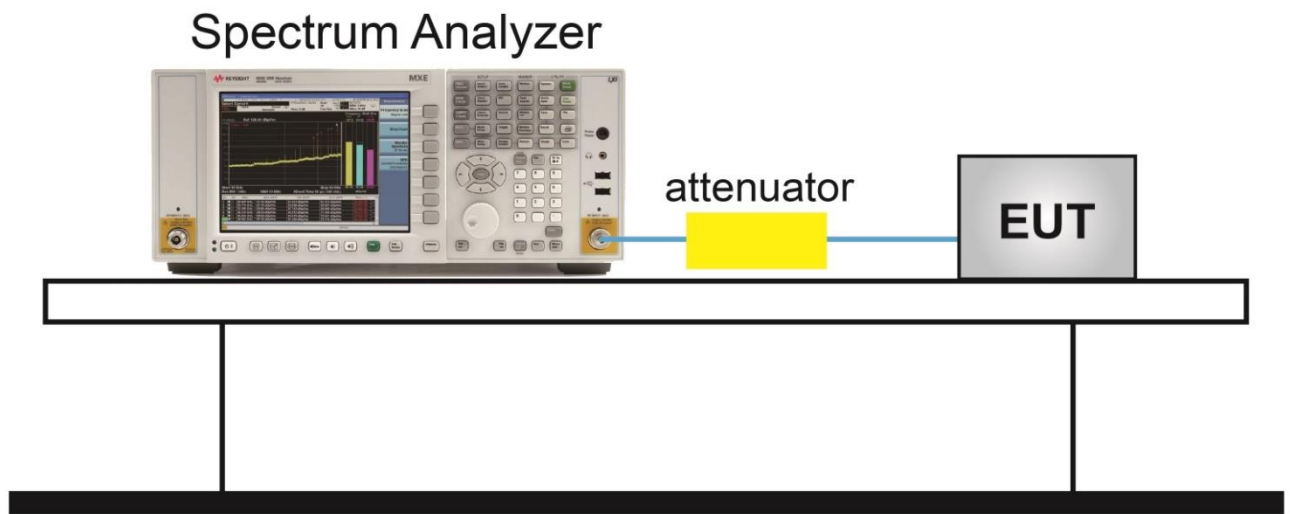

5.5.5. Test Result

Product	AirScale Indoor Radio ASiR 5G-pRRH	Test Engineer	Kevin Ker
Test Site	SR2	Test Date	2020/07/03
Test Configuration	LTE 20MHz + 5G NR 40MHz		
Test Channel	Bottom Channel: LTE 2506MHz, 5G NR 2535.99MHz Middle Channel: LTE 2573MHz, 5G NR 2602.98MHz Top Channel: LTE 2640MHz, 5G NR 2670MHz		

Frequency (MHz)	Channel Bandwidth (MHz)	Max Band Edge (dBm)				Limit (dBm)	Result
		Ant 0	Ant 1	Ant 2	Ant 3		
QPSK							
Bottom	20	-	-	-46.08	-45.79	≤ -16.01	Pass
Top	40	-42.34	-42.49	-	-	≤ -16.01	Pass

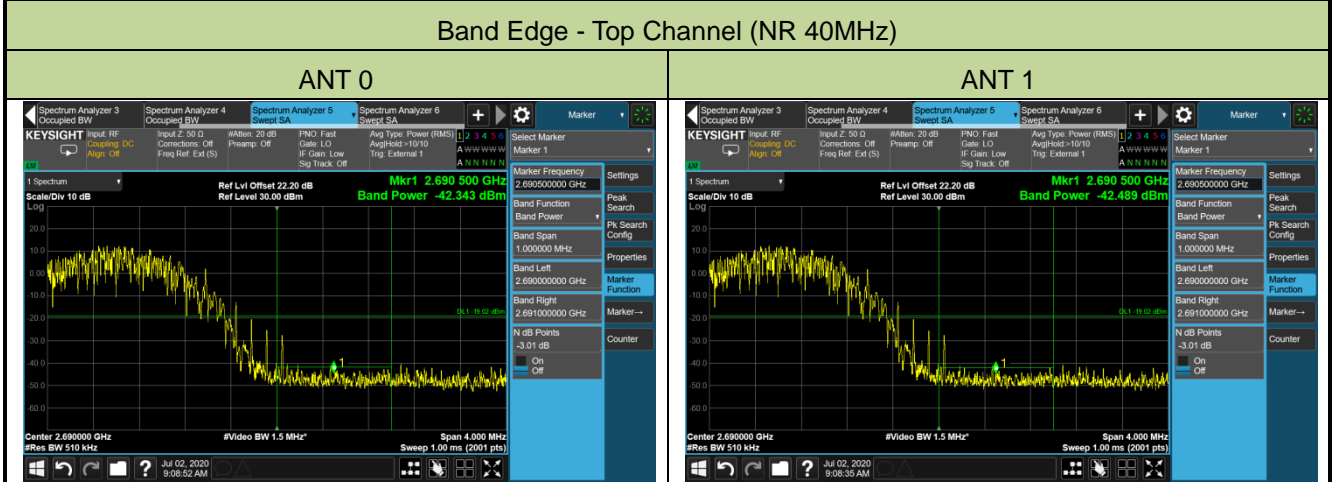
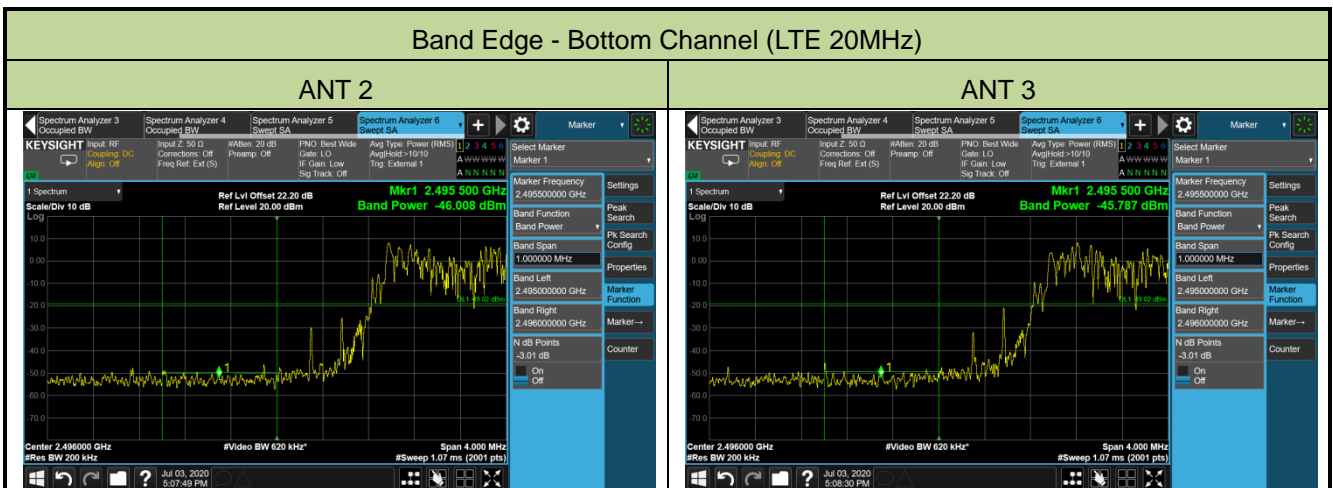

Product	AirScale Indoor Radio ASiR 5G-pRRH	Test Engineer	Kevin Ker
Test Site	SR2	Test Date	2020/07/03
Test Configuration	LTE 20MHz + 5G NR 60MHz		
Test Channel	Bottom Channel: LTE 2506MHz, 5G NR 2545.98MHz Middle Channel: LTE 2563MHz, 5G NR 2602.98MHz Top Channel: LTE 2620MHz, 5G NR 2659.98MHz		

Frequency (MHz)	Channel Bandwidth (MHz)	Max Band Edge (dBm)				Limit (dBm)	Result
		Ant 0	Ant 1	Ant 2	Ant 3		
QPSK							
Bottom	20	-	-	-45.57	-45.79	≤ -16.01	Pass
Top	60	-46.06	-46.02	-	-	≤ -16.01	Pass

Band Edge - Bottom Channel (LTE 20MHz)

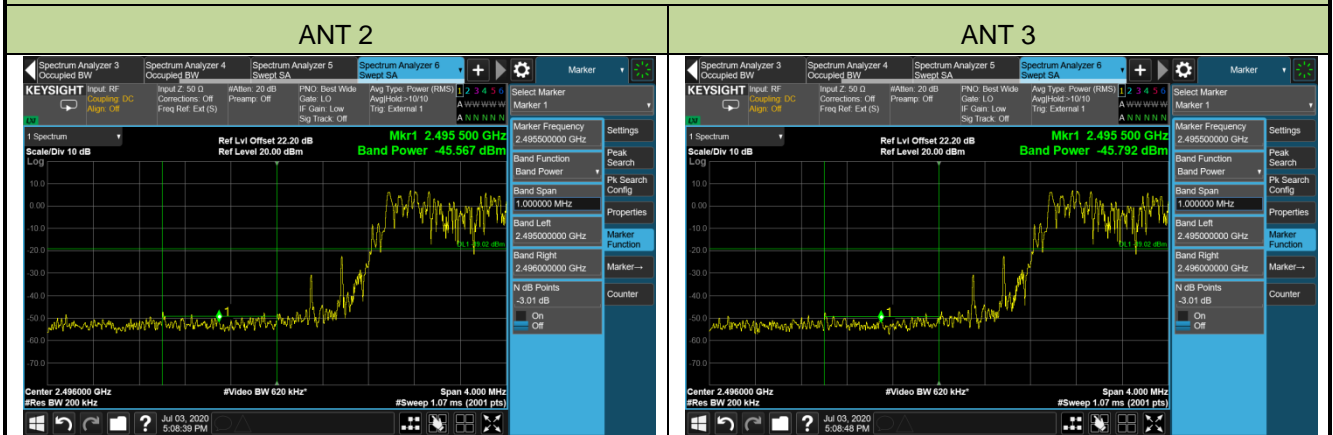

Band Edge - Top Channel (NR 60MHz)

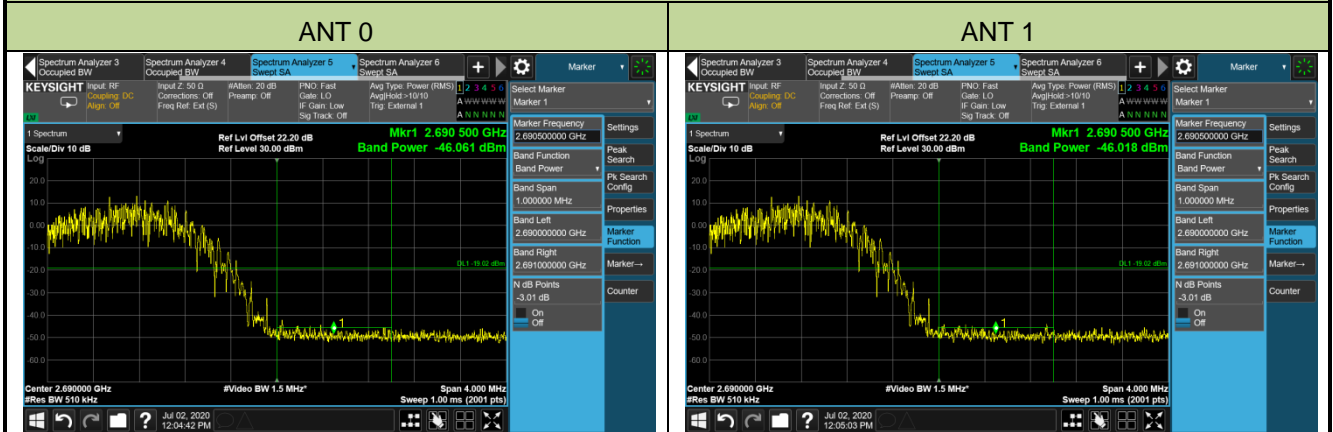

Product	AirScale Indoor Radio ASiR 5G-pRRH	Test Engineer	Kevin Ker
Test Site	SR2	Test Date	2020/07/02
Test Configuration	LTE 20MHz + 5G NR 100MHz		
Test Channel	Bottom Channel: LTE 2506MHz, 5G NR 2565.99MHz Middle Channel: LTE 2543MHz, 5G NR 2602.98MHz Top Channel: LTE 2580MHz, 5G NR 2640MHz		

Frequency (MHz)	Channel Bandwidth (MHz)	Max Band Edge (dBm)				Limit (dBm)	Result
		Ant 0	Ant 1	Ant 2	Ant 3		
QPSK							
Bottom	20	-	-	-45.76	-45.62	≤ -16.01	Pass
Top	100	-25.76	-25.61	-	-	≤ -16.01	Pass

